

| | | | |
|------|-----------------------------------|---|-------------------|
| [19] | INTELLECTUAL PROPERTY PHILIPPINES | | |
| [12] | INVENTION PUBLICATION | | |
| [11] | Publication Number: | 12014501432 | Document Code: B1 |
| [22] | Publication Date: | 22/9/2014 | |
| [21] | Application Number: | 12014501432 | Document Code: A |
| [22] | Date Filed: | 20/6/2014 | |
| [54] | Title: | DEVELOPING DEVICE, CARTRIDGE AND ELECTROPHOTOGRAPHIC IMAGE FORMING APPARATUS | |
| [71] | Applicant(s): | CANON KK | |
| [72] | Inventor(s): | MATSUSHITA MASAOKI MATSUNAGA TOMONORI MIZUKOSHI SHUNSUKE MATSUDA KOHEI MIURA JUN KANAZAWA TAKAYUKI MUKAI TAKASHI | |
| [30] | Priority Data: | 14/11/2012 JP20120249882 | |
| [51] | International Class 8: | G03G 15/08 20060101AFI20171127BHPH; | |
| [57] | Abstract: | <p>A developing device includes: a flexible container, provide with an opening, for accommodating the developer; a frame for accommodating the container; an urging member, rotatably provided inside the frame, for urging the container by rotation thereof to deform the container; and a developer carrying member for carrying the developer on its surface to feed the developer. A distance X from a rotation center of the urging member to the surface of the developer carrying member and a length T from the rotation center of the urging member to a free end thereof for urging the container satisfy a relationship of $X \geq T$. A shielding member for preventing contact of the urging member with the developer carrying member is provided between the rotation center of the urging member and the surface of the developer carrying member or in a neighborhood thereof.</p> | |

2017 MAY 12 PM 4:12

06/09/2018 09:58 04589

DESCRIPTION

[TITLE OF INVENTION]

**DEVELOPING DEVICE, CARTRIDGE AND ELECTROPHOTOGRAPHIC
5 IMAGE FORMING APPARATUS**

[TECHNICAL FIELD]

[0001] The present invention relates to a developing
device for carrying a developer, accommodated in a
10 developer accommodating container to feed the
developer, a detachably mountable cartridge including
the developing device, and an electrophotographic
image forming apparatus including the cartridge.

[0002] The electrophotographic image forming
15 apparatus forms an image on a recording material
(medium) by using, e.g., an electrophotographic image
forming process and may include, e.g., an
electrophotographic copying machine, an
electrophotographic printer (such as an LED printer or
20 a laser beam printer), an electrophotographic
facsimile machine, and the like.

[0003] Further, the cartridge refers to a cartridge,
including at least the developing device, detachably
mountable to a main assembly of the image forming
25 apparatus and refers to a cartridge, prepared by
integrally assembling the developing device and at
least an electrophotographic photosensitive member,

detachably mountable to the main assembly of the image forming apparatus.

[0004] Further, the developing device is accommodated in the image forming apparatus or the cartridge.

5

[BACKGROUND ART]

[0005] In a conventional electrophotographic image forming apparatus using the electrophotographic image forming process, a process cartridge type in which an
10 electrophotographic photosensitive member and process means acting on the photosensitive member are integrally assembled into a cartridge and this cartridge is detachably mountable to a main assembly of the electrophotographic image forming apparatus is
15 employed.

[0006] In such a process cartridge, as shown in (b) of Figure 34, an opening provided to a developer accommodating frame 34 for accommodating a developer (toner, carrier, etc.) is sealed with a sealing member.
20 Further, as an example of a sealing means, there is a type in which a sheet-like sealing member 32 as shown in (a) of Figure 34 is welded by heat seal or the like at a periphery of the opening of the developer accommodating frame 31. In order to reduce a load of a
25 user when a welded portion 33 formed by the welding, a constitution in which a free end of the sealing member 32 is folded back and is capable of being pulled off

in a side (in an arrow direction in (a) of Figure 34) opposite from a side where the folded portion is located has been widely used (Japanese Laid-Open Patent Application (JP-A) Hei 04-66980, Figure 13).

5 [0007] In an actual form of the process cartridge, as shown in (b) of Figure 34, the opening is sealed with a toner seal 32. After the opening is unsealed or in the case where there is no toner seal, a rotation shaft 40 is rotated to feed the developer to the
10 neighborhood of a developer carrying member 13 by a developer feeding member 41.

[0008] Further, a constitution in which a developer accommodating unit separable from and mountable to a main assembly of the process cartridge is provided and
15 in which the sheet member or the like is pulled off to feed the developer has been proposed as follows.

According to JP-A Hei 04-166963, the user pulls an end of bag-like sheet film accommodating the developer to unseal the bag, so that the developer can be supplied.
20 According to Japanese Utility-Model Application (JP-U) Hei 01-128351, a sheet blocking an opening for permitting discharge of a developer is wound up by a rotatable member, so that supply of the developer is automatically started. JP-A 2008-134483 principally
25 aims at preventing agglomeration of the developer, and a stirring sheet blocks an opening of a hopper portion accommodating the developer and functions as a

stirring means after the opening is unsealed.

[0009] Further, in order to solve a problem such that the developer is scattered in the process cartridge in a developer filling step during manufacturing of the process cartridge, a constitution in which a
5 deformable inner container is used has been proposed (JP-A Hei 04-66980, Figure 1).

[0010] However, in the conventional constitutions described above was accompanied with the following
10 problems.

[0011] In the constitution in which the container for applying the developer and the stirring member are provided in the developer accommodating unit, an upsizing is unavoidable. Therefore, in the case where
15 the above-described conventional constitution is used for the developer accommodating portion of the detachably mountable process cartridge, the process cartridge is upsized, so that the image forming apparatus in which the process cartridge is mounted is
20 also upsized.

[0012] Therefore, in order to downsize such a process cartridge, it would be considered that, e.g., as shown in (a) and (b) of Figure 35, a distance between a developing roller 13 and a rotation shaft 40 of a
25 developer feeding member 41 is shortened. However, in this case, irrespective of presence and absence of a toner seal 32, the developer feeding member 41 and the

developing roller 13 contact each other, so that there was a possibility of generation of an image defect on an output image.

5 [SUMMARY OF INVENTION]

[0013] A principal object of the present invention is to provide a developing device capable of downsizing a process cartridge while preventing contact between a developer feeding member and a developing roller.

10 [0014] According to an aspect of the present invention, there is provided a developing device comprising: a flexible container, including an opening for permitting discharge of a developer, for accommodating the developer; a frame for accommodating
15 the flexible container and for accommodating the developer discharged from the flexible container; an urging member, rotatably provided inside the frame, for urging the flexible container by rotation thereof to deform the flexible container; and a developer
20 carrying member for carrying the developer on its surface to feed the developer, wherein a distance X from a rotation center of the urging member to the surface of the developer carrying member and a length T from the rotation center of the urging member to a
25 free end thereof for urging the flexible container satisfy a relationship of $X < T$, and wherein a shielding member for preventing contact of the urging

06/09/2018 09:58 04593

member with the developer carrying member is provided between the rotation center of the urging member and the surface of the developer carrying member or in a neighborhood thereof.

5 [0015] These and other objects, features and advantages of the present invention will become more apparent upon a consideration of the following description of the preferred embodiments of the present invention taken in conjunction with the
10 accompanying drawings.

[BRIEF DESCRIPTION OF DRAWINGS]

[0016] Figure 1 is a principal sectional view of a process cartridge in an embodiment of the present
15 invention.

[0017] Figure 2 is a principal sectional view of an image forming apparatus in the embodiment of the present invention.

[0018] Figure 3 is a perspective view from a cross
20 section of a developer accommodating container including a sealing member in the embodiment of the present invention.

[0019] Figure 4 is a sectional view of a developer accommodating unit before unsealing in the embodiment
25 of the present invention.

[0020] Figure 5 is a sectional view of the developer accommodating unit immediately before the unsealing in

the embodiment of the present invention.

[0021] Figure 6 is a sectional view of the developer accommodating unit in which a discharging portion is unsealed in midstream in the embodiment of the present invention.

[0022] Parts (a), (b) and (c) of Figure 7, and (a) and (b) of Figure 8 are sectional views for illustrating a process of unsealing the discharging portion in the embodiment of the present invention.

[0023] Figure 9 is a sectional view of the developer accommodating unit after the unsealing in the embodiment of the present invention.

[0024] Figure 10 is an illustration of the developer accommodating container before unsealing in the embodiment of the present invention.

[0025] Figure 11 is an illustration of the developer accommodating container in which the discharging portion is unsealed in midstream in the embodiment of the present invention.

[0026] Figure 12 is a sectional view for illustrating the discharging portion in the embodiment of the present invention.

[0027] Parts (a) and (b) of Figure 13, (a) to (c) of Figure 14, and Figure 15 are illustrates of a developer accommodating unit in which it is difficult to unseal a discharging portion in an embodiment which is not in accordance with the present invention.

[0028] Parts (a) to (d) of Figure 16 and Figure 17 are sectional views of the developer accommodating unit in the embodiment of the present invention.

[0029] Figure 18 is a perspective view of a developer accommodating container in Fourth Embodiment of the present invention.

[0030] Figure 19 is a sectional view of a developer accommodating unit in Fourth Embodiment of the present invention.

10 [0031] Figure 20, and (a) and (b) of Figure 21 are illustrations of the developer accommodating container in the embodiment of the present invention.

[0032] Parts (a) and (b) of Figure 22 are illustrations of a developer accommodating container in an embodiment which is not in accordance with the present invention.

[0033] Parts (a) and (b) of Figure 23, and (a) and (b) of Figure 24 are illustrations of the developer accommodating unit in the embodiment of the present invention.

[0034] Figure 25 and (a) to (c) of Figure 26 are illustrations of the developer accommodating unit in the embodiment of the present invention.

[0035] Parts (a) to (d) of Figure 27 are illustrations of a fixing portion of the developer accommodating container in the embodiment of the present invention.

[0036] Parts (a) to (d) of Figure 28 are illustrations of an opening of the developer accommodating container in the embodiment of the present invention.

5 [0037] Parts (a) to (c) of Figure 29 and (a) to (c) of Figure 30 are illustrations of developer accommodating containers in embodiments of the present invention.

[0038] Parts (a) and (b) of Figure 31 are
10 illustrations of the developer accommodating container provided with an unsealing member.

[0039] Parts (a) and (b) of Figure 32, and (a) and (b) of Figure 33 are illustrations of the developer accommodating unit in the embodiment of the present
15 invention.

[0040] Parts (a) and (b) of Figure 34 are illustrations of a conventional process cartridge.

[0041] Parts (a) to (e) of Figure 35 are sectional views of a developer accommodating unit in Fifth
20 Embodiment of the present invention.

[0042] Parts (a) to (c) of Figure 36 are illustrations of an effect of a shielding member in the embodiment of the present invention.

[0043] Parts (a) and (b) of Figure 37, and (a) to (d)
25 of Figure 38 are illustrations of a constitution of the shielding member in the embodiment of the present invention.

[0044] Parts (a) and (b) of Figure 39 are illustration of a developer accommodating unit in Third Embodiment of the present invention.

[0045] Figure 40 is a principal sectional view of a process cartridge in the case where a seal also functions as an urging member.

[0046] Figure 41 is an illustration of openings of a developer accommodating container in Sixth Embodiment of the present invention.

10 [0047] Figures 42 and 43 are illustrations of diffusing members in Sixth Embodiment of the present invention.

[0048] Figures 44 and 45 are illustrations of a developer accommodating unit in Sixth Embodiment of the present invention.

[0049] Figure 46 is a sectional view of the diffusing members in Sixth Embodiment of the present invention.

[0050] Figures 47, 48, and (a) and (b) of each of Figures 49 to 52 are illustrations of the diffusing members in Sixth Embodiment of the present invention.

[0051] Figures 53 and 54 are illustrations of developer accommodating units in Seventh Embodiment of the present invention.

[0052] Figures 55 to 58 are illustrations of developer accommodating units in Eighth Embodiment of the present invention.

[DESCRIPTION OF EMBODIMENTS]

[0053] Hereinbelow, preferred embodiments of the present invention will be exemplarily and specifically described with reference to the drawings. However, 5 dimensions, materials, shapes, relative arrangements and the like of constituent elements described in the following embodiments are appropriately changed depending on constitutions or various conditions of devices (apparatuses) to which the present invention 10 is applied. Therefore, the scope of the present invention is not limited thereto unless otherwise specified.

[0054] In the following description, a developer accommodating container refers to at least a 15 flexibility container and a sealing member for sealing an opening, provided to the sealing member, for permitting discharge of a developer. The developer accommodating container before the developer is accommodated therein is referred to as a developer 20 accommodating container 37 for accommodating the developer. The developer accommodating container which accommodates the developer and which is provided with an unsealing member for removing (unsealing) the sealing member is referred to as a developer 25 accommodating container 30 including the unsealing member. The developer accommodating container which accommodates the developer and which is not provided

with the sealing member is referred to as a developer accommodating container 26 accommodating the developer.

[0055] Incidentally, for simplification, these developer accommodating containers will be described
5 as the developer accommodating container 37, the developer accommodating container 30 and the developer accommodating container 26 by using different reference numerals.

[0056] A developer accommodating unit includes at
10 least the developer accommodating container and a frame for accommodating the developer accommodating container.

(First Embodiment)

[0057] Figure 1 is a principal sectional view of a
15 process cartridge including the developer accommodating unit to which the present invention is applicable, and Figure 2 is a principal sectional view of an electrophotographic image forming apparatus to which the present invention is applicable.

20 <General structure of process cartridge>

[0058] The process cartridge includes an image bearing member (electrophotographic photosensitive member) and process means acting on the image bearing member. Examples of the process means include a
25 charging means for electrically charging a surface of the image bearing member, a developing device for forming an image on the image bearing member, and a

cleaning means for removing a developer (toner, carrier, etc.) remaining on the image bearing member surface.

[0059] The process cartridge A in this embodiment includes, as shown in Figure 1, includes a photosensitive drum 11 as the image bearing member and includes, at a periphery of the photosensitive drum 11, a charging roller 12 as the charging means and a cleaner unit 24 including an elastic cleaning blade 14 as the cleaning means. Further, the process cartridge A includes a developing device 38 including a first frame 17 and a second frame 18. The process cartridge A is prepared by integrally assembling the cleaner unit 24 and the developing device 38, and is constituted so as to be detachably mountable to an image forming apparatus main assembly B as shown in Figure 2. A developing device 38 includes a developing roller 13 as the developing means, a developing blade 15, a developer supplying roller 23, and a developer accommodating container 26 in which the developer is accommodated. The developing roller 13 and the developing blade are supported by the first frame 17.

<General structure of electrophotographic image forming apparatus>

[0060] The process cartridge A is as shown in Figure 2, mounted in the image forming apparatus main assembly B and is used for image formation. In the

image formation, a sheet S is fed by a feeding roller 7 from a sheet cassette 6 mounted at a lower portion of the apparatus and in synchronism with this sheet feeding, the photosensitive drum 11 is selectively exposed to light by an exposure device 8 to form a latent image. The developer is supplied to the developing roller 13 (developer carrying member) by the developer supplying roller 23 having a sponge shape and is carried in a thin layer on the surface of the developing roller 13. By applying a developing bias to the developing roller 13, the developer is supplied depending on the latent image and thus the latent image is developed into a developer image. This developer image is transferred onto the fed sheet S under bias voltage application to a transfer roller 9. The sheet S is conveyed to a fixing device 10, in which the image is fixed on the sheet S and then the sheet S is discharged to a discharge portion 3 at an upper portion of the apparatus.

<Structure of developer accommodating unit>

[0061] Next, a structure of a developer accommodating unit 25 will be described with reference to Figures 3, 4, (a) of Figure 7 and Figure 20. Figure 3 is a perspective view of the developer accommodating container 30, as seen from a cross-sectional side, Figure 7 is a detailed sectional view in the neighborhood of the discharging portion 35 for

permitting discharge of the developer from a developer bag 16 as a flexible container, and Figure 20 is a sectional view of the developer accommodating container 26 as seen from a cross-sectional side.

5 Incidentally, the sectional views are illustrated along a plane passing through an unsealing member 20, an opening 35a and fixing portions 16d and 16e.

Further, the sectional views are illustrated along a plane perpendicular to a rotation shaft of the

10 unsealing member 20.

(Developer accommodating unit)

[0062] The developer accommodating unit 25 is, as shown in Figure 4, constituted by the developer accommodating container 30, the developing roller 13, 15 the developing blade 15, the developer supplying roller 23, and the first and second frames 17 and 18 for supporting these members. A combination of the first and second frames is a frame in which the developer accommodating container 30 is accommodated.

20 [0063] In this embodiment, the developer accommodating unit 25 is the same as the developing device 38. This is because the developer accommodating unit 25 includes the developing roller 13, the developing blade 15 and the developer supplying roller 23. However, the developing roller 13, the developing blade 15 and the developer supplying roller 23 may 25 also be supported by a frame separately from the

developer accommodating unit 25 and thus may be separated from the developer accommodating unit 25. In this case, the developing device 38 is constituted by the developer accommodating unit 25, the developing roller 13, the developing blade 15 and the developer supplying roller 23 (not shown).

[0064] In this embodiment, the developing roller 13 and the developer supplying roller 23 are used as a developer carrying member, and a constitution including the developing roller 13 and the developer supplying roller 23 is exemplified as the developer carrying member. The developing roller 13 is a developer carrying member (portion) for carrying the developer on its surface and for feeding the developer to a developing portion where it opposes the photosensitive drum 11. The developer supplying roller 23 is a developer carrying member (portion) for removing, from the developing roller 13, the developer remaining on the developing roller 13 after the development at the developing portion and for supplying (feeding) a fresh developer to the developing roller 13. The constitution of the developer carrying member is not limited to the above constitution but may also be a constitution including only, e.g., the developing roller 13 as the developer carrying member.

(Developer accommodating container including unsealing

member)

[0065] The developer accommodating container 30 including the unsealing member is constituted by an unsealing member 20 and the developer accommodating
5 container 26 as shown in Figures 3 and 4.

[0066] The unsealing member 20 includes an engaging portion 20b to be engaged with a sealing member 19, and by engaging a portion-to-be-engaged 19b of the developer accommodating container 26 with the engaging
10 portion 20b, the developer accommodating container 30 including the unsealing member 20 is constituted.

(Developer accommodating container in which developer is accommodated)

[0067] As shown in (c) of Figure 30, the developer
15 accommodating container 26 is constituted by a developer, a developer bag 16 and the sealing member 19. The developer is powder.

[0068] The developer bag 16 of the developer accommodating container 26 is sealed with the sealing
20 member 19 at the plurality of openings 35a for permitting the discharge of the developer and includes a connecting (bonding) portion which seals a filling opening for permitting the filling of the developer. Thus, the respective openings 35a and the filling
25 opening 39 of the developer accommodating container 26 in which the developer is accommodated are sealed and therefore the accommodated developer is not leaked out

to the outside, so that the developer accommodating
container 26 can be treated at a single unit. Further,
the sealing member 19 includes a hole as the
portion-to-be-engaged 19b to be engaged with the
5 unsealing member 20, thus being engageable with the
unsealing member 20.

(Developer accommodating container for accommodating
developer)

[0069] As shown in (a) of Figure 30, the developer
10 accommodating container 37 for accommodating the
developer is constituted by the developer bag 16 and
the sealing member 19 for sealing the plurality of
openings 35a for permitting the discharge of the
developer and for exposing the openings 35a by being
15 moved. The developer bag 16 of the developer
accommodating container 37 for accommodating the
developer includes the filling opening 39 for
permitting the filling of the developer and the
openings 35a for permitting the discharge of the
20 developer. The openings 35a are provided to the
developer bag 16 at a plurality of positions.

[0070] Here, in the developer accommodating container
37 for accommodating the developer, the developer is
not filled as yet, and the developer accommodating
25 container 37 is in a state in which the filling
opening 39 for permitting the filling of the developer
is open.

(Filling and developer accommodating container)

[0071] A relation between the developer accommodating container 37 for accommodating the developer and the developer accommodating container 26 in which the developer is accommodated will be described.

[0072] First, as shown in (a) of Figure 30, the developer accommodating container 37 for accommodating the developer is not filled with the developer and is provided with the filling opening 39 for permitting the filling of the developer.

[0073] Next, as shown in (b) of Figure 30, the developer is filled from the filling opening 39, for permitting the filling of the developer, of the developer accommodating container 37 for accommodating the developer. Further, by flexibility of the developer bag 16, the filling opening 39 for permitting the filling of the developer is deformable correspondingly to a filling device and thus the filling of the developer is facilitated without causing scattering of the developer. For filling the developer, a known auger type filling device is used but another method (means) having a similar function may also be used.

[0074] Then, as shown in (c) of Figure 30, the filling opening 39 for permitting the filling of the developer is bonded and sealed. The bonding of the bonding portion 39a of the opening for permitting the

filling of the developer is made by ultrasonic bonding in this embodiment but may also be made by other bonding methods using heat, a laser and the like.

[0075] Then, when the bonding of the bonding portion
5 39a of the opening for permitting the filling of the developer is completed, the developer is filled in the developer bag 16, so that the developer accommodating container 26 in which the developer is accommodated is provided.

10 [0076] A position and a size of the filling opening 39 for permitting the filling of the developer may appropriately selected correspondingly to shapes and the like of the developer filling device and the process cartridge A.

15 (Effect of incorporating developer bag in developing device)

[0077] By forming the developer accommodating container 26, in which the developer is accommodated, in a bag shape, the developer can be treated as a unit.
20 For that reason, a developer filling step can be separated from a main assembling step (manufacturing line) of the process cartridge A. As a result, the developer is prevented from being scattered in the main assembling step (manufacturing line) of the
25 process cartridge A, so that maintenance such as cleaning of the manufacturing line can be reduced. By the prevention of the scattering of the developer

during the assembling step, it is possible to omit a cleaning step of the process cartridge A to be performed after the developer filling.

[0078] Also in the filling step of the developer in
5 the developer bag 16, the developer bag 16 has flexibility, and thus the filling opening 39 for permitting the developer filling is also soft and therefore can be easily sealed with less scattering of the developer.

10 [0079] Further, the developer accommodating container 26 in which the developer is accommodated has flexibility and therefore can be assembled while following a shape of the frame.

[0080] Further, in the filling step, the developer
15 accommodating container 27 has flexibility and therefore deforms its cross section to increase its volume in which the developer can be filled, so that a filling amount can be increased during the filling.

[0081] Further, the developer accommodating container
20 37 before the filling with the developer has flexibility and thus can be made small (thin), so that a storing space during storage before the filling can be decreased compared with the frame which is a resinous structure.

25 (Structure of developer bag)

[0082] As shown in Figures 3 and 4, the developer bag 16 accommodating the developer therein and has a

bag-like shape which is deformable, and is provided with the plurality of openings 35a at the discharging portion 35 for permitting the discharge of the accommodated developer.

5 [0083] Further, the developer bag 16 includes developer bag fixing portions (portions-to-be-fixed) 16d and 16e fixed to the first frame 17 and the second frame 18.

(Material and air permeability of developer bag)

10 [0084] Parts (a) to (c) of Figure 29 are sectional views for illustrating the developer accommodating container 26. As shown in (a) of Figure 29, the developer bag 16 is constituted by bonding a sheet 16u which includes the discharging portion 35 and does not
15 have air permeability and a sheet 16s which has the air permeability and which is an air permeable portion to each other.

[0085] Here, a degree of the air permeability of the air permeable portion (sheet) 16s may appropriately
20 selected so that the developer is prevented from leaking out of the developer bag 16 based on a balance with a size of the developer (particle size of powder) to be accommodated.

[0086] As a material for the air permeable portion
25 16s, a nonwoven fabric or the like formed of polyethylene telephthalate (PET), polyethylene (PE), polypropylene (PP) or the like in a thickness of

0.03 - 0.15 mm may preferably be used. Further, even when the material for the air permeable portion 16s is not the nonwoven fabric, a material having minute holes which is smaller in diameter than the powder
5 such as the developer accommodated in the developer bag 16 may also be used.

[0087] Further, in this embodiment, as shown in Figures 3 and 29, the air permeability portion 16s is disposed over the entire region of the developer bag
10 16 with respect to a longitudinal direction in the second frame 18 side. As shown in (b) of Figure 29, the air permeable portion 16s may also constitute the entire developer bag 16.

[0088] As a material for the developer bag 16 other
15 than the air permeable portion 16s, a material having flexibility so as to improve an efficiency during the discharge of the developer described later may preferably be used. Further, the material for the air permeable portion 16s may also have flexibility.

20 (Effect of developer bag having air permeability)

[0089] The reason why the air permeability is imparted to the developer bag 16 as described above is that the developer bag 16 can meet states during manufacturing, during transportation until a user uses
25 the cartridge A, and during storage. First, the reason for the state during the manufacturing is that the developer bag 16 is made deformable and reducible in

order to facilitate assembling the developer bag 16 with the frames 17 and 18. In the case where the developer bag 16 is not provided with the air permeability portion 16s, the size thereof cannot be changed from that in a state in which the developer bag 16 is filled with the developer (the developer bag 16 is closed) and therefore the developer bag 16 is not readily deformed. For that reason, it takes time to assembly the developer bag 16 and the step is complicated. Therefore, when the air permeability is imparted to at least a part of the developer bag 16, the size of the developer bag 16 can be changed from that in the state in which the developer bag 16 is filled with the developer and then is closed, thus facilitating the assembling of the developer bag 16.

[0090] Next, the reason for the states during the transportation and during the storage is that the developer bag 16 can meet a change (difference) in air pressure between the inside and outside of the developer bag 16 during the transportation and during the storage of the process cartridge A. The difference in air pressure between the inside and outside of the developer bag 16 is generated in the case where the developer bag 16 is in a lower air-pressure environment during the transportation or the like than during the manufacturing or in the case where the developer bag 16 is stored at a higher temperature

than during the manufacturing. For that reason, by expansion of the developer bag 16, there is a possibility that parts contacting the developer bag 16 are deformed or broken. Therefore, there is a need to control the air pressure and the temperature during the transportation and during the storage, so that facilitates for that purpose are required and a cost is increased. However, problems caused due to the difference in air pressure between the inside and outside of the developer bag 16 can be solved by partly imparting the air permeability to the developer bag 16.

[0091] Further, in the case where the nonwoven fabric is provided with the discharging portion 35 and a bonding portion 22 at a periphery of the discharging portion 35, there is a possibility that fibers of the nonwoven fabric fall out with peeling of the sealing member 19 during unsealing and then enter the developer to adversely affect the image. For that reason, the discharging portion 35 is provided to the sheet 16u different from the sheet 16s having the air permeability, so that the above-described falling-out of the fibers from the nonwoven fabric is prevented.

[0092] Further, a filling density can be increased by filling the developer while deaerating the developer bag 16.

(Structure of discharging portion of developer bag)

[0093] As shown in Figures 3 and 10, the developer bag 16 includes the developer discharging portion 35 consisting of the plurality of openings 35a for permitting the discharge of the developer therein and the connecting portion 35b defining the plurality of openings 35a. Further, the discharging portion 35 is continuously surrounded by a bonding portion 22 to be unsealably bonded, so that the developer accommodated in the developer bag 16 is sealed with the sealing member 19.

(Structure of bonding portion of developer bag)

[0094] The bonding portion 22 has a rectangular shape consisting of two lines extending in a long direction (arrow F direction) and two lines extending in a short direction (arrow E direction) so as to surround the discharging portion 35 and therefore the bonding portion 22 enables the sealing of the discharging portion 35.

[0095] Here, of the two lines of the welded bonding portion 22 extending in the long direction (arrow F direction), a bonding portion which is first unsealed is referred to as a first bonding portion 22a and a bonding portion which is unsealed later is referred to as a second bonding portion 22b. In this embodiment, in the case where the bonding portion 22 is viewed along the surface of the sealing member 19, a bonding portion closer to a fold-back portion 19d (or

portion-to-be-engaged 19b) described later is a first bonding portion 22a. Further, a bonding portion opposing the first bonding portion 22a via the opening 35a is a second bonding portion 22b. Further, a bonding portion with respect to a widthwise direction (arrow E direction) is a widthwise bonding portion 22c.

[0096] In this embodiment, an unsealing direction is the arrow E direction. The unsealing direction is defined as follows. In the case where the unsealing is effected by moving the sealing member 19, of the first bonding portion 22a and the second bonding portion 22b opposing to each other via the opening 35a, the first bonding portion 22a is first unsealed (peeled). Thus, a direction directed from the first bonding portion 22a to be first unsealed toward the second bonding portion 22b is the unsealing direction (arrow E direction).

[0097] When the sealing member 19 is unsealed (peeled) from the developer bag 16 in the arrow E direction, in some cases, the peeling microscopically progresses also in the arrow F direction due to the deformation of the developer bag 16 by an unsealing force also in the first bonding portion 22a and the second bonding portion 22b. However, the unsealing direction in this embodiment does not refer to such a microscopic unsealing direction.

(Disposition of openings of developer bag)

[0098] Next, disposition of the openings 35a will be described with reference to Figures 10, 11 and 30. The movement direction of the sealing member 19 for sealing the openings 35a and for exposing the openings 5 35a by being moved (i.e., a direction in which the sealing member 19 is pulled by the rotatable member 20)) is an arrow D direction. By the movement of the sealing member 19, the exposure of the openings 35a progresses in the unsealing direction (arrow E 10 direction). In the following, the movement direction of the sealing member 19 is the arrow D direction.

[0099] The plurality of openings 35a and the plurality of connecting portions 35b are alternately disposed along the direction (arrow F direction) 15 perpendicular to the unsealing direction (arrow E direction). Further, the sealing member 19 is configured to be wound up by rotating the unsealing member 20 but the arrow F direction is the same direction as an axis (axial line) of the rotation 20 shaft of the unsealing member 20.

[0100] The reason why the rotational axis direction of the developing roller 13 and the arrangement direction (arrow F direction) of the plurality of openings 35a are made equal is that the developer is 25 easily supplied, during the discharge thereof, to the developing roller 13 over the entire longitudinal direction without being localized.

[0101] The plurality of openings 35a are shifted and disposed along the arrow F direction and therefore the discharging portion 35 is long in the arrow F direction and is short in the arrow E direction. That is, with respect to the arrow F direction, a distance from an end to another end of the plurality of openings 35a is longer than that with respect to the arrow E direction.

[0102] Thus, the discharging portion 35 where the plurality of openings 35a are shifted and disposed in the direction (arrow F direction) perpendicular to the unsealing direction (arrow E direction) is long in the arrow F direction and is short in the arrow E direction. For that reason, the distance required for the unsealing can be made shorter than that required for the unsealing in the long direction (arrow F direction) and therefore a time required for the unsealing can also be made short.

[0103] Further, a constitution in which the sealing member 19 for covering the discharging portion 35 is wound up by the unsealing member 20 is employed. The rotational axis direction of the unsealing member 20 and the direction (arrow F direction) substantially perpendicular to the unsealing direction (arrow E direction) are made equal, so that winding distance and time of the sealing member 19 can be shortened. (Shape and direction of openings of developer bag)

[0104] Each of the plurality of openings 35a in First Embodiment has a circular shape. When a discharging property is taken into consideration, an area of the openings 35a may preferably be large. Further, the connecting portions 35b defining the openings 35a may preferably be large (thick) in order to enhance the strength of the developer bag 16. Therefore, the area of the openings 35a and the area of the connecting portions 35b are required to achieve a balance in view of a material and a thickness of the discharging portion 35 and a force relationship with peeling strength during the unsealing described later and may be appropriately selected. The shape of each opening 35a may also be, in addition to the circular shape, a polygonal shape such as a rectangular shape, an elongated circular shape as shown in Figure 18 in Fourth Embodiment described later, and the like shape.

[0105] The arrangement of the openings 35a may only be required to be such that the openings 35a are shifted (spaced) with respect to the direction (arrow F direction) perpendicular to the unsealing direction (arrow E direction). Even when the adjacent openings 35a overlap with each other, as shown in (c) of Figure 28, as seen in the direction (arrow F direction) perpendicular to the unsealing direction (arrow E direction) or do not overlap with each other, as shown in (d) of Figure 28, as seen in the direction (arrow F

direction), an effect of the connecting portions 35b described later is achieved.

[0106] Further, the direction of the openings 35a may preferably be such that the developer accommodated in
5 the developer bag 16 is easily discharged in an attitude during image formation. For that reason, in the attitude during image formation, the openings 35a are disposed so as to be open downward with respect to the gravitational direction. The state in which the
10 openings 35a open downward with respect to the gravitational direction refers to that the direction of the openings 35a has a downward component with respect to the gravitational direction.

(Fixing between developer bag and frame)

15 [0107] As shown in Figures 3 and 4, the developer bag 16 is fixed inside the first frame 17 and the second frame 18 by the fixing portions 16d and 16e.

(First fixing portion)

[0108] First, as a first fixing portion, the first
20 fixing portion 16d of the developer bag 16 where a force is received when the sealing member 19 is unsealed (removed) from the developer bag 16 as described later is provided. The first fixing portion 16d is provided at a plurality of positions in
25 parallel to the direction (arrow F direction) along which the plurality of openings 35a are arranged. Different from the arrangement at the plurality of

positions, the first fixing portion 16d may also be a single fixing portion elongated in parallel to the arrow F direction (not shown).

[0109] The first fixing portion 16d is positioned in the neighborhood of the openings 35a of the developer bag 16.

[0110] The first fixing portion 16d of the developer bag 16 is fixed to a first fixing portion 18a of the frame.

10 [0111] The first fixing portion 16d is a fixing portion necessary for the time of unsealing the developer bag 16, and its action and arrangement will be described later in the description of the unsealing. (Second fixing portion)

15 [0112] Further, as a second fixing portion, the second fixing portion 16e for preventing movement of the developer bag 16 downward or toward the developing roller 13 and the developer supplying roller 23 is provided.

20 [0113] The second fixing portion 16e is provided for the following two reasons. A first reason is that the second fixing portion 16e of the developer bag 16 is prevented from moving the developer bag 16 downward in the attitude during the image formation. For that
25 reason, the second fixing portion 16e may preferably be disposed at an upper position in the attitude during the image formation.

[0114] Further, a second reason is that the developer bag 16 is prevented from disturbing the image in contact with the developing roller 13 and the developer supplying roller 23 during the image formation. For that reason, the second fixing portion 16e of the developer bag 16 may preferably be provided at a position remote from the developing roller 13 and the developer supplying roller 23. In this embodiment, the second fixing portion 16e of the developer bag 16 is disposed at an upper position remote from the developing roller 13 as shown in Figure 4.

[0115] The second fixing portion 16e of the developer bag 16 is fixed to a second fixing portion 18b of the frame.

(Fixing method between developer bag and frame)

[0116] A fixing method between the developer bag 16 and the frame will be described with reference to Figures 27 and 4. Parts (a) to (d) of Figure 27 are illustrates of the fixing portion of the developer accommodating container.

(Fixing method of first fixing portion)

[0117] As a fixing method of the first fixing portion 16d of the developer bag 16, fixing by ultrasonic clamping such that a boss of the second frame 18 is passed through the hole of the developer bag 16 to be deformed is used. As shown in (a) of Figure 27, before fixing, the first fixing portion 18a of the second

frame 18 has a cylindrical boss shape, and the first fixing portion 16d of the developer bag 16 has a hole which is open. An assembling step is described below.

[0118] First, a projected portion of the first fixing portion 18a of the second frame 18 is passed through the hole of the first fixing portion 16d of the developer bag 16 ((b) of Figure 27).

[0119] Then, an end of the first fixing portion 18a of the second frame 18 is fused by a ultrasonic clamping tool 36 ((c) of Figure 27).

[0120] Then, the end of the first fixing portion 18a of the second frame 18 is deformed so that it is larger than the hole of the first fixing portion 16d of the developer bag 16, and thus the developer bag 16 is fixed to the second frame 18 ((d) of Figure 27).

(Fixing method of second fixing portion)

[0121] As shown in Figure 4, as a fixing method of the second fixing portion 16e of the developer bag 16, clamping by the two frames 17 and 18 is used. Holes are made in the developer bag 16 to constitute the first fixing portion 16e of the developer bag 16, and projections are provided to the second frame 18 to constitute the second fixing portion 18b of the frame.

[0122] An assembling step is as follows. The second fixing portion (projections) 18b of the second frame 18 is passed through the second fixing portion (holes) 16e of the developer bag 16, and then the developer

bag 16 is clamped by the first frame 17 so that the second fixing portion (holes) 16e of the developer bag 16 is not disengaged (dropped) from the second fixing portion (projections) 18b to be fixed.

5 (Other fixing means)

[0123] As other fixing means, different from the above-described ultrasonic clamping, it is also possible to use fixing means using ultrasonic wave. For example, heat clamping using heat, (heat) welding
10 or ultrasonic welding for directly welding the developer bag 16 to the first frame 17 or the second frame 18, bonding using a solvent or an adhesive, insertion of the developer bag 16 between the frames, hooking using the heat clamping, the ultrasonic
15 clamping, a screw, or a combination of holes and projections (such as bosses), and the like means may also be used. Further, the developer bag 16 may also be fixed via a separate member provided between the first and second frames 17 and 18 depending on
20 appropriate design based on relationships in space, arrangement or the like between the developer bag 16 and the first and second frames 17 and 18 (not shown).
<Structure of sealing member>

[0124] As shown in Figures 3 and 4, the sealing
25 member 19 covers the discharging opening 35 of the developer bag 16 before use of the cartridge A to confine the developer in the developer bag 16. The

sealing member 19 is moved, so that the openings 35a are exposed. The sealing member 19 is constituted by a sheet-like sealing member including a sealing portion 19a for covering (sealing) the discharging portion 35 of the developer bag 16, a portion-to-be-engaged 19b to be fixed (engaged) with the unsealing member 20 described later, and a sealing member connecting portion 19c which connects the sealing portion 19a and the portion-to-be-engaged 19b. The sheet-like sealing member is formed of a laminate material having a sealant layer which exhibits an easy-unsealing property described later, and a base material therefor is polyethylene telephthalate (PET), polyethylene, polypropylene or the like. A thickness of the sheet-like sealing member may appropriately be set in a range of 0.03 - 0.15 mm.

(Sealing portion of sealing member)

[0125] A sealing portion 19a refers to a region where the sealing member 19 seals the plurality of openings 35a and connecting portions 35b of the developer bag 16. By the sealing portion 19a, the developer is prevented from being leaked from the inside of the developer bag 16 until before use of the process cartridge A.

(Engaging portion of sealing member)

[0126] The sealing member 19 has a free end portion in one end side thereof with respect to the unsealing

direction (arrow E direction) and at the free end
portion, the portion-to-be-engaged 19b to be engaged
with the unsealing member 20 for moving the sealing
member 19 is provided. With the portion-to-be-engaged
5 19b, the unsealing member 20 for moving the sealing
member 19 so as to expose the openings 35a is engaged.
The unsealing member 20 may also be configured to
automatically perform the unsealing by receiving a
driving force from the image forming apparatus main
10 assembly B. Or, the unsealing member 20 may also be
configured to perform the unsealing by being held and
moved by the user. In this embodiment, the unsealing
member 20 is a rotation shaft provided in the frame,
and the sealing member 19 engaged with the unsealing
15 member 20 is pulled, so that the developer
accommodating container 26 accommodating the developer
is unsealed.

(Sealing member connecting portion of sealing member)

[0127] A portion for connecting the bonding portion
20 22 and the sealing member engaging portion
(portion-to-be-engaged) 19b is the sealing member
connecting portion 19c. The sealing member connecting
portion 19c is a portion for transmitting a force so
as to pull off the bonding portion 22 by receiving the
25 force from the unsealing member 20.

(Folding-back of sealing member connecting portion)

[0128] Referring to Figure 12, a surface formed

between the first bonding portion 22a and the second bonding portion 22b at the movement of the unsealing is taken as N1. A surface which is perpendicular to the surface N1 and which passes through the first bonding portion 22a is taken as N2.

[0129] The unsealing member 20 is disposed in the second bonding portion 22b side more than the surface N2 passing through the first bonding portion 22a. In other words, the sealing member 19, when it is seen along the surface of the sheet-like sealing member 19, includes a fold-back portion 19d where the sealing member 19 is folded back at the portion (connecting portion 19c) between the connecting portion 22 and the portion-to-be-engaged 19b engaged with the unsealing member 20. The fold-back portion 19d may be provided with or not provided with a fold (crease). A folding angle Q of the sealing member 19 may preferably be 90 degrees or less. The folding angle Q is a narrow angle Q between a surface of the bonding portion 22 of the developer bag 16 and a surface along the direction (arrow D direction) in which the sealing member 19 is pulled.

(Fixing of sealing member)

[0130] Further, fixing between the sealing member 19 and the unsealing member 20 is, in this embodiment, made by the ultrasonic clamping similarly as in the case of the first fixing portion 16d. Other than the

ultrasonic clamping, the fixing may also be made by
the (heat) welding, the ultrasonic welding, the
bonding, the insertion between the frames, the hooking
by a hole and a projection, or the like similarly as
5 the means for fixing the first fixing portion 16d and
the second fixing portion 16e.

(Portion having easy-unsealing property of sealing
member)

[0131] A method of providing a peeling force of the
10 bonding portion 22 with a desired value will be
described. In this embodiment, in order to provide the
peeling force with the desired value (a minimum force
within a range in which the toner sealing property can
be maintained), two methods are principally employed.

15 [0132] In a first method, a laminate material having
a sealant layer for enabling easy unsealing of the
sealing member is applied. Further, the first method
is a method in which the easy unsealing is enabled at
the bonding portion by using, as the material for the
20 developer bag 16, a sheet material (of, e.g.,
polyethylene or polypropylene) which is weldable with
the sealant layer and which has flexibility. By
changing a combination of formulation of the sealant
layer with the material to be bonded, the peeling
25 force can be adjusted correspondingly to a desired
condition. In this embodiment, a material having a
peeling strength of about 3N/15 mm measured by testing

methods for heat sealed flexible packages (JIS-Z0238) is used.

[0133] A second method is a method in which as shown in Figures 4 and 7, the discharging portion 35 of the developer bag 16 is placed in a state in which the sealing member 19 is folded back with respect to an unsealing direction (arrow E direction in the figures). For example, in the state of Figure 4, the unsealing member 20 is rotated (in an arrow C direction), so that the sealing member 19 is pulled in a pulling direction (arrow D direction) by the unsealing member 20. As a result, the developer bag 16 and the sealing member 19 provide an inclined peeling positional relationship, as shown in Figure 12, in which the narrow angle Q between the surface of the bonding portion 22 of the developer bag 16 and the surface along the pulling direction (arrow D direction) of the sealing member 19 is 90 degrees or less. It has been conventionally known that the peeling force necessary to separate the both surfaces can be reduced by establishing the inclined peeling positional relationship. Therefore, as described above, the discharging portion 35 is placed in the state in which the sealing member 19 is folded back with respect to the unsealing direction (arrow E direction), so that the sealing member 19 of the bonding portion 22 and the developer bag 16 are placed in the inclined

peeling positional relationship and thus the peeling force can be adjusted so as to be reduced.

<Structure of unsealing member>

[0134] The unsealing member 20 is used for the purpose of peeling the sealing member 19 from the developer bag 16 by applying a force to the sealing member 19 to move the sealing member 19. The unsealing member 20 includes a supporting portion (not shown) which has a shaft shape and which is rotatably supported by the second frame 18 at its ends, and includes an engaging portion 20b to which the portion-to-be-engaged 19b of the sealing member 19 is to be fixed. In this embodiment, the unsealing member 20 has a rectangular shaft shape, and the portion-to-be-engaged 19b of the sealing member 19 is engaged with the engaging portion 20b at one of four surfaces of the rectangular shaft.

(Combined use as unsealing member, urging member and stirring member)

[0135] The urging member 21 for externally acting on the developer bag 16 to discharge the developer accommodated in the developer bag 16, and the unsealing member 20 may be separate members but in this embodiment, the same part performs functions of the unsealing member 20 and the urging member 21.

[0136] Further, a function of stirring the developer discharged from the developer bag 16 and a function of

the unsealing member 20 may be performed by separate members but in this embodiment, the unsealing member 20 also perform the stirring function of the stirring member.

5 (Effect of combined use as unsealing member, urging member and stirring member)

[0137] Thus, by using the same part (member) as the unsealing member 20, the urging member 21 and the stirring member, the number of parts is reduced, so
10 that it becomes possible to realize cost reduction and space saving.

<Summary of unsealing of developer bag>

[0138] The unsealing of the developer bag 16 will be described with reference to Figures 7 and 8.

15 [0139] For unsealing the developer bag 16, the developing device 38 includes a power application point portion 20a where the unsealing member 20 applies the force for pulling the sealing member 19, and includes the fixing portion 18a of the frame for
20 fixing the developer bag 16 to be pulled.

[0140] The power application point portion 20a is a portion, closest to the bonding portion 22, of a portion where the sealing member 19 and the unsealing member 20 contact at the moment of the unsealing. In
25 (b) of Figure 7, a corner portion 20c of the unsealing member 20 constitutes the power application point portion 20a. The fixing portion 18a of the second

frame 18 includes a fixing portion 18c for suppressing movement of the developer bag 16 caused by the force during the unsealing. In this embodiment, from the bonding portion 22, the first fixing portion 18a of the frame and the first bonding portion 16d of the developer bag 16 are bonded to each other by the ultrasonic clamping, and as shown in (b) and (c) of Figure 7 and (a) of Figure 8, a portion, closer to the bonding portion 22, of the first fixing portion 18a bonded by the ultrasonic clamping constitutes the fixing portion 18c.

[0141] As shown in Figure 4, the unsealing member 20 is rotated in the arrow C direction by transmission of the during force thereto from the main assembly by an unshown driving means.

[0142] A state immediately before the sealing member 19 is pulled by further rotation of the unsealing member 20 to start the unsealing is shown in Figure 5 and (c) of Figure 7. With the rotation, the sealing member 19 fixed to the unsealing member 20 by the portion-to-be-engaged 19b is pulled in the arrow D direction by the corner portion 20c (power application point portion 20a) of the rectangular unsealing member 20.

[0143] When the sealing member 19 is pulled, the developer bag 16 is pulled via the bonding portion 22. Then, a force is applied to the first fixing portion

16d of the developer bag 16, so that the developer bag 16 is pulled from the fixing portion 18c toward the power application point portion 20b by the fixing portion 18c. Then, in a cross section perpendicular to the rotation shaft of the unsealing member 20, the first bonding portion 22a is moved to approach a line connecting the power application point portion 20a and the fixing portion 18c. At this time, with respect to the arrow D direction, from a side close to the rotation shaft of the unsealing member 20, the portions are disposed in the order of the openings 35a, the first bonding portion 22a, the fold-back portion 19d and the fixing portion 18c ((b) of Figure 7). Further, the unsealing member 19 is folded back between the first bonding portion 22a and the portion-to-be-engaged 19b and therefore the force is applied to the portion of the first bonding portion 22a so as to be inclination-peeled in the arrow D direction. Then, the peeling of the first bonding portion 22a is effected to start the unsealing of the discharging portion 35.

[0144] Together with the corner portion 20c, also the power application point portion 20a is moved in the arrow C direction, and when the sealing member contacts a corner portion 20d, the power application point portion 20a is moved from the corner portion 20c to the corner portion 20d. Part (b) of Figure 7 shows

a state in which the power application point portion 20a is the corner portion 20c, and (c) of Figure 7 shows a state in which the unsealing member 20 is further rotated and thus the power application point
5 portion 20a is moved to the corner portion 20d.

[0145] As shown in Figure 6 and (c) of Figure 7, when the unsealing is advanced with further rotation of the unsealing member 20, also the fold-back portion 19d is moved in the arrow E direction. Then, the unsealing is
10 further advanced, so that the openings 35a are exposed. A state in which the peeling of the second bonding portion 22b is to be started after the openings 35a are exposed is shown in (a) of Figure 8. Also at this time, similarly as in the case of the peeling of the
15 first bonding portion 22a, the sealing member 19 is pulled toward the power application point portion 20a, and the developer bag 16 stands firm toward a direction of the fixing portion 18c (an arrow H direction). Then, in a cross section perpendicular to
20 the rotation shaft of the unsealing member 20, the second bonding portion 20b is moved to approach a line connecting the power application point portion 20a and the fixing portion 18c. Then, the force is applied to the portion of the bonding portion 22b in the arrow D
25 direction, so that the second bonding portion 22b is separated. Thus, the second bonding portion 22b is peeled to complete the unsealing ((b) of Figure 8 and

Figure 9). Then, the developer inside the developer bag 16 is discharged in an arrow I direction through the openings 35a of the discharging portion 35.

[0146] Thus, the sealing member 19 is wound up around
5 the unsealing member 20 by the rotation of the unsealing member 20, so that the bonding portion 22 is unsealed. The sealing member 19 is wound up by the rotation and therefore a space required to move the unsealing member 20 may only be required to be a
10 rotation space of the unsealing member 20, and compared with the case where the sealing member 19 is moved by movement other than the rotation, it is possible to realize space saving.

[0147] By providing the sealing member 19 with the
15 fold-back portion 19d, so that the bonding portion 22 can be inclination-peeled without using shearing peeling and thus can be unsealed with reliability.

[0148] Further, the portion-to-be-engaged 19b, to be
20 engaged with the unsealing member 20, for unsealing the sealing member 19 in an end side of the sealing member 19 with respect to a direction substantially perpendicular to the direction (arrow F direction in Figure 3) in which the plurality of openings 35a are arranged is provided, so that the sealing member 19
25 can be engaged and unsealed with reliability.

[0149] Further, by providing the frame with the developer bag 16, the developer bag 16 is supported by

the frame during the unsealing, so that even a soft and deformable developer bag 16 becomes unsealable with reliability.

[0150] With respect to the discharge of the developer during the unsealing, as described above, the bonding portion 22 is moved along the line connecting the power application point portion 20a and the fixing portion 18c (in the order of (a) of Figure 7, (b) of Figure 7, (c) of Figure 7 and (a) of Figure 8). By this motion, the developer at the periphery of the openings 35a is moved, so that agglomeration of the developer can be broken.

(Positional relation of fixing portion associated with unsealing)

[0151] As shown in Figure 4, in order to peel off the first bonding portion 22b with reliability, the following positional relation is required between the first bonding portion 22b and the fixing portion 18c. During the unsealing, with respect to the fixing portion 18c, the unsealing member 20 pulls the sealing member 19 in the arrow D direction. At this time, with respect to the movement direction (arrow D direction) of the sealing member 19 by the unsealing member 20, the fixing portion 18c is provided upstream of the openings 35a. For that reason, as shown in Figure 5, a force is applied to the fixing portion 18c in the arrow H direction. Therefore, when the unsealing force

is applied, the sealing member 19 is pulled in the arrow H direction and the arrow D direction between the fixing portion 18c and the unsealing member 20 to apply a force to the first bonding portion 20a, thus
5 advancing the unsealing. Thus, when the fixing portion 18c is not provided upstream with respect to the movement direction (arrow D direction) of the sealing member 19, the entire developer bag 16 is pulled in the direction in which the sealing member 19 is pulled,
10 so that the force cannot be applied to the first bonding portion 22a and thus the first bonding portion 22a cannot be unsealed.

[0152] In this way, the fixing portion 18c is provided upstream with respect to the movement
15 direction (arrow D direction) of the sealing member 19, so that reliable unsealing becomes possible.

(Distance relation of fixing portion associated with unseal)

[0153] As shown in Figures 22 and 23, in order to
20 peel off the first bonding portion 22b with reliability, the following length relationship is required between the first bonding portion 22a and the fixing portion 18c. First, a point of the first bonding portion 22a finally peeled off when a flat
25 surface which passes the unsealing member 20, the openings 35a and the fixing portion 18c and which is perpendicular to the rotation shaft of the unsealing

member 20 is viewed, is taken as a first point 22d.
The first point 22d is an end point of the first
bonding portion 22a close to the openings 35a. A
distance from the fixing portion 18c to the first
5 point 22d along the developer bag 16 is taken as M1. A
distance from the first fixing portion 18c to the
first point 22d along the developer bag 16 with
respect to the direction including the openings 35a is
taken as M2. The openings 35a provide a space in which
10 the material for the developer bag 16 is not present
but a width of the openings 35a is also included in
the distance M2.

[0154] In this case, a relationship of $M1 < M2$ is
satisfied to permit the peeling-off of the first
15 bonding portion 22a. The relationship of $M1 < M2$ will
be described specifically.

($M1 < M2$)

[0155] First, in the case where $M1 < M2$ is satisfied,
as shown in Figure 22, a force for pulling the sealing
20 member 19 toward the first bonding portion 22a (in the
arrow D direction) by the unsealing member 20 and a
retaining force of the fixing portion (in the arrow H
direction) are applied to the first bonding portion
22a, so that inclination peeling of the first bonding
25 portion 22a can be effected. By effecting the
inclination peeling, the peeling force can be set at a
low level. Part (a) of Figure 22 shows a state before

the unsealing, and (b) of Figure 22 shows a state immediately before the first bonding portion 22a is unsealed.

(M1 > M2)

5 [0156] On the other hand, in the case of $M1 > M2$, as shown in Figure 23, the pulling force by the unsealing member 20 is not applied to the first bonding portion 22a but is applied to the second bonding portion 22b. In this case, the force is not applied to the first
10 bonding portion 22a and therefore the first bonding portion 22a is not peeled. In this case, the force from the unsealing member 20 (in the arrow D direction) and the retaining force of the fixing portion 18c (in the arrow H direction) are applied to
15 the second bonding portion 22b. In this state, to the second bonding portion 22b, the force for pulling the sealing member 19 by the unsealing member 20 (in the arrow D direction) and the retaining force of the fixing portion 18c (in the arrow H direction) are
20 applied. At the portion of the second bonding portion 22b, the peeling relationship is a shearing peeling relationship and therefore it is difficult to unseal the second bonding portion 22b. This is because the shearing peeling requires a large force thereon that
25 of the inclination peeling.

[0157] Part (a) of Figure 23 shows a state before the unsealing, and (b) of Figure 23 shows a state when the

force for pulling the sealing member 19 by the unsealing member 20 (in the arrow D direction) is applied to the bonding portion (the second bonding portion in this case) by the rotation of the unsealing member 20. To the second bonding portion 22b, the force is applied but is applied based on the shearing peeling and therefore compared with the case of the inclination peeling, a very large force is required, so that it becomes difficult to reduce the peeling force.

(Distance in case where projection is present)

[0158] Definition of a manner of measuring the above-described distances M1 and M2 will be described. The distances M1 and M2 are important when the sealing member 19 is pulled during the unsealing. In the case where there is no projection (projected connecting portion) 16t (Figure 24) at an intermediate position of paths of M1 and M2, the distances developed as shown in Figures 22 and 23 may only be required to be measured. Further, in the case where there is the projection 16t formed, by bonding in manufacturing, at the intermediate position of the paths of M1 and M2, even when the sealing member 19 is pulled during the unsealing, the projection 16t is not elongated (peeled off) and therefore the portion of the projection 16t is not included in the distances M1 and M2. That is, the portion, such as the projection 16t, which does

not affect transmission of the force is not included in the distances M1 and M2.

[0159] As described above, based on the relationship of $M1 < M2$, the first bonding portion 22a is unsealed
5 earlier than the second bonding portion 22b. As a result, the fold-back portion 19d of the sealing member 19 is provided closer to the first bonding portion 22a. By this fold-back portion 19d, the peeling is not the shearing peeling but is the
10 inclination peeling. As a result, with reliability, the sealing member 19 can be peeled off from the developer bag 16, so that it is possible to provide an unsealable developing device 38.

(Plurality of fixing portions)

15 [0160] A relation between a plurality of fixing portions and the unsealing will be described with reference to (a) and (b) of Figure 31, wherein (a) of Figure 31 shows a state before the unsealing, and (b) of Figure 31 shows a state immediately before the
20 unsealing member 20 is rotated from the state of (a) of Figure 31 to unseal the first bonding portion 22a. In this embodiment, the first fixing portion 18a and the second fixing portion 18b are provided. The force during the unsealing is applied to the first fixing
25 portion 18a disposed at a place close to the first bonding portion 22a, which is first unsealed, spaced from the second bonding portion 22b via the openings

35a. For that reason, the second fixing portion 18b is not required to be taken into consideration in the measuring manners of the distances M1 and M2 (Figures 23 and 24) described above. Thus, in the case where
5 are the portion fixing portions, the unsealing is effected on the basis of the fixing portion disposed at the place close to the first bonding portion 22a, which is first unsealed, spaced from the second bonding portion 22b via the openings 35a to which the
10 force during the unsealing is to be applied.

(Positional relation of second bonding portion)

[0161] With reference to Figure 12 showing a state immediately before the first bonding portion 22a is unsealed, an arrangement in which the second bonding
15 portion 22b can be more satisfactorily unsealed without being wound up around the unsealing member 20 will be described. First, an end portion of the first bonding portion 22a remote from the openings 35a is taken as a second point 22e. An end portion of the
20 second bonding portion 22b remote from the openings 35a is taken as a third point 22f. A distance from the second point 22e to the third point 22f is taken as L1. A distance from the second point 22e to the power application point portion 20a is taken as L2. In this
25 case, the distances L1 and L2 are required to satisfy the relationship of $L1 < L2$.

[0162] This is because in the case where L1 is larger

than L2, the second bonding portion 22b reaches the power application point portion 22a before the peeling of the second bonding portion 22b is ended, and thus the second bonding portion 22b is wound about the unsealing member 20. Therefore, the force cannot be applied so as to peel off the sealing member 19 from the second bonding portion 22b. For that reason, it becomes difficult to unseal the sealing member 19 from the developer bag 16.

10 [0163] As described above, the relationship between the distance L1 and L2 is made to satisfy: $L1 < L2$, the sealing member 19 is satisfactorily unsealable without being wound about the unsealing member 20. (Function of connecting portions defining openings)

15 [0164] A summary of the connecting portions 35b, defining the openings 35a, which perform a large function in the unsealing operation of the developer bag 16 will be described.

[0165] Figure 11 is a schematic view of the discharging portion 35 when the peeling at the first bonding portion 22a to be first unsealed is ended to expose the openings 35a, and shows a state in which the peeling at the second bonding portion 22b is not ended. As described above, the discharging portion 35 includes the plurality of openings 35a shifted and disposed along the direction (arrow F direction) perpendicular to the unsealing direction (arrow E

direction) in which the exposure of the openings 35a is advanced. For that reason, also the plurality of connecting portions 35b defining the plurality of openings 35a are disposed along the arrow F' direction.

5 As a result, the plurality of connecting portions 35b connect the first bonding portion 22a and the second bonding portion 22b with respect to the unsealing direction (arrow E direction) of the openings 35a. For that reason, at the time of the state of (a) of Figure
10 8 in which the unsealing of the first bonding portion 22a is ended, the force for unsealing the second bonding portion 22b can be received by the first fixing portion 16d via the connecting portions 35b, so that the force for peeling off the sealing member 19
15 from the developer bag 16 can be transferred. That is, the forces are applied to the second bonding portion 22b in the arrow D direction and the arrow E direction, so that also at the second bonding portion 22b, the sealing member 19 is peelable.

20 [0166] A similar effect can be obtained also in cases other than the case where the openings 35a are arranged in the direction (arrow F direction) perpendicular to the unsealing direction (arrow E direction) as shown in (b) of Figure 28 as described
25 above. Even when the openings 35a are not completely arranged in the direction perpendicular to the unsealing direction as shown in (c) of Figure 28, the

connecting portions 35b can transmit the force, for peeling off the sealing member 19 from the developer bag 16, in an arrow P direction. Further, even when the openings 35 overlap each other with respect to the unsealing direction as shown in (d) of Figure 28, the connecting portions 35b can transmit the force, for obliquely peeling the sealing member 19 from the developer bag 16, in an arrow P direction. That is, the plurality of openings 35a may only be required to be shifted and disposed with respect to the direction (arrow F direction) perpendicular to the unsealing direction (arrow E direction).

[0167] Further, as shown in (b) of Figure 28, a portion including the connecting portions 35b provided at a periphery of the openings 35a may also be used as the bonding portion 22. Also in this case, by the presence of the connecting portions 35b, the force can be transmitted until the sealing member 19 is completely peeled off at the bonding portion 22, so that the unsealing is effected with reliability.

[0168] As for a relationship between the rotation shaft of the unsealing member 20 and the openings 35a, it can be said that the openings 35a are shifted and disposed in the direction (arrow F direction) of the rotation shaft of the unsealing member 20. As a result, the connecting portions 35b for connecting the first and second bonding portions 22a and 22b with respect

to the direction (arrow E direction) perpendicular to the rotation shaft of the urging member 20. The openings 35a may only be required to be shifted and disposed in the rotational axis direction (arrow F direction) of the unsealing member. Even when the openings 35a overlap with each other with respect to the rotational axis direction (arrow F direction) as shown in (b) of Figure 28 and do not overlap with each other completely with respect to the rotational axis direction (arrow F direction) as shown in (d) of Figure 28, the force can be transmitted in the arrow P direction and thus the effect of the connecting portions 35b can be achieved.

[0169] Thus, by the presence of the connecting portions 35b for connecting the first and second bonding portions 22a and 22b at the discharging portion 35 of the developer accommodating container 26 accommodating the developer and the developer accommodating container 30 including the unsealing member 20, the unsealing force of the unsealing member 20 can be transmitted until the second bonding portion 22b is unsealed, so that the discharging portion 35 can be unsealed with reliability.

[0170] A relationship between the openings 35a and the portion-to-be-engaged 19b of the sealing member 19 will be described (Figure 3). The portion-to-be-engaged 19b is provided in an end side

of the sealing member 19 with respect to the direction substantially perpendicular to the direction in which the plurality of openings 35a are arranged.

[0171] A relationship between the openings 35a and
5 the unsealing member 20 will be described (Figure 3). The unsealing member 20 is provided in an end side of the sealing member 19 with respect to the direction substantially perpendicular to the direction in which the plurality of openings are arranged.

10 [0172] Also in such a constitution, it is possible to obtain the effect of transmitting the unsealing force of the unsealing member 20 by the connecting portions 35b until the second bonding portion 22b is unsealed. (Example of connecting portions as separate member)

15 [0173] The connecting portions 35b defining the openings 35a may also be provided as a separate member (connecting members 16f) as shown in Figure 21. In this case, a constitution in which a single long opening 16a elongated in the direction (arrow F
20 direction) perpendicular to the unsealing direction (arrow E direction) and then the connecting members 16f as the separate member connecting both sides of the opening 16a along the unsealing direction (arrow E direction) are provided on the opening 16a is employed.
25 At this time, the connecting members 16f are bonded in each of the first bonding portion 22a side and the second bonding portion 22b side of the opening 16a by

adhesive bonding, welding or the like.

[0174] Also in the case where the developer bag 16 is provided with the connecting members 16f, the sealing member 19 is folded back between the bonding portion 22 and the portion-to-be-engaged 18b as described above and is wound around the unsealing member 20, so that the developer bag 16 is unsealable. By employing such a constitution, the connecting portions 35b defining the openings 35a in the case where the plurality of openings 35a are provided, and the connecting members 16f perform the same function. That is, the single long opening 16a is the same as the plurality of openings 35a by providing the connecting members 16f.

[0175] Therefore, when the sealing member 19 is peeled at the second bonding portion 22b after the unsealing of the first bonding portion 22a is ended, the force (arrow D direction) during the unsealing of the second bonding portion 22b by the unsealing member 20 can be received by the first fixing portion 16d via the connecting members 16f with respect to the arrow H direction. Thus, the force for peeling the sealing member 19 from the developer bag 16 can be transmitted. That is, the forces are applied to the second bonding portion 22b in the arrow D direction and the arrow H direction, so that also the second bonding portion 22b is unsealable.

[0176] In this way, the single long opening 16a is combined with the connecting members 16f to form the plurality of openings 35a, so that it also becomes possible to strengthen only the connecting members 16f.

5 (Problem of unsealing property in case of no connecting portion)

[0177] An example in which the present invention is not applied and thus it is difficult to unseal the developer bag 16 will be described. This is the case
10 where there are no connecting portions 36b and thus it becomes difficult to unseal the developer bag 16 as shown in Figures 13, 14 and 15. Parts (a) and (b) of Figure 13 show an example in which there are no connecting portions 35b and a single long opening 16a
15 is provided. Part (a) of Figure 13 shows a state before the peeling at the second bonding portion 22b, and (b) of Figure 13 and Figure 15 show a state when the sealing member 19 is peeled at the second bonding portion 22b. Parts (a) and (b) of Figure 8 are
20 enlarged sectional views of the openings 35a and their periphery in states before and after the sealing member 19 is peeled at the second bonding portion 22b in this embodiment, and (a) to (c) of Figure 14 are sectional views of the opening 16a and its periphery
25 in the case where there are no connecting portions 35b and thus it becomes difficult to unseal the developer bag 16.

[0178] In this case, a state in which the unsealing is advanced to the second bonding portion 22b is shown in (a) of Figure 14, and from this state, the sealing member 19 is pulled and moved in the arrow D direction by further rotation of the unsealing member 20. Then, since there are no connecting portions 35b, the force from the first fixing portion 16d cannot be transmitted to the second bonding portion 22b side at the central portion of the opening 16a. For that reason, as shown in (b) of Figure 14 and (b) of Figure 13, a binding force of the fixing portion 18a of the frame to the second bonding portion 22b is eliminated, so that the opening 16a gradually opens largely in the arrow D direction. Further, the second bonding portion 22b is pulled by the sealing member 19, so that the opening 16a is deformed as shown in (c) of Figure 14. In this case, a force acting on the second bonding portion 22b fails to provide the inclination peeling positional relationship as shown in Figure 8 and causes the shearing peeling (approximately 0-degree peeling) by the deformation of the opening 16a as shown in (c) of Figure 14, so that there is a need to apply a large force for the peeling. In addition, the supporting force of the first fixing portion 16d cannot be transmitted to the second bonding portion 22b and therefore the second bonding portion 22b is pulled by the unsealing member 20 without causing the

peeling of the sealing member 19 therefrom. For that reason, the opening 16a in the neighborhood of a longitudinal central portion of the second bonding portion 22b further opens largely, so that the second bonding portion 22b is wound about the unsealing member 20.

[0179] Incidentally, when a developer accommodating member is a rigid structure, there is no such a deformation, so that the sealing member is unsealable as in the conventional example. However, in the case of a constitution in which the developer is accommodated in a soft deformation bag-like member and an opening which is deformed during unsealing is unsealed, as described above, when there are no connecting portions 35b, it is difficult to effect the unsealing.

[0180] As described above, the sealing member 19 (toner seal) is made unsealable transmitting the driving force to the unsealing member 20 of the image forming apparatus main assembly B and thus there is no need for the user to peel off the toner seal, so that the developing device 38 and the process cartridge A can be simply and easily replaced and used. Further, the sealing member 19 after the unsealing is fixed to the unsealing member 20, so that the unsealing can be effected without demounting a waste material from the process cartridge A.

<Summary of urging member and developer discharge>

[0181] The discharge of the developer by the urging member will be described with reference to the drawings.

5 (Urging member)

[0182] As shown in (a) to (d) of Figure 16, the urging member 21 includes a shaft portion 21a and an urging sheet 21b fixed to the shaft portion 21a and is provided rotatably inside the first frame 17 and the
10 second frame 18.

[0183] The shaft portion 21a performs a function by the same part as the unsealing member 20 (21a = 20). Therefore, as described above, the driving force is transmitted to the urging member 21 by the unshown
15 driving means of the image forming apparatus main assembly B, so that the urging member 21 (= 20) is rotated in the arrow C direction.

[0184] The urging sheet 21b is fixed on a surface of a rectangular shaft portion 21a in cross section and
20 is rotated together with the shaft portion 21a. The urging sheet 21b is a flexible sheet formed of a material such as PET, PPS (polyphenylene sulfide) or polycarbonate, in a thickness of about 0.05 - 0.1 mm, and an end thereof projects to the outside of a
25 circumscribed circle of the shaft portion 21a. In this embodiment, on different surfaces of the shaft portion 21a, the sealing member (first urging member) 19 and

the urging sheet (second urging member) 21b are fixed but may also be fixed on the same surface of the shaft portion 21a.

[0185] As shown in Figures 16 and 17, the urging sheet 21b also performs the function of stirring the developer and feeding the developer toward the developing roller 13 and the developer supplying roller 23.

<Summary of developer discharge from developer bag>

10 [0186] Next, the discharge of the developer from the developer bag will be described with reference to the drawings.

(Summary of discharge from before unsealing to during unseal)

15 [0187] First, the discharge of the developer from before the unsealing to the time of start of the unsealing will be described. As described above with reference to Figures 7 and 8, the sealing member 19 is pulled toward the power application point portion 20a
20 (in the arrow D direction), and the developer bag 16 is supported by the fixing portion 18c. For that reason, during unsealing, three places consisting of the power application point portion 20a, the fixing portion 18c of the frame and the place of the bonding
25 portion where the sealing member 19 is peeled and moved in a direction in which these three places are aligned in a rectilinear line in a cross section

perpendicular to the rotation shaft of the unsealing member 20. Thus, the position of the openings 35a is changed between the time before the unsealing member 20 applies the force to the sealing member 19 to perform the unsealing operation and the time when the unsealing operation is started to unseal the first bonding portion 22a, so that stagnation of the developer in the neighborhood of the openings 35a can be prevented and thus a discharging property is good.

10 (Summary of discharge after unsealing/during urging)
[0188] When the sealing member 19 is unsealed from the above-described developer bag 16 as shown in (b) of Figure 8, the openings 35a are disposed to open at a lower portion of the developer bag 16 and therefore
15 the developer in the neighborhood of the openings 35a is discharged by the action of gravitation and vibration or the like of the developer bag 16 during the unsealing.

[0189] After the unsealing, when the unsealing member
20 20 is further rotated, also the urging sheet 21b for urging the developer bag 16 fixed to the unsealing member 20 is rotated, so that the distance 21b is wound about the unsealing member 20 by the developer bag 16 as shown in Figure 9. As shown in Figure 16,
25 the urging sheet 21b has elasticity and therefore is likely to be restored to an original shape, thus urging the developer bag 16 in an arrow J direction.

At this time, the developer bag 16 is urged by the urging sheet 21b and is pressed against the second frame 18 via the toner, so that the entire developer bag 16 is deformed. The developer bag 16 is urged by the urging sheet 21b to be decreased in its inside volume. Thus, by the decrease in inside volume of and the change in entire shape of the developer bag 16, the developer inside the developer bag 16 is stirred and as a result, the developer is readily discharged from the openings 35a. At this time, the developer bag 16 is closed except for the openings 35a and thus there is no escape route except for the openings 35a, and therefore the discharging property from the openings 35a is high. By the discharging action as described above, the developer is readily discharged in the arrow I direction.

[0190] In the case, when the developer bag 16 is contacted to and pressed against the second frame 18 at least at a part thereof, the developer bag 16 is deformable.

[0191] By aligning the rotational axis direction of the developing roller 13 and the arrangement direction (arrow F direction) of the plurality of openings 35a, the developer can be easily supplied over the entire longitudinal direction of the developing roller 13 during the discharge without being localized.

[0192] When the developing device 38 is mounted in

the image forming apparatus main assembly B, by providing the openings 35a so as to open toward the direction of gravitation, the developer discharging property can be improved.

- 5 [0193] Further, the urging sheet 21 provided in the frames 17 and 18 urges the flexible container 16 so as to be pressed against the frame 18, so that the developer discharging property can be improved.

(Summary of discharge/developer bag shape restoration)

- 10 [0194] As shown in Figure 17, the unsealing member 20 is further rotated, so that the urging sheet 21b is separated from the developer bag 16. At this time, the developer bag 16 has flexibility and therefore is likely to be restored to the state before the urging
15 by the weight of the developer (arrow K direction).

- Then, also the urging sheet 21b is rotated and urges the developer bag 16 toward the second frame 18 as shown in Figure 16, so that the developer bag 16 is deformed to move the developer at a position other
20 than the neighborhood of the openings 35a and thus the developer is discharged from the openings 35a.

(Summary of discharge/Repetition of urging and restoration)

- [0195] In the case where the developer immediately
25 after the unsealing is accommodated in the developer bag 16 in a large amount, a penetration depth (entering amount) of the urging sheet 21b and the

unsealing member 20 with respect to the flexible container 16 is repetitively changed, so that the developer bag 16 is deformed so as to be pressed against the second frame 18. Contraction of the developer bag 16 by the urging with the urging member 21 and restoration of the shape of the developer bag 16 by the weight of the developer inside the developer bag 16 and by the flexibility of the developer bag 16 are repeated. Further, by the above-described action, the developer bag 16 itself is moved and therefore the developer bag 16 is vibrated, so that the developer inside the developer bag 16 is discharged from the openings 35a also by the vibration of the developer bag 16. The urging member 21 is rotated and therefore is capable of repetitively urging the developer bag 16.

(Example in which developer bag is applied to frame)

[0196] A portion 27 where the developer bag 16 is urged against the second frame 18 is as shown in Figure 25, even in the case where a bonding portion 28 such as an adhesive or a double-side tape is provided and bonds the developer bag 16 to the second frame 18, the urging sheet 21b can urge the developer bag 16 to discharge the developer.

(Case where amount of developer is small)

[0197] The case where the amount of the developer inside the developer bag 16 is decreased by image formation will be described with reference to (a) and

(b) of Figure 32. Immediately after the unsealing, as shown in (a) of Figure 32, the shape of the developer bag 16 follows a shape, defined by the urging member 21, in such a manner that the developer bag 16 always contacts the urging member 21 by the weight of the accommodated developer, so that a size (inside volume) is periodically changed. However, when the amount of the accommodated developer becomes small, as shown in (b) of Figure 32, the weight of the developer becomes light, so that the developer bag 16 does not follow the urging member 21 and thus repeats periodical separation from and contact with the urging member 21. For that reason, the size (inside volume) of the developer bag 16 is not so changed. For that reason, a developer discharging effect by the change in inside volume of the developer bag 16 is decreased but by the periodical contact between the developer bag 16 and the urging member 21, the developer bag 16 is vibrated and thus the developer can be discharged.

(Combined use as urging sheet and sealing member)

[0198] A single part may be used as the urging sheet 21b and the sealing member 19 to have functions of these members. After the unsealing, the bonding portion 22 is separated from the developer bag 16 and therefore an end of the sealing member 19 in the bonding portion 22 side is a free end. For this reason, the sealing member 19 can have the function of the

urging sheet 21b. Thus, the unsealing member 20 can have the function of the shaft portion 21a of the urging member 21, and the sealing member 19 can have the function of the urging sheet 21b. As a result, it is possible to reduce the number of parts and thus cost reduction can be realized.

[0199] As described above, the developer inside the developer bag 16 can be satisfactorily discharged without providing another discharging part such as a developer discharging roller at the openings 35a as a developer discharging port, so that agglomeration and bridge of the developer in the neighborhood of the openings 35a can be prevented. As a result, even in the case where the developer in the developer bag 16 is agglomerated by tapping during transportation, storage or the like, the agglomerated developer is broken by the movement of the entire developer bag 16 and the periphery of the openings 35a as described above, so that it is possible to prevent a state in which it is difficult to discharge the developer.

(Example of single part for urging member)

[0200] The urging member 21 is not constituted by separate parts consisting of the shaft portion 21a and the urging sheet 21b but may also be constituted by a single part, as shown in (a) of Figure 26, prepared by providing the urging member 21 integrally with a projection 21e functioning as the urging sheet 21b.

Also in this case, similarly, the developer can be discharged. In the case where the urging member 21 is constituted by only the shaft portion 21a, the developer bag 16 can be pressed against a frame 29 to be deformed even in the case where the cross section of the shaft portion 21a (urging member 21) has a polygonal shape ((b) of Figure 26) or has a cam shape ((c) of Figure 26) when the urging member 21 is viewed in its cross section perpendicular to its rotation center. This is because when the urging member 21 is disposed so as to contact at least the developer bag 16, a distance from the rotation center of the urging member 21 to the outer end of the urging member is changed and therefore the penetration depth of the urging member 21 with respect to the developer bag 16 is also changed. That is, so long as the shaft portion (urging member) is not a shaft portion having a circular cross section including the rotation shaft as its center, the developer bag 16 can be deformed by the rotation of the urging member 21. As shown in (a) of Figure 26, a distance 21c from the center of the urging member 21 to a remote outer end of the urging member 21 and a distance 21d from the center of the urging member 21 to a close outer end of the urging member 21 are different from each other and therefore the penetration depth of the urging member 21 with respect to the developer bag 16 is also changed.

[0201] Part (b) of Figure 33 is a sectional view of an urging member 21 having a cross-shape in cross section, and (a) of Figure 33 is a cross-sectional illustration of the developer accommodating unit 25 including the cross-shaped urging member 21. As shown in Figure 33, in the case where four projections 21e each having the same distance from the center of the urging member 21 to an associated outer end are provided, outer configurations (distance 21c) of the four projections 21e are the same. However, the urging member 21 includes a portion, other than the projections 21e, having an outer end (distance 21d) close to the center and therefore the penetration depth with respect to the developer bag 16 can be changed. That is, the urging member 21 can be constituted as a rotatable member including portions different in distance from its rotation center to its outer end in the cross section perpendicular to the rotation center of the urging member 21.

[0202] Thus, the developer bag 16 is unsealed by the urging member 21 (in the arrow J direction) to be pressed against the frame 29, thus being deformed to decrease its inside volume, so that the inside developer is pushed out to be discharged from the openings 35a (arrow I direction).

[0203] In an attitude during the image formation, the shaft portion 21a (= 20) of the urging member 21 is

positioned under the developer bag 16 in contact with the developer bag 16 with respect to the direction of gravitation. The cross-sectional shape of the shaft portion 21a (= 20) of the urging member 21 is

5 rectangular not is not circular and therefore by the rotation of the shaft portion 21a (= 20), the penetration depth of the shaft portion 21a (= 20) with respect to the developer bag 16 is periodically

10 changed as described above. Also by the change in penetration depth of the shaft portion 21a (= 20) with respect to the developer bag 16, the developer bag 16 can be changed in volume and can be vibrated, so that the developer discharging property can be improved.

<Summary of positional relationship between unsealing member and developer carrying member>

15

[0204] A positional relationship among the rotation shaft of the unsealing member 20, the sealing member 19 and the developer supplying roller 23 will be described. As shown in (c) of Figure 36, a distance

20 from the shaft center as the rotation center of the unsealing member 20 to the closest point on the surface of the developer supplying roller 23 is defined as X, and a maximum length from the shaft center of the unsealing member 20 to the free end of

25 the sealing member 19 when the sealing member 19 is unsealed is defined as T. The positional relationship will be described specifically below.

[0205] The sealing member 19 is the flexible sheet (first urging member) having elasticity and therefore is likely to be restored to the original sheet state even after being unsealed. Therefore, as shown in (b) of Figure 36, in the case where a relationship between the distance X and the length T satisfy: $X < T$, when the unsealing member 20 is rotated, the developer supplying roller 23 and the sealing member 19 contact each other every time when the free end of the sealing member 19 approaches the developer supplying roller 23. In this case, a coating state of the developer on the developer supplying roller 23 is disturbed by the contact of the sealing member 19 with the developer supplying roller 23, so that the disturbed portion is recognized as image non-uniformity when the image is outputted by the image forming apparatus.

[0206] Therefore, in this embodiment, as shown in (a) of Figure 36, a shielding member 42 is provided between the developer supplying roller 23 as the developer carrying member (developer feeding member) and the rotation shaft (shaft portion) of the unsealing member 20. As a result, every time when the sealing member 19 approaches the developer supplying roller 23, the free end of the sealing member 19 is bent and curved by the shielding member 42, so that the contact between the developer supplying roller 23 and the sealing member 19 can be prevented.

[0207] In this embodiment, as the urging member 21, a 0.05 mm-thick flexible PPS sheet is used and is provided under a setting condition such that the urging member 21 does not contact the shielding member 42. As shown in Figure 40, in the case where the unsealing member 19 is used also as the urging member 21, the urging member 21 is not present, so that its constitution is the same as that in this embodiment.

<Summary of structure of shielding member>

10 [0208] The shielding member 42 provided in this embodiment is of a rib-shaped type as shown in (a) of Figure 37. The developer accommodating unit 25 used in this embodiment has a longitudinal width of 240 mm. The shielding member 42 is a cylinder (cylindrical
15 shielding member) of 2 mm in diameter and 15 mm in widthwise height, and a plurality of shielding members 42 (5 shielding members in this embodiment) are disposed at an interval of 40 mm with respect to a longitudinal direction. That is, the shielding member
20 in this embodiment is configured so that the plurality of shielding members 42 for preventing contact of the sealing member 19 with the developer supplying roller 23 are provided at predetermined intervals to permit passing of the developer. Further, as shown in (a) of
25 Figure 37, the shielding members 42 are disposed to be present on a tangential line M, of the developer supplying roller 23, extending to the rotational axis

center of the sealing member 19. When the sealing member 19 contacts the shielding member 42, the sealing member 19 is bent, so that the contact between the developer supplying roller 23 and the sealing member 19 can be prevented.

[0209] However, there is no shielding member 42 between the rotation shaft of the unsealing member 20 and the developer supplying roller 23, i.e., also by the presence of the shielding member in the neighborhood thereof, it is possible to prevent contact of the sealing member 19 with the developer supplying roller 23. First, as shown in (a) of Figure 38, the sealing member 19 is bent by a shielding member 42a present upstream of the rotational direction. Then, as shown in (b) of Figure 38, during the contact between the shielding member 42a and the free end of the sealing member 19, a shielding member 42b present downstream of the rotational direction and a part of the sealing member 19 contact and thus a locus of the ends of the sealing member 19 is changed, so that it is possible to prevent the contact between the developer supplying roller 23 and the sealing member 19. The shielding member 42a and the shielding member 42b are of the rib-shaped type similarly as in the constitution of the shielding member 42 described with reference to (a) of Figure 37.

[0210] Further, (c) and (d) of Figure 38 show a

constitution in which only the shielding member 42a present upstream of the rotational direction is provided. In this constitution, first, as shown in (c) of Figure 38, a part of the sealing member 19 contacts the shielding member 42a to start bending and thereafter as shown in (d) of Figure 38, the free end of the sealing member 19 is to be separated from the shielding member 42a. At this time, the locus of the end of the sealing member 19 is changed, so that the contact between the developer supplying roller 23 and the sealing member 19 can be prevented.

[0211] Incidentally, when a spacing between the shielding member 42 and the developer supplying roller 23 is narrow and the shielding members (ribs) are small in the number thereof and are excessively wide in interval therebetween with respect to the longitudinal direction, at the time of the contact of the sealing member with the shielding member, the shielding member is bent at an intermediate position between the ribs in some cases. In this case, the developer supplying roller 23 and the sealing member 19 contact, so that there is possibility that a shielding effect (contact preventing effect) is not achieved. Therefore, when the developer accommodating unit 25 is intended to be downsized, there is need to pay attention also to setting conditions such as a widthwise disposition interval between the developer

supplying roller 23 and the shielding member 42, the number of ribs disposed with respect to the longitudinal direction of the shielding member 42, a longitudinal interval of the ribs, and the like.

5 Further, in this embodiment, there is a need to feed the developer to the neighborhood of the developer supplying roller 23 and therefore the shielding member 42 prevents the passing of the sealing member 19 but positively permits the passing of the developer.

10 [0212] The shape of the shielding member 42 may also be a rod shape in parallel to the rotation shaft of the unsealing member 20 as shown in (b) of Figure 37. Specifically, a plurality (three in this embodiment) of rod-like shielding members 42 of 240 mm in
15 longitudinal width and 2 mm in diameter are provided, so that the contact between the developer supplying roller 23 and the sealing member 19 can be prevented. Similarly as in the case of the rib shape of the shielding member shown in (a) of Figure 37, as shown
20 in (b) of Figure 37, the shielding member 42 is disposed to be present on a tangential line member, of the developer supplying roller 23, extending to the rotational axis center of the sealing member 19.

[0213] However, when the effect of preventing the
25 contact between the sealing member 19 and the developer supplying roller 23 is obtained, the position of the shielding member 42 is not limited to

the position between the rotation center of the sealing member 19 and the surface of the developer supplying roller 23, and there is no problem when the shielding member may also be disposed in the neighborhood of the position similarly as in the cases of (a) and (b) of Figure 38.

[0214] As a comparative example, in the case where the distance X and the length T satisfy $X > T$ as shown in (c) of Figure 36, even in the case where the end of the sealing member approaches the neighborhood of the developer supplying roller 23, both members do not contact each other. In this case, the disposing position of the rotation shaft of the unsealing member 20 is spaced apart from the developer supplying roller 23, so that a large space is provided between the unsealing member 20 and the developer supplying roller 23. That is, a position where the developer bag can be disposed is influenced by the position of the unsealing member 20 and therefore a dead space where the developer bag 16 cannot be disposed is formed in the developing device, so that there is a tendency that a developer filling rate in the developer accommodating unit is lowered.

[0215] On the other hand, in this embodiment, in the constitution in which the sealing member 19 can contact the developer supplying roller 23 due to downsizing or the like of the developing device, the

shielding member 42 is provided between the developer
supplying roller 23 and the unsealing member 20. As a
result, it is possible to prevent the contact between
the developer supplying roller 23 and the sealing
5 member 19. Further, in the case where the sealing
member contacts both of the developing roller 13 and
the developer supplying roller 23, by providing the
shielding member 42 both between the rotation shaft of
the unsealing member 20 and the developing roller 13
10 and between the rotation shaft of the unsealing member
20 and the developer supplying roller 23, it is
possible to prevent contact of the sealing member 19
with both of the developing roller 13 and the
developer supplying roller 23.

15 [0216] As described above, only by pulling the
sealing member 19 in the rotational axis direction
(arrow C direction in Figure 4) of the sealing member,
the unsealing can be effected, so that the developer
bag 16 can be stably unsealed with reliability.

20 Further, the unsealing can be effected by pulling the
sealing member 19 in the widthwise direction of the
process cartridge A and therefore a peeling distance
which was about two times the longitudinal length of
the conventional process cartridge can be remarkably
25 shortened. The sealing member 19 after the unsealing
is fixed to the unsealing member 20 and therefore the
unsealing can be effected without taking out the waste

material from the process cartridge. Further, the discharged of the developer from the inside of the developer bag 16 can be effected with reliability by the urging member 21. Further, the sealing member 19 can move together with the unsealing member 20 and therefore the toner stirring effect in the process cartridge can be expected. Further, the process cartridge free from causing the image defect resulting from the contact between the sealing member 19 as the urging member and the developer supplying roller 23 (developing roller 13) as the developer carrying member can be provided to the user without upsizing the developer accommodating unit.

[Second Embodiment]

15 [0217] Next, the case where the urging sheet 21b as a second urging member is in a positional relationship of contact with the shielding member 42 will be described. In this embodiment, in order to downsize the process cartridge while ensuring the developer supply, the positional relationship such that the urging sheet 21b contacts the shielding member 42 is established. Incidentally, in the positional relationship, the urging sheet 21b does not contact the developing roller 13 and the developer supplying roller 23. That is, when a length from the rotation center of the urging sheet 21b to the free end of the urging sheet 21b is defined as Y, the length Y of the

urging sheet 21b is constituted to be shorter than the length T of the sealing member and satisfy a relationship of $X > Y$ with the distance X.

[0218] The urging sheet 21b provided on the unsealing member 20 separately from the sealing member 19 as shown in Figure 16 also has the function of stirring the developer by its rotation to feed the developer toward the developing roller 13 and the developer supplying roller 23 and the function of uniformizing localization of the developer by impact or the like. For that reason, the urging sheet 21b requires a length in which the developer in the first frame 17 and the second frame 18 can be sufficiently stirred and therefore has a positional relationship of contact with the shielding member 42. Further, as the urging sheet 21b in this embodiment, in order to sufficiently exhibit the stirring property, a 0.05 mm-thick flexible PPS sheet having rigidity is used. For that reason, when the urging sheet 21b starts contact with the shielding member 42 with the rotation thereof, the shielding member 42 starts bending. When the urging sheet 21b is further rotated, the bent shielding member 42 is released at a stretch. At this time, flick sound is generated and is recognized as noise during operation.

[0219] In order to avoid the noise, the shielding member 42 is, as shown in (b) of Figure 16, provided

with a cut-away portion 43 in its free end side at a position where it contacts the shielding member 42. The cut-away portion 43 is provided so that the urging sheet 21b does not contact the shielding member 42. As a result, even in the case where the urging sheet 21b and the shielding member 42 are in the positional relationship of contact therebetween, it becomes possible to suppress the generation of the noise while maintaining the developer stirring effect. By using the constitution in this embodiment, there is no need to establish a non-contact positional relationship between the urging sheet 21b and the shielding member 42 in order to avoid the generation of the noise and therefore a downsized process cartridge and a downsized developer accommodating unit can be provided to the user. Incidentally, when the generation of the noise can be allowed to some extent, a cut-away portion 43 shown in (c) of Figure 16 or a cut-in portion 44 shown in (d) of Figure 16 are provided to the urging sheet 21b, so that the developer stirring property can be further improved while suppressing the generation of the noise.

[0220] In this embodiment, the constitution including, as the developer carrying member, the developing roller (developer carrying member) and the developer supplying roller 23 (developer feeding member) is exemplified but the present invention is not limited

thereto. For example, a constitution in which the developer supplying roller is not provided but only the developing roller is provided as the developer carrying member may also be employed. Further, the developing device including the flexible container for accommodating the developer and the urging member for urging the flexible container is exemplified but the present invention is not limited thereto. For example, a developing device which does not include the flexible container but includes a developer feeding member for feeding the accommodated developer may also be used. Also by such constitution, a similar effect can be obtained.

[Third Embodiment]

[0221] In the developing devices in First and Second Embodiments, the case where the non-magnetic toner is used and the developer supplying roller 23 is needed as the developer carrying member was principally described. In this embodiment, the case where the developer supplying roller 23 is not needed by providing a magnet roller (not shown), as the developer carrying member, inside the developing roller to effect developer feeding using a magnetic force will be described. Further, also the case where the developer is the non-magnetic toner but the developer supplying roller 23 is not needed is similarly included in this embodiment.

[0222] As shown in (b) of Figure 39, a distance from the shaft center of the unsealing member 20 to the closest point on the surface of the developing roller 13 is defined as X and this embodiment will be described specifically below. Further, similarly as in the case of (c) of Figure 36, the maximum length from the shaft center of the unsealing member 20 to the free end of the sealing member 19 after the unsealing is taken as T.

[0223] In this embodiment, as shown in (a) of Figure 39, the shielding member 42 is provided between the developing roller 13 and unsealing member 20. However, when the effect of preventing the contact between the sealing member 19 and the developing roller 13 is obtained, the position of the shielding member 42 is not limited thereto, and there is no problem when the position is located between the rotation shaft of the unsealing member 20 and the surface of the developing roller 13 or the neighborhood of these members.

[0224] As the urging member 21 in this embodiment, a 0.05 mm-thick flexible PPS sheet is used and is disposed under a setting condition of non-contact with the shielding member 42. Further, in the case where the sealing member 19 is used also as the urging member 21, there is no urging member and therefore its constitution is similar to that in this embodiment.

[0225] As shown in (b) of Figure 39, in the case

where a relationship between the distance X and the length T satisfy: $X < T$, when the unsealing member 20 is rotated, the developing roller 13 and the sealing member 19 contact each other every time when the free end of the sealing member 19 approaches the developing roller 13. In this case, a coating state of the developer on the developing roller 13 is disturbed by the contact of the sealing member 19 with the developer supplying roller 23, so that the disturbed portion is recognized as image non-uniformity when the image is outputted by the image forming apparatus. Therefore, as shown in (b) of Figure 39, by providing the shielding member 42, it becomes possible to downsize the process cartridge while preventing contact between the developing roller 13 and the sealing member 19. In this case, every time when the sealing member 19 approaches the developing roller 13, the free end of the sealing member 19 is bent and curved by the shielding member 42 and is configured to be in non-contact with the developing roller 13.

[0226] Further, the shielding member 42 is constituted to prevent the passing of the sealing member 19 but is constituted to positively permit the passing of the developer similarly as First and Second Embodiments.

[Fourth Embodiment]

[0227] As shown in Figures 18 and 19 and (c) of

Figure 29, in this embodiment, a developer accommodating member 34 is used in place of the developer bag 16 in First to Third Embodiments. The constitution and effect of the shielding member 42 are the same as those in First to Third Embodiments and will be omitted from detailed description.

(Vacuum molding)

[0228] Details of the developer accommodating member 34 will be described. The developer accommodating member 34 is formed by shaping a sheet-like material by vacuum molding, air-pressure molding and press molding, and is used. The developer accommodating container 30 including the unsealing member includes, similarly as in First Embodiment, the developer accommodating member 34, the sealing member 19, the unsealing member 20, the first frame 17 and the second frame 18. Incidentally, the unsealing member 20 is a member having the function of the urging member 21 and the developer stirring function similarly as in First Embodiment.

(Structure of developer bag)

[0229] As shown in Figure 18 and (c) of Figure 29, the developer accommodating member 34 is constituted by a molded portion 34a which is a flexible container formed by the vacuum molding, the air-pressure molding and the press molding and constituted by a sheet-like air permeable portion 34b. The molded portion 34a and

the air permeable portion 34b are bonded by (heat) welding, laser welding, adhesive bonding, adhesive tape bonding or the like. The reason why an air permeability is imparted to the developer

5 accommodating member 34 is that the developer accommodating member 34 meets states during manufacturing, during transportation and during storage similarly as in First Embodiment.

[0230] As the material for the molded portion 34a,
10 materials such as ABS, PMMA, PC, PP, PE, HIPS, PET, PVC and composite multi-layer materials of these materials may preferably be used. The thickness of the molded portion 34a in the sheet shape before the molding may preferably be about 0.1 - 1 mm. The
15 material and thickness of the molded portion 34a may appropriately selected depending on cost, product specification, manufacturing condition, and the like.

[0231] The molded portion 34a is bonded to the air permeable portion 34b at an outer peripheral portion
20 34c of the molded portion 34a. The developer accommodating member 34 accommodates the developer therein. Further, at a part of the outer peripheral portion 34c, a fixing portion 16d
(portion-to-be-fixed) of the developer accommodating
25 member 34 is provided. The shape of the molded portion 34a follows the inside shape of the frames 17 and 18 (Figure 19).

[0232] The developer accommodating container 26 in which the developer is accommodated is constituted by the developer accommodating member 34 and the sealing member 19 for unsealably covering the discharging
5 portion 35 of the developer accommodating member 34 to seal the toner inside the developer accommodating member 34.

[0233] The developer accommodating container 30 including the unsealing member is constituted by the
10 unsealing member 20 for unsealing the sealing member 19 from the developer accommodating member 34 and the developer accommodating container 26 in which the developer is accommodated.

[0234] The developing device 38 is constituted by the
15 developer accommodating container 30 including the unsealing member, the developing roller 13 as the developing means, the developing blade 15, and the first frame 17 and the second frame 18 which support these members.

[0235] The discharging portion 35 is provided at the
20 molded portion 34a. Also a constitution of this discharging portion 35 is the same as that in First Embodiment, and a plurality of openings 35a and a plurality of connecting portions 35b for defining the
25 plurality of openings 35a are provided with respect to the direction (arrow F direction) substantially perpendicular to the unsealing direction (arrow E

direction) in which the unsealing of the developer accommodating member 34 is advanced. That is, the plurality of openings 35a are shifted and disposed with respect to the direction (arrow F direction) perpendicular to the unsealing direction (arrow E direction). Further, the plurality of openings 35a are shifted and disposed with respect to the direction of the rotation shaft of the unsealing member 20. Further, the portion-to-be-engaged 19b is provided in an end side of the sealing member 19 with respect to the direction substantially perpendicular to the direction in which the plurality of openings 35a are arranged. Further, the unsealing member 20 is provided in the end side of the sealing member 19 with respect to the direction substantially perpendicular to the direction in which the plurality of openings 35a are arranged. The fixing portion includes a fixing portion 16d, necessary for the unsealing, corresponding to the first fixing portion 16d in First Embodiment. When the shape of the developer accommodating member 34 itself is intended to be maintained by the molded portion 34a, the developer accommodating member 34 has the shape following the frame and therefore the developer accommodating member 34 is supported by the frame as a whole, so that the developer accommodating member 34 is not readily moved toward the developer supplying roller 23 and the developing roller 13.

[0236] As a means for fixing the fixing portion, it is possible to use the (heat) welding, the ultrasonic welding, the adhesive bonding, the insertion between the frames, the heat clamping, the ultrasonic clamping, the hooking using the hole and the projection, and the like.

[0237] The constitutions of the sealing member 19 and the unsealing member 20 are the same as those in First Embodiment.

10 <Summary of unsealing of developer bag>

[0238] The unsealing of the developer bag will be described. The fixing portion and the position thereof are the substantially same as those in First Embodiment, and also the force relationship is the same as that in First Embodiment. Therefore, also the unsealing step is the same as that in First Embodiment (Figures 7 and 8).

[0239] In Second Embodiment, the openings 35a are disposed at the molded portion 34a but also the molded portion 34a is flexible similarly as in First Embodiment, so that also the force relationship is the same as that in First Embodiment. Therefore, also in Second Embodiment, the plurality of connecting portions 35b connects the first bonding portion 22a and the second bonding portion 22b with respect to the direction (arrow E direction) in which the unsealing is advanced. For that reason, when the unsealing of

the first bonding portion 22a is ended and the second bonding portion 22b is unsealed, a force for peeling the sealing member 19 from the developer accommodating member 34 can be transmitted. For that reason, the
5 unsealing also at the bonding portion 22b becomes possible.

[0240] Also the developer discharging port after the unsealing is the same as that in First Embodiment. When the sealing member 19 is unsealed from the
10 above-described developer accommodating member 34, first, the openings 35a are disposed at the lower portion of the developer accommodating member 34, and therefore the position of the openings 35a during the unsealing is moved at the same time when the
15 gravitation acts on the openings 35a, so that the developer is discharged. Further, by the vibration or the like of the developer accommodating member 34, the developer in the neighborhood of the openings 35a is discharged. The unsealing member 20 also functions as
20 the urging member 21. Further, the urging member 21 has a rectangular shape in the cross section perpendicular to the rotational axis direction of the urging member 21, and the discharge of the developer is accelerated by the rotation of the urging member 21
25 as described in First Embodiment (Figure 20). The urging member 21 contacts a surface 34f which is the same surface as the surface where the openings 35a of

the developer accommodating member 34 are provided.

The developer accommodating member 34 is constituted by a plurality of surfaces including the surface where the openings 35a of the developer accommodating member
5 34 are provided and another surface connected to the surface via a bent portion 34d.

[0241] By employing such a constitution, in addition to the effect in First Embodiment, the following effects are achieved.

10 (Effect of vacuum molding)

[0242] By forming a part of the developer accommodating member 34 through the vacuum molding, the following effects are obtained.

[0243] As a first effect, the developer accommodating
15 member 34 can be shaped so as to follow the inside shape of the frame. For that reason, in the bag form as described in First Embodiment, it is difficult to dispose the bag until corner portions of the frame, so that a space (spacing) is formed between the developer
20 bag and the first frame 17 and thus fails to constitute an effective developer accommodating space.

[0244] As a second effect, the developer accommodating member 34 can be shaped so as to follow the shape of the frame and therefore can be easily
25 assembled with the frame. This is because there is no need to push the developer accommodating member into the frame during the assembling so that its shape

follows the shape of the frame.

[0245] As a third effect, the developer accommodating member 34 is not readily moved toward the developer supplying roller 23 and the developing roller 13. This is because the developer accommodating member 34 is supported by the frame as a whole since the shape of the developer accommodating member 34 itself is maintained as described above by the vacuum molding and follows the shape of the frame. For that reason, the second fixing portion for preventing the movement of the developer bag toward the developer supplying roller 23 and the developing roller 13 as described in First Embodiment can be omitted.

[0246] Further, as shown in Figure 19, an effect of pushing the surface 34 which is the same surface as the surface where the openings 35a are provided is as follows. The developer accommodating member 34 is constituted by the plurality of surfaces by the vacuum molding. Therefore, the bent portion 34d is present between the surfaces of the portion surfaces. The surfaces of the developer accommodating member 34 are defined by bent portions. A difference in effect between the case where the surface 34f including the openings 35a is urged and the case where a surface 35e which does not include the openings 35a is urged will be described. The surface 34e is connected to the surface 34f including the opening 35a by the bent

portion 34d. A force received by the surface 34e is transmitted via the bent portion 34d. The force is largely attenuated at the bent portion 34d before it reaches the surface 34f including the openings 35a.

5 For that reason, also a force for moving the openings 35a becomes small compared with the case where the surface 34f including the openings 35a is urged directly. For that reason, the action of discharging the developer by moving the openings 35a becomes small.

10 Therefore, when the urging member 21 urges the surface 34f including the openings 35a, the urging member 21 can efficiently improve the discharging property of the inside developer and can prevent stagnation of the developer.

15 [0247] Thus, by the rotation of the urging member 21 of which function is performed by the unsealing member 20, the developer accommodating member 34 is urged so as to be pressed against the second frame 18, so that the developer accommodating member 34 is deformed to
20 change the position of the openings 35 and thus the inside developer is discharged. Further, there are the plurality of openings 35a and therefore the developer is readily discharged more than the case of a single opening. Further, the openings 35a are disposed
25 downward with respect to the direction of gravitation in the attitude during the image formation and therefore the developer is easily discharged.

[Fifth Embodiment]

[0248] As shown in Figure 35, in this embodiment, different from First to Fourth Embodiments, the case where the developer bag 16 and the developer accommodating member 34 as the flexible container are not disposed in the developer accommodating unit will be described. That is, in this embodiment, the case of a developing device in which the flexible container accommodating the developer is not provided but only the developer accommodating container as the frame for accommodating the developer is provided will be described.

[0249] In the developing device in this embodiment, an elastic developer feeding member 41 which is rotatably provided inside the developer accommodating container and which is rotated to feed the developer, and the developing roller 13 as the developer carrying member for carrying and feeding the developer on its surface are provided.

[0250] A positional relationship among the developer feeding member 41 and the developing roller (developer carrying member portion) 13 as the developer carrying member will be described. As shown in (c) of Figure 35, a distance from the rotation center of the developer feeding member 41 to the closest point on the surface of the developing roller 13 is defined as Z , and a maximum length from the rotation center of the

developer feeding member 41 to the free end of the developer feeding member 41 is defined as T. The positional relationship will be described specifically below.

- 5 [0251] In a general process cartridge, as shown in (a) of Figure 35, the developer accommodated in the developer accommodating container as the frame is fed to the neighborhood of the developing roller 13 by the developer feeding member 41 using a flexible sheet. In
- 10 order to downsize the process cartridge, as shown in (b) of Figure 35, in the case of a positional relationship of contact between the developer feeding member 41 and the developing roller 13 (in the case where a relationship between the distance Z and the
- 15 length T satisfy: $Z < T$), the developing roller 13 and the developer feeding member 41 contact each other every time when the free end of the developer feeding member 41 approaches the developing roller 13. In this case, a coating state of the developer on the
- 20 developing roller 13 is disturbed by the contact of the developer feeding member 41 with the developing roller 13, so that the disturbed portion is recognized as image non-uniformity when the image is outputted by the image forming apparatus.
- 25 [0252] Therefore, in this embodiment, as shown in (d) of Figure 35, a shielding member 42 for preventing the contact between the developer feeding member 41 and

the developing roller 13 is provided between the rotation center of the developer feeding member 41 and the surface of the developing roller 13 (or the neighborhood of these members). As a result, it becomes possible to downsize the process cartridge while preventing contact between the developing roller 13 and the developer feeding member 41. In the case where the shielding member 42 is present between the developing roller 13 and a rotation shaft 40 of the developer feeding member 41, every time when the developer feeding member 41 approaches the developing roller 13, the free end of the developer feeding member 41 is bent and curved by the shielding member 42 and is configured to be in non-contact with the developing roller 13.

[0253] Further, the shielding member 42 is constituted to prevent the passing of the developer feeding member 41 but is constituted to positively permit the passing of the developer similarly as First to Fourth Embodiments. Further, the case where as the developer carrying member, the developer supplying roller (developer feeding member) 23 is present in addition to the developing roller (developer carrying member portion) 13 is shown in (e) of Figure 35. As shown in (e) of Figure 35, also in the case where the developer supplying roller 23 is present, by the presence of the shielding member 42 between the

developer supplying roller 23 and the rotation shaft of the developer feeding member 41, it is possible to prevent contact between these members. Incidentally, also in a constitution shown in (e) of Figure 35, 5 similarly as in the case of the developing roller 13, a distance from the rotation center of the developer feeding member 41 to the closest point on the surface of the developer supplying roller 23 is defined as Z, and a maximum length from the rotation center of the 10 developer feeding member 41 to the free end of the developer feeding member 41 is defined as T.

[Sixth Embodiment]

[0254] In this embodiment, a diffusing means of the developer discharged from a developer bag 16 will be 15 described. In the following, a "longitudinal" means a longitudinal direction of the developer accommodating unit 25 unless otherwise specified. Similarly, a "width" means a length of the 35a, the connecting portion 35b and the like with respect to the 20 longitudinal direction unless otherwise specified.

Further, a downstream-side longitudinal position of each of the opening 35a and the connecting portion 35b with respect to a developer discharging direction (arrow I direction) is referred to as an "immediately 25 downstream (below) (position)" of each of the opening 35a and the connecting portion 35b.

[0255] As shown in Figure 41, the discharging portion

35 includes a plurality of openings 35a along the longitudinal direction (arrow F direction), and the connecting portion 35b is present between adjacent two openings 35a. The developer in the developer bag 16 is discharged through the openings 35a and therefore non-uniformity of a developer supply (free end) amount is locally generated between an immediately downstream position of the opening 35a and an immediately downstream position of the connecting portion 35b. For this reason, immediately after the developer bag 16 is unsealed, the amount of the developer supplied to a portion, corresponding to the immediately downstream position of the connecting portion 35b, of the developing roller 13 becomes locally insufficient, so that there is a possibility that a vertical band-like white dropout image is generated.

[0256] The nonuniformity of the developer supply is alleviated by shortening the width of each connecting portion 35b and decreasing the number of the connecting portions 25b. However, as described above, when each connecting portion 35b is excessively thin (narrow), the developer bag 16 cannot obtain strength such that it can withstand a force at the time of the unsealing. For that reason, as a condition required for the connecting portions, there is a need to provide a thickness and the number (of the connecting portions) to some extent. Further, the developer is

successively discharged from the developer bag 16 and therefore the developer is gradually accumulated in the developer accommodating unit, so that the developer is diffused to some extent in the longitudinal direction in accordance with angle of repose thereof. However, there arises such an adverse effect that it takes a long time from the unsealing of the developer bag 16 until the image can be formed and thus convenience of a user is impaired.

5

10 [0257] Therefore, in Sixth Embodiment, as shown in Figure 42, in order to quickly supply the developer to also the immediately downstream position of the connecting portions 35b, columnar-like diffusing members 45 were provided immediately downstream of the openings 35a. In this embodiment, each of the diffusing members 45 was provided so as to cross a vertical line passing through an associated opening 35a. The diffusing member 45 as the columnar member is fixed on the second frame 18, described later and shown in Figure 44, as its one end and has another end as a free end. Further, the diffusing member 45 has an inclined surface 45a inclined with respect to the longitudinal direction, and the inclined surface 45a opposes the opening 35a. For that reason, the developer discharged from the opening 35a once strikes the diffusing member 45 and is diffused in a direction (arrow N direction) along the inclined surface 45a. As

15

20

25

a result, the developer can be quickly supplied to also the immediately downstream position of the connecting portion 35b.

[0258] However, on the other hand, the amount of the developer supplied to the immediately downstream position of the diffusing member 45 is decreased by being obstructed by the diffusing member 45. For this reason, the width of the diffusing member 45 may preferably be narrow to the possible extent. Further, as shown in Figure 43, by disposing two or more diffusing members 45 to be close to each other, the developer diffused by a diffusing member 45 is supplied to the immediately downstream position of an adjacent (another) diffusing member 45.

[0259] Further, by adjusting the length of the diffusing member 45 with respect to a projection direction of the diffusing member 45, it is possible to prevent a state in which the developer is not supplied to the immediately downstream position of the diffusing member 45. This will be described with reference to Figure 44. Of the opening 35a, a portion located at the closest position to the second frame 18 on which one end of the diffusing member 45 is fixed is referred to as a closest portion 35a1, and a portion located at the remotest position from the second frame 18 is referred to as a remotest portion 35a2. As described above, the developer bag 16 has

flexibility and therefore the position of the opening 35a is changed during the unsealing, so that, it is possible to prevent stagnation of the developer in the neighborhood of the opening 35a. Further, as described above, the developer bag 16 is urged by the urging member (not shown) and therefore the developer is readily discharged in an arrow I direction. Thus, in the case where a state in which flowability of the developer is relatively high and the developer is vigorously discharged from the opening 35a is assumed, the developer is discharged in a region ranging from a downstream side (chain line I1) of the closest portion 35a1 to a downstream side (chain line I2) of the remotest portion 35a2 with respect to a developer discharging direction (arrow I direction).

[0260] From the above, by providing the diffusing member 45 in the region defined by the chain lines I1 and I2, it is possible to diffuse the developer discharged from the opening 35a. One end of the diffusing member 45 is fixed on the second frame 18 and another end of the diffusing member 45 is the free end. Further, an arrow W1 shows a direction in which the projection direction of the diffusing member 45 is viewed from the inside of the developer accommodating unit 25, and an arrow W2 shows a direction perpendicular to the arrow W1 direction.

[0261] Therefore, the diffusing member 45 is set so

that the free end of the diffusing member 45 is located in the region defined by the chain lines I1 and I2. In this embodiment, the diffusing member 45 was set so that the free end of the diffusing member 5 45 crossed the vertical line passing through the opening 35a. At this time, at a portion of the diffusing member 45 ranging from the free end of the diffusing member 45 to the chain line I1, the developer discharged from the opening 35a is diffused 10 by the diffusing member 45. On the other hand, at a portion of the diffusing member 45 ranging from the free end to the chain line I2, the developer discharged from the opening 35a is discharged as it is in the discharging direction (arrow I direction) 15 without striking the diffusing member 45. That is, of the developer discharged from the opening 35a, only a part strikes the diffusing member 45 to be diffused, and a remaining part is discharged it is without striking the diffusing member 45. Each of the 20 developing roller 13 and the developer supplying roller 23 is a rotatable member and therefore the non-uniformity of the developer supply amount with respect to a circumferential direction of each roller is uniformized by a rotating operation of each roller. 25 As a result, the developer can be supplied (fed) to not only the immediately downstream position of the connecting portion 35b but also the immediately

downstream position of the diffusing member 45.

[0262] However, even when the developer is placed in a high-flowability state to the possible extent as described above, the developer is placed in a
5 low-flowability state to some extent, so that it would be also assumed that the developer is discharged in a partly agglomerated state. Also in such a state, as described above, it is desirable that the length of the diffusing member is set so that only a part of the
10 developer discharged from the developer bag 16 is caused to strike the diffusing member 45 to be diffused.

[0263] Then, a constitution of the diffusing member 45 in the case where the low-flowability state of the
15 developer is taken into consideration will be described with reference to Figure 45. In the case where the flowability of the developer is low, when the developer is discharged from the opening 35a, the developer is not discharged vigorously but freely
20 drops in a region ranging from a vertical line (chain line 01) passing through the closest portion 35a1 to a vertical line (chain line 02) passing through the remotest portion 35a2. An arrow O represents the direction of gravitation. In such a case, the free end
25 of the diffusing member 45 may preferably be disposed in the region defined by the chain lines 01 and 02. As a result, only the part of the discharged developer

strikes the diffusing member 45 to be diffused, so that it is possible to supply the developer to also the immediately downstream position of the diffusing member 45. In addition, by employing setting also following a condition of the position of the free end in the high-flowability state of the developer as described above, even when the flowability state of the developer is fluctuated to various states, the developer can be supplied to also the immediately downstream position of the diffusing member 45.

[0264] Then, a positional relation of the diffusing member 45 with the opening 35a and the connecting portion 35b with respect to the longitudinal direction will be described. In Figure 42, there is no large difference in width between the opening 35a and the diffusing member 45, and in the case where the diffusing member 45 is viewed from the arrow W1 direction in Figure 44, the diffusing member 45 is configured to have two inclined surfaces having the same (symmetrical) shape with respect to the longitudinal direction. In addition, the diffusing member 45 is disposed so that a top portion thereof is located immediately downstream (below) of a center of the opening 35a. As a result, the developer diffused, in the longitudinal direction along the two inclined surfaces 45a of the diffusing member 45 is supplied to the immediately downstream position of the adjacent

connecting portions 35b.

[0265] On the other hand, as shown in Figure 46, in the case where the width of the opening 35a is wider than the width of the diffusing member 45 to some extent or more, the diffusing member 45 may preferably be disposed immediately downstream of the opening 35a at a position closer to the adjacent connecting portion 35b. Further, in this case, the diffusing member 45 may only be required to diffuse the developer in only a side closer to the immediately downstream position of the connecting portion 35b, so that there is no need to provide the diffusing member 45 with the two inclined surfaces 45a in order to diffuse the developer in the longitudinal direction. For that reason, the diffusing member 45 may have an almost triangular, shape as shown in Figure 47 and a flat plate-like shape as shown in Figure 48. Further, when the diffusing member 45 has the inclined surface 45a, at the immediately downstream position of the connecting portion 35b, for permitting the supply of the developer, the shape of the diffusing member 45 is not limited to those described above but may also be changed to various shapes.

[0266] Further, in the case where the state in which the flowability of the developer is low and thus the developer is not readily diffused is taken into consideration as described above, the diffusing member

45 may preferably be disposed as shown in (a) and (b) of Figure 49. With respect to the diffusing member 45 and the opening 35a, the case where these are viewed from the arrow W1 direction in Figure 44 is shown in (a) of Figure 49, and the case where these are viewed from the arrow W2 direction in Figure 44 is shown in (b) of Figure 49. With respect to broken lines F1 to F5, in (a) and (b) of Figure 49, each of the same broken lines represents the same longitudinal position.

10 In the form shown in Figure 49, in order to receive the developer discharged from the opening 35a, a part of the inclined surface 45a was disposed at the immediately downstream position of the opening 35a. On the other hand, a lower end 45b of the inclined surface 45a was disposed at the immediately downstream position of the connecting portion 35b. In this embodiment, the diffusing member 45 was provided so that the lower end 45b of the inclined surface 45a crossed a vertical line passing through the connecting portion 35b. In this case, of the inclined surface 45a, at a portion (first inclined surface portion) located at the immediately downstream position of the opening 35a, the developer discharged from the opening 35a directly strikes the diffusing member 45. On the other hand, of the inclined surface 45a, at a portion (second inclined surface portion) located at the immediately downstream position of the connecting

portion 35b, the developer discharged from the opening 35a does not strike the diffusing member 45 directly. However, the developer discharged from the opening 35a strikes a point P1 on the first inclined surface portion and moves in a direction (arrow N direction) along the inclined surface 45a. For that reason, the developer is supplied to also a point P2 at the lower end 45b of the inclined surface portion constituting the second inclined surface portion where the developer discharged from the opening 35a does not strike the diffusing member 45. Thereafter, the developer drops from the point P2 in the direction of gravitation (arrow O direction), so that the developer can be supplied to also the immediately downstream position of the connecting portion 35b.

[0267] However, in the case of the constitution shown in Figure 49, the developer diffused by the diffusing member 45 is supplied to only one longitudinal position of longitudinal positions immediately below the connecting portion 35b. Therefore, a constitution for uniformly supply the developer to several immediately downstream positions of the connecting portion 35b is shown in (a) and (b) of Figure 50. Similarly as in (a) and (b) of Figure 49, the case where the diffusing member 45 and the opening 35a are viewed from the arrow W1 direction in Figure 44 is shown in (a) of Figure 50, and the case where these

are viewed from the arrow W2 direction in Figure 44 is shown in (b) of Figure 50. Similarly, with respect to broken lines F1 to F9, in (a) and (b) of Figure 50, each of the same broken lines represents the same
5 longitudinal position. In the constitution in Figure 50, the diffusing member 45 has a plurality of inclined surfaces 45a, and an inclination angle of the inclined surface 45a becomes steeper at a position closer to the end of the diffusing member 45. For that
10 reason, the width of the diffusing member 45 becomes narrower at the position closer to the end of the diffusing member 45, so that the longitudinal position of the lower end 45b of the inclined surface 45a approaches the longitudinal position of an upper end
15 45c of the diffusing member 45. Thus, the diffusing member 45 has the inclined surface 45a as a changing portion where the width of the diffusing member 45 with respect to the longitudinal direction of the frame is changed depending on the position. Similarly
20 as in the constitution in Figure 49, the developer discharged from the opening 35a drops on the point P1 of the inclined surface 45a and thereafter moves in the direction (arrow N direction) along the inclined surface 45a, so that the developer drops from the
25 lower end point P2 of the inclined surface 45a in the direction of gravitation (arrow O direction). Further, with respect to the developer dropping on a point P3

of the inclined surface 45a other than the inclined surface 45a including the point P1, the developer drops from a point P4 at the longitudinal position other than the longitudinal position of the point P2. Thus, in the constitution in Figure 50, the plurality of inclined surfaces 45a are provided and are configured to have associated lower ends 45b different in longitudinal direction, so that the developer can be supplied to several longitudinal positions by a single diffusing member.

[0268] In addition, similarly, as the diffusing member 45 for supplying the developer to several longitudinal positions, another constitution is shown in Figure 51. Similarly as in Figures 49 and 50, the case where the diffusing member 45 and the opening 35a are viewed from the arrow W1 direction in Figure 44 is shown in (a) of Figure 51, and the case where these are viewed from the arrow W2 direction in Figure 44 is shown in (b) of Figure 51. Similarly, with respect to broken lines F1 to F8, in (a) and (b) of Figure 51, each of the same broken lines represents the same longitudinal position. In the constitutions in Figures 49 and 50, each of the inclined surfaces 45a as the changing portion was the surface parallel to the arrow W1 direction in Figure 44 and therefore one inclined surface 45a has the lower end 45b at only one longitudinal position. On the other hand, in the

constitution in Figure 51, the inclined surface 45a as the changing portion was not the surface parallel to the arrow W1 direction in Figure 44 but has a lower end 45b which has a width with respect to the longitudinal direction to some extent. For example, the developer dropping on the point P1 of the inclined surface 45a moves in the direction (arrow N direction) along the inclined surface 45a, so that the developer drops from the lower end point P2 of the inclined surface 45a in the direction of gravitation (arrow O direction). On the other hand, the developer dropping on another point P3 of the inclined surface 45a including also the point P1 drops from a point P4 at the longitudinal position other than the longitudinal position of the point P2. Thus, when the drop positions of the developer discharged from the developer bag 16 are different from each other, the longitudinal positions of the points on the inclined surface lower ends to which the developer is moved along the inclined surface 45a are also different from each other, so that the developer can be supplied further uniformly.

[0269] Further, as the diffusing member 45 for supplying the developer to several longitudinal positions, another constitution is shown in (a) and (b) of Figure 52. Also with respect to the constitution in (a) and (b) of Figure 52, the case

where the diffusing member 45 and the opening 35a are viewed from the arrow W1 direction in Figure 44 is shown in (a) of Figure 52, and the case where these are viewed from the arrow W2 direction in Figure 44 is shown in (b) of Figure 52. Similarly, with respect to broken lines F1 to F8, in (a) and (b) of Figure 52, each of the same broken lines represents the same longitudinal position. In the constitution in Figure 52, the length of the diffusing member 45 with respect to the direction of gravitation (arrow O direction) is made shorter with a position closer to the end of the diffusing member 45. Even when the changing portion of the diffusing member 45 is configured in such a manner, similarly as in the constitution of Figure 51, the lower end 45b of the inclined surface 45a has a shape such that it has a width with respect to the longitudinal direction, so that the developer can be supplied to the several longitudinal positions.

[0270] Incidentally, the shape of the diffusing member 45 for supplying the developer to the immediately downstream position of the connecting portion 35b is not limited to those in the constitutions shown in Figures 49 to 52 but may also be changed to various shapes.

[Seventh Embodiment]

[0271] The diffusing member 45 described in Sixth Embodiment may also be a separate member from the

shielding member 42 for preventing the contact of the sealing member 19 with the developer supplying roller 23 as described in First to Fifth Embodiments. In this case, similarly as in First to Fifth Embodiments, the
5 shielding member 42 is configured to positively permit the passing of the developer.

[0272] Further, on the other hand, the diffusing member 45 may also have the function as the shielding member 42 for preventing the contact of the sealing
10 member 19 with the developer supplying roller 23. In such a case, there is a need to satisfy both of the arrangements and the shapes of the shielding member 42 and the diffusing member 45 as described in the above-described embodiments. As the function of the
15 shielding member 42 for preventing the sealing member 19 from contacting the developer supplying roller 23, the shielding member 42 is required to have the length with respect to the projection direction to some extent or more. On the other hand, in order to supply
20 the developer to also the immediately downstream position of the diffusing member 45, the length of the diffusing member 45 with respect to the projection direction may preferably be short to some extent. In this case, as shown in Figure 54, of the diffusing
25 member 54, only a part thereof ranging from the immediately downstream position of the opening 35a to the free end thereof may only be required to

constitute a non-diffusing portion 46 having a width and a shape to the extent not impairing the developer supply. As a result, it is possible to supply the developer to the immediately downstream position of the diffusing member 45 while preventing the contact of the sealing member 19 with the developer supplying roller 23.

[Eighth Embodiment]

[0273] In Sixth and Seventh Embodiments, the case where one end of the diffusing member 45 is fixed on the Second frame 18 and another end is the free end was described. However, there is no need that another end is not necessarily be the free end, and as shown in Figure 55, the diffusing member 45 may also have a beam-like shape such that another end thereof is fixed on the first frame 17. Thus, by providing the beam-like member in the frames, the strength of the developer accommodating unit 25 can be enhanced, so that the developer accommodating unit 25 can be made less deformable. Further, by fixing the diffusing member 45 at its both ends, stress acting on the diffusing member 45 can be dispersed toward the both ends, so that also the strength of the diffusing member 45 itself can be enhanced. Also in such a case, the developer discharged from the developer bag 16 is diffused by the diffusing member 45, so that the developer can be quickly supplied to the immediately

downstream position of the connecting portion 35b.

[0274] In addition, as shown in Figure 56, the portion fixed on the first frame may also be the non-diffusing portion 46.

5 [0275] Further, as shown in (a) and (b) of Figure 57, a crossing-linking member (connecting member) 47 for connecting a plurality of diffusing members 45 may also be provided at free ends of the diffusing members 45. Part (b) of Figure 57 is a schematic view as seen
10 from an arrow W2 direction in (a) of Figure 57. Also in the case where the cross-linking member 47 is provided, the strength of the diffusing members 45 can be enhanced. Similarly, as shown in (a) and (b) of Figure 58, each of a plurality of diffusing members 45
15 has a non-diffusing portion 46, and the non-diffusing portions 46 may be connected by a cross-linking member 47. Part (b) of Figure 58 is a schematic view as seen from an arrow W2 direction in (a) of Figure 58.

[0276] In the above-described embodiments, as the
20 process cartridge detachably mountable to the image forming main assembly, a process cartridge integrally including the photosensitive drum and, as process means acting on the photosensitive drum, the charging means, the developing means and the cleaning means was
25 exemplified. However, the process cartridge is not limited thereto. For example, the process cartridge including, in addition to the photosensitive drum,

either one of the charging means, the developing means and the cleaning means may also be used.

[0277] Further, in the above-described embodiments, the constitution in which the process cartridge including the photosensitive drum is detachably mountable to the image forming apparatus main assembly is exemplified but the present invention is not limited thereto. For example, an image forming apparatus in which the respective constituent elements are incorporated and an image forming apparatus to which each of the constituent elements is detachably mounted may also be used.

[0278] Further, in the above-described embodiments, the printer is exemplified as the image forming apparatus but the present invention is not limited thereto. For example, other image forming apparatuses such as a copying machine, a facsimile machine, a multi-function machine having a combined function of these machines, and the like machine may also be used.

A similar effect can be obtained by applying the present invention to these image forming apparatuses.

[0279] While the invention has been described with reference to the structures disclosed herein, it is not confined to the details set forth and this application is intended to cover such modifications or changes as may come within the purpose of the improvements or the scope of the following claims.

[INDUSTRIAL APPLICABILITY]

[0280] According to the present invention, it is possible to provide a developing device capable of downsizing a process cartridge while preventing
5 contact between a developer feeding member and a developing roller.

INTELLECTUAL PROPERTY OFFICE
RECEIVED
2017 MAY 12 PM 4:09

CLAIMS

1. A developing device comprising:
- 5 a flexible container for accommodating developer,
said flexible container provided with an opening for
permitting discharge of the developer;
- a frame for accommodating said flexible container
and for accommodating the developer discharged from
said flexible container;
- 10 an urging member, rotatably provided inside said
frame, for urging said flexible container by rotation
thereof to deform said flexible container; and
- a developer carrying member for carrying the
developer on its surface, wherein a distance X from a
15 rotation center of said urging member to said surface
of said developer carrying member is less than a
distance T from the rotation center of said urging
member to a free end of said urging member for urging
said flexible container, and
- 20 wherein a shielding member for preventing contact
of said urging member with said developer carrying
member is provided between the rotation center of said
urging member and said surface of said developer
carrying member.
- 25 2. A developing device according to claim 1,
wherein said developer carrying member is one of (i) a
developer carrying member for feeding the developer to

05/15/2017 13:45 00359

06/09/2018 10:01 04707

a developing portion that opposes an
electrophotographic photosensitive member while
carrying the developer on its surface and (ii) a
developer supplying member for removing from another
5 developer carrying member the developer remaining at a
developing portion after development and for supplying
a fresh developer to another developer carrying member,
and

wherein said shielding member prevents said
10 urging member from contacting said developer carrying
member or said developer supplying member.

3. A developing device according to claim 1,
wherein said shielding member includes a plurality of
15 shielding portions for preventing contact of said
urging member with said developer carrying member, and

wherein said plurality of shielding portions is
provided at predetermined intervals for permitting
discharge of the developer.

20

4. A developing device according to claim 1,
wherein said urging member includes:

a shaft portion rotatably provided in said frame;
a first urging member, wherein said first urging
25 member (i) is mounted to said shaft portion, (ii) has
elasticity, and (iii) satisfies the relationship of X
<T, and

05/15/2017 13:45 00360

06/09/2018 10:01 04708

wherein said free end of said urging member is a free end of said first urging member; and

a second urging member that is mounted to said shaft portion, wherein a distance Y from the rotation center to a free end of said second urging member is shorter than the distance T of said first urging member and satisfies the relationship of $X > Y$, and

wherein said second urging member includes a notch portion or a cut away portion at a position where said second urging member contacts said shielding member.

5. A developing device according to claim 4, wherein said first urging member is a sealing member for sealing the opening of said flexible container, and wherein said sealing member is wound up by rotation of said shaft portion to unseal the opening.

6. A developing device according to claim 1, wherein said urging member urges said flexible container against said frame.

7. A developing device according to claim 1, wherein said urging member changes a position of the opening of said flexible container by urging said flexible container.

05/15/2017 13:45 00361

06/09/2018 10:01 04709

8. A developing device according to claim 1, wherein said flexible container is provided with a plurality of openings.

5 9. A developing device according to claim 1, wherein said flexible container has a shape including a plurality of surfaces between which a bent portion is interposed, and wherein said urging member urges a surface where the opening of said flexible container
10 exists.

10. A developing device according to claim 1, wherein said flexible container is provided so that the opening thereof is open into a downward direction
15 of the gravitation direction during image formation.

11. A developing device according to claim 1, wherein said urging member is a stirring member for stirring the developer, inside said frame, discharged
20 from said flexible container.

12. A developing device according to claim 1, wherein said shielding member includes a columnar member, and wherein said columnar member crosses a
25 vertical line passing through the opening.

13. A developing device according to claim 12,

wherein said columnar member has at least one inclined surface that opposes the opening and which is inclined with respect to a longitudinal direction of said frame.

5 14. A developing device according to claim 13, wherein said flexible container includes a connecting portion between adjacent openings, and wherein a lower end of said inclined surface crosses a vertical line passing through said connecting portion.

10

15 15. A developing device according to claim 12 wherein said columnar member has an end as a free end that crosses a vertical line passing through the opening.

15

20 16. A developing device according to claim 12, wherein said columnar member is provided at a position where the developer discharged through the opening strikes said columnar member and diffuses the developer discharged through the opening.

25 17. A developing device according to claim 16, wherein said columnar member has at least one inclined surface that opposes the opening and which diffuses the developer in a longitudinal direction of said frame.

05/15/2017 13:45 00363

06/09/2018 10:01 04711

18. A developing device according to claim 17,
wherein said inclined surface includes: a first
inclined surface at which the developer discharged
through the opening strikes; and a second inclined
5 surface at which the developer discharged through the
opening does not strike, wherein the developer that
strikes said first inclined surface is directed toward
said second inclined surface by an inclination of said
inclined surface.

10 19. A developing device according to claim 16,
wherein said columnar member has an end as a free end
provided at a position where the developer discharged
through the opening strikes.

15 20. A developing device according to claim 12,
wherein the opening includes a connecting portion
between itself and an adjacent opening, and wherein a
width of said columnar member with respect to a
longitudinal direction of said frame is narrower than
20 a width of said connecting portion with respect to the
longitudinal direction of said frame.

21. A developing device according to claim 12,
wherein said columnar member includes a changing
25 portion for changing a width thereof, with respect to
the longitudinal direction of said frame, depending on
a position thereof.

22. A developing device according to claim 21, wherein said changing portion is positioned immediately below the opening.

5

23. A developing device according to claim 12, further comprising a cross-linking member, distinct from said frame, for connecting a plurality of adjacent columnar members.

10

24. A developing device according to claim 12, wherein said columnar member (i) is such that a distance X from a rotation center of said urging member to said surface of said developer carrying member and a distance T from the rotation center of said urging member to a free end thereof for urging said flexible container satisfy a relationship of $X < T$ and (ii) is provided between the rotation center of said urging member and said surface of said developer carrying member to prevent contact of said urging member with said developer carrying member.

25. A developing device according to claim 24, wherein said developer carrying member is one of (i) a developer carrying member for feeding the developer to a developing portion that opposes an electrophotographic photosensitive member while

carrying the developer on its surface or (ii) a
developer supplying member for removing from another
developer carrying member the developer remaining at a
developing portion after development and for supplying
5 a fresh developer to said another developer carrying
member, and wherein said columnar member prevents said
urging member from contacting said developer carrying
member or said developer supplying member.

10 26. A developing device according to claim 24,
wherein said urging member includes:

a shaft portion rotatably provided in said frame;
a first urging member;
a second urging member that is mounted to said
15 shaft portion,

wherein said first urging member (i) is mounted
to said shaft portion, (ii) has elasticity, and (iii)
satisfies the relationship of $X < T$, wherein said free
end of said urging member is a free end of said first
20 urging member, and wherein a distance Y from the
rotation center to a free end of said second urging
member is shorter than the distance T of said first
urging member and satisfies a relationship of $X > Y$, and
wherein said second urging member includes a notch
25 portion or a cut away portion at a position where said
second urging member contacts said columnar member.

27. A developing device according to claim 26,
wherein said first urging member is a sealing member
for sealing the opening of said flexible container,
and wherein said sealing member is wound up by
5 rotation of said shaft portion to unseal the opening.

28. A developing device according to claim 24,
wherein said urging member urges said flexible
container against said frame.

10

29. A developing device according to claim 24,
wherein said urging member changes a position of the
opening of said flexible container by urging said
flexible container.

15

30. A developing device according to claim 24,
wherein said flexible container has a shape including
a plurality of surfaces between which a bent portion
is interposed, and wherein said urging member urges a
20 surface where the opening of said flexible container
exists.

31. A developing device according to claim 12,
wherein said flexible container is provided so that
25 the opening thereof is open into a downward direction
of the gravitation direction during image formation.

05/15/2017 13:45 00367

06/09/2018 10:01 04715

32. A developing device according to claim 24,
wherein said urging member is a stirring member for
stirring the developer inside said frame that is
5 discharged from said flexible container.

33. A cartridge detachably mountable to a main
assembly of an image forming apparatus, said cartridge
comprising: an electrophotographic photosensitive
10 member; and a developing device according to claim 1
that is provided integrally with said
electrophotographic photosensitive member.

34. An electrophotographic image forming
15 apparatus comprising a cartridge according to claim 33.

INTELLECTUAL PROPERTY OFFICE
RECEIVED
2017 MAY 12 PM 4:16

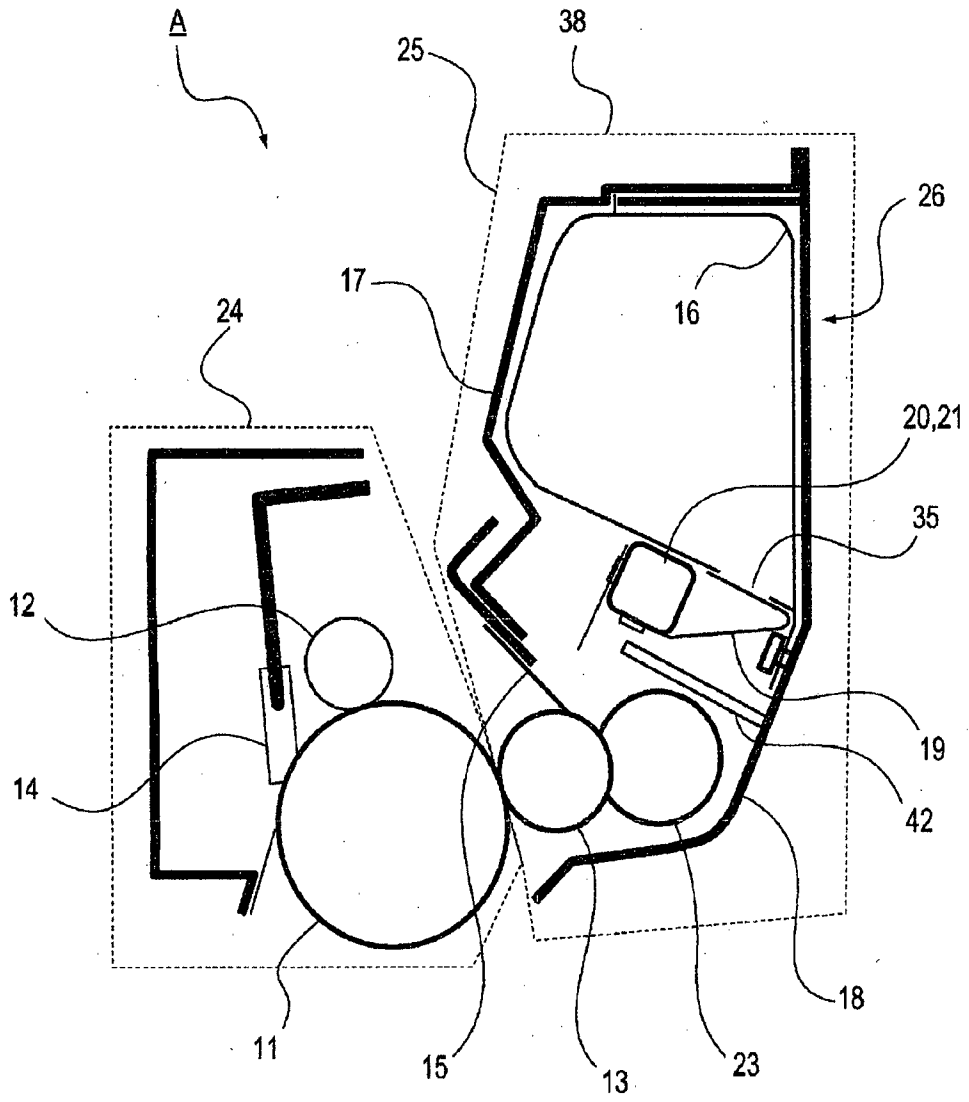

Fig. 1

Canon Kabushiki Kaisha
Applicant

By:

C. RISEL G. CASTILLO-TALEON

06/09/2018 10:01 04718

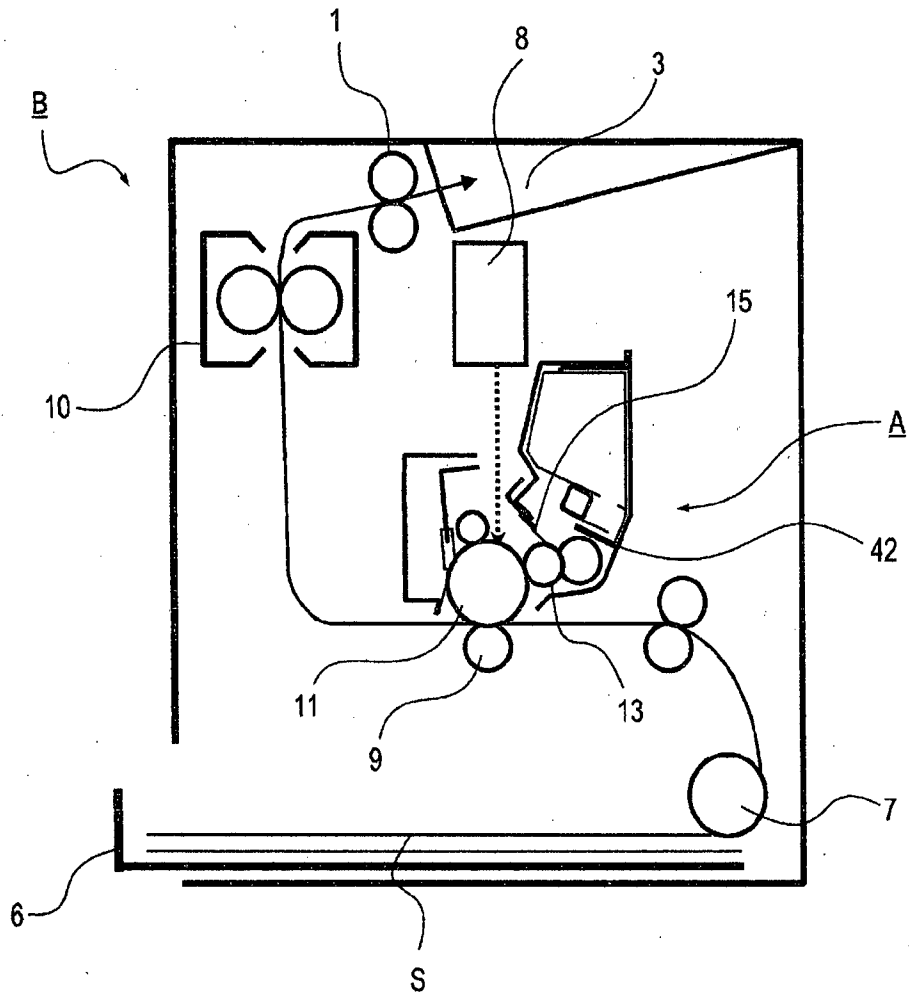

06/09/2018 10:01 04719

Fig. 2

Canon Kabushiki Kaisha
Applicant

By:

[Signature]
C. RISEL G. CASTILLO-TALEON

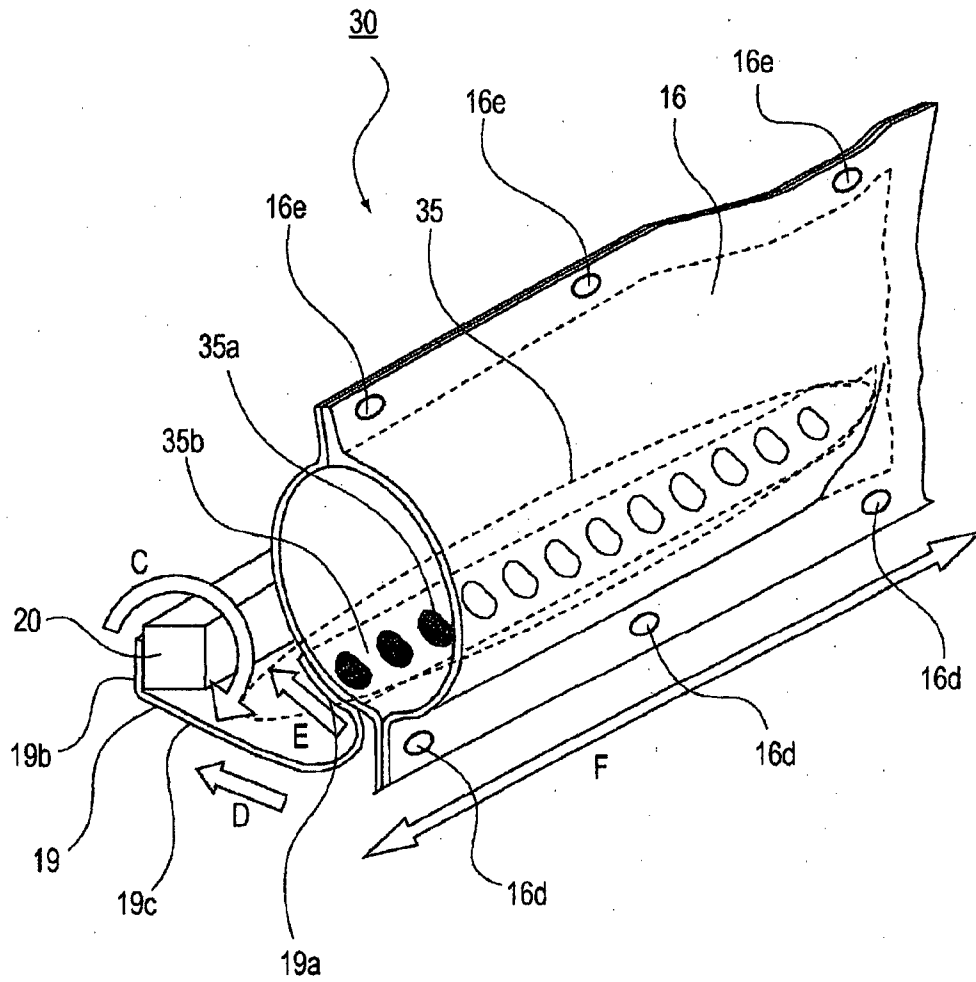

06/09/2018 10:01 04729

Fig. 3

Canon Kabushiki Kaisha
Applicant

By:

C. RISEL G. CASTILLO-TALEON

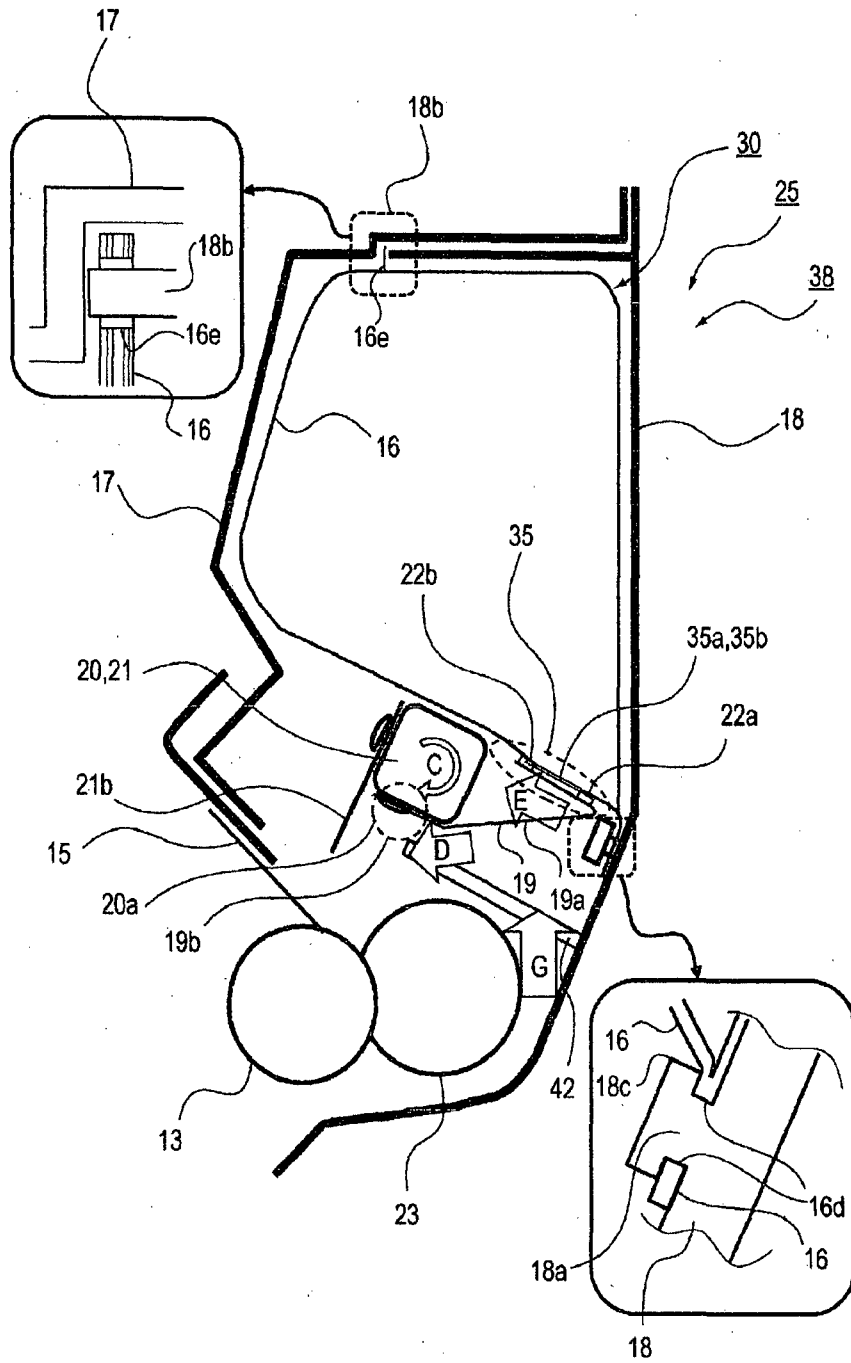

Fig. 4

Canon Kabushiki Kaisha
Applicant

By:

C. RISEL G. CASTILLO-TALEON

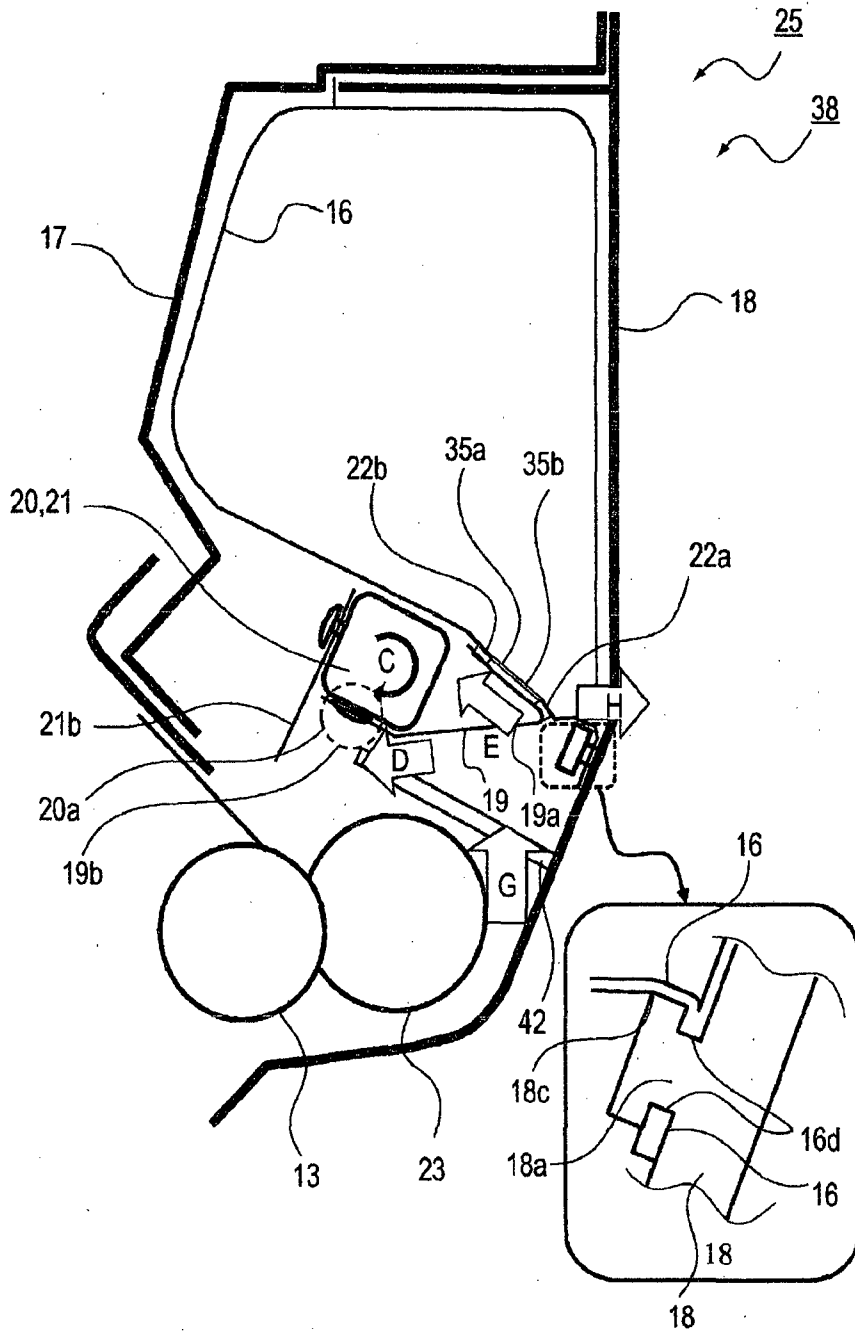

Fig. 5

Canon Kabushiki Kaisha
Applicant

By:

C. RISEL G. CASTILLO-TALEON

06/09/2018 10:01 04722

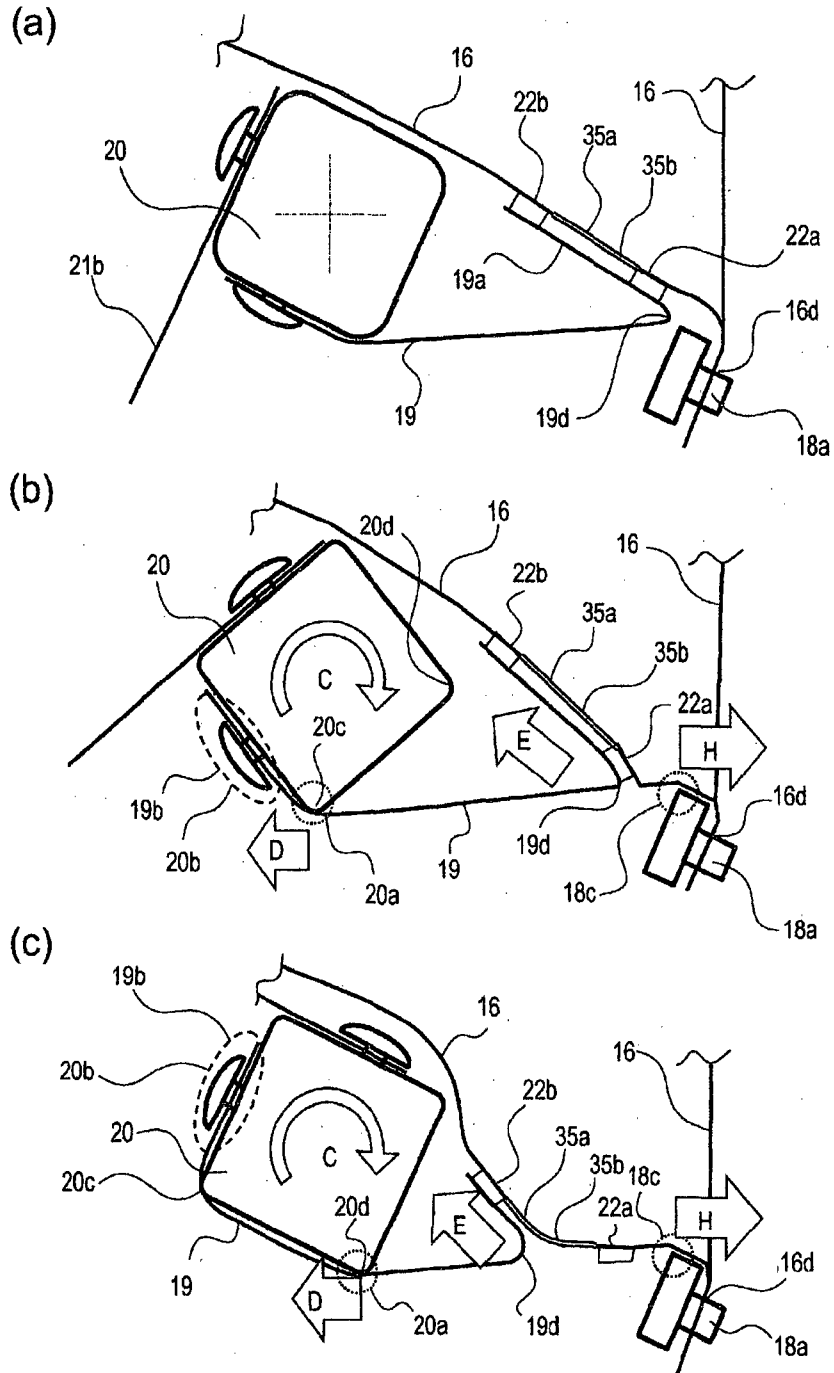

Fig. 7

Canon Kabushiki Kaisha
Applicant

By:

C. RISEL G. CASTILLO-TALEON

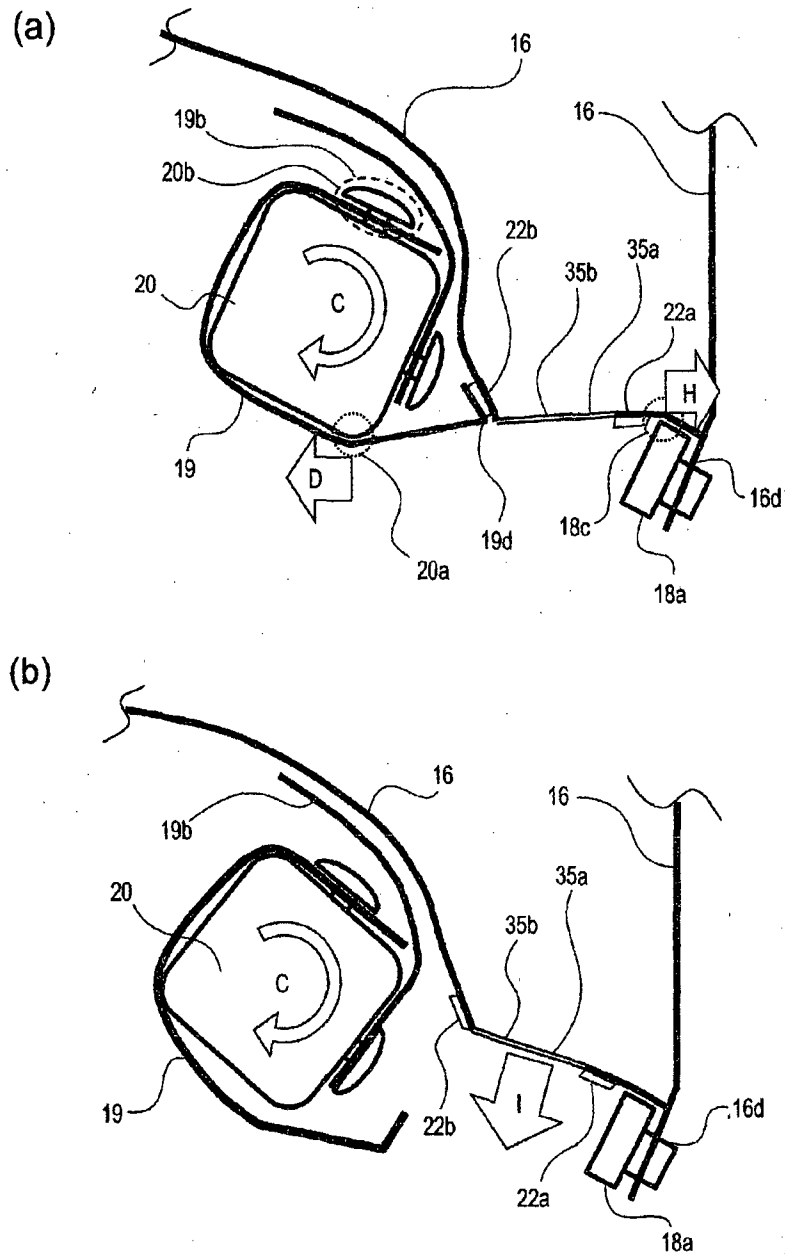

Fig. 8

Canon Kabushiki Kaisha
Applicant

By:

C. RISEL G. CASTILLO-TALEON

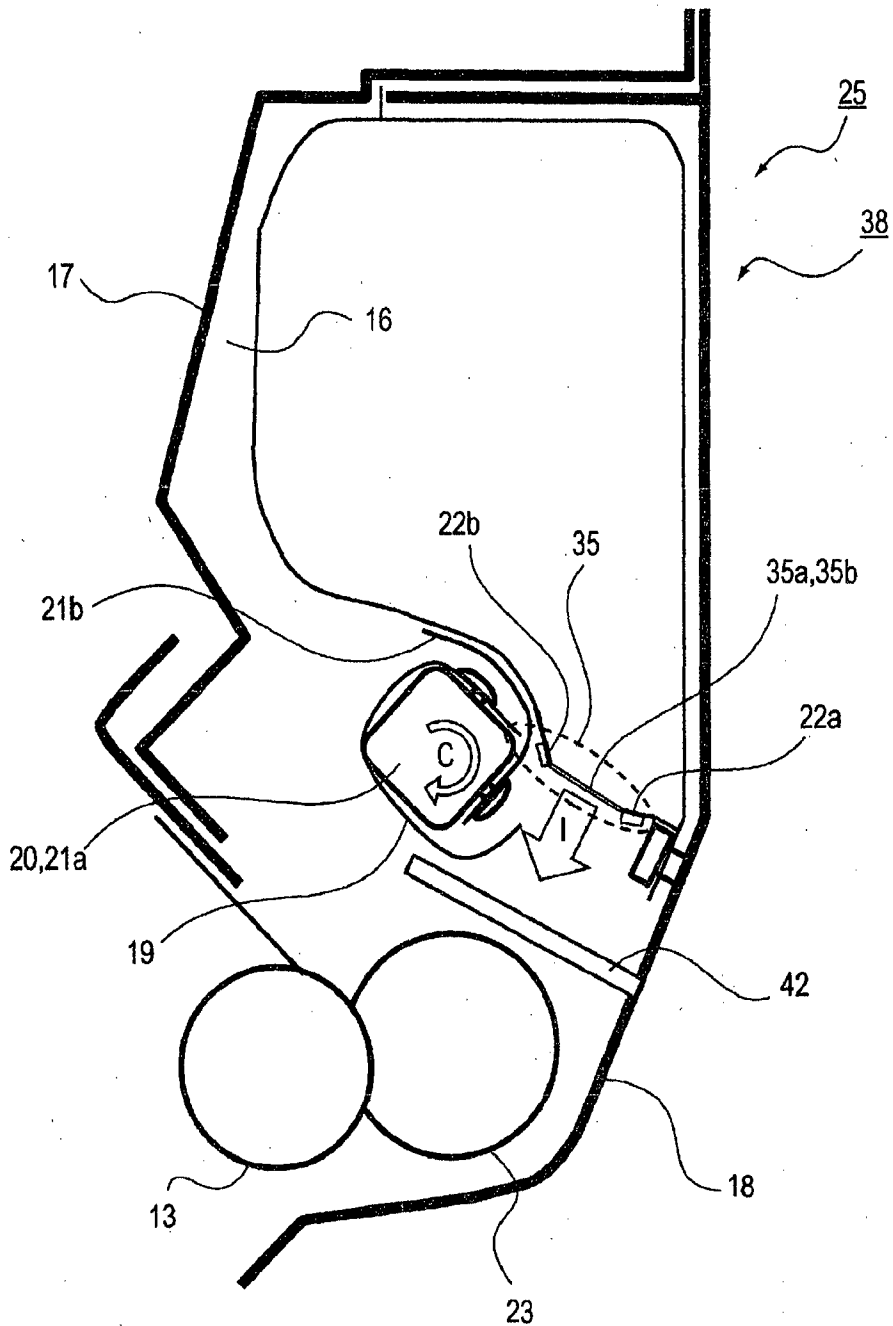

Fig. 9

Canon Kabushiki Kaisha
Applicant

By:

C. RISEL G. CASTILLO-TALEON

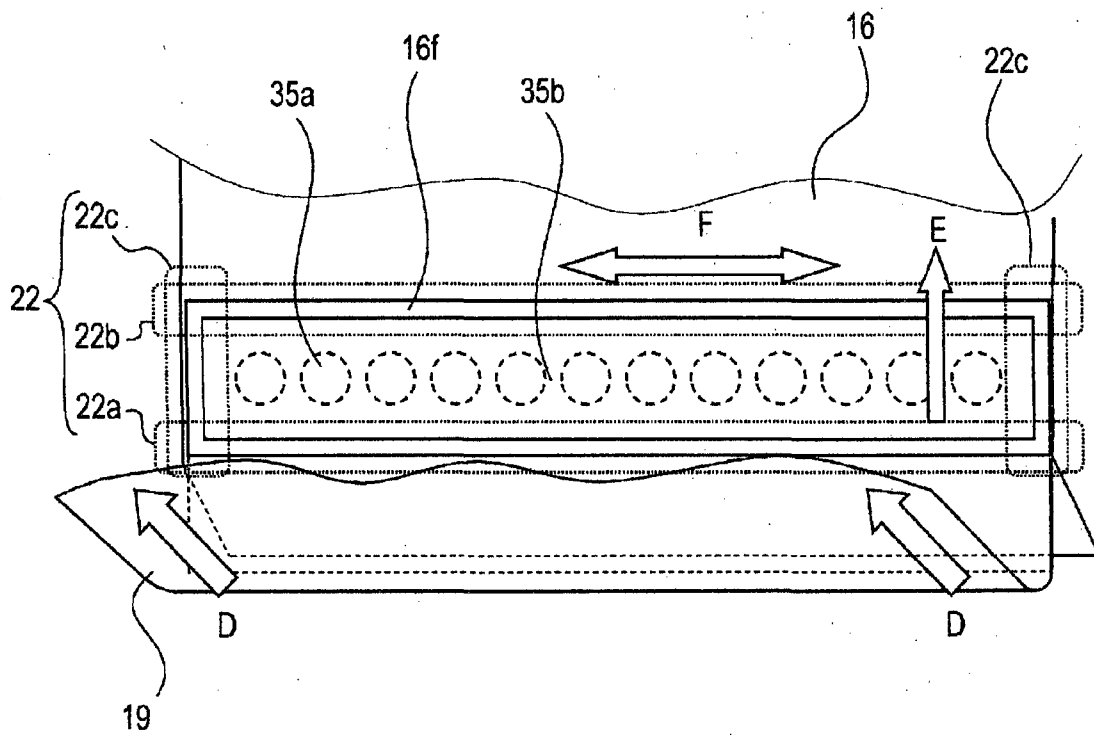

Fig. 10

Canon Kabushiki Kaisha
Applicant

By:

C. RISEL G. CASTILLO-TALEON

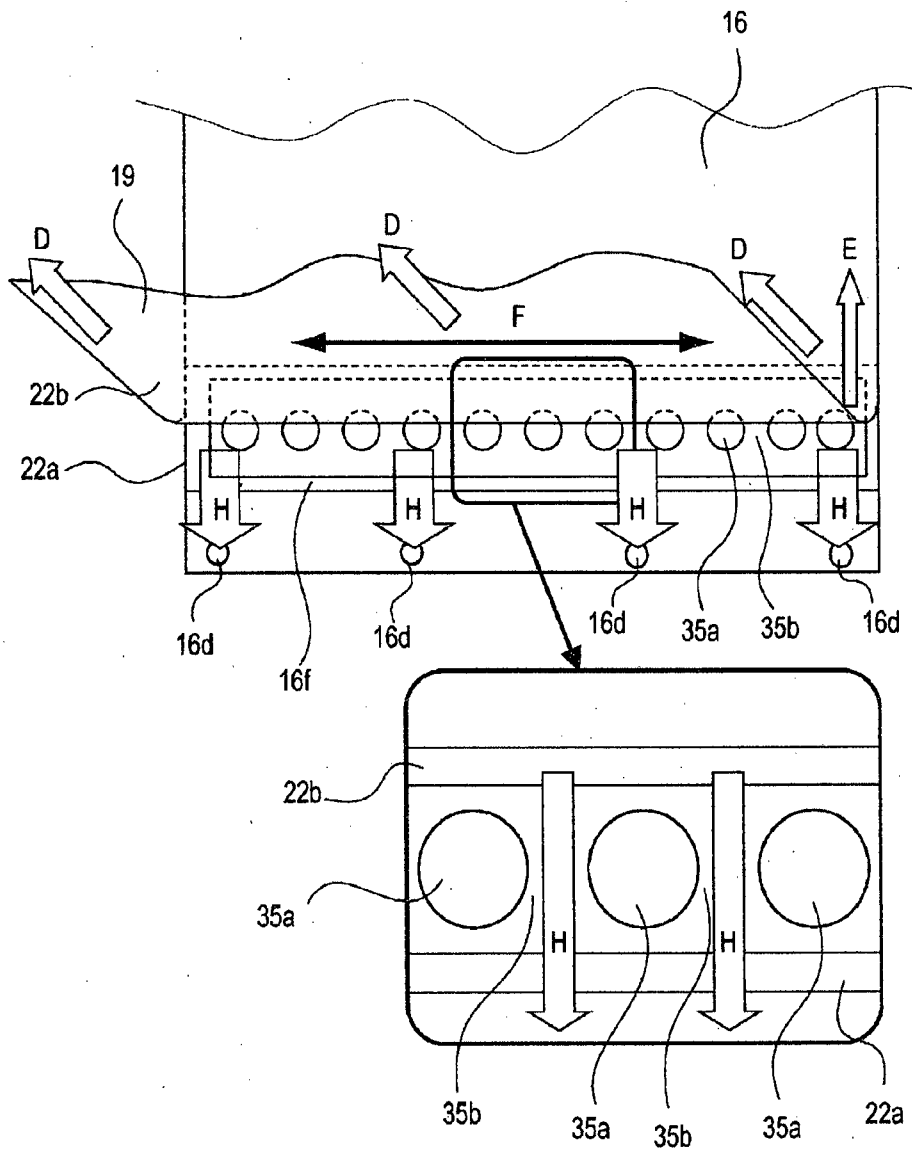

Fig. 11

Canon Kabushiki Kaisha
Applicant

By:

C. RISEL G. CASTILLO-TALEON

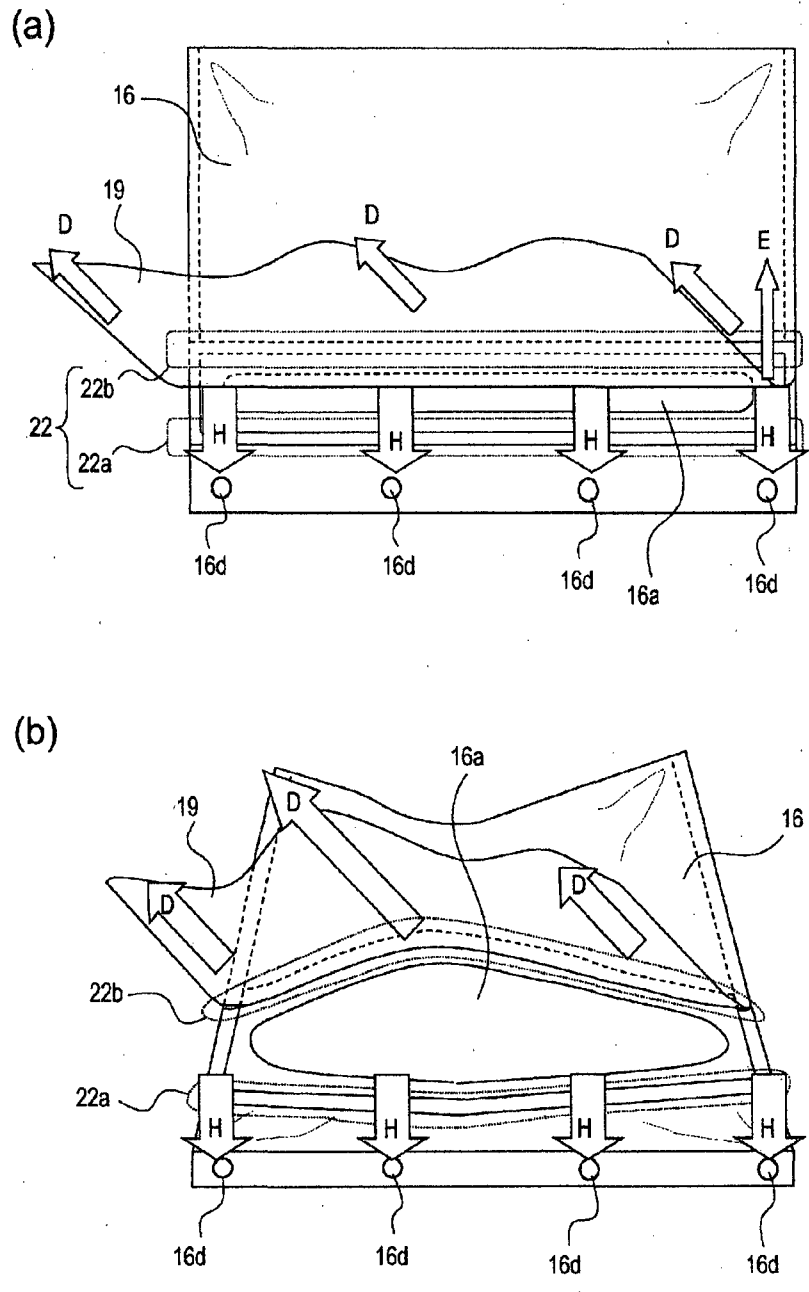

Fig. 13

Canon Kabushiki Kaisha
Applicant

By:

C. RISEL G. CASTILLO-TALEON

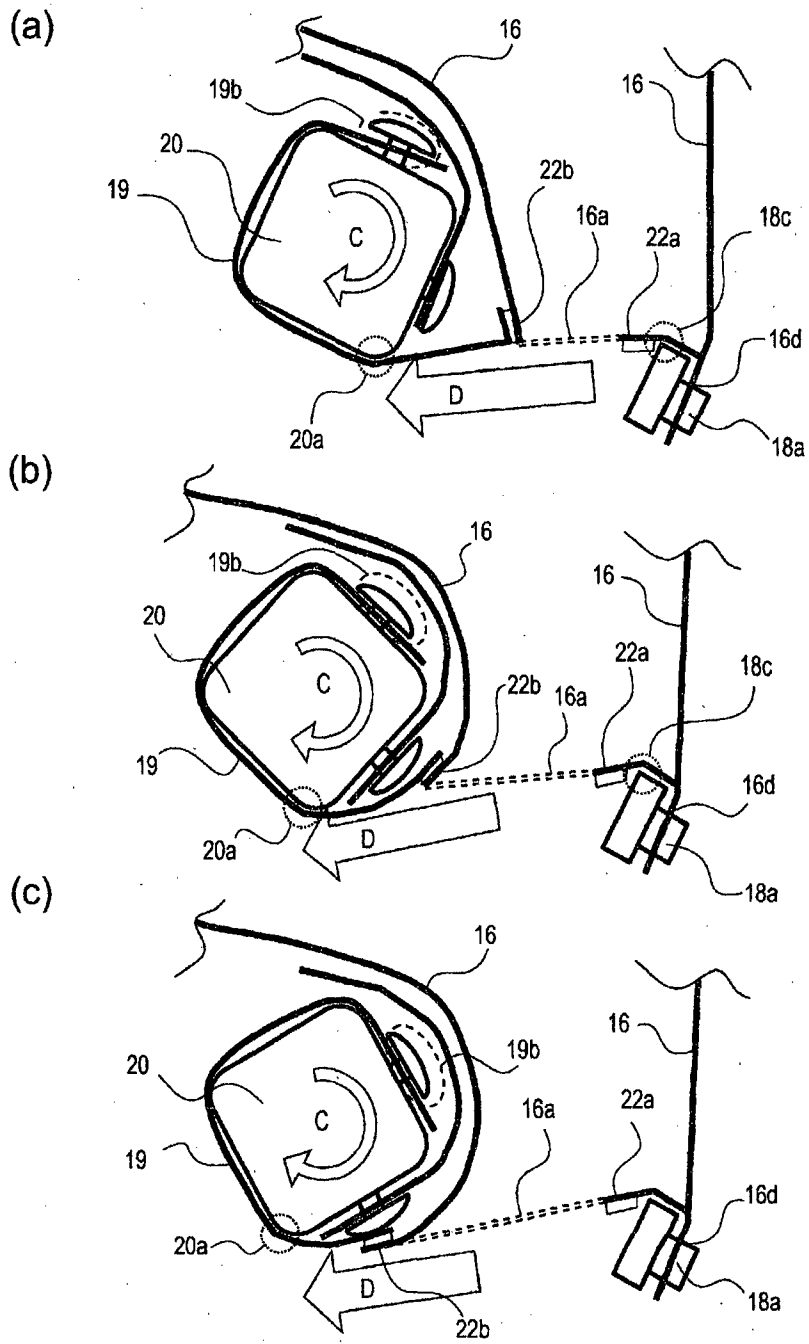

Fig. 14

Canon Kabushiki Kaisha
Applicant

By:

C. RISEL G. CASTILLO-TALEON

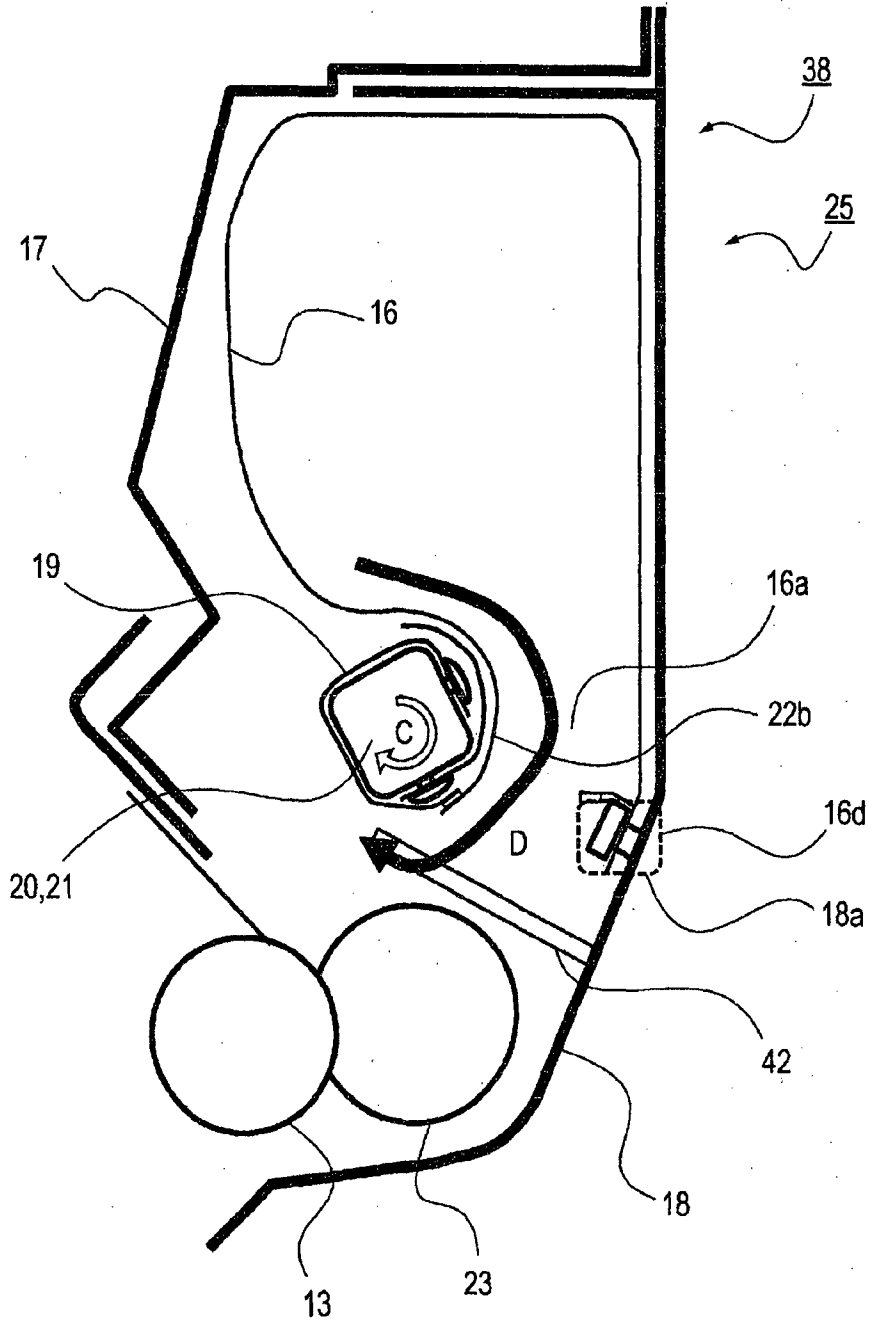

Fig. 15

Canon Kabushiki Kaisha
Applicant

By:

C. RISEL G. CASTILLO-TALEON

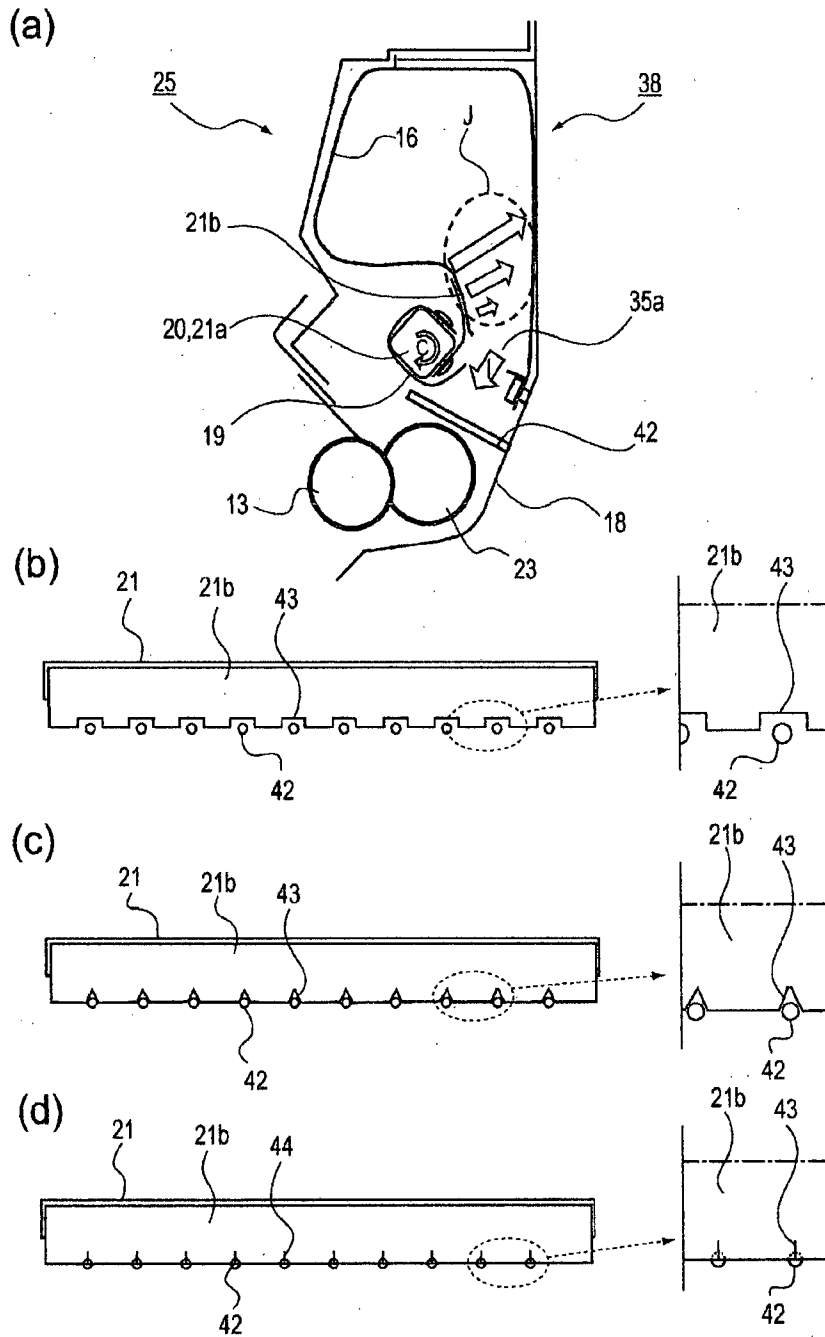

Fig. 16

Canon Kabushiki Kaisha
Applicant

By:

C. RISEL G. CASTILLO-TALEON

06/09/2018 10:02 04734

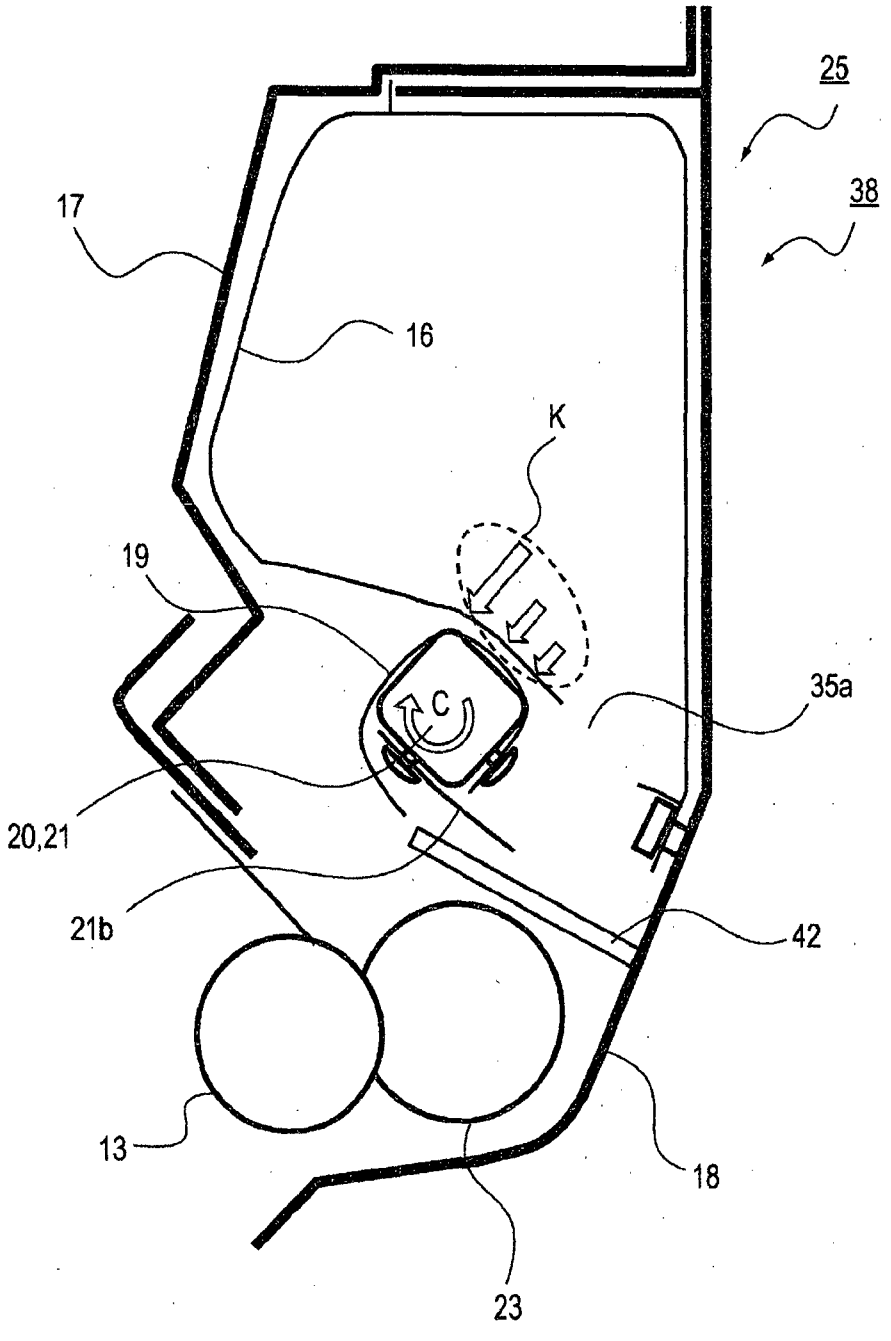

Fig. 17

Canon Kabushiki Kaisha
Applicant

By:

C. RISEL G. CASTILLO-TALEON

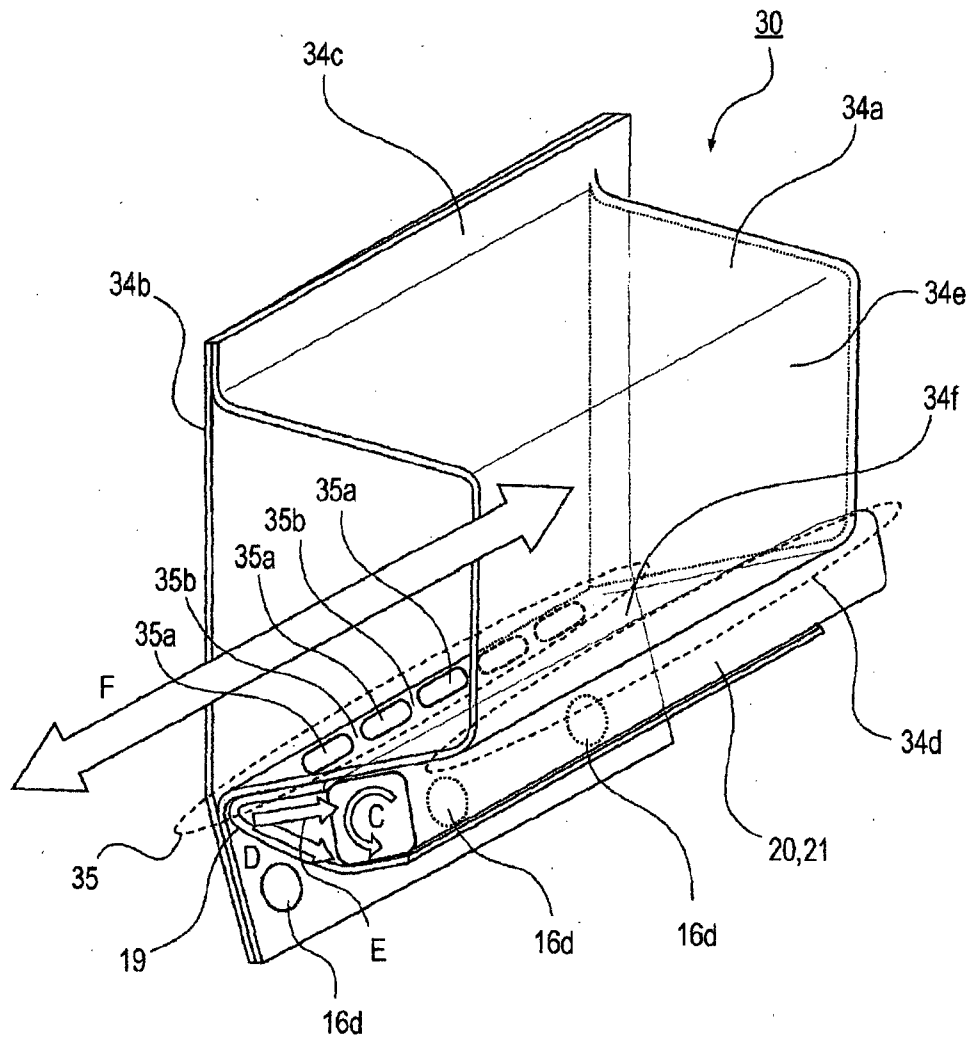

Fig. 18

Canon Kabushiki Kaisha
Applicant

By:

[Signature]
C. RISEL G. CASTILLO-TALEON

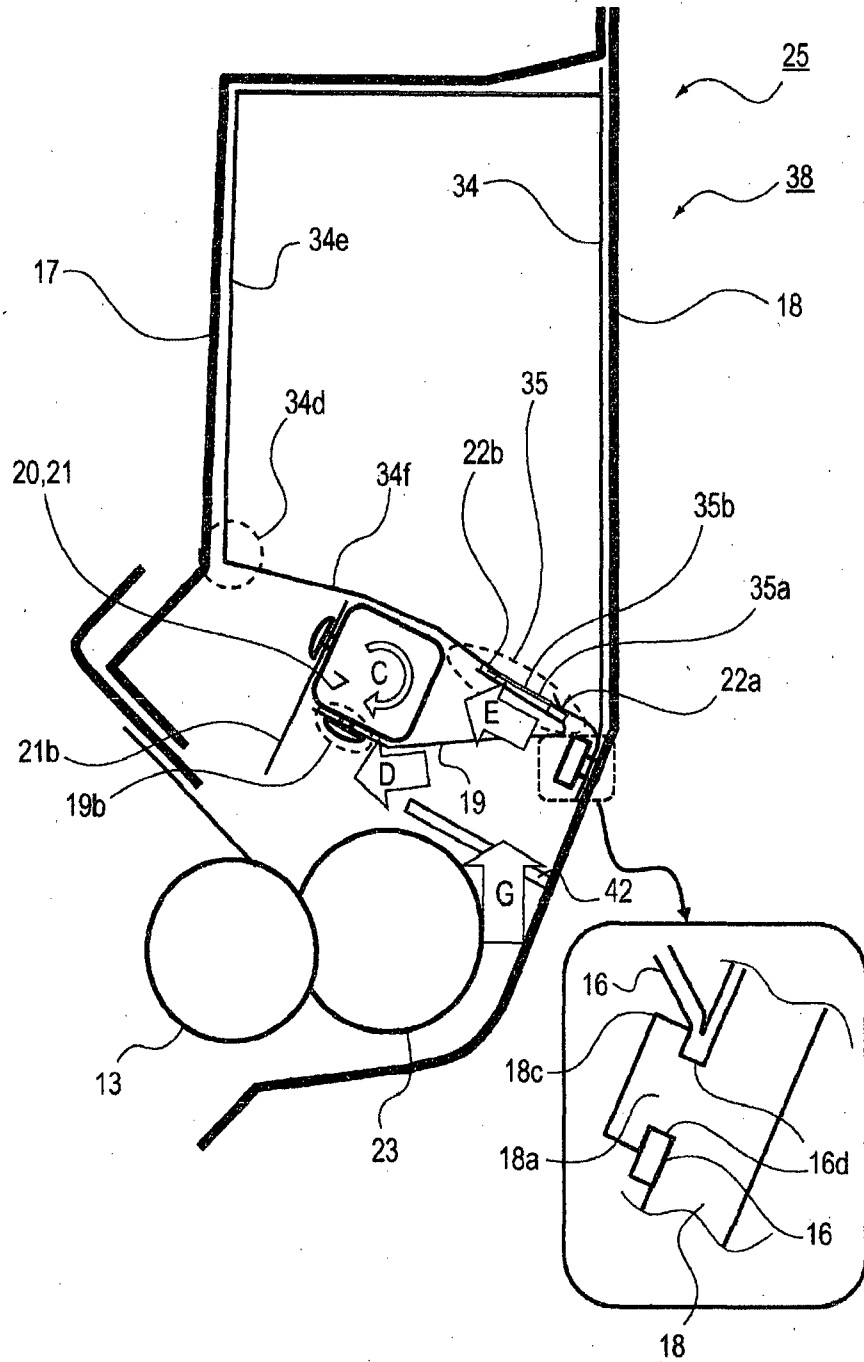

Fig. 19

Canon Kabushiki Kaisha
Applicant

By:

C. RISEL G. CASTILLO-TALEON

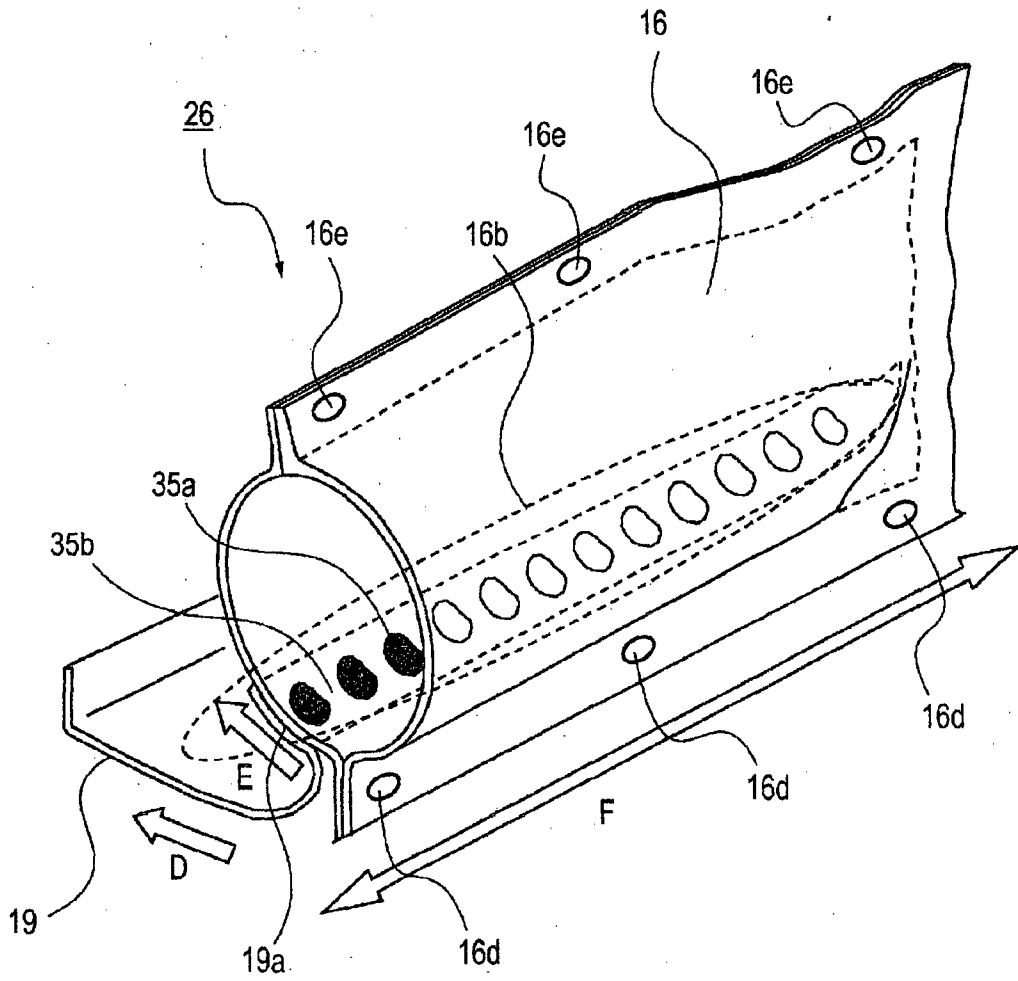

Fig. 20

Canon Kabushiki Kaisha
Applicant

By:

C. RISEL G. CASTILLO-TALEON

(a)

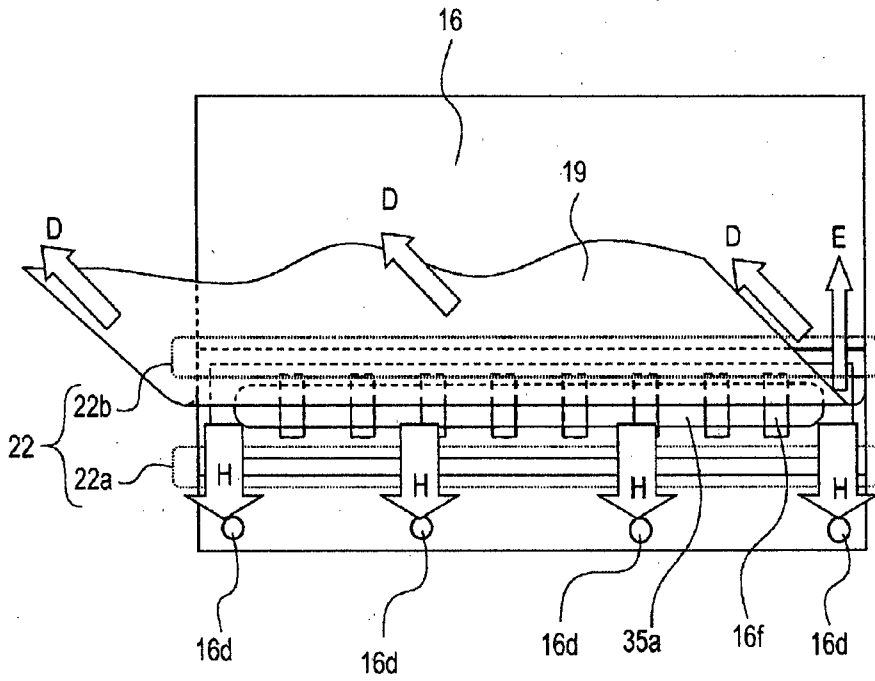

(b)

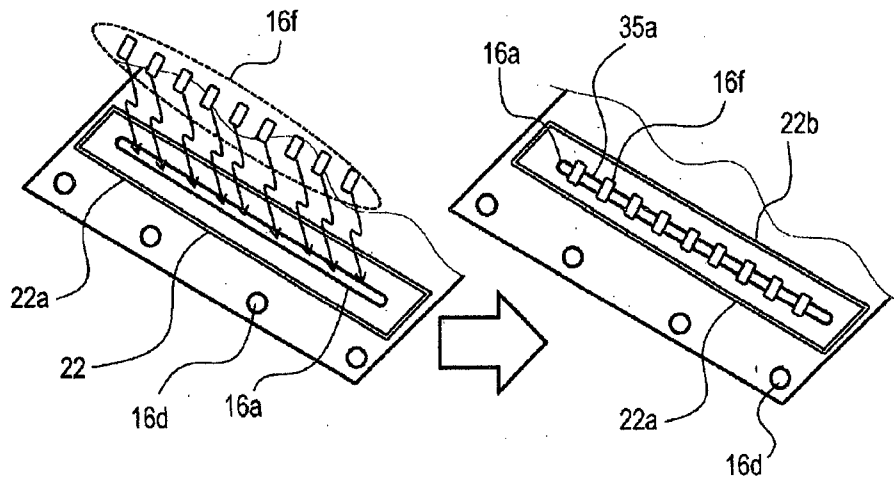

Fig. 21

Canon Kabushiki Kaisha
Applicant

By:

C. RISEL G. CASTILLO-TALEON

(a)

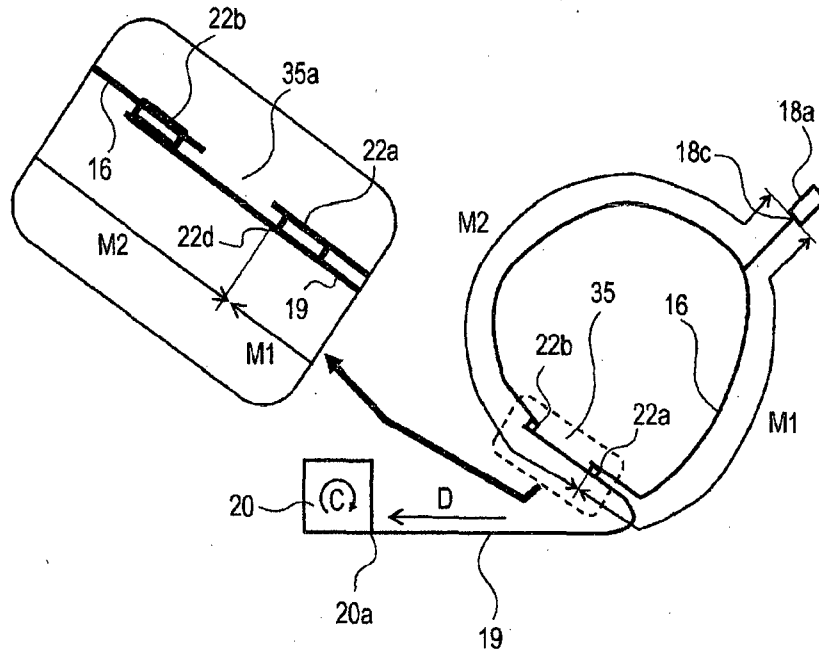

(b)

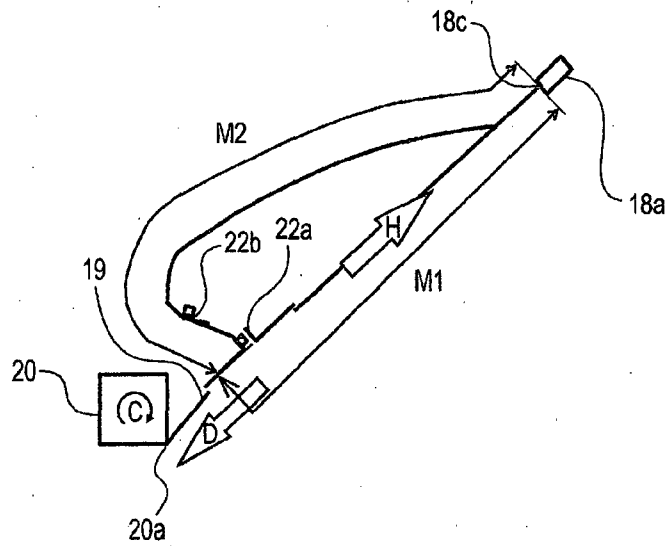

Fig. 22

Canon Kabushiki Kaisha
Applicant

By:

C. RISEL G. CASTILLO-TALEON

(a)

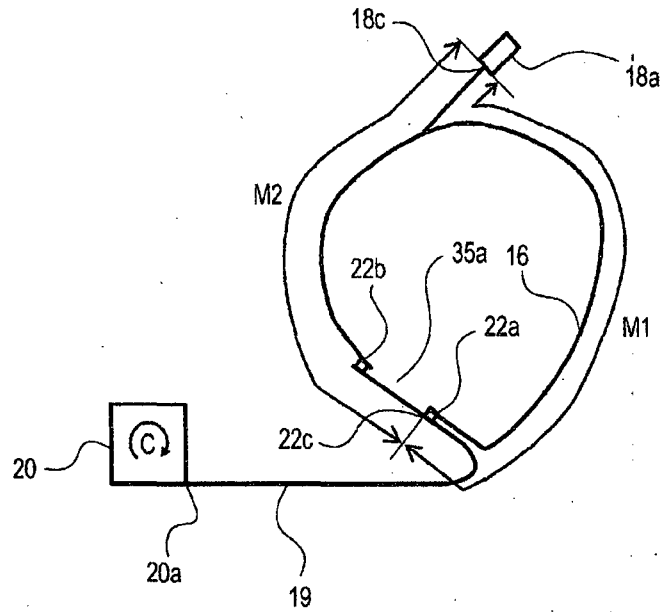

(b)

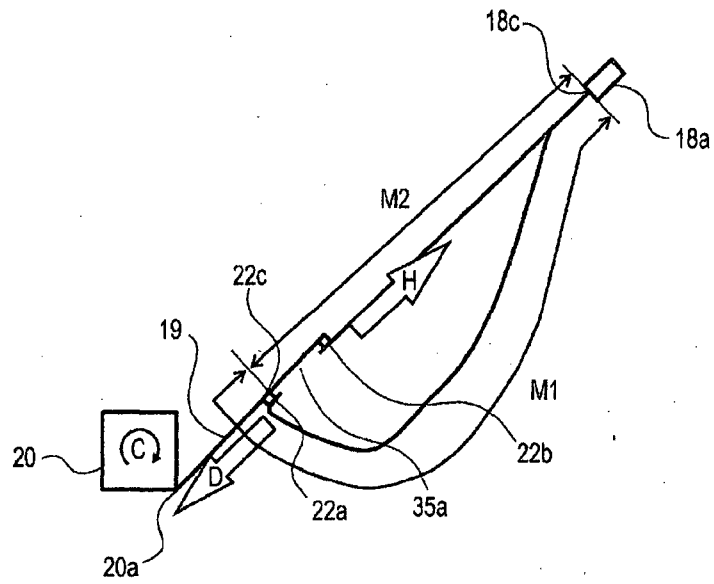

Fig. 23

Canon Kabushiki Kaisha
Applicant

By:

C. RISEL G. CASTILLO-TALEON

(a)

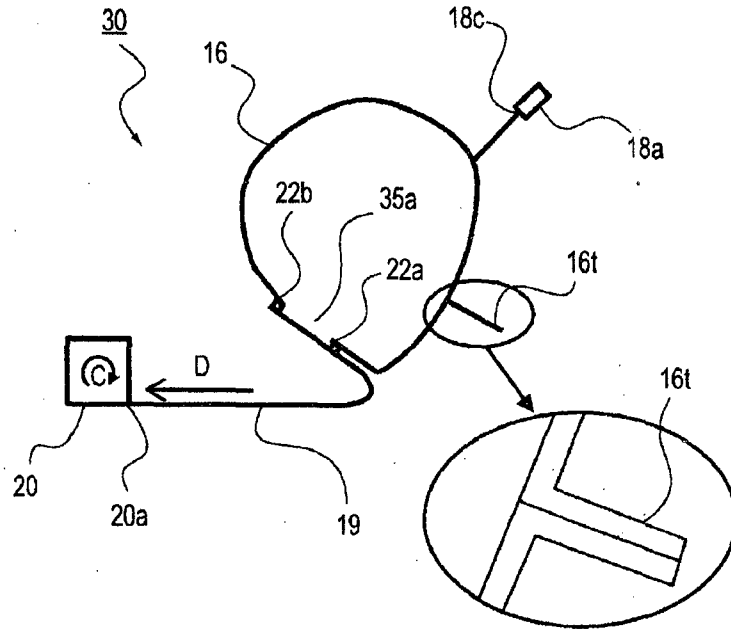

(b)

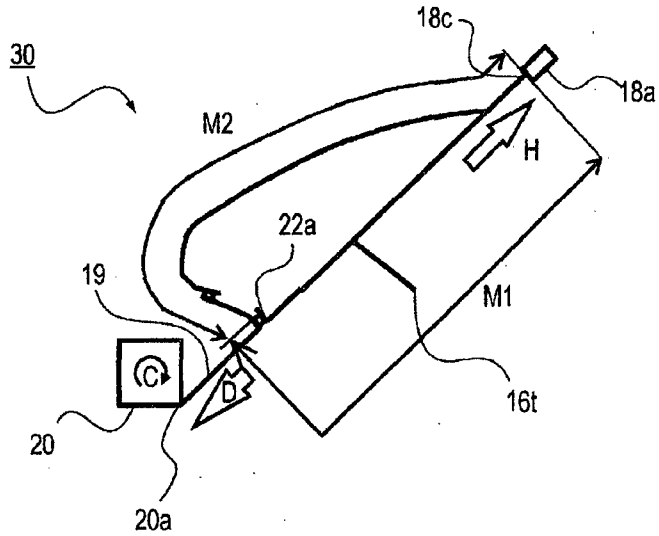

Fig. 24

Canon Kabushiki Kaisha
Applicant

By:

C. RISEL G. CASTILLO-TALEON

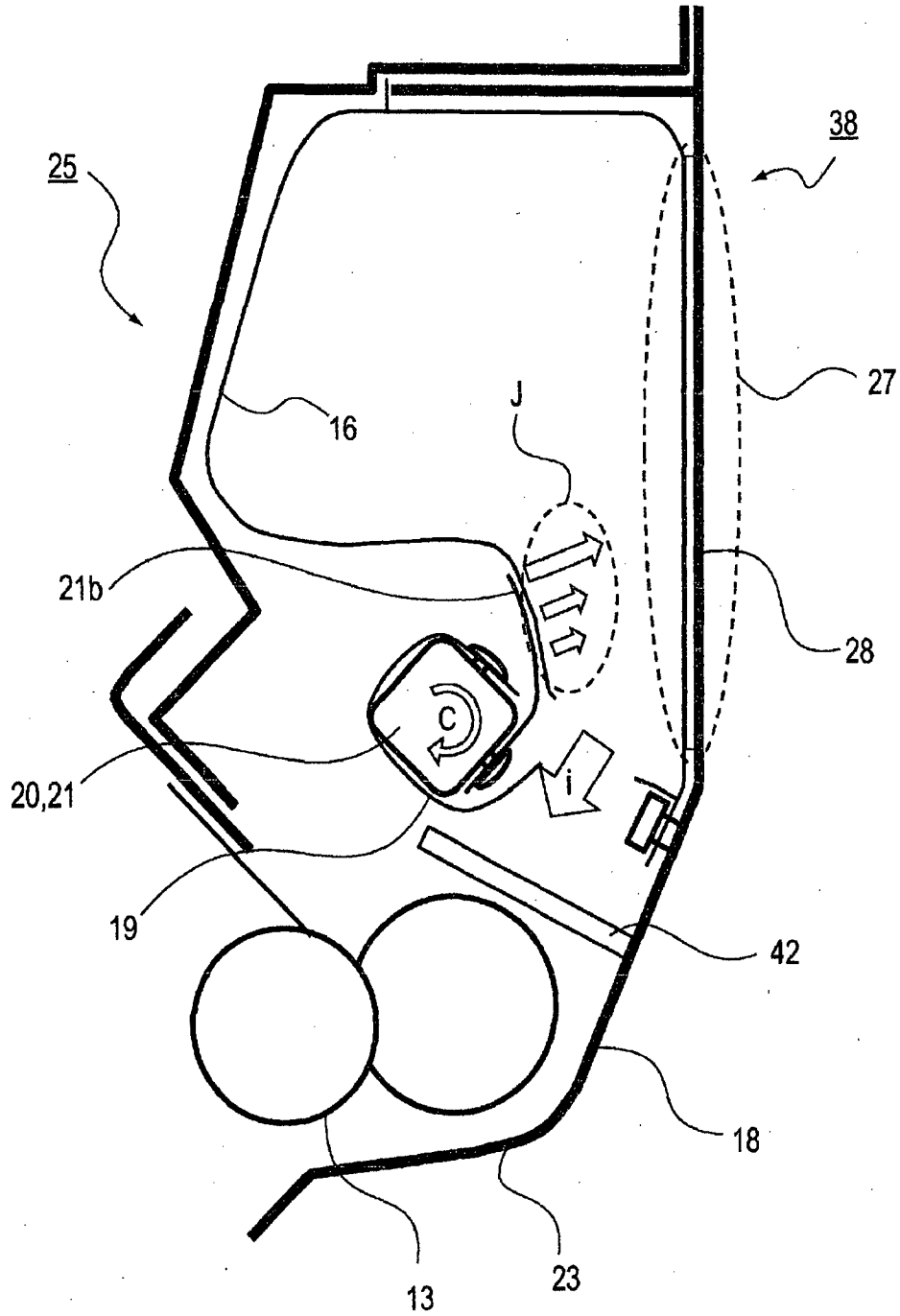

Fig. 25

Canon Kabushiki Kaisha
Applicant

By:

C. RISEL G. CASTILLO-TALEON

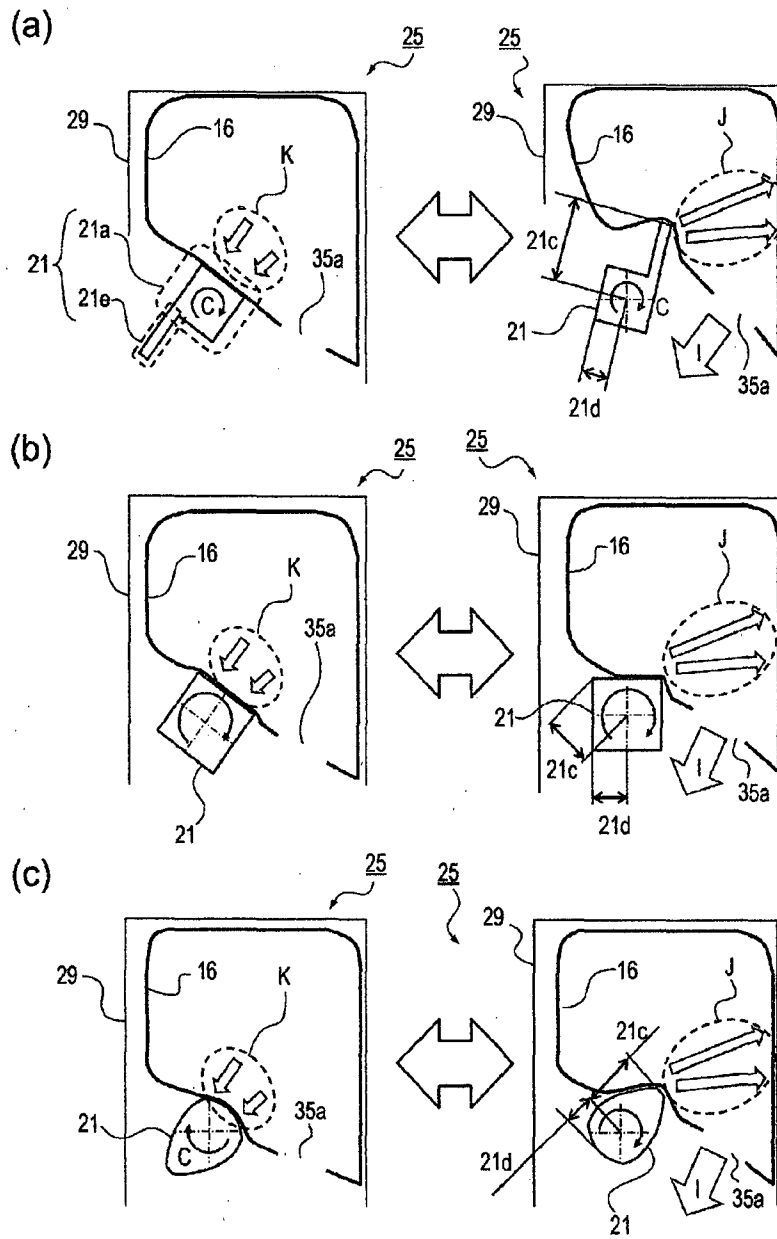

Fig. 26

Canon Kabushiki Kaisha
Applicant

By:

C. RISEL G. CASTILLO-TALEON

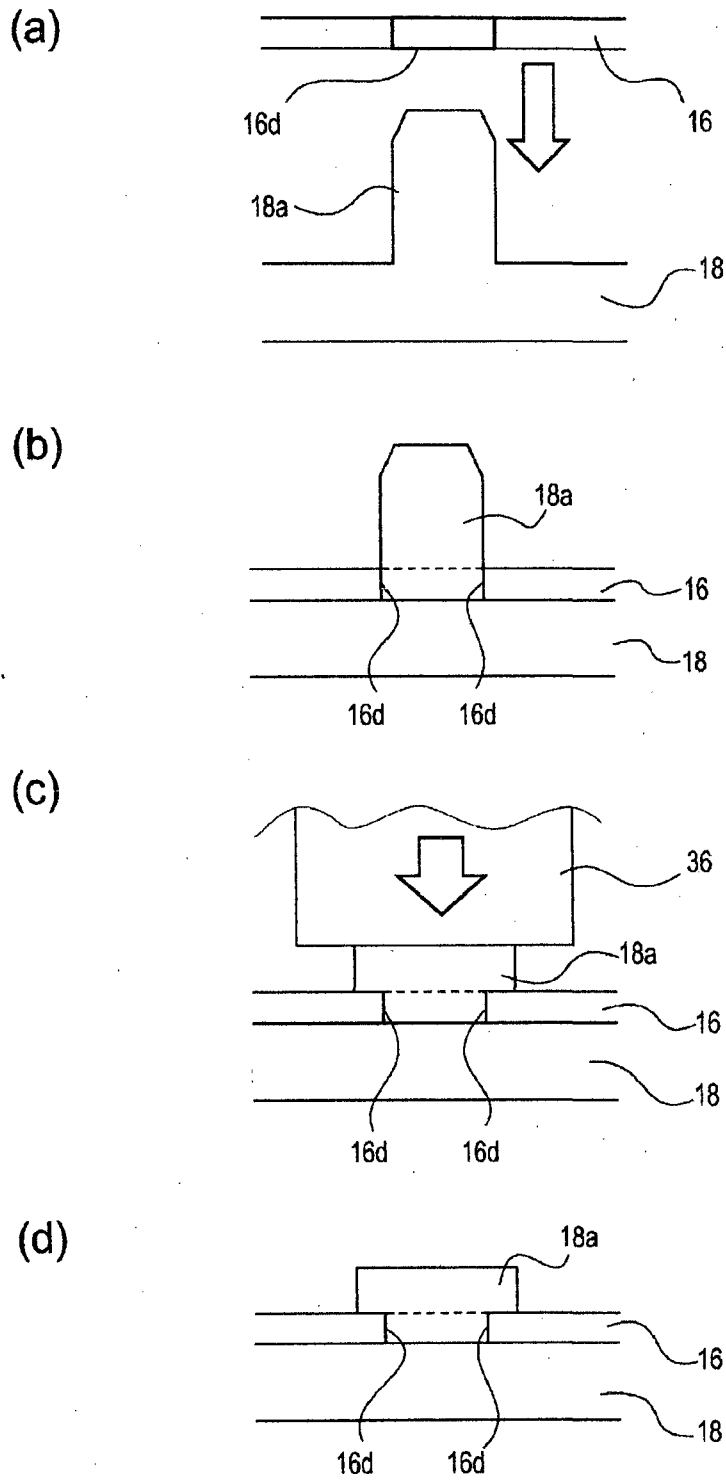

Fig. 27

Canon Kabushiki Kaisha
Applicant

By:

C. RISEL G. CASTILLO-TALEON

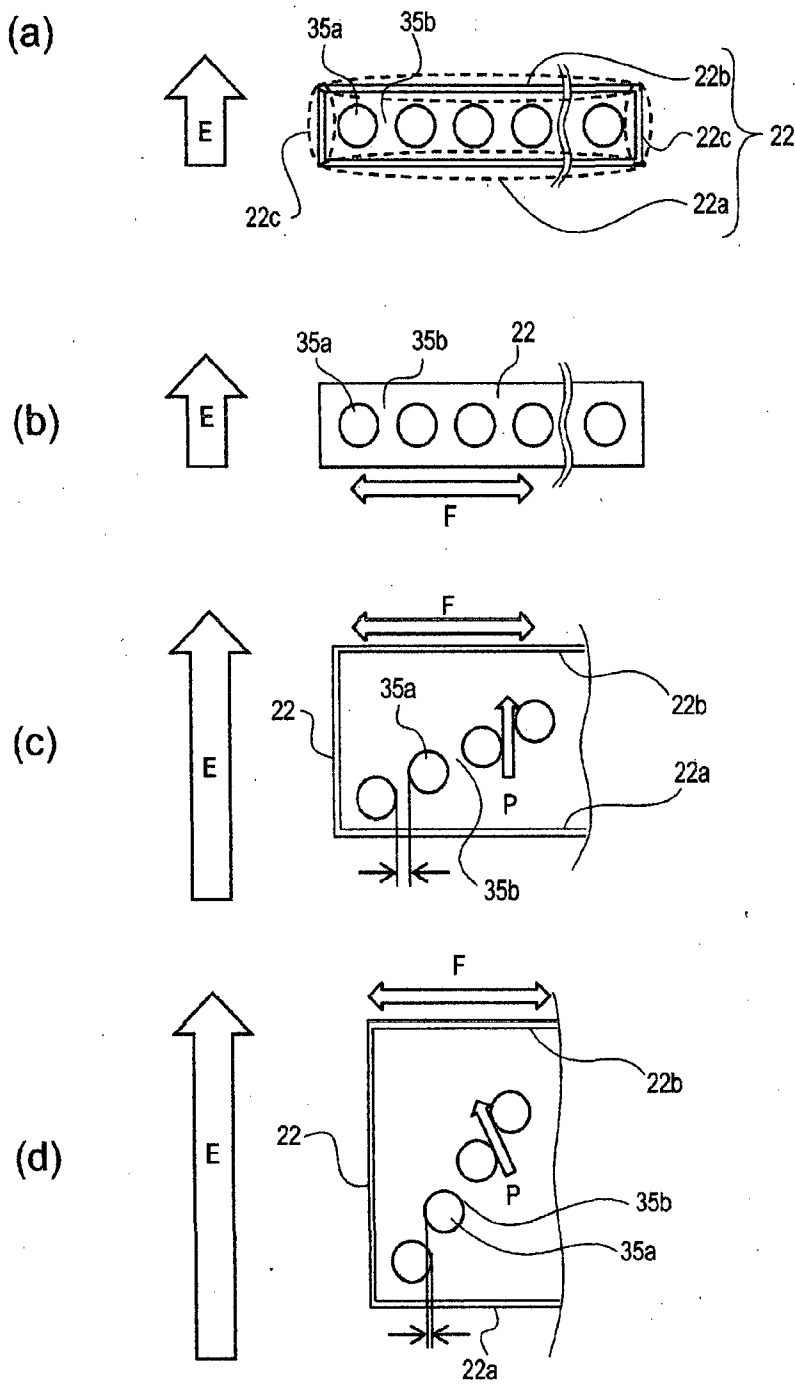

Fig. 28

Canon Kabushiki Kaisha
Applicant

By: *[Signature]*
C. RISEL G. CASTILLO-TALEON

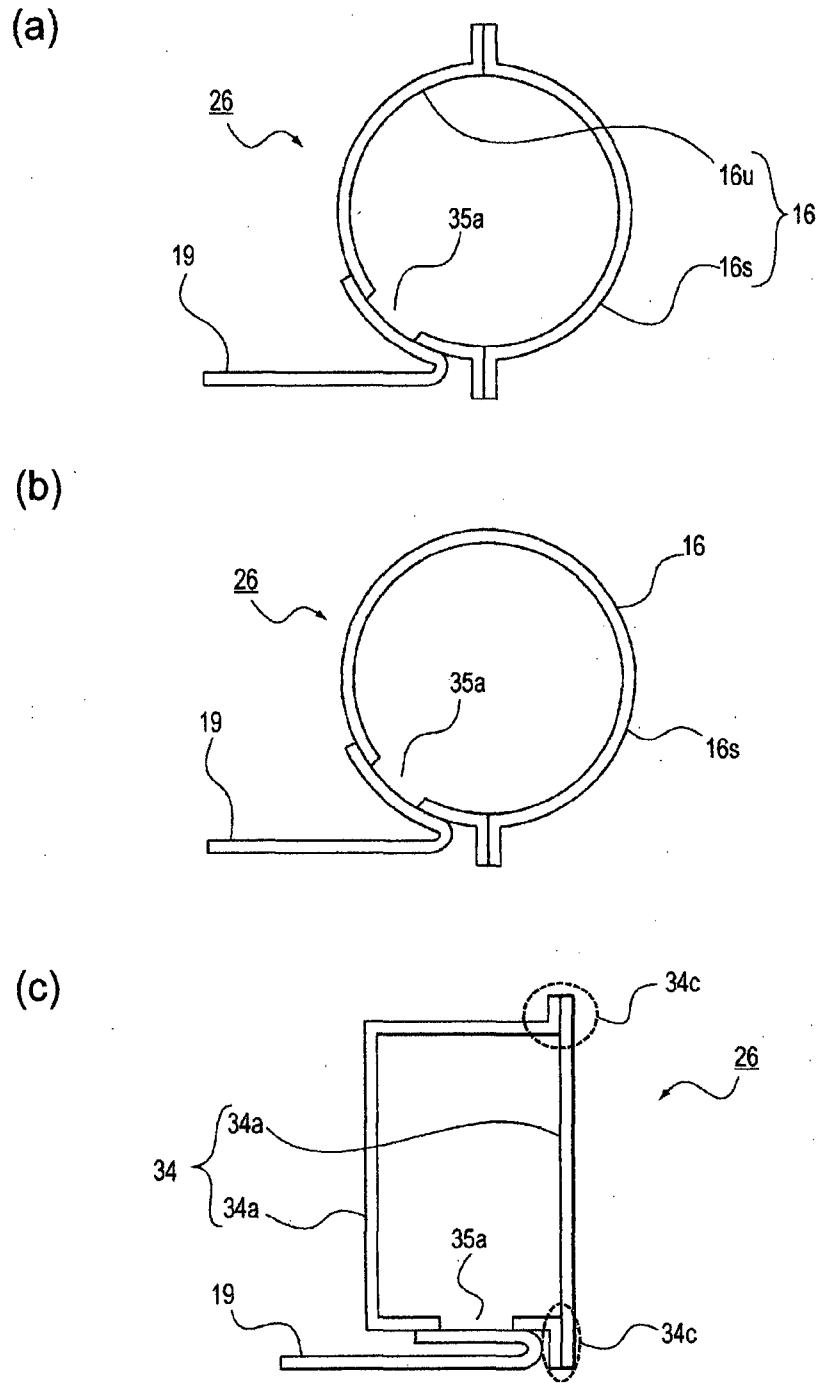

Fig. 29

Canon Kabushiki Kaisha
Applicant

By:

C. RISEL G. CASTILLO-TALEON

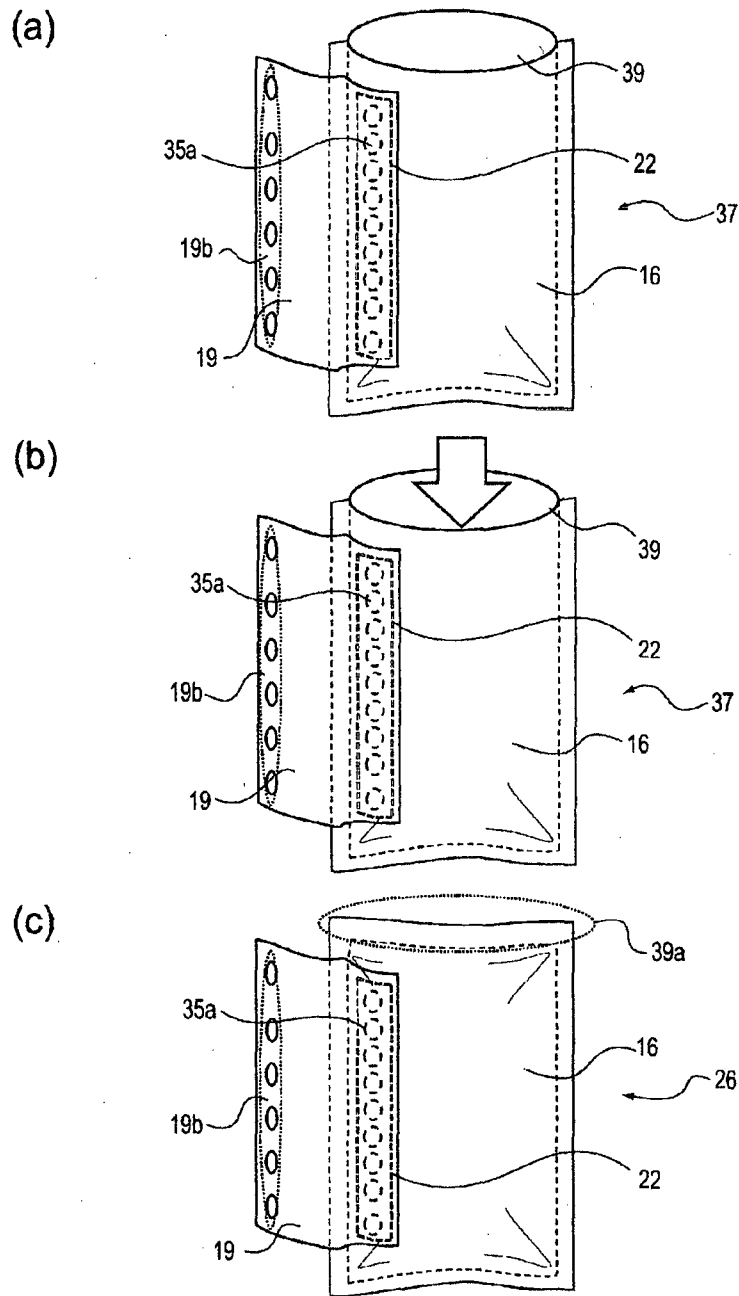

Fig. 30

Canon Kabushiki Kaisha
Applicant

By:

C. RISEL G. CASTILLO-TALEON

(a)

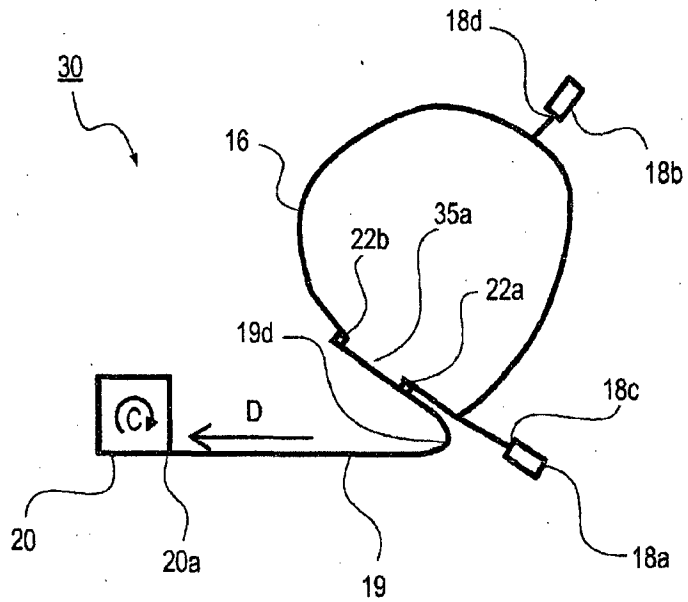

(b)

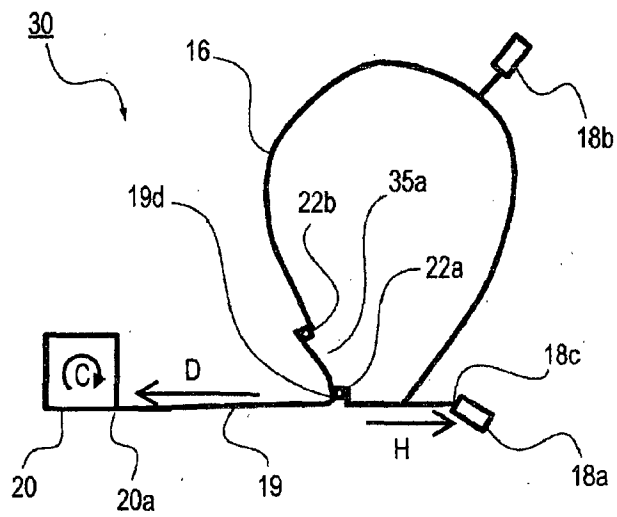

Fig. 31

Canon Kabushiki Kaisha
Applicant

By:

C. RISEL G. CASTILLO-TALEON

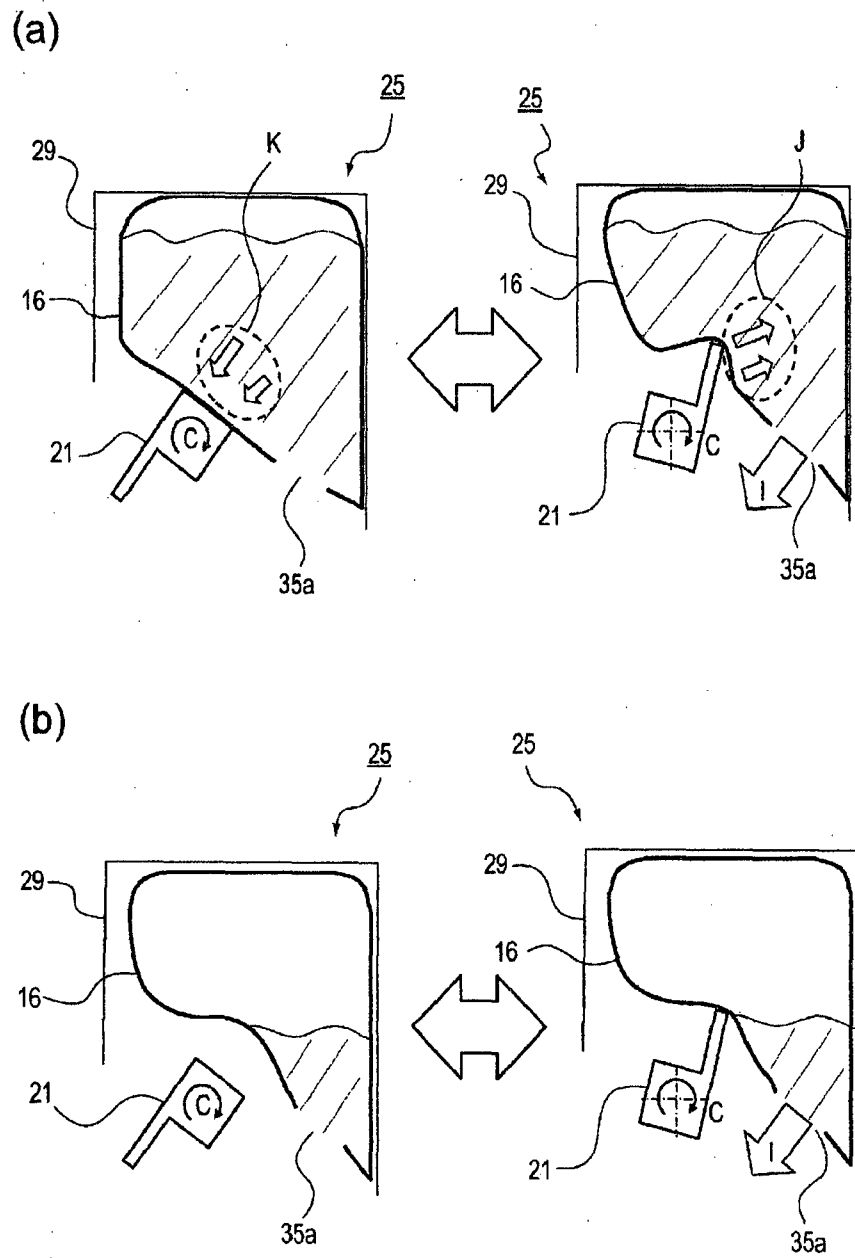

Fig. 32

Canon Kabushiki Kaisha
Applicant

By:

C. RISEL G. CASTILLO-TALEON

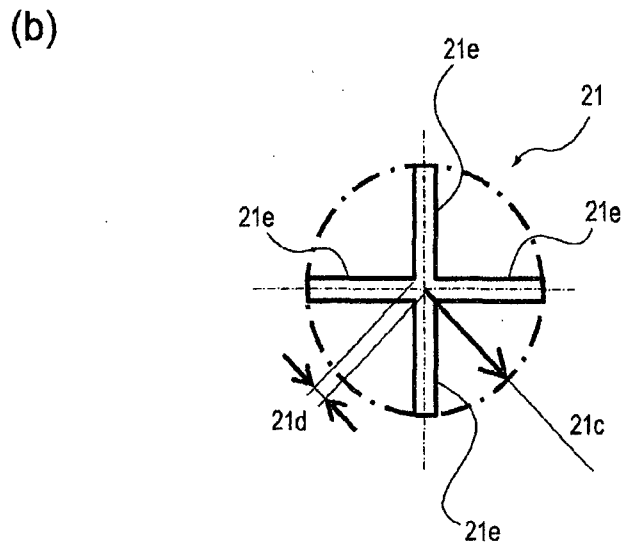
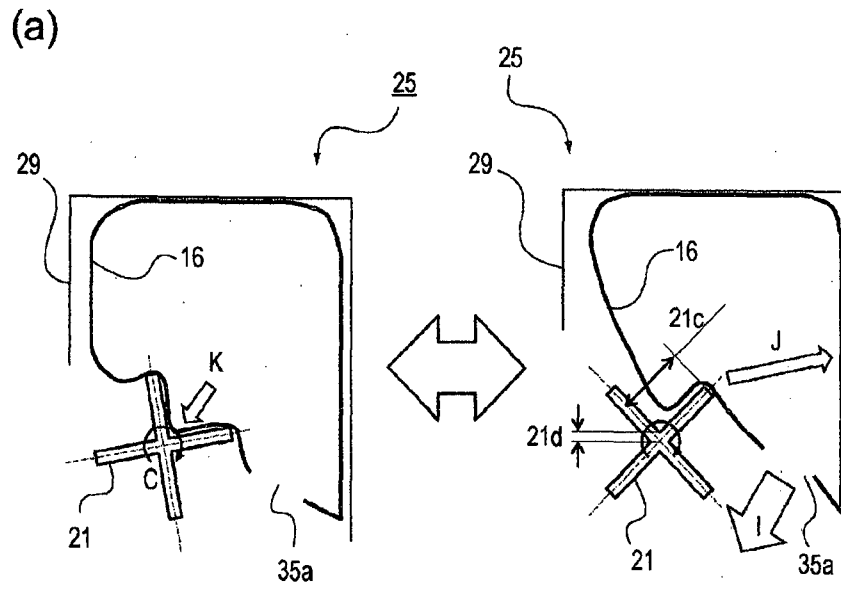

Fig. 33

Canon Kabushiki Kaisha
Applicant

By:

C. RISEL G. CASTILLO-TALEON

06/09/2018 10:02 04751

(a)

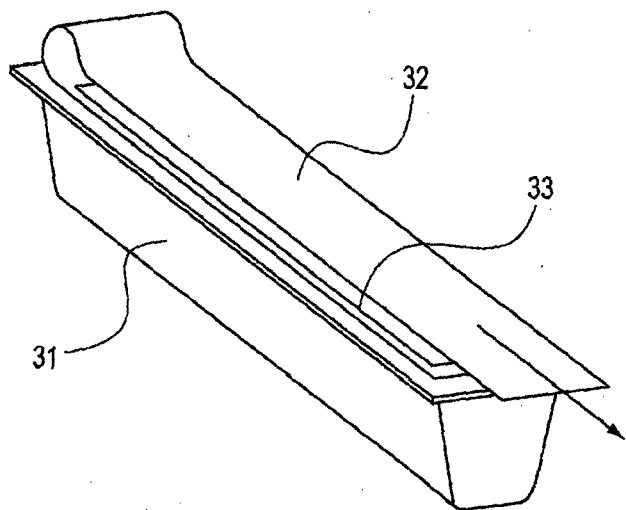

(b)

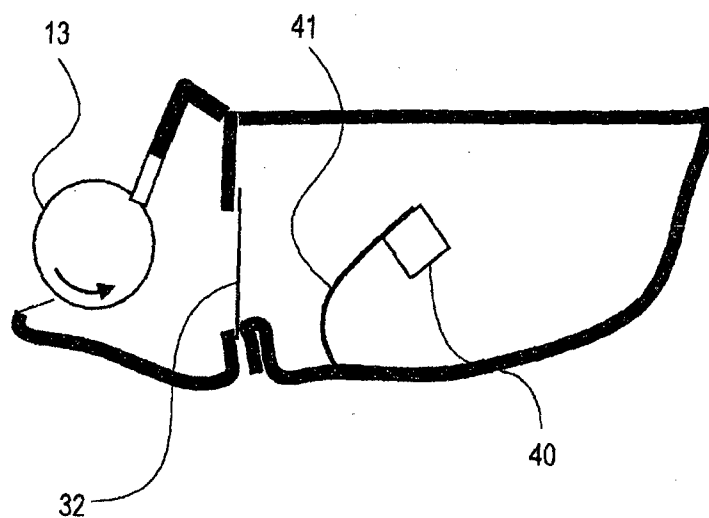

Fig. 34

Canon Kabushiki Kaisha
Applicant

By:

C. RISEL G. CASTILLO-TALEON

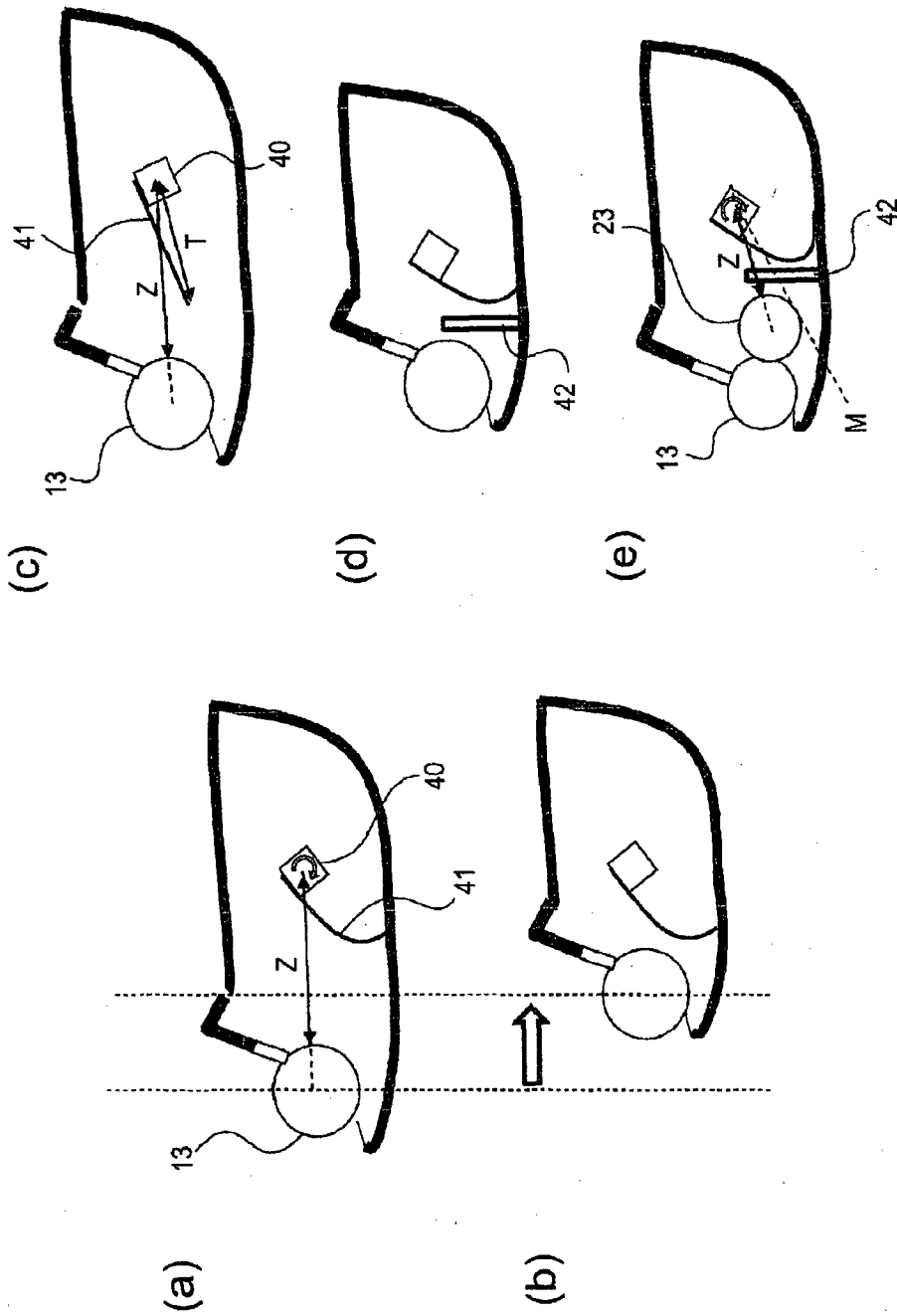

Fig. 35

Canon Kabushiki Kaisha
Applicant

By:

C. RISEL G. CASTILLO-TALEON

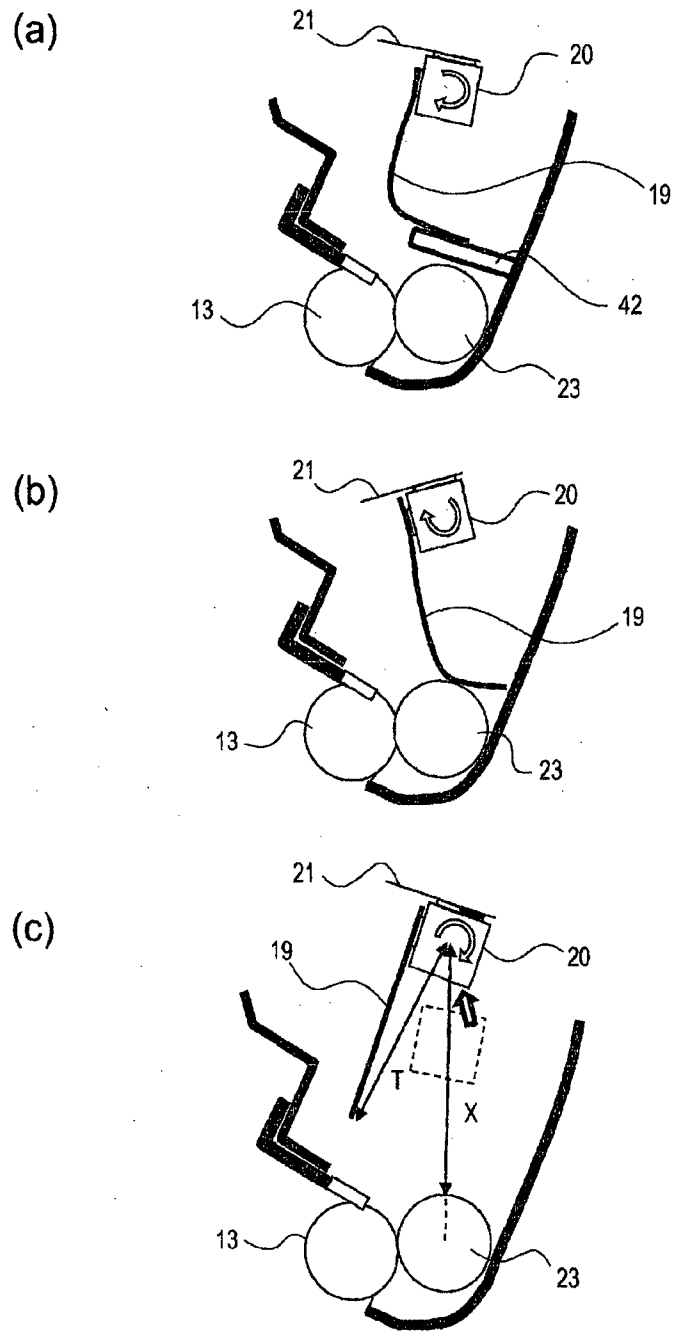

Fig. 36

Canon Kabushiki Kaisha
Applicant

By:

C. RISEL G. CASTILLO-TALEON

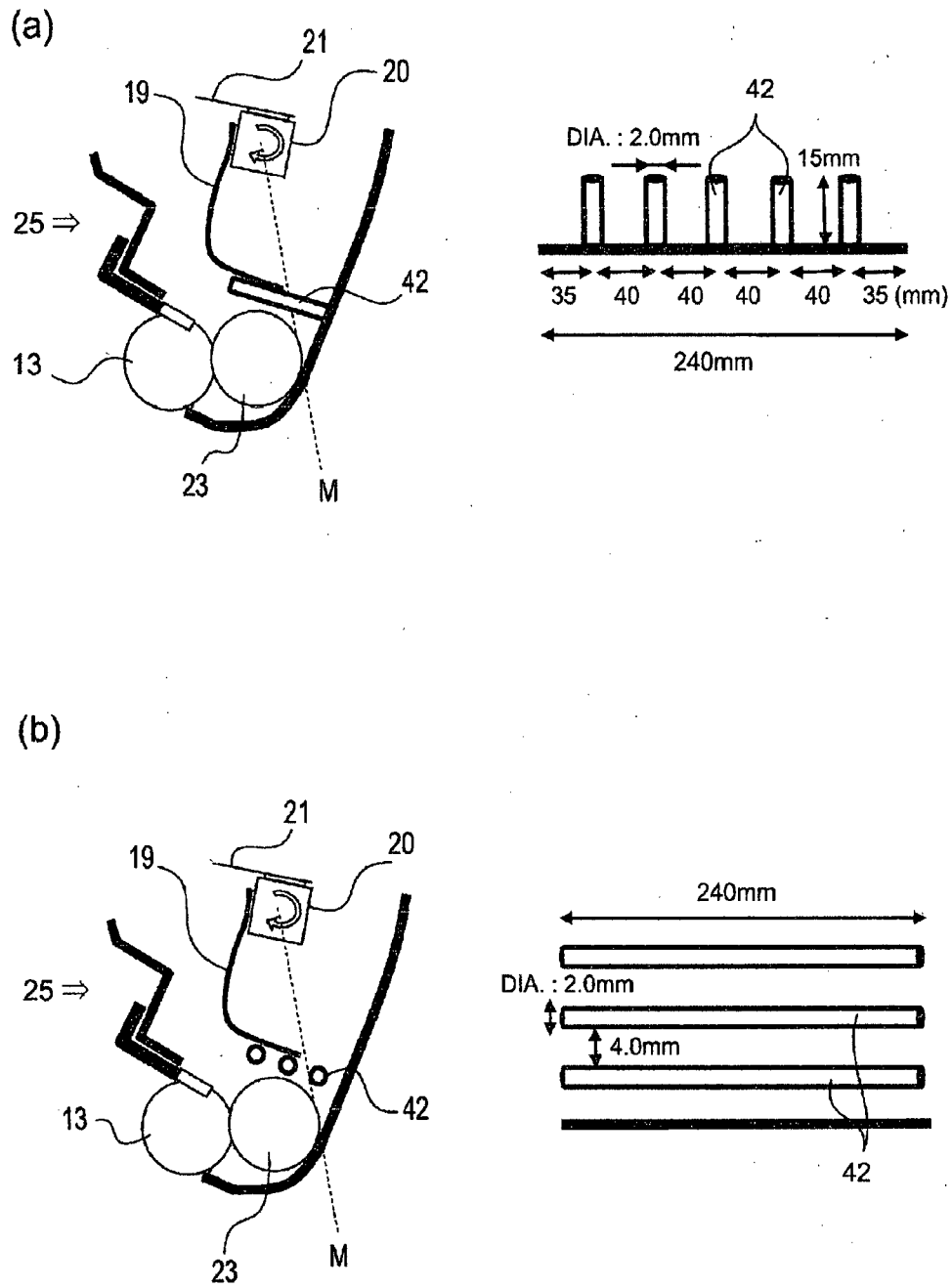

Fig. 37

Canon Kabushiki Kaisha
Applicant

By:

C. RISEL G. CASTILLO-TALEON

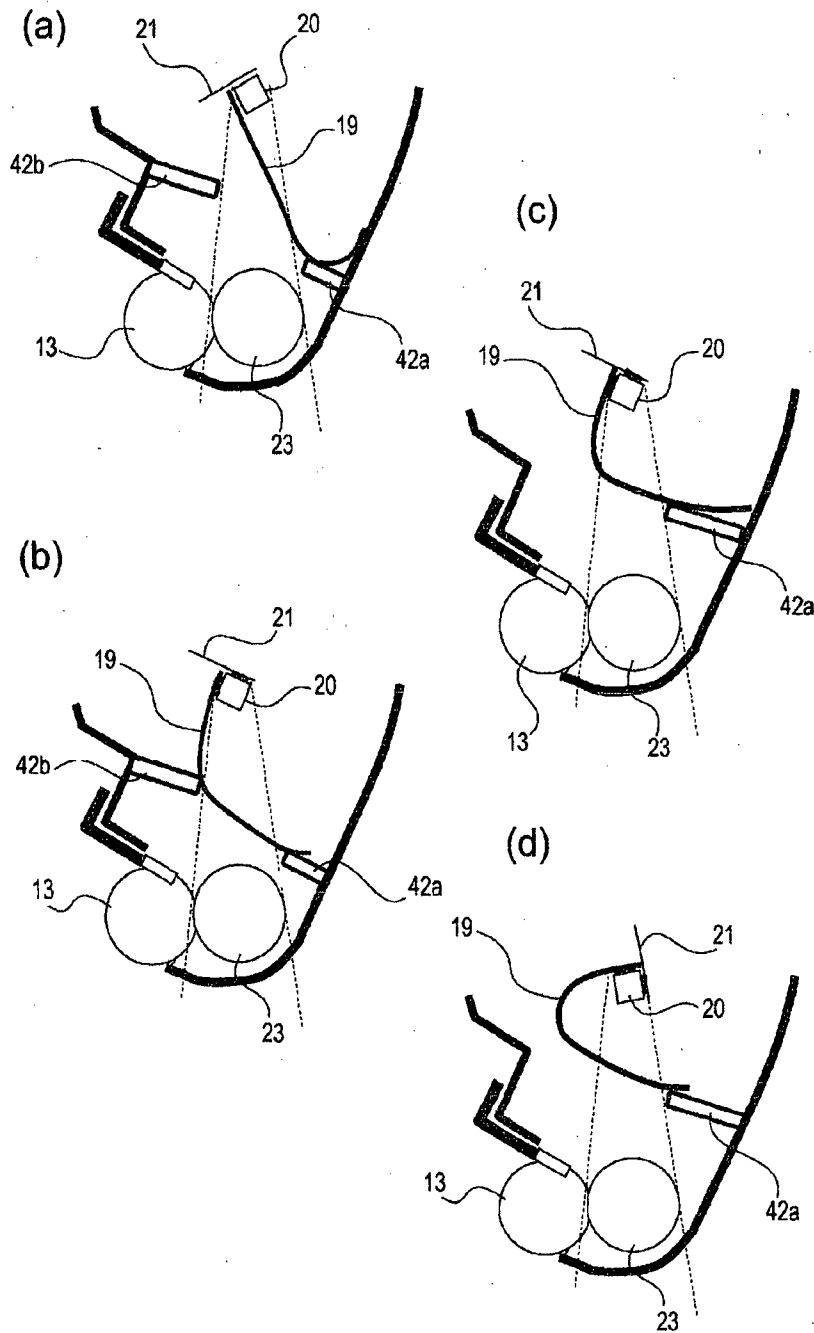

Fig. 38

Canon Kabushiki Kaisha
Applicant

By:

C. RISEL G. CASTILLO-TALEON

(a)

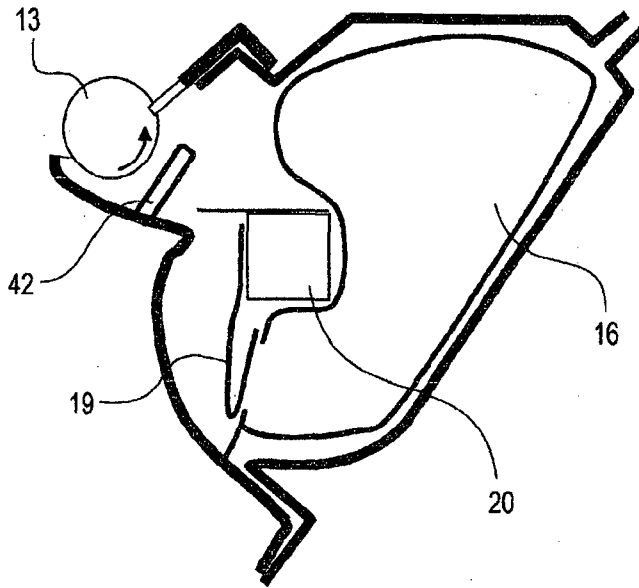

(b)

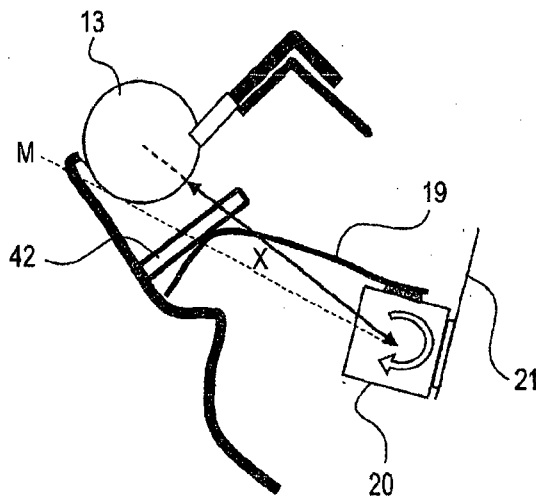

Fig. 39

Canon Kabushiki Kaisha
Applicant

By:

C. RISEL G. CASTILLO-TALEON

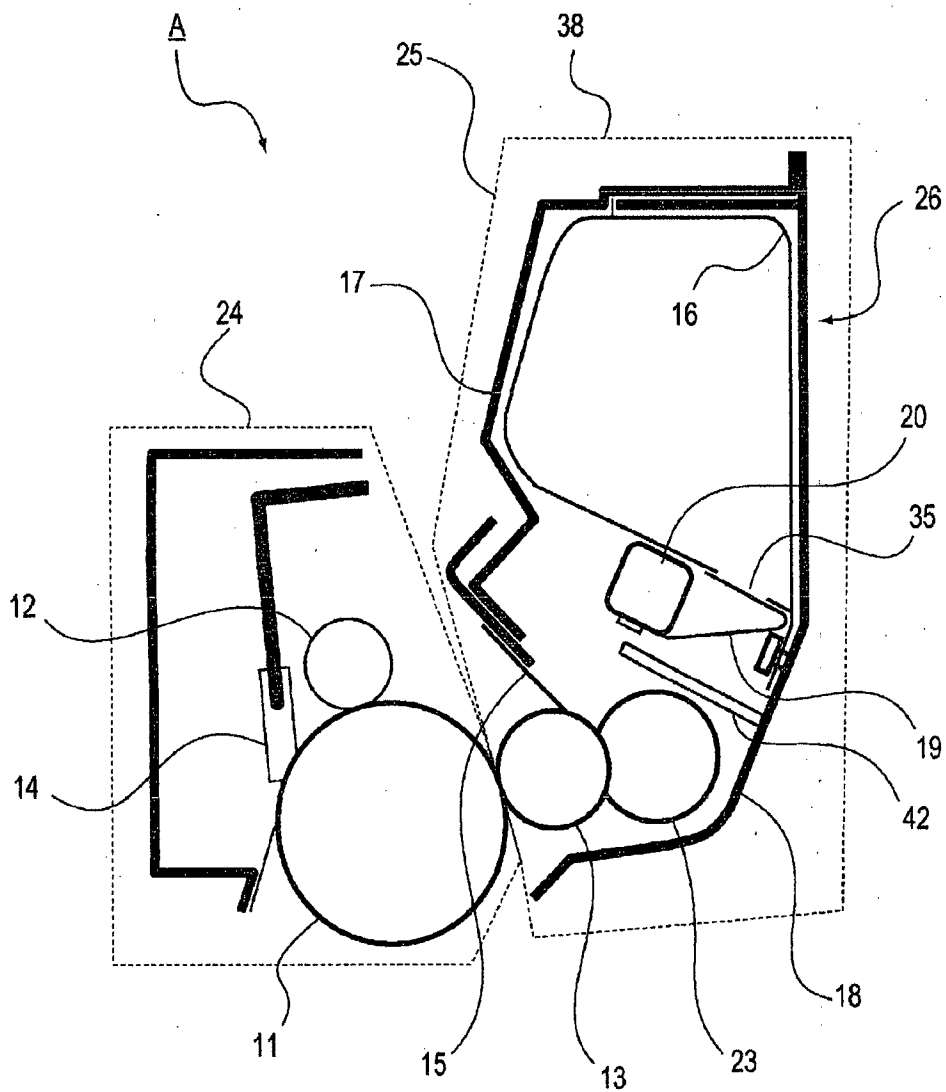

Fig. 40

Canon Kabushiki Kaisha
Applicant

By:

C. RISEL G. CASTILLO-TALEON

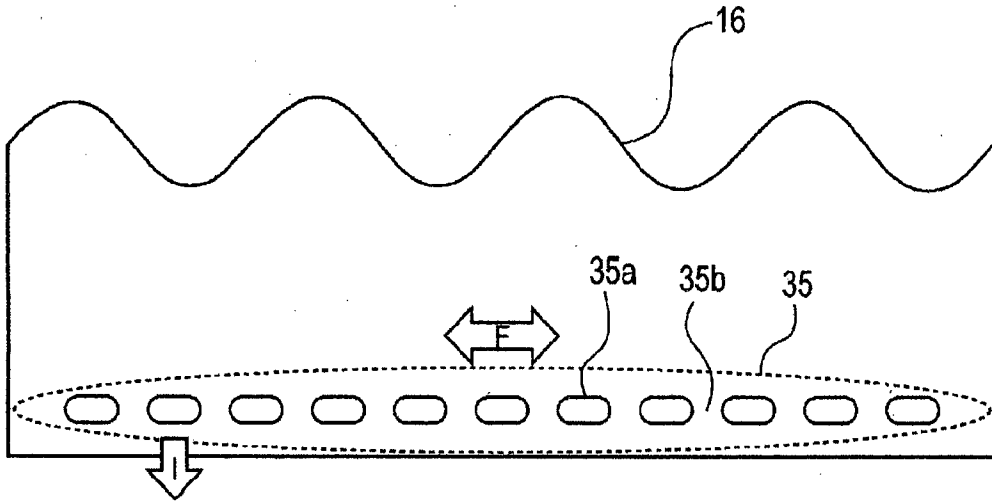

Fig. 41

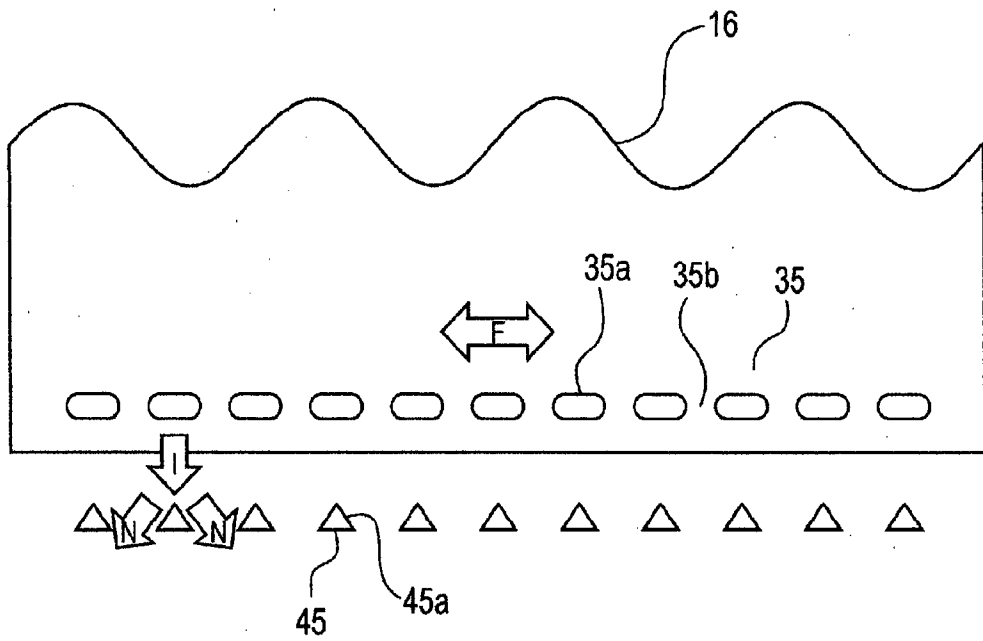

Fig. 42

Canon Kabushiki Kaisha
Applicant

By:

C. RISEL G. CASTILLO-TALEON

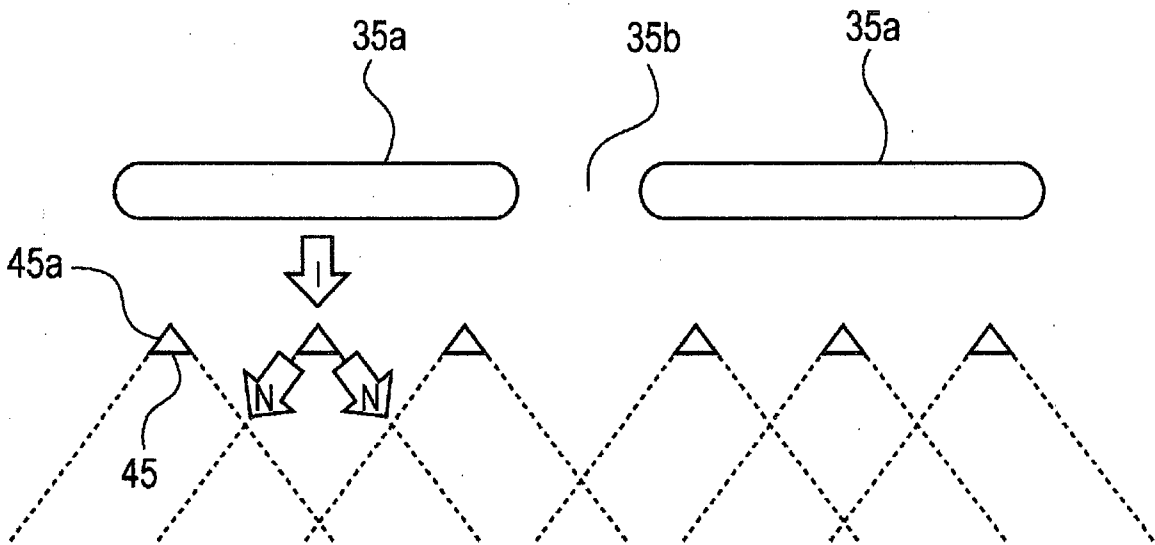

Fig. 43

Canon Kabushiki Kaisha
Applicant

By:

C. RISEL G. CASTILLO-TALEON

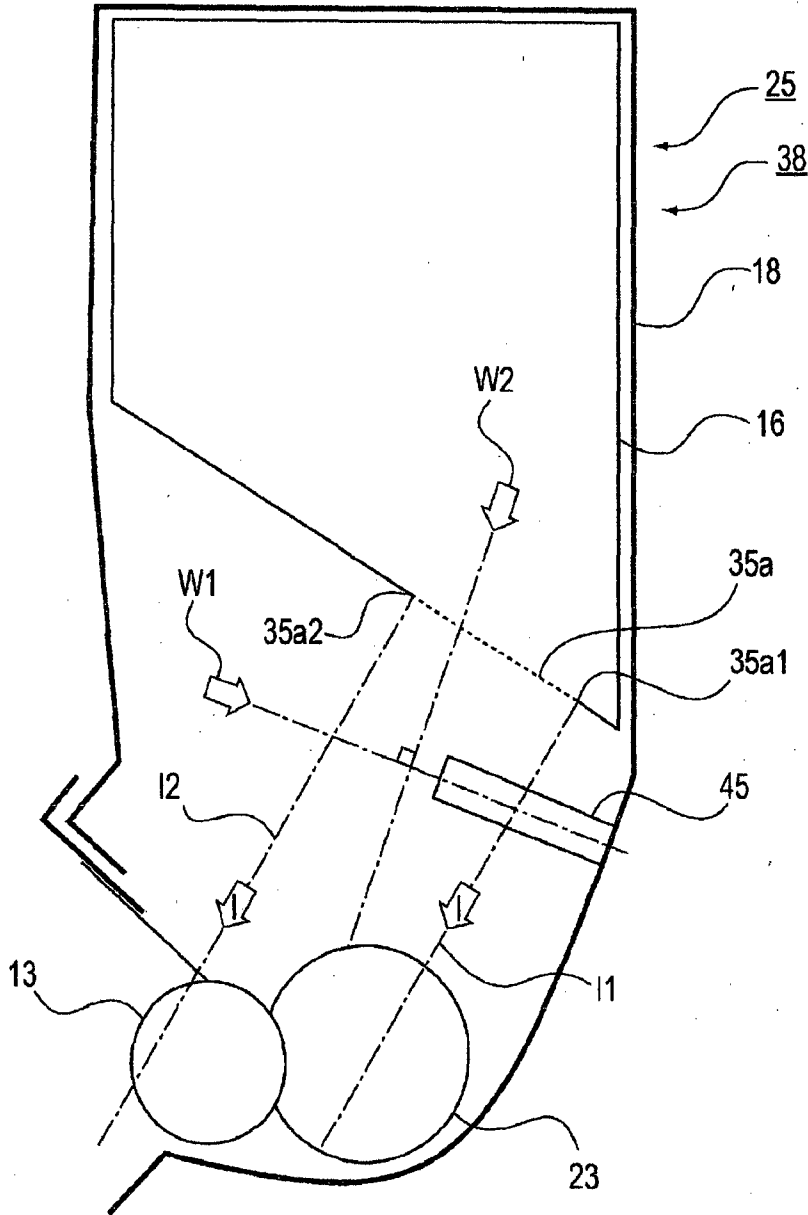

Fig. 44

Canon Kabushiki Kaisha
Applicant

By: *[Signature]*
C. RISEL G. CASTILLO-TALEON

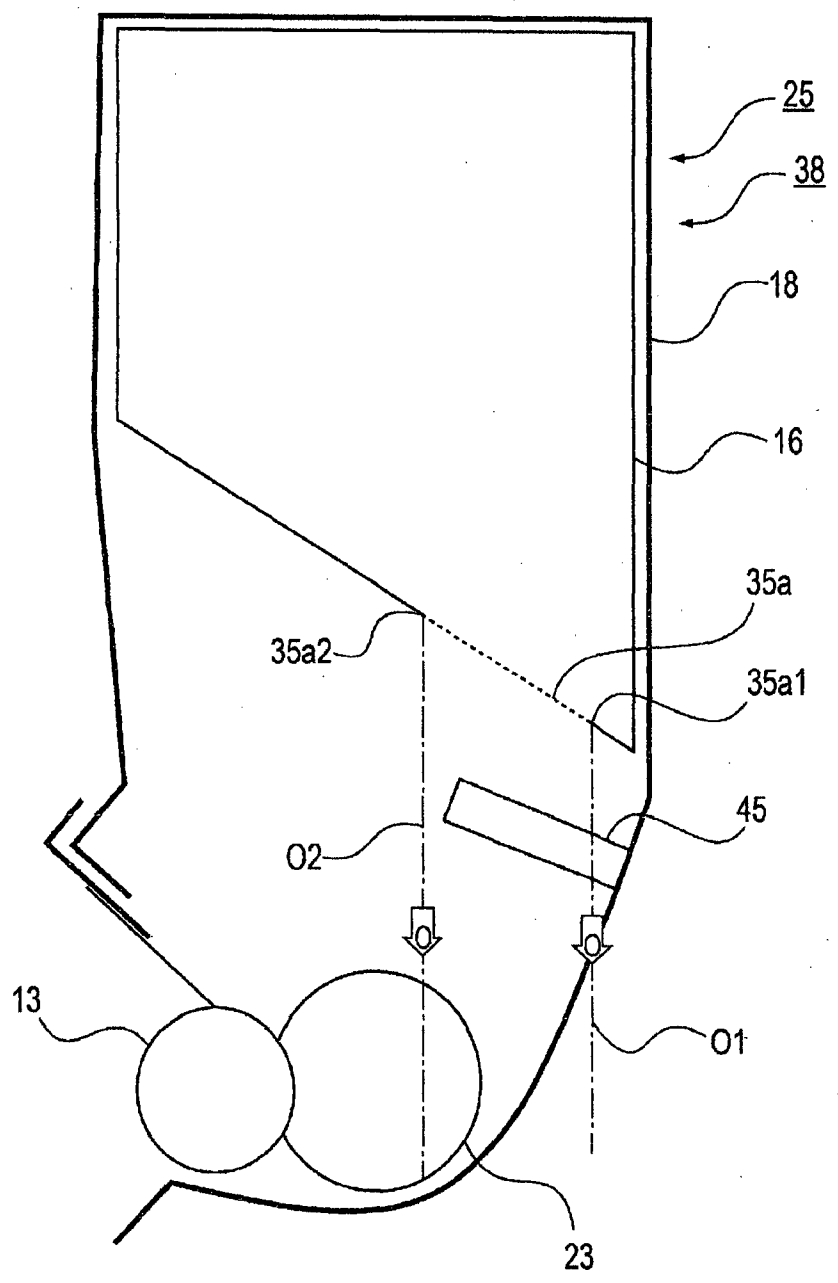

Fig. 45

Canon Kabushiki Kaisha
Applicant

By:

C. RISEL G. CASTILLO-TALEON

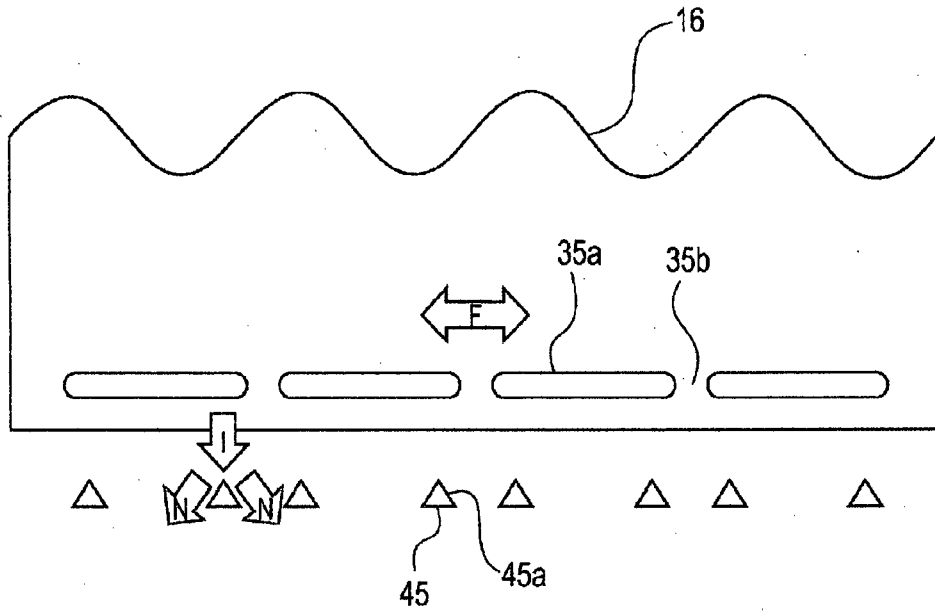

Fig. 46

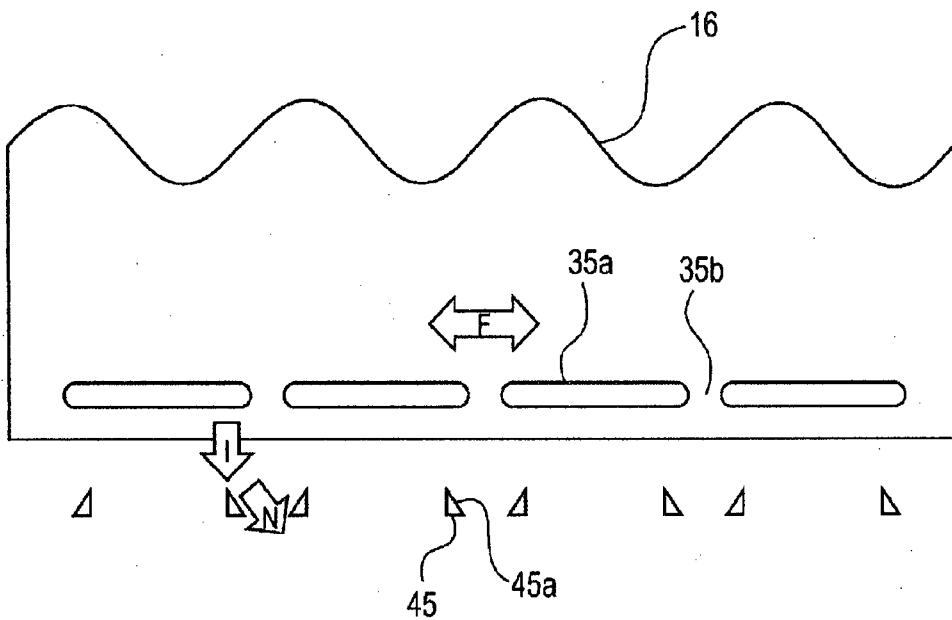

Fig. 47

Canon Kabushiki Kaisha
Applicant

By:

C. RISEL G. CASTILLO-TALEON

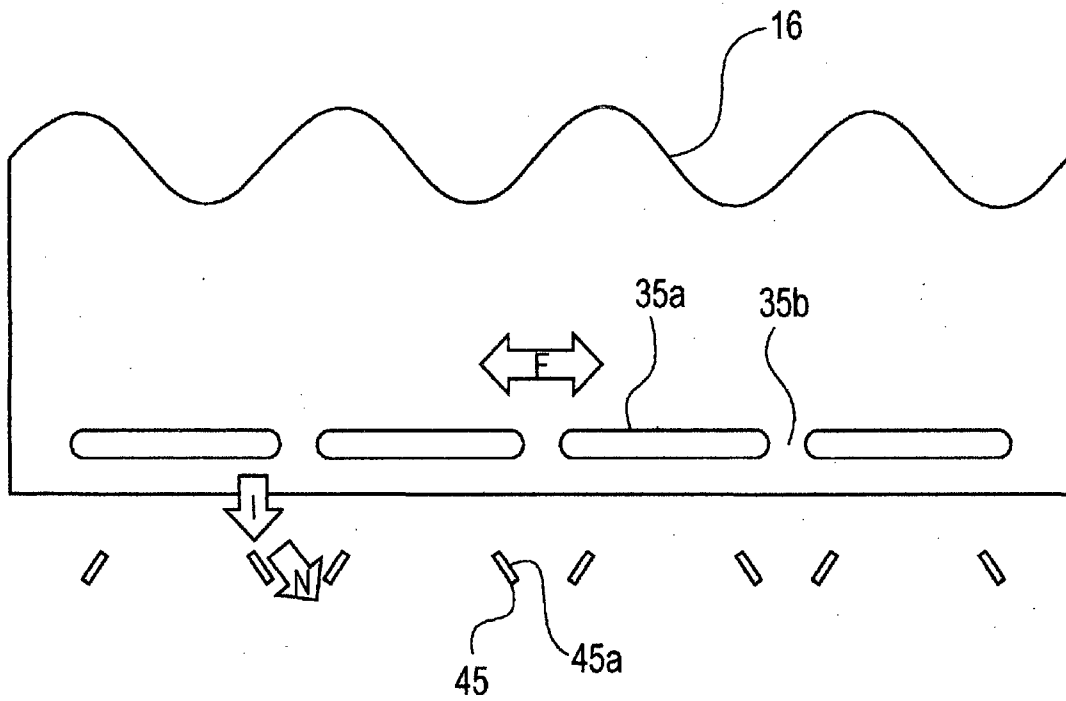

Fig. 48

Canon Kabushiki Kaisha
Applicant

By:

C. RISEL G. CASTILLO-TALEON

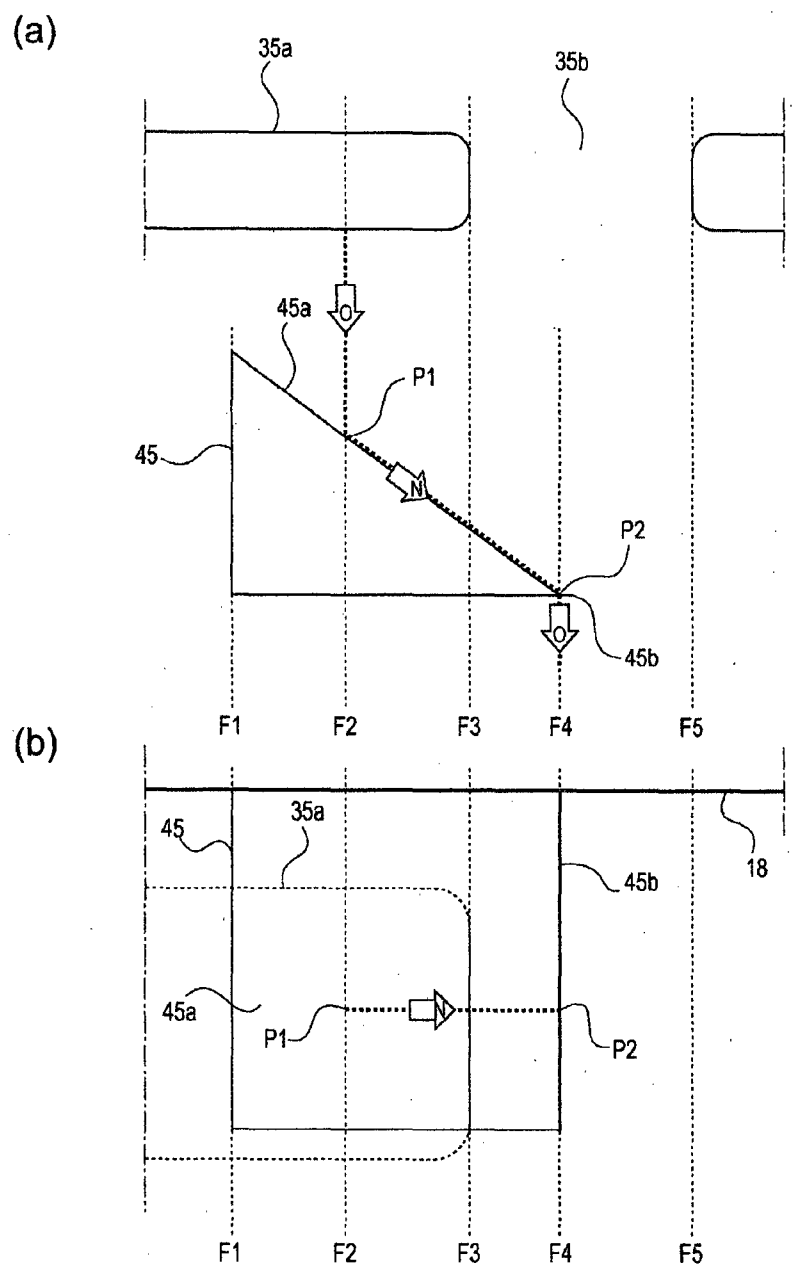



Fig. 49

Canon Kabushiki Kaisha
Applicant

By: 
C. RISEL G. CASTILLO-TALEON

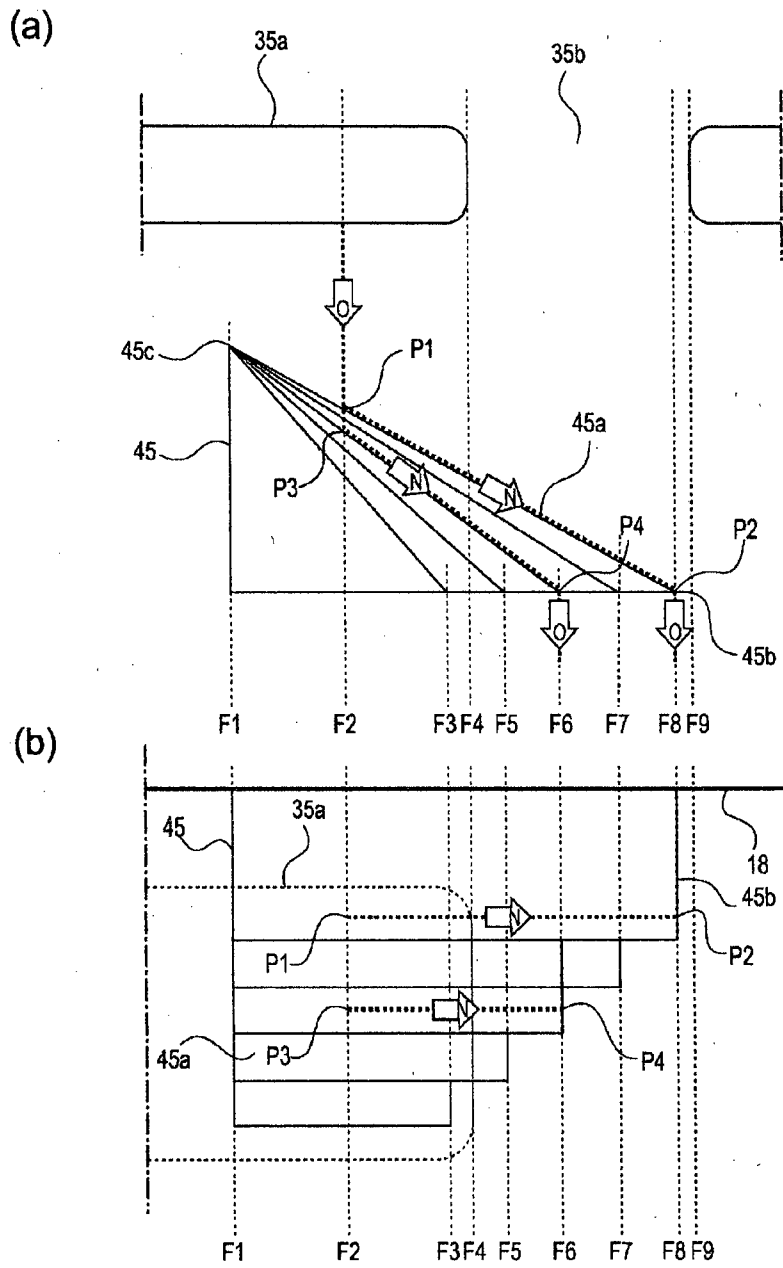

Fig. 50

Canon Kabushiki Kaisha
Applicant

By:

C. RISEL G. CASTILLO-TALEON

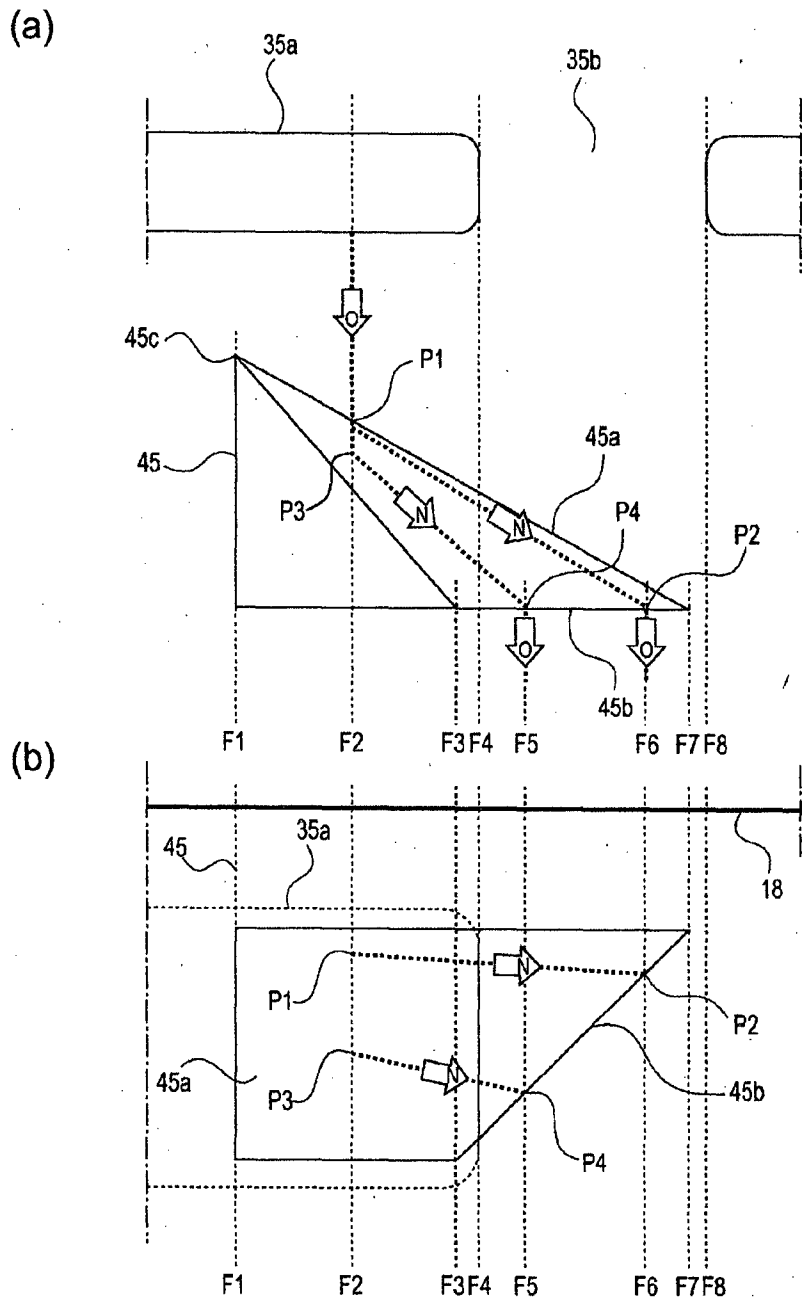

Fig. 51

Canon Kabushiki Kaisha
Applicant

By:

C. RISEL G. CASTILLO-TALEON

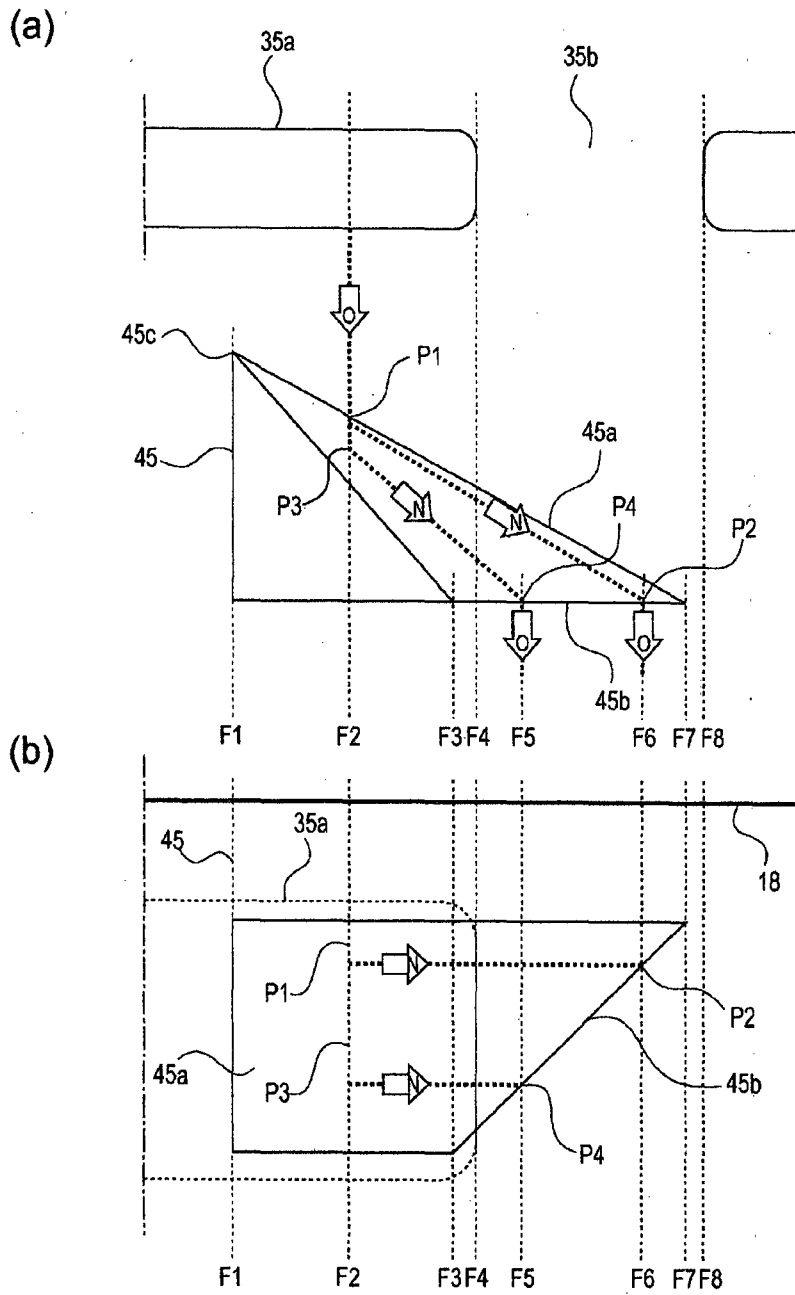

Fig. 52

Canon Kabushiki Kaisha
Applicant

By:

C. RISEL G. CASTILLO-TALEON

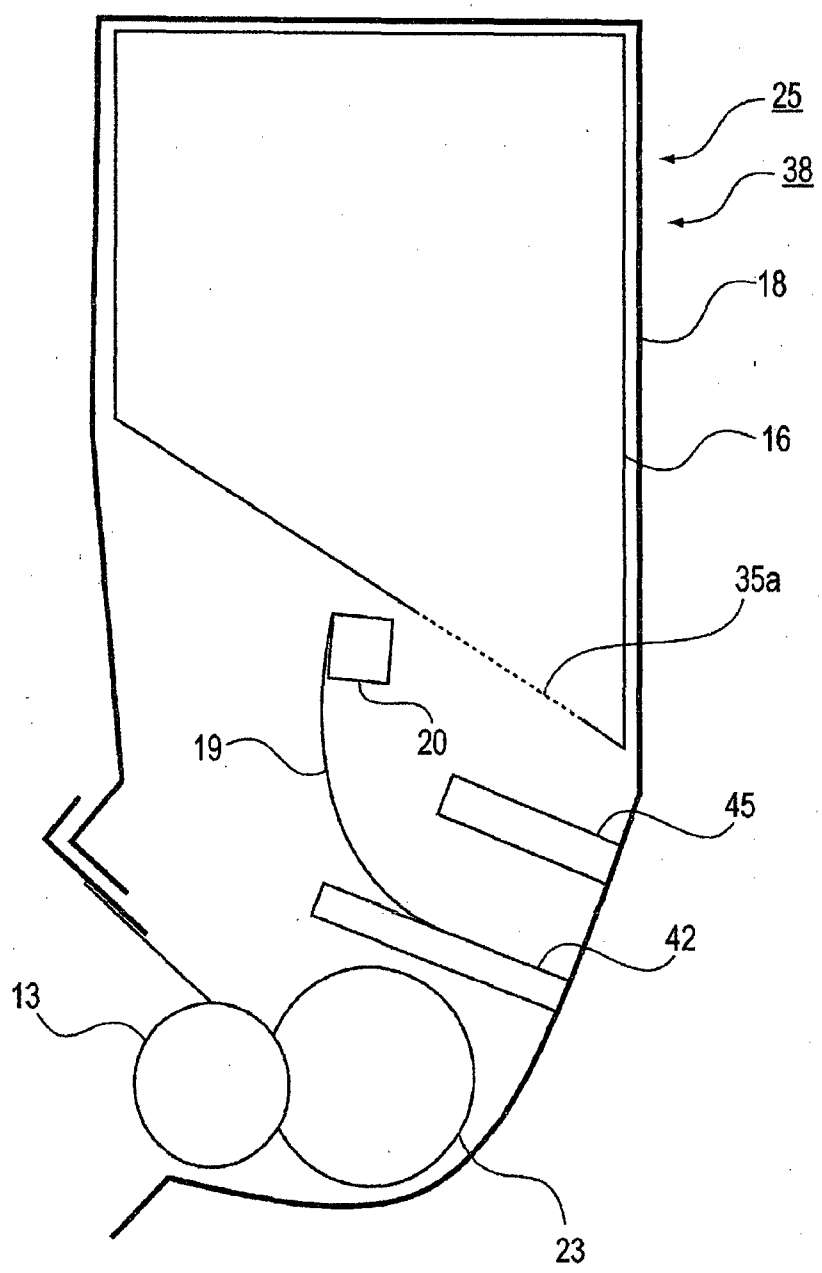

Fig. 53

Canon Kabushiki Kaisha
Applicant

By:

C. RISEL G. CASTILLO-TALEON

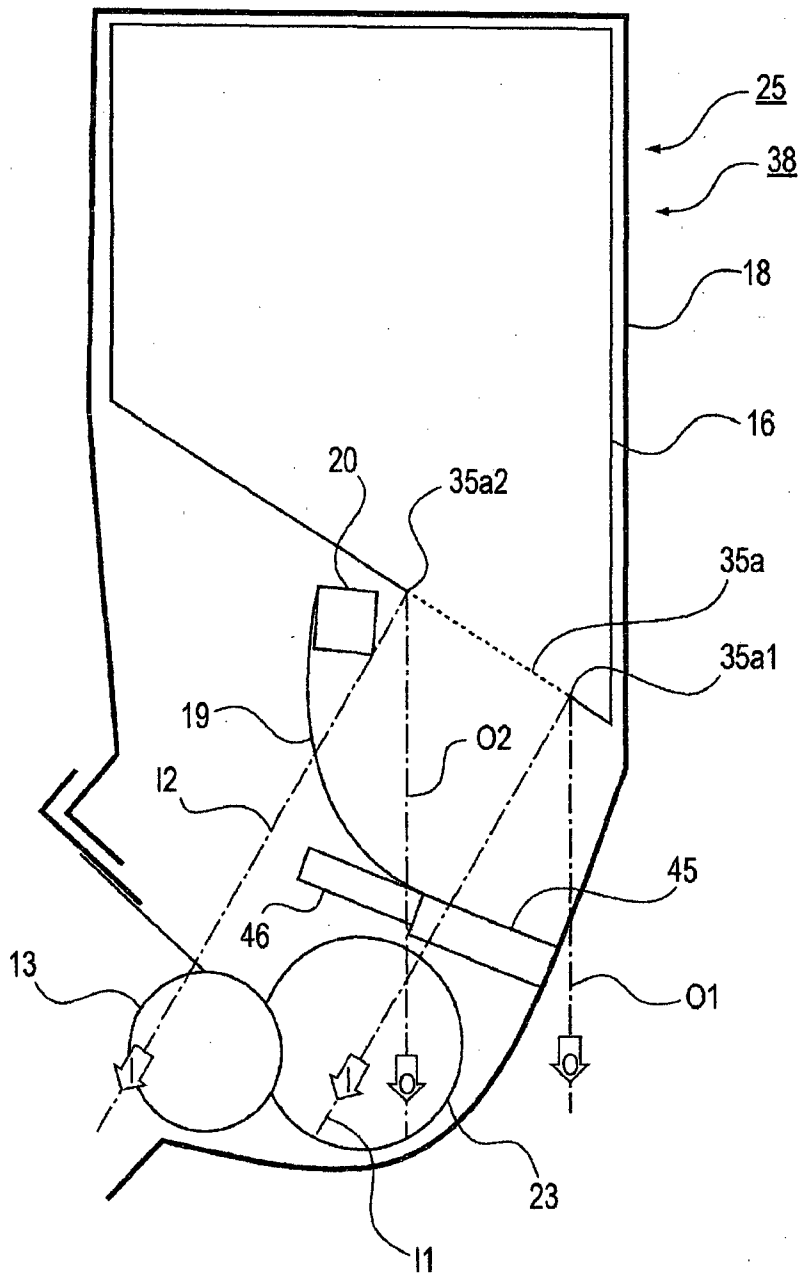

Fig. 54

Canon Kabushiki Kaisha
Applicant

By:

C. RISEL G. CASTILLO-TALEON

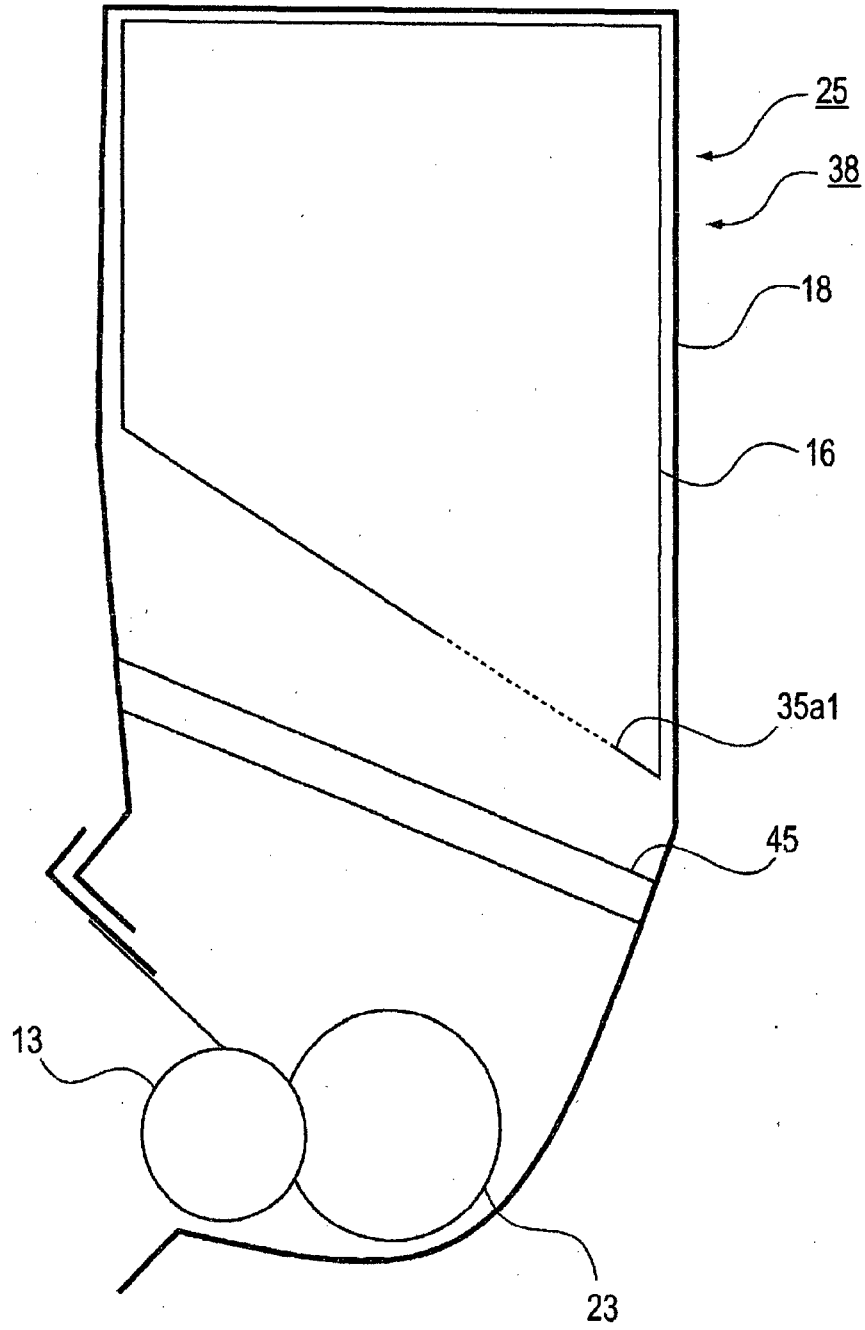

Fig. 55

Canon Kabushiki Kaisha
Applicant

By:

C. RISEL G. CASTILLO-TALEON

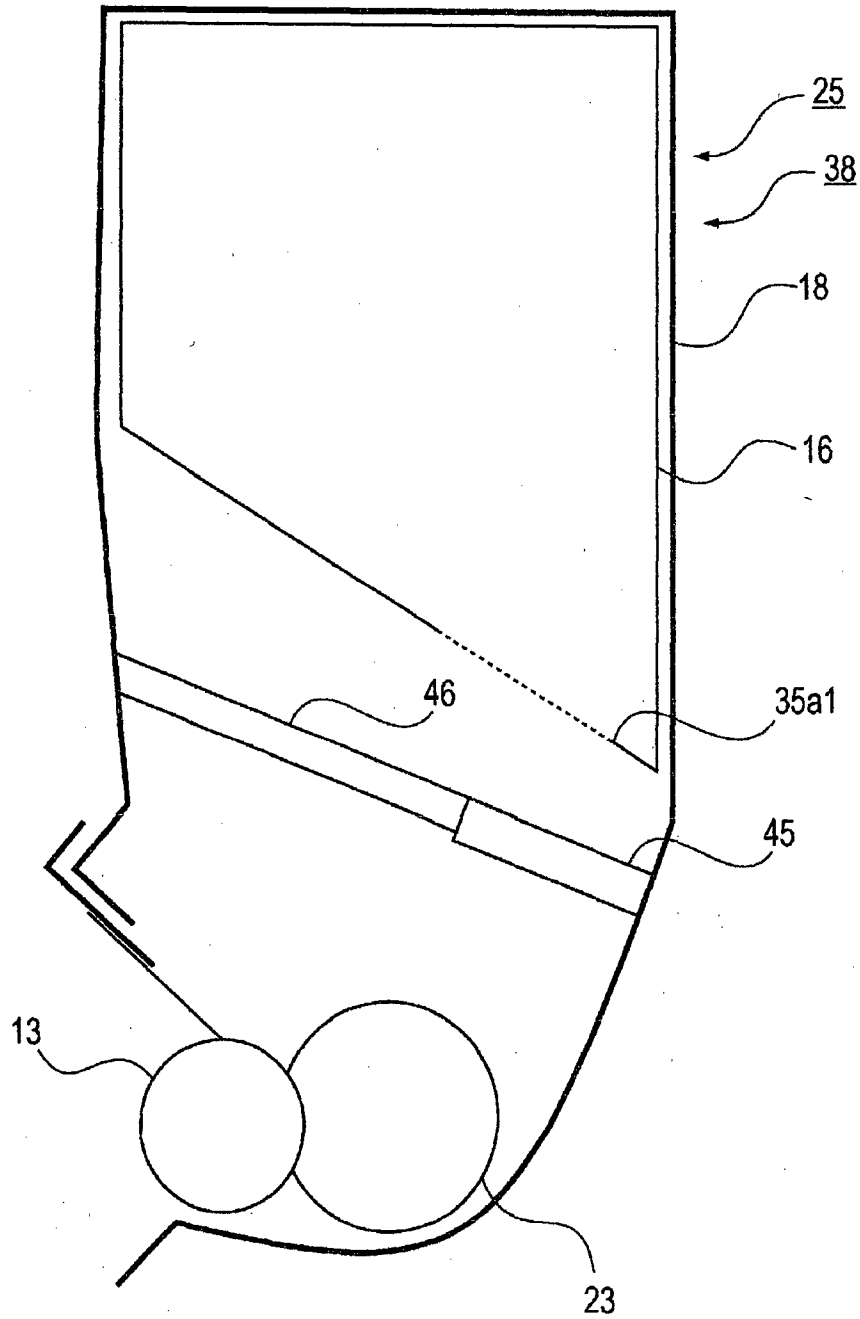

Fig. 56

Canon Kabushiki Kaisha
Applicant

By:

C. RISEL G. CASTILLO-TALEON

INTELLECTUAL PROPERTY OFFICE
RECEIVED

2017 MAY 12 PM 4:16

06/09/2018 10:03 04772

(a)

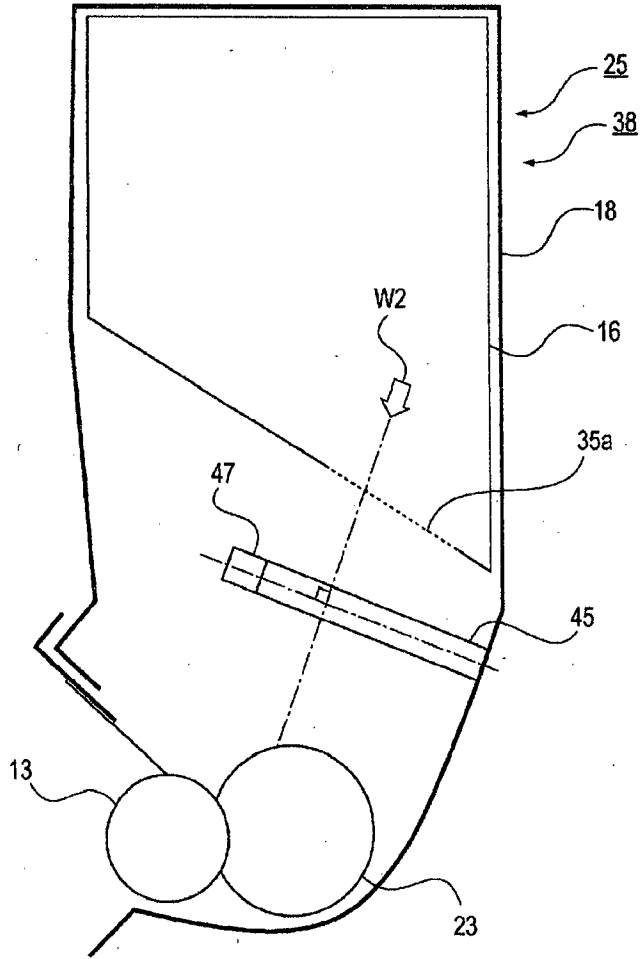

(b)

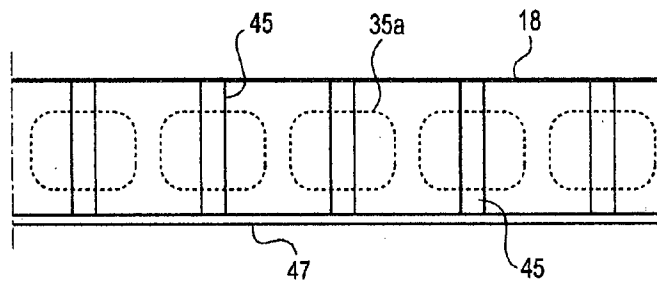

Fig. 57

Canon Kabushiki Kaisha
Applicant

By:

C. RISEL G. CASTILLO-TALEON

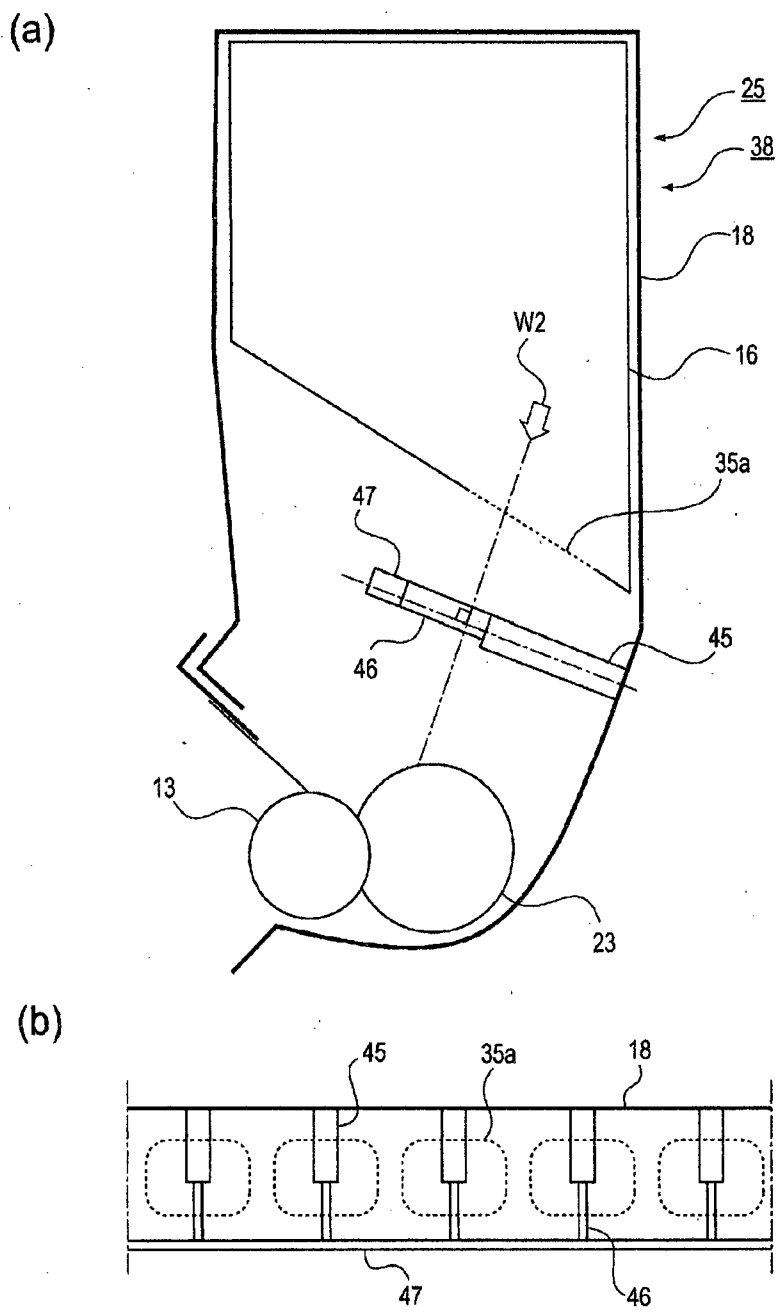

Fig. 58

Canon Kabushiki Kaisha
Applicant

By: 
C. RISEL G. CASTILLO-TALEON