

(19)  
(12)

(KR)  
(A)

(51) 。 Int. Cl. <sup>7</sup>  
H01L 21/28

(11)  
(43)

2001 - 0063853  
2001 07 09

(21) 10 - 1999 - 0061957  
(22) 1999 12 24

(71) 136 - 1

(72) 2 92

(74) :

(54)

가

1 1 가 1

2 2,1 ,

2 2 2 1 2 2 2

가 .

1e



2  
 2  
 가  
 가  
 1 1 가  
 1  
 2  
 2,1  
 1  
 2 2  
 2 2  
 2 2 2  
 1a 1e  
 (11) (13) 1 (13), 1 (15)  
 (13) (15)  
 1 (15)

, 1 (17) . , 1 (17)

, 1 (19) . . . . ( boro phospho silicate glass, BPSG )

, BPSG

, 1 (19) (21) .

, (21) .

, (19) ( ) (21) 1

, 2 (25) .

, (11) ( ) 2 (25) 1 (19)  
(23)

, (21) 1 (19) (19) (21)  
1 (19) . ( 1a)

, (23) 1 (27) .

, 1 (27) / .

, (21) 1 (27)

, Cl F 가 1  
(27) . ( 1b)

, (21) 2 (25) 2 (29) .

, 2 (29)  
.( 1c)

) , 2 (29) 2 (31) , 2 (29)  
1/5 3/5 2 (31)

, 2 (31) 가  
.( 1d)

, 2 (29) 2 (33) .

, 2 (33) 2 (29) 2 (25) ,  
2 (29)

, 2 (33) SAC . ( 1e)

가  
가

가

(57)

1.

1 1 가 ,

1 ,

2 ,

2,1

1 ,

2 2 ,

2 2 ,

2 2 2

2.

1 ,

3.

1 ,

2,1 C-F 가

4.

3 ,

2,1  
F<sub>8</sub>, C<sub>4</sub>F<sub>8</sub>, C<sub>5</sub>F<sub>8</sub>

C<sub>4</sub>F<sub>6</sub>

C/F 가

가

C<sub>2</sub>F<sub>6</sub>, C<sub>3</sub>

5.

3 ,

2,1  
가 C-H-F 가

가

가

CH<sub>3</sub>F, CH<sub>2</sub>F<sub>2</sub>, C<sub>2</sub>HF<sub>5</sub>

C<sub>3</sub>H<sub>2</sub>F<sub>6</sub>

6.

3 ,

2,1

가

가

7.

1 ,

1

/

8.

1 ,

1,2

9.

1 ,

1

Cl F 가

10.

1 ,

1,2

11.

1 ,  
1,2  
.

1a

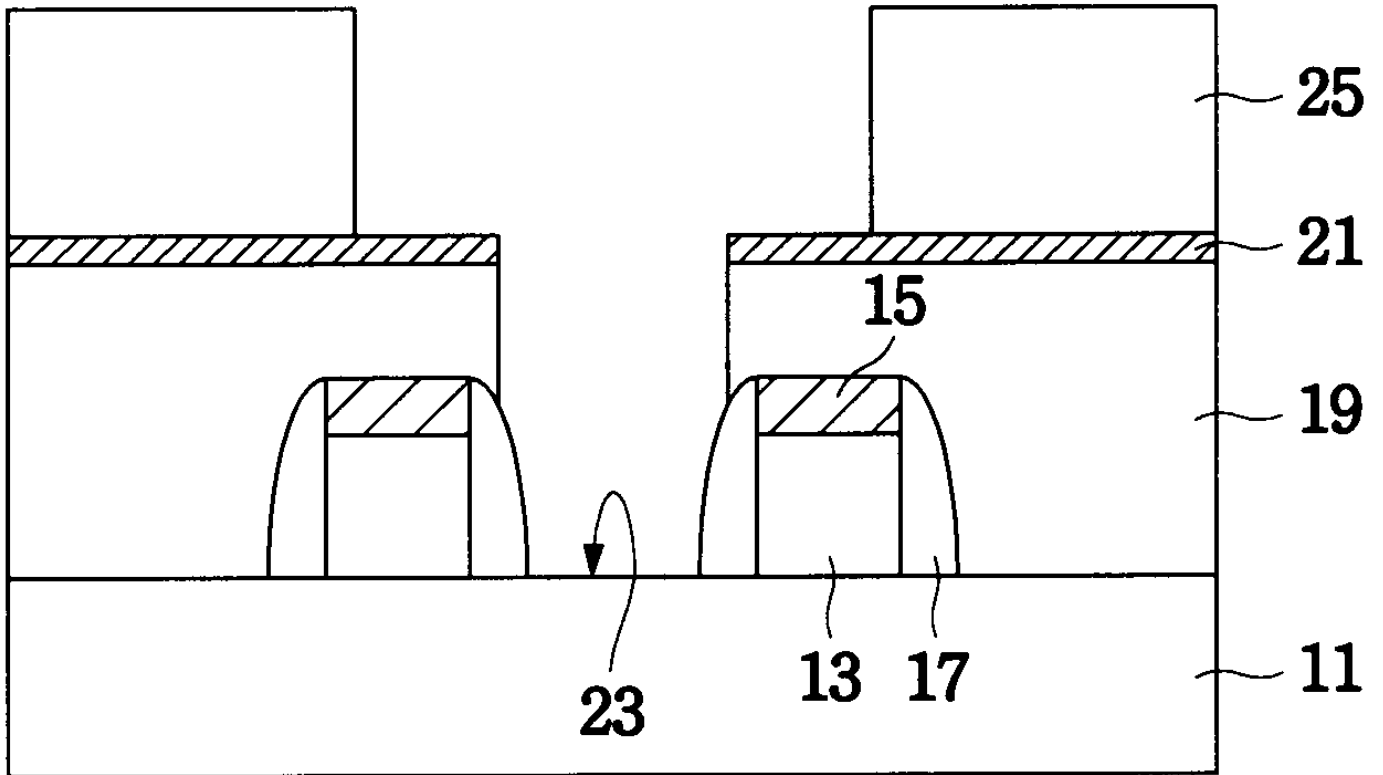

1b

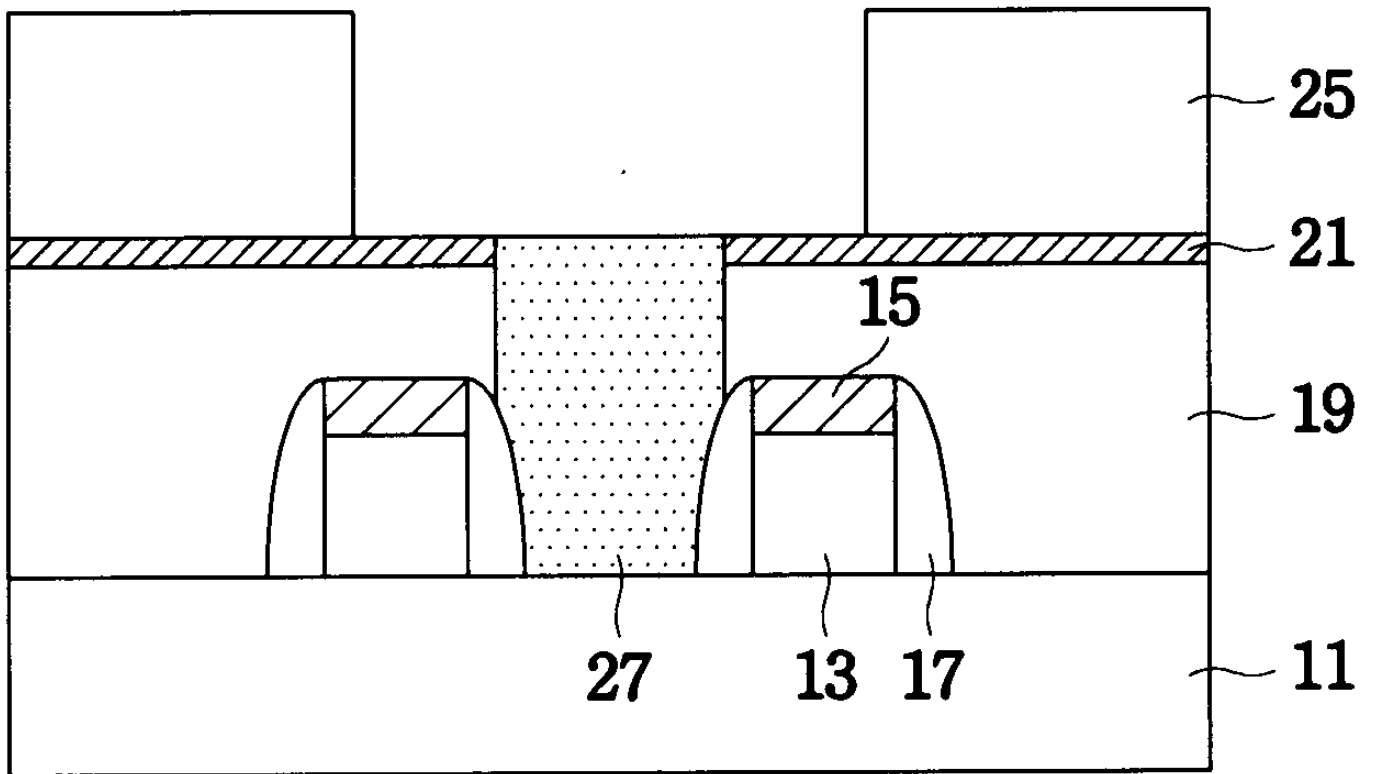

1c

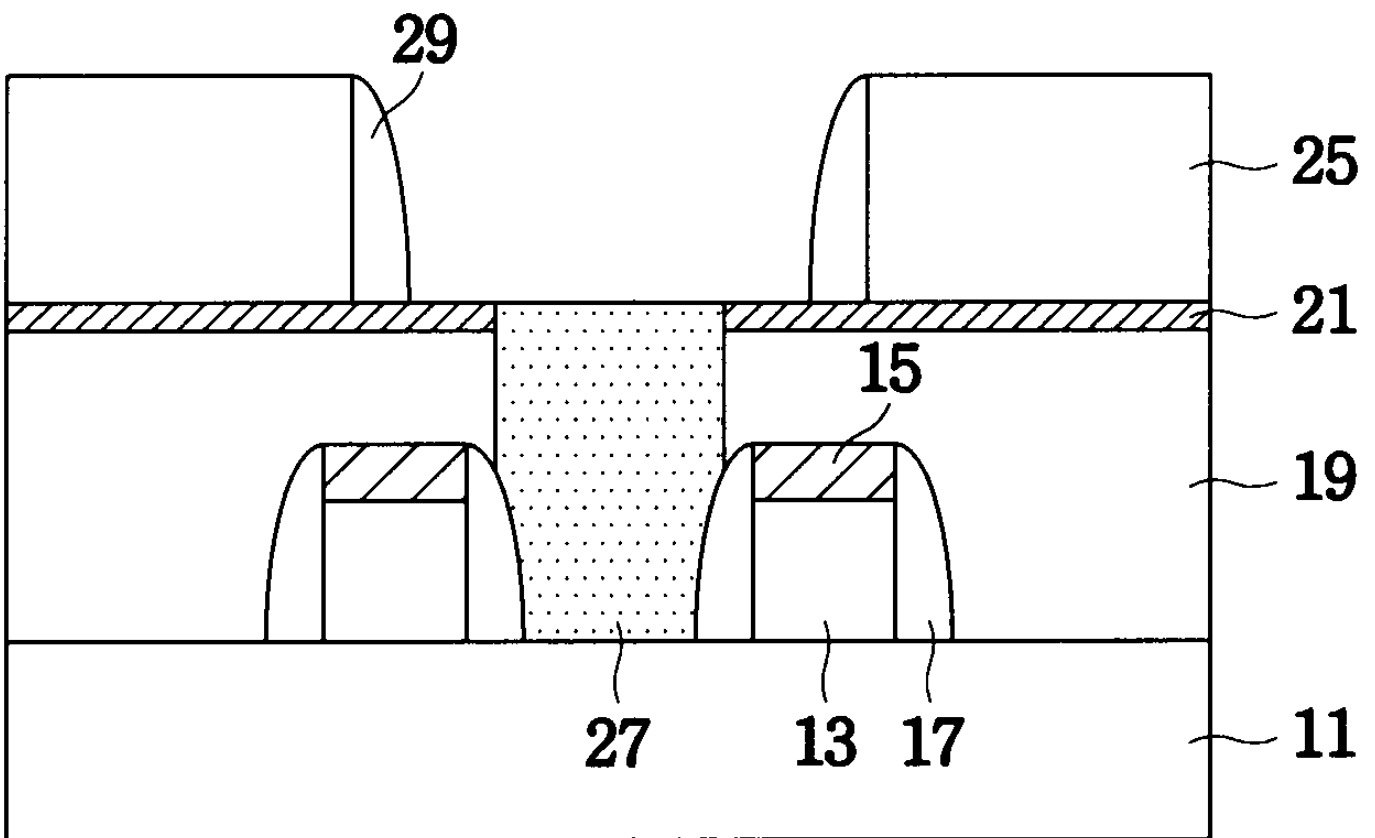

1d

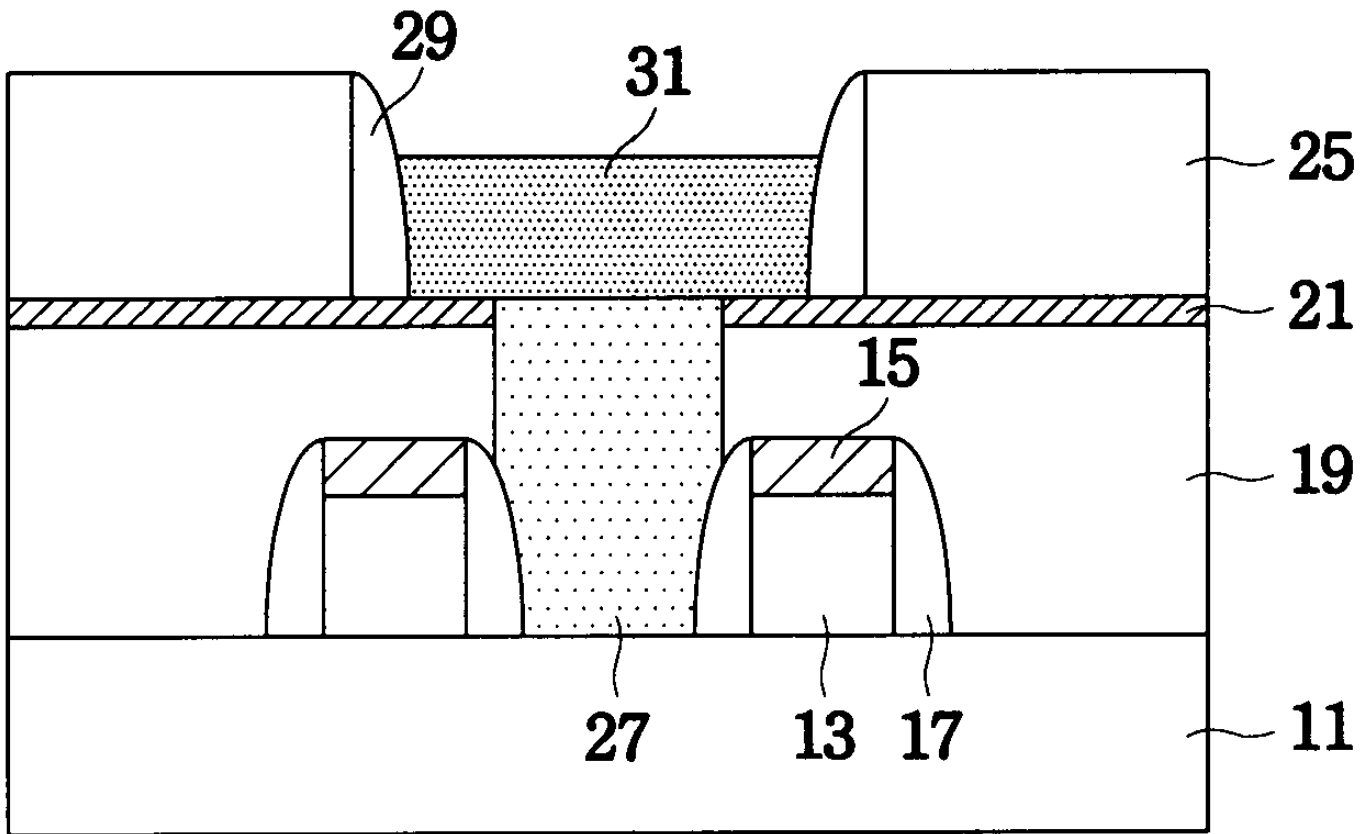

1e

