

(19)



Europäisches Patentamt
European Patent Office
Office européen des brevets



(11)

EP 0 709 868 B1

(12)

EUROPEAN PATENT SPECIFICATION

(45) Date of publication and mention of the grant of the patent:
08.04.1998 Bulletin 1998/15

(51) Int Cl.⁶: **H01H 73/04**

(21) Application number: **94119681.8**

(22) Date of filing: **13.12.1994**

(54) **Circuit breaker**

Leistungsschalter

Disjoncteur

(84) Designated Contracting States:
DE FR GB NL

(30) Priority: **30.08.1994 JP 205117/94**

(43) Date of publication of application:
01.05.1996 Bulletin 1996/18

(73) Proprietor: **mitsubishi denki kabushiki kaisha**
Tokyo 100 (JP)

(72) Inventors:
• **Iio, Tsukasa, c/o Mitsubishi Denki K. K. Fukuyama-shi, Hiroshima 720 (JP)**
• **Fujiwara, Kohei, c/o Mitsubishi Denki K. K. Fukuyama-shi, Hiroshima 720 (JP)**

• **Matsumoto, Shuuji, c/o Mitsubishi Denki K. K. Fukuyama-shi, Hiroshima 720 (JP)**
• **Terasawa, Masami, c/o Mitsubishi Denki K. K. Fukuyama-shi, Hiroshima 720 (JP)**
• **Matsumoto, Shigeru c/o Mitsubishi El. Eng. Co Ltd. Fukuyama-shi Hiroshima 720 (JP)**

(74) Representative: **KUHNEN, WACKER & PARTNER**
Alois-Steinecker-Strasse 22
85354 Freising (DE)

(56) References cited:
WO-A-93/22784 DE-A- 2 002 934
DE-C- 1 138 139 GB-A- 207 363
US-A- 3 286 071 US-A- 3 464 040

EP 0 709 868 B1

Note: Within nine months from the publication of the mention of the grant of the European patent, any person may give notice to the European Patent Office of opposition to the European patent granted. Notice of opposition shall be filed in a written reasoned statement. It shall not be deemed to have been filed until the opposition fee has been paid. (Art. 99(1) European Patent Convention).

Description

BACKGROUND OF THE INVENTION

a) Field of the Invention

This invention relates to a molded-case circuit breaker, and more particularly to an improvement of the movable member in the circuit breaker which is operated to open and close the circuit.

b) Description of the Related Art

FIGS. 8 through 10 shows a conventional circuit breaker disclosed by, for instance, Japanese Utility Patent Publication No. 32922/1993. FIG. 8 is a side view of the circuit breaker which is tripped, and FIG. 9 is a side view of the latter which is in "on" state (the circuit being closed). In those figures, reference numeral 1 designates a casing of synthetic resin comprising a cover 1a and a base 1b; 2, a stationary member provided on the bottom of the base 1b, the stationary member 2 having a stationary contact 2a; 3, a frame secured to the base 1b of the casing 1 with screws 4; 5, an operating handle which is swingable about a protrusion 3a formed on the frame 3; 6, a cradle rotatably mounted on the operating handle 5; 7, an upper link pin; and 8, a link mechanism comprising an upper link 8a and a lower link 8b which are coupled to each other through a coupling pin 9. Further in FIGS. 8 and 9, reference numeral 10 designates a pulling spring which urges the coupling pin 9 towards the operating handle 5 to lock the upper link 8a to the upper link pin 7; 11, a cross bar which is rotatably provided with respect to the base 1b, the cross bar being coupled to the lower link 8b through a lower link pin 12; and 13, a movable member having a movable contact 13a, the movable member 13 being rotatably mounted on a movable member shaft 14 embedded in the cross bar 11.

In FIG. 9, reference numeral 15 denotes a stationary conductor secured to the base 1b; 16, a flexible conductor connected between the stationary conductor 15 and the movable member 13; 17, an instantaneous tripping electromagnetic device mounted on the base 1b, having a movable iron core 17a; 18, a timed tripping bimetal device; 18a, an adjusting screw for adjusting the tripping operation; 19, a trip bar which is engaged with the movable iron core 17a and the adjusting screw 18a; 20, a hook which is engaged with the trip bar 19; and 21, a latch adapted to engage with the hook 20, with the cradle 6 being engaged with the latch 21. Further in FIG. 9, reference numeral 22 designates a stopper pin on the frame 3; 23, a link stopper adapted to abut against the stopper pin 22, the link stopper 23 having an abutment portion 23a with which the upper link 8a is elastically brought into contact when tripped; and 24, a conventional de-ionization arc extinguish chamber.

For the above-described circuit breaker, a variety of

movable members may be employed. FIG. 10 shows an example of the movable member which is made up of a flat-plate-shaped movable conductor 13b, and a movable contact 13a blazed to one surface of the conductor 13b which corresponds to the thickness of the latter 13b. FIG. 11 shows a movable member 13 disclosed by Japanese Utility Patent Application (OPI) No. 41348/1990 (the term "OPI" as used herein means an "unexamined application"), which is coupled to the base 1b. The movable member 13 is also made up of a flat-plate-shaped movable conductor 13b, and a movable contact 13a which is blazed to one surface of the movable conductor 13b which corresponds to the width of the latter 13b. FIG. 12 shows another example of the flat-plate-shaped movable member, which is formed as follows: One end portion of a flat-plate-shaped arm 13b is bent L-shaped to form a flat ear, and a movable contact 13a is blazed to the flat ear thus formed. The arm 13b has a hole 14a into which the movable member shaft is inserted. FIG. 13 is a plan view outlining the arrangement of a plurality of the movable members 13 shown in FIG. 12 which are built in a multi-pole circuit breaker. The centers of the movable contacts 13a and those of the stationary contacts 2a are shifted as much as L from the positions on the common movable member shaft 14 where the movable members 13 are supported by the latter 14.

The operations of the circuit breaker thus organized, such as the on-off operation with the operating handle 5 and the tripping operation by the electromagnetic device 7 or the bimetal device 18 when large current flows in the circuit, are as disclosed by the aforementioned Japanese Utility Patent Publication No. 32922/1993.

In the conventional circuit breaker as described above, the movable member 13 which, as shown in FIG. 10, is formed by blazing the movable contact 13a to the surface of the flat-plate-shaped movable conductor 13b which corresponds to the thickness of the latter 13b, suffers from the following difficulties: The flat-plate-shaped movable conductor 13b is reduced in mechanical strength by blazing heat. On the other hand, depending on the thickness of the movable conductor 13b, the blazing area of the movable contact 13a is small, so that the movable contact welded to the movable conductor is not sufficiently secured thereto. In addition, for the same reason, the heat generated in the movable contact 13a by current is not readily conducted to the movable conductor 13a, so that the movable contact 13a is liable to become high in temperature. On the other hand, the blazing work is liable to be fluctuated in welding pressure, in welding current, in welding time, and therefore the resultant weld is not stable in mechanical strength. Hence, the blazing work takes time and labor, which increases the manufacturing cost.

The movable member made up of the flat-plate-shaped movable conductor 13b as shown in FIG. 11 is advantageous as follows: Since the movable conductor 13b is relatively large in width, the movable contact 13a

can be blazed to the conductor 13b with ease, or it may be joined to the latter 13b by caulking. In addition, the elasticity of the movable conductor 13b enhances the operation of the latter 13b and that of a link mechanism (not shown). However, the movable member suffers from the following difficulty: Since the slit 1d is large in correspondence to the large width of the movable conductor 13b, arc gas produced at the contact when the circuit is opened is liable to flow through the slit 1d to the tripping device (17 and 18 in FIG. 9).

On the other hand, the movable member shown in FIG. 12, which comprises; the flat-plate-shaped movable conductor 13b whose one end portion is bent L-shaped to form the flat ear; and movable contact 13a blazed to the flat ear thus formed, is also disadvantageous in the following points: The movable contact 13a is liable to be shifted as shown in FIG. 13. In other words, the centers of the movable contacts 13a are shifted as much as L to the left from the central lines of the flat-plate-shaped conductors 13b, respectively, which are supported on the movable member shaft 14. Accordingly, the center of each of the movable contacts 13a is shifted by L to the left from the center of the casing 1. This shift makes the positional relationship between the stationary contact 2a and the movable contact 13a liable to change, and increases the external dimensions of the circuit breaker depending on its structure.

From DE-A-2 002 934 there is known a circuit breaker, comprising:

a stationary member having a stationary contact on one end portion thereof, said stationary member being provided on the side of the bottom of a casing ;
 a movable member including a first and a second plate-shaped portion so that said plate-shaped portions are arranged in a 90° angle to each other, said first plate-shaped portion having a movable contact which is fixed to its end in such a way that said movable contact is opposed to said stationary contact ;
 and
 a cross bar which supports the end of said second plate-shaped portion and is coupled to a switching mechanism, and which is adapted to operate said movable member so that said movable contact is moved into and out of engagement with said stationary contact.

From DE-A-2 002 934 there is also known a movable member adapted to be installed in a circuit breaker to open and close a circuit in cooperation with a stationary member having a stationary contact, said movable member comprising:

a first plate-shaped portion on which a movable contact is provided; and
 a second plate-shaped portion oriented at 90° with respect to said first plate-shaped portion and wherein said movable contact is fixed to the end of

said first plate-shaped portion.

SUMMARY OF THE INVENTION

5 Accordingly, an object of this invention is to eliminate the above-described difficulties accompanying a conventional circuit breaker. More specifically, a first object of the invention is to provide a circuit breaker in which its movable member made up of a movable conductor such as a thin metal plate is sufficiently high in mechanical strength, and the movable contact welded to the movable conductor is positively secured to the latter, showing high weld strength, and which is low in manufacturing cost when compared with the conventional one. A second object of the invention is to provide a circuit breaker in which arc gas produced at the contact when the circuit is opened scarcely flows to the tripping device (17 and 18 in FIG. 9).

10 The foregoing object of the invention has been achieved by the provision of a circuit breaker according to claims 1 and 3 and a movable member according to claim 5.

15 In the circuit breaker, the movable member may be so modified that it is formed by forging a metal material to include first and second plate-shaped portions which form 90° with each other, and a movable contact is provided on the first plate-shaped portion at the end in such a manner that it is confronted with the stationary contact.

20 Furthermore, in the circuit breaker, a portion of the movable conductor which is next to the first plate-shaped portion on which the movable contact is formed may be curved inwardly with respect to the first plate-shaped portion, thus providing a step.

25 Moreover, in the circuit breaker, the movable member may be so modified that it includes: an L-shaped plate material having a protrusion at one end which is bent 90°; and a movable contact provided on the protrusion thus bent in such a manner that the movable contact is confronted with the stationary contact, and the center of the movable contact is on the central line of the movable member.

30 In addition, in the circuit breaker, the synthetic resin casing may have a partition wall having a slit which is engaged with the portion of the movable conductor 13b which is made perpendicular to the bottom of the casing and is located between the movable contact of the movable member and the cross bar, the slit being made as small in width as permitting the movement of the movable member therein.

35 In the circuit breaker designed as described above, one end portion of the movable conductor made of a metal plate is formed into a first plate-shaped portion having a predetermined width on which the movable contact is provided, and the movable conductor is twisted 90° at the middle so that the remaining portion is perpendicular to the bottom of the casing. The movable member thus formed is sufficiently high in mechanism strength, and the movable contact welded to the mov-
 40
 45
 50
 55

ble conductor is positively secured to the latter.

In the circuit breaker, the movable member is so modified that it is formed by forging a metal material and includes the first and second plate-shaped portions which form 90° with each other. The movable member thus formed is also sufficiently high in mechanical strength, and the movable contact welded to the movable conductor is positively secured to the latter.

Furthermore, in the circuit breaker, as was described above the portion of the movable conductor which is next to the first plate-shaped portion, on which the movable contact is provided, is curved inwardly with respect to the first plate-shaped portion to form the step. The step thus formed protects the movable conductor from arc gas produced at the contact.

Moreover, in the circuit breaker, the movable member is so modified that it includes: the L-shaped plate material having the protrusion at one end which is bent 90°; and the movable contact provided on the protrusion thus bent in such a manner that the movable contact is confronted with the stationary contact, and the center of the movable contact is on the central line of the movable member. Hence, the movable member is simple in design and high in mechanical strength, and the movable contact welded to the movable conductor is positively secured to the latter.

In addition, in the circuit breaker, the synthetic resin casing has the partition wall with the slit which is engaged with the portion of the movable conductor which is made perpendicular to the bottom of the casing and is located between the movable contact of the movable member and the cross bar; and the slit is limited in width to the extent that the movable member is movable therein. The partition wall prevents arc gas produced at the contact from flowing to the tripping device.

BRIEF DESCRIPTION OF THE DRAWINGS

FIG. 1 is a side view, with parts cut away, showing a circuit breaker which is tripped, which constitutes a first embodiment of the invention.

FIG. 2 is a side view, with parts cut away, showing the circuit breaker which is in "on" state.

FIG. 3 is a perspective view of an example of a movable member in the circuit breaker according to the invention.

FIG. 4 is a perspective view of another example of the movable member in the circuit breaker.

FIG. 5 is a perspective view showing a movable member in a circuit breaker, which constitutes a second embodiment of the invention.

FIG. 6(A) is a front view showing a movable member in a circuit breaker, which constitutes a third embodiment of the invention, and FIG. 6(B) is a side view thereof.

FIG. 7 is a perspective view of a movable member and its relevant component in a circuit breaker, which constitutes a fourth embodiment of the invention.

FIG. 8 is a side view of a conventional circuit breaker which is tripped.

FIG. 9 is a side views of the conventional circuit breaker which is in "on" state.

FIGS. 10 through 12 are perspective views showing examples of a movable member in the conventional circuit breaker.

FIG. 13 is an explanatory diagram showing a plurality of the movable members shown in FIG. 12 which are applied to a multi-pole circuit breaker.

DETAILED DESCRIPTION OF THE PREFERRED EMBODIMENTS

15 First Embodiment

FIGS. 1 and 2 show a circuit breaker with a part of its molded casing cut away, which constitutes a first embodiment of the invention. More specifically, FIG. 1 is a side view of the circuit breaker which is tripped, and FIG. 2 is a side view of the latter which is in "on" state (the circuit being closed). In the circuit breaker, the components except a base 1b and a movable member 13 are equal to those in the above-described conventional circuit breaker, and are therefore designated by the same reference numerals or characters in FIGS. 1 and 2. In addition, in the base 1b and the movable member 13, parts corresponding functionally to those in the conventional circuit breaker are designated by the same reference numerals or characters.

FIG. 3 shows an example of the movable member 13 in the first embodiment of the invention. In FIG. 3, reference character 13b designates a movable conductor fabricated from a conductive metal plate such as a copper plate or brass plate. The movable conductor 13b has a movable contact 13a on its one end portion. The one end portion of the movable conductor 13b is formed into a plate-shaped portion 13d larger in width than the diameter of the movable contact 13a. A movable contact mounting hole 13c is formed in the plate-shaped portion 13d, so that the movable contact 13a is fixedly secured to the plate-shaped portion 13d by caulking. The middle portion 13e of the movable conductor 13b is twisted through 90° so that the remaining portion of the movable conductor 13b is perpendicular to the bottom 1c of the base 1b. In FIG. 3, reference numeral 14 denotes a movable member shaft; and 14a, a rotary shaft hole into which the movable member shaft 14 is inserted. The movable member 13 thus formed is rotatably held through the movable member shaft 14 on the cross bar 11 (shown in FIG. 1).

The portion of the movable conductor 13b which is next to the plate-shaped portion 13d is curved inwardly with respect to the latter 13d, to form a step 13f. In the above-described embodiment, the movable contact 13a is fixedly secured to the movable conductor 13b; however, the invention is not limited thereto or thereby. For instance, as shown in FIG. 4, a round or square movable

contact may be secured to it by blazing.

Second Embodiment

In the above-described first embodiment, the movable conductor 13b is made of a metal plate. However, as shown in FIG. 5, it may be formed by forging copper material or brass material. That is, in the second embodiment, the movable conductor 13b is formed by cold forging so that it comprises: a plate-shaped portion 13d at one end which has a predetermined width in correspondence to the size of the movable contact 13a; and the remaining portion which is also in the form of a plate which has a thickness smaller than the predetermined width of the plate-shaped portion 13d. The remaining portion is oriented at 90° with respect to the plate-shaped portion 13d so that it is perpendicular to the bottom of the base 1b. In FIG. 5, reference character 13f designates a step; and 14a, a rotary shaft hole. The movable member whose movable conductor 13b is formed by forging in the above-described manner has the same effects as the movable member made of a metal plate in the first embodiment.

Third Embodiment

In the above-described first embodiment, the middle portion of the movable conductor 13b is twisted through 90° so that one end portion of the movable conductor 13b is provided as the plate-shaped portion on which the movable contact 13a is formed, and the remaining portion is perpendicular to the bottom of the base 1b. Instead of the movable member in the first embodiment, a movable member formed as shown in FIG. 6 may be employed with the same effects. That is, in the third embodiment, the movable member 13 is formed by bending a plate material. FIGS. 6(A) and 6(B) are a plan view and a side view of the movable member 13, respectively. As shown in FIGS. 6(A) and 6(B), a movable conductor 13b for forming the movable member 13 is made of an L-shaped plate whose one end portion is formed into a plate-shaped portion 13d having a predetermined width, on which a movable contact 13a is formed. The plate-shaped portion 13d is bent through 90° so that the remaining portion is perpendicular to the bottom of the base 1b. And the middle portion of the movable conductor 13b is so bent that the center of the movable contact 13a is on the central line of the movable member 13.

Fourth Embodiment

In a fourth embodiment of the invention, the casing 1 has a partition wall with a slit. The slit is engaged with the portion of the movable conductor 13b which is made perpendicular to the bottom of the base 1b and is located between the movable contact 13a of the movable member 13 and the cross bar 11. This structure eliminates

the adverse effect of the arc gas produced at the contact. The partition wall is as indicated at 1e in FIG. 7. The partition wall 1e has the slit 1d which is made as small in width as permitting the movement of the movable member 13 (in the directions of the arrow A) in the slit. The partition wall 1e prevents the arc gas g produced at the contact from flowing to the tripping device (17 and 18 in FIG. 9).

The circuit breaker, which is designed as described above, has the following effects or merits:

In the circuit breaker constituting the first embodiment, one end portion of the movable conductor made is formed into the first plate-shaped portion having the predetermined width on which the movable contact is provided, and the movable conductor is twisted 90° at the middle so that the other end portion is perpendicular to the bottom of the casing. This structure increases the mechanical strength of the supporting portion of the movable member during switching, and enhances the welding of the movable contact. Thus, the movable contact welded to the movable conductor is positively secured to the latter, and the movable member can be pivotally supported with ease.

In the second embodiment, the movable member is formed by forging a metal material to include the first and second plate-shaped portions which form 90° with each other. The movable member thus formed is also sufficiently high in mechanical strength, and the movable contact welded to the movable conductor is positively secured to the latter.

Furthermore, in the circuit breaker, the movable conductor has the portion which is next to the first plate-shaped portion on which the movable contact is provided, and is curved inwardly with respect to the first plate-shaped portion to form the step. The step thus formed protects the movable conductor from the arc gas produced at the contact.

In the third embodiment, the movable member is made up of the L-shaped plate material having the protrusion at one end which is bent 90°. The movable member thus formed is simple in design, and high in mechanical strength, and the movable contact welded to the movable conductor is positively secured to the latter.

In the fourth embodiment, the synthetic resin casing has the partition wall with the slit which is engaged with the portion of the movable conductor which is made perpendicular to the bottom of the casing and is located between the movable contact of the movable member and the cross bar, and the slit is limited in width to the extent that the movable member is movable therein. The partition wall prevents the arc gas produced at the contact from flowing to the tripping device.

55 **Claims**

1. Circuit breaker, comprising:

a stationary member (2) having a stationary contact (2a) on one end portion thereof, said stationary member (2) being provided on the side of the bottom (1b) of a synthetic resin casing (1);

a movable member (13) including a first and a second plate-shaped portion (13d, 13b) which are formed either by twisting the middle portion (13e) of a metal plate or by forging a metal material so that said plate-shaped portions (13d, 13b) are arranged in a 90° angle to each other, said first plate-shaped portion (13d) having a movable contact (13a) which is fixed to its end by caulking in such a way that said movable contact (13a) is opposed to said stationary contact (2a) the first and second plate-shaped portions (13d, 13b) are formed in such a way that the center of said movable contact (13a) is on the central line of said movable member (13) and

a cross bar (11) which supports the end of said second plate-shaped portion (13b) and is coupled to a switching mechanism (8), and which is adapted to operate said movable member (13) so that said movable contact (13a) is moved into and out of engagement with said stationary contact (2a).

2. Circuit breaker according to claim 1, *characterized in that* said movable member (13) has a portion which is next to said first plate-shaped portion (13d) on which said movable contact (13a) is formed, and is curved inwardly with respect to said first plate-shaped portion (13d), thus providing a step (13f).

3. Circuit breaker, comprising:

a stationary member (2) having a stationary contact (2a) on one end portion thereof, said stationary member (2) being provided on the side of the bottom (1b) of a synthetic resin casing (1);

a movable member (13) including an L-shaped plate material having a protrusion at one end which is bent by 90°, a movable contact (13a) being provided on said protrusion by caulking, the plate material being bent in such a way that said movable contact (13a) is opposed to said stationary contact (2a) and the center of said movable contact (13a) is on the central line of said movable member (13); and

a cross bar (11) which supports the end of said second plate-shaped portion (13b) and is coupled to a switching mechanism (8), and which is adapted to operate said movable member (13) so that said movable contact (13a) is moved into and out of engagement with said stationary contact (2a).

4. Circuit breaker according to one of the preceding claims, *characterized in that* said synthetic resin casing (1) has a partition wall (1e) having a slit (1d) which is engaged with the portion of said movable member (13) which is made perpendicular to the bottom of said casing (1) and is located between said movable contact (13a) of said movable member (13) and said cross bar (11), the width of said slit (1d) being selected such said movable member (13) is able to move therein.

5. Movable member (13) adapted to be installed in a circuit breaker to open and close a circuit in cooperation with a stationary member (2) having a stationary contact (2a), said movable member (13) comprising:

a first plate-shaped portion (13d) on which a movable contact (13a) is provided; and

a second plate-shaped portion (13b) oriented at 90° with respect to said first plate-shaped portion (13d), said second plate-shaped portion (13b) defining a center line;

wherein said first and second plate-shaped portions (13d, 13b) are integrally connected to each other in such a way that a center of said movable contact (13a) is substantially located on said center line; and

wherein said movable contact (13a) is fixed to the end of said first plate-shaped portion (13d) by caulking.

6. Movable member according to claim 5, *characterized in that* said movable member (13) is formed by twisting the middle portion (13e) of a metal plate, which portion is located between said first and second plate-shaped portions (13d, 13b).

7. Movable member according to claim 5, *characterized in that* said movable member (13) is formed by forging a metal material.

8. Movable member according to claim 5, *characterized in that* said second plate-shaped portion (13d) includes a first section defining said center line, a second section parallel to said first section and displaced from said center line, and a third section integrally connecting said first section to said second section, wherein said first plate-shaped portion (13b) is integrally connected to said second section.

9. Movable member according to claim 8, *characterized in that* said movable member (13) is formed from a L-shaped metal plate.

Patentansprüche

1. Schutzschalter, der aufweist:

ein feststehendes Teil (2), das einen feststehenden Kontakt (2a) auf einem Endabschnitt von ihm aufweist, wobei das feststehende Teil (2) auf der Seite des Bodens (1b) eines Gehäuses (1) aus synthetischem Harz vorgesehen ist;

ein bewegliches Teil (13), das einen ersten und einen zweiten plattenförmigen Abschnitt (13d, 13b) beinhaltet, welche entweder durch derartiges Verdrehen des Mittenabschnitts (13e) einer Metallplatte oder durch derartiges Hämmern eines Metallmaterials ausgebildet sind, daß die plattenförmigen Abschnitte (13d, 13b) zueinander in einem Winkel von 90° angeordnet sind, wobei der erste plattenförmige Abschnitt (13d) einen beweglichen Kontakt (13a) aufweist, welcher durch Verstemmen auf eine derartige Weise an seinem Ende befestigt ist, daß der bewegliche Kontakt (13a) dem feststehenden Kontakt (2a) gegenüberliegt, wobei die ersten und zweiten plattenförmigen Abschnitte (13d, 13b) auf eine derartige Weise ausgebildet sind, daß sich die Mitte des beweglichen Kontakts (13a) auf der Mittellinie des beweglichen Teils (13) befindet; und

einen Querbalken (11), welcher das Ende des zweiten plattenförmigen Abschnitts (13b) hält und an einen Schaltmechanismus (8) gekoppelt ist und welcher in der Lage ist, das bewegliche Teil (13) derart zu betätigen, daß der bewegliche Kontakt (13a) in und aus einen Eingriff mit dem feststehenden Kontakt (2a) bewegt wird.

2. Schutzschalter nach Anspruch 1, *dadurch gekennzeichnet, daß* das bewegliche Teil (13) einen Abschnitt aufweist, welcher sich am nächsten zu dem ersten plattenförmigen Abschnitt (13d) befindet, auf welchem der bewegliche Kontakt (13a) ausgebildet ist und welcher bezüglich dem ersten plattenförmigen Abschnitt (13d) nach innen gebogen ist, womit eine Stufe (13f) vorgesehen ist.

3. Schutzschalter, der aufweist:

ein feststehendes Teil (2), das einen feststehenden Kontakt (2a) auf einem Endabschnitt von ihm aufweist, wobei das feststehende Teil (2) auf der Seite des Bodens (1b) eines Gehäuses (1) aus synthetischem Harz vorgesehen ist;

ein bewegliches Teil (13), das ein L-förmiges Plattenmaterial beinhaltet, das einen Vor-

sprung an einem Ende aufweist, welches um 90° gebogen ist, wobei ein beweglicher Kontakt (13a) auf dem Vorsprung durch Verstemmen vorgesehen ist, wobei das Plattenmaterial auf eine derartige Weise gebogen ist, daß der bewegliche Kontakt (13a) dem feststehenden Kontakt (2a) gegenüberliegt und sich die Mitte des beweglichen Kontakts (13a) auf der Mittellinie des beweglichen Teils (13) befindet; und

einen Querbalken (11), welcher das Ende des zweiten plattenförmigen Abschnitts (13b) hält und an einen Schaltmechanismus (8) gekoppelt ist und welcher in der Lage ist, das bewegliche Teil (13) derart zu betätigen, daß der bewegliche Kontakt (13a) in und aus einen Eingriff mit dem feststehenden Kontakt (2a) bewegt wird.

4. Schutzschalter nach einem der vorhergehenden Ansprüche, *dadurch gekennzeichnet, daß* das Gehäuse (1) aus synthetischem Harz eine Trennwand (1e) aufweist, die einen Schlitz (1d) aufweist, welcher mit dem Abschnitt des beweglichen Teils (13) in Eingriff steht, welcher senkrecht zu dem Boden des Gehäuses (1) hergestellt ist und sich zwischen dem beweglichen Kontakt (13a) des beweglichen Teils (13) und dem Querbalken (11) befindet, wobei die Breite des Schlitzes (1d) derart ausgewählt ist, daß das bewegliche Teil (13) in der Lage ist, sich darin zu bewegen.

5. Bewegliches Teil (13), das in der Lage ist, in einen Schutzschalter eingebaut zu werden, um einen Stromkreis in Zusammenarbeit mit einem einen feststehenden Kontakt (2a) aufweisenden feststehenden Teil (2) zu öffnen und zu schließen, wobei das bewegliche Teil (13) aufweist:

einen ersten plattenförmigen Abschnitt (13d), auf welchem ein beweglicher Kontakt (13a) vorgesehen ist; und

einen zweiten plattenförmigen Abschnitt (13b), der mit 90° bezüglich dem ersten plattenförmigen Abschnitt (13d) ausgerichtet ist, wobei der zweite plattenförmige Abschnitt (13b) eine Mittellinie definiert;

wobei die ersten und zweiten plattenförmigen Abschnitte (13d, 13b) auf eine derartige Weise einstückig miteinander verbunden sind, daß sich eine Mitte des beweglichen Kontakts (13a) im wesentlichen auf der Mittellinie befindet; und

wobei der bewegliche Kontakt (13a) durch Verstemmen an dem Ende des ersten plattenförmigen Abschnitts (13d) befestigt ist.

6. Bewegliches Teil nach Anspruch 5, *dadurch gekennzeichnet, daß* das bewegliche Teil (13) durch Verdrehen des Mittenabschnitts (13e) einer Metallplatte ausgebildet ist, wobei sich dieser Abschnitt zwischen den ersten und zweiten plattenförmigen Abschnitten (13d, 13b) befindet.
7. Bewegliches Teil nach Anspruch 5, *dadurch gekennzeichnet, daß* das bewegliche Teil (13) durch Hämmern eines Metallmaterials ausgebildet ist.
8. Bewegliches Teil nach Anspruch 5, *dadurch gekennzeichnet, daß* der zweite plattenförmige Abschnitt (13d) einen ersten Bereich, der die Mittellinie definiert, einen zweiten Bereich, der parallel zu dem ersten Bereich ist und von der Mittellinie verschoben ist, und einen dritten Bereich beinhaltet, der den ersten Bereich einstückig mit dem zweiten Bereich verbindet, wobei der erste plattenförmige Abschnitt (13b) einstückig mit dem zweiten Bereich verbunden ist.
9. Bewegliches Teil nach Anspruch 8, *dadurch gekennzeichnet, daß* das bewegliche Teil (13) aus einer L-förmigen Metallplatte ausgebildet ist.

Revendications

1. Disjoncteur de circuit, comprenant :

un élément fixe (2) ayant un contact fixe (2a) à une portion d'extrémité de celui-ci, ledit élément fixe (2) étant prévu sur le côté du fond (1b) d'un boîtier (1) en résine synthétique;

un élément mobile (13) comprenant une première et une seconde portions en forme de plaque (13d, 13b) qui sont formées soit en tordant la portion milieu (13e) d'une plaque métallique soit en forgeant un matériau métallique de sorte que lesdites portions en forme de plaque (13d, 13b) sont agencées en un angle de 90° l'une à l'autre, ladite première portion en forme de plaque (13d) ayant un contact mobile (13a) qui est fixé à son extrémité par matage d'une manière telle que ledit contact mobile (13a) soit opposé audit contact fixe (2a), les première et seconde portions en forme de plaque (13d, 13b) sont formées d'une manière telle que le centre dudit contact mobile (13a) soit sur la ligne centrale dudit élément mobile (13); et

une barre transversale (11) qui supporte l'extrémité de ladite seconde portion en forme de plaque (13b) et est couplée à un mécanisme de commutation (8), et qui est adaptée pour actionner ledit élément mobile (13) de sorte que

ledit contact mobile (13a) soit déplacé en engagement et hors d'engagement avec ledit contact fixe (2a).

2. Disjoncteur de circuit selon la revendication 1, *caractérisé en ce que* l'élément mobile précité (13) a une portion qui est proche de la première portion en forme de plaque précitée (13d) sur laquelle est formé le contact mobile précité (13a), et est courbé à l'intérieur par rapport à ladite première portion en forme de plaque (13d), réalisant ainsi un palier (13f).

3. Disjoncteur de circuit, comprenant :

un élément fixe (2) ayant un contact fixe (2a) sur une portion d'extrémité de celui-ci, ledit élément fixe (2) étant prévu sur le côté du fond (1b) d'un boîtier (1) en résine synthétique;

un élément mobile (13) comprenant un matériau en plaque en forme de L ayant une saillie à une extrémité qui est recourbée de 90°, un contact mobile (13a) étant prévu sur ladite saillie par matage, le matériau en plaque étant recourbé d'une manière telle que ledit contact mobile (13a) soit opposé audit contact fixe (2a) et le centre dudit contact mobile (13a) soit sur la ligne centrale dudit élément mobile (13); et

une barre transversale (11) qui supporte l'extrémité de ladite seconde portion en forme de plaque (13b) et est couplée à un mécanisme de commutation (8), qui est adapté pour actionner ledit élément mobile (13) de sorte que ledit contact mobile (13a) soit déplacé en engagement et hors d'engagement avec le et du contact fixe (2a).

4. Disjoncteur de circuit selon l'une des revendications précédentes, *caractérisé en ce que* le boîtier (1) précité en résine synthétique a une paroi de séparation (1e) ayant une fente (1d) qui est engagée avec la portion de l'élément mobile précité (13) qui est rendue perpendiculaire au fond dudit boîtier (1) et est située entre le contact mobile précité (13a) dudit élément mobile (13) et la barre transversale précitée (11), la largeur de ladite fente (1d) étant choisie de façon que ledit élément mobile (13) puisse se déplacer dans celle-ci.

5. Élément mobile (13) adapté pour être installé dans un disjoncteur de circuit pour ouvrir et fermer un circuit en coopération avec un élément fixe (2) ayant un contact fixe (2a), ledit élément mobile (13) comprenant :

une première portion en forme de plaque (13d)

sur laquelle un contact mobile (13a) est prévu;
et

une seconde portion en forme de plaque (13b)
orientée à 90° par rapport à ladite première por- 5
tion en forme de plaque (13d), ladite seconde
portion en forme de plaque (13b) définissant
une ligne centrale;

où lesdites première et seconde portions en for- 10
me de plaque (13d, 13b) sont intégralement re-
liées l'une à l'autre d'une manière telle qu'un
centre dudit contact mobile (13a) soit sensible-
ment situé sur ladite ligne centrale; et

où ledit contact mobile (13a) est fixé à l'extré- 15
mité de ladite première portion en forme de pla-
que (13d) par matage.

6. Élément mobile selon la revendication 5, *caractéri- 20*
sé en ce que ledit élément mobile (13) est formé en
torsadant la portion milieu (13e) d'une plaque mé-
tallique, laquelle portion est située entre les premiè-
re et seconde portions en forme de plaque précitées 25
(13d, 13b).

7. Élément mobile selon la revendication 5, *caractéri- 30*
sé en ce que ledit élément mobile (13) est formé en
forgeant un matériau métallique.

8. Élément mobile selon la revendication 5, *caractéri- 35*
sé en ce que la seconde portion en forme de plaque
précitée (13d) comprend une première section dé-
finissant la ligne centrale précitée, une seconde
section parallèle à ladite première section et dépla- 40
cée de ladite ligne centrale et une troisième section
reliant intégralement ladite première section à ladite
seconde section, où la première portion en forme
de plaque précitée (13b) est reliée intégralement à
ladite seconde section.

9. Élément mobile selon la revendication 8, *caractéri- 45*
sé en ce que ledit élément mobile (13) est formé à
partir d'une plaque métallique en forme de L.

50

55

FIG. 1

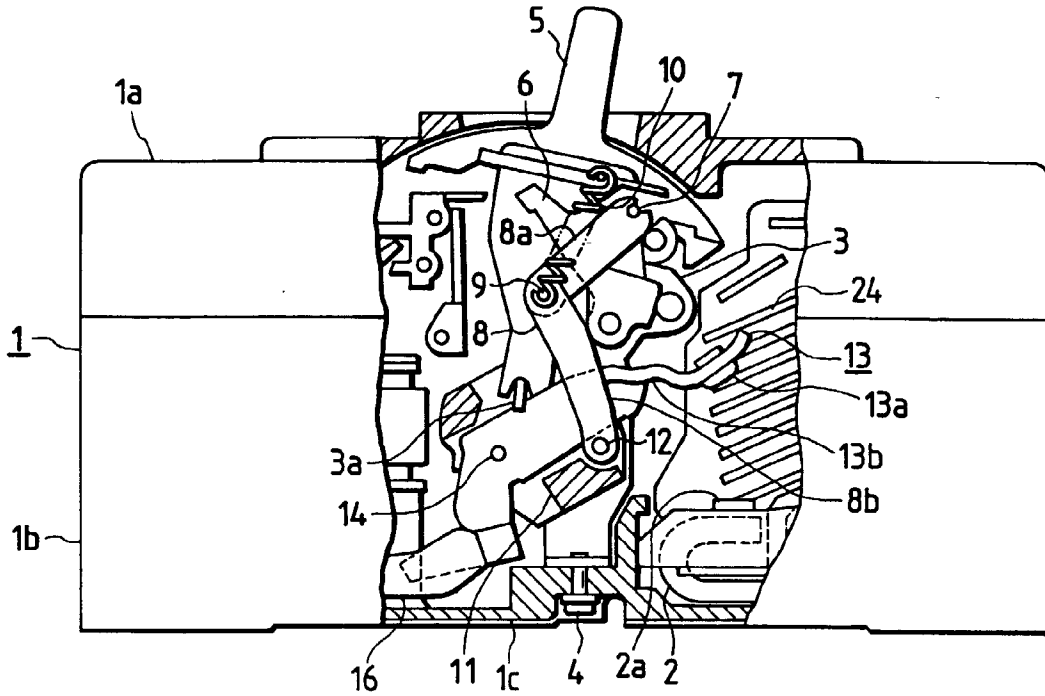

FIG. 2

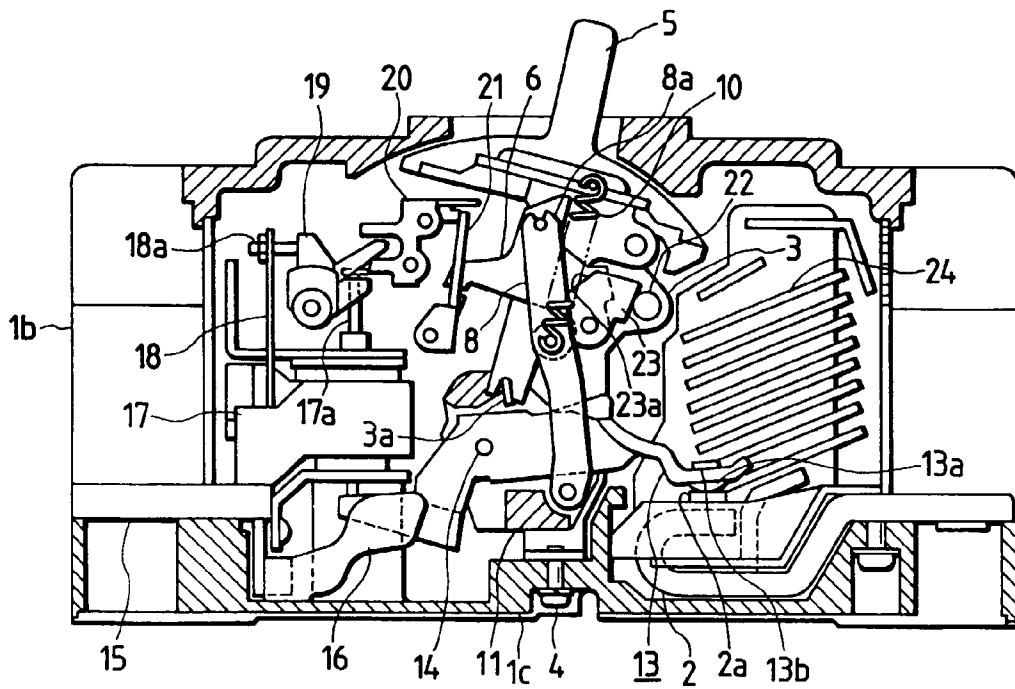

FIG. 3

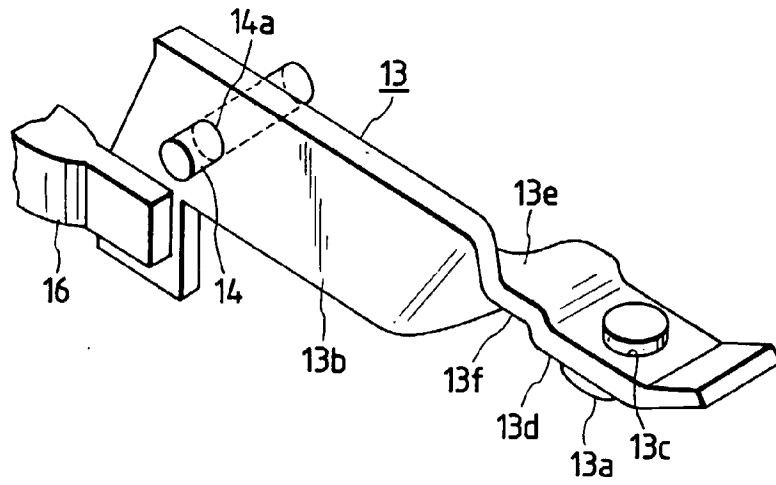

FIG. 4

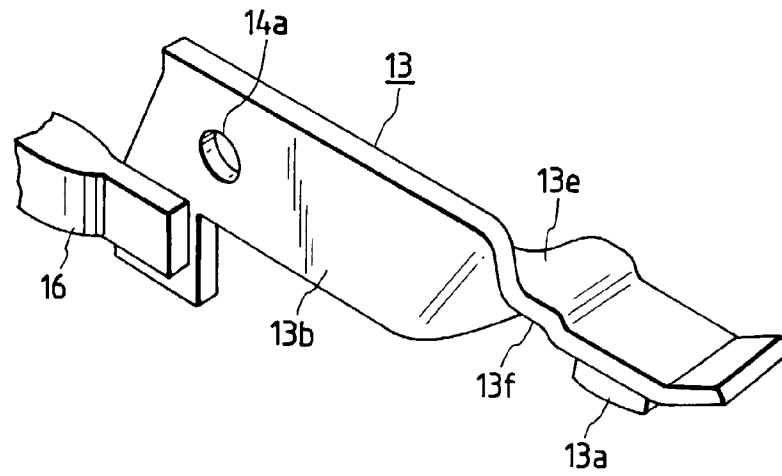

FIG. 5

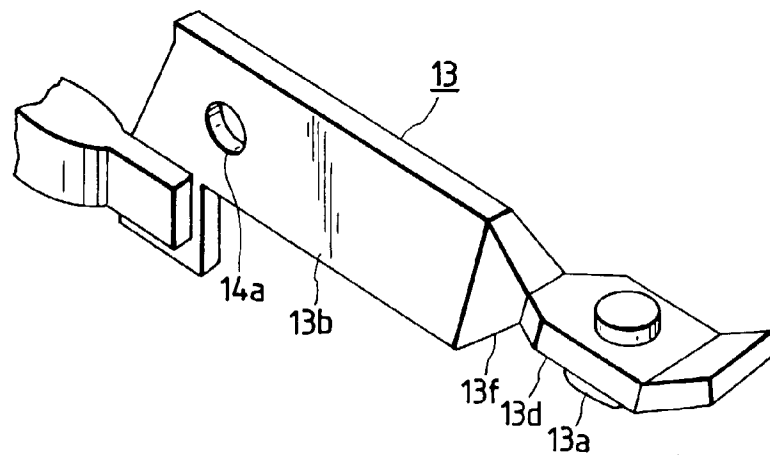

FIG. 6(A)

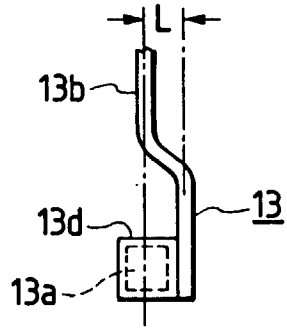

FIG. 6(B)

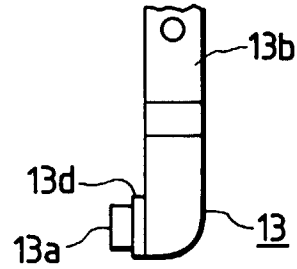

FIG. 7

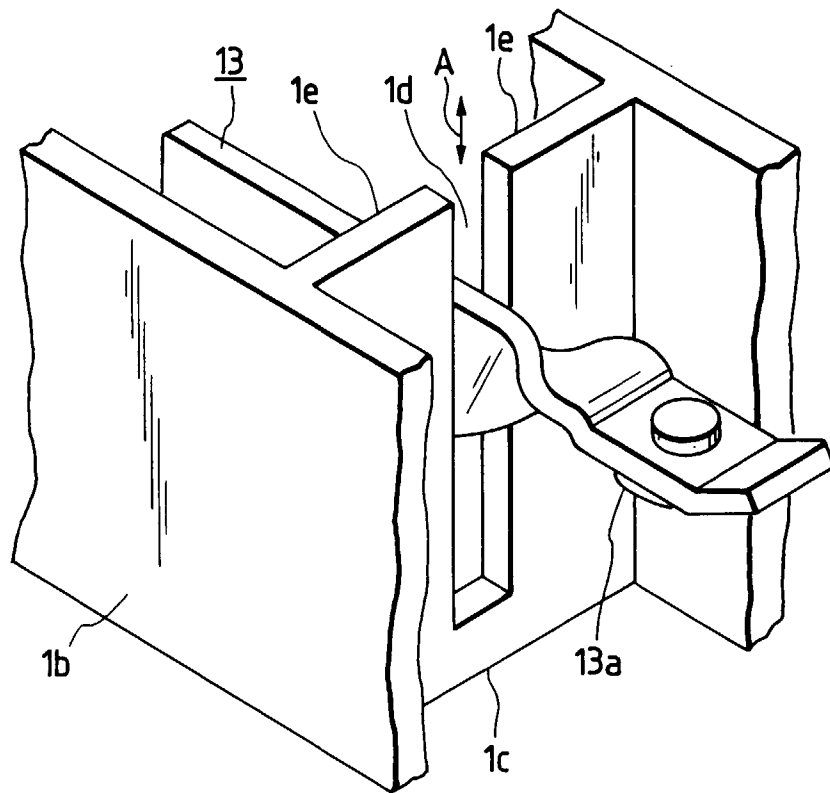

FIG. 8

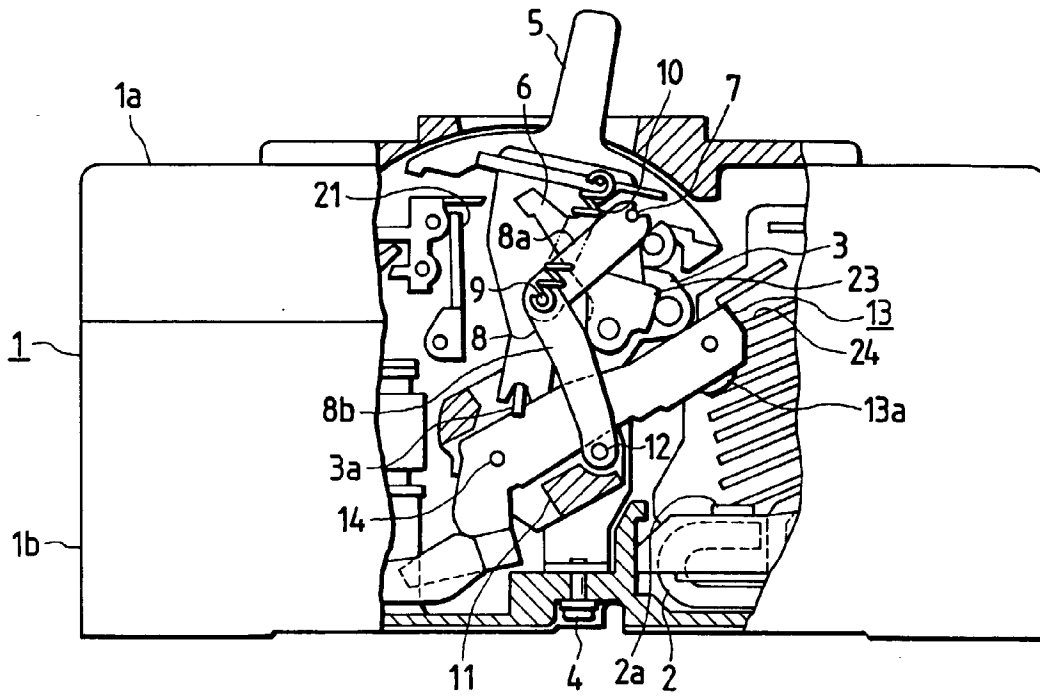

FIG. 9

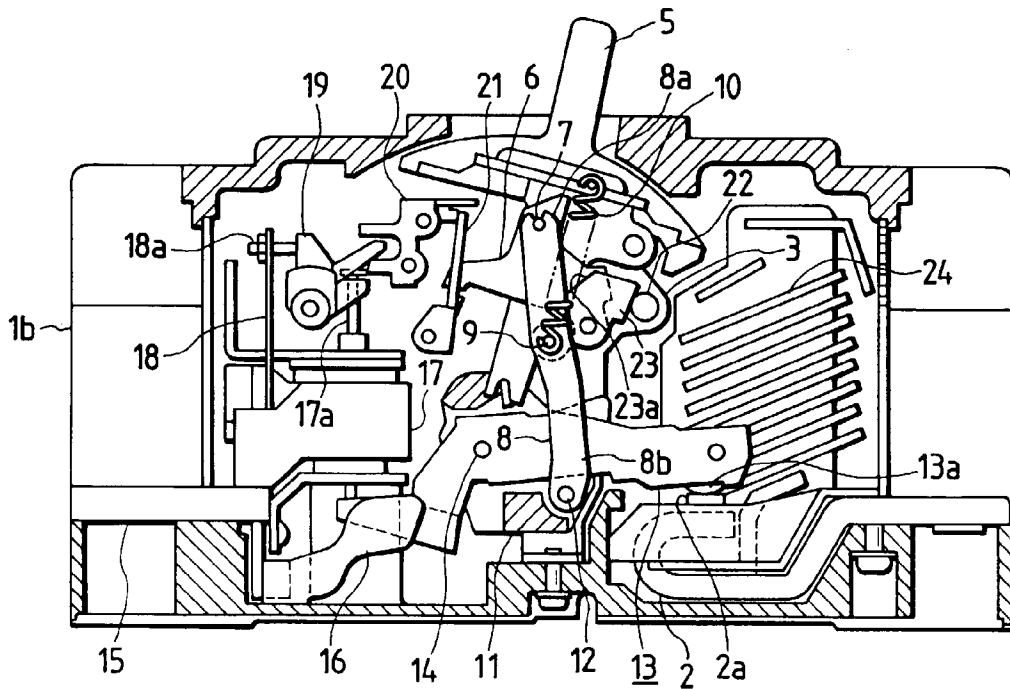

FIG. 10

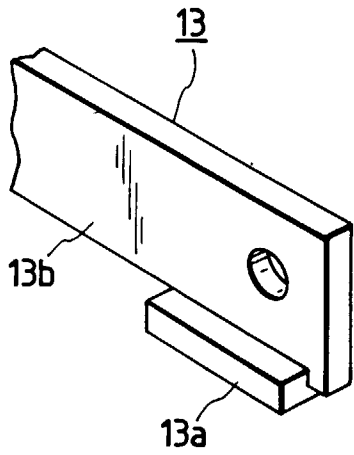

FIG. 11

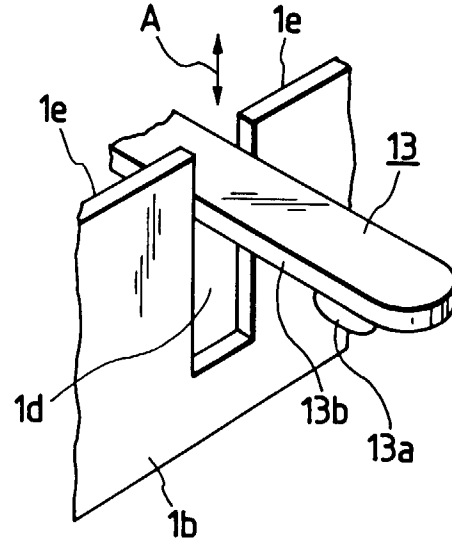

FIG. 12

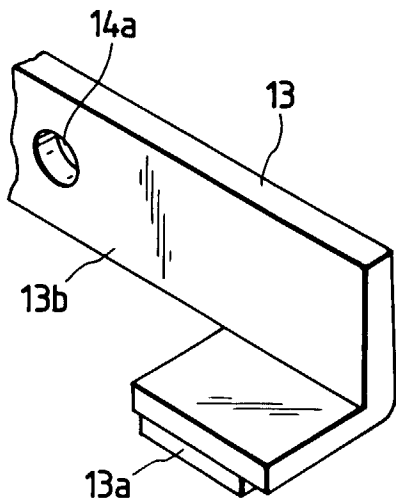

FIG. 13

