

(19) World Intellectual Property Organization  
International Bureau



(10) International Publication Number  
**WO 2011/139780 A1**

(43) International Publication Date  
10 November 2011 (10.11.2011)

- (51) **International Patent Classification:**  
G02B 13/06 (2006.01) H04N 5/225 (2006.01)
- (21) **International Application Number:**  
PCT/US2011/034156
- (22) **International Filing Date:**  
27 April 2011 (27.04.2011)
- (25) **Filing Language:** English
- (26) **Publication Language:** English
- (30) **Priority Data:**  
61/328,213 27 April 2010 (27.04.2010) US  
13/095,407 27 April 2011 (27.04.2011) US
- (71) **Applicant (for all designated States except US):** DUKE UNIVERSITY [US/US]; 2812 Erwin Road, Suite 306, Durham, NC 27705 (US).
- (72) **Inventors; and**
- (75) **Inventors/Applicants (for US only):** MARKS, Daniel [US/US]; 4911 Centerway Drive, Durham, NC 27705 (US). BRADY, David, Jones [US/US]; 2801 Dogwood Rd, Durham, NC 27705 (US).
- (74) **Agent:** WALKER, James, A.; Demont & Breyer, LLC, 100 Commons Way, Ste. 250, Holmdel, NJ 07733 (US).
- (81) **Designated States (unless otherwise indicated, for every kind of national protection available):** AE, AG, AL, AM,

AO, AT, AU, AZ, BA, BB, BG, BH, BR, BW, BY, BZ, CA, CH, CL, CN, CO, CR, CU, CZ, DE, DK, DM, DO, DZ, EC, EE, EG, ES, FI, GB, GD, GE, GH, GM, GT, HN, HR, HU, ID, IL, IN, IS, JP, KE, KG, KM, KN, KP, KR, KZ, LA, LC, LK, LR, LS, LT, LU, LY, MA, MD, ME, MG, MK, MN, MW, MX, MY, MZ, NA, NG, NI, NO, NZ, OM, PE, PG, PH, PL, PT, RO, RS, RU, SC, SD, SE, SG, SK, SL, SM, ST, SV, SY, TH, TJ, TM, TN, TR, TT, TZ, UA, UG, US, UZ, VC, VN, ZA, ZM, ZW.

(84) **Designated States (unless otherwise indicated, for every kind of regional protection available):** ARIPO (BW, GH, GM, KE, LR, LS, MW, MZ, NA, SD, SL, SZ, TZ, UG, ZM, ZW), Eurasian (AM, AZ, BY, KG, KZ, MD, RU, TJ, TM), European (AL, AT, BE, BG, CH, CY, CZ, DE, DK, EE, ES, FI, FR, GB, GR, HR, HU, IE, IS, IT, LT, LU, LV, MC, MK, MT, NL, NO, PL, PT, RO, RS, SE, SI, SK, SM, TR), OAPI (BF, BJ, CF, CG, CI, CM, GA, GN, GQ, GW, ML, MR, NE, SN, TD, TG).

**Published:**  
— with international search report (Art. 21(3))  
— before the expiration of the time limit for amending the claims and to be republished in the event of receipt of amendments (Rule 48.2(h))

(54) **Title:** MONOCENTRIC LENS-BASED MULTI-SCALE OPTICAL SYSTEMS AND METHODS OF USE

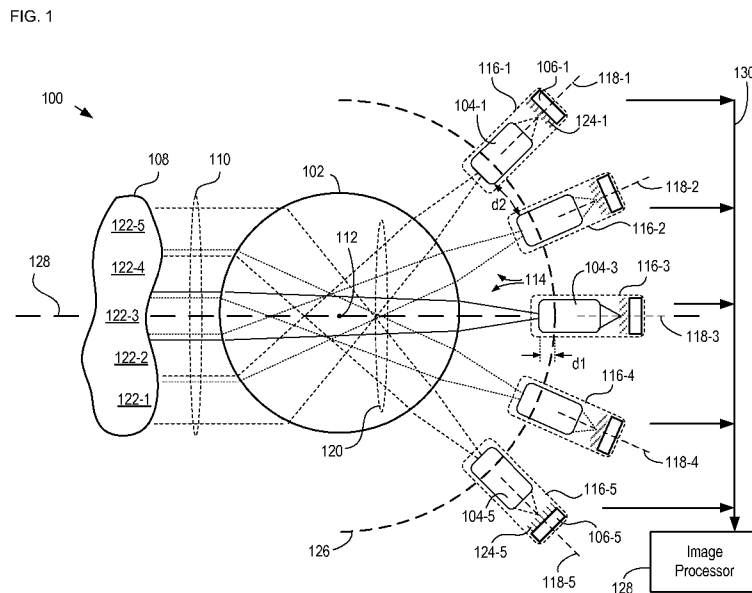

(57) **Abstract:** A monocentric lens-based multi-scale imaging system is disclosed. Embodiments of the present invention comprise a monocentric lens as an objective lens that collects light from a scene. Monocentric lenses in accordance with the present invention include a spherical central lens element and a plurality of lens shell sections that collectively reduce at least one of spherical and chromatic aberration from the magnitude introduced by the spherical lens element itself. A plurality of secondary lenses image the scene through the objective lens and further reduce the magnitude of aberrations introduced by the objective lens. A plurality of sensor arrays converts optical sub-images of the scene into a plurality of digital images, which can then be used to form a composite image of the scene.

WO 2011/139780 A1

## **Monocentric Lens-based Multi-scale Optical Systems and Methods of Use**

### **Cross Reference to Related Applications**

[0001] This case is a continuation-in-part of co-pending U.S. Patent Application Serial Number 12/651,894 (Attorney Docket: 524-005US) filed 04 January 2010, which is incorporated herein by reference in its entirety.

[0002] This application also claims the benefit of U.S. Provisional Patent Application Serial Number 61/328,213, filed April 27, 2010, entitled "Monocentric Lenses for Multi-scale Optical Systems and Methods of Use," (Attorney Docket: DU3409PROV), which is incorporated herein by reference in its entirety.

### **Field of the Invention**

[0003] The present invention relates to optics in general, and, more particularly, to imaging systems.

### **Background of the Invention**

[0004] A digital camera system is normally based on a lens system comprising a number of optical elements that image a scene onto an array of optoelectronic detector elements. As digital camera systems have evolved, these optical elements and detector arrays have been becoming progressively smaller. Unfortunately, angular resolution and number of resolvable object points typically scale with the size of an imaging system. As a result, the optical performance of such camera systems begins to suffer as the optical elements and detector elements continue to shrink.

[0005] Typically, it is desirable for the lens system to (1) collect as much of the light signal as possible over as large an aperture as possible; and (2) process the collected light signal to either form an optical image on the detector array or to encode the light signal for digital image estimation. Each detector in the detector array receives light from the lens system and converts it into an electrical signal whose magnitude is a function of light intensity. These electrical signals are then processed to develop a composite digital image of the scene and/or estimate one or more properties of the scene.

[0006] Lens system design begins by specifying targets for major performance metrics, such as angular resolution, field-of-view, depth of field, spectral range, sensitivity, dynamic range, system mass and volume. Angular resolution is generally the

most significant initial metric. The best angular resolution of a lens is given by  $\lambda/A$ , where  $\lambda$  is the operating wavelength and  $A$  is the collection aperture diameter. Once the collection aperture size has been determined by this relationship, a lens is designed to achieve the remaining performance metrics by judicious choice of materials and surface profiles.

**[0007]** In conventional lens design, the aperture size of an entrance lens or optical stop (*i.e.*, the primary aperture) often determines the effective aperture size of all subsequent lens surfaces (*i.e.*, the secondary aperture) in the lens system. The use of multiple lenses and apertures enables a lens system to simultaneously create an effective focal length and magnification appropriate to the imaging task at hand, reduce image aberrations, and provide correct image orientation. Secondary apertures are typically matched to the effective cross section of the magnified or demagnified entrance aperture propagated through the lens system. In systems with low aberration, the size of the entrance aperture often determines angular resolution of the lens system while the size of the secondary apertures determines the field-of-view of the lens system.

**[0008]** Simple cameras typically balance field-of-view and resolution by using a sequence of lenses having approximately equally sized apertures. Microscopes, on the other hand, achieve large field-of-view and high angular resolution by increasing secondary aperture relative to the collection aperture. Telescopes achieve extra-ordinary angular resolution with a limited field-of-view by decreasing secondary aperture size. Wide-field cameras achieve large field-of-view by tolerating significant aberration across the image with approximately equal primary and secondary apertures. Conventional lens design, therefore, normally requires trade-offs between desired performance metrics. For example, telescopes achieve high angular resolution by sacrificing field-of-view, wide-field imagers achieve large angular fields-of-view by sacrificing diffraction-limited angular resolution, and compound-optics cameras achieve high quality by expanding system volume to include more aberration-correction optics.

**[0009]** In order to overcome some of the limitations of standard imaging optics, multi-aperture cameras have been developed. In multi-aperture systems, a standard camera objective lens is replaced by an array of lenslets, wherein each lenslet has a reduced focal length in comparison to a conventional camera. In such approaches, a detector measures a set of sub-sampled versions of the object within the field-of-view. Post-processing algorithms are used to generate a high-resolution image from the set of sub-sampled sub-images. The result is reduced system volume; however, the reduction in system volume is achieved at the cost of significant computational post-processing and compromised image quality.

[0010] In addition, the design space for multi-aperture cameras is severely restricted, which has limited their adoption in practical systems. The use of a multi-aperture camera requires that the size of its detector array and system aperture be approximately the same size. As a result, conventional multi-aperture designs are generally restricted to very small collection apertures. This also limits the number of camera formats that can be designed. Further, a multi-aperture camera typically has a restricted field-of-view due to a need to prevent the overlapping of sub-images on the detector array. Such overlapping can be avoided by introducing a field stop in the optical design; however, this increases system volume. Alternatively, absorbing barriers can be placed between the sub-image regions of the detector array; however, this significantly increases manufacturing cost and complexity.

[0011] For these reasons, a lens system that avoids some of the design trade-offs associated with conventional lens design and that achieves high performance cost-effectively is desirable.

### **Summary of the Invention**

[0012] The present invention enables optical systems that overcome some of the disadvantages of the prior art. Specifically, the present invention enables multi-scale optical system designs based on an objective lens that is a monocentric compound lens, wherein the objective lens has a spherical geometry and includes a plurality of shell segments. Embodiments of the present invention are particularly well suited for use in high-altitude surveillance systems and wide-field astronomical sky surveying systems.

[0013] In an optical system in accordance with the present invention, an objective lens collects light from a scene and images the light at a substantially spherically shaped image field. A substantially spherically shaped arrangement of secondary lenses is located near, but displaced from, the image field. Each secondary lens processes light received from the objective lens and images it onto a corresponding sensor array, which converts the imaged light into a digital representation of a portion of the scene. The substantially spherically shape of the arrangement of secondary lenses affords embodiments of the present invention the ability to mitigate the effects of field curvature in the output of the objective lens.

[0014] An objective lens in accordance with the present invention is characterized by a layered structure that includes a spherical central lens element and one or more spherically shaped lens shells, wherein all surfaces have a common center of curvature. The lens shells are designed so that refraction at interior surface of the objective lens produces negative spherical aberration that offsets the positive spherical aberration

introduced at the entry surface of the objective lens. The spherically shaped lens shells further enable a reduction in the magnitude of each of chromatic and spherical aberrations in the output of the lens. This reduces the magnitude of chromatic and spherical aberration correction required by the secondary lenses in order to achieve a high-quality image of the scene at the sensor arrays. As a result, the prescription of each secondary lens can be less severe, which, in turn, reduces the amount of coma and astigmatism introduced by the secondary lenses into their respective image fields. In addition, simpler secondary lenses enable a smaller overall optical system volume. Further, a simpler prescription enables secondary lenses that are easier and cheaper to manufacture.

**[0015]** In some embodiments, the spherical central lens comprises a material having a low refractive index and a high Abbe number. In some embodiments, the refractive index of the central lens material is within the range of approximately 1.28 to approximately 1.52. In some embodiments, the Abbe number of the central lens material is within the range of approximately 73 to approximately 96. In some embodiments, the central lens material is calcium fluoride.

**[0016]** An illustrative embodiment of the present invention comprises a monocentric objective lens, a plurality of secondary lenses, and plurality of sensors. The monocentric lens includes a substantially spherical central element and a plurality of spherically shaped shell elements, wherein the central element and shell elements are concentric. The central element comprises calcium fluoride, which provides a positive focusing power for the lens. In addition, calcium fluoride is characterized by low chromatic dispersion, which facilitates correction of chromatic aberration. Each of the shell elements comprises a glass having an Abbe number that is lower than the Abbe number of the central element. The inclusion of the shell elements in the objective lens enables a reduction in the magnitude of both chromatic and spherical aberrations in the output of the lens. In some embodiments, an air gap is included between two of the shell elements, which facilitates simultaneous correction of chromatic and spherical aberration without introducing significant dispersion.

**[0017]** In some embodiments, each secondary lens is paired with a different sensor array to collectively define one of a plurality of substantially identical sub-imaging units. The sub-imaging units collectively provide a composite digital representation of the scene. In some embodiments, the sub-imaging units are arranged such that each image point is received by at least two secondary lenses so that the plurality of secondary lenses collectively provides an image of the scene that is substantially free of blind spots.

[0018] An embodiment of the present invention comprises an optical system for providing an image of a scene, the optical system comprising: (1) a first lens comprising; (a) a first lens element that is substantially a sphere having a center at a first position, wherein the first lens element imparts a first aberration with a first magnitude on light that transits the first lens element; (b) an entry lens shell having a substantially uniform thickness and a center of curvature at the first position; and (c) an exit lens shell having a substantially uniform thickness and a center of curvature at the first position; wherein the first lens element, the entry lens shell, and the exit lens shell collectively impart the first aberration with a second magnitude on light that propagates through the first lens, and wherein the second magnitude is less than the first magnitude; and (2) a plurality of second lenses that collectively image the scene through the first lens, wherein each of the plurality of second lenses has a unique optical axis.

### **Brief Description of the Drawings**

[0019] FIG. 1 depicts a schematic drawing of a multi-scale optical system in accordance with an illustrative embodiment of the present invention.

[0020] FIG. 2 depicts operations of a method suitable for providing an image in accordance with the illustrative embodiment of the present invention.

[0021] FIG. 3 depicts a schematic drawing of a cross-sectional view of an objective lens in accordance with the illustrative embodiment of the present invention.

[0022] FIG. 4 depicts schematic drawing of a cross-sectional view of a camera in accordance with the illustrative embodiment of the present invention.

[0023] FIG. 5A depicts a modulation transfer function curve for a multi-scale optical system in accordance with the illustrative embodiment.

[0024] FIG. 5B-D depict spot size diagrams for system **100** at the surface of a sensor array **106**.

[0025] FIG. 6A depicts a schematic drawing of a side-view of a frame for holding a spherical arrangement of cameras in accordance with the illustrative embodiment of the present invention.

[0026] FIG. 6B depicts a receptor for receiving a camera in accordance with the illustrative embodiment of the present invention.

[0027] FIG. 7 depicts a schematic drawing of a cross-sectional view of an objective lens in accordance with a first alternative embodiment of the present invention.

[0028] FIG. 8 depicts a schematic drawing of a cross-sectional view of a camera in accordance with the first alternative embodiment of the present invention.

[0029] FIG. 9A depicts a modulation transfer function curve for a multi-scale optical system in accordance with first alternative embodiment.

[0030] FIG. 9B-D depict spot size diagrams for an optical system comprising objective lens **700** and camera **800** at a sensor array **810**.

[0031] FIG. 10 depicts a schematic drawing of a cross-sectional view of an imaging system in accordance with a second alternative embodiment of the present invention.

[0032] FIG. 12 depicts a schematic drawing of a cross-sectional view of an objective lens in accordance with a third alternative embodiment of the present invention.

[0033] FIG. 13 depicts modulation transfer function curves for objective lens **1202**.

[0034] FIG. 14 depicts a schematic drawing of a cross-sectional view of an objective lens in accordance with a fourth alternative embodiment of the present invention.

[0035] FIG. 15 depicts modulation transfer function curves for objective lens **1402**.

### **Detailed Description**

[0036] The following terms are defined for use in this Specification, including the appended claims:

- **Spherical** is defined being characterized by (1) a common center of curvature and (2) a uniform radius of curvature. A spherical surface, for example, is a surface that has substantially the same shape as at least a portion of a sphere.
- **Achromatic** is defined as focusing three or more wavelengths at substantially the same focal distance or image field.

[0037] This invention is a continuation-in-part of parent case U.S. Patent Application Serial Number 12/651,894 (Attorney Docket: 524-005US) filed 04 January 2010, entitled "Multi-scale Optical System."

[0038] As disclosed in the parent case, a multi-scale optical system comprises a single objective lens and an array of small secondary lenses. The objective lens and the secondary lenses collectively image a scene onto a plurality of sensor arrays, such as photodetector arrays, as a plurality of optical sub-images. Each secondary lens has a unique optical axis and images a portion of the scene through the objective lens to produce one of the optical sub-images. The sensor arrays convert the plurality of optical sub-images into digital representations (*i.e.*, digital images) of portions of the scene. The plurality of digital images can then be combined to form a composite digital image of the entire scene.

[0039] The multi-scale imaging approach affords significant advantages over other imaging approaches. First, in a multi-scale imaging system, the objective lens and secondary lenses split the task of imaging the scene. Light collection is done at the objective lens, which forms an aberrated image region. The secondary lenses are placed around this image region and each secondary lens relays a portion of the aberrated image to form its optical sub-image at its corresponding planar sensor array. In addition to relaying a portion of the aberrated image, each secondary lens processes the light by at least partially correcting its relayed portion of the aberrated image (*i.e.*,

reduces the magnitude of at least one aberration). This separation enables each of the collecting and processing functions to be individually improved without significantly comprising the design of the other. It also enables a large-scale objective lens to be used with a large-count multi-aperture array, thereby reducing the trade-off between geometric aberration and field-of-view.

**[0040]** In addition, the multi-scale imaging approach enables two adjacent secondary lenses to gather rays from the same image point by locating the secondary lenses at positions displaced from the image field but near one another laterally. Such an arrangement enables light from a given point image to always be captured by at least one secondary lens. As a result, blind spots due to lateral spacing between adjacent sensor arrays are avoided.

**[0041]** Second, the secondary lenses can include a degree of wavefront correction to correct aberrations introduced by the large-scale objective lens. This reduces the design complexity required for the objective lens. This also enables faster collection optics, which reduces overall system volume.

**[0042]** Third, multi-scale imaging is capable of improved image resolution.

**[0043]** Fourth, manufacturing cost and complexity can be significantly lower for a multi-scale imaging system. Smaller lenses are better at providing wavefront correction because: 1) wavefront correction and image formation both yield geometric solutions with less wavelength-scale error over smaller apertures; and 2) manufacturing of complex lens surfaces is much easier in smaller scale systems.

**[0044]** Fifth, in some multi-scale imaging systems, the secondary lenses are designed to focus at diverse ranges with overlapping fields. This enables tomographic object reconstruction by combining multi-scale imaging with multi-dimensional image capture, such as, for example, in a TOMBO-based system (Thin Observation Module by Bound Optics).

**[0045]** Finally, multi-scale design enables the use of multiple discrete focal plane arrays. As a result, the discrete focal plane arrays can be arranged in any advantageous manner, including non-planar arrangements – for example, an arrangement that matches the shape of the image field of the objective lens. Further, the size of the focal plane arrays can be selected at a granularity that reduces fabrication cost and increases overall reliability. Still further, the sub-images from the plurality of focal plane arrays can be collectively synthesized into a spatially correlated image of a scene without the stitching and field uniformity issues found in prior-art imaging systems. And still further, the complexity of the post-processing required to synthesize the full-scene image is

significantly lower for embodiments of the present invention than the computational post-processing required in prior-art imaging systems, such as a TOMBO-based system.

[0046] The present invention enables an improved multi-scale optical system by employing a monocentric lens as the objective lens. Monocentric lenses in accordance with the present invention include a central spherical lens element that interposes an entry lens shell and an exit lens shell.

[0047] FIG. 1 depicts a schematic drawing of a multi-scale optical system in accordance with an illustrative embodiment of the present invention. System **100** comprises objective lens **102**, secondary lenses **104-1** through **104-5**, and sensor arrays **106-1** through **106-5**.

[0048] FIG. 2 depicts operations of a method suitable for providing an image in accordance with the illustrative embodiment of the present invention. Method **200** begins with operation **201**, wherein objective lens **102** is provided.

[0049] Objective lens **102** is a monocentric lens suitable for collecting a sufficient amount of light **110** received from scene **108**. All optical surfaces of objective lens **102** have a center of curvature located at center point **112**.

[0050] A monocentric lens is a lens wherein all surfaces of the lens share a common center of curvature. Monocentric lenses identically focus light coming from any direction. This enables a monocentric lens to be used for very wide-field viewing. The image formed is spherically shaped rather than plane-shaped, and has unit angular magnification. Because of the symmetry of a monocentric lens, aberrations introduced by the lens are independent of the field point. As a result, a monocentric lens introduces significant amounts of only spherical aberration into light that passes through the lens (neglecting image curvature and image distortion). The introduced aberrations are substantially limited to spherical aberration because it is the only aberration that is independent of field point.

[0051] An example of a monocentric lens found in the prior art is the "Luneberg lens," which is described in Luneburg, R.K. (1944) *Mathematical Theory of Optics*, Providence, RI: Brown University: pp. 189-213; Morgan, S.P. (1958) *Journal of Applied Physics* 29: pp. 1358-1368; and Doric, S. Munro, E. (1983) *Journal of the Optical Society of America* 73: pp. 1083-1086; and Southwell, W.H. (1977) *Journal of the Optical Society of America* 67: pp. 1010-1014. The Luneburg Lens comprises a spherically shaped, gradient-index lens that forms images of objects on its surface. The Luneburg lens has been fabricated for operation at microwave frequencies. The Luneburg lens is unsuitable for optical wavelengths, however, for several reasons. First, the

Luneburg lens uses graded refractive indices from 1 to  $\sqrt{2}$ . Excluding exotic meta-materials, glasses are not available within this range of refractive indices. Second, practical gradient-index lenses are difficult to fabricate. Third, gradient-index lenses suffer from severe chromatic aberration and therefore are unsuitable for imaging with broadband light.

[0052] In contrast to the Luneburg lens, objective lenses in accordance with the present invention comprise a layered structure that:

- i. achieve nearly diffraction-limited performance; or
- ii. have a large field-of-view; or
- iii. are apochromatic within the wavelength range from approximately 450 nanometers (nm) to approximately 700 nm; or
- iv. mitigate chromatic and/or spherical aberration; or
- v. are capable of resolving greater than  $10^9$  spots; or
- vi. are practical to fabricate; or
- vii. any combination of i, ii, iii, iv, v, and vi.

[0053] FIG. 3 depicts a schematic drawing of a cross-sectional view of an objective lens in accordance with the illustrative embodiment of the present invention. Objective lens **102** is a multi-element monocentric lens comprising lens element **302**, entry lens shell **304**, and exit lens shell **306**. FIG. 3 is described herein with continuing reference to FIGS. 1 and 2.

[0054] Lens element **302** comprises hemispheres **308** and **310**. Each of hemispheres **308** and **310** comprise calcium fluoride. As a result, lens element **302** is characterized by a refractive index of approximately 1.433848 and an Abbe number of approximately 95.232905. Calcium fluoride is characterized by low chromatic dispersion; therefore, use of calcium fluoride in lens element **302** facilitates chromatic aberration correction in multi-scale optical system **100**. Although calcium fluoride is a preferred material for lens element **302**, in some embodiments, lens element **302** comprises a different material having a refractive index within the range of approximately 1.28 to approximately 1.52. Materials suitable for use in lens element **302** include, without limitation, calcium fluoride, fused silica, BK-7 glass, SK-7 glass, fluorocrown glass, magnesium fluoride, plastics, water, and perfluorooctane. In some embodiments, the material of lens element **302** is selected such that its refractive index is lower than the refractive index of the materials of each of entry lens shell **304** and exit lens shell **306** and, further, such that its Abbe number is higher than the Abbe number of the materials of each of entry lens shell **304** and exit lens shell **306**.

[0055] Hemispheres **308** and **310** are joined at a central plane comprising center point **112** to collectively define a shape that is substantially a sphere having a diameter of approximately 164.5 millimeters (mm). It should be noted that, in some embodiments, lens element **302** comprises optional flat region **312** to facilitate its mounting. In some embodiments, hemispheres **308** and **310** are sculpted so that they substantially include only those portions of spherical surfaces **322** and **324** that interact with the light that transits the lens element **302**.

[0056] Although in the illustrative embodiment the curved surfaces of hemispheres **308** and **310** have substantially the same radius of curvature, it will be clear to one skilled in the art, after reading this Specification, how to specify, make, and use alternative embodiments of the present invention wherein the radius of curvature of the curved surface of hemisphere **308** is different than the radius of curvature of the curved surface of hemisphere **310**.

[0057] Hemisphere **308** comprises pedestal **314**. Pedestal **314** is typically formed by grinding back or etching surface **316** of hemisphere **308** outside the region of the pedestal to form relieved surface **318**. Relieved surface **318** is then coated with layer **320** so that pedestal **314** and layer **320** collectively define an optical stop in the interior of lens **102**. Layer **320** is a layer of opaque or absorbing material disposed on relieved surface **318** in conventional fashion. In some embodiments, the process used to form relieved surface **318** leaves the surface sufficiently opaque to obviate layer **320**.

[0058] When hemispheres **308** and **310** are joined to form lens element **302**, surface **316** of hemisphere **308** and surface **322** of hemisphere **310** collectively form a substantially continuous region of lens material. As a result, surfaces **316** and **322** do not constitute optical surfaces for the purpose of this description, since light that passes through them does not see a material change.

[0059] It should be noted that, although the spherical shape of lens element **302** mitigates introduction of many aberrations on light **120** as it transits the lens element, lens element introduces some spherical aberration and chromatic aberration onto light **120**. It is an aspect of the present invention, however, that by employing properly designed lens shells at the entry and exit points of lens element **302**, the magnitude of one or both of spherical and chromatic aberration introduced by lens element **302** is reduced.

[0060] Entry lens shell **304** is a curved shell section having a substantially spherical shape. In other words, entry lens shell **304** is a portion of a spherical shell. Entry lens shell **304** comprises flint glass (*e.g.*, LASF46A) that is characterized by a

refractive index of approximately 1.903660 and an Abbe number of approximately 31.39976. Entry lens shell **304** has a substantially uniform thickness between spherical surfaces **326** and **328** of approximately 48.163 mm.

[0061] Exit lens shell **306** is a curved shell section having a substantially spherical shape. In other words, exit lens shell **306** is a portion of a spherical shell. Exit lens shell **306** comprises flint glass (*e.g.*, BAF50) that is characterized by a refractive index of approximately 1.6827260 and an Abbe number of approximately 44.503507. Exit lens shell **306** has a substantially uniform thickness between spherical surfaces **330** and **332** of approximately 54.344 mm.

[0062] Objective lens **102** is designed to be substantially achromatic for wavelengths within the range of approximately 500 nm to approximately 600 nm. It has an effective aperture size of approximately 100 mm. In some embodiments, the aperture size of objective lens **102** is within the range of approximately 50 mm to approximately 200 mm; however, it will be clear to one skilled in the art, after reading this specification, how to specify, make, and use an objective lens having any practical aperture size.

[0063] Further, one skilled in the art will recognize that the specific design parameters (*e.g.*, materials, radius of curvature, thickness, refractive index, Abbe number, *etc.*) provided for the elements of objective lens **102** provide only one potential combination of design parameters that define a suitable lens design. For example, one skilled in the art will recognize that the material choices made for the elements of lens **102** could include any of, for example and without limitation, calcium fluoride, fused silica, BK-7 glass, SK-7 glass, fluorocrown glass, magnesium fluoride, or plastics. It will be clear, therefore, after reading this Specification, that objective lenses with reduced spherical aberration and/or reduced chromatic aberration and/or apochromaticism can be achieved with different design parameters.

[0064] Still further, one skilled in the art will recognize that, although objective lens **102** comprises only refractive surfaces, a monocentric lens in accordance with the present invention can include reflective surfaces (*e.g.*, a catadioptric lens).

[0065] Table 1 below summarizes the design parameters for objective lens **102**.

Radius (mm)	Thickness (mm)	Glass (Schott catalog)	Semi-Diameter (mm)	Conic K	Comments
135.000	48.163	LASF46A (n=1.903660, V=31.39976)	128.990		Objective entrance surface
86.737	86.837	CAF2 (n=1.433848, V=95.232905)	84.472		Internal CAF2 sphere
Infinity	86.837	CAF2 (n=1.433848, V=95.232905)	45.551		Objective stop position
-86.837	54.344	BAF50 (n=1.682726, V=44.503507)	82.251		
-141.181	158.819	Air	129.673		Objective exit surface

**Table 1:** Design parameters for a representative monocentric objective lens.

[0066] The inclusion and design of entry lens shell **304** and exit lens shell **306** in objective lens **102** enables entry lens shell **304**, lens element **302**, and exit lens shell **306** to collectively reduce the magnitude of each of spherical aberration and chromatic aberration from the magnitude of these aberrations introduced by lens element **302** individually.

[0067] In addition, the spherical symmetry of optical surfaces **326**, **328**, **322**, **324**, **330**, and **332** results in lens **102** introducing only field-independent aberrations into light **114**. The primary source of aberration introduced by a spherically symmetric lens, such as lens **102**, arises from the refraction of light rays as they enter the front surface (*i.e.*, optical surface **326**) from free space. It is an aspect of the present invention that the layers of lens **102** are designed so that the collective refraction introduced at the rest of the optical surfaces (*i.e.*, optical surfaces **328**, **322**, **324**, **330**, and **332**) produce negative spherical aberration that, at least partially, offsets positive spherical aberration introduced at optical surface **326**.

[0068] Further, although entry lens shell **304** and exit lens shell **306** are spherically symmetric, they comprise different materials and/or shell thickness. This enables aberration correction to be achieved with fewer surfaces.

[0069] Lens **102** forms an aberrated image of scene **108** at spherically shaped image field **126**.

[0070] At operation **202**, each of secondary lenses **104** images one of scene portions **122-1** through **122-5** through objective lens **102**. Each of secondary lenses **104** is paired with one of sensor arrays **106-1** through **106-5** (referred to, collectively, as sensor arrays **106**) to collectively define one of cameras **116-1** through **116-5** (referred to, collectively, as cameras **116**). For example, secondary lens **104-2** and sensor array **106-2** collectively define camera **116-2**.

[0071] Each of secondary lenses **104** produces one of optical sub-images **124-1** through **124-5** (referred to, collectively, as optical sub-images **124**) at its corresponding sensor array **106**. For example, secondary lens **104-3** images scene portion **122-3** through objective lens **102** and forms optical sub-image **124-3** at sensor array **106-3**.

[0072] Cameras **116** are arranged in a substantially spherical arrangement having a center of curvature at center point **112**. As a result, secondary lenses **104** and sensor arrays **106** are also arranged in substantially spherical arrangements whose centers of curvature are center point **112**. Each camera **116** has a unique optical axis **118** that passes through the center of its secondary lens **104** and sensor array **106**.

[0073] Secondary lenses **104** are arranged in an arrangement that is substantially spherical and has a center of curvature substantially located at center point **112**. Each of secondary lenses **104** is displaced from image field **126** by distance **d1**. In addition, each of secondary lenses **104** is separated from nearest neighbors by distance **d2**. Distances **d1** and **d2** are selected to enable light rays from each image point in scene **108** to be captured by at least one secondary lens **104**. As a result, the inclusion of blind spots in a composite image collectively formed by sensor arrays **106** is mitigated.

[0074] In some embodiments, secondary lenses **104** are arranged in a spherical arrangement wherein each of secondary lenses **104** is not displaced from image field **126**. In some embodiments, each of secondary lenses **104** is located further to center point **112** than image field **126**.

[0075] FIG. 4 depicts schematic drawing of a cross-sectional view of a camera in accordance with the illustrative embodiment of the present invention. Camera **116** comprises secondary lens **104**, which comprises lens elements **402**, **404**, **406**, and **408**. Secondary lens **104** is designed to provide an optical sub-image **124** having a diameter within the range of approximately 3 mm to approximately 4 mm.

[0076] Because objective lens **102** is a monocentric lens, it produces substantially the same aberrations for all imaged points. In addition, due to its monocentric nature, objective lens **102** produces little or no off-axis aberrations, such as coma or astigmatism, which would require individual correction by different secondary lenses located at different distances off optical axis **128** of imaging system **100**.

[0077] As a result, the same prescription can be used for each secondary lens **104** without regard for the angle of incoming light into objective lens **102**. This affords embodiments of the present invention with significant advantages. In particular, the fabrication cost for the secondary lenses is dramatically reduced since the same lens

design can simply be replicated. Further, packaging complexity is reduced since the same packaging methodology can be used to align and secure each of secondary lenses **104**. Still further, identical cameras **116** can be produced in volume at lower cost.

[0078] Secondary lens **104** is an axially symmetric combination of lens elements. As a result, secondary lens **104** introduces off-axis aberrations to light **114**. Since secondary lens **104** is relatively small, however, fewer lens elements are required to correct the induced off-axis aberrations than would be required of an axially symmetric lens the size of the objective lens. In addition, in some embodiments, the design of secondary lens **102** includes aspheric surfaces, which enables the secondary lens to achieve good relay optical performance with fewer lens elements. The use of few lens elements reduces overall system weight, system complexity, and cost.

[0079] In some embodiments, the lens elements included in secondary lens **104** are amenable to mass production, such as plastic molding or glass molding. As discussed above, these advantages are afforded by the use of a multi-scale optical system design, which enables a trade-off between simplicity in the objective lens design vs. complexity of the secondary lens design. Complexity is better included in the secondary lens design since it is easier and cheaper to fabricate small complex optics than large complex optics.

[0080] Table 2 below summarizes the design parameters for secondary lens **104**.

Radius (mm)	Thickness (mm)	Glass (Schott catalog)	Semi-Diameter (mm)	Conic K	Comments
Infinity	2.118	F2 (n=1.620040, V=36.366491)	5.000		Start of secondary lens
-29.950	26.713	Air	5.000	7.569	
10.689	2.917	FK51 (n=1.486561, V=84.467994)	5.000	-1.491	
-6.724	5.009	Air	5.000	-3.189	
-1.661	1.895	F2 (n=1.620040, V=36.366491)	5.000	-1.967	Secondary lens stop position
-3.944	1.093	Air	5.000	-2.893	
3.402	6.572	FK51 (n=1.486561, V=84.467994)	5.000	-2.893	
-12.748	5.000	Air	5.000	-7.770	End of secondary lens
Infinity	---	Image Plane	1.717		Image Plane

**Table 2:** Design parameters for a representative secondary lens.

[0081] Lens element **402** is a plano-convex lens having a diameter of approximately 10 mm. Lens element **402** comprises glass having a relatively high refractive index of approximately 1.6200040 and a relatively low Abbe number of approximately 36.366491.

[0082] Lens element **404** is a convex-convex lens having a diameter of approximately 10 mm. Lens element **404** comprises glass having a refractive index of approximately 1.486561 and an Abbe number of approximately 84.467994.

[0083] Lens element **406** is a concave-convex lens having a diameter of approximately 10 mm. Lens element **406** comprises the same glass used in lens element **402**.

[0084] Lens element **408** is a convex-convex lens having a diameter of approximately 10 mm. Lens element **408** comprises the same glass used in lens element **404**.

[0085] Housing **410** is a tube that comprises a material having a low thermal-expansion coefficient. Materials suitable for use in housing **410** include, without limitation, Invar, super Invar, titanium, Zerodur, fused silica, composite materials, and the like.

[0086] Housing **410** aligns and holds lens elements **402**, **404**, **406**, and **408** via precision rails **412**. Precision rails are micromachined silicon rails that separate the lens elements by air gaps as shown in Table 2. In some embodiments, precision rails are conventionally fabricated rails that comprise a material having a low thermal-expansion coefficient. Collectively, lens elements **402**, **404**, **406**, and **408** enable a secondary lens that images a field-of-view of approximately 1.6 degrees.

[0087] Housing **410** also comprises flange **414**, which includes pins **416** and slots **418**. Pins **416** and slots **418** facilitate alignment of housing **410** with receptor **604**, as described below and with respect to FIGS. 6A and 6B.

[0088] At operation **203**, each of sensor arrays **106** converts a received optical sub-image into a digital image of a scene portion **122**.

[0089] Each of sensor arrays **106** comprises a two-dimensional arrangement of 10 million charge-coupled device (CCD) elements **502** having a size of approximately 1.5 microns. As a result, each camera **116** is capable of providing 10 million individual electrical signals that are based on the intensity of light from 10 million image points in scene **108**. In other words, each camera **116** is a 10-megapixel camera. The total size of sensor array **106** is suitable for completely sampling an optical sub-image having a diameter within the range of approximately 3 mm to approximately 4 mm.

[0090] In some embodiments of the present invention, each of sensor arrays comprises a two-dimensional arrangement of another photosensitive device, such as a

CMOS sensor, photodetector, avalanche photodiode, and the like. It will be clear to one skilled in the art how to specify, make, and use sensor arrays **106**.

[0091] Each of sensor arrays **106** is electrically coupled with image processor **128** via communications bus **120**. Image processor **128** is a conventional image processing system that receives electrical signals from each of elements **502** and forms digital sub-images based on optical sub-images **124**.

[0092] At operation **204**, image processor **128** forms a composite digital image of scene **108** based on the plurality of digital sub-images.

[0093] In some embodiments, each of cameras **116** further comprises an automatic focusing mechanism. In some embodiments, autofocus is performed by a helical focusing arrangement or by translating sensor array **106** along the optical axis **118** of the camera. Autofocus capability enables some embodiments of the present invention to focus different portions of scene **108** at different depths.

[0094] In some embodiments, each of cameras **116** comprises an optical filter, such as a polarization or color filter. As a result, such embodiments comprise a capability for analyzing a portion of scene **108** by examining the polarization and/or spectral signature of that portion.

[0095] In the illustrative embodiment, secondary lenses **104** are relied upon to correct residual spherical aberration introduced by objective lens **102**. In addition, secondary lenses **104** correct curvature-of-field of image field **126** to enable formation of optical sub-images at the flat sensor arrays **106**. Further, in the illustrative embodiment, secondary lenses **104** reduce the scale of the image provided by objective lens **102** in order to accommodate gaps between sensor arrays **106**.

[0096] FIG. 5A depicts a modulation transfer function curve for a multi-scale optical system in accordance with the illustrative embodiment. Plot **500** depicts the modulation transfer function (MTF) curve for system **100** at a sensor array **106**.

[0097] FIG. 5B-D depict spot size diagrams for system **100** at the surface of a sensor array **106**.

[0098] FIG. 6A depicts a schematic drawing of a side-view of a frame for holding a spherical arrangement of cameras in accordance with the illustrative embodiment of the present invention.

[0099] Frame **600** is a substantially spherically shaped support that comprises 5000 receptors **602** and **604** for mounting 5000 cameras **116**. Frame **600** is analogous to a portion of geodesic sphere dual, wherein the surface of frame **600** is partitioned into

hexagonal cells (*i.e.*, receptors **602**) and a relatively smaller number (typically  $\leq 12$ ) of pentagonal cells (*i.e.*, receptors **604**). While it is desirable to partition the sphere into faces as uniform as possible, a sphere with greater than 20 faces cannot be tiled into completely uniform faces. This tiling of the surface of frame **600** into receptors **602** and **604** results in a nearly uniform spacing of cameras **116**, however.

[0100] Frame **600** has a radius of approximately 300 mm and a center of curvature located at center point **112**. In some embodiments, frame **600** comprises a low-thermal-expansion material, such as Invar, super Invar, titanium, Zerodur, fused silica, composite materials, and the like. In some embodiments, frame **600** comprises a material whose coefficient of thermal expansion is substantially matched to the material of housing **410**.

[0101] Frame **600** comprises 4988 hexagonal receptors **602** and 12 pentagonal receptors **604**. When receptors **602** and **604** are fully populated with cameras **116**, therefore, system **100** is capable of imaging 50 billion pixels. In some embodiments, the relative number of receptors **602** and **604** is other than 4988 to 12. In some embodiments, the total number of receptors is other than 5000.

[0102] Although in the illustrative embodiment frame **600** predominantly comprises hexagonally shaped receptors, it will be clear to one skilled in the art, after reading this Specification, how to specify, make, and use alternative embodiments of the present invention wherein frame **600** comprises a different arrangement of receptors having shapes other than hexagons. For example, in some alternative embodiments, frame **600** is an icosadeltahedral solid that comprises receptors having the shape of a substantially equilateral triangle. Some other examples of suitable configurations for frame **600** are disclosed by H. Kenner in "Geodesic Math and How to Use it," published by University of California Press (1976), which is incorporated by reference herein.

[0103] FIG. 6B depicts a receptor for receiving a camera in accordance with the illustrative embodiment of the present invention. Receptor **602** comprises through-hole **604**, channel **606**, and threaded holes **608**. Receptor **604** is analogous to receptor **602**.

[0104] Through-hole **604** is dimensioned and arranged to receive housing **410** of camera **116** such that its optical axis **118** is substantially aligned with center point **112**. Each receptor comprises a through-hole into which housing **410** is inserted. Housing **410** is moved laterally in through-hole **604** until optical sub-image **124** is properly focused. Once housing **410** is in place, its position in through-hole **604** is

fixed via set screws, UV-curable epoxy, thermo-set epoxy, or other conventional method. In some embodiments, each receptor **602** has a cross-sectional area of approximately 48.2 mm<sup>2</sup>.

[0105] Rotational alignment of sensor array **106** established by rotating housing **410** about optical axis **118**. Once sensor array **106** is rotationally aligned, its position is fixed via screws inserted through holes **418** that mate with threaded holes **608**.

[0106] Pins **416** mate with channel **606** to center sensor array **106** on optical axis **118**.

[0107] Frame **600**, receptors **602**, and housings **410** collectively enable an arrangement of the cameras **116** that generates a mosaic of sub-images of scene **108**. By virtue of this mosaic arrangement, embodiments of the present invention are afforded with several advantages over imaging systems of the prior art. First, such an arrangement enables overlapping fields-of-view to be used, which relieves a significant constraint for prior-art imaging systems wherein the focal plane array that receives an image of a scene must comprise photodetectors that are immediately adjacent to one another. As a consequence, each of sensor arrays **106** can be sized to optimize cost, yield, *etc.* Further, such an arrangement also enables the use of detector arrays that are different sizes, if desired. Still further, detector arrays **106** can be spaced to allow for the inclusion of electronics between them. Finally, by forming a mosaic of sub-images, multiple-aperture cameras that jointly optimize physical filtering, sampling, and digital processing of the resultant images can be used.

[0108] It should be noted that the arrangement of cameras depicted in FIG. 1 shows secondary lenses **104** (and sensor arrays **106**) that are quite widely spaced apart from one another. The large spacing is merely for the purposes of clarity. One skilled in the art will recognize, after reading this Specification, that practical arrangements of secondary lenses **104** will typically include more secondary lenses that are spaced more closely. In some embodiments, for example, each secondary lens **104** images a field-of-view within the range of approximately 1 degree to approximately 5 degrees. As a result, hundreds of secondary lenses and sensor arrays would be required to provide an image having a 120-degree included angle. One skilled in the art will recognize, after reading this Specification, that the field-of-view imaged by each secondary lens and the total field-of-view of system **100** are matters of design and can have any practical value.

[0109] FIG. 7 depicts a schematic drawing of a cross-sectional view of an objective lens in accordance with a first alternative embodiment of the present invention. Objective lens **700** comprises lens element **702**, entry lens shell **704**, and exit lens shell **706**.

[0110] Objective lens **700** is analogous to objective lens **102**.

[0111] Lens element **702** comprises hemispheres **708** and **710**. Each of hemispheres **708** and **710** comprise glass having a refractive index of approximately 1.486561 and an Abbe number of approximately 84.467994.

[0112] Hemispheres **708** and **710** are joined at a central plane comprising center point **112** to collectively define a shape that is substantially a sphere having a diameter of approximately 156.42 mm.

[0113] Hemisphere **708** comprises pedestal **714**. Pedestal **714** is analogous to pedestal **314**. Layer **320** is disposed on relieved surface **718**.

[0114] Entry lens shell **704** is a curved shell section that is a portion of a spherical shell. Entry lens shell **704** comprises glass having a refractive index of approximately 2.022040 and an Abbe number of approximately 29.059788. Entry lens shell **704** has a substantially uniform thickness of approximately 56.792 mm.

[0115] Exit lens shell **706** is a curved shell section that is a portion of a spherical shell. Exit lens shell **706** comprises glass having a refractive index of approximately 1.66819 and an Abbe number of approximately 44.961828. Exit lens shell **706** has a substantially uniform thickness of approximately 59.181 mm.

[0116] FIG. 8 depicts a schematic drawing of a cross-sectional view of a camera in accordance with the first alternative embodiment of the present invention. Camera **800** comprises lens elements **802**, **804**, **806**, and **808**, sensor array **810**, and housing **812**.

[0117] Lens element **802** is a plano-convex lens having a diameter of approximately 5 mm. Lens element **802** comprises glass having a refractive index of approximately 1.677900 and an Abbe number of approximately 55.199566.

[0118] Lens element **804** is a convex-plano lens having a diameter of approximately 5 mm. Lens element **804** comprises glass having a refractive index of approximately 1.434250 and a relatively high Abbe number of approximately 94.953489.

[0119] Lens element **806** is a convex-convex lens having a diameter of approximately 5 mm. Lens element **806** comprises the same glass used in lens element **802**.

[0120] Lens element **808** has a compound front surface and a concave back surface and has a diameter of approximately 5 mm. Lens element **808** comprises the same glass used in lens element **804**.

[0121] Objective lens **700** and camera **800** are designed to operate cooperatively to produce optical sub-images having a diameter within the range of approximately 7 mm to approximately 8 mm.

[0122] Sensor array **810** is analogous to sensor array **106**; however, sensor array **810** has a size suitable for completely sampling an optical sub-image having a diameter within the range of approximately 7 mm to approximately 8 mm.

Radius (mm)	Thickness (mm)	Glass (Schott catalog)	Semi-Diam. (mm)	Conic K	Comments
135.000	56.792	LASF35 (n=2.022040, V=29.059788)	128.212		Objective entrance surface
78.208	78.208	FK51A (n=1.486561, V=84.467994)	75.882		Internal FK51A sphere
Infinity	78.208	FK51A (n=1.486561, V=84.467994)	39.813		Objective stop position
-78.208	59.181	BAF13 (n=1.66819, V=44.961828)	74.114		
-137.389	162.611	Air	125.621		Objective exit surface
89.806	3.538	LAKN12 (n=1.677900, V=55.199566)	5.000		Start of microlens
-21.746	26.434	Air	5.000	-1.092	
14.612	3.978	FK56 (n=1.434250, V=94.953489)	5.000	-4.310	
2123.027	6.494	Air	5.000		Microlens stop position
19.622	7.348	LAKN12 (n=1.677900, V=55.199566)	5.000		
-21.569	3.580	Air	5.000		
10.735	4.207	FK56 (n=1.434250, V=94.953489)	5.000	-10.122	
3.006	6.000	Air	5.000	-0.919	End of microlens
Infinity	---	Image Plane	3.622		Image Plane

**Table 3:** Design parameters for objective lens 700 and camera 800.

[0123] FIG. 9A depicts a modulation transfer function curve for a multi-scale optical system in accordance with first alternative embodiment. Plot **900** depicts the MTF curve for an optical system comprising objective lens **700** and camera **800** at a sensor array **810**.

[0124] FIG. 9B-D depict spot size diagrams for an optical system comprising objective lens **700** and camera **800** at a sensor array **810**.

[0125] FIG. 10 depicts a schematic drawing of a cross-sectional view of an imaging system in accordance with a second alternative embodiment of the present invention. System **1000** comprises objective lens **1002** and cameras **1004-1** through **1004-5**.

[0126] Objective lens **1002** is a monocentric lens comprising lens element **1006**, entry lens shell **1008**, and exit lens shell **1010**. Objective lens **1002** has an effective aperture of approximately 100 mm and achieves substantially diffraction-limited performance over a field-of-view of approximately 120 degrees. Objective lens **1002** is substantially achromatic over a wavelength range from approximately 450 nm to approximately 700 nm.

[0127] Lens element **1006** is analogous to lens element **302** described above and with respect to FIG. 3. Like lens element **302**, lens element **1006** comprises calcium fluoride to exploit this material's low chromatic dispersion and provide positive focusing power for objective lens **1002**.

[0128] Lens element **1006** comprises hemispheres **1012** and **1014**. Hemispheres **1012** and **1014** collectively form a shape that is substantially a sphere. Lens element **1006** has a diameter of approximately 120 mm and includes an optical stop located approximately at center point **112** of the lens.

[0129] Entry lens shell **1008** comprises shell layers **1016** and **1018**, which are in physical contact with each other. Shell layer **1018** is in physical contact with lens element **1006**.

[0130] Shell layer **1016** is a curved shell section that is a portion of a spherical shell. Shell layer **1016** comprises glass having a refractive index of approximately 1.591965 and an Abbe number of approximately 48.509579. Shell layer **1016** has a substantially uniform thickness of approximately 17.043 mm.

[0131] Shell layer **1018** is a curved shell section that is a portion of a spherical shell. Shell layer **1018** comprises glass having a refractive index of approximately 1.753930 and an Abbe number of approximately 52.270764. Shell layer **1018** has a substantially uniform thickness of approximately 44.792 mm.

[0132] Exit lens shell **1010** comprises shell layers **1020** and **1024**, which are separated by a air gap **1022**, which has a substantially uniform thickness of approximately 12.291 mm.

[0133] Shell layer **1020** is a curved shell section that is a portion of a spherical shell. Shell layer **1020** comprises glass having a refractive index of approximately 1.772500 and an Abbe number of approximately 49.620227. Shell layer **1020** has a substantially uniform thickness of approximately 16.213 mm.

[0134] Shell layer **1022** is a curved shell section that is a portion of a spherical shell. Shell layer **1022** comprises glass having a refractive index of approximately 1.640480 and an Abbe number of approximately 59.749915. Shell layer **1022** has a substantially uniform thickness of approximately 42.171 mm.

[0135] The inclusion of air gap **1022** between shell layers **1020** and **1024** enables substantially control of spherical aberration correction that is substantially independent from control of chromatic aberration correction. Spherical aberration control can be implemented by controlling the thickness of air gap **1022**, which is inherently achromatic.

[0136] Objective lens **1002** produces an image at spherically shaped image field **1026**.

[0137] Each of cameras **1004-1** through **1004-5** (referred to, collectively, as cameras **1004**) comprises a secondary lens **1028** and a sensor array **1030**. Cameras **1004** are arranged in a substantially spherically shaped arrangement, centered at center point **112**, such that each of secondary lenses **1028** is located at image field **1026**.

[0138] Sensor array **1030** is analogous to sensor array **106** described above and with respect to FIG. 1. Conventional packaging for a sensor array, such as sensor array **1030** includes an optical window located above the array of sensors. In the illustrative embodiment, secondary lens **1028** is formed by polishing the outward surface of the sensor package window to form a concave lens having a radius-of-curvature of approximately 101.810 mm (wherein the window comprises BK7 glass).

[0139] Secondary lens **1028** provides curvature-of-field correction over the included angle of the field-of-view of camera **1004**. Typically the field-of-view of each of cameras **1004** is approximately 4 degrees; however, it will be clear to one skilled in the art, after reading this specification, how to specify, make, and use alternative embodiments of the present invention wherein cameras **1004** have any practical field-of-view.

[0140] Table 4 below summarizes the design parameters for system **1000**.

Radius (mm)	Thickness (mm)	Glass (Schott catalog)	Semi-Diameter (mm)	Comments
120.000	17.043	KZFS6 (n=1.591965,V=48.509579)	114.143	
102.957	44.792	LAK33A (n=1.753930,V=52.270764)	98.582	
58.165	58.165	CAF2 (n=1.433848,V=95.232905)	57.172	Internal CAF2 sphere
Infinity	58.165	CAF2 (n=1.433848,V=95.232905)	37.271	Stop position
-58.165	16.213	LAF34 (n=1.772500,V=49.620227)	56.264	
-74.377	12.291	Air	70.830	
-86.669	42.171	LAKL21 (n=1.640480,V=59.749915)	81.112	
-128.840	150.147	Air		
-101.810	1.000	BK7 (n=1.516800,V=64.167336)	10.0	Field curvature corrector
Infinity	0.500	Air	10.0	window
Infinity	---	Image Plane	10.0	20 mm diagonal sensor

**Table 4:** Design parameters for a optical system 1000.

[0141] Secondary lens **1028** provides curvature-of-field correction over the included angle of the field-of-view of camera **1004**. Typically the field-of-view of each of cameras **1004** is approximately 4 degrees; however, it will be clear to one skilled in the art, after reading this specification, how to specify, make, and use alternative embodiments of the present invention wherein cameras **1004** have any practical field-of-view.

[0142] FIG. 11 depicts modulation transfer function curves for optical system **1000**. Plot **1102** depicts the MTF curve at a single 8-mm sensor array **1030**, wherein secondary lens **1028** has an approximately 8 degree field-of-view. Plot **1104** depicts the MTF curve for optical system **1000** for a field-of-view of up to approximately 60 degrees off-axis from optical axis **128**.

[0143] FIG. 12 depicts a schematic drawing of a cross-sectional view of an objective lens in accordance with a third alternative embodiment of the present invention. Objective lens **1202** is a monocentric lens comprising lens element **1204**, entry lens shell **1206**, and exit lens shell **1208**. Objective lens **1202** is analogous to objective lens **1002**, but has an effective aperture that is less than 100 mm. Objective lens **1202** is suitable for use in an optical system analogous to optical system **1000**.

[0144] Lens element **1204** comprises hemispheres **1210** and **1212**, each of which comprises calcium fluoride. Hemispheres **1210** and **1212** collectively form a shape that is substantially a sphere. Lens element **1204** has a diameter of approximately 33 mm and includes an optical stop located approximately at center point **112** of the lens.

[0145] Entry lens shell **1206** is a curved shell section that is a portion of a spherical shell. Entry lens shell **1206** comprises glass having a refractive index of approximately 1.696732 and an Abbe number of approximately 56.420174. Entry lens shell **1206** is in physical contact with lens element **1204** and has a substantially uniform thickness of approximately 23.457 mm.

[0146] Exit lens shell **1208** comprises shell layers **1216** and **1220**, which are separated by air gap **1218**, which has a substantially uniform thickness of approximately 4.076 mm.

[0147] Shell layer **1216** is a curved shell section that is a portion of a spherical shell. Shell layer **1216** comprises glass having a refractive index of approximately 1.835010 and an Abbe number of approximately 43.129044. Shell layer **1216** has a substantially uniform thickness of approximately 5.053 mm.

[0148] Shell layer **1220** is a curved shell section that is a portion of a spherical shell. Shell layer **1220** comprises glass having a refractive index of approximately 1.640480 and an Abbe number of approximately 59.749915. Shell layer **1220** has a substantially uniform thickness of approximately 42.171 mm.

[0149] Objective lens **1202** produces an image at spherically shaped image field **1222**. In similar fashion to optical system **1000**, objective lens **1202** is suitable for use with a plurality of cameras (analogous to cameras **1002**), located at image field **1222**, used to relay image portions of a scene through objective lens **1202**.

[0150] Table 5 below summarizes the design parameters for objective lens **1202**.

Radius	Thicknes	Glass (Schott catalog)	Semi-	Comments

(mm)	s (mm)		Diameter (mm)	
40.000	23.457	LAK31 (n=1.696732,V=56.420174)	38.021	
16.543	16.543	CAF2 (n=1.433848,V=95.232905)	16.384	Internal CAF2 sphere
Infinity	16.543	CAF2 (n=1.433848,V=95.232905)	12.140	Stop position
-16.543	5.053	LASF41 (n=1.835010,V=43.129044)	16.223	
-21.596	4.076	Air	20.855	
-25.671	7.998	PK1 (n=1.503781,V=66.921827)	24.307	
-33.669	45.508	Air		

**Table 5:** Design parameters for objective lens 1202.

[0151] FIG. 13 depicts modulation transfer function curves for objective lens **1202**. Plot **1202** depicts the MTF curve using a single 10-mm sensor array with a secondary lens for providing curvature-of-field correction, wherein the secondary lens has an approximately 6 degree field-of-view. Plot **1204** depicts the MTF curve for objective lens **1202** (and suitable secondary lenses) for a field-of-view of up to approximately 60 degrees off-axis from optical axis **128**.

[0152] FIG. 14 depicts a schematic drawing of a cross-sectional view of an objective lens in accordance with a fourth alternative embodiment of the present invention. Objective lens **1402** is a monocentric lens comprising lens element **1404**, entry lens shell **1406**, and exit lens shell **1408**. Objective lens **1402** is analogous to objective lens **1002**, but has an effective aperture that is less than 75 mm. Objective lens **1402** is suitable for use in an optical system analogous to optical system **1000**.

[0153] Lens element **1404** comprises hemispheres **1410** and **1412**, each of which comprises calcium fluoride. Hemispheres **1410** and **1412** collectively form a shape that is substantially a sphere. Lens element **1404** has a diameter of approximately 23 mm and includes an optical stop located approximately at center point **112** of the lens.

[0154] Entry lens shell **1406** is a curved shell section that is a portion of a spherical shell. Entry lens shell **1406** comprises glass having a refractive index of approximately 1.696732 and an Abbe number of approximately 56.420174. Entry lens shell **1406** is in physical contact with lens element **1404** and has a substantially uniform thickness of approximately 8.358 mm.

[0155] Exit lens shell **1408** is a curved shell section that is a portion of a spherical shell. Exit lens shell **1408** comprises glass having a refractive index of approximately 1.637750 and an Abbe number of approximately 42.410177. Exit lens shell **1408** is in physical contact with lens element **1404** and has a substantially uniform thickness of approximately 9.53 mm.

[0156] Objective lens **1402** produces an image at spherically shaped image field **1414**. In similar fashion to optical system **1000**, objective lens **1402** is suitable for use with a plurality of cameras (analogous to cameras **1002**), located at image field **1414**, used to relay image portions of a scene through objective lens **1402**.

[0157] Table 6 below summarizes the design parameters for objective lens **1402**.

<b>Radiu s (mm)</b>	<b>Thicknes s (mm)</b>	<b>Glass (Schott catalog)</b>	<b>Semi- Diamete r (mm)</b>	<b>Comment s</b>
20.000	8.358	LAK31 (n=1.696732,V=56.420174 )	19.024	
11.642	11.642	CAF2 (n=1.433848,V=95.232905 )	11.351	Internal CAF2 sphere
Infinity	11.642	CAF2 (n=1.433848,V=95.232905 )	6.343	Stop position
-11.642	9.530	KZFS11 (n=1.637750,V=42.410177 )	11.059	
-21.172	23.419	Air		

**Table 6:** Design parameters for objective lens 1402.

[0158] FIG. 15 depicts modulation transfer function curves for objective lens **1402**. Plot **1402** depicts the MTF curve using a single 10-mm sensor array with a secondary lens for providing curvature-of-field correction, wherein the secondary lens has an approximately 8 degree field-of-view. Plot **1404** depicts the MTF curve for objective lens **1402** (and suitable secondary lenses) for a field-of-view of up to approximately 60 degrees off-axis from optical axis **128**.

[0159] It is to be understood that the disclosure teaches just one example of the illustrative embodiment and that many variations of the invention can easily be devised by those skilled in the art after reading this disclosure and that the scope of the present invention is to be determined by the following claims.

What is claimed is:

**1.** An optical system for providing an image of a scene, the optical system comprising:

(1) a first lens comprising;

(a) a first lens element ~~that is substantially a sphere~~ having a center at a first position, the first lens element comprising;

(i) a first hemisphere having a first surface whose center of curvature is located at the first position; and

(ii) a second hemisphere having a second surface whose center of curvature is located at the first position;

wherein the first lens element imparts a first aberration with a first magnitude on light that transits the first lens element;

(b) an entry lens shell having a substantially uniform thickness and a center of curvature at the first position; and

(c) an exit lens shell having a substantially uniform thickness and a center of curvature at the first position;

wherein the first lens element interposes the entry lens shell and exit lens shell, and wherein the first lens element, the entry lens shell, and the exit lens shell collectively impart the first aberration with a second magnitude on light that propagates through the first lens, and wherein the second magnitude is less than the first magnitude; and

(2) a plurality of second lenses that collectively image the scene through the first lens, wherein each of the plurality of second lenses has a unique optical axis.

**2.** The optical system of claim 1 wherein the aberration is spherical aberration.

**3.** The optical system of claim 1 wherein the aberration is chromatic aberration.

**4.** The optical system of claim 1 wherein the first lens element imparts a second aberration with a third magnitude on light that transits the first lens element, and wherein the first lens element, the entry lens shell, and the exit lens shell collectively impart the second aberration with a fourth magnitude on light that propagates through the first lens, and wherein the fourth magnitude is less than the third magnitude.

**5.** The optical system of claim 4 wherein the first aberration is spherical aberration and the second aberration is chromatic aberration.

**6.** The optical system of claim 1 wherein the exit lens shell comprises a first shell layer and a second shell layer, and wherein each of the first shell layer and the second

shell layer has substantially uniform thickness, and further wherein the first shell layer and second shell layer are separated by an air gap.

**7.** The optical system of claim 6 wherein the air gap is dimensioned and arranged such that the first lens has a first focal length for each of a first wavelength, second wavelength, and third wavelength.

**8.** The optical system of claim 1 wherein the first lens comprises an optical stop.

**9.** The optical system of claim 1 wherein the first lens has a first focal length for each of a first wavelength, second wavelength, and third wavelength.

**10.** The optical system of claim 1 further comprising a plurality of sensor arrays, wherein each of the plurality of second lenses images a portion of the scene onto a different one of the sensor arrays.

**11.** The optical system of claim 1 wherein the plurality of second lenses is arranged in a first arrangement that is substantially spherical.

**12.** The optical system of claim 11 wherein the plurality of sensor arrays is arranged in a second arrangement that is substantially spherical.

---

**13.** An optical system for providing an image of a scene, the optical system comprising:

- (1) a first lens that is monocentric about a first position, the first lens comprising;
  - (a) an entry lens shell;
  - (b) an exit lens shell; and
  - (c) a first lens element that interposes the entry lens shell and the exit lens shell, the first lens element comprising;
    - (i) a first hemisphere having a first surface whose center of curvature is located at the first position; and
    - (ii) a second hemisphere having a second surface whose center of curvature is located at the first position;

wherein the first lens element, the entry lens shell, and the exit lens shell are collectively apochromatic; and

- (2) a plurality of second lenses that collectively image the scene through the first lens, wherein each of the plurality of second lenses has a unique optical axis.

**14.** The optical system of claim 13 wherein the first lens comprises an entry surface and a plurality of internal surfaces comprising the first surface and second surface, and wherein the first lens is dimensioned and arranged such that light that

transits the first lens is subject to a first spherical aberration introduced by the entry surface and a second spherical aberration collectively introduced by the plurality of internal surfaces, and further wherein the first spherical aberration and the second collective spherical aberration are of opposite sign.

**15.** The optical system of claim 13 further comprising a plurality of sensor arrays, wherein each of the plurality of second lenses images a portion of the scene onto a different one of the sensor arrays.

**16.** The optical system of claim 13 wherein the entry lens shell comprises a plurality of shell layers.

**17.** The optical system of claim 13 wherein the exit lens shell comprises a first shell and a second shell layer, and wherein each of the first shell layer and the second shell layer has substantially uniform thickness, and further wherein the first shell layer and second shell layer are separated by an air gap.

**18.** The optical system of claim 17 wherein the first shell layer and second shell layer are separated by an air gap.

**19.** The optical system of claim 13 wherein the first lens further comprises an optical stop.

**20.** The optical system of claim 13 wherein the first lens element comprises a material having a refractive index within the range of approximately 1.28 to approximately 1.52.

**21.** The optical system of claim 13 wherein the first lens element comprises calcium fluoride.

**22.** The optical system of claim 21 wherein at least one of the entry lens shell and the exit lens shell comprises flint glass.

**23.** The optical system of claim 21 wherein at least one of the entry lens shell and the exit lens shell comprises crown glass.

**24.** The optical system of claim 13 further comprising a plurality of sensor arrays, wherein each of the plurality of second lenses images a portion of the scene onto a different one of the sensor arrays.

**25.** The optical system of claim 13 wherein the plurality of second lenses is arranged in a first arrangement that is substantially spherical.

**26.** The optical system of claim 25 wherein the plurality of sensor arrays is arranged in a second arrangement that is substantially spherical.

---

**27.** A method for providing an image of a scene, the method comprising:  
providing a first lens that is monocentric about a first position, wherein the first lens comprises a first lens element that is spherical, an entry lens shell, and an exit lens shell, and wherein the first lens element comprises;

(a) a first hemisphere having a first surface whose center of curvature is located at the first position; and

(b) a second hemisphere having a second surface whose center of curvature is located at the first position; and

forming a plurality of sub-images of the scene, wherein each of the plurality of sub-images is formed by one of a plurality of second lenses that images a portion of the scene through the first lens, and wherein each of the plurality of second lenses has a unique optical axis.

**28.** The method of claim 27 wherein the first lens is provided such that the first lens element introduces a first aberration with a first magnitude on light that transits the first lens element, and wherein the first lens collectively introduces the first aberration with a second magnitude on light that transits the first lens, and further wherein the second magnitude is less than the first magnitude.

**29.** The method of claim 28 wherein the first lens is provided such that the first aberration is one of spherical aberration and chromatic aberration.

**30.** The method of claim 28 wherein the first lens is provided such that the first lens element introduces a second aberration with a third magnitude on light that transits the first lens element, and wherein the first lens collectively introduces the second aberration with a fourth magnitude on light that transits the first lens, and further wherein the fourth magnitude is less than the third magnitude.

**31.** The method of claim 30 wherein the first lens is provided such that the first aberration is spherical aberration and the second aberration is chromatic aberration.

**32.** The method of claim 27 wherein the first lens is provided such that the exit lens shell comprises a first shell layer and a second shell layer, and wherein the first shell layer and second shell layer are separated by an air gap.

**33.** The method of claim 27 wherein the first lens is provided such that the first lens element, entry lens shell, and exit lens shell are collectively apochromatic.

**34.** The method of claim 27 wherein the first lens is provided such that it comprises an optical stop.

**35.** The method of claim 27 wherein the first lens is provided such that the entry lens shell and exit lens shell are characterized by different refractive indices.

**36.** The method of claim 27 further comprising converting each of the plurality of sub-images into a digital representation of a portion of the scene.

**37.** The method of claim 36 further comprising forming a composite digital representation of the scene based on the plurality of digital representations.



FIG. 2

200 →

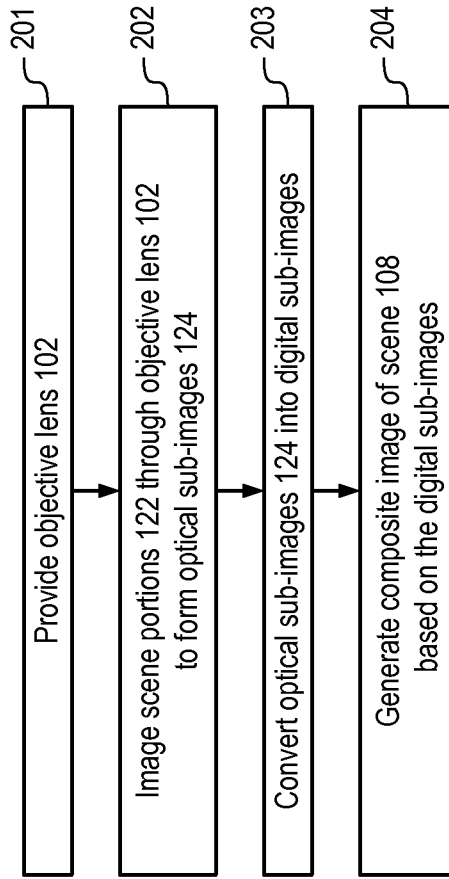

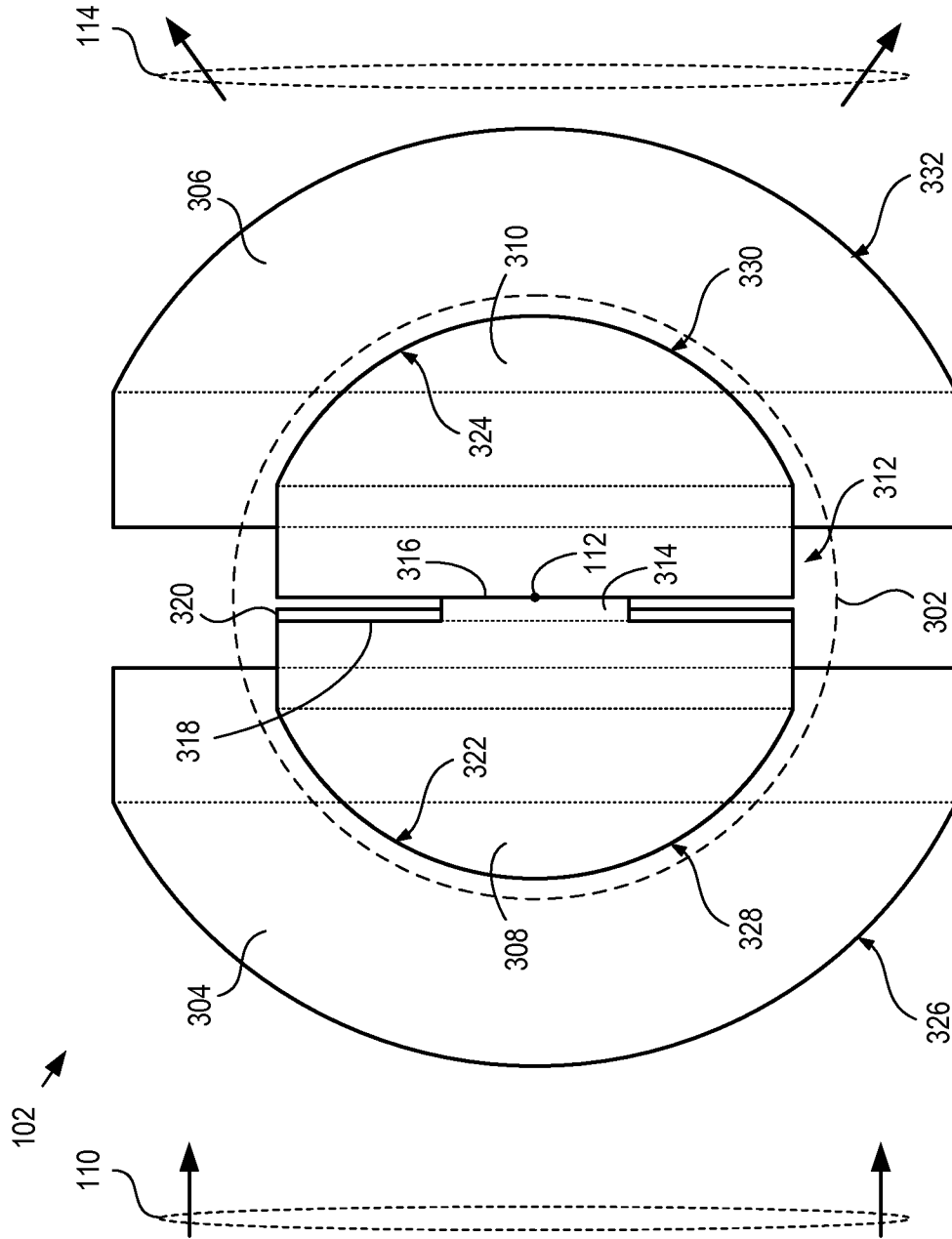
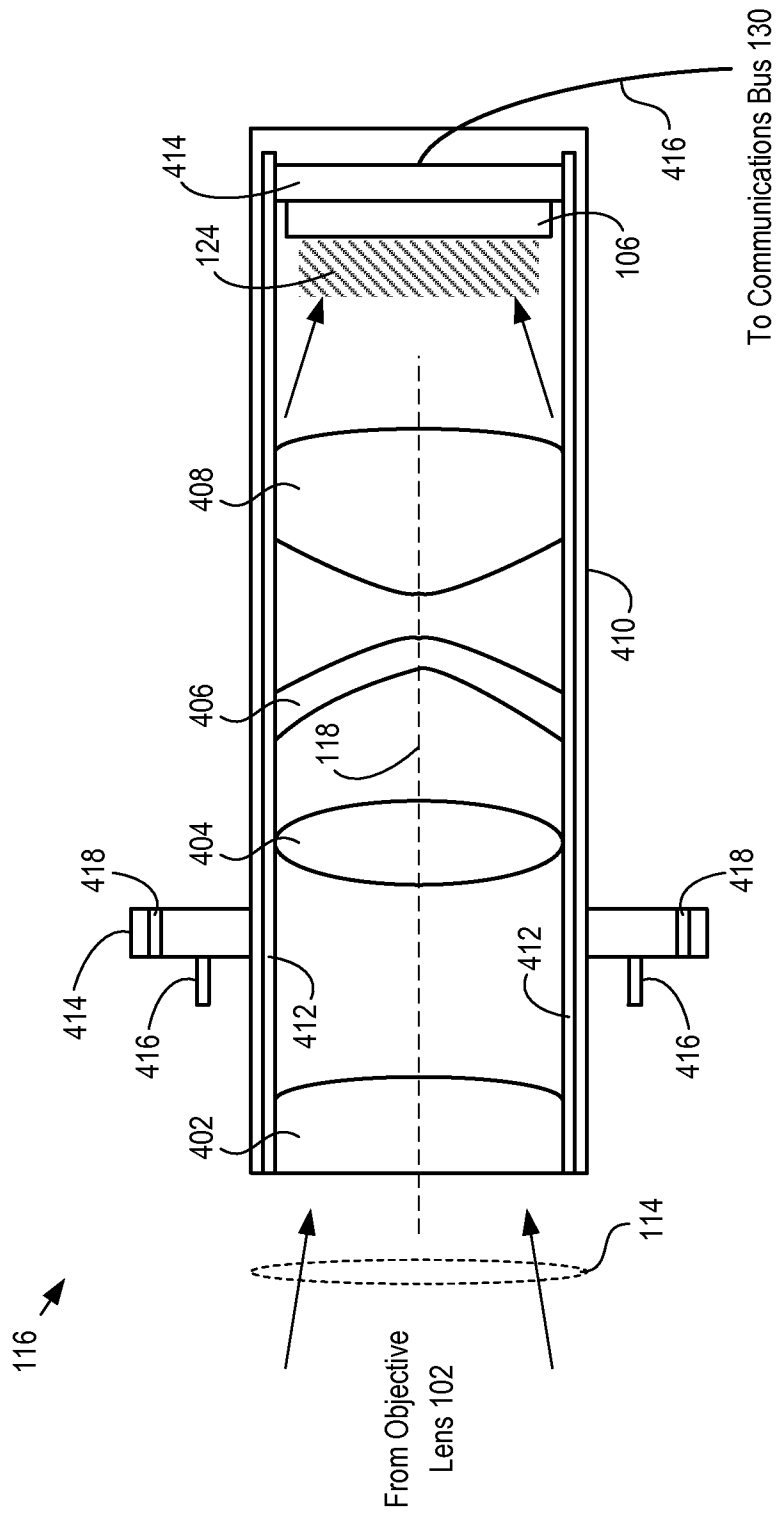
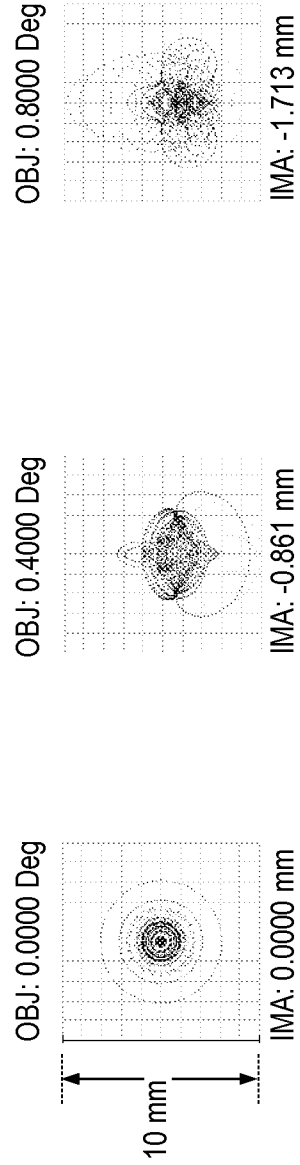
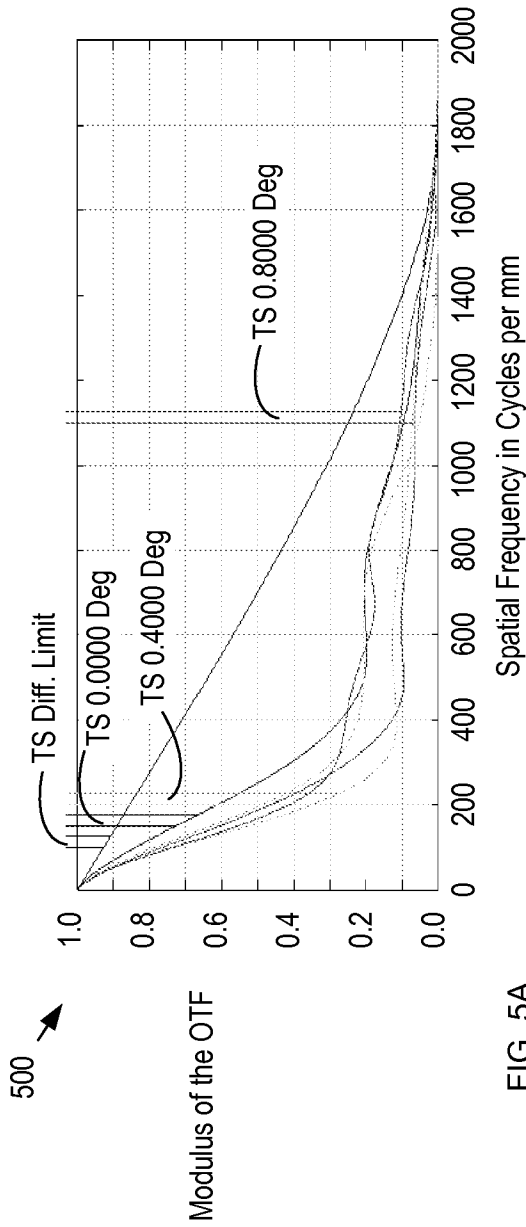

FIG. 3

FIG. 4





6/15

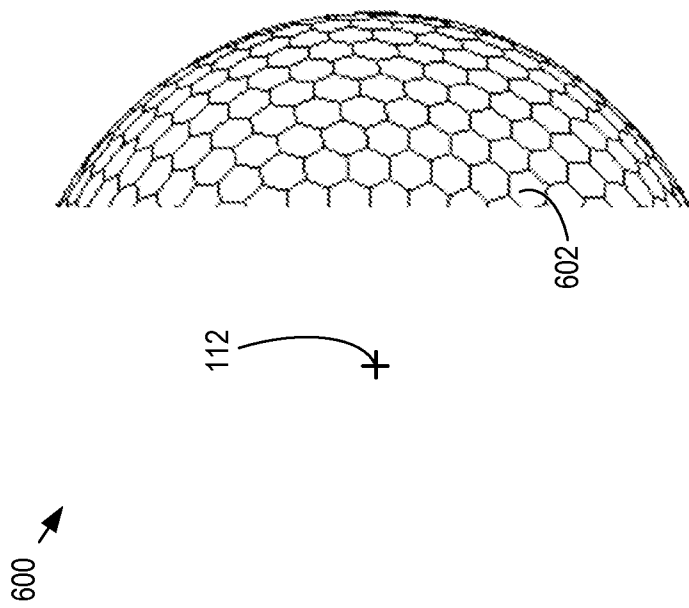

FIG. 6A

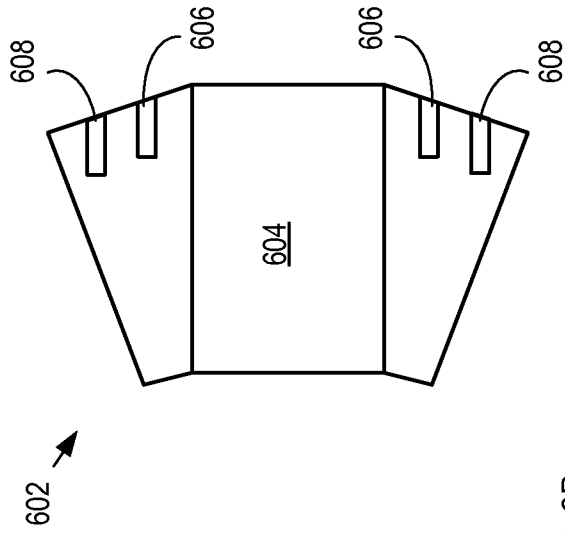

FIG. 6B

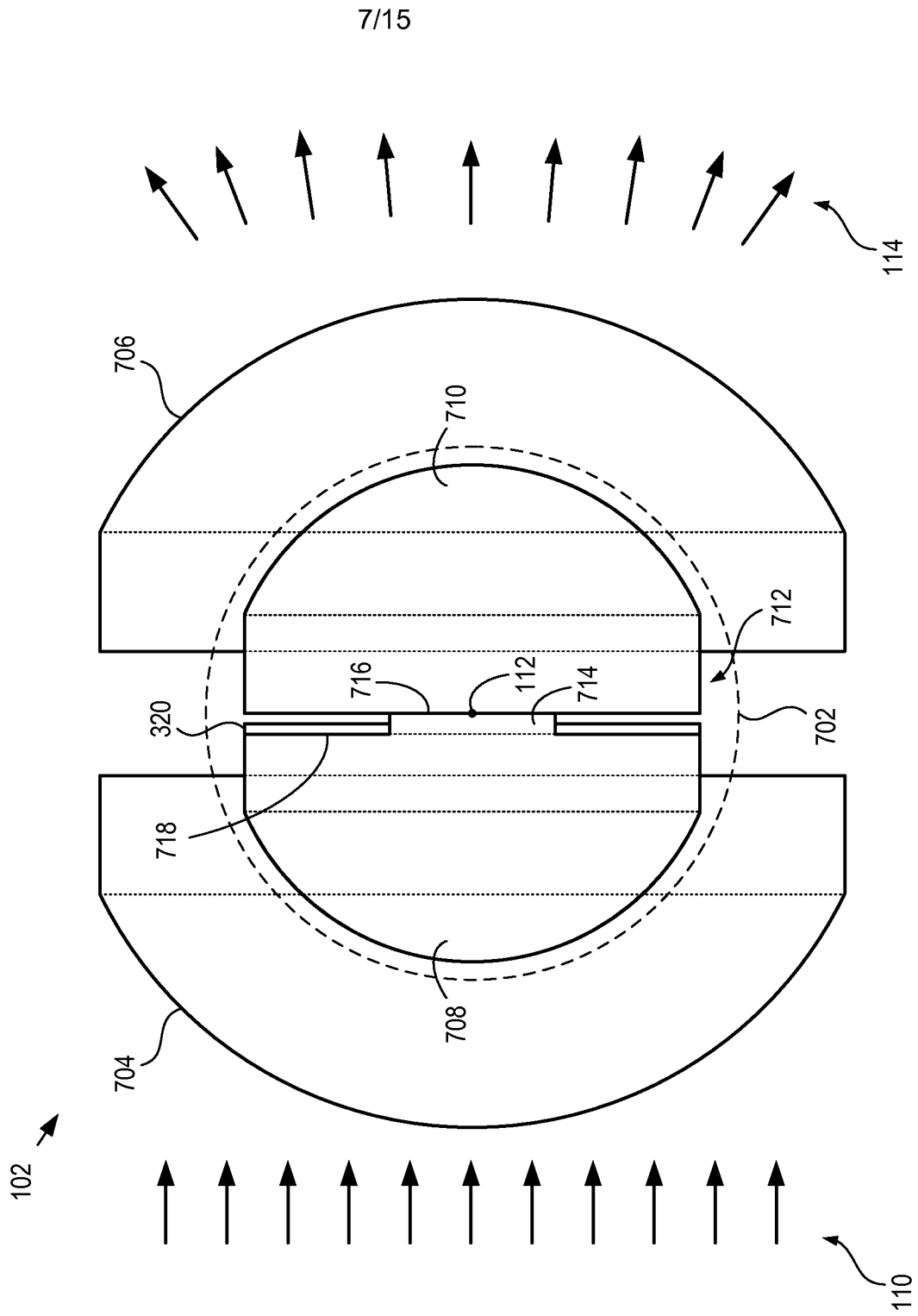
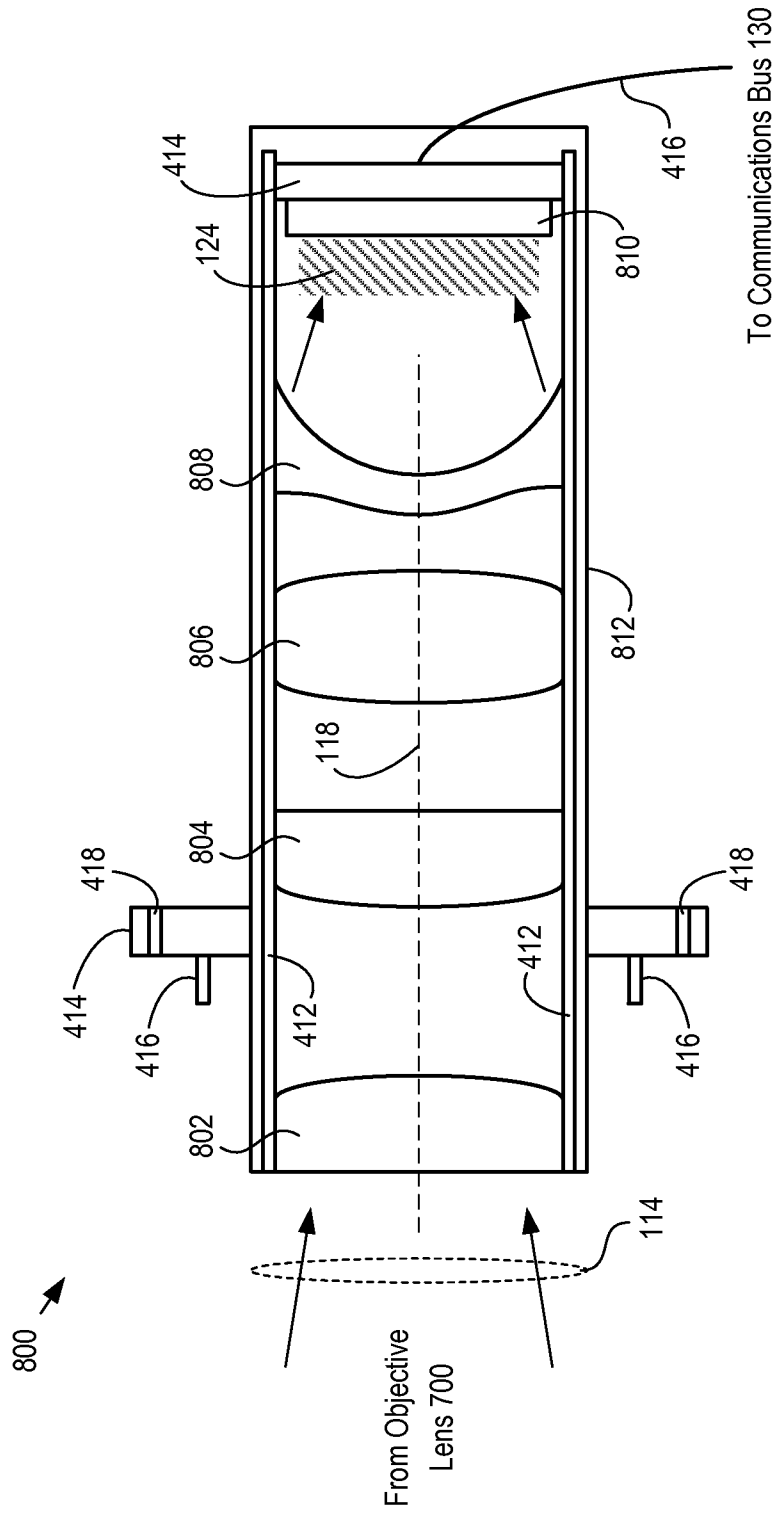
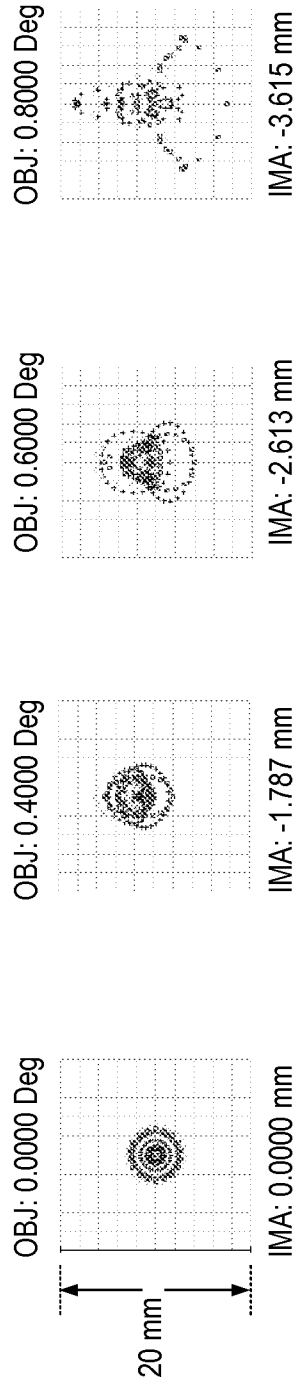
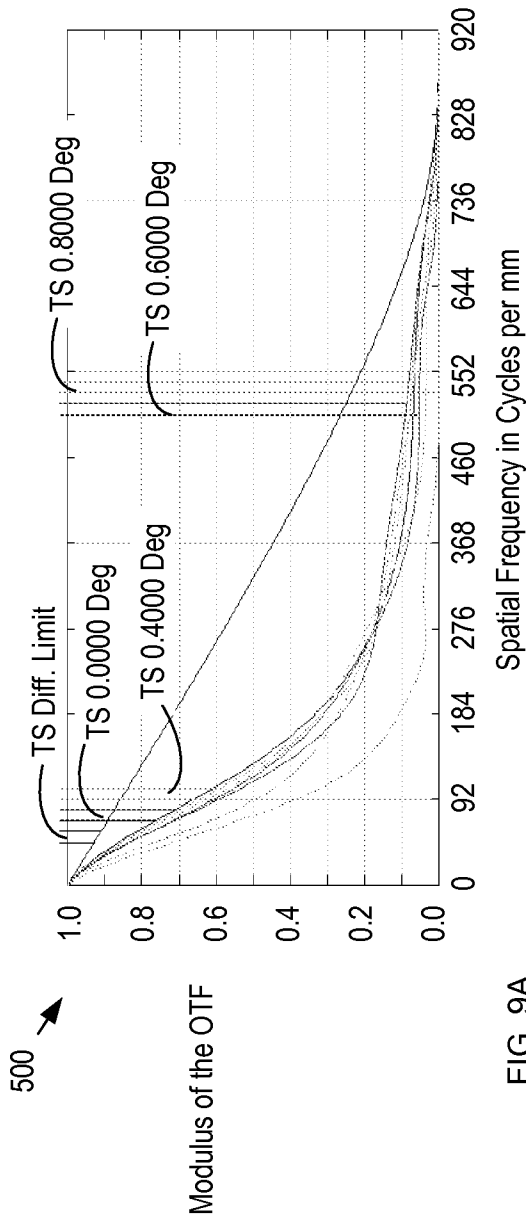
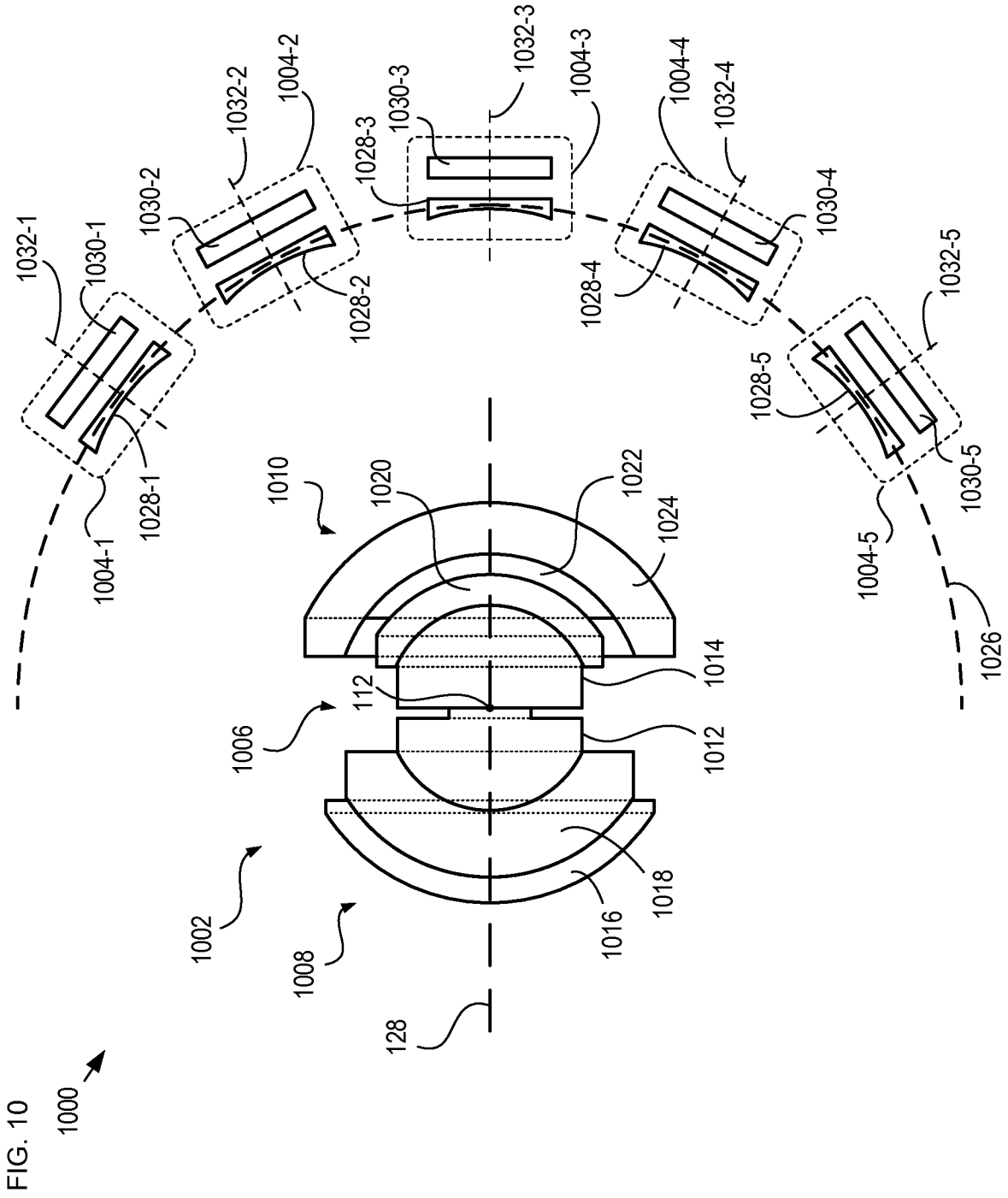

FIG. 7

FIG. 8







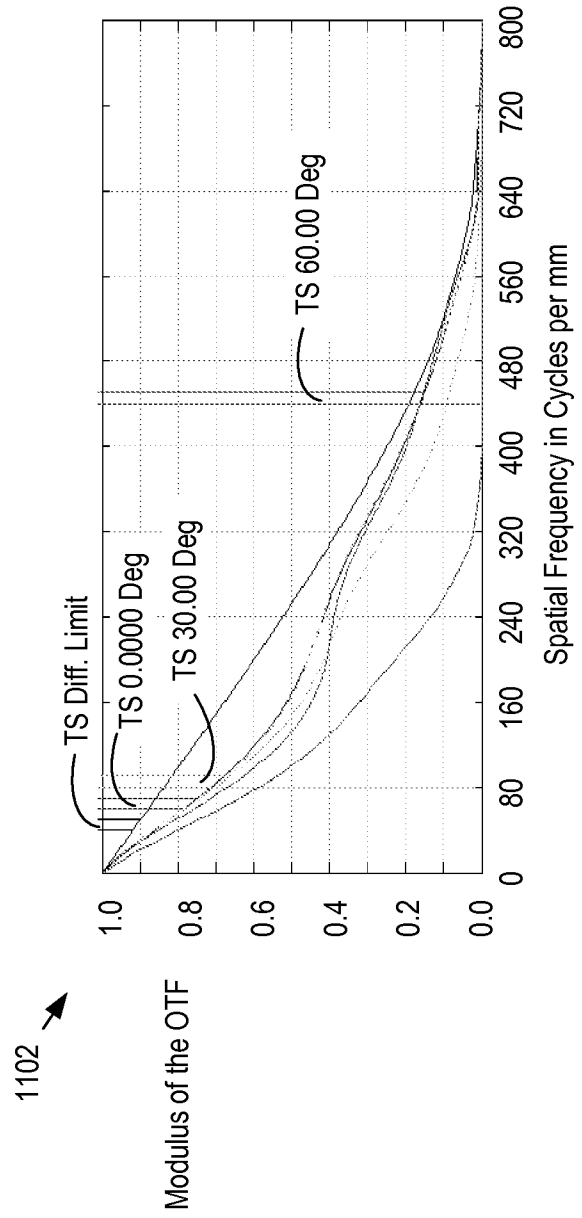
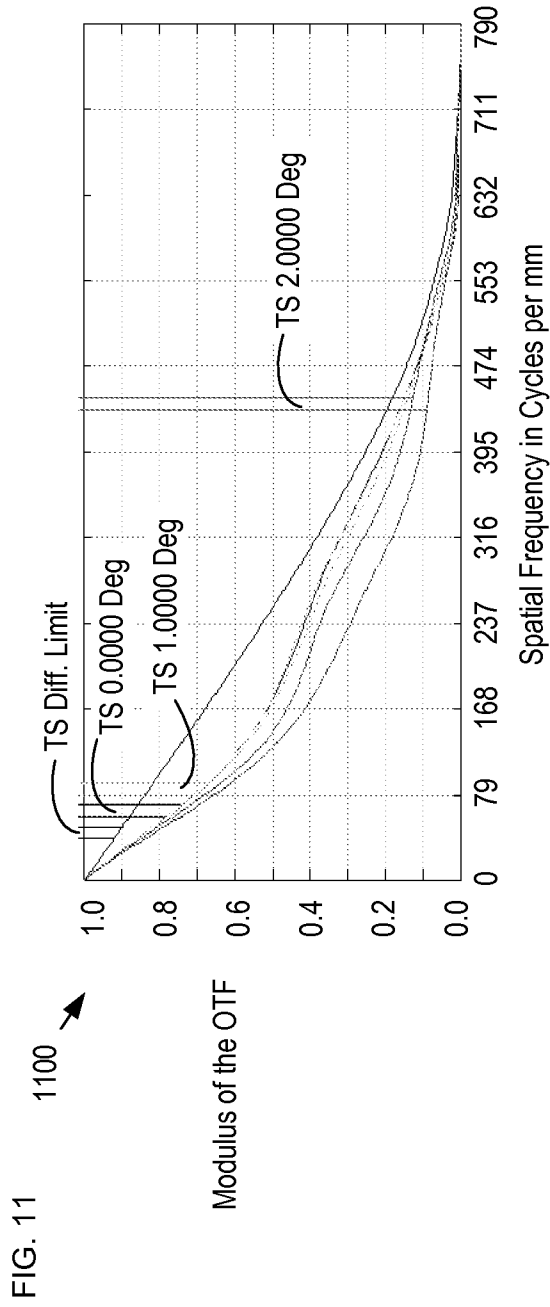

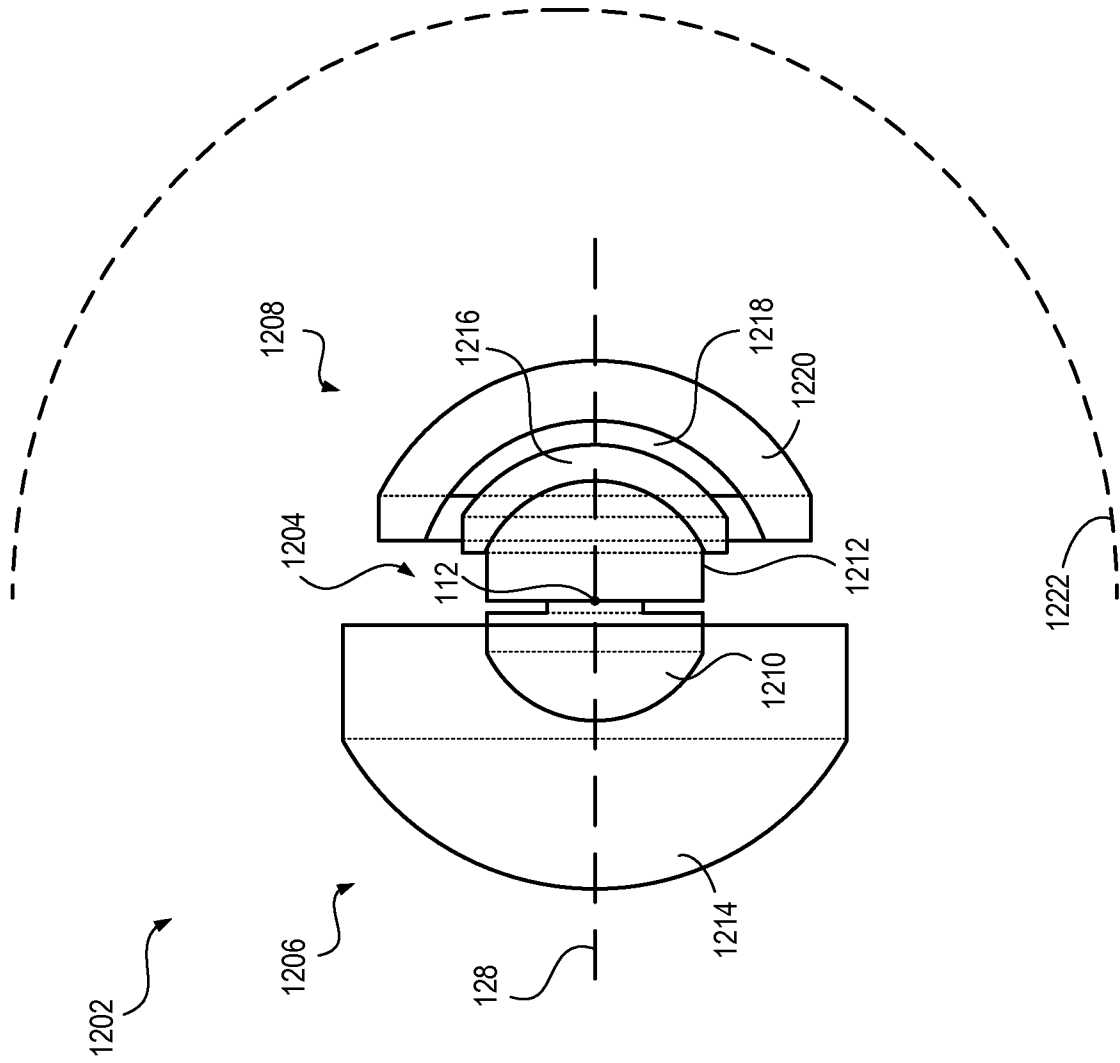
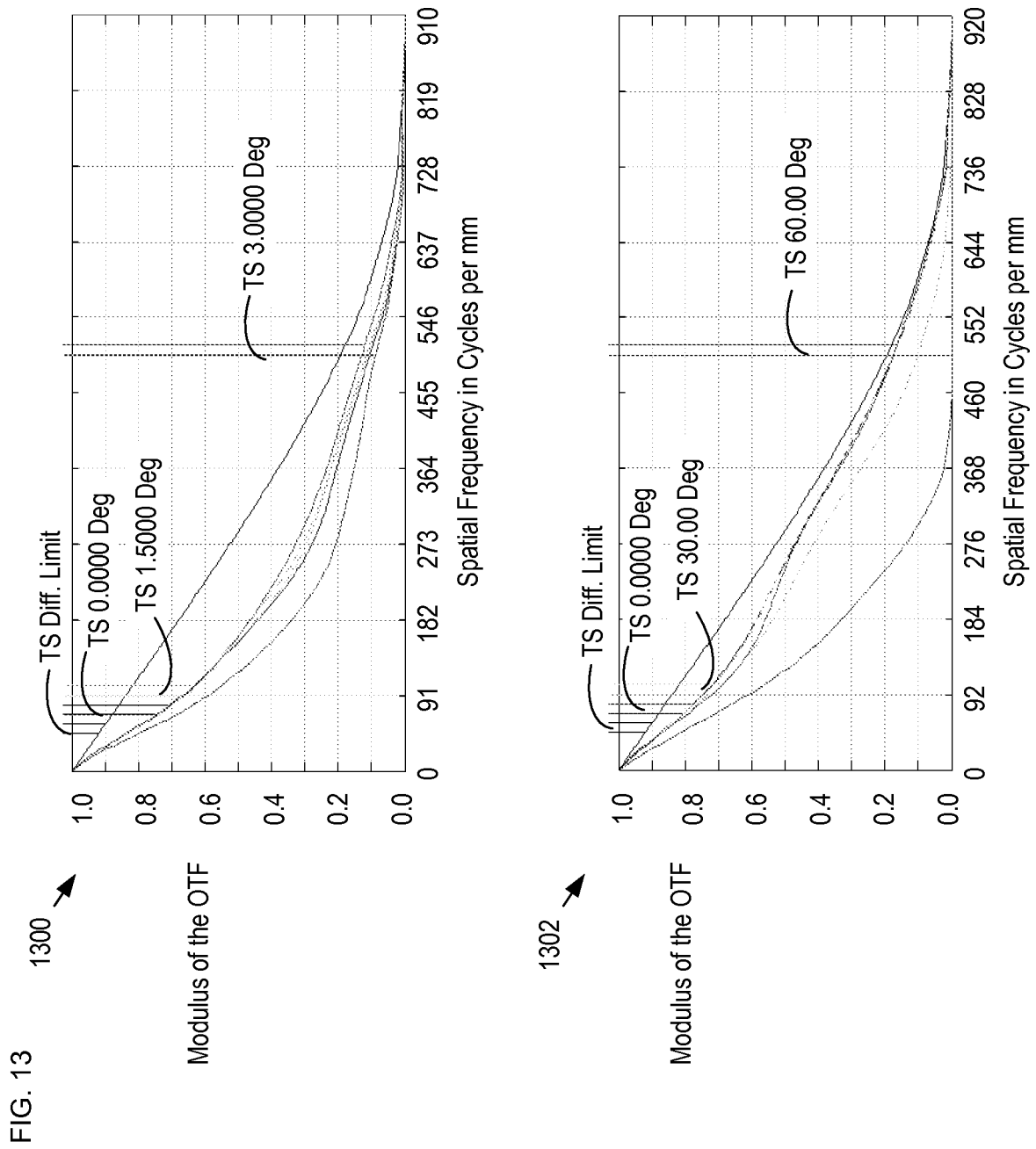

FIG. 12



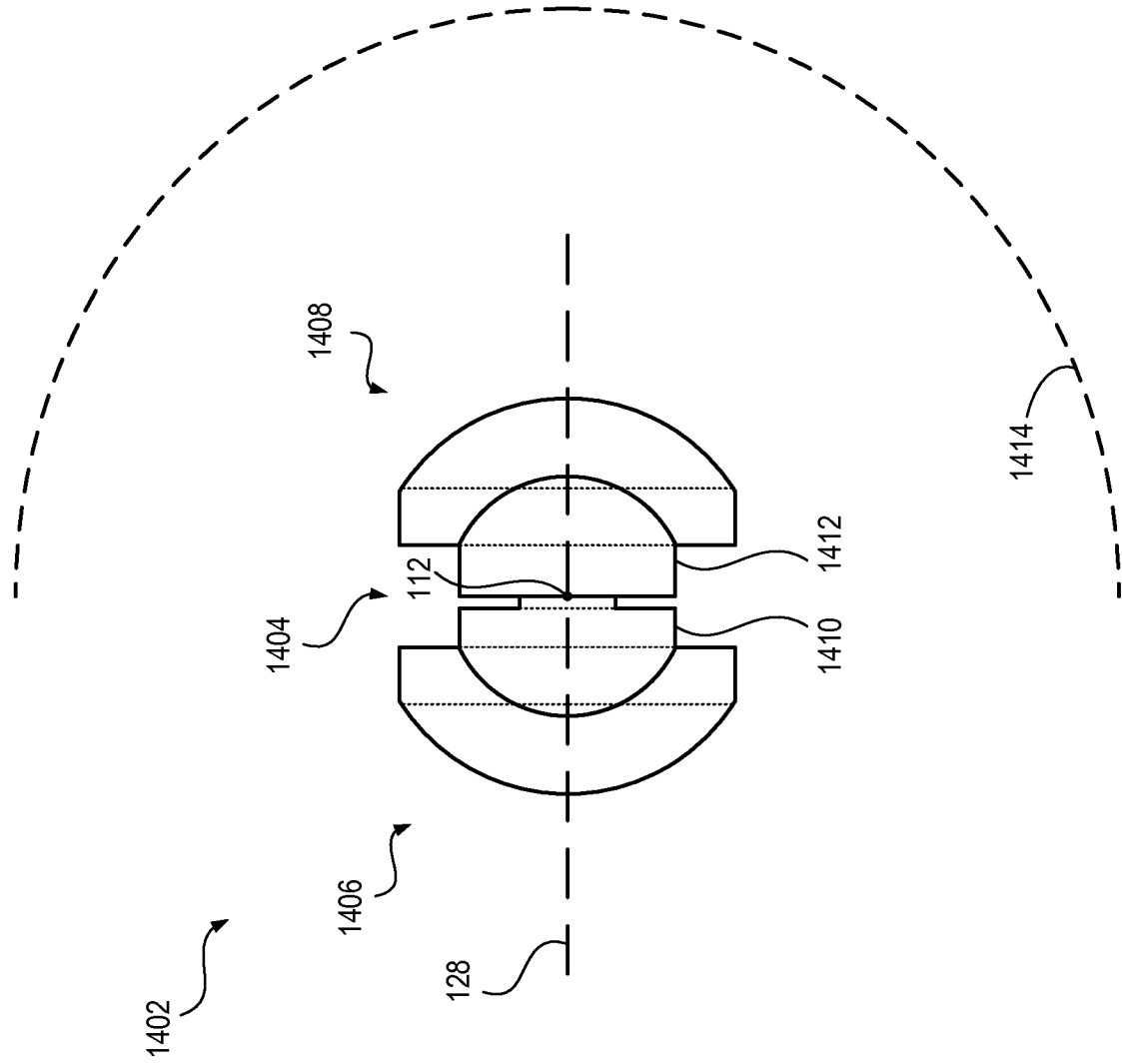
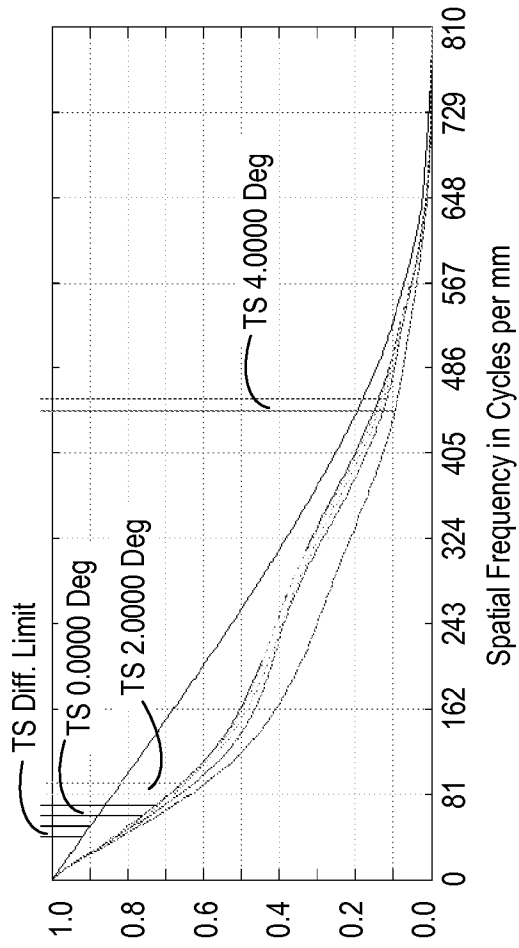
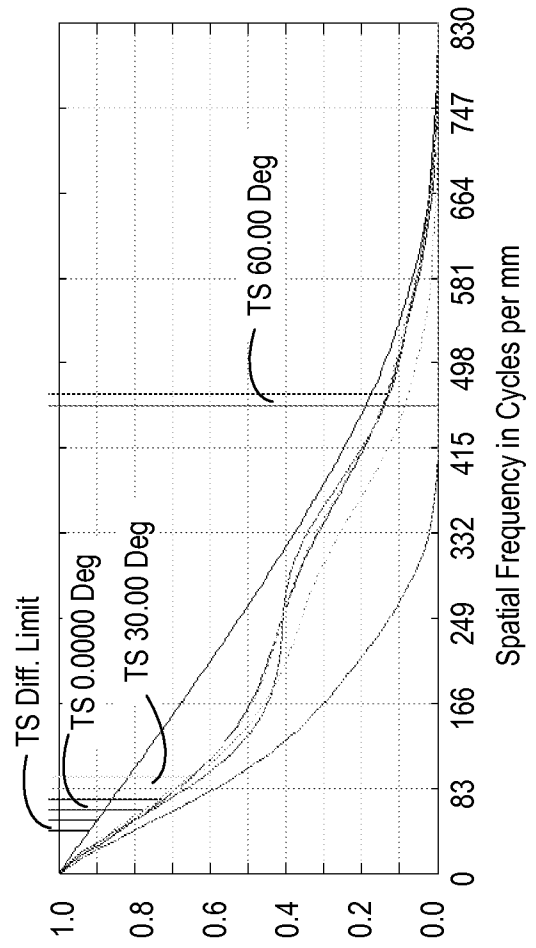

FIG. 14

FIG. 15 1500 →



1502 →



**INTERNATIONAL SEARCH REPORT**

International application No  
PCT/US2011/034156

A. CLASSIFICATION OF SUBJECT MATTER  
INV. G02B13/06 H04N5/225  
ADD.  
  
According to International Patent Classification (IPC) or to both national classification and IPC

B. FIELDS SEARCHED  
Minimum documentation searched (classification system followed by classification symbols)  
G02B H04N

Documentation searched other than minimum documentation to the extent that such documents are included in the fields searched

Electronic data base consulted during the international search (name of data base and, where practical, search terms used)  
EPO-Internal, WPI Data

C. DOCUMENTS CONSIDERED TO BE RELEVANT

Category*	Citation of document, with indication, where appropriate, of the relevant passages	Relevant to claim No.
X	WO 95/23349 A1 (GALLERT FRANK [DE]) 31 August 1995 (1995-08-31) figure 1	1-37
X	----- US 5 004 328 A (SUZUKI MASAYUKI [JP] ET AL) 2 April 1991 (1991-04-02) figures 17,18 column 4 - lines 15-49	1-37
A	----- US 2004/061787 A1 (LIU ZICHENG [US] ET AL) 1 April 2004 (2004-04-01) paragraph [0013] figure 4	1-37

Further documents are listed in the continuation of Box C.

See patent family annex.

\* Special categories of cited documents :

- "A" document defining the general state of the art which is not considered to be of particular relevance
- "E" earlier document but published on or after the international filing date
- "L" document which may throw doubts on priority claim(s) or which is cited to establish the publication date of another citation or other special reason (as specified)
- "O" document referring to an oral disclosure, use, exhibition or other means
- "P" document published prior to the international filing date but later than the priority date claimed

- "T" later document published after the international filing date or priority date and not in conflict with the application but cited to understand the principle or theory underlying the invention
- "X" document of particular relevance; the claimed invention cannot be considered novel or cannot be considered to involve an inventive step when the document is taken alone
- "Y" document of particular relevance; the claimed invention cannot be considered to involve an inventive step when the document is combined with one or more other such documents, such combination being obvious to a person skilled in the art.
- "&" document member of the same patent family

Date of the actual completion of the international search  8 August 2011	Date of mailing of the international search report  23/09/2011
--	--

Name and mailing address of the ISA/ European Patent Office, P.B. 5818 Patentlaan 2 NL - 2280 HV Rijswijk Tel. (+31-70) 340-2040, Fax: (+31-70) 340-3016	Authorized officer  Quertemont, Eric
--	--

# INTERNATIONAL SEARCH REPORT

Information on patent family members

International application No

PCT/US2011/034156

Patent document cited in search report	Publication date	Patent family member(s)	Publication date
WO 9523349	A1 31-08-1995	AU 6154094 A EP 0753162 A1 JP 9509265 T	11-09-1995 15-01-1997 16-09-1997
-----			
US 5004328	A 02-04-1991	NONE	
-----			
US 2004061787	A1 01-04-2004	US 2006209194 A1	21-09-2006
-----			