

(No Model.)

3 Sheets—Sheet 1.

L. AFF & W. JORDANS.
Baking Oven.

No. 237,461.

Patented Feb. 8, 1881.

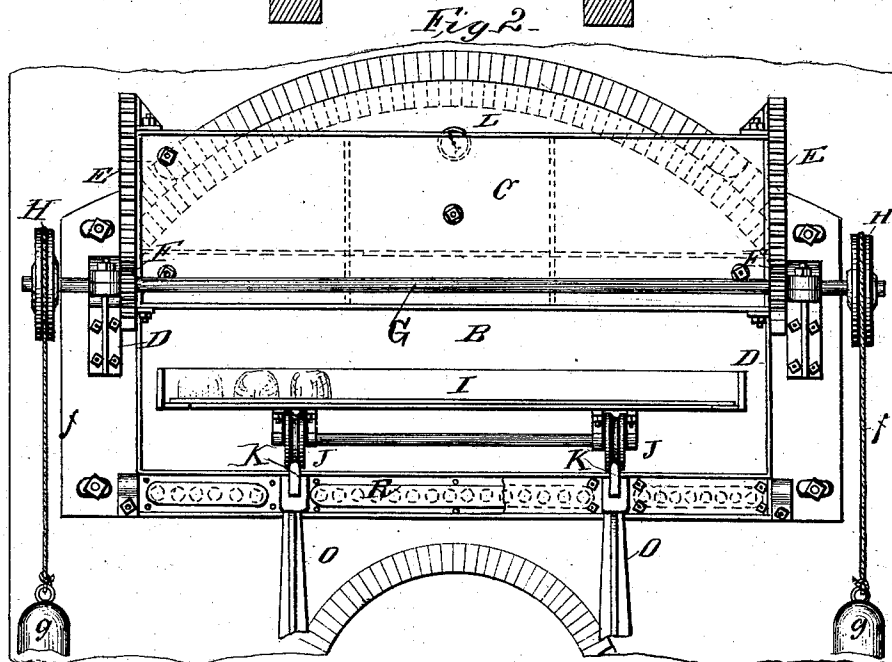
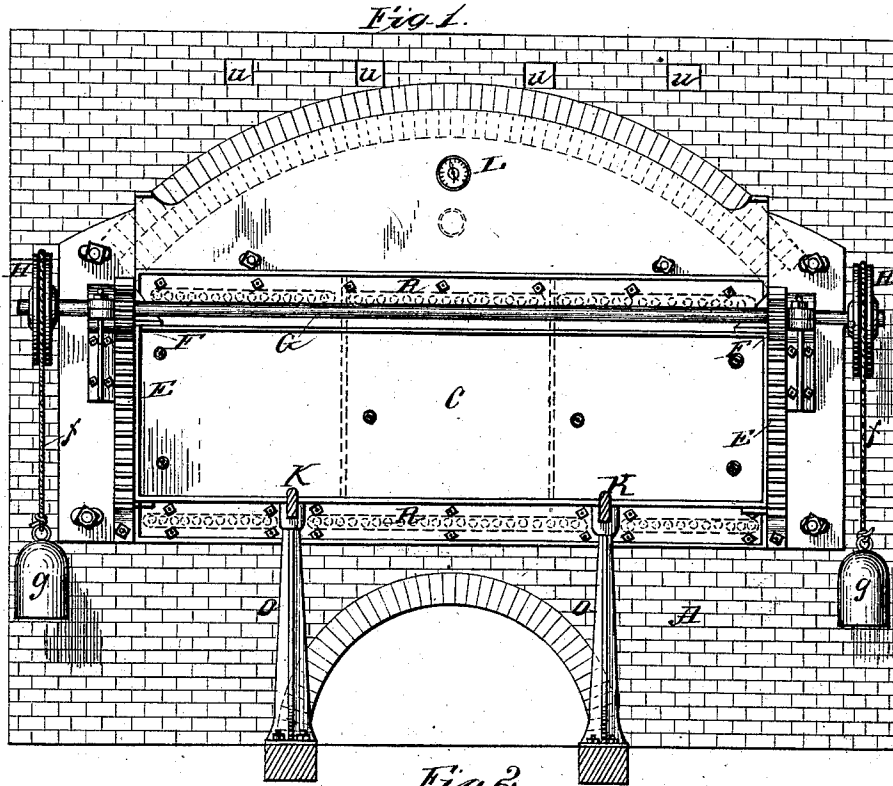

Witnesses:
E. Glanzer
J. C. Peck

Inventor:
Louis Aff
Wilhelm Jordans
 By *Jas. P. Emme*
 Attorney-

(No Model.)

3 Sheets—Sheet 2.

L. AFF & W. JORDANS.
Baking Oven.

No. 237,461.

Patented Feb. 8, 1881.

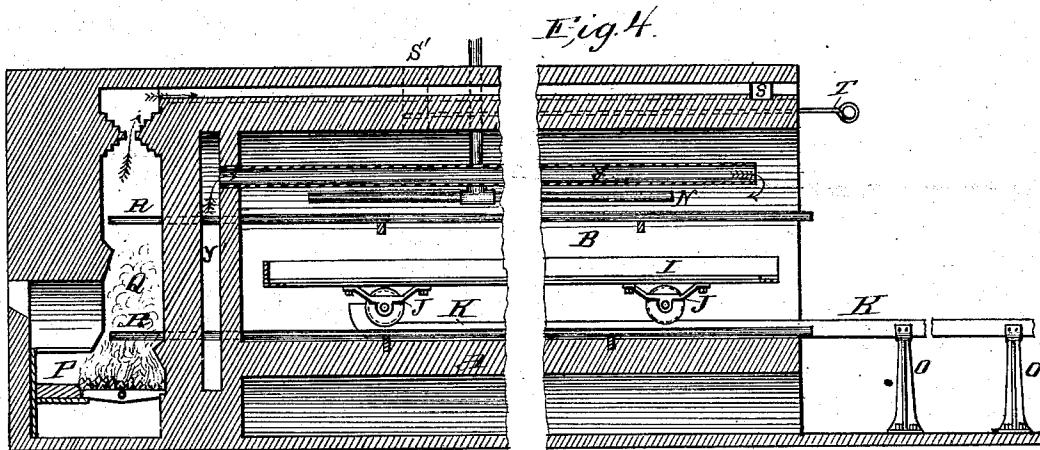
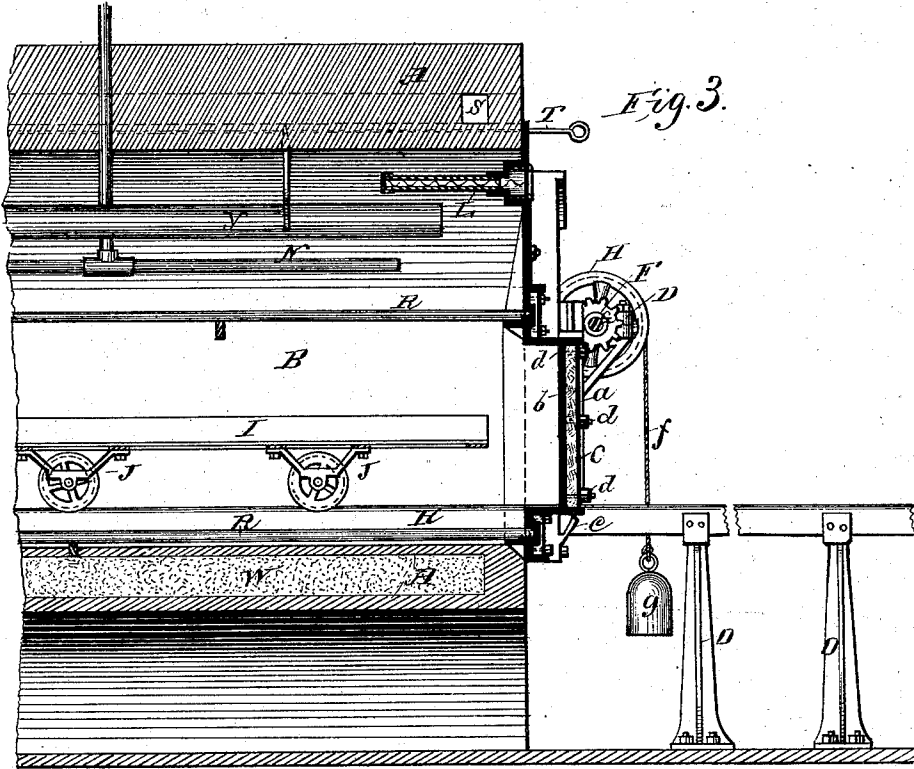

Witnesses:

E. Allomus
J. C. Peck

Inventors,
Louis Aff
Wilhelm Jordans
By *pat. B. Ennis.*

Attorney-

(No Model.)

9 Sheets—Sheet 3.

L. AFF & W. JORDANS.
Baking Oven.

No. 237,461.

Patented Feb. 8, 1881.

Fig. 5.

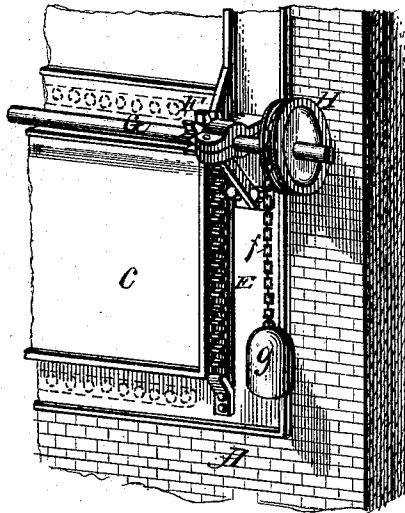

Witnesses:

E. L. Ames
J. B. Peck

Inventors:

Louis Aff
Wilhelm Jordans
By Jas. B. Erwin
Attorney.

UNITED STATES PATENT OFFICE.

LOUIS AFF AND WILHELM JORDANS, OF MILWAUKEE, WISCONSIN, ASSIGNORS OF ONE-THIRD TO F. F. RIEDEL MANUFACTURING COMPANY, OF SAME PLACE.

BAKING-OVEN.

SPECIFICATION forming part of Letters Patent No. 237,461, dated February 8, 1881.

Application filed October 13, 1880. (No model.)

To all whom it may concern:

Be it known that we, LOUIS AFF and WILHELM JORDANS, citizens of the United States, residing at Milwaukee, in the county of Milwaukee and State of Wisconsin, have invented certain new and useful Improvements in Baking-Ovens; and we do hereby declare the following to be a full, clear, and exact description of the invention, such as will enable others skilled in the art to which it appertains to make and use the same, reference being had to the accompanying drawings, and to letters or figures of reference marked thereon, which form a part of this specification.

Our invention relates to improvements in baking-ovens; and it consists, first, in a device for generating and conveying heat to the interior of the oven; second, a device for hermetically closing the oven, whereby the air contained therein is prevented from escaping as it is expanded by heat, and the contents of the oven are baked under pressure and with less heat than would otherwise be required; third, a device for opening and closing the oven-door and passages for ventilating and heating, as hereinafter set forth.

Our invention is further explained by reference to the accompanying drawings.

Figure 1 represents a front view with door closed. Fig. 2 is a front view with door open. Fig. 3 represents a sectional side view of the front part of the oven. Fig. 4 represents a sectional side view, showing the fire-box or combustion-chamber and flues. Fig. 5 is a detail view of the door-elevating mechanism.

A is a substantial brick wall which supports and surrounds the oven. B is the oven. C is the oven-door, which is constructed of two sheet-metal plates, *a b*, secured together by bolts *d d*, between which plates is a packing of mineral wool, which is inserted to prevent the escape of heat. The front of the oven is provided with a nicely-smoothed plate, D, to which the door C is closely fitted, so that when closed it forms an air-tight bearing, which prevents the escape of the heated air from the oven. The respective ends of the door C are provided with toothed bars EE, which are respectively geared into pinions FF. Pinions

FF are rigidly secured to the respective ends of shaft G.

HH are pulleys, which are also rigidly secured to shaft G, and are each provided with cords *f f* and weights *g g*, which weights counterbalance the door C. Thus as the weights are drawn down they act through the pulleys, causing the shaft and pinions to revolve, when the pinions engage in the toothed bars, causing the door to rise. The weights also counterbalance and retain the door wherever adjusted.

I is the sliding table. It is provided with rollers J J J J and track K, whereby the table is easily moved into and from the oven.

L is a pyrometer of ordinary construction, by which the heat-pressure and progress of baking is ascertained.

N is a perforated tube, which is connected upon the outside of the oven with a steam-generator, from which it conducts steam to the interior of the oven, when it escapes through the perforations and produces the necessary moisture for glazing the bread, &c.

OOO are standards for supporting the exterior ends of the track.

P is the combustion-chamber. It is provided with an angular flue, Q, so formed to retard the escape of heat, and the upper end of the flue is contracted for the same purpose.

RR are series of hermetically-sealed steam-pipes, which extend lengthwise across the oven from one end to the other, respectively arranged one above and one below the bread-table. The rear ends of the series of pipes extend through the wall of the oven into the fire-box or combustion-chamber and flue. A small quantity only of water is used in the steam-pipes, which is introduced before closing them. When fire is applied the entire quantity of water is converted into steam, which is superheated to a high degree of temperature, when the steam conveys the heat through the sections of pipes to the interior of the oven. Thus the same water may be reconverted into steam and condensed an indefinite number of times.

S' is a tube which communicates from the interior to the exterior of the oven for purposes of ventilation. It is provided with an ordinary

stop-cock or damper, which is operated by rod T. The products of combustion are conducted forward from the combustion-chamber over the oven in flues U U U U. A greater or less number may be used, as desired, several, however, being preferred to one, as they serve to convey the heat more uniformly over the oven.

W is a layer or bed of sand arranged beneath the floor of the oven for the purpose of more effectually retaining the heat.

Y is an air space or passage, which is heated by the fire in the combustion-chamber through the intermediate wall, when the heat passes into the oven in the course indicated by the arrows.

S is a smoke passage or flue, which extends across the front ends and forms a communication between the flues U.

Having thus described our invention, what we claim as new, and desire to secure by Letters Patent, is—

1. The improvements in baking-ovens herein described, consisting in one or more series of hermetically-sealed steam-pipes provided with a supply of water or other liquid, arranged with one end in the oven, and extending from thence through the walls of the oven into the

combustion-chamber, as adapted to generating and conducting superheated steam within the pipes to the interior of the oven, substantially as and for the purpose specified.

2. The combination of door C, toothed bars E E, pinions F F, shaft G, pulleys H H, cords *f f*, and weights *g g*, as set forth.

3. The improvements in baking-ovens herein described, consisting in the combination and arrangement of combustion-chamber P, having angular flues Q, hermetically-sealed steam-pipes R extending from the combustion-chamber through the wall to the inside of the oven, all substantially as and for the purpose specified.

4. The oven B, provided with hermetically-sealed steam-pipes R, perforated steam-pipes N, escape or ventilation pipe S', sand-bed W, hot-air passage Y, and pyrometer L, all combined and arranged substantially as set forth.

In testimony whereof we affix our signatures in presence of two witnesses.

LOUIS AFF.

WILHELM JORDANS.

Witnesses:

E. G. ASMUS,

JAS. B. ERWIN.