

March 15, 1966

A. J. HORSTMAN

3,240,437

REFINER PLATE

Filed June 17, 1963

2 Sheets-Sheet 1

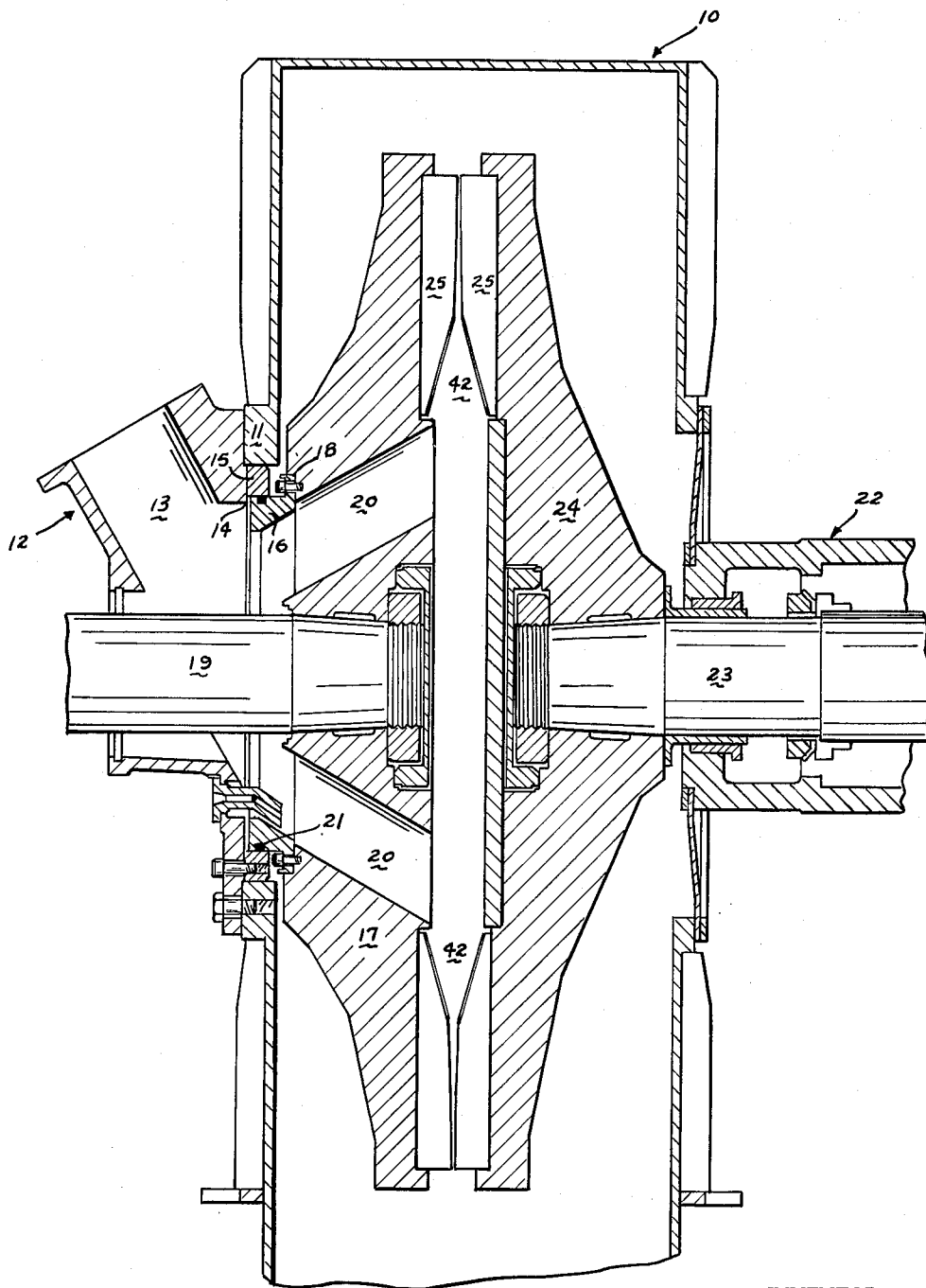

Fig-1

INVENTOR.
ANTON J. HORSTMAN
BY Tom Walker
ATTORNEY

March 15, 1966

A. J. HORSTMAN

3,240,437

REFINER PLATE

Filed June 17, 1963

2 Sheets-Sheet 2

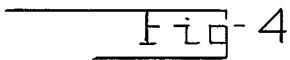
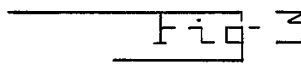
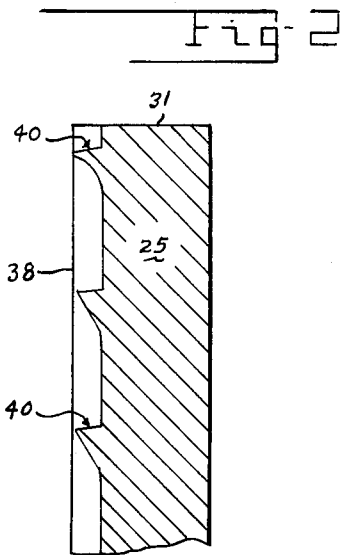
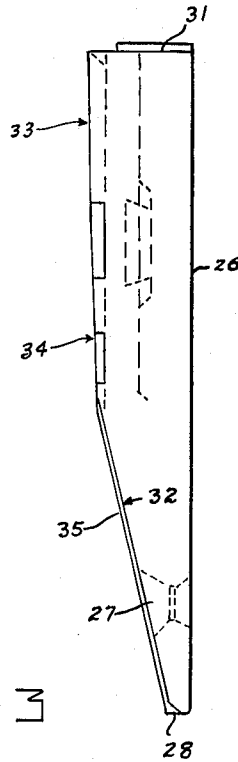
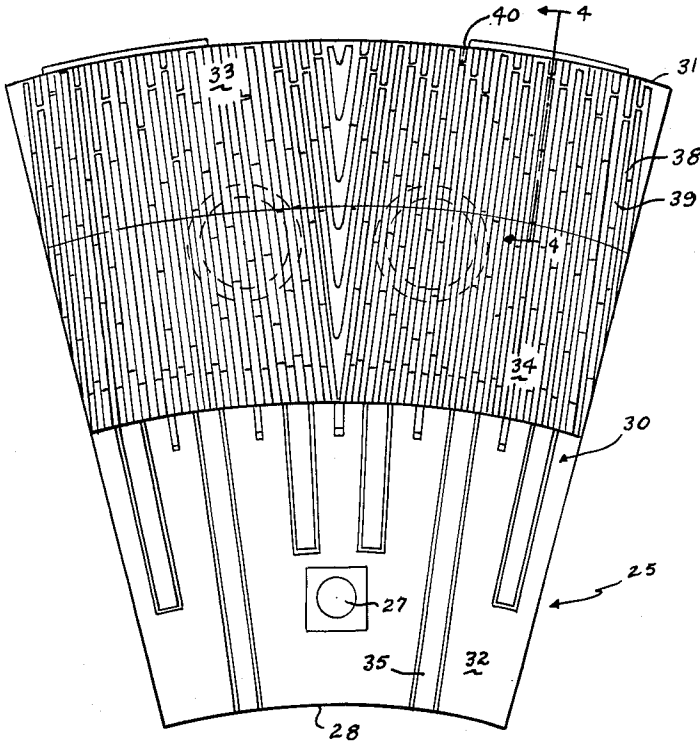

INVENTOR
ANTON J. HORSTMAN
BY Tom Walker
ATTORNEY

3,240,437

REFINER PLATE

Anton J. Horstman, Houghton, Mich., assignor to Bauer Bros. Co., Springfield, Ohio, a corporation of Ohio
 Filed June 17, 1963, Ser. No. 288,148
 7 Claims. (Cl. 241-251)

This invention relates to pulp refiners and more particularly to improvements in refiner plates.

A primary object of the invention is to provide a pulp refiner which is economical to fabricate, more efficient and satisfactory in use, adaptable to a wide variety of applications, and unlikely to malfunction.

Another object of the invention is to provide a refiner plate which is particularly advantageous for use in refining pulp.

A further object of the invention is to provide a refiner plate having an improved capability of reducing wood chips to individual fibers without cutting the fibers.

An additional object of the invention is to provide improvements in double disc refiners rendering them capable of achieving optimal performance with minimal size refiner plates.

Another object of the invention is to provide a pulp refining plate so designed to reduce the normal anticipated wear factor.

A further object of the invention is to provide a pulp refiner, the refining elements of which are so formed to produce improved pulp products with less expenditure of energy than would be normally anticipated.

An additional object of the invention is to provide an improved refiner plate having an operating surface which is gradually sloped substantially from one end to the other.

A further object of the invention is to achieve an improved double disc pulp refiner including opposed relatively rotating refining surfaces so designed to provide a gently graduated refining throat which facilitates the proper orientation of materials which pass therebetween and reduces wood chips by a rolling rather than a cutting action thereon.

Another object of the invention is to provide an improved refiner plate having an operating surface including refiner bars which are primarily located in its outer peripheral area.

A further object of the invention is to provide a refiner plate including a gradual entrance slope which extends substantially one-half its operative length and incorporates shallow widely spaced distributor bars of substantially uniform depth.

An additional object of the invention is to provide a pulp refiner comprising means defining a flow path for fibrous particles which produce a rolling of the particles to orient their fibers in a sense longitudinally of their flow path and apply a gradually increasing compressive force to loosen the relative adherence of the fibers in each particle as the particles flow thereby, achieving a degree of compression that the fibers of each particle will physically separate on relief of the compressive force.

A further object of the invention is to provide an improved refiner plate possessing the advantageous structural features, the inherent meritorious characteristics and the mode of operation herein mentioned.

With the above and other incidental objects in view as will more fully appear in the specification, the invention intended to be protected by Letters Patent consists of the features of construction, the parts and combinations thereof, and the mode of operation as hereinafter described or illustrated in the accompanying drawings, or their equivalents.

Referring to the accompanying drawing wherein is

shown one but obviously not necessarily the only form of embodiment of the invention,

FIG. 1 of the drawings is a fragmentary cross-sectional view of a disc refiner incorporating features of the present invention;

FIG. 2 is a plan view of the refiner plate utilized in the structure of FIG. 1;

FIG. 3 is a side elevation view of the plate shown in FIG. 2; and

FIG. 4 is a fragmentary cross-sectional view taken on line 4-4 of FIG. 2.

Like parts are indicated by similar characters of reference throughout the several views.

The disc refiner in the drawings is detailed only to the extent necessary for the disclosure of the present invention. As shown, it includes a housing 10 having an opening to one side defined by a tubular projection 11. Bolted to the outer face of the projection 11 is a feed spout 12 including a flow passage 13 in communication with the opening. The delivery end of the flow passage 13 is defined by a short tubular spout projection 14 which nests in peripheral contacting relation to the projection 11.

Fixed within the projection 11, in end abutting relation to the spout projection 14, is a first ring element 15. A second ring element 16 is bolted to the rear of an adjacent open disc 17 through the medium of a peripherally projected flange 18. The ring 16 relatively projects to concentrically nest in the ring 15, in closely spaced relation thereto. The disc 17, which mounts in the housing 10 to one end of a drive shaft 19, includes flow passages 20 the entrance ends of which are rimmed by the ring element 16. The passages 20 conically orient about the shaft 19 to relatively diverge from their entrance ends which are adjacent and spaced from the opening defined by the projection 11. Drive shaft 19 extends through the projection 11 and an opening in one side of the spout 12 which leads thereto.

A ring seal 21 nests in and relatively projects from the outer periphery of ring 16 to contact the inner periphery of the ring 15 thereabout and form a seal therebetween. The ring 16 is so oriented that together with the ring 15 it forms a bridging flow passage connecting the spout delivery passage 13 and the divergent flow passages 20 in the open disc.

At its side opposite the projection 11, coaxial therewith, the housing 10 has a further opening defined by a bearing unit 22. The bearing unit 22 accommodates a drive shaft 23 one end of which terminates in the housing 10 to mount a closed disc 24 adjacent and relatively opposite the open disc 17. Each of the respectively adjacent faces of the discs 17 and 24 is provided with an identical annular recess nesting a series of identically formed refiner plates 25. The plates 25 are fixed in end abutting relation to provide the disc elements 17 and 24 with opposed, relatively adjacent ring shaped refining surfaces of a character to be further described.

Not here shown but connected to each of the shafts 19 and 23 are suitable drive means. These drive means may be conventionally energized to produce a relative rotation of the discs 17 and 24.

Since each of the plates 25 is identical, only one need be described by way of example. The plate 25 has a conventionally formed back 26 to abut the disc surface to which it mounts and includes a bolt hole 27 positioned adjacent and centrally of its inner arcuate extremity 28. The hole 27 accommodates a bolt 29 by means of which the plate may be removably fixed to the disc to which it mounts. The plate operating surface 30 is formed with a substantially continuous slope from its inner arcuate extremity 28 to its outer arcuate extremity 31. The surface 30 includes what may be classed as an entrance section 32,

an exit section 33 and an intermediate section 34 therebetween.

The radial extent of the section 32 is almost one-half that of the plate 25. The section 32 commences at the inner arcuate extremity of plate 25 in a position relatively adjacent the back 26 to move outwardly therefrom in a long, gradual, relatively uniform slope which merges with that of the intermediate section 34. Formed integral with the sloped surface of the section 32 are radially oriented, relatively wide, generally rectangular distributor bars 35. The bars 35 are widely spaced, relatively shallow and generally uniform in depth from one end to the other. Thus, the bars 35 are only slightly emergent from the base surface of the section 32 and their projected surface portions form a slope which smoothly merges with the profile of the slope of the intermediate section 34.

The section 34 of the plate operating surface also slopes outwardly relative the back 26 but to a lesser degree than the section 32. The slope of the exit section 33 is of an even lesser degree than that of the intermediate section so as to approach a flat at the radial extremity 31 of the plate 25.

The operating surface at the sections 33 and 34 is formed by the projected surfaces of narrow refiner bars 38 which are relatively closely spaced to form narrow feed channels 39 therebetween. The channels 39 are bridged at longitudinally spaced intervals by dams 40. The advance faces of the dams 40 are relatively sloped in the direction of the outer radial extremity of the plate 25 and their projected extremities terminate short of the plate operating surface as defined by the refiner bars 38. However, the dam 40 in each of the channels 39 which is radially outermost and positioned at the radial extremity 31 of the plate 25 projects to the operating plane of the refiner bars 38.

Thus, the profile of the operating surface 30 of each of the plates 25 is such to provide it with three relatively inclined sections, beginning with a long gradual slope forming an entrance section which is followed by slopes of successively lesser degree having a limited radial extent. It should be noted that a relatively flattened portion is not achieved on the plate operating surface except at its outer radial extremity. The slopes of the successive sections 32, 34 and 33 are so related as to approach an arc, successive sections of which have slightly different radii.

A refiner plate in accordance with the concepts of the present invention totally lacks any abruptly projected bar structure.

Looking to FIG. 1 of the drawings, the plates 25 may be seen in installed relation on the adjacent faces of the relatively rotatable discs 17 and 24. So installed they provide opposed, relatively projected annular refining surfaces. These surfaces are so formed to define a refining throat 42 therebetween the profile of which is substantially smoothly convergent from its inner to its outer radial extremity. The entrance to this refining throat immediately rims the outer peripheral portions of the flow passages 20 in the disc 17.

Observing the details of the throat 42, it may be seen to essentially consist of three portions, respectively defined by opposed refiner plate sections 32, 34, and 33. The opposed sections 32 provide an entrance portion which extends approximately one-half its operative length. This entrance portion has a relatively wide divergence at the point of entry and is free of abrupt projections which would interfere with a steady flow of stock therethrough.

Stock is introduced through the medium of the flow passages 13 and 20 to flow between the discs 17 and 24 and be centrifugally dispersed to the throat 42 thereby on their relative rotation.

In a preferred application of the invention structure to the refining of fibrous stock, as fibrous particles flow through the entrance portion of throat 42 on relative rotation of the discs 17 and 24, the relative length of the

entrance portion as well as its gradual convergence provides for the stock particles to orient their fibers in a radial sense. This alignment is facilitated by the rolling pressures induced on the particles by the shallow, widely spaced, distributor bars 35. Keep in mind the bars 35 are only slightly emergent from the base portions of the sections 32 on the relatively rotating discs. This rolling pressure, which increases as fibrous particles move through the entrance section of the refining throat, causes the particles to assume the form of cylindrical bundles of fibers. Due to the uniformly shallow nature of the bars 35, there is practically no cutting of the fibers such as normally occurs in the case of conventional refining plates.

From the entrance portion of the throat, the bundles of fibers flow to the intermediate refining portion which is defined by sections 34 of the opposed refiner plates 25. The slopes of the opposed sections 34 which are defined by the narrow bars 38 produce a relatively smooth continuation of the entrance portion of the throat, though having a lesser angle therebetween. As the bundles of fibers pass through the more restrictive and gradually decreasing cross-sectional area of the intermediate throat section, they are subjected to much greater rolling pressures as the closely spaced bars 38 pass in opposite directions. This causes fibers to be loosened from their respective bundles.

The exit portion of throat 42 which is defined by opposed refining sections 33 of the plates 25, is even more restrictively convergent. In flow of stock therethrough, the closely spaced bars 38, which have a slightly and gradually increasing depth from the sections 32 to the plate extremities 31, approach a parallel relation and produce a final compression on and rolling of the fibrous particles. This latter action puts a degree of compression on each particle that the fibers thereof physically separate on relief of the compressive force as they flow outwardly from the plates 25.

In the whole refining process, the invention apparatus is so designed to minimize the possibility of cutting the individual fibers. Accordingly, the product consists of stock having an optimum fiber content and quality.

In operation of the disc refiner as described, the form and cooperation of the refiner plates produces a compressive rolling action on fibrous stock to enable a high quality fiber product and a refiner operation at a constant and uniform feed rate and motor load. The fact that a rolling rather than a cutting action is enabled by the selected contouring of the refiner plates is an obvious factor in the quality of stock produced thereby as well as the minimal wear occasioned to refiner parts in refiner operation.

The invention plates are so designed to enable their application in a minimal size and to produce an optimal performance. By positioning the refiner bars primarily on the outer peripheral portion of the refiner plates, a greater concentration of work may be effected in a manner which precludes the necessity for an extended operating surface.

From the above description it will be apparent that there is thus provided a device of the character described possessing the particular features of advantage before enumerated as desirable, but which obviously is susceptible of modification in its form, proportions, detail construction and arrangement of parts without departing from the principle involved or sacrificing any of its advantages.

While in order to comply with the statute the invention has been described in language more or less specific as to structural features, it is to be understood that the invention is not limited to the specific features shown, but that the means and construction herein disclosed comprise but one of several modes of putting the invention into effect, and the invention is therefore claimed in any of its forms or modifications within the legitimate and valid scope of the appended claims.

Having thus described my invention, I claim:

1. A refiner plate having means defining an operating surface, said operating surface including a uniformly sloped entrance section which extends substantially one-half its operative length, a limited exit section sloped to provide a substantially flattened portion at its extremity and an intermediate section providing a continuing slope between said entrance and exit sections, said entrance section having a surface relatively unbroken save for widely spaced bars which are only slightly emergent therefrom.

2. A refiner plate having means defining an operating surface, said operating surface consisting of an entrance section, an exit section and an intermediate section therebetween, said sections being formed to merge in a continuous relatively flat slope, said entrance section having a relatively smooth surface and including a series of relatively wide shallow distributor bars thereon which are widely spaced and said exit and intermediate sections including relatively narrow refiner bars which are relatively closely spaced and define feed channels therebetween.

3. A refiner plate having an operating surface thereon, said operating surface including an entrance section, an exit section and an intermediate section therebetween, said entrance section having a smooth gradual slope and, emergent therefrom, relatively shallow widely spaced substantially rectangular projections forming distributor bars having a generally uniform depth from end to end, said intermediate and exit sections having slopes defined by relatively narrow refiner bars which smoothly merge with each other and the slope of said distributor bars.

4. A pulp refiner unit including opposed relatively rotatable discs, means defining a refining surface at each of the relatively adjacent faces of said discs, said refining surfaces being continuously sloped in a radial sense to form a refining throat therebetween which is widely divergent to its entrance end at the inner extremities of the refining surfaces and gradually decreased in cross-section to its exit end at the outer extremities of the refining surfaces, said refining surfaces having means flatly projected therefrom to exert a rolling influence on materials passed therebetween to initially orient such material in a radial sense and cause it to assume the form of cylindrical particles, said refining surfaces having means projected therefrom to their exit ends formed to compress the particles

to a degree the elements thereof physically separate on flow of the particles thereby.

5. A pulp refiner comprising means defining a flow path for fibrous particles to provide a convergent entrance section, a convergent exit section of less angularity than said entrance section and a connecting convergent section of intermediate angularity, said means including relatively moving elements at said entrance section which roll the particles to orient the fibers thereof in a sense longitudinally of the flow path and means in said intermediate and exit sections to relatively move and exert a rolling influence on the fibers which flow thereby while applying a gradually increasing compressive force thereon to a degree that the fiber elements of such particles will physically separate on release of the compression.

6. A pulp refiner unit, including opposed plate elements having inner and outer ends, each inner end having a surface sloping toward the outer end and each outer end having a surface sloping less sharply than the first said surface toward the outer extremity, with an intermediate portion of the plate having a connecting sloping surface, opposing plate elements so defining a passageway therebetween extending from the inner ends to the outer ends which is progressively restricted in each of three stages, the rate of increase in restriction being less in each successive stage, and means on the surfaces of said plates for exerting a rolling influence on material passing through said passageway, which motion is accompanied by a gradually increasing applied compression of the materials due to said progressive restriction.

7. A pulp refiner unit according to claim 6, characterized in that the first said surface occupies a part of the overall surface of the plate element greater than the part occupied by either of the other surfaces.

References Cited by the Examiner

UNITED STATES PATENTS

1,477,013	12/1923	Snyder	241—296
1,744,226	1/1930	Hussey	241—251
3,040,996	6/1962	Ginaven	241—296 X
3,040,997	6/1962	Borden	241—260

ROBERT C. RIORDON, *Primary Examiner.*

45 J. SPENCER OVERHOLSER, *Examiner.*