

Jan. 7, 1958

F. W. BROWN ET AL
ELECTRICALLY SCORING TARGET

2,819,084

Filed April 19, 1955

FIG. 1

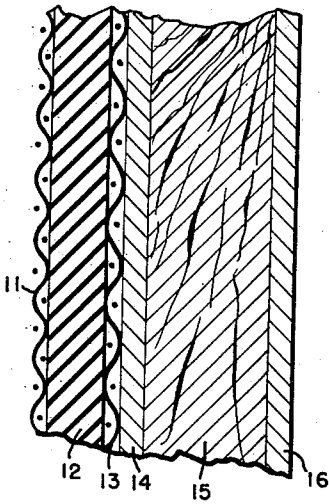

FIG. 2

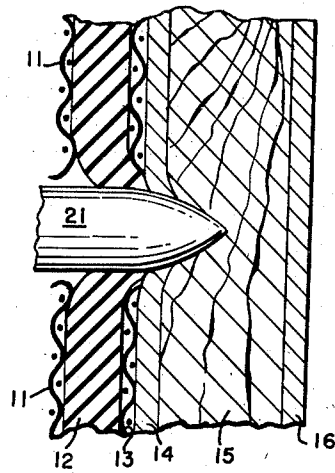
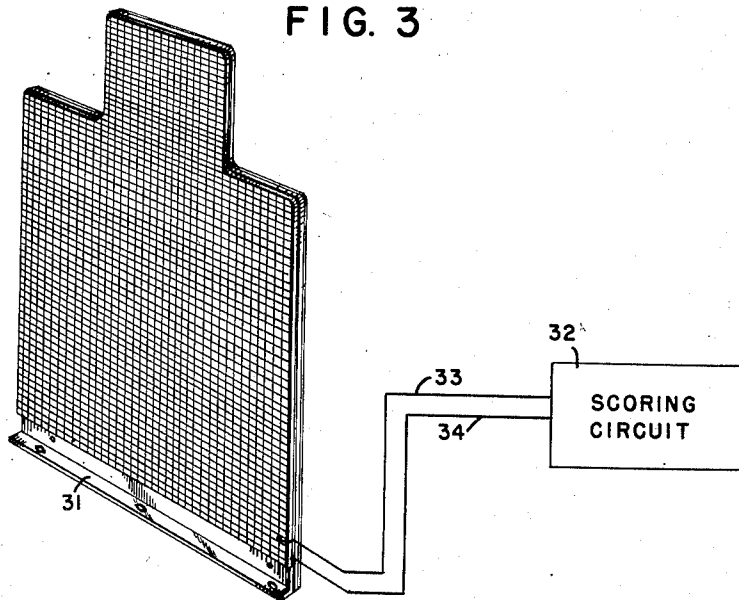

FIG. 3



INVENTORS.
FORREST W. BROWN
KENNETH J. CHICHESTER
BY

Ernie B. Steinberg
AGENT.

1

2,819,084

ELECTRICALLY SCORING TARGET

Forrest W. Brown, New Canaan, and Kenneth J. Chichester, Stamford, Conn., assignors to The Reflectone Corporation, Stamford, Conn., a corporation of Connecticut

Application April 19, 1955, Serial No. 502,447

6 Claims. (Cl. 273—102.2)

This invention relates to targets and more particularly to electrically scoring targets for use in practice with rifles and machine guns.

One of the objects of this invention is the provision of a target which is capable of being punctured by bullets a large number of times without substantial damage so that the target has an exceptionally long life.

Another object of this invention is to provide a target so constructed and arranged as to eliminate the hazard of deflected or ricocheting bullets.

Another object of this invention is to provide an electrically scoring target which is not affected by humidity, rain and other influences of the weather.

A further object of this invention is the provision of a target which provides instantaneous indication of a hit at a remote location.

A further and other object of this invention is the provision of a target in which hit detection is achieved with utmost reliability and by the use of simple electrical circuit means.

A still further object of this invention is to provide a target which is insensitive to and does not score upon gun blast only.

Another and further object of the invention is the provision of a target characterized by light weight yet stable when standing erect and supported only at its base.

Still another object of the invention is the provision of a target which does not score erroneously due to earth or stones sprayed into the target caused by hits on the ground near the target.

One feature of the invention includes an electrically scoring target of laminated construction which comprises a flexible, resilient rubber diaphragm. One side of the diaphragm is in contact with a flexible layer of electrically conductive material. The other side of said diaphragm is in contact with one side of the layer of electrically insulating material. Another layer of electrically conductive material is in contact with the other side of said layer of insulating material.

For a better understanding of the present invention together with other and further objects thereof reference is made to the following description taken in connection with the accompanying drawings in which:

Figure 1 is a cross sectional view of the target construction;

Figure 2 is a sectional view of the target and showing a bullet partially penetrated through the target construction; and

Figure 3 is a front view, partly in perspective, of the target with the electrical scoring circuit connected to it.

Referring now to the figures, numeral 12 identifies a layer of electrically conductive rubber hereinafter referred to as a diaphragm. Such rubber may be obtained in sheeting from the United States Rubber Co., New York, N. Y., as Compound M-8737, having a thickness of 1/16 inch. The front surface of the rubber diaphragm is in contact with a metallic screen 11, such as copper or bronze screening commonly employed for

2

screen windows. On the rear side of the rubber diaphragm there is disposed and bonded thereto a layer of electrically insulating material 13, preferably a plastic mesh, such as window type screening available commercially under the trade-name of "Saran" screening. A thin layer of electrically conductive material, such as a thin sheet of aluminum or copper 14 is bonded to the other side of the screening material 13. Layers 15 and 16 serve to impart mechanical strength to the target construction and their particular construction is not of great significance, although in order to obtain light weight and to assure that a bullet will not lodge itself within the target structure certain properties are necessary. Consequently, layers 15 and 16 should be of light weight, low resistance to penetration by a bullet, high mechanical rigidity, and last but not least, substantially unaffected by climatic and environmental conditions. Excellent results have been obtained by constructing layer 15 of balsa wood or of foamed plastic material, particularly foamed cellulose-acetate or foamed polystyrene, backed by a thin layer of copper or aluminum sheeting 16. Layers 11 to 16 are bonded to one another by using various commercially available cements, such as compound EC-870 manufactured by the Minnesota Mining & Manufacturing Co., Adhesive and Coatings Division, Detroit, Michigan.

Rubber diaphragm 12 is resilient so that it tends to reseal itself after a bullet has passed through. This self-sealing action takes place primarily due to the adhesive action between the particles of rubber and due to the resiliency of rubber in stretching to let the bullet pass through. The metallic screen 11 and the insulating screen 13 are bonded to the rubber diaphragm but since both screens are flexible, they tend to yield and stretch in unison with the rubber diaphragm 12 thereby keeping the damage to the target upon penetration of a bullet to a minimum.

The metallic screen 11 in front of the target is provided in order to lower the electrical resistivity of the rubber. If connection to the conductive rubber is established near the bottom of the target, as indicated in Figure 3, and a hit is scored near the top of the target, a long electrical circuit path exists between the point of connection and the location of impact of the bullet. This high resistive path is subject to large variations due to the influences of humidity, rain, mechanical configuration, etc. In order to lower the resistance of the conductive rubber, the electrically conductive screen 11 is cemented upon the surface of the rubber diaphragm 12 thereby establishing electrical connection to the rubber over a very much larger area, thus maintaining the electrical resistance within well defined and low limits, regardless of distance between bullet impact and circuit connection to diaphragm. Whereas the linear resistance of such a conductive rubber diaphragm measured by spacing two electrodes approximately one inch apart is in the order of several thousand of ohms and may assume values of several megohms, by virtue of the construction described heretofore this very same resistance is lowered to values of 10 to 100 ohms.

The operation of the target can be visualized by reference to Figure 2. Upon impact and penetration of bullet 21 into the target construction, the metallic jacket of the bullet establishes connection between the metallic screen 11, rubber diaphragm 12 and the metallic electrode 14 of the target. After a few hits have been scored within this area, some screening may be missing but the target is still operative because the rubber diaphragm 12 bends in the direction of penetration of the bullet and thereby establishes temporary connection with the metallic layer 14 as shown in Figure 2. Since the rubber diaphragm 12 has been transformed to a low resistance electrode, sensing of the short circuit between layers 12 and 14 is

accomplished by simple electrical means well known to those skilled in the art. After the bullet has passed through the target, rubber diaphragm 12 tries to restore itself to its original shape. By virtue of this flexible construction it has been possible to score in excess of ten hits per ten rounds of 0.30 caliber fired into an area of one square inch.

Figure 3 shows a typical target mounted on a base 31 and connected to a remote scoring indicator 32 via conductor 33 which is connected to screen 11 and via conductor 34 which is connected to electrode 14. The scoring circuit 32 by means of relays indicates whenever a short circuit is obtained between conductive rubber 12 or screen 11 respectively and the metallic sheet 14.

It will be apparent that this target is completely unaffected by mechanical vibration or by sound waves and only the direct connection between conductive rubber 12 and metallic layer 14 will indicate a hit. Since the rubber is elastic the target is "self-clearing" restoring itself instantly to the original condition without leaving extruded material extending in the direction of the bullet path. It has been found that by applying the cement which bonds the Saran screening 13 to the conductive rubber 12 and to the metallic layer 14 in such a manner that the interstices, that is, the open area of the screen, is substantially filled with cement, the insulating space between the two electrodes will not fill up with moisture or rain, thus obtaining a target construction which is unaffected by environmental conditions.

Good mechanical strength has been achieved by using foamed cellulose-acetate $\frac{3}{8}$ inch thick for the layer carrying numeral 15. This material is characterized by high structural strength, extremely low weight and imperviousness to water. Metallic layers 14 and 16 have been made from aluminum, soft to one quarter hard, and $\frac{1}{64}$ or $\frac{1}{32}$ inch thick. The softness of the metal appears significant since the extruded area caused by a bullet passing through decreases with the softness of the metallic material. As an example, a four square foot target constructed in accordance with the above directions successfully withstood 3000 rounds of 0.30 caliber shell.

Compound M-8737 of U. S. Rubber Company mentioned in the foregoing specification is a conductive rubber composition used for static electricity elimination. Its approximate mechanical characteristics are: Specific gravity 1.49; average tensile strength 2000 lbs./sq. inch; average elongation 175 percent; durometer reading 85 ± 5 . These specifications are included herein primarily for informational purposes and in no way are these data to be construed as limiting factors since it will be obvious to those skilled in the art that the flexible, resilient diaphragm can be made subject to wide variations without departing from the principle of the invention. Still further, it is apparent that such a diaphragm may be constructed from natural rubber, synthetic rubber, neoprene or other materials which exhibit characteristics similar to those described above.

While there have been described and illustrated specific embodiments of the invention, it will be obvious that various changes and modifications may be made therein without departing from the field of the invention which should be limited only by the scope of the appended claims.

What is claimed is:

1. An electrically scoring target of laminated construction which includes two spaced electrodes adapted to be momentarily short-circuited by a bullet passing there-through comprising; a first electrode which includes a flexible, resilient, electrically conductive, rubber diaphragm tending to reseal itself after a bullet has passed there-through; a flexible layer of metallic material in contact with one side of said diaphragm to produce an electrode of substantially low electrical resistance which tends to reseal itself by reducing the size of the bullet hole; a layer

of electrically conductive material constituting the second electrode spaced from said first electrode; and a layer of insulating material disposed between said electrodes to establish electrical insulation therebetween.

2. An electrically scoring target of laminated construction which includes two spaced electrodes adapted to be momentarily short-circuited by a bullet passing there-through comprising; a first electrode which includes a flexible, resilient, electrically conductive, rubber diaphragm tending to reseal itself after a bullet has passed there-through; a flexible layer of metallic material bonded to one side of said diaphragm to produce an electrode of substantially low electrical resistance which tends to reseal itself by reducing the size of the bullet hole; a layer of electrically conductive material constituting the second electrode spaced from said first electrode; a flexible layer of insulating material disposed between said electrodes to establish electrical insulation therebetween; and said layer of insulating material being bonded to both electrodes.

3. An electrically scoring target of laminated construction which includes two spaced electrodes adapted to be momentarily short-circuited by a bullet passing there-through comprising; a first electrode which includes a flexible, resilient, electrically conductive, rubber diaphragm tending to reseal itself after a bullet has passed there-through; a flexible layer of metallic mesh material bonded to one side of said diaphragm to produce together with said diaphragm an electrode of substantially low electrical resistance which tends to reseal itself by reducing the size of the bullet hole; a layer of electrically conductive material constituting the second electrode spaced from said first electrode; a layer of flexible mesh made of electrically insulating material disposed between said electrodes to establish electrical insulation therebetween; and said layer of insulating material being bonded to both electrodes.

4. An electrically scoring target of laminated construction which includes two spaced electrodes adapted to be momentarily short-circuited by a bullet passing there-through comprising; a first electrode which includes a flexible, resilient, electrically conductive, rubber diaphragm tending to reseal itself after a bullet has passed there-through; a flexible layer of metallic mesh material bonded to one side of said diaphragm to lower the electrical resistance of said diaphragm thus producing an electrode of substantially low electrical resistance which tends to reseal itself by reducing the size of the bullet hole; a layer of electrically conductive material constituting the second electrode spaced from said first electrode; a layer of flexible mesh made of electrically insulating material disposed between said electrodes to establish electrical insulation therebetween; said layer of insulating material being bonded to both electrodes; and the interstices of said mesh of insulating material substantially filled with bonding material.

5. An electrically scoring target of laminated construction which includes two spaced electrodes adapted to be momentarily short-circuited by a bullet passing there-through comprising; a first electrode which includes a flexible, resilient, electrically conductive, rubber diaphragm tending to reseal itself after a bullet has passed there-through; a flexible layer of metallic mesh material bonded to the bullet entering side of said diaphragm to lower the electrical resistance of said diaphragm thus producing a unitary electrode of substantially low electrical resistance which tends to reseal itself by reducing the size of the bullet hole; a layer of electrically conductive material constituting the second electrode spaced rearward of said first electrode; a layer of flexible mesh made of electrically insulating material disposed between said electrodes to establish electrical insulation therebetween; said layer of insulating material being bonded to both electrodes; and the interstices of said mesh of insulating material substantially filled with bonding material.

6. An electrically scoring target of laminated construc-

5

tion which includes two spaced electrodes adapted to be momentarily short-circuited by a bullet passing there-through comprising; a first electrode which includes a flexible, resilient, electrically conductive, rubber diaphragm tending to reseal itself after a bullet has passed there-through; a flexible layer of metallic mesh material bonded to the bullet entering side of said diaphragm to lower the electrical resistance of said diaphragm thus producing an electrode of substantially low electrical resistance which tends to reseal itself by reducing the size of the bullet hole; a layer of electrically conductive material constituting the second electrode spaced rearward of said first electrode; a layer of flexible mesh made of electrically insulating material disposed between said electrodes to establish electrical insulation therebetween; said layer of insulating material being bonded to both electrodes; the

5

interstices of said mesh of insulating material substantially filled with bonding material; said second electrode backed by mechanical supporting means to impart strength to said laminated target construction to render the target substantially rigid for standing erect; and a source of electrical potential connected to said electrodes.

6

References Cited in the file of this patent

UNITED STATES PATENTS

10	2,341,360	Bulgin -----	Feb. 8, 1944
	2,501,218	Hill -----	Mar. 21, 1950
	2,535,280	Gartrell -----	Dec. 26, 1950
	2,576,960	McAvoy -----	Dec. 4, 1951
15	2,693,959	Ross -----	Nov. 9, 1954