



INTERNATIONAL APPLICATION PUBLISHED UNDER THE PATENT COOPERATION TREATY (PCT)

<p>(51) International Patent Classification <sup>6</sup> : C12N 15/12, 15/62, 15/85, 15/86, 5/10, C07K 14/435, C12Q 1/02, 1/68, G01N 33/50, 33/52</p>	<p>A1</p>	<p>(11) International Publication Number: <b>WO 97/26333</b> (43) International Publication Date: 24 July 1997 (24.07.97)</p>
<p>(21) International Application Number: PCT/US97/00755 (22) International Filing Date: 17 January 1997 (17.01.97) (30) Priority Data: 08/588,201 18 January 1996 (18.01.96) US (60) Parent Application or Grant (63) Related by Continuation US 08/588,201 (CIP) Filed on 18 January 1996 (18.01.96) (71) Applicant (for all designated States except US): UNIVERSITY OF FLORIDA RESEARCH FOUNDATION, INCORPORATED [US/US]; 223 Grinter Hall, Gainesville, FL 32611 (US). (72) Inventors; and (75) Inventors/Applicants (for US only): ZOLOTUKHIN, Sergei [UA/US]; 3611-59 S.W. 36th Street, Gainesville, FL 32608 (US). MUZYCZKA, Nicholas [US/US]; 9837 S.W. 67th Drive, Gainesville, FL 32608 (US). HAUSWIRTH, William, W. [US/US]; 12001 S.W. 39th Street, Gainesville, FL 32608 (US).</p>	<p>(74) Agent: KITCHELL, Barbara, S.; Arnold, White &amp; Durkee, P.O. Box 4433, Houston, TX 77210 (US). (81) Designated States: AL, AM, AT, AU, AZ, BA, BB, BG, BR, BY, CA, CH, CN, CU, CZ, DE, DK, EE, ES, FI, GB, GE, HU, IL, IS, JP, KE, KG, KP, KR, KZ, LC, LK, LR, LS, LT, LU, LV, MD, MG, MK, MN, MW, MX, NO, NZ, PL, PT, RO, RU, SD, SE, SG, SI, SK, TJ, TM, TR, TT, UA, UG, US, UZ, VN, ARIPO patent (KE, LS, MW, SD, SZ, UG), Eurasian patent (AM, AZ, BY, KG, KZ, MD, RU, TJ, TM), European patent (AT, BE, CH, DE, DK, ES, FI, FR, GB, GR, IE, IT, LU, MC, NL, PT, SE), OAPI patent (BF, BJ, CF, CG, CI, CM, GA, GN, ML, MR, NE, SN, TD, TG).  Published With international search report.</p>	

(54) Title: HUMANIZED GREEN FLUORESCENT PROTEIN GENES AND METHODS

(57) Abstract

Disclosed are synthetic and "humanized" versions of green fluorescent protein (GFP) genes adapted for high level expression in mammalian cells, especially those of human origin. Base substitutions are made in various codons in order to change the codon usage to one more appropriate for expression in mammalian cells. Recombinant vectors carrying such humanized genes are also disclosed. In addition, various methods for using the efficient expression of humanized GFP in mammalian cells and in animals are described.

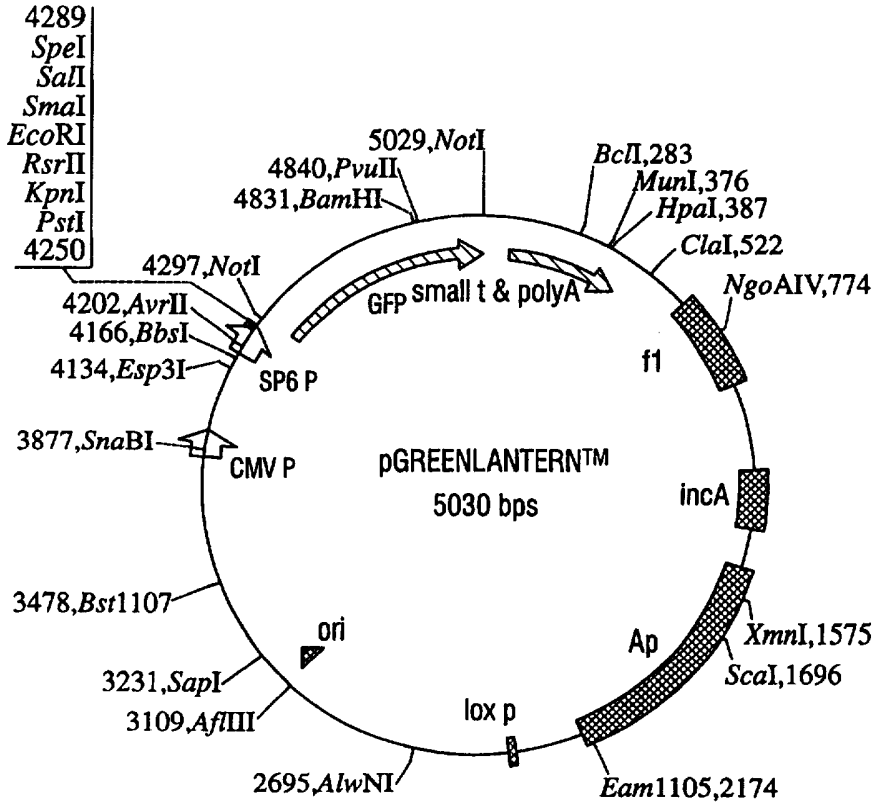

**FOR THE PURPOSES OF INFORMATION ONLY**

Codes used to identify States party to the PCT on the front pages of pamphlets publishing international applications under the PCT.

AM	Armenia	GB	United Kingdom	MW	Malawi
AT	Austria	GE	Georgia	MX	Mexico
AU	Australia	GN	Guinea	NE	Niger
BB	Barbados	GR	Greece	NL	Netherlands
BE	Belgium	HU	Hungary	NO	Norway
BF	Burkina Faso	IE	Ireland	NZ	New Zealand
BG	Bulgaria	IT	Italy	PL	Poland
BJ	Benin	JP	Japan	PT	Portugal
BR	Brazil	KE	Kenya	RO	Romania
BY	Belarus	KG	Kyrgyzstan	RU	Russian Federation
CA	Canada	KP	Democratic People's Republic of Korea	SD	Sudan
CF	Central African Republic	KR	Republic of Korea	SE	Sweden
CG	Congo	KZ	Kazakhstan	SG	Singapore
CH	Switzerland	LI	Liechtenstein	SI	Slovenia
CI	Côte d'Ivoire	LK	Sri Lanka	SK	Slovakia
CM	Cameroon	LR	Liberia	SN	Senegal
CN	China	LT	Lithuania	SZ	Swaziland
CS	Czechoslovakia	LU	Luxembourg	TD	Chad
CZ	Czech Republic	LV	Latvia	TG	Togo
DE	Germany	MC	Monaco	TJ	Tajikistan
DK	Denmark	MD	Republic of Moldova	TT	Trinidad and Tobago
EE	Estonia	MG	Madagascar	UA	Ukraine
ES	Spain	ML	Mali	UG	Uganda
FI	Finland	MN	Mongolia	US	United States of America
FR	France	MR	Mauritania	UZ	Uzbekistan
GA	Gabon			VN	Viet Nam

## DESCRIPTION

### HUMANIZED GREEN FLUORESCENT PROTEIN GENES AND METHODS

#### BACKGROUND OF THE INVENTION

##### **1. Field of the Invention**

5           The present invention relates generally to the field of reporter genes and particularly provides improved green fluorescent protein (GFP) genes, constructs and methods of use. The *gfp* genes disclosed herein are humanized *gfp* genes adapted for expression in mammalian and human cells by using preferred DNA codons.

##### **2. Description of the Related Art**

10           Reporter molecules are frequently used in biological systems to monitor gene expression. Commonly used reporter genes include  $\beta$ -galactosidase, firefly luciferase, alkaline phosphatase, chloramphenicol acetyltransferase (CAT) and  $\beta$ -glucuronidase (GUS). However, the available reporter genes have certain drawbacks that limit their use. A frequently encountered limitation is that the introduction of a substrate is  
15           required. Other drawbacks include, for example, the size of certain proteins which means that expression of reporter-fusion proteins can be difficult.

          Another useful strategy is to label a protein with a fluorescent tag to enable subsequent detection and localization in intact cells. Fluorescent labeling is used in conjunction with immunofluorescence and fluorescence analog cytochemistry, in  
20           which the biochemistry and trafficking of proteins are monitored after microinjection into living cells.

          Fluorescence labeling has generally been achieved by purifying proteins and covalently conjugating them to reactive derivatives of organic fluorophores. In these methods, the stoichiometry and locations of dye attachment are often difficult to  
25           control and careful repurification of the proteins is usually necessary. A further

problem is introducing the labeled proteins into a cell, which often involve microinjection techniques or methods of reversible permeabilization to introduce the proteins through the plasma membrane.

A molecular biological alternative to fluorescent-tagged proteins has been made possible by recent advances and the cloning of green fluorescent protein (GFP). The green fluorescent protein (GFP) encoded by the *gfp10* gene from the jellyfish *Aequorea victoria* is a protein of 238 amino acids which absorbs blue light (major peak at 395 nm) and emits green light (major peak at 509 nm) (Morin and Hastings, 1971; Ward *et al.*, 1980; Prasher *et al.*, 1992). The GFP hexapeptide chromophore starts at amino acid 64 and is derived from the primary amino acid sequence through the cyclization of serine-dehydrotyrosine-glycine within this hexapeptide (Shimomura, 1979; Cody *et al.*, 1993).

The light-stimulated GFP fluorescence is species-independent and does not require any cofactors, substrates, or additional gene products from *A. victoria* (Chalfie *et al.*, 1994). This allows GFP detection in living cells other than *A. victoria* so long as meaningful gene expression can be achieved. The small size of *gfp10* and the "real-time" detection of the product thus makes GFP a promising candidate for use as a reporter gene.

Certain GFP variants have recently been reported that have improved spectral properties. For example, Heim *et al.* (1994) described a mutant that fluoresces blue and contains a histidine in place of Tyr66. Heim *et al.* (1995) later described a Ser65→Thr GFP mutant that has a spectrum much closer to that of *Renilla reniformis*, which has an extinction coefficient per monomer more than 10 times that of the longer-wavelength peak of *Aequorea* GFP.

However, despite certain developments, such as the variants described above, the present usefulness of GFP is still limited by variable and, at best, low expression levels in mammalian cells. Therefore, it is evident that new developments in GFP technology are needed before the full potential of this protein can be realized,

particularly in applications that require expression in mammalian cells, including gene therapy strategies.

### SUMMARY OF THE INVENTION

5 The present invention seeks to overcome these and other drawbacks inherent in the prior art by providing humanized green fluorescent protein (GFP) genes adapted for expression in mammalian and human cells. The humanized *gfp* genes of the invention are prepared by incorporating codons preferred for use in human genes into the DNA sequence. Also provided are humanized *gfp* expression constructs and various methods of using the humanized genes and vectors.

10 Accordingly, the present invention provides humanized green fluorescent protein (GFP) genes and methods of making and using such genes. As used herein the term a "humanized green fluorescent protein (GFP) gene" means a gene that has been adapted for expression in mammalian and human cells by replacing at least one, and preferably, more than one, and most preferably, a significant number, of jellyfish *gfp* 15 codons with one or more codons that are more frequently used in human genes.

The humanized genes of the invention are preferably cDNAs, although genomic copies are by no means excluded. The humanized genes are also preferably humanized versions adapted from the *A. victoria gfp* gene, although other *gfp* gene sources are, again, not excluded.

20 In certain embodiments, the present invention provides humanized *gfp* genes that encode a green fluorescent protein that has the amino acid sequence of SEQ ID NO:2.

In other embodiments, humanized *gfp* genes will encode GFP variants that are generally based upon the foregoing sequence, but that have certain changes. A 25 particular example is a humanized gene that encodes a GFP with an amino acid sequence of SEQ ID NO:2 in which Serine at position 65 has been replaced by Threonine.

A further example is a humanized *gfp* gene that encodes a green fluorescent protein that has the amino acid sequence of SEQ ID NO:2 in which Tyrosine at position 66 has been replaced by Histidine.

Another example is a humanized *gfp* gene that encodes a GFP that has the amino acid sequence of SEQ ID NO:2 in which the chromophore sequence Phe Ser Tyr Gly Val Gln (SEQ ID NO:4) between positions 64 and 69 has been replaced by the sequence Met Gly Tyr Gly Val Leu (SEQ ID NO:5).

Structural equivalents of the humanized *gfp* genes are also included within the present invention. However, mutants that are truncated by more than one amino acid residue at the amino terminus or more than about 10 or 15 amino acid residues from the carboxyl terminus are not generally considered to be useful in the context of producing a fluorescent protein. The encoded GFP should therefore be a minimum of about 222 amino acids in length, with proteins of about 238 amino acids in length generally being preferred.

The humanized genes of the present invention are also definable by genes in which at least about 10% of said codon positions contain a humanized codon. That is, they contain a codon that is preferentially used in human genes in place of a codon that is not so frequently used in human genes.

In other embodiments, the humanized genes will have at least about 15%, about 20%, about 25%, about 30% or about 35% of the codon positions defined by the presence of a humanized codon.

Humanized *gfp* genes wherein at least about 50% or above of the codon positions contain a humanized codon are also contemplated.

Preferred humanized *gfp* genes of the invention are those genes that contain certain key changes. Examples are genes that comprises at least seven humanized codons from the 10 codons located at codon positions 18, 53, 93, 125, 150, 178, 195, 208, 236 and 224 of the jellyfish *gfp* sequence.

Preferably, humanized *gfp* genes will comprise at least eight, at least nine, or ten, humanized codons from the 10 codons located at codon positions 18, 53, 93, 125, 150, 178, 195, 208, 236 and 224 of the jellyfish *gfp* gene sequence.

Such constructs are exemplified by humanized genes that comprise any one of  
5 the humanized Leucine codons CTG, CTC or TTG at codon positions 18, 53, 125, 178, 195 and 236 of the GFP gene sequence. A further example is a humanized *gfp* gene that comprises the humanized Valine codon GTG at codon positions 93, 150 and 224 of the GFP gene sequence. Other examples are humanized genes that comprise the humanized Serine codon TCT at codon position 208 of the GFP gene sequence.

10 The humanized *gfp* genes encompassed by this invention also include those genes that comprises an increased number of GCC or GCT Alanine-encoding codons in comparison to the wild type jellyfish gene sequence of SEQ ID NO:1.

By the phrase "increased number of codons in comparison to the wild type jellyfish gene sequence of SEQ ID NO:1" is meant that the humanized sequence  
15 contain an increased number of codons encoding a particular amino acid within the GFP coding region that encodes the amino acid sequence of SEQ ID NO:2, or one of the mutants or other equivalents described herein, in comparison to those codons encoding the same amino acid that are present within the coding region of the wild type jellyfish gene sequence of SEQ ID NO:1. Thus it will be understood that the  
20 term "increased", when used in this context, does not mean the addition of one or more codons to a terminal portion of the coding region, but rather means replacement of an unfavorable codon within the coding region with a codon that is more favorable for translation in a human or mammalian cell.

In light of the definition set forth above, the humanized *gfp* genes of the  
25 invention may also be defined as those genes that comprise an increased number of TGC Cysteine-encoding codons; an increased number of GAC Aspartate-encoding codons; an increased number of GAG Glutamate-encoding codons; an increased number of TTC Phenylalanine-encoding codons; an increased number of GGC

Glycine-encoding codons; an increased number of CAC Histidine-encoding codons; an increased number of ATC Isoleucine-encoding codons; an increased number of AAG Lysine-encoding codons; an increased number of CTG or CTC Leucine-encoding codons; an increased number of AAC Asparagine-encoding codons; an increased number of CCC or CCT Proline-encoding codons; an increased number of CAG Glutamine-encoding codons; an increased number of CGC, AGG or CGG Arginine-encoding codons; an increased number of AGC or TCC Serine-encoding codons; an increased number of ACC Threonine-encoding codons; an increased number of GTG or GTC Valine-encoding codons; and/or an increased number of TAC Tyrosine-encoding codons in comparison to the wild type jellyfish gene sequence of SEQ ID NO:1.

In certain embodiments, the humanized *gfp* genes may also comprise a TGA termination codon.

Humanized *gfp* genes may also be defined by comprising a decreased number of certain codons in comparison to the wild type jellyfish gene sequence of SEQ ID NO:1. "Decreased" in this context also means that the humanized sequence contain a decreased number of codons encoding a particular amino acid within the GFP coding region that encodes the amino acid sequence of SEQ ID NO:2, or a mutant or equivalent thereof, in comparison to those codons encoding the same amino acid that are present within the coding region of the wild type jellyfish gene sequence of SEQ ID NO:1. Thus it will be understood that "decreased" does not in any way reflect the simple deletion of codons from any portion of the coding region, but again refers to replacement of a jellyfish codon with a codon that occurs more frequently in human genes.

Accordingly, humanized *gfp* genes of the present invention are also be defined as those genes that comprise a decreased number of GCA Alanine-encoding codons; a decreased number of GGU Glycine-encoding codons; a decreased number of CTT, CTA or TTA Leucine-encoding codons; a decreased number of AGA Arginine-



encoding codons; a decreased number of AGT, TCA or TCG Serine-encoding codons; or a decreased number of GTT or GTA Valine-encoding codons.

Although not believed to be required, it is currently preferred that the humanized *gfp* genes should include a Kozak consensus sequence operatively positioned upstream from the humanized gene sequence (i.e., the gene is positioned downstream from the Kozak consensus sequence).

Certain preferred humanized *gfp* genes will comprise the nucleic acid sequence of SEQ ID NO:3. However, this is by no means limiting and is just one exemplary embodiment of the present invention. Detailed directions as how to make and use many other such humanized *gfp* genes are included herein. For example, one may refer to the information in Table 2, Table 3 and Table 4 in creating any one of a number of suitable humanized *gfp* genes.

Genes humanized in the manner of the invention may also be operatively linked to other protein-encoding nucleic acid sequences. This will generally result in the production of a fusion protein following expression of such a nucleic acid construct. Both N-terminal and C-terminal fusion proteins are contemplated.

Virtually any protein- or peptide-encoding DNA sequence, or combinations thereof, may be fused to a humanized *gfp* sequence in order to encode a fusion protein. This includes DNA sequences that encode targeting peptides, therapeutic proteins, proteins for recombinant expression, proteins to which one or more targeting peptides is attached, protein subunits and the like.

Recombinant vectors and plasmids form another important aspect of the present invention. In such vectors, the humanized *gfp* gene is positioned under the transcriptional control of a promoter, generally a promoter operative in a mammalian or human cell. "Positioned under the transcriptional control of" means that the humanized *gfp* sequence is positioned downstream from and under the transcriptional control of the promoter such the promoter is capable of directing expression of the

encoded GFP protein in a mammalian or human host cell upon introduction of the vector into such a cell.

The recombinant vectors of the invention will thus generally comprise a humanized *gfp* reporter gene operatively positioned downstream from a promoter, wherein the promoter is capable of directing expression of the humanized GFP gene in a mammalian or human cell. Preferably the promoter will direct expression of GFP in an amount sufficient to allow GFP detection by detecting the green fluorescence following expression of GFP in the cell. Such promoters are thus "operative" in mammalian and human cells.

Expression vectors and plasmids in accordance with the present invention may comprise one or more constitutive promoters, such as viral promoters or promoters from mammalian genes that are generally active in promoting transcription. Examples of constitutive viral promoters include the HSV, TK, RSV, SV40 and CMV promoters, of which the CMV promoter is a currently preferred example. Examples of constitutive mammalian promoters include various housekeeping gene promoters, as exemplified by the  $\beta$  actin promoter.

Inducible promoters and/or regulatory elements are also contemplated for use with the expression vectors of the invention. Examples of suitable inducible promoters include promoters from genes such as cytochrome P450 genes, heat shock protein genes, metallothionein genes, hormone-inducible genes, such as the estrogen gene promoter, and such like. Promoters that are activated in response to exposure to ionizing radiation, such as *fos*, *jun* and *egr-1*, are also contemplated. The tetVP16 promoter that is responsive to tetracycline is a currently preferred example.

Tissue-specific promoters and/or regulatory elements will be useful in certain embodiments. Examples of such promoters that may be used with the expression vectors of the invention include promoters from the liver fatty acid binding (FAB) protein gene, specific for colon epithelial cells; the insulin gene, specific for pancreatic cells; the transphyretin,  $\alpha$ 1-antitrypsin, plasminogen activator inhibitor

type 1 (PAI-1), apolipoprotein AI and LDL receptor genes, specific for liver cells; the myelin basic protein (MBP) gene, specific for oligodendrocytes; the glial fibrillary acidic protein (GFAP) gene, specific for glial cells; OPSIN, specific for targeting to the eye; and the neural-specific enolase (NSE) promoter that is specific for nerve  
5 cells.

The construction and use of expression vectors and plasmids is well known to those of skill in the art. Virtually any mammalian cell expression vector may thus be used connection with the humanized genes disclosed herein.

Preferred vectors and plasmids will be constructed with at least one multiple  
10 cloning site. In certain embodiments, the expression vector will comprise a multiple cloning site that is operatively positioned between a promoter and a humanized *gfp* gene sequence. Such vectors may be used, in addition to their uses in other embodiments, to create N-terminal fusion proteins by cloning a second protein-encoding DNA segment into the multiple cloning site so that it is contiguous and in-  
15 frame with the humanized *gfp* sequence.

In other embodiments, expression vectors may comprise a multiple cloning site that is operatively positioned downstream from the expressible humanized *gfp* gene sequence. These vectors are useful, in addition to their uses, in creating  
C-terminal fusion proteins by cloning a second protein-encoding DNA segment into  
20 the multiple cloning site so that it is contiguous and in-frame with the humanized *gfp* sequence.

Vectors and plasmids in which a second protein- or RNA-encoding nucleic acid segment is also present are, of course, also encompassed by the invention, irrespective of the nature of the nucleic acid segment itself.

25 A second reporter gene may be included within an expression vector of the present invention. The second reporter gene may be comprised within a second transcriptional unit. Suitable second reporter genes include those that confer

resistance to agents such as neomycin, hygromycin, puromycin, zeocin, mycophenolic acid, histidinol and methotrexate.

Expression vectors may also contain other nucleic acid sequences, such as IRES elements, polyadenylation signals, splice donor/splice acceptor signals, and the  
5 like.

Particular examples of suitable expression vectors are those adapted for expression using a recombinant adenoviral, recombinant adeno-associated viral (AAV) or recombinant retroviral system. Vaccinia virus, herpes simplex virus, cytomegalovirus, and defective hepatitis B viruses, amongst others, may also be used.

10 In certain embodiments, the expression vector or plasmid may comprise a humanized GFP reporter gene that has the nucleic acid sequence of SEQ ID NO:3.

Reporter gene expression kits are also provided, which kits generally comprise, in suitable container means, at least one expression vector or plasmid that comprises a humanized GFP gene. The vector or plasmid will generally be one that is  
15 capable of expressing GFP in an amount sufficient to allow GFP detection by green fluorescence following expression in a mammalian or human cell.

Recombinant host cells form another aspect of the present invention. Such host cells will generally comprise at least one copy of a humanized GFP gene. Preferred cells for expression purposes will be mammalian and human cells.  
20 However, it will be understood that other cell types are not excluded from those of the invention. Accordingly, cells such as bacterial, yeast, fungal, insect, nematode and plant cells are also possible, although such cells are not preferred for expression purposes.

In certain embodiments, the recombinant host cells will preferably incorporate  
25 a humanized GFP gene in a manner effective to allow the cell to express, or to be stimulated to express, GFP, most preferably, in an amount sufficient to allow GFP detection by its fluorescence. The recombinant host cell will thus preferably include a

humanized GFP gene that was introduced into the cell by means of a recombinant vector.

In certain embodiments, the recombinant host cell will express the humanized GFP gene to produce the encoded GFP protein, preferably, in an amount sufficient to allow GFP detection by its fluorescence. It is contemplated that cells containing as few as about 20 copies of a humanized *gfp* gene will often express the GFP protein in an amount sufficient to allow GFP detection by green fluorescence. In certain embodiments, cells containing as few as about 10 copies, about 5 copies or even about 1 or 2 copies of a humanized *gfp* gene will also likely satisfy the desired expression criteria, especially where the humanized *gfp* gene is a mutant gene. In other embodiments, the recombinant host cells may be capable of expressing a humanized gene in order to produce detectable GFP protein within a time frame of about 10 hours, and preferably within about 8 hours, and most preferably within about 6 hours or even less.

Examples of suitable recombinant host cells include VERO cells, HeLa cells, cells of Chinese hamster ovary (CHO) cell lines, COS cells, such as COS-7, and W138, BHK, HepG2, 3T3, RIN, MDCK, A549, PC12, K562 and 293 cells.

Cells of primary cell lines that have been established after removing cells from a mammal and culturing the cells for a limited period of time are also included within the cells of the present invention. These cells may be engineered by the hand of man and returned to the same host animal from which they were originally recovered. Such cells that contain a humanized *gfp* gene fall within the scope of the invention, irrespective of their location.

Naturally, recombinant cells also include those cells that are located within the body of an animal or human subject, as may have been targeted by gene therapy. These cells include all those that comprise at least one copy of a humanized *gfp* gene or vector, irrespective of the manner in which gene was acquired, e.g., by transfection, infection and the like.

In certain particular embodiments, recombinant host cells that comprise a humanized GFP gene that comprises the nucleic acid sequence of SEQ ID NO:3 are contemplated.

5 Many methods of using humanized *gfp* genes are provided by the present invention. The method of labeling or tagging a mammalian or human cell by expressing at least one humanized GFP gene in the cell is central to each of the methods. The humanized *gfp* gene should preferably produce GFP in an amount sufficient to allow ready detection of GFP in the cell by detecting GFP fluorescence.

10 Methods of identifying a mammalian or human cell within a population of cells are also provided. Such methods generally first comprise expressing at least one humanized GFP gene in the cell in a manner effective to produce an amount of GFP sufficient to allow GFP detection by fluorescence. The cell is then admixed, or allowed to become naturally admixed, with a population of cells that do not express GFP, following which the cell is identified by means of identifying a GFP-fluorescent cell.  
15

The term "a GFP-fluorescent cell", as used herein, means that a cell expresses a humanized GFP gene in a manner effective to result in the production of the GFP product in an amount sufficient to allow subsequent detection of the cell by detecting green fluorescence from GFP in the cell.

20 The invention further provides methods for identifying a mammalian or human cell that contains an exogenous DNA segment, which methods generally first comprise introducing into a mammalian or human cell an expression vector comprising a humanized GFP gene operatively linked to an exogenous DNA segment. The cell is then preferably cultured under conditions and for a period of time effective  
25 to allow expression of the humanized *gfp* gene in order to produce an amount of GFP sufficient to allow GFP detection by green fluorescence. Subsequently identifying a cell that contains the exogenous DNA segment is then achieved by identifying a GFP-fluorescent cell.

These methods are suitable for identifying exogenous DNA segments that encode untranslated products, such as an antisense nucleic acid molecule, ribozyme or other RNA species, and also, for identifying exogenous DNA segments that encode translated products, such as selected proteins or peptides.

5 In certain such embodiments, the expression vector for use in such methods will comprise a first coding region defined as the humanized *gfp* gene that encodes GFP and will also comprise a second coding region that comprises the exogenous DNA segment. These vectors are generally known as vectors that comprises at least two transcriptional or translational units. Two transcriptional units will naturally  
10 include two promoters that direct expression of their respective downstream genes.

The methods of identifying mammalian or human cells that contain an exogenous DNA segment are also suitable for use with expression vectors that comprise a first coding region that encodes a fusion protein that comprises GFP operatively linked to a selected protein or peptide, with the vector expressing a fusion  
15 protein that comprises GFP operatively linked to the selected protein or peptide. These aspects of the invention are generally, although not necessarily exclusively, confined to the detection of exogenous DNA segments that encode translated products.

Fusion proteins that are expressed in such a manner may comprise GFP  
20 operatively linked to a peptide that comprises a sub-cellular localization signal, such as a nuclear targeting peptide or a mitochondrial targeting peptide. The fusion proteins may also comprise GFP operatively linked to both a selected protein and a peptide that comprises a sub-cellular localization signal.

Such identification methods may be carried out *in vitro* with a variety of aims  
25 in mind, as described below. These identification methods may also be carried out *in vivo*, wherein the cell is located within a mammal or human subject.

Two or more humanized *gfp* genes, each expressing a GFP protein with different spectral properties, may be detected in a cell in the manner described above.

GFP-fluorescent cells, whether expressing one, two or more humanized *gfp* genes, may be identified by a variety of methods, including microscopy and fluorescence activated cell sorting (FACS).

Further examples of methods of the invention are methods for determining the  
5 location of a selected protein within a mammalian or human cell. These methods generally comprise first introducing into a cell an expression vector comprising a contiguous DNA sequence comprising a humanized GFP gene operatively linked to a gene encoding said selected protein. The vector will generally express a fusion  
10 protein comprising GFP operatively linked to the selected protein, wherein the fusion protein is produced in amounts sufficient to allow cell detection by detecting the green fluorescence of GFP. One can then identify the location of the selected protein within the cell by identifying the location of the green fluorescence from GFP.

These methods are suitable for determining the location of selected proteins within cells wherein the location is known or believed to be dependent upon external  
15 stimuli, such as, e.g., heat, cold, salt, or the presence of various agonists such as hormones, cytokines, neurotransmitters and the like. These methods are also suitable for determining the location of selected proteins within cells wherein the location is known or believed to be dependent upon internal signals, such as are present during changes in the cell cycle, during cell aging and apoptosis and the like.

20 Still further examples of methods of the invention are methods for targeting a protein to a selected location within a mammalian or human cell. These methods generally comprise first introducing into the cell an expression vector comprising a DNA sequence comprising a DNA sequence element that encodes a targeting peptide operatively linked and contiguous with a DNA sequence element of a humanized GFP  
25 gene, which is also operatively linked and contiguous with a DNA sequence element that encodes a protein. Such vectors express a fusion protein comprising a targeting peptide operatively linked to GFP and to a protein, wherein the fusion protein is produced in the cell in an amount sufficient to allow cell detection by detecting the



GFP fluorescence. The protein is then targeted to a selected location within the cell and the location is confirmed by identifying the location of the green fluorescence.

Yet further examples of methods associated with this invention are methods for testing candidate promoters in mammalian or human cells.

5           These methods generally comprises introducing into a cell an expression vector comprising a humanized GFP gene under the control of the candidate promoter and maintaining the cell under conditions effective and for a period of time sufficient to allow expression of the humanized GFP gene by the candidate promoter. "Conditions effective" and "periods of time sufficient" are defined as those conditions  
10           and times that would ordinarily result in GFP being produced in an amount sufficient to allow GFP detection by green fluorescence when using a known operative promoter.

          After maintaining the cell under the suitable conditions one would then identify any GFP-fluorescent cells, wherein the presence of GFP-fluorescent cells  
15           would be indicative of an active promoter in the expression construct within the identified cell.

          These methods are suitable for analyzing candidate tissue-specific promoters, where the promoter may be tested in a range of mammalian or human cells; and for analyzing candidate inducible promoters, where the promoter is generally tested under  
20           a range of conditions. As used herein, the term "tissue-specific promoter" is used to refer to promoters that direct gene expression exclusively in certain tissues and promoters that direct gene expression preferentially in given tissues, which may also be termed "tissue-preferential" promoters. The candidate promoter may also be a promoter naturally associated with a candidate gene that is being tested for expression  
25           in a mammalian or human cell.

          These methods are again suitable for analyzing promoters *in vitro* and *in vivo*, wherein in the latter case, the cell would be located within a mammal or human subject.

A further example of methods for using humanized *gfp* in the context of promoters are those methods for detecting substances that stimulate transcription from a selected promoter in a mammalian or human cell. Again, one generally introduces into a mammalian or human cell an expression vector comprising a humanized GFP  
5 gene under the control of a given promoter. One then exposes the cell to a composition suspected of containing a substance known or suspected to be capable of stimulating transcription from the given promoter. The cell is then cultured or maintained for a period of time that would ordinarily allow an active promoter to stimulate GFP-fusion protein production in an amount sufficient to allow cell  
10 detection by detecting the GFP-derived green fluorescence. The subsequent identification of a GFP-fluorescent cell is then indicative of the original presence of a substance that stimulates transcription from the given promoter.

These methods are also suitable for use *in vitro* and *in vivo*. *In vitro* uses allow substances such as toxins and pollutants to be detected by using appropriate  
15 promoters within the humanized *gfp* gene constructs.

As part of gene therapy, it is often necessary to determine gene expression levels in the treated mammalian animal or human subject. The present invention also provides methods for determining such the expression levels. These methods generally comprise expressing in cells of the animal an expression vector comprising  
20 a humanized GFP gene operatively linked to a selected gene. The expression vector will preferably be either a vector that expresses a GFP-fusion protein or a vector in which the humanized *gfp* gene and the selected protein gene each use the same or an equivalent promoter. The promoter will have preferably been shown to result in sufficient GFP expression to allow detection *in vitro*. One then determines the GFP-  
25 fluorescence in the cells of the animal, wherein the level of GFP-fluorescence is indicative of the expression level of the selected gene in the animal.

These methods can be adapted to provide methods for analyzing the expression of a selected gene in different tissues of a mammal or human subject. Such methods generally comprise introducing into the cells of the mammal an

expression vector comprising the selected gene under the control of the natural gene promoter, wherein the gene is operatively linked to a humanized GFP gene. The vector will preferably express a fusion protein that comprises the encoded gene product operatively linked to GFP, the fusion protein being produced in an amount  
5 sufficient to allow cell detection by detecting the green fluorescence of GFP. After maintaining the mammal under conditions effective and for a period of time sufficient to allow expression of the gene one then analyzes the cells of the tissues of the mammal to detect GFP-fluorescent cells, wherein the presence of GFP-fluorescent cells in a given tissue is indicative of gene expression in the tissue.

10 A further example in which the humanized *gfp* genes may be employed is in the recombinant production of GFP itself. Such methods of using a humanized GFP gene simply comprise expressing the humanized gene in a mammalian or human host cell and collecting the GFP expressed by said cell.

These methods may be more fully described as comprising the steps of:

- 15 (a) preparing a recombinant vector in which a humanized GFP gene is positioned under the control of a promoter operative in a mammalian or human cell;
- (b) introducing the recombinant vector into a mammalian or human host cell;
- 20 (c) culturing the host cell under conditions effective and for a period of time sufficient to allow expression of the encoded green fluorescent protein (GFP); and
- (d) collecting said expressed GFP and, preferably, purifying the GFP free from a significant amount of other cellular proteins.

25 Adaptations of such methods include those wherein the humanized GFP gene is fused to a DNA sequence encoding a protein or peptide of known molecular weight. Expression by the host cell thus results in a GFP fusion protein that may be used as a

-18-

fluorescent molecular weight marker. A range of such fluorescent molecular weight markers could be so-produced to produce a molecular weight determining kit.

### BRIEF DESCRIPTION OF THE DRAWINGS

The following drawings form part of the present specification and are included to further demonstrate certain aspects of the present invention. The invention may be better understood by reference to one or more of these drawings in combination with the detailed description of specific embodiments presented herein.

FIG. 1. Nucleotide sequence of the *gfp10* cDNA and the deduced amino acid sequence. Above each codon is the single letter designation for the amino acid. The mutations introduced in the *gfp<sub>h</sub>* sequence are shown below the substituted nucleotide of *gfp10*. The horizontal lines underline overlap regions of mutually priming oligonucleotides used to synthesize the *gfp<sub>h</sub>* cDNA. The sites of the restriction enzymes used to assemble extended pairs of oligonucleotides are shown in bold letters. The codons mutated to produce the Ser<sub>65</sub>Thr mutation, which produces higher fluorescence yield, and the Tyr<sub>66</sub>His mutation, which produces blue fluorescence, are shown in bold. In FIG. 1, the jellyfish *gfp10* nucleotide sequence is SEQ ID NO:1. The deduced amino acid sequence is SEQ ID NO:2. In SEQ ID NO:2, Xaa at position 65 may be Ser or Thr; and Xaa at position 66 may be Tyr or His. The exemplary humanized *gfp* sequence shown below the substituted nucleotide of *gfp10* in FIG. 1 is SEQ ID NO:3. In SEQ ID NO:3, the nucleotides at positions 193, 195 and 196 may be changed in order to encode either Ser or Thr; and either Tyr or His, as above.

FIG. 2A. Restriction maps of the AAV and Ad vector plasmids. Only those restriction sites relevant for the construction of the rAAV plasmids are shown. The sizes of removable elements and reporter gene cassettes are shown in base pairs. The genealogy of the genes and transcription elements is as follows: **TR** is the *Pst*I-*Bgl*II-fragment (145 bp + oligo (dG).oligo (dC), 160 bp total) from *dl3-94* (McLaughlin *et al.*, 1988); **P<sub>CMV</sub>** is the CMV immediate/early promoter/enhancer; **SD/SA** are the SV40 late viral protein gene 16s/19s splice donor and acceptor signals;

*gfp* is the *A. victoria* green fluorescent protein cDNA in pTR<sub>BS</sub>-UF, or the chemically synthesized humanized wt *gfp<sub>h</sub>* cDNA in pTR<sub>BS</sub>-UF1, or the Thr65 *gfp<sub>h</sub>* in pTR<sub>BS</sub>-UF2, or the His66 *gfp<sub>h</sub>* in pTR<sub>BS</sub>-UFB; **pA<sub>1</sub>** is the SV40 polyadenylation signal from the SV40 genome; **PO<sub>enh</sub>** is a tandem repeat of the enhancer from the polyoma virus mutant PYF441; **P<sub>TK</sub>** is the TK promoter of HSV; *neo'* is the neomycin resistance gene from Tn5; **pA<sub>2</sub>** is the bovine growth hormone polyadenylation signal from pRc/CMV (Invitrogen); **IRES** is the internal ribosomal entry site of Poliovirus type 1 from pSBC-1 (Dirks *et al.*, 1993).

FIG. 2B. Construction of pTR-UF general purpose vector.

10 FIG. 3. FACS analysis of 293 cells transfected with the pTR<sub>BS</sub>-UF series of recombinant plasmids. 293 cells (6-well dish) were transfected with a total of 2.8 µg of DNA, consisting of different ratios of *gfp*-containing plasmid and sonicated salmon sperm carrier DNA, using the conventional calcium phosphate transfection protocol. Cells were harvested 36 hrs posttransfection and analyzed on the flow cytometer.

15 Cells scored as positive were plotted on the graph as a function of the amount of *gfp*-carrying plasmid transfected. Clear bars correspond to the pTR<sub>BS</sub>-UF, shaded bars to the pTR<sub>BS</sub>-UF1, and black bars to the pTR<sub>BS</sub>-UF2.

FIG. 4A and FIG. 4B. Expression of rAAV-GFP<sub>H2</sub> in 293 cells. 293 cells were infected with CsCl-purified rAAV-GFP<sub>H2</sub> at an M.O.I. of 10. 36 hrs postinfection cells were photographed in a fluorescence microscope using a CHROMA Filter Cube #41014 GFP-HQ (excitation at 450±25 nm). FIG. 4A, cells under phase contrast, light field; FIG. 4B, same field, epifluorescence.

20

FIG. 5A, FIG. 5B, FIG. 5C and FIG. 5D. Fluorescence of G418-resistant clones containing rAAV-GFP<sub>H2</sub> provirus. 293 cells were infected with CsCl-purified rAAV-GFP<sub>H2</sub> at an M.O.I. of 1. 48 hrs postinfection cells were split and plated at a low (less than 10%) confluency. 18 hrs later G418 was added at a final concentration of 200 mg/ml. The media was changed every 4 days and G418 resistant colonies were photographed after 14 days of selection. FIG. 5A and FIG. 5C, G418-resistant

25

colonies under phase contrast, light field; FIG. 5B and FIG. 5D, same fields as in FIG. 5A and FIG. 5C, epifluorescence.

FIG. 6A, FIG. 6B, FIG. 6C and FIG. 6D. FACS analysis of 293 cells, stably transduced with rAAV-GFP<sub>J</sub>, rAAV-GFP<sub>H1</sub>, or rAAV-GFP<sub>H2</sub> and selected for 2 weeks with G418. FIG. 6A, the FACS histogram plot of the parental 293 cell line; FIG. 6B, 293 cells transduced with rAAV-GFP<sub>J</sub>; FIG. 6C, rAAV-GFP<sub>H1</sub>; and FIG. 6D, rAAV-GFP<sub>H2</sub>. In each case 20,000 cells were sorted. The uncorrected frequency of cells scored positive for each cell population was uninfected 293 cells: 0.05%; GFP<sub>J</sub>: 0.05%; GFP<sub>H1</sub>: 1.67%, GFP<sub>H2</sub>: 9.6 %.

FIG. 7. Fluorescence of the blue His66 mutant of the humanized *gfp*. 293 cells were co-transfected with pTR<sub>BS</sub>-UF2 and pTR<sub>BS</sub>-UFB and photographed 4 days posttransfection in the fluorescence microscope, using a Nikon Filter Cube V-2B.

FIG. 8. A single plaque of recombinant AdΔE1GFP as seen in the fluorescent microscope. The plaque was photographed at 40 hrs postinfection.

FIG. 9A, FIG. 9B, FIG. 9C and FIG. 9D. GFP fluorescence in a segment of guinea pig RPE infected with rAAV-GFP<sub>H2</sub>. FIG. 9A, differential interference contrast image of retina from an infected eye near the region shown on FIG. 9B. The darkly pigmented layer of cells near the top of the retina shown is the RPE layer in a slightly oblique section. The photoreceptor cell layer and other neuroretinal layers can be seen below the RPE. FIG. 9B, RPE layer from an rAAV-GFP<sub>H2</sub> inoculated eye near the injection site viewed under short wavelength excitation and fluorescein emission optics by confocal microscopy. FIG. 9C, fluorescence of the RPE layer from the same eye as in FIG. 9B at a site distal to the injection site. FIG. 9D, fluorescence of the RPE layer from the uninjected eye of the same animal as in FIG. 9A, FIG. 9B and FIG. 9C.

FIG. 10. pGREENLANTERN™ plasmid. GFP represents the humanized GFP of the present invention. Other functional elements and restriction sites are shown.

### **DETAILED DESCRIPTION OF THE PREFERRED EMBODIMENTS**

5           The jellyfish green fluorescent protein (GFP) has been proposed as a promising candidate for use as a reporter gene. However, a significant limitation of the *gfp* gene is that it does not result in adequate expression in mammalian cell systems. Indeed, the inventors' initial attempts to express the jellyfish GFP reporter gene delivered into human cell by a recombinant adeno-associated virus (AAV) were  
10           unsuccessful.

          The present inventors hypothesized that an important reason for the low expression of GFP was the poor translation efficiency of the mRNA in the human cell environment, which is characterized by a set of isoacceptor tRNAs that are different than those used in the jellyfish. In solving the expression problem, this invention thus  
15           provides synthetic versions of jellyfish green fluorescent protein (*gfp<sub>h</sub>*) cDNA that are adapted for high level expression in mammalian cells, especially those of human origin. According to this invention, base substitutions are made in *gfp* codons in order to change the codon usage within the *gfp10* coding sequence so that it is more appropriate for expression in mammalian cells. Also provided are expression  
20           plasmids, and a series of versatile recombinant AAV and Ad vectors for delivery and expression of genes in mammalian and human cells.

          In certain preferred aspects, the invention concerns a particular synthetic version of the *A. victoria* green fluorescent protein cDNA that is adapted for high level expression in mammalian and human cells. In this exemplary construct, a total  
25           of 92 base substitutions were made in 88 codons in order to change the codon usage within the *gfp10* coding sequence and dramatically improve expression in mammalian cells.

-22-

For fluorescence microscopy, the inventors increased the sensitivity of the GFP reporter gene system approximately 22 fold for one humanized construct and at least 45 fold for a second humanized construct. In FACS analyses with humanized gene constructs, one construct was at least 32-fold more detectable than the original jellyfish gene, and the other construct was 190-fold more detectable than the original  
5 jellyfish gene. When humanized GFP is stably integrated as part of the *gfp-neo* cassette of the rAAV provirus in G418-resistant cell lines, a considerable portion of the cells express a visually detectable GFP.

According to previously published data, rAAV integrates as a tandem repeat  
10 with the number of genome copies per cell ranging from 1 to 10 (Cheung *et al.*, 1980; Laughlin *et al.*, 1986; McLaughlin *et al.*, 1988; Samulski *et al.*, 1989). Therefore, the range of 1 to 10 copies of humanized GFP per cell under the control of a strong promoter, as described herein, can be detected. For certain GFP mutants, this number could be as low as one.

As an example of versatile vectors for use with the humanized GFP, rAAV  
15 vectors are provided. The design of the pTR<sub>BS</sub>-UF (User-Friendly) series of vectors (FIG. 2A) provides convenience and flexibility in the construction of rAAV vectors. To use the maximum cloning capacity of 5 Kbp the whole reporter gene cassette can be deleted by digestion with *Bgl*II, thus leaving the two terminal repeats of AAV  
20 which are the only sequences required for replication and packaging of AAV DNA.

The pTR<sub>BS</sub>-UF series contains two reporter gene cassettes, GFP and *neo*, each with its own promoter and polyadenylation signal. These two transcription units can be independently deleted (*Kpn*I-*Not*I digest for GFP and *Sal*I digest for *neo*), which increases the cloning space for the gene of interest. Even if used as is, the vector can  
25 accommodate another transcription unit of up to 1.6 Kbp.

Furthermore, the efficiency of a particular promoter in any given cell type or tissue could also be tested by substituting it for the CMV promoter upstream of the *gfp* gene after digesting the vector DNA with *Kpn*I and *Xba*I. The design of the



pTR<sub>BS</sub>-UF3 vector also allows for the coordinate expression of the reporter *gfp* gene and the gene of interest from the same promoter by the use of an IRES element.

In addition, the inventors describe the construction of an Ad shuttle vector, carrying the humanized GFP reporter gene under the control of the IRES element.

5 293 cells infected with recombinant Ad displayed typical CPE and bright green fluorescence. Expression of the GFP allowed for quick and easy selection of true recombinant Ad clones, discriminating them from false plaques.

The humanized GFP can also be incorporated into other viral and non-viral vector and expression systems. Using the humanized genes and vectors of the present invention, efficient transduction and expression of *gfp* gene sequences in mammalian and human cell lines is possible. This is exemplified by gene expression *in vivo* within neurosensory cells of guinea pig eye, shown herein. The humanized *gfp* genes have many uses, such as in cell sorting by fluorescence-activated cell sorting (FACS), and in human gene therapy.

15 Indeed, the system described herein is shown to mediate efficient transduction and expression of genes in cells of mammalian origin to a level sensitive enough to allow detection by simple FACS sorting. Selection of transduced cells with drugs, such as G418, or manipulation of cells for the visualization of enzymatic activities such as  $\beta$ -galactosidase, is thus eliminated. Since AAV and Ad, by way of example, 20 have a very broad host range, the described vectors will be useful in many gene delivery technologies, including human gene therapy.

### 1. Green Fluorescent Protein (GFP) Genes

Green fluorescent protein genes and functional proteins are believed to be present in a variety of organisms, as shown in Table 1. A *gfp* gene from any of the 25 bioluminescent cnidaria and ctenophora that express such genes can be used as the starting point for preparing a humanized *gfp* gene in accordance with the present invention.

TABLE 1

Bioluminescent Cnidaria and Ctenophora Exhibiting  
Green Fluorescent Protein (GFP)

Phylum/Class	Genus	Reference
Cnidaria,	<i>Aequorea</i>	Morin and Hastings, 1971
Hydrozoa	<i>Obelia</i>	Morin and Hastings, 1971
	<i>Phiallidium</i>	Morin and Hastings, 1971
	<i>Mitrocoma</i>	Prasher, 1995
	* <i>Campanularia</i>	Morin and Hastings, 1971
	* <i>Clytia</i>	Morin and Hastings, 1971
	* <i>Lovenella</i>	Morin and Hastings, 1971
	* <i>Diphyes</i>	Morin and Hastings, 1971
Cnidaria,	<i>Renilla</i>	Wampler <i>et al.</i> , 1973
Anthozoa	<i>Ptilosarcus</i>	Wampler <i>et al.</i> , 1973
	<i>Stylatula</i>	Wampler <i>et al.</i> , 1973
	<i>Acanthoptilum</i>	Wampler <i>et al.</i> , 1973

5

\*Existence of GFP deduced from *in vivo* green fluorescence

It is currently preferred that the *gfp* gene sequence from *A. victoria* be used as the template for creating a humanized *gfp* gene, as this is readily available.

10 Although biologically functional equivalents of *gfp* gene sequences are naturally encompassed by the present invention, it should be noted that attempts to truncate the gene have shown that only one residue can be sacrificed from the amino terminus and less than 10 or 15 from the carboxyl terminus before fluorescence is lost (Dopf and Horiagon, 1995). Therefore, substantially truncated *gfp* genes are not  
15 contemplated to be particularly useful. However, one use for such proteins may lie in high level GFP production in mammalian cells for subsequent use in antibody generation.

## 2. Green Fluorescent Proteins

*Aequorea* GFP is a protein of 238 amino acid residues. Its biggest absorbance peak is at 395 nm with a smaller peak at 475 nm. The amplitudes of these peaks (*i.e.* extinction coefficients) have been estimated as 21-30 and 7-15  $\text{mM}^{-1} \text{cm}^{-1}$ ,  
5 respectively (Morise *et al.*, 1974). Excitation at 395 nm yields an emission maximum at 508 nm. The quantum yield, or probability of re-emitting a photon once the molecule has been excited, is 0.72-0.85 (Morise *et al.*, 1974), and the excited state lifetime is 3.25 ns (Perozzo *et al.*, 1988).

The GFPs are unusually stable proteins, so their spectral properties are  
10 relatively unaffected in denaturing solutions. The purified protein also resists most proteases for many hours (Ward, 1981, 1982; Ward and Bokman, 1982; Cutler and Ward, 1993). However, on denaturation, GFP will lose its fluorescence (Ward *et al.*, 1980). In neutral aqueous buffer solutions, the temperature at which half the fluorescence is lost was found to be 78°C for *Aequorea* GFP (Ward, 1981). While the  
15 *Aequorea* GFP can be denatured with total loss of fluorescence using treatments of 6 M guanidine-HCl (2 min at 92°C), acidification of pH 2 or alkalization to pH 13, it is possible to renature GFP and recover fluorescence (Ward and Bokman, 1982). There appears to be a thiol requirement for this renaturation (Surpin and Ward, 1989).

There is no absolute requirement for another *Aequorea* factor to form the GFP  
20 chromophore, *p*-hydroxy zylideneimidazolinone, which is formed by cyclization of Ser65, Tyr66 and Gly67 and 1,2-dehydrogenation of the tyrosine. The mechanism of this unique post-translational modification is a constraint on the speed with which GFP can report changes in gene expression.

Denatured protein or isolated peptides containing the chromophore absorb  
25 light but are practically nonfluorescent (Ward *et al.*, 1980), presumably because the naked chromophore is neither rigid nor protected from jostling by solvent molecules. Chromophore formation must, of course, remain functional in any useful GFP mutant or fusion.

In yeast and HeLa cells, GFP expressed at 37°C is many times less fluorescent than that expressed at 15°C. Heat acts mainly by causing improper maturation rather than by decreasing expression levels or the brightness of properly matured GFP (Lim *et al.*, 1995).

- 5 Wild-type *Aequorea* GFP excited with fluorescein filters is about an order of magnitude less bright than the same number of molecules of free fluorescein. Switching the excitation to 395 nm does not help because such wavelengths cause rapid photoisomerization and also excite more background autofluorescence.

### 3. GFP Mutants and Variants

- 10 GFP originally cloned from *A. victoria* has several nonoptimal properties including low brightness, as described above, a significant delay between protein synthesis and fluorescence development and complex photoisomerization. However, GFP could be re-engineered with the aim of providing second generation compounds in which these deficiencies are lessened or overcome and in which the excitation and  
15 emission wavelengths are shifted, creating different colors and new applications.

- Most mutations in GFP result in a partial or complete loss of fluorescence without significant change in relative absorption or emission peaks. These mutations probably cause misfolding of the protein, failure of chromophore formation, or quenching of the fluorescence by insufficient shielding. Attempts to truncate the gene  
20 have shown that only one residue can be sacrificed from the amino terminus and less than 10 or 15 from the carboxyl terminus before fluorescence is lost (Dopf and Horiagon, 1995). The intolerance of GFP to major truncation is perhaps not too surprising, because the protein scaffold must both synthesize the chromophore and rigidly shield it from the surrounding water.

- 25 Amino acid replacements in the GFP polypeptide have already been reported to yield proteins with different spectral properties. A subset of mutations affect the relative ratio of absorption peaks, at 395 and 475 nm, presumably promoting or

hindering deprotonation of the chromophore. Examples are T203I (Thr203→Ile) and E222G (Glu222→Gly), which simplify the spectra to single absorption peaks at either 395 or 475 nm, respectively (Ehrig *et al.*, 1995). The mutation I167T (Ile167→Thr) inverts the wild-type ratio of the two peaks without eliminating either completely  
5 (Heim *et al.*, 1994).

A second subset of mutations produce essentially new excitation and emission spectra with significantly altered characteristics. Examples of this type of mutation are found within the chromophore region itself.

#### (a) Tyr66 Variants

10 The GFP from *Aequorea* and that of the sea pansy *Renilla reniformis* share the same chromophore, yet *Aequorea* GFP has two absorbance peaks at 395 and 475 nm, whereas *Renilla* GFP has only a single absorbance peak at 498 nm, with  $\approx 5.5$ -fold greater monomer extinction coefficient than the major 395-nm peak of the *Aequorea* protein (Ward, 1981). For many practical applications, the spectrum of *Renilla* GFP  
15 would be preferable to that of *Aequorea* because wavelength discrimination between different fluorophores and detection of resonance energy transfer are easier when the component spectra are tall and narrow rather than low and broad.

Furthermore, the longer wavelength excitation peak (475 nm) of *Aequorea* GFP is almost ideal for fluorescein filter sets and is resistant to photobleaching but  
20 has lower amplitude than the shorter wavelength peak at 395 nm, which is more susceptible to photobleaching (Chalfie *et al.*, 1994). For the foregoing reasons, conversion of the *Aequorea* GFP excitation spectrum to a single peak, preferably at longer wavelengths, is desirable.

Such a conversion was achieved by Heim *et al.* (1994), who described GFP  
25 mutagenesis and screening in which GFP variants with altered spectra were isolated. Replacement of the central tyrosine (Y66) by other aromatic amino acids (Trp, His or Phe) shift the excitation and emission spectra to progressively shorter wavelengths.

Heim *et al.* (1994) performed random mutagenesis of the *gfp* cDNA using hydroxylamine treatment (Sikorski and Boeke, 1991) and by increasing the error rate of the PCR<sup>TM</sup> with 0.1 mM MnCl<sub>2</sub>, 50 μM dATP, and 200 μM of dGTP, dCTP, and dTTP (Muhlrad *et al.*, 1992). Colonies on agar were visually screened for different emission colors and ratios of brightness when excited at 475 vs. 395 nm, supplied by a xenon lamp and grating monochromator for which the output beam was expanded to illuminate an entire culture dish.

A mutant was isolated by Heim *et al.* (1994) that was excitable by UV light and fluoresced bright blue in contrast to the green of wild-type protein. The excitation and emission maxima were hypsochromically shifted by 14 and 60 nm, respectively, from those of wild-type GFP. The mutated DNA of the critical protein contained a Tyr66→His change in the center of the chromophore. The fluorescence spectra of Tyr66His are not sensitive to pH changes until the protein is on the verge of denaturation, which provides additional evidence that the chromophore is inaccessible to solvent.

Further site-directed mutagenesis of tyrosine to tryptophan and phenylalanine was carried out (Heim *et al.*, 1994). Tryptophan gave excitation and emission wavelengths intermediate between tyrosine and histidine but was only weakly fluorescent, perhaps due to inefficiency of folding or chromophore formation, whereas phenylalanine gave no detectable fluorescence.

Although the Tyr66→His mutant is less fluorescent than wild-type GFP, presumably because the alternative amino acids fit less well into the central cavity, it is of course an important variant. The availability of several forms of GFP with different excitation and emission maxima facilitates two-color assessment of differential gene expression, developmental fate and protein trafficking, as discussed below.

#### (b) Ser65 Variants

The desire to create GFP variants with spectra much closer to that of *Renilla* also motivated the studies of Heim *et al.* (1995). Serine 65 of the amino-acid sequence of *Aequorea* GFP becomes part of the <sup>o</sup>*p*-hydroxybenzylideneimidazolinone chromophore. To test the hypothesis that Ser 65 undergoes additional dehydration to form a vinyl side chain, Heim *et al.* (1995) mutated that residue to Ala, Leu, Cys or Thr. If a vinyl group were formed by elimination of H<sub>2</sub>O or H<sub>2</sub>S, Ser and Cys should give identical spectra very different from Ala and Leu in which elimination is impossible.

Heim *et al.* (1995) produced four mutants showing single excitation peaks, located at 470-490 nm, whose amplitudes were four to sixfold greater than that of wild-type GFP for equal numbers of molecules. These results exclude vinyl formation. The Ser65→Thr mutant was selected for further characterization as it had the longest wavelengths of excitation and emission (490 and 510 nm), which closely resembled those reported for *Renilla* GFP (498 and 508 nm).

The crucial post-translational oxidation to produce the fluorophore from the nascent polypeptide chain proceeded about fourfold more rapidly in S65T than in the wild-type protein (Heim *et al.*, 1995). This acceleration ameliorates a potentially significant limitation in using GFP as a reporter protein for rapid gene inductions.

Mutations of Ser 65 to Arg, Asn, Asp, Phe, and Trp gave fluorescence intensities well below that of wild type.

In summary, the advantageous properties of the Ser65Thr GFP variant (Heim *et al.*, 1995) include: about sixfold greater brightness than wild-type when each is excited at its longest-wavelength peak; fourfold faster oxidation to the final fluorescent species than wild-type; and no photoisomerization and only very slow photobleaching. Preliminary findings indicate that Ser65Thr photobleaches at about 1/7 the rate of fluorescein at 488 nm irradiation in air-saturated buffer at pH7.1. As the extinction coefficient of Ser65Thr is about 4/7 that of fluorescein under these

conditions, the quantum efficiency of photobleaching of Ser65Thr may be calculated to be about 1/4 that of fluorescein.

These advantages make Ser65Thr more attractive than wild-type GFP for most applications except those in which long-wave UV excitation or photo-isomerization is essential. It will particularly provide greater sensitivity using commonly available  
5 fluorescein isothiocyanate (FITC) filter sets (450-490 nm excitation).

**(c) Other Red-Shifted Mutants**

Delagrave *et al.* (1995) have also performed extensive random mutagenesis of GFP residues 64-69 and isolated six mutants whose spectra are qualitatively similar to  
10 the Ser65 mutants described above. Four of them have the same substitutions (Leu, Cys or Ala) at position 65 as listed above.

The methods used by Delagrave *et al.* (1995) for the construction of spectrally shifted GFP mutants have previously been employed to produce a variety of spectrally diverse bacteriochlorophyll-binding proteins using optimized combinatorial  
15 mutagenesis and Digital Imaging Spectroscopy (DIS) (Goldman and Youvan, 1992; Delagrave and Youvan, 1993).

DIS enables simultaneous screening of thousands of colonies directly on petri dishes by acquiring spatially resolved spectral information (Youvan *et al.*, 1995; Youvan, 1994). Images of petri dishes, illuminated at different wavelengths, are  
20 captured by a charge-coupled device (CCD) camera and further processed by software establishing radiometric calibration. Using optimized combinatorial mutagenesis and DIS, further GFP mutants can be isolated.

In the combinatorial library screening of Delagrave *et al.* (1995), the region of GFP targeted for mutagenesis was the 6 amino acid sequence between Ple64 and  
25 Glu69 (Phe Ser Tyr Gly Val Gln; SEQ ID NO:4) which includes the chromophore itself. A mutagenic oligonucleotide was designed to favor the incorporation of an aromatic amino acid at position 66 and to fully randomize the other five codons. The



sequence of the oligonucleotide employed for mutagenesis was obtained using the CyberDope computer program.

The resulting library of approximately  $3 \times 10^5$  mutant GFP genes was expressed in B121 (DE3). Thousands of colonies on petri dishes were screened by fluorescence using DIS (Delagrave *et al.*, 1995). The spectrally shifted mutants were initially identified by the green fluorescence observed when excited with 490 nm light, which disappears when excited at 410 nm. In contrast, wild-type GFP fluorescence is much brighter with 410 nm illumination. DIS revealed that approximately one in  $10^4$  colonies expressed a functional fluorescent protein.

Delagrave *et al.* (1995) picked and sequenced several red-shifted GFP (RSGFP) clones. Tyr66 and gly67 appeared to be conserved while the other four positions were less stringent; ser<sup>65</sup> was not necessary for the observed phenotype. RSGFPs are easily distinguished from wild-type GFP because their excitation maxima are red-shifted by about 100 nm, from 390 nm in wild-type *Aequorea* GFP to 490 nm in RSGFP. One particular clone is RSGFP4, which has the chromophore sequence Met Gly Tyr Gly Val Leu (SEQ ID NO:5). The emission of RSGFP4 is nearly identical to that of wild-type GFP, but the excitation spectra are very different.

Delagrave *et al.* (1995) reported that this sequence information is amenable to further manipulation by Exponential Ensemble Mutagenesis (EEM) and Recursive Ensemble Mutagenesis (REM) strategies (Delagrave and Youvan, 1993; Delagrave *et al.*, 1993), potentially to produce a 'rainbow' of multispectral fluorescent proteins. It is expected that by constructing new combinatorial libraries optimized by REM or EEM, the frequency of functional mutants will be high enough to allow the isolation of rare clones with significant emission shifts.

#### 4. Humanized gfp Genes

Although the properties of wild-type GFP are improved in mutants, such as described above, wild-type GFP lacks one stage of amplification built into a true

enzymatic reporter system in which each protein molecule can generate thousands of chromophore or fluorophore molecules. Because each GFP represents one fluorophore, relatively high levels of GFP expression, as much as  $10^6$  molecules per cell (Rizzuto *et al.*, 1995) may be necessary to give bright signals.

5           The foregoing emphasizes the importance of the present invention, the focus of which is to provide for increased GFP expression in mammalian and human cells. Each of the mutants described above, or indeed any desired mutant or a panel of mutants, can also be prepared in a humanized background as provided by the present invention. This is because the humanizing aspects of the invention change the DNA  
10           sequence independently of the protein sequence.

          Previous attempts to express GFP in mammalian cells have used the Kozak consensus (Adams *et al.* 1995). A so-modified GFP gene has been inserted into a mammalian expression vector and used in CHO-K1 cells (Adams *et al.* 1995). Pines (1995) has also reported transient GFP expression COS-7, HeLa and NIH 3T3 cells;  
15           and Rizzuto *et al.* (1995) have reported expression of GFP in mitochondria of intact cells. However, these studies are believed to reflect relatively low level expression and, furthermore, are believed to be in contrast to the negative results obtained by many of those working in the art. These few positive results are believed to be a function of the high copy number of *gfp* genes introduced into the cell.

20           The approach taken by the present inventors is in contrast to the Adams *et al.* (1995) method, and addresses the poor translation efficiency of GFP mRNA in the human cell environment by using cDNAs that contain base substitutions in order to change the codon usage so that it is more appropriate for expression in mammalian cells. Using such humanized constructs results in green fluorescence in cells that have  
25           a low copy number of humanized *gfp* genes, e.g., in the range of less than 10, and even about 1 or 2 when using certain humanized *gfp* mutant genes.

          The correlation between the abundance of tRNAs and the occurrence of the respective codons in protein-expressing genes has been described for *E. coli*, yeast

and other organisms (Bennetzen and Hall (1982); Grantham *et al.* (1980); Grantham *et al.* (1981); Ikemura (1981a; 1981b; 1982); Wada *et al.* (1990)). However, until codon changes are actually made in any given gene, their effects on translation efficiency and overall expression levels cannot be established. This is similar to the situation involving the Kozak sequence, which is not believed to have been particularly helpful in increasing expression of *gfp* in mammalian cells despite expectations. Now that the present inventors have shown that humanization is effective for *gfp* gene expression, the usefulness of the GFP technology has been significantly enhanced.

10 In order to humanize jellyfish *gfp* in accordance with the present invention, the inventors first conducted a detailed analysis of the codons in the *gfp* gene. Table 2 shows the results of a comparison between jellyfish *gfp* codons and codons commonly used in human genes (Wada *et al.*, 1990). This enabled the inventors to identify important differences between *gfp* and general human gene sequences and to identify  
15 changes that should be made.

An exemplary humanized sequence in accordance with the present invention is represented by SEQ ID NO:3. However, it will be understood that the humanized sequences of the present invention are by no means limited to the representative sequence of SEQ ID NO:3. Rather, in light of the following instructions, one of skill  
20 in the art will readily be able to prepare a number of different humanized *gfp* sequences.

Although any changes that replace a rarely used jellyfish codon with a codon that is more frequently used in human genes are considered to be useful changes, certain codon changes will naturally be preferred over others. In this regard, the  
25 inventors have identified a number of *gfp* codons that are rarely or almost never used in human genes. As discussed below, such codons are the first candidates that should be changed in producing a humanized gene in accordance with the present invention.

In making general humanizing changes, codons to be humanized can be identified by those of skill in the art from studying the information presented herein in Tables 2 and in Table 3 and 4. For example, in utilizing the information in Table 2, one would compare the frequency of the jellyfish codon against the frequency of those codons commonly used in human genes, and make any appropriate changes. By way of an example only, consider the amino acid leucine; the codon CUU is used eleven times in the *gfp* gene, but this codon corresponds to only the fourth preferred codon in human genes. The leucine codon UUA also features prominently in the jellyfish gene, and this codon is the last choice for use in the human genome. Changing the Leucine codons would thus make an appropriate starting point for preparing a humanized gene.

Further changes that can be made following an analysis of Table 2 are to change the arginine codons of AGA, which is only a fourth choice in the human genome, to a more preferable codon such as CGC or AGG; changing Serine codons such as UCG or UCA to more preferred codons such as UCC and AGC; optimizing threonine codons to ACC; avoiding the use of the proline codon GCC; changing the alanine codon GCA to the most preferred human codon CGG; avoiding the use of the predominant glycine codons GGA and GGU and replacing these with those preferred in human genes, GGC and GGG; changing the frequently occurring valine codons GUU and GUA, and instead using the codon GUG, which is clearly favored in the human genome; and avoiding the isoleucine codon AUA and changing this to the preferred codon AUC.

In the amino acids for which there is only a choice of two codons, the inventors noticed that the wild type *gfp* gene usually employs the least preferred codon as compared to the human genome. Therefore, appropriate changes would be made in the following codons AAA for lysine; CAA for glutamine; CAU for histidine; GAA for Glutamine; GAU for Asparagine; and UUU for Phenylalanine; and replacing these with AAG, CAG, CAC, GAG, GAC, and UUC, respectively.

Additional changes can also be made from considering the information in Table 3 and Table 4. These tables provide important information regarding codon preference in a format that is easily used. Table 3 provides a list of the codons that are preferred for use in the humanized *gfp* constructs of the invention. Table 4 is simply  
5 the same information that incorporates U (uridine) rather than T (thymine), for ready cross-reference with FIG. 1.

**Table 3: Preferred DNA Codons for Human Use**

<u>Amino Acids</u>			<u>Codons Preferred in Human Genes</u>						
Alanine	Ala	A	GCC	GCT	GCA	GCG			
Cysteine	Cys	C	TGC	TGT					
Aspartic acid	Asp	D	GAC	GAT					
Glutamic acid	Glu	E	GAG	GAA					
Phenylalanine	Phe	F	TTC	TTT					
Glycine	Gly	G	GGC	GGG	GGA	GGT			
Histidine	His	H	CAC	CAT					
Isoleucine	Ile	I	ATC	ATT	ATA				
Lysine	Lys	K	AAG	AAA					
Leucine	Leu	L	CTG	CTC	TTG	CTT	<u>CTA</u>	<u>TTA</u>	
Methionine	Met	M	ATG						
Asparagine	Asn	N	AAC	AAT					
Proline	Pro	P	CCC	CCT	CCA	CCG			
Glutamine	Gln	Q	CAG	CAA					
Arginine	Arg	R	CGC	AGG	CGG	AGA	CGA	CGT	
Serine	Ser	S	AGC	TCC	TCT	AGT	TCA	<u>TCG</u>	
Threonine	Thr	T	ACC	ACA	ACT	ACG			
Valine	Val	V	GTG	GTC	GTT	<u>GTA</u>			
Tryptophan	Trp	W	TGG						
Tyrosine	Tyr	Y	TAC	TAT					

5 The codons at the left represent those most preferred for use in human genes, with human usage decreasing towards the right.

Double underlined codons represent those which are almost never used in human genes.

**Table 4: Preferred RNA Codons for Human Use**

<u>Amino Acids</u>			<u>Codons Preferred in Human Genes</u>						
Alanine	Ala	A	GCC	GCU	GCA	GCG			
Cysteine	Cys	C	UGC	UGU					
Aspartic acid	Asp	D	GAC	GAU					
Glutamic acid	Glu	E	GAG	GAA					
Phenylalanine	Phe	F	UUC	UUU					
Glycine	Gly	G	GGC	GGG	GGA	GGU			
Histidine	His	H	CAC	CAU					
Isoleucine	Ile	I	AUC	AUU	AUA				
Lysine	Lys	K	AAG	AAA					
Leucine	Leu	L	CUG	CUC	UUG	CUU	<u>CUA</u>	<u>UUA</u>	
Methionine	Met	M	AUG						
Asparagine	Asn	N	AAC	AAU					
Proline	Pro	P	CCC	CCU	CCA	CCG			
Glutamine	Gln	Q	CAG	CAA					
Arginine	Arg	R	CGC	AGG	CGG	AGA	CGA	CGU	
Serine	Ser	S	AGC	UCC	UCU	AGU	UCA	<u>UCG</u>	
Threonine	Thr	T	ACC	ACA	ACU	ACG			
Valine	Val	V	GUG	GUC	GUU	<u>GUA</u>			
Tryptophan	Trp	W	UGG						
Tyrosine	Tyr	Y	UAC	UAU					

5 The codons at the left represent those most preferred for use in human genes, with human usage decreasing towards the right.

Double underlined codons represent those which are almost never used in human genes.

From studying the information in Table 3 and Table 4, one of skill in the art would readily discern that the jellyfish *gfp* codons CTA, TTA, TCG and TCA (or CUA, UUA, UCG or GUA) should be changed to a more preferred codon. As a general guideline, those codons listed in columns 5 and 6 generally represent codons that one would prefer to change in creating a humanized gene; the codons listed in column 4 should also often be changed in creating a humanized gene; the codons listed in column 3 may or may not be changed, depending on the number of changes that one wishes to make in total and on the particular amino acid that is to be encoded. Those codons listed in columns 1 and 2, when occurring in the wildtype *gfp* sequence, will generally be appropriate and should not need changing, unless there is only a choice of two codons available. However, replacing a codon from column 2 with a codon from column 1 is certainly a useful option, particularly where there is only a choice of two codons. Given this information, it will now be understood that, when introducing changes into the *gfp* sequence, one would generally desire to introduce a codon of column 1 wherever possible.

In light of the foregoing discussion, it will be clear that the exemplary sequence of SEQ ID NO:3 is only one of the many operable species that are encompassed by the present invention. In SEQ. ID NO:3, 88 codons contain one or more base substitutions. 88 codons from a sequence that encodes 328 amino acids represents a change of about 37%. However, it is contemplated that changing about 10% of the codons would produce a useful increase in expression levels and such gene sequences therefore fall within the scope of the present invention. Changing about 15%, 20%, 25% or 30% of the codons within the jellyfish *gfp* sequence is also considered to be useful and the humanized genes of this invention encompass those gene sequences that fall within the aforementioned ranges.

In certain embodiments, depending on the nature of the codon changes introduced, it may not be necessary to even make a 10% change in the codon usage of the *gfp* gene. For example, if each of the ten least favored codons were to be changed and replaced with those most preferred for use in human genes, it is contemplated that



the resultant sequence may achieve reasonable expression in human and mammalian cells. Changing ten codons from within 328 represents a percentage change of about 4%. Therefore, so-called "4% humanized genes" also fall within the scope of the present invention given the following provision - that when making only a limited number of changes, one would generally wish to change the ten codons located at codon positions 18, 53, 93, 125, 150, 178, 195, 208, 236 and 224 of the *gfp* gene sequence. When making these key changes along with a number of other changes, it is contemplated that changing at least about 7, 8 or 9 of these codons will be sufficient to result in a humanized gene with improved expression. As described above, leucine would preferably be encoded by CTG, CTC or TTG; valine would preferably be encoded by GTG; and serine would preferably be encoded by AGC.

Although *gfp* gene sequences in which about 4-5, about 10, about 20 or about 30-35% of the codons have been changed will generally be preferred, there is no reason that further changes should not be made if so desired. Humanized gene sequences in accordance with the present invention may therefore be sequences that contain humanized codons at about 40%, 50%, 60%, 70% or even about 80-90% of the codon positions within the full length codon region. In reviewing SEQ ID NO:3, with a view to introducing still further humanizing changes, a number of positions are identifiable in which further optimizing changes could be introduced. These include, for example, those codons found at codon positions 6, 9, 14, 17, 19, 21, 23, 26, 27, 31, 33, 34, 35, 36, 40, 45, 50, 51, 62, 71, 83, 99, 101, 102, 111, 115, 116, 128, 130, 132, 133, 134, 136, 142, 157, 171, 173, 174, 181, 183, 186, 209, 210, 213, 223 and 230 of SEQ. ID NO:3.

## 5. Uses of Green Fluorescence Proteins

The potential of GFP as a reporter molecule stems from properties such as ready detection, it can be detected on irradiation using standard long-wave UV light sources; the possibility of real-time detection *in vivo*; the fact that the introduction of a

substrate is not required; and its relatively small size (26.9 kD) and monomeric nature, which make protein fusions manageable.

The humanized GFP of the present invention renders several of these methods practical rather than speculative. Humanized *gfp* genes can therefore be used to  
5 identify transformed cells, *e.g.*, by fluorescence-activated cell sorting (FACS) or fluorescence microscopy; to measure gene expression *in vitro* and *in vivo*; to label specific cells in multicellular organisms, *e.g.*, to study cell lineages; to label and locate fusion proteins; and to study intracellular trafficking and the like.

Standard biological applications of GFP should not be overlooked. For  
10 example, its use as a molecular weight marker on protein gels and Western blots, in calibration of fluorometers and FACS machines and in microinjection into cells and tissues.

In methods to produce fluorescent molecular weight markers, a humanized *gfp*  
15 gene sequence is generally fused to one or more DNA sequences that encode proteins having defined amino acid sequences and the fusion proteins are expressed from an expression vector. Expression results in the production of fluorescent proteins of defined molecular weight or weights that may be used as markers (following calculation of the size of the complete amino acid).

Preferably, purified fluorescent proteins would be subjected to size-  
20 fractionation, such as by using a gel. A determination of the molecular weight of an unknown protein is then made by compiling a calibration curve from the fluorescent standards and reading the unknown molecular weight from the curve.

#### (a) Different colored GFPs

As mentioned, amino acid replacements in humanized GFP that produce  
25 different color forms permit simultaneous use of multiple reporter genes. Different colored humanized GFPs can be used simply to identify multiple cell populations in a mixed cell culture or to track multiple cell types, enabling differences in cell

movement or migration to be visualized in real time without the need to add additional agents or fix or kill the cells.

Other options include tracking and determining the ultimate location of multiple proteins within a single cell, tissue or organism; differential promoter analysis in which gene expression from two different promoters is determined in the  
5 same cell, tissue or organism; and FACS sorting of mixed cell populations.

In tracking proteins within a cell, the humanized GFP variants would be used in a analogous manner to fluorescein and rhodamine and would tag interacting proteins or subunits whose association could then be monitored dynamically in intact  
10 cells by fluorescence resonance energy transfer (Adams *et al.*, 1991; 1993).

The techniques that could be used with spectrally separable humanized GFP derivatives are exemplified by confocal microscopy, flow cytometry, and fluorescence activated cell sorting (FACS) using modular flow, dual excitation techniques.

#### **(b) Identification of Transfected Cells**

The many ways in which humanized *gfp* may be used can be divided into  
15 certain broad areas. First, to simply identify cells. In these methods, humanized *gfp* is used alone to express GFP in a cell. One use for this method would be in pre-labeling isolated cells or a population of similar cells prior to exposing the cells to an environment in which different cell types are present. Detection of GFP in only the  
20 original cells allows the location of such cells to be determined and compared with the total population.

A second group of methods concerns the identification of cells that have been transfected with exogenous DNA of interest. Identifying cells transfected with exogenous DNA is required in many *in vitro* embodiments and, also, in *in vivo* gene  
25 therapy.

A first example of this general group is where a humanized *gfp* sequence is fused to a DNA sequence encoding a selected protein in order to directly label the

5 encoded protein with GFP. Expressing such a humanized GFP fusion protein in a cell results in the production of fluorescently-tagged proteins that can be readily detected. This is useful in simply confirming that a protein is being produced by a chosen host cell. It also allows the location of the selected protein to be determined, whether this represents a natural location or whether the protein has been targeted to an organelle by the hand of man.

10 Cells that have been transfected with exogenous DNA can also be identified without creating a fusion protein. Here, the method relies on the identification of cells that have received a plasmid or vector that comprises at least two transcriptional or translational units. A first unit will encode and direct expression of the desired protein, while the second unit will encode and direct expression of humanized GFP. Co-expression of GFP from the second transcriptional or translational unit ensures that cells containing the vector are detected and differentiated from cells that do not contain the vector.

### 15 (c) Analysis of Promoters

20 The humanized genes of this invention also provide another dimension to the analysis of promoters in mammalian cells. As *gfp* can now be expressed in mammalian and human cells and readily detected, a range of promoters can be tested for their suitability for use with a given gene, cell, or system. This applies to *in vitro* uses, such as in identifying a suitable promoter for use in recombinant expression and high level protein production, and also in *in vivo* uses, such as in pre-clinical testing or in gene therapy in human subjects.

25 In practical terms, to analyze a promoter one would first establish a control cell or system. In the control, a positive result can be established by using a known and effective promoter, such as the CMV promoter preferred in certain aspects of the studies described herein. To test a candidate promoter, another cell or system will be established in which all conditions are the same except for there being different promoters in the expression vector or genetic construct. After running the assay for

the same period of time and under the same conditions as in the control, the ultimate GFP expression levels would be determined. This allows a comparison of the strength or suitability of the candidate promoter with the standard promoter to be made. In using a GFP expression system that is routinely employed in a given laboratory, the positive control may even be dispensed with in certain studies of a test promoter.

Promoters that can be tested in this manner also include candidate tissue-specific promoters and candidate-inducible promoters. Testing of tissue-specific promoters allows preferred or optimal promoters for use with a given cell to be identified and distinguished from a range of possible promoters. Again, this will be useful both *in vitro* and *in vivo*. Optimizing the combination of a given promoter and a given cell type in recombinant expression and protein production can often be necessary to ensure that the highest possible levels are achieved.

It is even contemplated that these aspects of the invention could be used to analyze a candidate promoter for use in protein production employing a secretory cell. In these embodiments, the GFP expressed from the promoter would most likely be secreted from the cell into the extra cellular environment where it would then be detected.

The testing and ultimate use of inducible promoters forms another aspect of this invention. In recombinant expression for the purposes of protein production, it may be desired to induce expression at a particular stage of the cell culture or cell cycle. In analyzing the distribution of a given protein within a cell or a given system, it is also useful to use a promoter that is only switched on under certain conditions, such as in the presence of certain cytokines or hormones.

The use of humanized *gfp* genes with inducible promoters also extends to an analysis of the promoter itself. An example here is in the analysis of a particular promoter from a group of promoters, such as promoters associated with heat shock proteins, that are known to be expressed in various organisms throughout evolution.

In this way, a promoter operable in, for example, yeast, can be taken and expressed in a mammalian cell system in order to determine whether it is operable in mammalian cells and, therefore, to determine whether mammalian cells likely include a homolog of the yeast promoter.

5           The use of tissue-specific promoters and inducible promoters is particularly powerful in *in vivo* embodiments. When used in the context of expressing a therapeutic gene in an animal, the use of such a promoter will allow expression only in a given tissue or tissues, at a given site and/or under defined conditions. This is a significant advantage which allows gene expression to be confined to a particular  
10 target organ, tissue or area, and will limit gene expression throughout the rest of the body. Achieving tissue-specific expression is particularly important in certain gene therapy applications, such as in the expression of a cytotoxic agent, as is often employed in the treatment of cancer. In expressing other therapeutic genes with a beneficial affect, tissue-specific expression is, of course, also preferred in that it  
15 optimizes the affect of the treatment.

          Appropriate tissue-specific and inducible promoters will be known to those of skill in the art. By way of example only, one may mention the liver fatty acid binding (FAB) protein gene promoter, specific for colon epithelial cells; the insulin gene promoter, specific for pancreatic cells; the transphyretin,  $\alpha$ 1-antitrypsin, plasminogen  
20 activator inhibitor type 1 (PAI-1), apolipoprotein AI and LDL receptor gene promoters, each directing specific or preferential expression in liver cells. Promoters active in brain tissues include the myelin basic protein (MBP) gene promoter, specific for oligodendrocytes; the glial fibrillary acidic protein (GFAP) gene promoter, specific for glial cells; and the neural-specific enolase (NSE) promoter that is specific  
25 for nerve cells.

          Inducible promoters for *in vivo* uses will preferably include those responsive to biologically compatible agents, preferably those that are usually encountered in defined animal tissues. An example is the human PAI-1 promoter, which is inducible by tumor necrosis factor. Further suitable examples cytochrome P450 gene

promoters, inducible by various toxins and other agents; heat shock protein genes, inducible by various stresses; hormone-inducible genes, such as the estrogen gene promoter, and such like.

Promoters that are inducible by ionizing radiation may also be used in certain  
5       embodiments, particularly in gene therapy of cancer, where gene expression is  
induced locally in the cancer cells by exposure to ionizing radiation such as UV or x-  
rays. Appropriate promoters that are inducible by ionizing radiation include *egr-1*, *fos*  
and *jun*.

**(d)     Screening Protocols**

10       A further development of using promoters along with the humanized *gfp* of the  
present invention is its use in screening protocols. In these embodiments, which are  
generally conducted *in vitro*, a genetically engineered cell is used to identify the  
presence of a particular compound or agent in a composition.

15       In the screening embodiments, the humanized *gfp* gene will be positioned  
downstream of a promoter that is known to be inducible by the agent that one wishes  
to identify. Expression of *gfp* in the cells will normally be silent, and will be switched  
on by exposing the cell to a composition that contains the selected agent. In using a  
promoter that is responsive to, for example, a heavy metal, a toxin, a hormone, a  
cytokine or other defined molecule, the presence of a heavy metal, toxin, hormone,  
20       cytokine or such like can readily be determined.

From the foregoing list, it will be appreciated that the screening aspects of this  
invention fall into two basic groups, which may be conveniently termed 'the  
biological' and 'the chemical'.

25       In the biological assays, cells including a humanized *gfp* gene under the  
control of a promoter that is inducible by a biological effector molecule may be used  
to detect the presence of such molecules in various kinds of biological samples,  
including blood, plasma, semen, urine, saliva and the like. Those effector molecules

that are detectable in this way include molecules such as hormones, cytokines, neurotransmitters and the like. Of course, as used throughout this application, it will be understood that the term "promoter" is being used to refer to any regulatory element. Particular examples here are the use of the sterol regulatory element, in  
5 conjunction with humanized *gfp*, to detect sterols in a given composition; and the similar use of the serum response element, which is induced by UV, EGF, PDGF and TPA.

In the so-called chemical assays, cells including a humanized *gfp* gene under the control of a promoter that is inducible by a chemical agent are used to detect the  
10 presence of the chemical agent in various compositions. These assays may be used to detect toxins or contaminants in fluids such as drinking water, and the like. The types of agents that may be detected in this way include heavy metals, toxins and various other pollutants and undesirable chemicals.

It will, of course, be realized that any of the screening assays may be used in  
15 the context of detecting agents that inhibit, suppress or otherwise downregulate gene expression from a given promoter. Such negative effects will be detectable by falling levels of and decreased fluorescence that results when gene expression is "switching off" in response to the presence of an inhibitory agent.

#### (e) GFP in FACS Analyses

20 Many conventional FACS methods require the use of fluorescent dyes conjugated to purified antibodies. Proteins tagged with a fluorescent label would be preferred over antibodies in FACS applications because cells do not have to be incubated with the fluorescent-tagged reagent and because there is no background due to nonspecific binding of an antibody conjugate. GFP is particularly suitable for use  
25 in FACS as fluorescence is stable and species-independent and does not require any substrates or cofactors.

As with other expression embodiments, a desired protein may be directly labeled with GFP by preparing and expressing a GFP fusion protein in a cell. GFP



could also be co-expressed from a second transcriptional or translational unit within the expression vector that expresses desired protein, as described above. Cells expressing the GFP-tagged protein or cells co-expressing GFP would then be detected and sorted by FACS analysis. FACS analysis may be used as the end means to monitor gene expression and promoter activity when using GFP as the reporter gene.

Red-shifted GFPs are particularly suitable for use with FACS (although GFP itself can also be used). The argon ion laser used in most FACS machines emits at 488 nm, so excitation of red-shifted GFP variants (e.g., excitation peak approximately 490 nm) is more efficient than excitation of wild type GFP. The successful use of GFP with FACS techniques is shown herein.

## 6. GFP Fusion Proteins

Humanized *gfp* genes can be used as one portion of a fusion protein, allowing the location of the protein to be identified. Fusions of GFP with an 'exogenous' protein should preserve both the fluorescence of GFP and functions of the host protein, such as physiological functions and/or targeting functions.

Both the amino and carboxyl termini of GFP may be fused to virtually any desired protein to create an identifiable GFP-fusion. Both N- and C-terminal protein fusions prepared using the wild type gene have been reported (Wang and Hazelrigg, 1994). Fusion of proteins to the carboxyl terminus of GFP might be enhanced by linker sequences.

### (a) Subcellular Localization

Localization studies have been previously carried out by subcellular fractionation and by immunofluorescence. However, these techniques can give only a 'snapshot' of the position of the protein at one instant in the cell cycle. In addition, artefacts can be introduced when cells are fixed for immunofluorescence. Using GFP to visualize proteins in living cells, which enables proteins to be followed throughout the cell cycle in an individual cell, is thus an important technique.

Humanized GFP can be used to analyze intracellular protein traffic in mammalian and human cells under a variety of conditions in real time. Artefacts resulting from fixing cells are avoided. In these applications, humanized GFP is fused to a known protein in order to examine its sub-cellular location under different natural conditions.

Pines (1995) described the use of wild type GFP as a tag to create GFP-cyclin chimeras that were expressed in mammalian tissue-culture cells by transient transfection. In preliminary studies, GFP and both N- and C-terminal GFP-cyclin chimeras were detected in living cells, and the fluorescence was followed in such cells for several hours.

Pines (1995) used the cytomegalovirus early promoter to drive GFP expression in transiently transfected cells and expressed GFP in COS-7, HeLa and NIH 3T3 cells. In all cases there was a lag period (>15 h) before fluorescence was detected, although chimeras were detected by immunofluorescence after 12 h. This may be due to the requirement for GFP to autoxidize, which takes around 4 h in bacteria (Heim *et al.*, 1994). In contrast to these studies in mammalian cells, the present invention has the distinct advantage that GFP fluorescence was detectable is about 6 hours.

In the studies of Pines (1995) and others, GFP has not interfered with the natural subcellular localization of proteins. Pines (1995) showed that GFP alone is distributed throughout the cell, both in the nucleus and the cytoplasm. When tagged to cyclin A, it was found to be primarily nuclear, and when tagged to cyclin B, it was found to be cytoplasmic, associating with microtubules or the vesicle compartment depending on the B-type cyclin (Pines, 1995).

Humanized GFP may be used to tag virtually any protein and to follow the location of the protein under different conditions. For example, in following a given protein through meiosis, mitosis, apoptosis or other cellular processes. The location of a given protein can also be determined in response to a number of external stimuli.

Such stimuli include different physical conditions, such as increasing or decreasing temperature, and also different chemical environments. By the term "chemical environment", it is meant both natural environments that may be encountered, such as compositions with different levels of salt or serum growth factors and the like, and also compositions to which an effector molecule has been added.

Compositions with effector molecules are used in order to provoke a response in a given cell. The humanized *gfp* of the invention can be used in assays in which the response of a cell to a given effector or agonist is determined. By using such methods, the location of a given protein in response to a hormone, cytokine, neurotransmitter or other agent can be determined. It is well known that the location of proteins vary in response to varying external stimuli, and that proteins move between internal compartments, such as, e.g., the outer membrane, cytosol, endoplasmic reticulum and nuclear compartments.

#### (b) GFP-driven targeting

Another use of GFP-fusion proteins is in detecting a targeted protein in a particular locale after the protein has been adapted for transport into a particular cellular compartment despite the natural destination of the protein. To achieve this, a targeting sequence, such as a nuclear or mitochondrial targeting sequence, is fused to the desired protein along with the GFP sequence. This is in contrast to the methods described immediately above, where the natural location of a protein is determined using GFP.

The nucleus contains many proteins that help mediate its unique functions. These proteins are imported from the cytosol where they are made. They must pass through both the outer and inner nuclear membranes to reach the inside of the nucleus (the nuclear lumen). This transport process is selective: many proteins made in the cytosol are excluded from the nucleus. Many nuclear proteins interact with receptor proteins located on the pore margin that actively transport the proteins into the nucleus while enlarging the pore channel.

The selectivity of nuclear transport resides in nuclear import signals, which are present only in nuclear proteins. Nuclear import signals have been precisely defined in some nuclear proteins using genetic engineering techniques. The signal, which can be located anywhere in the protein, consists of a short peptide (typically from four to eight amino acid residues) that is rich in the positively charged amino acids lysine and arginine and usually contains proline. For example, the T-antigen nuclear import signal is Pro Pro Lys Lys Lys Arg Lys Val (SEQ ID NO:6).

Humanized GFP may be used to confirm that a selected protein has been imported into the nucleus following expression of a construct in which the protein in question is fused to GFP and a nuclear targeting sequence. This may be used as part of *in vitro* studies in basic science or even as part of *in vivo* therapy, e.g., in directing agents to the nucleus of cancer cells, and the like.

Adding a nuclear localization signal to a humanized *gfp* gene may also be used in order to enhance the fluorescence intensity of the expressed protein by confining the protein to the much smaller space of the nucleus. This is described herein in Example VII in the context of blue GFP mutants.

As a nuclear protein molecule needs to be repeatedly imported, e.g., after mitosis, its nuclear import signal peptide is not cleaved off after transport into the nucleus. In contrast, once a protein molecule has been imported by any of the other membrane-bounded organelles, it is passed on from generation to generation within that compartment and need never be translocated again. Therefore, the signal peptide on these molecules is often removed following protein translocation.

Mitochondria are double-membrane-bounded organelles that specialize in the synthesis of ATP-by electron transport and oxidative phosphorylation. Most of their proteins are encoded by the cell nucleus and imported from the cytosol. Moreover, each imported protein must reach the particular subcompartment in which it functions. For mitochondria there are four subcompartments: the matrix space; the inner

membrane; the intermembrane space; and the outer membrane that face the cytosol. Each of these subcompartments contains a distinct set of proteins.

5 The study of mitochondrial biogenesis has been facilitated by the use of yeasts, into which hybrid genes encoding fusion proteins (produced by recombinant DNA techniques) can be introduced efficiently. Proteins imported into the mitochondrial matrix are usually taken up from the cytosol within a minute or two of their release from free polyribosomes.

10 Imported proteins almost always have a signal peptide (20-80 residues long) at their amino terminus. After being imported, the signal peptide is rapidly removed by a specific protease (a signal peptidase) in the mitochondrial matrix and then probably is degraded to amino acids in the matrix. The signal peptide can be remarkably simple. Molecular genetic experiments in which the signal peptide is progressively reduced in length have shown that, for one mitochondrial protein, only 12 amino acids at the amino terminus are needed to signal mitochondrial import. These 12 residues  
15 can be attached to any cytoplasmic protein and will direct the protein into the mitochondrial matrix.

Physical studies of full-length signal peptides suggest that they can form amphipathic  $\alpha$ -helical structures in which positively charged residues all line up on side of the helix while uncharged hydrophobic residues line up toward the opposite  
20 side. An example of a mitochondrial import sequence is Met Leu Ser Leu Arg Gln Ser Ile Arg Phe Phe Lys Pro Ala Thr Arg Thr Leu (SEQ ID NO:7).

The transport of several precursor proteins to the mitochondrial intermembrane space begins with their initial transfer into the matrix. Here, a very hydrophobic amino acid sequence is strategically placed after the amino-terminal  
25 signal peptide that initiates import. Once the amino-terminal signal is cleaved by the matrix protease, the hydrophobic sequence functions as a signal peptide to reinsert the protein into the inner membrane. This transfer from the matrix presumably occurs by a mechanism similar to that used for protein import into the ER membrane, and it is

also the mechanism used to insert proteins that are encoded in the mitochondrion into the inner membrane. The transport of proteins from the cytosol to the mitochondrial inner membrane also requires a hydrophobic signal peptide.

The use of GFP and a mitochondrial targeting sequence to visualize mitochondrial movement in living cells has been reported by Rizzuto *et al.* (1995). In contrast to dyes such as rhodamine, using GFP revealed morphological changes induced in mitochondria by drugs that collapse the organelle membrane potential.

In these studies, Rizzuto *et al.* (1995) used a DNA fragment encoding the amino-terminal 31 amino acids of the precursor of sub-unit VIII of cytochrome c oxidase, which form a mitochondrial targeting sequence, as part of the fusion protein-encoding sequences. A chimeric cDNA was created to encode, from the amino to the carboxyl termini: a mitochondrial pre-sequence and 6 amino acids of the mature cytochrome c oxidase protein; a few linker amino acids; and GFP. This construct expressed GFP which was imported into the mitochondria.

The use of humanized GFP will be an improvement in the type of studies described by Rizzuto *et al.* (1995), in which one simply desires to label the mitochondria as a whole. Humanized GFP may also be used to confirm that a selected protein has been imported into the mitochondria following expression of a construct in which a desired protein is fused to GFP and a mitochondrial targeting sequence. Here, the mitochondrial targeting sequence should be positioned at the N-terminal of the fusion protein (at the 3' end of the encoding nucleic acid).

## 7. Gene Therapy Applications

Successful gene therapy generally requires the integration of a gene able to correct the genetic disorder into the host genome, where it would co-exist and replicate with the host DNA and be expressed at a level to compensate for the defective gene. Ideally, the disease would be cured by one or a few treatments, with no serious side effects. There have been several approaches to gene therapy proposed

to date, each of which may benefit from combination with the humanized *gfp* of the present invention.

One approach is to transfect DNA containing the gene of interest into cells, e.g., by permeabilizing the cell membrane either chemically or physically. This approach is generally limited to cells that can be temporarily removed from the body and can tolerate the cytotoxicity of the treatment (i.e. lymphocytes). Calcium phosphate precipitation (Graham and Van Der Eb, 1973; Rippe *et al.*, 1990), DEAE-dextran (Gopal, 1985), electroporation (Tur-Kaspa *et al.*, 1986; Potter *et al.*, 1984) and direct microinjection are examples of such methods.

Liposomes or protein conjugates formed with certain lipids and amphophilic peptides can be used for *in vivo* and *in vitro* transfection (Stewart *et al.*, 1992; Torchilin *et al.*, 1992; Zhu *et al.*, 1993; Ledley *et al.*, 1987; Nicolau *et al.*, 1983; Nicolau and Sene, 1982) and DNA coupled to a polylysine-glycoprotein carrier complex may also be used.

The efficiency of gene integration in this manner is generally very low. It is estimated that the gene of interest integrates into the genome of only one cell in 1,000 to 100,000. In the absence of integration, expression of the transfected gene is limited to several days in proliferating cells or several weeks in non proliferating cells due to the degradation of the non-integrated DNAs. This invention may be used to readily identify cells that express the desired transfected gene for longer times.

Jiao *et al.* (1993) describe the success of particle bombardment-mediated gene transfer protocols for transferring and expressing genes in brain tissues, suggesting that this can be employed as an effective method for gene transfer into such tissues.

Plasmids may be used to directly transfer humanized *gfp* genetic material into a cell (Wolfe *et al.*, 1990). DNA segments themselves can therefore be used as delivery agents. The technology for using DNA segments has recently been developed and is generally termed "DNA Vaccination" (Cohen, 1993). It is now known that cells can take up naked DNA and express encoded proteins.

The utilization of this technology, and variations thereof, such as those described by Ulmer *et al.* (1993); Tang *et al.* (1992), Cox *et al.* (1993), Fynan *et al.* (1993), Wang *et al.* (1993) and Whitton *et al.* (1993), each incorporated herein by reference, may be used to deliver DNA to target cells. Parenteral, mucosal and gene-  
5 gun inoculations (Fynan *et al.*, 1993) may be used.

Another approach that may be used capitalizes on the natural ability of viruses to enter cells, bringing their own genetic material with them. Retroviruses have promise as gene delivery vectors due to their ability to integrate their genes into the host genome, transferring a large amount of foreign genetic material, infecting a broad  
10 spectrum of species and cell types and of being packaged in special cell-lines (Miller, 1992).

A variety of retroviral vectors may be used, e.g., herpes simplex virus (U.S. Patent 5,288,641, incorporated herein by reference), cytomegalovirus, and the like, as described by Miller (Miller, 1992). A herpes simplex-thymidine kinase (HS-tK) gene  
15 has been delivered to brain tumors using a retroviral vector system, where it successfully induced susceptibility to the antiviral agent ganciclovir (Culver, *et al.*, 1992).

Gene delivery using second generation retroviral vectors has also been reported. Kasahara *et al.* (1994) prepared an engineered variant of the Moloney murine leukemia virus, that normally infects only mouse cells, and modified an  
20 envelope protein so that the virus specifically bound to, and infected, human cells bearing the erythropoietin (EPO) receptor. This was achieved by inserting a portion of the EPO sequence into an envelope protein to create a chimeric protein with a new binding specificity.

25 Delivery systems such as described above may be used in connection with the present invention. In the context of retroviral treatment, the invention would be used both in the pre-clinical development phase and, also, to monitor gene expression following administration *in vivo*.



Further methods use other viruses, such as vaccinia virus (Ridgeway, 1988; Baichwal and Sugden, 1986; Coupar *et al.*, 1988); defective hepatitis B viruses (Horwich *et al.*, 1990; Chang *et al.*, 1991); adenovirus and adeno-associated virus (AAV; Muzyczka, 1992; see below), which are engineered to serve as vectors for gene transfer. Although some viruses that can accept foreign genetic material are limited in the number of nucleotides they can accommodate and in the range of cells they infect, these viruses have been demonstrated to successfully effect gene expression. Adenoviruses do not integrate their genetic material into the host genome and therefore do not require host replication for gene expression, making them suitable for rapid, efficient, heterologous gene expression. Adenoviruses and AAV (U.S. Patent 5,139,941, incorporated herein by reference) are described herein below. Again, the invention would be used in pre-clinical development and during treatment.

The present discoveries may be utilized in conjunction with certain techniques that are well-known in the biological arts and that are further described in the following sections.

## 8. Biological Functional Equivalents

As mentioned earlier, modification and changes may be made in the structure of GFP and still obtain a molecule having like or otherwise desirable characteristics. For example, certain amino acids may be substituted for other amino acids in a protein structure without appreciable loss of function. It is thus contemplated that various changes may be made in the sequence of humanized *gfp* proteins, by virtue of changing the underlying DNA, without appreciable loss of their biological utility or activity.

It is also well understood by the skilled artisan that inherent in the definition of a biologically functional equivalent protein is the concept that there is a limit to the number of changes that may be made within a defined portion of the molecule and still result in a molecule with an acceptable level of equivalent biological activity. For

example, it has already been explained that substantially truncated *gfp* genes are not biologically functional equivalents.

However, in the context of the present invention, it will also be appreciated that so long as a mutation or change does not result in a GFP protein that has complete loss of fluorescence, the resultant protein will be considered a biologically functional equivalent for the purposes of the invention. Indeed, amino acid replacements that yield proteins with different spectral properties fall within the scope of the invention. This includes mutations within and outside the chromophore region.

### 9. Site-Specific Mutagenesis

Site-specific mutagenesis may be used to prepare further variants of humanized *gfp* genes. Site-specific mutagenesis is a technique useful in the preparation of individual peptides, or biologically functional equivalent proteins or peptides, through specific mutagenesis of the underlying DNA. The technique further provides a ready ability to prepare and test sequence variants by introducing one or more nucleotide sequence changes into the DNA.

Site-specific mutagenesis allows the production of mutants through the use of specific oligonucleotide sequences which encode the DNA sequence of the desired mutation, as well as a sufficient number of adjacent nucleotides, to provide a primer sequence of sufficient size and sequence complexity to form a stable duplex on both sides of the deletion junction being traversed. Typically, a primer of about 17 to 25 nucleotides in length is preferred, with about 5 to 10 residues on both sides of the junction of the sequence being altered.

The technique of site-specific mutagenesis is generally well known in the art as exemplified by publications (Adelman *et al.*, 1983). As will be appreciated, the technique typically employs a phage vector which exists in both a single stranded and double stranded form. Typical vectors useful in site-directed mutagenesis include vectors such as the M13 phage (Messing *et al.*, 1981). These phage are readily commercially available and their use is generally well known to those skilled in the

art. Double stranded plasmids are also routinely employed in site directed mutagenesis which eliminates the step of transferring the gene of interest from a plasmid to a phage.

5 In general, site-directed mutagenesis in accordance herewith is performed by first obtaining a single-stranded vector or melting apart the two strands of a double stranded vector which includes within its sequence a DNA sequence which encodes *gfp* or humanized *gfp*. An oligonucleotide primer bearing the desired mutated sequence is prepared, generally synthetically, for example by the method of Crea *et al.* (1978). This primer is then annealed with the single-stranded vector, and subjected to 10 DNA polymerizing enzymes such as *E. coli* polymerase I Klenow fragment, in order to complete the synthesis of the mutation-bearing strand. Thus, a heteroduplex is formed wherein one strand encodes the original non-mutated sequence and the second strand bears the desired mutation. This heteroduplex vector is then used to transform appropriate cells, such as *E. coli* cells, and clones are selected which include 15 recombinant vectors bearing the mutated sequence arrangement.

Suitable techniques are also described in U.S. Patent 4,888,286, incorporated herein by reference.

20 The preparation of sequence variants of the selected humanized *gfp* gene using site-directed mutagenesis is provided as a means of producing potentially useful GFP species and is not meant to be limiting as there are other ways in which sequence variants of GFP may be obtained. For example, recombinant vectors encoding the desired humanized *gfp* gene may be treated with mutagenic agents to obtain sequence variants (see, *e.g.*, a method described by Eichenlaub, 1979) for the mutagenesis of plasmid DNA using hydroxylamine.

25 Although the foregoing methods are suitable for use in mutagenesis, the use of the polymerase chain reaction (PCR™) is generally now preferred. This technology offers a quick and efficient method for introducing desired mutations into a given DNA sequence. The following text particularly describes the use of PCR™ to

introduce point mutations into a sequence, as may be used to change the amino acid encoded by the given sequence. Adaptations of this method are also suitable for introducing restriction enzyme sites into a DNA molecule.

In this method, synthetic oligonucleotides are designed to incorporate a point mutation at one end of an amplified segment. Following PCR™, the amplified fragments are blunt-ended by treating with Klenow fragments, and the blunt-ended fragments are then ligated and subcloned into a vector to facilitate sequence analysis.

To prepare the template DNA that one desires to mutagenize, the DNA is subcloned into a high copy number vector, such as pUC19, using restriction sites flanking the area to be mutated. Template DNA is then prepared using a plasmid miniprep. Appropriate oligonucleotide primers that are based upon the parent sequence, but which contain the desired point mutation and which are flanked at the 5' end by a restriction enzyme site, are synthesized using an automated synthesizer. It is generally required that the primer be homologous to the template DNA for about 15 bases or so. Primers may be purified by denaturing polyacrylamide gel electrophoresis, although this is not absolutely necessary for use in PCR™. The 5' end of the oligonucleotides should then be phosphorylated.

The template DNA should be amplified by PCR™, using the oligonucleotide primers that contain the desired point mutations. The concentration of MgCl<sub>2</sub> in the amplification buffer will generally be about 15 mM. Generally about 20-25 cycles of PCR™ should be carried out as follows: denaturation, 35 sec. at 95°C; hybridization, 2 min. at 50°C; and extension, 2 min. at 72°C. The PCR™ will generally include a last cycle extension of about 10 min. at 72°C. After the final extension step, about 5 units of Klenow fragments should be added to the reaction mixture and incubated for a further 15 min. at about 30°C. The exonuclease activity of the Klenow fragments is required to make the ends flush and suitable for blunt-end cloning.

The resultant reaction mixture should generally be analyzed by nondenaturing agarose or acrylamide gel electrophoresis to verify that the amplification has yielded

the predicted product. One would then process the reaction mixture by removing most of the mineral oils, extracting with chloroform to remove the remaining oil, extracting with buffered phenol and then concentrating by precipitation with 100% ethanol. Next, one should digest about half of the amplified fragments with a  
5 restriction enzyme that cuts at the flanking sequences used in the oligonucleotides. The digested fragments are purified on a low gelling/melting agarose gel.

To subclone the fragments and to check the point mutation, one would subclone the two amplified fragments into an appropriately digested vector by blunt-end ligation. This would be used to transform *E. coli*, from which plasmid DNA  
10 could subsequently be prepared using a miniprep. The amplified portion of the plasmid DNA would then be analyzed by DNA sequencing to confirm that the correct point mutation was generated. This is important as Taq DNA polymerase can introduce additional mutations into DNA fragments.

The introduction of a point mutation can also be effected using sequential  
15 PCR™ steps. In this procedure, the two fragments encompassing the mutation are annealed with each other and extended by mutually primed synthesis. This fragment is then amplified by a second PCR™ step, thereby avoiding the blunt-end ligation required in the above protocol. In this method, the preparation of the template DNA, the generation of the oligonucleotide primers and the first PCR™ amplification are  
20 performed as described above. In this process, however, the chosen oligonucleotides should be homologous to the template DNA for a stretch of between about 15 and about 20 bases and must also overlap with each other by about 10 bases or more.

In the second PCR™ amplification, one would use each amplified fragment and each flanking sequence primer and carry PCR™ for between about 20 and about  
25 cycles, using the conditions as described above. One would again subclone the fragments and check that the point mutation was correct by using the steps outlined above.

In using either of the foregoing methods, it is generally preferred to introduce the mutation by amplifying as small a fragment as possible. Of course, parameters such as the melting temperature of the oligonucleotide, as will generally be influenced by the GC content and the length of the oligo, should also be carefully considered.

5 The execution of these methods, and their optimization if necessary, will be known to those of skill in the art, and are further described in various publications, such as *Current Protocols in Molecular Biology, 1995*, incorporated herein by reference.

#### 10. Expression Plasmids and Vectors

A wide variety of recombinant plasmids and vectors may be engineered to  
10 expresses a humanized *gfp* genes and so used to deliver GFP to a cell.

As used herein, the term "expression vector" includes any type of genetic construct containing a nucleic acid sequence of a humanized *gfp* gene in which the nucleic acid sequence is capable of being transcribed in a mammalian or human cell. The expression vectors of the invention should also direct translation into GFP  
15 protein, as provided by the invention itself. In addition to the humanized *gfp* sequence, expression vectors will generally include restriction enzyme cleavage sites and the other initial, terminal and intermediate DNA sequences that are usually employed in vectors to facilitate their construction and use.

Expression vectors for use in mammalian cells ordinarily include an origin of  
20 replication (as necessary) and a promoter located in front of the gene to be expressed. A polyadenylation site and transcriptional terminator sequences are preferably included. Ribosome binding sites and RNA splice sites may also be included. An example is the SV40 late gene 16S/19S splice donor/splice acceptor signal.

The origin of replication may be provided either by construction of the vector  
25 to include an exogenous origin, such as may be derived from SV40 or other viral (*e.g.*, Polyoma, Adeno, VSV, BPV) source, or may be provided by the host cell chromosomal replication mechanism. If the vector is integrated into the host cell chromosome, the latter is often sufficient. Promoters are discussed below.

Specific initiation signals may also be required for efficient translation. These signals include the ATG initiation codon and adjacent sequences. Exogenous translational control signals, including the ATG initiation codon, may additionally need to be provided. One of ordinary skill in the art would readily be capable of determining this and providing the necessary signals. It is well known that the initiation codon must be in-frame (or in-phase) with the reading frame of the desired coding sequence to ensure translation of the entire insert. These exogenous translational control signals and initiation codons can be of a variety of origins, both natural and synthetic. The efficiency of expression may be enhanced by the inclusion of appropriate transcription elements and transcription terminators (Bittner *et al.*, 1987).

In mammalian expression, one will also typically desire to incorporate into the transcriptional unit an appropriate polyadenylation site (e.g., 5'-AATAAA-3') if one was not contained within the original cloned segment. Typically, the poly A addition site is placed about 30 to 2000 nucleotides "downstream" of the termination site of the protein at a position prior to transcription termination. The nature of the polyadenylation signal is not believed to be crucial to the successful practice of the invention, and any such sequence may be employed. SV40, bovine growth hormone gene and signals are convenient and known to function well.

For long-term, high-yield production of recombinant proteins, stable expression is often preferred. Here, rather than using expression vectors that contain viral origins of replication, host cells can be transformed with vectors controlled by appropriate expression control elements (e.g., promoter, enhancer, sequences, transcription terminators, polyadenylation sites, etc.), and a selectable marker. The combined use of humanized *gfp* sequences and selectable markers is therefore also contemplated.

In stable expression, following the introduction of foreign DNA, engineered cells may be allowed to grow for 1-2 days in an enriched media, and then are switched to a selective media. The selectable marker in the recombinant plasmid confers

resistance to the selection and allows cells to stably integrate the plasmid into their chromosomes and grow to form foci which in turn can be cloned and expanded into cell lines.

5 A number of selection systems may be used, including, but not limited, to the herpes simplex virus thymidine kinase (Wigler *et al.*, 1977), hypoxanthine-guanine phosphoribosyltransferase (Szybalska *et al.*, 1962) and adenine phosphoribosyltransferase genes (Lowy *et al.*, 1980), in tk-, hgp<sup>rt</sup>- or aprt- cells, respectively. Also, antimetabolite resistance can be used as the basis of selection for dhfr, that confers resistance to methotrexate (Wigler *et al.*, 1980; O'Hare *et al.*, 1981); 10 gpt, that confers resistance to mycophenolic acid (Mulligan *et al.*, 1981); *neo*, that confers resistance to the aminoglycoside G-418 (Colberre-Garapin *et al.*, 1981); and hyg<sup>r</sup>, that confers resistance to hygromycin (Santerre *et al.*, 1984).

It is also contemplated that preferred vectors will include an origin of replication functional in bacteria and a typical antibiotic resistance gene, allowing 15 propagation and selection, respectively, in transformed bacterial cells.

In preferred vectors, multiple cloning sites (MCSs) will also be provided at the ends of the GFP coding sequence to facilitate the creation of GFP fusion proteins. The MCS should be present in three different reading frames allowing in-frame fusions to be generated with a convenient restriction site in the gene of interest.

20 Coordinate expression of different genes from the same promoter in a recombinant vector may be achieved by using an IRES element, such as the internal ribosomal entry site of Poliovirus type 1 from pSBC-1 (Dirks *et al.*, 1993), as described below.

## 11. Promoters

25 Expression vectors comprises protein-encoding nucleic acid segments under the control of one or more promoters. To bring a coding sequence "under the control of" a promoter, one positions the 5' end of the transcription initiation site of the



transcriptional reading frame generally between about 1 and about 50 nucleotides "downstream" of (i.e., 3' of) the chosen promoter. The "upstream" promoter stimulates transcription of the DNA and promotes expression of the encoded recombinant protein.

5           A "promoter" refers to a DNA sequence recognized by the synthetic machinery of a cell, or introduced synthetic machinery, required to initiate the specific transcription of a gene. As used herein, the promoter should be operable in mammalian and human cells. The phrases "operable" and "exerting transcriptional control" mean that the promoter is in the correct location and orientation in relation to  
10           the humanized *gfp* nucleic acid to control RNA polymerase initiation and expression of the humanized gene.

          The promoter used to express the humanized GFP is not critical to the present invention. In the examples given, the human cytomegalovirus (CMV) immediate  
15           early gene promoter has been used (Thomsen *et. al.*, 1984), which results in the constitutive, high-level expression of the foreign gene. However, the use of other viral or mammalian cellular promoters which are well-known in the art is also suitable to achieve expression of the humanized *gfp* gene.

          A number of viral based expression systems may be utilized, for example, commonly used promoters are derived from polyoma, Adenovirus 2, and Simian  
20           Virus 40 (SV40). The early and late promoters of SV40 virus are particularly useful because both are obtained easily from the virus as a fragment which also contains the SV40 viral origin of replication. Smaller or larger SV40 fragments may also be used, as may the Rous sarcoma virus (RSV) long terminal repeat (LTR).

          By employing a promoter with well-known properties, the level and pattern of  
25           expression of humanized GFP can be optimized. For example, selection of a promoter which is active specifically in certain cell types will permit tissue-specific expression. Such promoters include those such as the liver fatty acid binding (FAB) protein gene promoter, specific for colon epithelial cells; the insulin gene promoter,

specific for pancreatic cells; the transphyretin,  $\alpha$ 1-antitrypsin, plasminogen activator inhibitor type 1 (PAI-1), apolipoprotein AI and LDL receptor gene promoters, each directing specific or preferential expression in liver cells. Promoters active in brain tissues include the myelin basic protein (MBP) gene promoter, specific for  
5 oligodendrocytes; the glial fibrillary acidic protein (GFAP) gene promoter, specific for glial cells; and the neural-specific enolase (NSE) promoter that is specific for nerve cells.

Furthermore, selection of a promoter that is regulated in response to specific chemical or physiological signals can permit inducible expression of the humanized  
10 *gfp* gene. Examples of suitable inducible promoters include the PAI-1, cytochrome P450 gene promoters, heat shock protein genes and hormone inducible gene promoters, and the *fos* and *jun* promoters inducible by ionizing radiation.

As mentioned above, inducible promoters are useful *in vivo*, e.g., in gene therapy, and *in vitro*, in screening assays. In screening for the presence of a particular  
15 compound within a composition, useful groups of inducible promoters are those activated by heavy metals (Freedman *et al.*, 1993); cytochrome P450 gene promoters, activated by a range of toxic compounds; heat shock protein gene promoters (Stringham *et al.*, 1992; Welch, 1993), such as the hsp70 promoter, which are stimulated by various stresses to name a few examples.

## 20 12. IRES

Internal ribosome binding sites (IRES) elements are used to create multigenic or polycistronic messages. IRES elements are able to bypass the ribosome scanning mechanism of 5' methylated Cap dependent translation and begin translation at internal sites (Pelletier and Sonenberg, 1988). IRES elements from two members of  
25 the picornavirus family (polio and encephalomyocarditis) have been described (Pelletier and Sonenberg, 1988), as well an IRES from a mammalian message (Macejak and Sarnow, 1991). Any of the foregoing may be used in a humanized *gfp* vector in accordance with the present invention.

IRES elements can be linked to heterologous open reading frames. Multiple open reading frames can be transcribed together, each separated by an IRES, creating polycistronic messages. By virtue of the IRES element, each open reading frame is accessible to ribosomes for efficient translation. In this manner, multiple genes, one of which will be a humanized *gfp* gene, can be efficiently expressed using a single promoter/ enhancer to transcribe a single message.

Any heterologous open reading frame can be linked to IRES elements. In the present context, this means any selected protein that one desires to express and any second reporter gene (or selectable marker gene). Even the expression of multiple proteins could be achieved, with concurrent monitoring through GFP production.

### 13. AAV Vectors

Adeno-associated virus(AAV) is an attractive vector system for human gene therapy because it is non-pathogenic for humans, it has a high frequency of integration, and it can infect nondividing cells, thus making it useful for delivery of genes into mammalian cells both in tissue culture and in whole animals (Muzyczka, 1992). Recent studies have demonstrated AAV to be a potentially good vector for gene delivery (LaFace, *et al.* 1988; Zhou, *et al.*, 1993; Flotte, *et al.*, 1993; Walsh, *et al.*, 1994). Recombinant AAV vectors have been used successfully for *in vitro* and *in vivo* transduction of marker genes (Kaplitt, *et al.*, 1994; Lebkowski, *et al.*, 1988; Samulski, *et al.*, 1989; Shelling and Smith, 1994; Yoder, *et al.*, 1994; Zhou, *et al.*, 1994; Hermonat and Muzyczka, 1984; Tratschin, *et al.*, 1985; McLaughlin, *et al.*, 1988) and genes involved in human diseases (Flotte, *et al.*, 1992; Luo, *et al.*, 1994; Ohi, *et al.*, 1990; Walsh, *et al.*, 1992; Wei, *et al.*, 1994). Recently, an AAV vector has been approved for phase I human trials for the treatment of cystic fibrosis.

AAV is a dependent parvovirus in that it requires coinfection with another virus (either adenovirus or a member of the herpes virus family) to undergo a productive infection in cultured cells (Muzyczka, 1992). In the absence of coinfection with helper virus, the wild type AAV genome integrates through its ends into human

chromosome 19 where it resides in a latent state as a provirus (Kotin *et al.*, 1990; Samulski *et al.*, 1991). rAAV, however, is not restricted to chromosome 19 for integration unless the AAV Rep protein is also expressed (Shelling and Smith, 1994). When a cell carrying an AAV provirus is superinfected with a helper virus, the AAV genome is "rescued: from the chromosome or from a recombinant plasmid, and a normal productive infection is established (Samulski, *et al.*, 1983; McLaughlin, *et al.*, 1988; Berns, 1990, Kotin, *et al.*, 1990; Muzyczka, 1992). AAV has a broad host range for infectivity (Tratschin, *et al.*, 1984; Laughlin, *et al.*, 1986; Lebkowski, *et al.*, 1988; McLaughlin, *et al.*, 1988).

Typically, recombinant AAV (rAAV) virus is made by cotransfecting a plasmid containing the gene of interest flanked by the two AAV terminal repeats (see Fig.2B for example, and McLaughlin *et al.*, 1988; Samulski *et al.*, 1989) and an expression plasmid containing the wild type AAV coding sequences without the terminal repeats, for example pIM45 (McCarty *et al.*, 1991). The cells are also infected or transfected with adenovirus or plasmids carrying the adenovirus genes required for AAV helper function. rAAV virus stocks made in such fashion are contaminated with adenovirus which must be physically separated from the rAAV particles (for example, by cesium chloride density centrifugation). Alternatively, adenovirus vectors containing the AAV coding regions or cell lines containing the AAV coding regions and some or all of the adenovirus helper genes could be used (Yang *et al.*, 1994; Clark *et al.*, 1995). Cell lines carrying the rAAV DNA as an integrated provirus can also be used (Flotte *et al.*, 1995).

rAAV vectors are described in U.S. Patent Nos. 5,139,941 and 4,797,368, each incorporated herein by reference.

#### 14. Adenovirus Vectors

Adenovirus vectors, and preferably replication defective vectors, may be used in the context of the present invention. For example, as achieved through the deletion of the viral early region 1 (E1A) region such that the virus is competent to replicate

only in cells, such as human 293 cells, which express adenovirus early region 1 genes from their cellular genome. This is important because the virus will therefore not kill normal cells that do not express early gene products. Techniques for preparing replication defective adenoviruses are well known in the art, as exemplified by Ghosh-Choudhury and Graham (1987); McGrory *et. al.* (1988); and Gluzman *et. al.* (1982).  
5 Rosenfeld *et. al.* (1991; 1992) and Stratford-Perricaudet *et. al.* (1990; 1992) also describe uses of adenovirus.

Other than the requirement that the adenovirus vector be replication defective, the nature of the adenovirus vector is not believed to be crucial. The adenovirus may  
10 be of any of the 42 different known serotypes or subgroups A-F. Adenovirus type 5 of subgroup C is the preferred starting material in order to obtain the conditional replication-defective adenovirus vector for use in the method of the present invention. This is because Adenovirus type 5 is a human adenovirus about which a great deal of biochemical and genetic information is known, it has historically been used for most  
15 constructions employing adenovirus as a vector, and it is non-oncogenic.

In that the vectors for use in these aspects are replication defective, they will typically not have an adenovirus E1 region. Thus, it will be most convenient to introduce the humanized *gfp* gene at the position from which the E1 coding sequences have been removed. However, the position of insertion of the humanized gene within  
20 the adenovirus sequences is not critical. The humanized transcriptional unit may also be inserted in lieu of the deleted E3 region in E3 replacement vectors as described previously by Karlsson *et. al.* (1986).

### 15. Expression Kits

Expression kits comprising humanized *gfp* genes form another aspect of the  
25 invention. Such kits will generally contain, in suitable container means, a formulation of a humanized *gfp* gene or a vector capable of expressing a humanized *gfp* gene. The gene or vector may be provided in a pharmaceutically acceptable formulation.

When the components of the kit are provided in one or more liquid solutions, the liquid solution is an aqueous solution, with a sterile aqueous solution being particularly preferred. The humanized *gfp* gene or vector may also be formulated into a syringeable composition. In which case, the container means may itself be a syringe, pipette, eye dropper, or other such like apparatus, from which the formulation may be applied to a cell, or to an area of the body, or injected into an animal, or applied to and mixed with other components of a kit.

However, the components of the kit may be provided as dried powder(s). When reagents or components are provided as a dry powder, the powder can be reconstituted by the addition of a suitable solvent. It is envisioned that the solvent may also be provided in another container means.

The container means will generally include at least one vial, test tube, flask, bottle, syringe or other container means, into which the humanized *gfp* gene or vector may be placed, preferably, suitably allocated. A second humanized *gfp* gene or vector construct may also be provided, wherein the kit will also generally contain a second vial or other container into which this is be placed. The kits may also comprise a second/third container means for containing a sterile, pharmaceutically acceptable buffer or other diluent.

The kits of the present invention will also typically include a means for containing the vials in close confinement for commercial sale, such as, e.g., injection or blow-molded plastic containers into which the desired vials are retained.

Irrespective of the number or type of containers, the kits of the invention may also comprise, or be packaged with, one or more further molecular biological reagents, such as restriction enzymes.

## 16. Recombinant Expression

Desired clones may be incorporated into an expression system with humanized *gfp* for recombinant expression. It is believed that virtually any eukaryotic expression

system may be employed in this manner. Transformation of host cells with DNA segments encoding a selected protein and humanized *gfp* will provide a convenient means of monitoring expression. Both cDNA and genomic sequences are suitable for eukaryotic expression, as the host cell will generally process the genomic transcripts to yield functional mRNA for translation into protein.

Generally speaking, it may be more convenient to employ as the recombinant gene a cDNA version of the gene. It is believed that the use of a cDNA version will provide advantages in that the size of the gene will generally be much smaller and more readily employed to transfect the targeted cell than will a genomic gene, which will typically be up to an order of magnitude larger than the cDNA gene. However, the possibility of employing genomic versions of particular genes is not excluded.

As noted above, it is proposed that different proteins may be co-expressed and monitored in the same cell using different colored humanized GFPs. This may be achieved by co-transfecting the cell with two distinct recombinant vectors, each bearing a copy of the humanized *gfp* linked to a particular protein-encoding DNA. Alternatively, a single recombinant vector may be constructed to include both such coding regions which could then be expressed in cells transfected with the single vector.

#### 17. Recombinant Host Cells

The terms "engineered" and "recombinant" cells are intended to refer to a cell into which an exogenous DNA segment or gene that includes a humanized *gfp* gene sequence has been introduced. Therefore, engineered cells are distinguishable from naturally occurring cells which do not contain a recombinantly introduced exogenous DNA segment or gene. Engineered cells are thus cells having a gene or genes introduced through the hand of man.

Established cell lines that grow continuously in culture form one group of cells that may be used in connection with the present invention. Examples of such mammalian host cell lines that are particularly contemplated for use are VERO cells,

HeLa cells, Chinese hamster ovary (CHO) cell lines, COS cells, such as COS-7, W138, BHK, HepG2, 3T3, RIN, MDCK, A549, PC12, K562 and 293 cells.

Primary cell lines are also contemplated for use with this invention. Primary cell lines are those cells that have been removed from an animal or human subject and are capable of surviving in culture for a limited period of time. Such cells are often manipulated, e.g., to introduce a beneficial gene, and then re-introduced into the animal from which they were originally obtained. This technique is often termed *ex vivo* gene therapy.

Primary cells of all vertebrate species are considered for use with the humanized *gfp* genes disclosed herein, whether or not they are returned to the body of an animal. These include, by way of example only, bone marrow cells, nerve cells, lung epithelial cells and hepatocytes.

Humanized *gfp*-containing cells within the body that have been previously engineered to express, secrete or otherwise deliver therapeutic or desired agents to an animal or human subject are also encompassed within the cells of the invention, whether or not they were originally derived from the animal. Cells that were not so-obtained from the ultimate host animal may be cells from an immunologically compatible animal, cells that have been immunologically modified or disabled, cells that are protected within a semi-permeable device in the host animal and even largely unmodified cells that are intended to have a temporary life span within the host animal.

Of course, it will be understood that as the present invention is well suited for use in more direct gene therapy methods, any target cell of the body can contain a humanized *gfp* gene as described in this invention. All such cells are considered to fall within the description of a "recombinant host cell", as used herein. This includes any cell within an animal or human subject that comprises one or more copies of a humanized *gfp* gene or vector, irrespective of the manner in which the cell acquires



the gene, e.g., by transfection, infection and the like. Diseased cells, deficient cells and healthy cells are all encompassed within the invention in this manner.

#### 18. Cloning other *gfp* Genes

It is also contemplated that *gfp* genes from other organisms may be cloned. These may have improved or otherwise desirable spectral properties and may be then be humanized in accordance with the present invention.

Cloning a DNA molecule encoding a GFP-like protein from another organism would simply require screening a DNA library to obtain a specific DNA molecule and purify it to render it distinct from other portions of DNA. The first step in such cloning procedures is the screening of an appropriate DNA library. The screening procedure may be an expression screening protocol, e.g., employing antibodies directed against the GFP protein, or activity assays based upon fluorescence.

Alternatively, screening may be based on the hybridization of oligonucleotide probes, designed from a consideration of portions of the known *gfp* DNA sequences. The operation of such screening protocols are well known to those of skill in the art and are described in detail in the scientific literature, for example, in Sambrook *et al.* (1989), incorporated herein by reference.

The following examples are included to demonstrate preferred embodiments of the invention. It should be appreciated by those of skill in the art that the techniques disclosed in the examples that follow represent techniques discovered by the inventors to function well in the practice of the invention, and thus can be considered to constitute preferred modes for its practice. However, those of skill in the art should, in light of the present disclosure, appreciate that many changes can be made in the specific embodiments that are disclosed and still obtain a like or similar result without departing from the spirit and scope of the invention.

## EXAMPLE I

Low Expression of Jellyfish GFP in 293 Cells

This example describes attempts to use recombinant AAV (rAAV) that expresses a jellyfish *gfp10* reporter gene in transfection and expression in 293 cells.

5 **Generation of AAV vectors and rAAV expressing wild type *gfp***

Adeno-associated virus (AAV) is now widely used as a vector to deliver genes into different cell types. There are many advantages of using AAV including the apparent absence of pathogenicity, high viability of virion, site-specific integration, long-term expression of the delivered gene and relative independence of infectivity from host chromosome replication and cell cycling.

10

One disadvantage of AAV is a limiting packaging size of the viral DNA, which can not exceed 5,000 nucleotides. Most AAV vectors currently available carry one or another reporter genes, namely *E. coli*  $\beta$ -galactosidase and neomycin phosphotransferase. Both of these reporter genes are quite bulky and occupy too much of the limited space of the AAV genome. Detection protocols for these gene products are clumsy and cumbersome.

15

This section describes the construction of a recombinant AAV vector plasmid, pTR<sub>BS</sub>-UF (FIG. 2A), which carried both the jellyfish *gfp10* gene and *neoR* gene. The plasmid TU#65 (Ward *et al.*, 1994) was used as the source of the *gfp10* coding sequence and the gene was placed under the control of the immediate early CMV promoter. A schematic diagram of vector generation is shown in FIG. 2B.

20

Briefly, the *gfp10* sequence was subcloned into the *NotI* site of pCMV $\beta$  (Clontech) after digesting the parent plasmid TU#65 (Chalfie *et al.*, 1994) with *AgeI* and *EcoRI*, filling in the ends with Klenow fragment and adding *NotI*-linkers. The resulting plasmid, designated pCMVgreen was then used as a template to amplify in a

25

PCR reaction the transcription cassette containing the CMV promoter, the SV40 intron, the *gfp10* cDNA and the SV40 polyadenylation signal.

The upstream PCR primer complementary to the CMV promoter, also included an overhang that contained the *Bgl*II, *Eco*RI, and *Kpn*I sites. The downstream PCR primer, complementary to the polyadenylation signal, included a *Sal*I site overhang. The polyadenylation signal of the bovine growth hormone (bGH) gene was amplified in another PCR reaction using the plasmid pRc/CMV (Invitrogen) as the template. The upstream primer in this reaction contained a *Sal*I site sequence overhang and the downstream primer contained a *Bgl*II site.

After purification of the PCR products on a 1% agarose gel, the respective fragments were digested with *Sal*I and ligated to each other via the exposed *Sal*I ends. The ligation product was gel purified and digested with *Bgl*II. The 160 bp *Bgl*II-*Pst*I fragment, containing the AAV terminal repeat, was isolated by gel purification from the plasmid pTRBR(+) (Ryan *et al.*, 1995). This fragment had been subcloned into pTR<sub>BR</sub>(+) from the previously described plasmid *dl3-94* (McLaughlin *et al.*, 1988). It was then ligated to both ends of the *Bgl*II-digested cassette, containing the CMV promoter, SV40 intron, *gfp10* cDNA, SV40 poly(A) and bPH poly(A).

The ligation product was then cut with *Pst*I and subcloned into plasmid pBS(+) (Stratagene), which had been modified by converting the *Pvu*II sites at 766 and 1148 into *Pst*I sites by adding *Pst*I-linkers and deleting the internal 382 bp fragment, containing the polylinker region. The resulting plasmid was designated pTRgreen.

The neo-resistance gene cassette, driven by the HSV thymidine kinase gene promoter and the enhancer from polyoma virus was obtained from the plasmid pMC1neo (Stratagene) by cutting the plasmid with *Xho*I, filling in the end with Klenow, adding *Sal*I-linkers, and by digesting with *Sal*I. The DNA fragment containing the *neo* cassette was gel purified and subcloned into the *Sal*I site of

pTRgreen, digested with *Sa*II. The resulting construct, pTR<sub>BS</sub>-UF is shown in FIG. 2A.

To generate recombinant AAV (rAAV) virus, 293 cells were co-transfected with pTR<sub>BS</sub>-UF and the helper plasmid pIM45, carrying the wt AAV genome without terminal repeats (McCarty *et al.*, 1991). The same cells were also infected with  
5 adenovirus at a multiplicity of infection (m.o.i.) of 10.

Recombinant AAV was harvested after 60 h by freezing and thawing cells three times, heat-inactivating Ad for 30 min. at 56°C, spinning down cell debris and purifying the virus through a CsCl gradient (1.40 g/ml) formed in a SW41 rotor for 48  
10 hrs at 200,000 g. The gradient was fractionated and the density was determined by refractometry. Fractions with densities between 1.38 and 1.4 g/cm<sup>3</sup> were pooled and dialyzed against DMEM media for 4 h. The AAV titer was determined by the infectious center assay (McLaughlin *et al.*, 1988).

#### **Low level expression of wild type *gfp***

When pTR<sub>BS</sub>-UF plasmid DNA was transfected into 293 cells, the average  
15 number of cells expressing GFP was usually less than 5% (FIG. 3). Furthermore, 293 cells infected with the recombinant AAV, carrying the same GFP expression cassette, were repeatedly scored as GFP-negative. The only difference between these two studies was apparently the number of GFP cDNAs delivered into each cell. During  
20 the transfection, hundreds or even thousands of plasmid copies are being delivered, whereas infection under conditions of low m.o.i. (less than 1) delivers only a single copy of a gene.

The inventors thus found that the *gfp10* cDNA, as originally described by Chalfie *et al.* (1994), was a poor reporter when expressed in primate and human cells.  
25 Clearly, new techniques were required by which the expression of *gfp10* in mammalian and human cells could be enhanced.

**EXAMPLE II****Attempts to Increase GFP Expression in Human Cells**

The present example describes various methods that could be used in an attempt to increase the expression of *gfp10* in mammalian and human cells.

5           There are several potential ways to boost the amount of desired gene product which is under control of a given promoter. One such method is to try to increase the stability of mRNA by introducing an intron sequence which directs the pre-mRNA into the processing/splicing pathway through the protein/RNA interactions and transport.

10           The GFP expression cassette of the present inventors' contained the sequence of the SV40 late gene 16S/19S splice donor/splice acceptor signal (FIG. 1B). This sequence is often employed in the literature, but its effects can be variable and gene-specific. The inventors thus reasoned that this technique alone would not significantly increase GFP expression in human cells.

15           It is also conceivable to increase the stability of an alien protein by fusing it to another protein or polypeptide domain. In this regard, vectors allowing fusion of the jellyfish sequence to a second coding region are available. However, the inventors did not believe that this would adequately substitute for the defects of the *gfp* sequence.

20           Another possible way to increase the protein yield is to maximize the translation efficiency by introducing sequences that facilitate initiation of translation of eukaryotic mRNA. One such sequence, immediately preceding the AUG initiator codon, is the Kozak consensus sequence (GCC)GCCA/GCCATG (SEQ ID NO:8; Kozak, 1987)). Additionally, an optimally positioned stem-loop hairpin structure, located about 14 nucleotides downstream of the AUG codon, could be used (Kozak,  
25           1990).

          However, studies are known in which a Kozak sequence placed upstream of *gfp10* did not significantly change the expression efficiency. Therefore, despite the

general usefulness of the Kozak sequence, and the specific suggestions of the prior art to use the Kozak sequence in conjunction with *gfp* (see, e.g., PCT application WO 95/07463), introduction of the Kozak sequence upstream of *gfp10* does not appear to have been particularly successful.

5           The inventors reasoned that any increase in initiation that may be afforded by the Kozak sequence would not yield a significant increase in *gfp10* expression as translation would still be limited. This drawback was thought to severely limit the usefulness of the Kozak sequence alone, although it was considered that benefits may result upon combination of the Kozak sequence with another method directed to  
10           addressing the translation efficiency problem.

### EXAMPLE III

#### Design of Humanized GFP

15           In light of the failure of the foregoing well-used techniques to improve GFP expression in mammalian cells, the inventors hypothesized that one of the important reasons for the low expression of GFP in such cells was the poor translation efficiency of the mRNA in the cell environment. The present example describes the design of a humanized GFP for use in obtaining increased GFP expression in mammalian and human cells.

20           Low expression of proteins can result from a poor translation efficiency of an mRNA species in certain cells. For example, the human cell environment is characterized by a particular set of isoacceptor tRNAs, which are different in other species. Indeed, it is generally known that the choice of synonymous codons in both prokaryotic and eukaryotic genes is strongly biased. Also, there exist clear  
25           similarities in codon usage among different genes of the same or taxonomically related organisms, regardless of the functions of the genes or the dissimilarities among the genes (even among those encoding cognate proteins) of taxonomically distant organisms (Grantham *et al.*, 1991; Ikemura, 1980; Ikemura *et al.*, 1981).

The differences in codon-choice patterns between the organisms have been attributed to differences in the actual populations of isoacceptor tRNAs and to differences in modified nucleotides at the anticodon wobble position (Ikemura *et al.*, 1981; Ikemura *et al.*, 1982). The synonymous codon choices do not affect the nature of the protein synthesized but may relate to the expressivity of the gene (Bennetzen and Hall, 1982; Ikemura *et al.*, 1981; Ikemura *et al.*, 1981; Ikemura *et al.*, 1982). The extent of the correlation between codon usage and tRNA content has been found to relate to the production levels of individual genes.

Therefore, the present inventors investigated the codon usage frequencies of the jellyfish *gfp10* and compared it to the average mean of those summed for 1490 human genes (Wada *et al.*, 1990). An analysis of the sequence of *gfp10* cDNA showed that the codon usage frequencies of this jellyfish gene are quite different from those prevalent in the human genome. For example, Leu amino acid residues at the positions 18, 53, 125, 178, 195 and 236; Ser at position 208; and Val at positions 93, 150 and 224 of the jellyfish GFP (SEQ ID NO:2) are encoded by triplets which are almost never used in human genes (codons in SEQ ID NO:1). The rest of the amino acids also display a bias different from human, though not as dramatic.

Therefore, as the inventors reasoned that the mRNA coding for the jellyfish GFP is translated with low efficiency in a human cell system, yielding insufficient amounts of the protein for visual detection of fluorescence, the inventors designed a synthetic version of the jellyfish *gfp10*. In this synthetic, or humanized, version of *gfp10*, codons preferentially used in the human genome were inserted to replace those rare or less frequently used codons present in the original *gfp10*.

## EXAMPLE IV

Construction of Humanized GFP Gene and Vectors

This example describes the production of a humanized GFP for use in increased expression in mammalian and human cells, using the results of the analyses described in Example III.

A total of 92 base substitutions were made in 88 codons without changing the amino acid sequence (FIG. 1). In addition, the sequence immediately preceding the start codon for the GFP protein in pTR<sub>BS</sub>-UF1 was modified to produce a Kozak consensus sequence. Also, codon 80 was reverted back to a wild type glutamine residue (Prasher *et al.*, 1992), as compared to arginine, as described by Chalfie *et al.* (1994). This construct, termed pTR<sub>BS</sub>-UF1, was prepared as follows.

The *gfp* cDNA was synthesized by assembling mutually priming synthetic oligonucleotides (see FIG. 1). The *gfp10* gene was divided into 8 segments of approximately equal length and 4 pairs of oligonucleotides were synthesized, each pair consisting of two overlapping oligos with a short stretch of overlap (FIG. 3, underlined), one coding for the sense strand, the other for the antisense. After annealing and extension with Sequenase, pairs 1 and 2 were digested with *Eae*I, whereas pairs 3 and 4 were digested with *Bam*HI. The digested products were then ligated in two separate reactions: oligos 1 to 2 and oligos 3 to 4. Ligation products of the desired length were purified on a 5% polyacrylamide gel under nondenaturing conditions. Both DNA fragments were then digested with *Eco*RII and ligated to each other.

The final product was amplified in a PCR<sup>TM</sup> reaction, using a pair of oligonucleotides, partially complementary to the humanized *gfp* cDNA (see below, bold type letters) and containing the restriction sites *Not*I, *Xba*I and *Hind*III (see below, underlined) for cloning. The sequence of the upstream primer, which included a Kozak consensus sequence (Kozak, 1987) and that of the downstream primer, respectively, are shown:



5'-TGCTCTAGAGCGGCCCGCCACCATGAGCAAGGGCGAGGAACTG-3'  
(SEQ ID NO:9);

5'-CGGAAGCTTGCGGCCGCTCACTTGTACAGCTCGTCCAT-3' (SEQ ID  
NO:10).

5

10

After digestion of the PCR product with *Xba*I and *Hind*III the DNA fragment was cloned into pBS(+) (Stratagene) and sequenced. Several independent clones were isolated and sequenced. These clones had mutations in the coding sequence which presumably occurred either during PCR amplification or were present in the oligonucleotides. Portions of these clones were then spliced together to produce the final *gfp<sub>h</sub>* gene that contained a wild type amino acid sequence. The resulting constructs was designated pBS-GFP<sub>H1</sub> and contained the coding sequence for wild type GFP.

15

To construct pTR<sub>BS</sub>-UF1, the inventors substituted the *Not*I fragment of pBS-GFP<sub>H1</sub> (wild type) for the *Not*I fragment of pTR<sub>BS</sub>-UF (FIG. 2A).

20

To generate recombinant AAV (rAAV) virus, 293 cells were co-transfected with pTR<sub>BS</sub>-UF1 and the helper plasmid pIM45, carrying the wt AAV genome without terminal repeats (McCarty *et al.*, 1991). The same cells were also infected with adenovirus at a multiplicity of infection (m.o.i.) of 10.

25

Recombinant AAV was harvested after 60 h by freezing and thawing cells three times, heat-inactivating Ad for 30 min. at 56°C, spinning down cell debris and purifying the virus through a CsCl gradient (1.40 g/ml) formed in a SW41 rotor for 48 hrs at 200,000 g. The gradient was fractionated and the density was determined by refractometry. Fractions with densities between 1.38 and 1.4 g/cm<sup>3</sup> were pooled and dialyzed against DMEM media for 4 h. The AAV titer was determined by the infectious center assay (McLaughlin *et al.*, 1988).

**EXAMPLE V****Construction of Humanized GFP Variants and rAAV Vectors**

This example describes the production of a further humanized GFP sequences encoding GFP protein variants with different properties to the wild type protein. The variants also have increased expression in mammalian and human cells.

Two mutants were constructed in the pBS-GFP<sub>h</sub> background by site-directed PCR<sup>™</sup> mutagenesis. A first humanized mutant mirrors the protein sequence reported by Heim *et al.* (1995) who described a Ser65 to Thr65 substitution that increased the fluorescence yield in the context of the original jellyfish codon sequence. Reasoning that this mutation might be even more effective in the context of the humanized pTR<sub>BS</sub>-UF1 sequence, the inventors reproduced this point mutation in the pTR<sub>BS</sub>-UF1 background to produce plasmid pTR<sub>BS</sub>-UF2.

As a further step in providing enhanced fluorescence, an additional mutation was effected to produce an “enhanced” green version of hGFP. In addition to the Ser65 to Thr65 substitution, Leu was substituted for Phe64. The enhanced hGFP thus was substituted with Leu64 in place of Phe64 where TTC encoding Phe was converted to CTG and also where Ser65, encoded by TCT was converted to Thr encoded by ACC.

Another point mutation, Tyr66 to His66, which resulted in blue fluorescence (Heim *et al.*, 1994) also was built into the humanized background of pTR<sub>BS</sub>-UF1 to produce the vector pTR<sub>BS</sub>-UFB.

An “enhanced” blue version was created by further converting Tyr145 to Phe66 in addition to the Tyr66 to His66 mutation. The base conversions were TAT to TTC and TAT to CAT respectively.

The modified versions of hGFP have a wide range of applications, particularly in the use of enhanced versions of the different colours. Mutated GFP and BFP (blue fluorescent protein) have different excitation and emission spectra with no overlap,

thereby allowing independent detection. Dual tagging permits rapid and specific identification of cells that express either of two or more fluorescently labeled proteins. Such methods are applicable to drug screening, for example, or analysis of agents that affect a target gene placed under the control of a constitutive promoter. Applications may also include study of gene expression under various stimuli or as affected by inhibitors.

To create the mutants, PCR™ reactions were performed, using pBS-GFP1 as a template and a pair of oligos, as defined below:

10

**For GFP2:**

#1: upstream primer; as described in Example IV;

#2:

5'-GCTTCATATGGTCTGGGTATCTGGAAAAGCACTGCACGCCATACCAGAAG  
GTAG-3'

15

(SEQ ID NO:11);

**For GFPB:**

#1: upstream primer; as described in Example IV;

#2:

5'-GCTTCATATGGTCTGGGTATCTGGAAAAGCACTGCACGCCATGAGAGAAG  
GTAG-3'

20

(SEQ ID NO:12)

25

To make the mutants, the PCR™ product was digested with *NdeI* and *XbaI* and substituted for the respective fragment of pBS-GFP1. The sequence was confirmed by sequencing the *NotI*-fragment, containing the mutant GFP cDNA, which was substituted for the *NotI*-fragment in pTR-UF1.

30

Although it is not believed to affect expression, in the mutants of humanized GFP, the inventors have again reverted codon 80 back to a wild type glutamine residue (Prasher *et al.*, 1992), as compared to arginine, as described by Chalfie *et al.* (1994).

To construct pTR<sub>BS</sub>-UF2 or pTR<sub>BS</sub>-UFB, the inventors substituted the *NotI* fragment of pBS-GFP<sub>H2</sub> (Thr<sub>65</sub>) or pBS-GFP<sub>HB</sub> (His<sub>66</sub>), respectively, for the *NotI* fragment of pTR<sub>BS</sub>-UF (FIG. 2A). Any DNA fragment that had undergone PCR amplification was sequenced to confirm the identity of the original sequence.

5 To construct pTR<sub>BS</sub>-UF3 the *EcoRI* site of the plasmid pSBC-1 (Dirks *et al.*, 1993) was converted into a *NotI* site after digestion with *EcoRI*, filling in the 5'-overhang with Klenow polymerase and ligation of *NotI* linkers. The 680 bp *NotI* fragment, consisting of a polylinker and the internal ribosome entry site (IRES) element of poliovirus type 1 was then subcloned into one of the *NotI* sites of  
10 pTR<sub>BS</sub>-UF2 (FIG. 2A).

To generate recombinant AAV (rAAV) virus, 293 cells were transfected with pTR<sub>BS</sub>-UF2 or pTR<sub>BS</sub>-UF3, and co-transfected with the helper plasmid pIM45, carrying the wt AAV genome without terminal repeats (McCarty *et al.*, 1991). The same cells were also infected with adenovirus at a multiplicity of infection (m.o.i.) of  
15 10.

Recombinant AAV was harvested after 60 h by freezing and thawing cells three times, heat-inactivating Ad for 30 min. at 56°C, spinning down cell debris and purifying the virus through a CsCl gradient (1.40 g/ml) formed in a SW41 rotor for 48 hrs at 200,000 g. The gradient was fractionated and the density was determined by  
20 refractometry. Fractions with densities between 1.38 and 1.4 g/cm<sup>3</sup> were pooled and dialyzed against DMEM media for 4 h. The AAV titer was determined by the infectious center assay (McLaughlin *et al.*, 1988).

## EXAMPLE VI

### 25 Increased Expression of Humanized GFP

The present example describes the increased expression of GFP that resulted from expressing the humanized GFP in 293 cells.

To compare the expression efficiency of the humanized *gfp* constructs with the original jellyfish sequence the inventors transfected 293 cells with pTR<sub>BS</sub>-UF, pTR<sub>BS</sub>-UF1, or pTR<sub>BS</sub>-UF2 plasmid DNA at various DNA concentrations. The transfected cells were then analyzed by FACS 36 hr after transfection (FIG. 3).

5 To monitor fluorescence, 293 cells were infected with CsCl-purified rAAV-GFP<sub>H</sub>2 at an M.O.I. of 10. At 36 hrs postinfection, the cells were photographed in a fluorescence microscope using a CHROMA Filter Cube #41014 GFP-HQ (excitation at 450+/-25 nm). Alternatively, after infection at an M.O.I. of 1 and selection with G418 for two weeks, three independent observers scored the  
10 number of green fluorescent cells within the G418 colonies by fluorescent microscopy. The mean of the frequencies obtained by the three observers was calculated. At least 11,500 cells in 150 separate colonies were scored for each viral preparation, rAAV-GFP<sub>J</sub>, rAAV-GFP<sub>H</sub>1 and rAAV-GFP<sub>H</sub>2.

15 Results from these studies revealed that pTR<sub>BS</sub>-UF1 carrying the humanized *gfp* sequence consistently produced 5-10 times higher number of cells scored as positive for green fluorescence than the jellyfish sequence. The point mutation in pTR<sub>BS</sub>-UF2 increased the number of fluorescent cells by an additional 5-10 fold over pTR<sub>BS</sub>-UF1.

20 At relatively low plasmid DNA concentrations, the difference between pTR<sub>BS</sub>-UF2 and pTR<sub>BS</sub>-UF was greater than 70 fold. At higher concentrations of transfected plasmid DNA, the difference in the number of cells expressing GFP was reduced. This result was consistent with the idea that the inability to translate the jellyfish *gfp* sequence could be overcome in part by increasing the gene copy number.

25 To determine whether the modified *gfp* cDNA was sufficient now to detect the marker gene at low gene copy number, the inventors isolated recombinant AAV viruses by packaging and using the three *gfp* constructs (UF, UF1, and UF2) and used them to transduce the *gfp* marker into 293 cells by virus infection. While there was almost no detectable GFP expression from a virus carrying the *gfp10* cDNA

-84-

(rAAV-GFP<sub>J</sub>), cells infected with a virus carrying the humanized *gfp<sub>h</sub>* gene (rAAV-GFP<sub>H1</sub>, or rAAV-GFP<sub>H2</sub>) were readily detected either visually (FIG. 4A and FIG. 4B), or by FACS analysis. FACS analysis was conducted by harvesting transfected 293 cells and analyzing on a flow cytometer (Becton-Dickinson) equipped for FITC detection at an excitation wavelength of 488 nm. At high M.O.I. (approximately 20) the ratio of infected cells, scored by FACS as fluorescent-positive, reached 70% for rAAV-GFP<sub>H2</sub>.

To determine more accurately the relative efficiency of the different *gfp* constructs, 293 cells infected at low multiplicity (MOI of 1) with rAAV-GFP<sub>J</sub>, rAAV-GFP<sub>H1</sub> or rAAV-GFP<sub>H2</sub> were first selected for the expression of the second reporter gene, *neoR*. G418 resistant colonies that have been transduced by an AAV-*neoR* recombinant virus have been shown by the inventors and others (Cheung *et al.*, 1980; Laughlin *et al.*, 1986; McLaughlin *et al.*, 1988; Samulski *et al.*, 1989) to contain an average of 2-3 copies of the recombinant viral genome integrated into host DNA.

293 cells were stably transduced with rAAV-GFP virus and selected for G418-resistance (200 mg/ml) for two weeks. Resistant colonies were trypsinized, pooled (at least 1000 colonies each for rAAV-GFP<sub>J</sub>, rAAV-GFP<sub>H1</sub> and rAAV-*gfp<sub>h2</sub>*), resuspended in OPTI-MEM media and analyzed by FACS as above.

Uninfected 293 cells have zero green fluorescent cells. After 2 weeks of selection approximately 11% of the UF1 transduced cells and 23% of the UF2 transduced cells that were G418-resistant were also found to express GFP, as judged by fluorescence microscopy. The visual pattern of GFP expression was patchy, with the number of green cells per colony ranging from 1% to about 100% (FIG. 5A, FIG. 5B, FIG. 5C and FIG. 5D). In contrast, only 0.5% of the G418-resistant cells containing the jellyfish GFP-coding rAAV-GFP<sub>J</sub> provirus were fluorescent.

Thus, optimization of the codon usage within the *gfp* gene increased the level of detection at low copy number by approximately 22 fold, and the Ser<sub>65</sub>Thr

substitution increased the level of detection by an additional two fold for a total of 45 fold.

Analysis of the G418 resistant cells by FACS, which may be inherently more sensitive to the level of expression, revealed similar differences in the level of detection between GFP<sub>J</sub>, GFP<sub>H1</sub> and GFP<sub>H2</sub> (FIG. 6A, FIG. 6B, FIG. 6C and FIG. 6D). In these studies, 0.05% of uninfected 293 cells were scored as exhibiting green fluorescence (i.e., background autofluorescence). No difference in the number of fluorescent cells was detected between GFP<sub>J</sub> and the uninfected parental 293 cells.

In contrast to GFP<sub>J</sub>, approximately 1.6% of the GFP<sub>H1</sub> and 10% of the GFP<sub>H2</sub> cells were scored positive for green fluorescence. Since no positive cells were detected with GFP<sub>J</sub>, it was difficult to judge accurately the difference in the frequency of detection between GFP<sub>J</sub> and GFP<sub>H2</sub>. However, conservative estimates of the frequency of detecting a green fluorescent cell in the humanized populations were at least 32-fold (GFP<sub>H1</sub>) and 190-fold (GFP<sub>H2</sub>) higher than the background frequency found for GFP<sub>J</sub> and uninfected parental 293 cells (FIG. 6A, FIG. 6B, FIG. 6C and FIG. 6D).

## EXAMPLE VII

### Expression of Humanized Blue GFP Variant

This example describes expression of a humanized blue GFP mutant, pTR<sub>BS</sub>-UFB, in 293 cells.

To monitor the fluorescence of the blue mutant, 293 cells on a 6 cm plate were cotransfected with pTR<sub>BS</sub>-UF2 and pTR<sub>BS</sub>-UFB plasmids, using Lipofectamine (GIBCO, Life Technologies). The DNA-liposome complex was formed separately for each plasmid and added to the same plate of cells. After 4 days cells were photographed in a fluorescence microscope using a Nikon Filter Cube V-2B.

-86-

As expected, the blue GFP mutant, pTR<sub>BS</sub>-UFB, when reproduced in a humanized background, induced 293 cells to fluoresce in a true blue color. However, the intensity of the fluorescence was considerably reduced compared to GFP<sub>H2</sub>. For example, FIG. 7 shows 293 cells co-transfected with pTR<sub>BS</sub>-UF2 and pTR<sub>BS</sub>-UFB, and viewed under conditions favoring the blue fluorescence. The inventors also noticed a rather fast (10-15 sec) bleaching of the blue fluorescence, when observing without a neutral density filter, which rarely happened with GFP<sub>H2</sub>.

It is contemplated that adding a nuclear localization signal within the blue mutant gene to localize the GFP within the much smaller space of the nucleus will enhance the fluorescence intensity, in an analogous manner to the mitochondrial targetting of Rizzuto *et al.* (1995). To create the GFPB-nuclear localization mutant, the following primers have been made:

#1:

5'-TGCTCTAGAGCGGCCCGCCGCCACCATGGTGCCCCAAGAAGAAGAGGAA  
GGTGATGAGCAAGGGCGAG-3'; (SEQ ID NO:13);

#2: primer #2 as for the GFPB PCR™, as described earlier.

### EXAMPLE VIII

#### Construction of IRES-GFP Cassette AAV Vector

This example describes the construction of the IRES-GFP cassette AAV vector in which translation of the GFP is controlled by an IRES element from Poliovirus type 1.

Oftentimes, the expression of the transduced gene of interest is hard to follow due to various technical reasons. On these occasions the monitoring of a marker gene delivered by the same vector is of a little help, since it is usually transcribed from a separate promoter. However, coordinate expression of both the reporter gene and the gene under study can be achieved if these genes are placed within one dicistronic



transcription unit. The cap-independent translational initiation of the second cistron in this array is mediated by an untranslated RNA sequence which functions as an internal ribosomal entry site (Jackson *et al.*, 1990; Jang *et al.*, 1988; Macejak and Sarnow, 1991).

5 To incorporate this feature into the inventor's AAV vectors, the inventors constructed the plasmid pTR<sub>BS</sub>-UF3, in which translation of the GFP is controlled by an IRES element from Poliovirus type 1 (Dirks *et al.*, 1993). A restriction site polylinker sequence also was inserted upstream of the IRES element to facilitate the insertion of the gene of interest, and the dicistronic messenger RNA was under the control of the CMV promoter (FIG. 2B and FIG. 2A).

10 The level of IRES-driven GFP expression with the pTR<sub>BS</sub>-UF3 vector, as judged by the fluorescence intensity, was lower than that seen with pTR<sub>BS</sub>-UF2, the parental plasmid, and was comparable to the pTR<sub>BS</sub>-UF1 vector. However, when another open reading frame (human B-chain insulin cDNA) was inserted upstream from the IRES element, the expression of GFP increased and was indistinguishable from the parent vector pTR<sub>BS</sub>-UF2.

## EXAMPLE IX

### Construction and Use of Recombinant GFP Adenovirus

20 The present example describes the construction of a recombinant adenovirus shuttle plasmid and the construction of recombinant adenovirus expressing humanized *gfp* gene. This exemplifies the use of different vector systems in humanized GFP expression.

25 To construct the adenovirus shuttle vector p $\Delta$ E1GFP (FIG. 2B) the parent plasmid pTR-UF3 was partially digested with *Sa*I and then digested to completion with *Bg*III. The transcription cassette consisting of the CMV promoter, intron, IRES element, GFP<sub>H</sub> cDNA and poly(A) site was isolated from an agarose gel. This

fragment was subcloned into p $\Delta$ E1sp1A (Bett *et al.*, 1994) which had been digested with *Bam*HI and *Sa*II.

To generate recombinant adenovirus the shuttle vector p $\Delta$ E1GFP (Bett *et al.*, 1994) and the Ad vector pJM17 (McGrory *et al.*, 1988) were cotransfected into 293 cells, using the procedure recommended by the supplier (Microbix Biosystems Inc). Plaques containing recombinant Ad were screened by visual selection under epifluorescence for a group of bright green cells displaying typical cytopathic effect (CPE). The recombinant Ad was designated Ad $\Delta$ E1GFP and propagated using standard techniques.

When p $\Delta$ E1*gfp* was recombined *in vivo* with a plasmid containing the remainder of the adenovirus genome, pJM17 (Snyder *et al.*, 1993), a recombinant adenovirus was produced which carried and expressed GFP (FIG. 8). The GFP reporter gene allowed an easy selection of recombinant Ad plaques. When examined by fluorescent microscopy, a true recombinant plaque consisted of a compact group of bright green cells displaying typical adenovirus CPE, whereas a false recombinant plaque contained no green cells. The ratio of true to false plaques was about 1:2, when using the combination of the p $\Delta$ E1*gfp* shuttle plasmid and the pJM17 donor plasmid. Thus, use of the GFP selection significantly simplified the screening process.

## EXAMPLE X

### Infection of Photoreceptor Cells of Guinea Pig

The present example describes the expression of the humanized, *gfp<sub>h</sub>*, cDNA and its use as a reporter gene in differentiated mammalian cells.

rAAV-GFP<sub>H</sub>1 was used to infect a retina of a guinea pig. Guinea pigs were anesthetized by intramuscular injection of ketamine (35mg/kg body weight) and xylazine (8mg/kg) mixture. Each eye was dilated with 2.5% phenylephrine (Neo-Synephrine) and 0.5% tropicamide, and a topical anesthetic (proparacaine HCl) was

administered to the cornea. The eye pressure was lowered by paracentesis of the anterior chamber. Then a 30 gauge needle was inserted at the pars plana into the vitreous under visual guidance of an indirect ophthalmoscope and 25 ml of rAAV-GFP<sub>H</sub>2 ( $2.5 \times 10^7$  infectious particles) was delivered. The eyes were examined  
5 by ophthalmoscopy for fluorescence and sites of inflammation.

At 28 days postinjection animals were anesthetized and euthanized with an intramuscular injection of ketamine HCl followed by an intraperitoneal pentobarbital sodium overdose. The animals were then perfused using 4% paraformaldehyde in 0.1 M PBS. The eyes were dissected out and the lens and cornea were removed. The  
10 retina and eye cup were additionally fixed overnight at 4°C. The retina were then infiltrated with 7.5%, 15%, and 30% sucrose and cryosectioned at 20-25 mm thickness. Tissue specimens were visualized using fluorescein excitation/emission filters on a Brorad confocal microscope.

To test the utility of GFP<sub>H</sub> cDNA as a reporter gene in an *in vivo* system, the  
15 inventors injected rAAV-GFP<sub>H</sub>2 virus into the vitreous body of the right eyes of two strain-13 guinea pigs. Tissue sections of the eye revealed weak GFP<sub>H</sub>2 fluorescence predominantly in cells of the ganglion cell layer (the layer closest to the vitreous injection). In addition, a few horizontal cells exhibited GFP<sub>H</sub>2 fluorescence. The greatest intensity of GFP<sub>H</sub>2 was seen in cells of the retinal pigment epithelium (RPE)  
20 (FIG. 9A, FIG. 9B, FIG. 9C and FIG. 9D).

With rAAV-GFP<sub>H</sub>2 every tissue section examined had RPE cells that fluoresced. This preference for CMV promoter driven expression in RPE cells has been previously noted (Bennett *et al.*, 1994; Li *et al.*, 1994). Examination of tissue specimens from the control left eyes revealed no cell specific emission except for  
25 autofluorescence within pigment granules of the RPE. The fact that inoculation of AAV into the guinea pig vitreous cavity lead to GFP expression in RPE cells demonstrated that AAV can traverse the neural retina, 100-200 mM thick. This property may be related to the small diameter of AAV particles.

## EXAMPLE XI

pGREENLANTERN™ VECTOR

This example describes the generation of a particularly useful vector, termed  
5 pGREENLANTERN™.

To create pCMVSPORT 2.1, the following protocol was used. pSPORT2  
(available from Life Technologies Inc., Gaithersburg, MD) was digested with *PvuII*  
and *BssHI*. The ends were made blunt by the action of Klenow fragment. The large  
fragment was gel purified.

10 pSVSPORT (available from Life Technologies Inc., Gaithersburg, MD) was  
than digested with *EarI* and *HaeII*. The ends were made blunt by the action of  
T4DNA polymerase. The smaller fragment was gel purified. The two fragments were  
ligated and the resulting plasmid was called pRAD-TEMP.

pRAD-TEMP was partialled with *BamHI* and treated with Klenow. The DNA  
15 was self ligated and the resulting plasmid had only one *BamHI* site in the multiple  
cloning site (MCS). The MCS was changed by cutting the DNA with *XbaI* and *MluI*  
and ligating a new oligo that had the following restriction sites (*XbaI*-*BamHI*-*XhoI*-  
*ApaI*-*HindII* and *MluI*). This plasmid was called pSVSPORT-B1.

pSVSPORT-B1 was digested with *ClaI* and *StuI*, treated with Klenow  
20 fragment. The CMV promoter was from pCMV $\beta$ gal. The promoter was on a *SfcI*-  
*XbaI* fragment that was made blunt with Klenow fragment. The DNAs were ligated  
and the resulting plasmid was called pCMVSPORT 2.1

To create pGREENLANTERN, pCMVSPORT 2.1 was utilized.  
pCMVSPORT 2.1 was digested with *NotI* and treated with Calf intestinal alkaline  
25 phosphatase. The DNA was ligated to the *NotI* fragment of the humanized UF2. The  
orientation was confirmed. The vector was called pCMVSPORT-UF2.

-91-

The T7 DNA polymerase region was deleted by digestion with *XbaI-NheI* and self ligation of the larger vector fragment. This DNA is the pGREENLANTERN-1 vector (FIG. 10). The complete sequence of pGREENLANTERN-1 is given in SEQ ID NO:14.

5

\* \* \*

All of the compositions and methods disclosed and claimed herein can be made and executed without undue experimentation in light of the present disclosure. While the compositions and methods of this invention have been described in terms of preferred embodiments, it will be apparent to those of skill in the art that variations may be applied to the composition, methods and in the steps or in the sequence of steps of the method described herein without departing from the concept, spirit and scope of the invention. More specifically, it will be apparent that certain agents that are both chemically and physiologically related may be substituted for the agents described herein while the same or similar results would be achieved. All such similar substitutes and modifications apparent to those skilled in the art are deemed to be within the spirit, scope and concept of the invention as defined by the appended claims.

10

15

**REFERENCES**

The following references, to the extent that they provide exemplary procedural or other details supplementary to those set forth herein, are specifically incorporated herein by reference.

Adams *et al.*, "Vectors for using green fluorescent protein (gfp) as a reporter of gene expression and protein localization in mammalian cells", *FASEB J.*, 9(6):A1336, Abstract #465, 1995.

Adams *et al.*, *In: Fluorescent Probes for Biological Activity of Living Cells: A Practical Guide*, ed. Mason, Academic, New York, pp. 133-149, 1993.

Adams *et al.*, *Nature (London)*, 349:694-697, 1991.

Adelman *et al.*, *DNA*, 2:183, 1983.

Baichwal *et al.*, "Vectors for gene transfer derived from animal DNA viruses: Transient and stable expression of transferred genes," *In: Kucherlapati R, ed. Gene transfer.* New York: Plenum Press, pp. 117-148, 1986.

Bennett, J., J. Wilson, D. Sun, B. Forbes, and A. Maguire, , "Adenovirus Vector-Mediated *in vivo* Gene Transfer Into Adult Murine Retina," *Invest. Ophthalmol. Vis. Sci.*, 35:2535-2542, 1994.

Bennetzen, J.L. and B.D. Hall, "Codon Selection in Yeast," *The Journal of Biological Chemistry*, 257(6):3026-3031, March, 1982.

Bett, A.J., W. Haddara, L. Prevac, and F.L. Graham,, "An Efficient and Flexible System for Construction of Adenovirus Vectors with Insertions or Deletions in Early Regions 1 and 3," *Proc. Natl. Acad. Sci. USA*, 91:8802-8806, 1994.

Bittner *et al.*, *Methods in Enzymol.*, 153:516-544, 1987.

Chalfie, M., Y. Tu, G. Euskirchen, W.W. Ward, and D.C. Prasher,, "Green Fluorescent Protein as a Marker For Gene Expression," *Science*, 263:802-805, 1994.

Chang *et al.*, "Foreign gene delivery and expredion in hepatocytes using a hrpatitis B virus vector," *Hepatology*, 14:134A, 1991.

- Cheung, A.K., M.D. Hoggan, W.W. Hauswirth, and K.I. Berns, "In, "Integration of the Adeno-Associated Virus Genome Into Cellular *DNA* in Latently Infected Human Detroit 6 Cells," *J. Virol.*, 33:739-748, 1980.
- 5 Clark, K.R., F. Voulgaropoulou, D.M. Fraley, and P.R. Johnson, 1995. Cell lines for the production of recombinant adeno-associated virus. *Human Gene Therapy* 6:1329-1341.
- 10 Cody, C.W., D.C. Prasher, W.M. Westler, F.G. Prendergast, and W.W. Ward, "Chemical Structure of the Hexapeptide Chromophore of The Aequorea Green-Fluorescent Protein," *Biochemistry*, 32:1212-1218, 1993.
- Cohen, "Naked DNA Points Way to Vaccines," *Science*, 259:1691-1692, 1993.
- 15 Colberre-Garapin *et al.*, *J. Mol. Biol.*, 150:1, 1981.
- Coupar *et al.*, "A general method for the construction of recombinant vaccinia virus expressing multiple foreign genes," *Gene*, 68:1-10, 1988.
- 20 Cox *et al.*, *J. Virol.* 67(9):5664-5667, 1993.
- Crea *et al.*, *Proc. Natl. Acad. Sci. USA*, 75:5765, 1978.
- 25 Culver, K.W., Ram, Z., Wallbridge, S., Ishii, H., Oldfield, E.H., and Blaese, R.M. In vivo gene transfer with retroviral vector-producer cells for treatment of experimental brain tumors. *Science*, 256: 1550-1552, 1992.
- Current Protocols in Molecular Biology*, John Wiley & Sons, chapter 8, 1995.
- 30 Cutler and Ward, 1993.
- Delagrave and Youvan, "Searching sequence space to engineer proteins: Exponential ensemble mutagenesis," *Bio/Technology*, 11:1548-1552, 1993.
- 35 Delagrave *et al.*, "Recursive ensemble mutagenesis," *Protein Engineering*, 6:327-331, 1993.
- 40 Delagrave *et al.*, "Red-Shifted Excitation Mutants of the Green Fluorescent Protein," *Bio/Technology*, 13:151-154, February, 1995.
- Dirks, W., M. Wirth, and H. Hauser, "Dicistronic Transcription Units for Gene Expression in Mammalian Cells," *Gene*, 128:247-249, 1993.
- 45 Dopf and Horiagon, *Fluorescent Proteins and Applications Meeting*, Palo Alto, California (Abstract), 1995.

- Ehrig *et al.*, *FEBS Lett.*, 367:163-166, 1995.
- Eichenlaub, *J. Bacteriol.*, 138:559-566, 1979.
- 5 Flotte, T.R., Solow, R., Owens, R.A., Afione, S.A., Zeitlin, P.L., and Carter, B.J.  
1992. Gene expression from adeno associated virus vector in airway epithelial  
cells. *Am. J. Respir. Cell Mol. Biol.* 7:349-356.
- 10 Flotte, T.R., Afione, S.A., Conrad, C., McGrath, S.A., Solow, R., Oka, H., Zeitlin,  
P.L., Guggino, W.B., and Carter, B.J. 1993. Stable in vivo expression of the  
cystic fibrosis transmembrane conductance regulator with an adeno-associated  
virus vector. *Proc. Natl. Acad. Sci. USA.* 90:10613-10617.
- 15 Flotte, T.R., Afione, S.A., and Zeitlin, P.L. 1994. Adeno-associated virus vector gene  
expression occurs in nondividing cells in the absence of vector DNA  
integration. *Am.J. Respir. Cell Mol. Biol.* 11:517-521.
- 20 Flotte, T.R., Barraza-Ortiz, X., Solow, R., Afione, S.A., Carter, B.J., and Guggino, W.  
B. 1995. An improved system for packaging recombinant adeno-associated  
virus vectors capable of in vivo transduction. *Gene Therapy* 2, 29-37.
- Freedman *et al.*, *Journal of Biological Chemistry*, 268:2254, 1993.
- 25 Fynan *et al.*, "DNA vaccines: Protective immunizations by parenteral, mucosal, and  
gene-gun inoculations," *Proc. Natl. Acad. Sci. USA*, 90:11478-11482, 1993.
- Gal *et al.*, *Lab. Invest.*, 68(1):18, 1993.
- 30 Ghosh-Choudhury and Graham, *Biochem. Biophys. Res. Comm.*, 147:964-973, 1987.
- Gluzman *et al.*, *In: Eukaryotic Viral Vectors* (Gluzman, Y., ed) pp. 187-192, Cold  
Spring Harbor Press, Cold Spring Harbor, New York, 1982.
- 35 Goldman and Youvan, "An algorithmically optimized combinatorial library screened  
by digital imaging spectroscopy," *Bio/Technology*, 10:1557-1561, 1992.
- 40 Gopal, "Gene transfer method for transient gene expression, stable transfection, and  
cotransfection of suspension cell cultures," *Mol. Cell Biol.*, 5:1188-1190,  
1985.
- Graham and van der Eb, "A new technique for the assay of infectivity of human  
adenovirus 5 DNA", *Virology*, 52:456-467, 1973.
- 45 Grantham, *et al.*, "Codon Catalog Usage and the Genome Hypothesis," *Nucleic Acids  
Research*, 8(1):r49-r62, 1980.



- Grantham, R., C. Gautier, M. Gouy, M. Jacobzone, and R. Mercier, "Codon Catalog Usage is a Genome Strategy Modulated for Gene Expressivity," *Nucleic Acids Research*, 9(1):r43-r74, 1981.
- 5 Heim, R., A.B. Cubitt, and R.Y. Tsien, "Improved green fluorescence," *Nature*, 373:663-664, February, 1995.
- Heim, R., A.B. Cubitt, and R.Y. Tsien, "Wavelength Mutations and Posttranslational Autoxidation of Green Fluorescent Protein," *Proc. Natl. Acad. Sci. USA*, 10 91:12501-12504, 1994.
- Hermonat, P.L., and Muzyczka, N. 1984. Use of adeno-associated virus as a mammalian DNA cloning vector; transduction of neomycin resistance into mammalian tissue culture cells. *Proc. Natl. Acad. Sci. USA*. 81:6466-6470.
- 15 Horwich *et al.* "Synthesis of hepadenovirus particles that contain replication-defective duck hepatitis B virus genomes in cultured HuH7 cells," *J. Virol.*, 64:642-650, 1990.
- 20 Ikemura, T., "Correlation Between the Abundance of *Escherichia coli* Transfer RNAs and the Occurrence of the Respective Codons in its Protein Genes," *J. Mol. Biol.*, 146:1-21, 1981.
- Ikemura, T., "Correlation Between the Abundance of *Escherichia coli* Transfer RNAs and the Occurrence of the Respective Codons in its Protein Genes: A Proposal for a Synonymous Codon Choice that is Optimal for the *E. coli* Translational System," *J. Mol. Biol.*, 151:389-409, 1981.
- 25 Ikemura, T., "Correlation Between the Abundance of Yeast Transfer RNAs and the Occurrence of the Respective Codons in Protein Genes. Differences in Synonymous Codon Choice Patterns of Yeast and *Escherichia coli* with reference to the Abundance of Isoaccepting Transfer RNAs," *J. Mol. Biol.*, 158:573-597, 1982.
- 30 Ikemura, T., "The Frequency of Codon Usage in *E. coli* Genes: Correlation With Abundance of Cognate tRNA," p. 519-534, *In: S. Osawa et al. (ed.), "Genetics And Evolution of RNA Polymerase, tRNA, And Ribosomes," University of Tokyo Press, Tokyo and Elsevier/North Holland, Amsterdam, 1980.*
- 35 Inouye and Tsuji, *FEBS Lett.*, 341:277-280, 1994.
- Jackson, R.J., M.T. Howell, and A. Kaminski, "The Novel Mechanism of Initiation of Picornavirus RNA Translation," *Trends. Biochem. Sci.*, 15:477-483, 1990.
- 40 Jang, S.K., H.G. Krausslich, M.J. Nicklin, G.M. Duke, A.C. Palmenberg, and E. Wimmer, "A Segment of The 5' Nontranslated Region of
- 45

Encephalomyocarditis Virus RNA Directs Internal Entry of Ribosomes During *in vitro* Translation," *J. Virol.*, 62:2636-2643, 1988.

5 Jiao *et al.*, "Particle Bombardment-Mediated Gene Transfer and Expression in Rat Brain Tissues", *BIO/TECHNOLOGY*, 11:497-502, 1993.

10 Kaplitt, M.G., Leone, P., Samulski, R.J., Siao, X., Pfaff, D.W., O'Malley, K.L., and During, M.J. 1994. Long-term gene expression and phenotypic correction using adeno-associated virus vectors in the mammalian brain. *Nature Genetics*. 8:148-154.

Karlsson *et al.*, *EMBO J.*, 5:2377-2385, 1986.

15 Kasahara *et al.*, *Science*, 266:1373-1376, 1994.

Kotin, R.M., Siniscalco, M., Samulski, R.J., Zhu, Z., Hunter, C.A., McLaughlin, S., Muzyczka, N., and Berns, K.I. 1990. Site-specific integration by adeno-associated virus. *Proc. Natl. Acad. Sci. USA* 87:2211-2215.

20 Kozak, M., "At Least Six Nucleotides Preceding the AUG Initiator Codon Enhance Translation in Mammalian Cells," *J. Mol. Biol.*, 196:947-950, 1987.

25 Kozak, M., "Downstream Secondary Structure Facilitates Recognition of Initiator Codons by Eukaryotic Ribosomes," *Proc. Natl. Acad. Sci. USA*, 87:8301-8305, 1990.

30 LaFace, D., Hermonat, P., Wakeland, E., and Peck, A. 1988. Gene transfer into hematopoietic progenitor cells mediated by an adeno-associated virus vector. *Virology*. 162:483-486.

Laughlin, C.A., C.B. Cardellicchio, and H.C. Coon, "Latent Infection of KB Cells with Adeno-Associated Virus Type 2," *J. Virol.*, 60:515-524, 1986.

35 Lebkowski, J.S., McNally, M.M., Okarma, T.B., and Lerch, L.B. 1988. Adeno-associated virus: a vector system for efficient introduction and integration of DNA into a variety of mammalian cell types. *Mol. Cell. Biol.* \*:3988-3996.

Ledley, J. (1987). *J. Pediatrics* **110**, 1.

40 Li, T., M. Adamian, D. J. Roof, E.L. Berson, T.P. Dryja, B.J. Roessler, and B.L. Davidson, "In vivo Transfer of a Reporter Gene to the Retina Mediated by an Adenoviral Vector," *Invest. Ophthalmol. Vis. Sci.*, 35:2543-2549, 1994.

45 Lim *et al.*, *J. Biochem. (Tokyo)*, 118:13-17, 1995.

Lowy *et al.*, *Cell*, 22:817, 1980.

- 5 Luo, F., Zhou, S.Z., Cooper, S., Munshi, N.C., Boswell, H.S., Broxmeyer, H.E., and Srivastava, A. 1994. Adeno-associated virus 2 mediated transfer and functional expression of a gene encoding the human granulocyte-macrophage colony-stimulating factor. *Blood*. 82:suppl. 1,303A.
- Macejak, D.G. and P. Sarnow, "Internal Initiation of Translation Mediated by the 5' Leader of a Cellular *mRNA* [see comments]," *Nature*, 353:90-94, 1991.
- 10 McCarty, D.M., M. Christensen, and N. Muzyczka, "Sequences Required for Coordinate Induction of Adeno-Associated Virus p19 and p40 Promoters by Rep Protein," *J. Virol.*, 65:2936-2945, 1991.
- 15 McGrory, W.J., D.S. Bautista, and F.L. Graham, "A Simple Technique for the Rescue of Early Region I Mutations Into Infectious Human Adenovirus Type 5," *Virology*, 163:614-617, 1988.
- 20 McLaughlin, S.K., P. Collis, P.L. Hermonat, and N. Muzyczka, "Adeno-Associated Virus General Transduction Vectors: Analysis of Proviral Structures," *J. Virol.*, 62:1963-1973, 1988.
- Messing *et al.*, Third Cleveland Symposium on Macromolecules and Recombinant DNA, Editor A. Walton, Elsevier, Amsterdam, 1981.
- 25 Miller 1992, *Curr. Top. Microbiol. Immunol.* **158**:1
- Morin, J.G. and J.W. Hastings, "Energy Transfer in a Bioluminescent System," *J. Cell Physiol*, 77:313-318, 1971.
- 30 Morise *et al.*, *Biochemistry*, 13:2656-2662, 1974.
- Muhlrads *et al.*, *Yeast*, 8:79-82, 1992.
- Mulligan *et al.*, *Proc. Natl. Acad. Sci. USA*, 78:2072, 1981.
- 35 Muzyczka, N., "Use of Adeno-Associated Virus as a General Transduction Vector for Mammalian Cells," *Curr. Top. Microbiol. Immunol.*, 158:97-129, 1992.
- Muzyczka, N. 1991. Use of AAV as a general transduction vector for mammalian cells. In: *Curr. Top. Micro. Imm. Viral Expression Vectors* (N. Muzyczka, ed), vol 158,pg 97-129. Springer Verlag, Berlin.
- 40 Nicolau, C., *et al.* (1983). *Proc. Natl. Acad. Sci. U.S.A.* **80**, 1068.
- 45 Nicolau and Sene, "Liposome-mediated DNA transfer in eukaryotic cells," *Biochem. Biophys. Acta*, 721:185-190, 1982.

O'Hare *et al.*, *Proc. Natl. Acad. Sci. USA*, 78:1527, 1981.

5 Ohi, S., Dixit, M., Tillery, M.K., and Plonk, S.G. 1990. Construction and replication of an adeno-associated virus expression vector that contains human  $\lambda$ -globin cDNA. *Gene*.89L:279-282.

10 Pelletier and Sonenberg, "Internal initiation of translation of eukaryotic mRNA directed by a sequence derived from poliovirus RNA," *Nature*, 334:320-325, 1988.

Perozzo *et al.*, *J. Biol. Chem.*, 263:7713-7716, 1988.

15 Pines, "GFP in *Dictyostelium*," *TIG*, 11(8):326-327, August, 1995.

Potter *et al.*, "Enhancer-dependent expression of human k immunoglobulin genes introduced into mouse pre-B lymphocytes by electroporation," *Proc. Nat'l Acad. Sci. USA*, 81:7161-7165, 1984.

20 Prasher, D.C., V.K. Eckenrode, W.W. Ward, F.G. Prendergast, and M.J. Cormier, "Primary Structure of the Aequorea Victoria Green-Fluorescent Protein," *Gene*, 111:229-233, 1992.

25 Ridgeway, "Mammalian expression vectors," *In: Rodriguez RL, Denhardt DT, ed. Vectors: A survey of molecular cloning vectors and their uses.* Stoneham: Butterworth, pp. 467-492, 1988.

30 Rippe *et al.*, "DNA-mediated gene transfer into adult rat hepatocytes in primary culture," *Mol. Cell Biol.*, 10:689-695, 1990.

Rizzuto *et al.*, "Chimeric green fluorescent protein as a tool for visualizing subcellular organelles in living cells," *Current Biology*, 5(6):635-642, 1995.

35 Rosenfeld, M. A., Siegfried, W., Yoshimura, K., Yoneyama, K., Fukayama, M., Stier, L. E., Pääkkö, P. K., Gilardi, P., Stratford-Perricaudet, L. D., Perricaudet, M., Jallat, S., Pavirani, A., Lecocq, J. -P., and Crystal, R. G. *Science*, 252:431-434, 1991.

40 Rosenfeld, M. A., Yoshimura, K., Trapnell, B. C., Yoneyama, K., Rosenthal, E. R., Dalemans, W., Fukayama, M., Bargon, J., Stier, L. E., Stratford-Perricaudet, L. D., Perricaudet, M., Guggino, W. B., Pavirani, A., Lecocq, J. -P., and Crystal, R. G. *Cell*, 68:143-155, 1992.

45 Ryan *et al.*, "Sequence Requirements For Binding of Rep68 to the Adeno-Associated Virus Terminal Repeats," *J. Virol.*, 1995.

- Sambrook *et al.* (1989). *Molecular cloning: A laboratory manual*. Cold Spring Harbor Laboratory. Cold Spring Harbor, NY.
- 5 Samulski, R.J., L.S. Chang, and T. Shenk, "Helper-Free Stocks of Recombinant Adeno-Associated Viruses: Normal Integration Does Not Require Viral Gene Expression," *J. Virol.*, 63:3822-3828, 1989.
- 10 Samulski, R.J., Berns, K.I., Tan, M. and N. Muzyczka. (1982) Cloning of AAV into pBR322: Rescue of intact virus from the recombinant plasmid in human cells. *Proc.Natl.Acad.Sci. USA* 79-2077-2081.
- 15 Samulski, R.J., Chang, L.S., and Shenk, T. 1989. Helper-free stocks of recombinant adeno-associated viruses: Normal integration does not require viral gene expression. *J. Virol.* 63:3822-3828.
- Samulski, R.J., Zhu, X., Xiao, Z., Brook, J.D., Housman, D.E., Epstein, N. and Hunter, L.A. 1991. Targeted integration of adeno-associated virus (AAV) into human chromosome 19. *EMBOJ.* 10:3941-3950.
- 20 Santerre *et al.*, *Gene*, 30:147, 1984.
- Shelling, A.N., and Smith, M.G. 1994. Targeted integration of transfected and infected adeno-associated virus vectors containing the neomycin resistance gene. *Gene Therapy.* 1:165-169.
- 25 Shimomura, O., "Structure of the Chromophore of the Aequorea Green Fluorescent Protein," *FEBS. Lett.*, 104:220-222, 1979.
- Sikorski and Boeke, *Methods Enzymol.*, 194:302-318, 1991.
- 30 Snyder, R.O., D.S. Im, T. Ni, X. Xiao, R.J. Samulski, and N. Muzyczka, "Features of The Adeno-Associated Virus Origin Involved in Substrate Recognition by the Viral Rep Protein," *J. Virol.*, 67:6096-6104, 1993.
- 35 Stewart *et al.*, 1992, *Hum. Gene Ther.* 3:267
- Stratford-Perricaudet, L. D., Levrero, M., Chasse, J. -F., Perricaudet, M., and Briand, P. *Hum. Gene Ther.*, 1:241-256, 1990.
- 40 Stratford-Perricaudet, L. D., Makeh, I., Perricaudet, M., and Briand, P. *J. Clin. Invest.*, 90:626-630, 1992.
- Stringham *et al.*, *Molecular Biology of the Cell*, 3:221, 1992.
- 45 Surpin and Ward, *Photochem. Photobiol.*, 45:62S, 1989.

Szybalska *et al.*, *Proc. Natl. Acad. Sci. USA*, 48:2026, 1962.

Tang *et al.*, *Nature*, 356:152-154, 1992.

5 Thomsen *et al.*, *Proc. Natl. Acad. Sci. USA*, 81:659-663, 1984.

Torchilin *et al.*, 1992, *Faseb J.* 6:2716

10 Tratschin, J.D., West, M.H., Sandbank, T., and Carter, B.J. 1984. A human parvovirus, adeno-associated virus, as a eucaryotic vector: transient expression and encapsidation of the procaryotic gene for chloramphenicol acetyltransferase. *Mol.Cell.Biol.* 4:2072-2081.

15 Tratschin, J.D., Miller, I.L., Smith, M.G., and Carter, B.J. 1985. Adeno-associated virus vector for high-frequency integration, expression and rescue of genes in mammalian cells. *Mol.Cell.Biol.* 5:32581-3260.

Tur-Kaspa *et al.*, "Use of electroporation to introduce biologically active foreign genes into primary rat hepatocytes," *Mol. Cell Biol.*, 6:716-718, 1986.

20 Ulmer *et al.*, "Heterologous Protection Against Influenza by Injection of DNA Encoding a Viral Protein," *Science*, 259:1745-1749, 1993.

25 Wada, K., S. Aota, R. Tsuchiya, F. Ishibashi, T. Gojobori, and T. Ikemura, "Codon Usage Tabulated from the GenBank Genetic Sequence Data," *Nucleic Acids Research*, 18(Supplement):2367-2411, 1990.

30 Walsh, C.E. Nienhuis, A.W., Samulski, R.J., Brown, M.G., Miller, J.L., Young, N.S., and Liu, J.M. 1994. Phenotypic correction of Fanconi anemia in human hematopoietic cells with a recombinant adeno-associated virus vector. *Proc.Natl.Acad.Sci. USA.* 89:7257-7261.

35 Walsh, C.E., Nienhuis, A.W., Samulski, R.J., Brown, M.G., Miller, J.L., Young, N.S., and Liu, J.M. 1994. Phenotypic correction of Fanconi anemia in human hematopoietic cells with a recombinant adeno-associated virus vector. *J.Clin.Invest.* 94:1440-1448.

Wampler *et al.*, *Biochem. Biophys. Acta*, 314:104-109, 1973.

40 Wang and Hazelrigg, *Nature*, 369:400-403, 1994.

Wang *et al.*, *Proc. Natl. Acad. Sci. USA*, 90:4156-4160, 1993.

45 Ward and Bokman, *Biochemistry*, 21:4535-4540, 1982.

- Ward, W.W., C.W. Cody, R.C. Hart, and M.J. Cormier, "Adeno-Associated Virus DNA Replication *in vitro*: Activation by a Maltose Binding Protein/Rep 68 Fusion Protein," *J. Virol.*, 68:6029-6037, 1994.
- 5 Ward *et al.*, "Spectrophotometric Identity of the Energy-Transfer Chromophores in Renilla And Aequorea Green Fluorescent Proteins," *Photochem. Photobiol.*, 31:611-615, 1980.
- Ward *et al.*, *Photochem. Photobiol.*, 35:803-808, 1982.
- 10 Ward, In: *Bioluminescence and Chemiluminescence: Basic Chemistry and Analytical Applications* (DeLuca and McElroy, eds.), Academic Press, pp. 235-252, 1981.
- 15 Wei, J.F., Wei, F-S., Samulski, R.J., and Barranger, J.A. 1994. Expression of the human glucocerebrosidase and arylsulfatase A genes in murine and patient primary fibroblasts transduced by an adeno-associated virus vector. *Gene Therapy*. 1:261-268.
- 20 Yang, Q., Chen, F.Y., Trempe, J.P. 1994. Characterization of cell lines that inducibly express the adeno-associated virus Rep proteins. *J. Virol.* 68:4847-4856.
- Yoder, M.C., Kang, L.Y., Zhou, S.Z., Luo, F., and Srivastava, A. 1994. In vivo gene transfer in murine hematopoietic reconstituting stem cells mediated by the
- 25 adeno-associated virus 2-based vectors. *Blood*. 82:suppl. 1:347A.
- Welch, *Scientific American*, p. 56, May, 1993.
- Whitton *et al.*, *J. Virol.* 67:(1)348-352,1993.
- 30 Wigler *et al.*, *Cell*, 11:223, 1977.
- Wigler *et al.*, *Proc. Natl. Acad. Sci. USA*, 77:3567, 1980.
- 35 Wolff, J.A., Malone, R.W., Williams, P., Chong, W., Acsadi, G., Jani, A., and Felgner, P.L. (1990) Direct gene transfer into mouse muscle *in vivo*. *Science* 247,1465-1468.
- Youvan, "Imaging sequence space," *Nature*, 369:79-80, 1994.
- 40 Youvan *et al.*, "Digital imaging spectroscopy for massively parallel screening of mutants," *Methods in Enzymology*, 246:732-748, 1995.
- Zhou, S.Z., Broxmyer, H.E., Cooper, S., Harrington, M.A., and Srivastava, A. 1993.
- 45 Adeno-associated virus 2 mediated gene transfer in murine hematopoietic cells. *Exp. Hematol. (NY)*. 21:928-933.

5 Zhou, S.Z., Cooper, S., Kang, L.Y., Ruggieri, L., Heimfeld, S., Srivastava, A., and Broxmeyer, H.E. 1994. Adeno-associated virus 2-mediated high efficiency gene transfer into immature and mature subsets of hematopoietic progenitor cells in human umbilical cord blood. *J.Exp.Med.* 179:1867-1875.

Zhu, *et al.*, 1993, *Science* 261:209-211.



-103-

SEQUENCE LISTING

## (1) GENERAL INFORMATION:

## (i) APPLICANT:

- (A) NAME: University of Florida Research Foundation,  
Incorporated
- (B) STREET: 223 Grinter Hall
- (C) CITY: Gainesville
- (D) STATE: Florida
- (E) COUNTRY: USA
- (F) POSTAL CODE (ZIP): 32611
- (G) TELEPHONE:
- (H) TELEFAX:

(ii) TITLE OF INVENTION: HUMANIZED GREEN FLUORESCENT PROTEIN  
GENES AND METHODS

(iii) NUMBER OF SEQUENCES: 14

## (iv) COMPUTER READABLE FORM:

- (A) MEDIUM TYPE: Floppy disk
- (B) COMPUTER: IBM PC compatible
- (C) OPERATING SYSTEM: PC-DOS/MS-DOS
- (D) SOFTWARE: PatentIn Release #1.0, Version #1.30 (EPO)

## (v) CURRENT APPLICATION DATA:

APPLICATION NUMBER: Unknown

## (vi) PRIOR APPLICATION DATA:

- (A) APPLICATION NUMBER: US 08/588,201
- (B) FILING DATE: 18-JAN-1996

## (2) INFORMATION FOR SEQ ID NO: 1:

## (i) SEQUENCE CHARACTERISTICS:

- (A) LENGTH: 717 base pairs
- (B) TYPE: nucleic acid
- (C) STRANDEDNESS: single
- (D) TOPOLOGY: linear

## (xi) SEQUENCE DESCRIPTION: SEQ ID NO: 1:

```

ATGAGTAAAG GAGAAGAACT TTCTACTGGA GTTGTCCTCAA TTCTTGTTGA ATTAGATGGT 60
GATGTTAATG GGCACAAATT TTCTGTCAGT GGAGAGGGTG AAGGTGATGC AACATACGGA 120
AAACTTACCC TTAAATTTAT TTGCACTACT GGAAACTAC CTGTTCCATG GCCAACACTT 180
GTCACTACTT TCTCTTATGG TGTTCAATGC TTTTCAAGAT ACCCAGATCA TATGAAACAG 240
CATGACTTTT TCAAGAGTGC CATGCCCGAA GGTATGTAC AGGAAAGAAC TATATTTTTC 300
AAAGATGACG GGAAGTACAA GACACGTGCT GAAGTCAAGT TTGAAGGTGA TACCCTTGTT 360

```

AATAGAATCG AGTTAAAAGG TATTGATTTT AAAGAAGATG GAAACATTCT TGGACACAAA 420  
 TTGGAATACA ACTATAACTC ACACAATGTA TACATCATGG CAGACAAACA AAAGAATGGA 480  
 ATCAAAGTTA ACTTCAAAAT TAGACACAAC ATTGAAGATG GAAGCGTTCA ACTAGCAGAC 540  
 CATTATCAAC AAAATACTCC AATTGGCGAT GGCCCTGTCC TTTTACCAGA CAACCATTAC 600  
 CTGTCCACAC AATCTGCCCT TTCGAAAGAT CCCAACGAAA AGAGAGACCA CATGGTCCTT 660  
 CTTGAGTTTG TAACAGCTGC TGGGATTACA CATGGCATGG ATGAACTATA CAAATAA 717

(2) INFORMATION FOR SEQ ID NO: 2:

(i) SEQUENCE CHARACTERISTICS:

- (A) LENGTH: 238 amino acids
- (B) TYPE: amino acid
- (C) STRANDEDNESS:
- (D) TOPOLOGY: linear

(ix) FEATURE:

- (A) NAME/KEY: Modified-site
- (B) LOCATION:65
- (D) OTHER INFORMATION:/product= "OTHER"  
 /note= "Xaa = Ser or Ther"

(ix) FEATURE:

- (A) NAME/KEY: Modified-site
- (B) LOCATION:66
- (D) OTHER INFORMATION:/product= "OTHER"  
 /note= "Xaa = Tyr or His"

(xi) SEQUENCE DESCRIPTION: SEQ ID NO: 2:

Met	Ser	Lys	Gly	Glu	Glu	Leu	Phe	Thr	Gly	Val	Val	Pro	Ile	Leu	Val
1				5					10					15	
Glu	Leu	Asp	Gly	Asp	Val	Asn	Gly	His	Lys	Phe	Ser	Val	Ser	Gly	Glu
			20					25					30		
Gly	Glu	Gly	Asp	Ala	Thr	Tyr	Gly	Lys	Leu	Thr	Leu	Lys	Phe	Ile	Cys
			35				40						45		
Thr	Thr	Gly	Lys	Leu	Pro	Val	Pro	Trp	Pro	Thr	Leu	Val	Thr	Thr	Phe
			50			55						60			
Xaa	Xaa	Gly	Val	Gln	Cys	Phe	Ser	Arg	Tyr	Pro	Asp	His	Met	Lys	Gln
65					70					75					80
His	Asp	Phe	Phe	Lys	Ser	Ala	Met	Pro	Glu	Gly	Tyr	Val	Gln	Glu	Arg
				85					90					95	
Thr	Ile	Phe	Phe	Lys	Asp	Asp	Gly	Asn	Tyr	Lys	Thr	Arg	Ala	Glu	Val

-105-

	100							105						110	
Lys	Phe	Glu	Gly	Asp	Thr	Leu	Val	Asn	Arg	Ile	Glu	Leu	Lys	Gly	Ile
		115						120				125			
Asp	Phe	Lys	Glu	Asp	Gly	Asn	Ile	Leu	Gly	His	Lys	Leu	Glu	Tyr	Asn
		130						135				140			
Tyr	Asn	Ser	His	Asn	Val	Tyr	Ile	Met	Ala	Asp	Lys	Gln	Lys	Asn	Gly
145						150				155					160
Ile	Lys	Val	Asn	Phe	Lys	Ile	Arg	His	Asn	Ile	Glu	Asp	Gly	Ser	Val
						165				170					175
Gln	Leu	Ala	Asp	His	Tyr	Gln	Gln	Asn	Thr	Pro	Ile	Gly	Asp	Gly	Pro
						180				185				190	
Val	Leu	Leu	Pro	Asp	Asn	His	Tyr	Leu	Ser	Thr	Gln	Ser	Ala	Leu	Ser
						195				200			205		
Lys	Asp	Pro	Asn	Glu	Lys	Arg	Asp	His	Met	Val	Leu	Leu	Glu	Phe	Val
						210				215			220		
Thr	Ala	Ala	Gly	Ile	Thr	His	Gly	Met	Asp	Glu	Leu	Tyr	Lys		
225						230				235					

## (2) INFORMATION FOR SEQ ID NO: 3:

## (i) SEQUENCE CHARACTERISTICS:

- (A) LENGTH: 717 base pairs
- (B) TYPE: nucleic acid
- (C) STRANDEDNESS: single
- (D) TOPOLOGY: linear

## (ix) FEATURE:

- (A) NAME/KEY: modified\_base
- (B) LOCATION:193
- (D) OTHER INFORMATION:/mod\_base= OTHER  
/note= "W = A or T"

## (ix) FEATURE:

- (A) NAME/KEY: modified\_base
- (B) LOCATION:195..196
- (D) OTHER INFORMATION:/mod\_base= OTHER  
/note= "Y = C or T"

## (xi) SEQUENCE DESCRIPTION: SEQ ID NO: 3:

ATGAGCAAGG GCGAGGAACT GTTCACTGGC GTGGTCCCAA TTCTCGTGGA ACTGGATGGC 60  
 GATGTGAATG GGCACAAATT TTCTGTCAGC GGAGAGGGTG AAGGTGATGC CACATACGGA 120  
 AAGCTCACCC TGAAATTCAT CTGCACCACT GGAAAGCTCC CTGTGCCATG GCCAACACTG 180

-106-

GTCACTACCT TCWCYYATGG CGTGEAGTGC TTTTCCAGAT ACCCAGACCA TATGAAGCAG 240  
 CATGACTTTT TCAAGAGCGC CATGCCCGAG GGCTATGTGC AGGAGAGAAC CATCTTTTTC 300  
 AAAGATGACG GGAACTACAA GACCCGCGCT GAAGTCAAGT TCGAAGGTGA CACCCTGGTG 360  
 AATAGAATCG AGTTGAAGGG CATTGACTTT AAGGAAGATG GAAACATTCT CGGCCACAAG 420  
 CTGGAATACA ACTATAACTC CCACAATGTG TACATCATGG CCGACAAGCA AAAGAATGGC 480  
 ATCAAGGTCA ACTTCAAGAT CAGACACAAC ATTGAGGATG GATCCGTGCA GCTGGCCGAC 540  
 CATTATCAAC AGAACACTCC AATCGGCGAC GGCCCTGTGC TCCTCCCAGA CAACCATTAC 600  
 CTGTCCACCC AGTCTGCCCT GTCTAAAGAT CCCAACGAAA AGAGAGACCA CATGGTCCTG 660  
 CTGGAGTTTG TGACCGCTGC TGGGATCACA CATGGCATGG ACGAGCTGTA CAAGTGA 717

## (2) INFORMATION FOR SEQ ID NO: 4:

- (i) SEQUENCE CHARACTERISTICS:  
 (A) LENGTH: 6 amino acids  
 (B) TYPE: amino acid  
 (C) STRANDEDNESS:  
 (D) TOPOLOGY: linear

## (xi) SEQUENCE DESCRIPTION: SEQ ID NO: 4:

Phe Ser Tyr Gly Val Gln  
 1 5

## (2) INFORMATION FOR SEQ ID NO: 5:

- (i) SEQUENCE CHARACTERISTICS:  
 (A) LENGTH: 6 amino acids  
 (B) TYPE: amino acid  
 (C) STRANDEDNESS:  
 (D) TOPOLOGY: linear

## (xi) SEQUENCE DESCRIPTION: SEQ ID NO: 5:

Met Gly Tyr Gly Val Leu  
 1 5

## (2) INFORMATION FOR SEQ ID NO: 6:

- (i) SEQUENCE CHARACTERISTICS:  
 (A) LENGTH: 8 amino acids  
 (B) TYPE: amino acid  
 (C) STRANDEDNESS:  
 (D) TOPOLOGY: linear

(xi) SEQUENCE DESCRIPTION: SEQ ID NO: 6:

Pro Pro Lys Lys Lys Arg Lys Val  
1 5

(2) INFORMATION FOR SEQ ID NO: 7:

- (i) SEQUENCE CHARACTERISTICS:
  - (A) LENGTH: 18 amino acids
  - (B) TYPE: amino acid
  - (C) STRANDEDNESS:
  - (D) TOPOLOGY: linear

(xi) SEQUENCE DESCRIPTION: SEQ ID NO: 7:

Met Leu Ser Leu Arg Gln Ser Ile Arg Phe Phe Lys Pro Ala Thr Arg  
1 5 10 15  
Thr Leu

(2) INFORMATION FOR SEQ ID NO: 8:

- (i) SEQUENCE CHARACTERISTICS:
  - (A) LENGTH: 12 base pairs
  - (B) TYPE: nucleic acid
  - (C) STRANDEDNESS: single
  - (D) TOPOLOGY: linear
- (ix) FEATURE:
  - (A) NAME/KEY: modified\_base
  - (B) LOCATION:7
  - (D) OTHER INFORMATION:/mod\_base= OTHER  
/note= "R = A or G"

(xi) SEQUENCE DESCRIPTION: SEQ ID NO: 8:

GCCGCCRCCA TG 12

(2) INFORMATION FOR SEQ ID NO: 9:

- (i) SEQUENCE CHARACTERISTICS:
  - (A) LENGTH: 45 base pairs
  - (B) TYPE: nucleic acid
  - (C) STRANDEDNESS: single
  - (D) TOPOLOGY: linear

(xi) SEQUENCE DESCRIPTION: SEQ ID NO: 9:

TGCTCTAGAG CGGCCGCCGC CACCATGAGC AAGGGCGAGG AACTG 45

-108-

## (2) INFORMATION FOR SEQ ID NO: 10:

- (i) SEQUENCE CHARACTERISTICS:
  - (A) LENGTH: 38 base pairs
  - (B) TYPE: nucleic acid
  - (C) STRANDEDNESS: single
  - (D) TOPOLOGY: linear

## (xi) SEQUENCE DESCRIPTION: SEQ ID NO: 10:

CGGAAGCTTG CGGCCGCTCA CTTGTACAGC TCGTCCAT 38

## (2) INFORMATION FOR SEQ ID NO: 11:

- (i) SEQUENCE CHARACTERISTICS:
  - (A) LENGTH: 54 base pairs
  - (B) TYPE: nucleic acid
  - (C) STRANDEDNESS: single
  - (D) TOPOLOGY: linear

## (xi) SEQUENCE DESCRIPTION: SEQ ID NO: 11:

GCTTCATATG GTCTGGGTAT CTGGAAAAGC ACTGCACGCC ATACCAGAAG GTAG 54

## (2) INFORMATION FOR SEQ ID NO: 12:

- (i) SEQUENCE CHARACTERISTICS:
  - (A) LENGTH: 54 base pairs
  - (B) TYPE: nucleic acid
  - (C) STRANDEDNESS: single
  - (D) TOPOLOGY: linear

## (xi) SEQUENCE DESCRIPTION: SEQ ID NO: 12:

GCTTCATATG GTCTGGGTAT CTGGAAAAGC ACTGCACGCC ATGAGAGAAG GTAG 54

## (2) INFORMATION FOR SEQ ID NO: 13:

- (i) SEQUENCE CHARACTERISTICS:
  - (A) LENGTH: 66 base pairs
  - (B) TYPE: nucleic acid
  - (C) STRANDEDNESS: single
  - (D) TOPOLOGY: linear

## (xi) SEQUENCE DESCRIPTION: SEQ ID NO: 13:

TGCTCTAGAG CGGCCGCCGC CACCATGGTG CCCAAGAAGA AGAGGAAGGT GATGAGCAAG 60

GGCGAG 66

## (2) INFORMATION FOR SEQ ID NO: 14:

## (i) SEQUENCE CHARACTERISTICS:

- (A) LENGTH: 5030 base pairs  
 (B) TYPE: nucleic acid  
 (C) STRANDEDNESS: single  
 (D) TOPOLOGY: linear

## (xi) SEQUENCE DESCRIPTION: SEQ ID NO: 14:

```

GGCCGGCTCTA GCTTGGGATC TTGTGAAGG AACCTTACTT CTGTGGTGTG ACATAATTGG      60
ACAAACTACC TACAGAGATT TAAAGCTCTA AGGTAAATAT AAAATTTTTA AGTGTATAAT      120
GTGTTAAACT AGCTGCATAT GCTTGTGCTGCT TGAGAGTTTT GCTTACTGAG TATGATTTAT      180
GAAAATATTA TACACAGGAG CTAGTGATTC TAATTGTTTG TGTATTTTAG ATTCACAGTC      240
CCAAAGSCTCA TTTCAGGCC CTCAGTCCCTC ACAGTCTGTT CATGATCATA ATCAGCCATA      300
CCACATTTGT AGAGTTTTA CTGTCTTTAA AAAACCTCCC ACACCTCCCC CTGAACCTGA      360
AACATAAAAT GAATGCAATT GTTGTGTGTTA ACTTGTTTAT TGCAGCTTAT AATGGTTACA      420
AATAAAGCAA TAGCATCACA AATTTCACAA ATAAAGCATT TTTTTCACCTG CATTCTAGTT      480
GTGGTTTGTG CAAACTCATC AATGTAICTT ATCATGCTCG GAICGATCCT GCATTAATGA      540
ATCGGCCAAC GCGGGGGAG AGCGGTTTG CGTATTGGCT GCGGTAATAG CGAAGAGGCC      600
CGCACCGATC GCCCTTCCCA ACAGTTGCGC AGCCTGAATG GCGAAITGGAC GCGCCCTGTA      660
CGCGGCGCATT AAGCGGGCG GGTGTGGTGG TTACGGCGCAG CGTGACCGCT ACACCTGCCA      720

```

- 110 -

GGCCCTAGC GCCCGCTCCT TTCGCTTCT TCCCTTCCCTT TCTCGCCACG TTCGCCGGCT 780  
TTCCCCGTC AACTCTAAT CGGGGCTCC CTTTAGGGTT CCGATTAGT GCTTTACGGC 840  
ACCTCGACC CAAAAAATT GATTAGGGTG ATGGTTCAG TAGTGGCCA TCGCCCTGAT 900  
AGACGGTTTT TCGCCCTTTG ACGTTGGAGT CCACGTTCTT TAATAGTGA CTCTTGTTC 960  
AACTGGAC AACACTCAAC CCTATCTCG TCTATTCTTT TGATTATAA GGGATTTIGC 1020  
CGATTCGGC CTATTGGTTA AAAAAAGAGC TGAFTTAACA AAAAATTAAC GCGAATTTTA 1080  
ACAAAATAIT AACGTTTACA ATTTCAGGTG GCACTTTTCG GGGAAAATGTG CGCGGAACCC 1140  
CTATTGTTTT ATTTTTCTAA ATACATTCAA ATATGTATCC GCTCATGCCA GGTCTTGGAC 1200  
TGGTGAGAC GGCTTGCTCG GCAGCTTGA TGTGTCTGG AGGGAGAATA AAGGTCTAAG 1260  
ATGTGCGATA GAGGGAAGTC GCATTGAATT ATGTGCTGTG TAGGGATCGC TGGTATCAAA 1320  
TATGTGTGCC CACCCCTGGC ATGAGACAAT AACCTGATA AATGCTTCAA TAATATTGAA 1380  
AAAGGAAGAG TATGAGTATT CAACATTTCC GTGTCGCCCT TATTCCTTTT TTTGCCGCAT 1440  
TTTGCCTCC TGTTTTTGCT CACCCAGAAA CGCTGGTAAA AGTAAAAGAT GCTGAAGATC 1500  
AGTTGGTGC ACGAGTGGGT TACATCGAAC TGGATCTCAA CAGCGGTAAG ATCCTTGAGA 1560  
GTTTTGCCC CGAAGAACGT TTTCCAAATGA TGAGCACTTT TAAAGTCTG CTATGTGGC 1620  
CGGTATTATC CCGTATTGAC GCCGGGCAAG AGCAACTCG TCGCCGCATA CACTATTCTC 1680  
AGAAAGACTT GGTGAGTAC TCACCAGTCA CAGAAAAGCA TCTTACGGAT GGCATGACAG 1740



TAAGAGAAAT ATGCAGTGCT GCCATAACCA TGAGTGATAA CACTGGGCC AACTTACTTC 1800  
TGACAAACGAT CGGAGGACCG AAGGAGCTAA CCGCTTTTTT GCACAACATG GGGGATCATG 1860  
TAACTCGCCT TGATCGTTGG GAACCGGAGC TGAATGAAGC CATACCAAAAC GACGAGCGTG 1920  
ACACCACGAT GCCTGTAGCA ATGGCAACAA CGTTGGCAA ACTATTAACT GCGCAACTAC 1980  
TTACTCTAGC TTCCCGGCAA CAATTAATAG ACTGGATGGA GCGGGATAAA GTTGCAGGAC 2040  
CACTTCTGCG CTCGGCCCTT CCGGCTGGCT GGTTTATTGC TGATAAATCT GGAGCCGCTG 2100  
AGCGTGGTC TCGCGGTATC ATTGCAGCAC TGGGGCCAGA TGGTAAGCCC TCCCCTATCG 2160  
TAGTTATCTA CACGACGGG AGTCAGGCAA CTATGGATGA ACGAAATAGA CAGATCGCTG 2220  
AGATAGGTGC CTCACTGATT AAGCATTGGT AACTGTCAGA CCAAGTTTAC TCATATATAC 2280  
TTTATGATGA TTTAAAACCT CATTTTTAAT TTAAAAGGAT CTAGGTGAAG ATCCTTTTTTG 2340  
ATAATCTCAT GCCATAACTT CGTATAATGT ATGCTATACG AAGTTATGGC ATGACCAAAA 2400  
TCCCTTAAACG TGAGTTTTTCG TTCCACTGAG CGTCAGACCC CGTAGAAAAG ATCAAAGGAT 2460  
CTTCTTGAGA TCCTTTTTTT CTGCGCGTAA TCTGCTGCTT GCAAAACAAA AAACCACCGC 2520  
TACCAGCGGT GGTTTGTGTTG CCGGATCAAG AGCTACCAAC TCTTTTTCCG AAGTAACTG 2580  
GCTTCAGCAG AGCGCAGATA CCAAATACTG TCCTTCTAGT GTAGCCGTAG TTAGGCCACC 2640  
ACTTCAAGAA CTCTGTAGCA CCGCCTACAT ACCTCGCTCT GCTAATCCTG TTACCAGTGG 2700  
CTGCTGCCAG TGGCGATAAG TCGTGTCTTA CCGGGTTGGA CTCGAAGACGA TAGTTACCGG 2760

ATAAGGCGCA GCGGTCGGGC TGAACGGGG GTTCGTGCAC ACAGCCCAGC TTGGAGCGAA 2820  
 CGACCTACAC CGAACTGAGA TACCTACAGC GTGAGCATTG AGAAAGCGCC ACGCTTCCCG 2880  
 AAGGAGAAA GCGGACACAGG TATCCGGTAA GCGGCAGGGT CGGAACAGGA GAGCGCACGA 2940  
 GGGAGCTTCC AGGGGAAAAC GCCTGGTATC TTTATAGTCC TGTGGGTTT CGCCACCCTCT 3000  
 GACTTGAGCG TCGATTTTGT TGATGCTCGT CAGGGGGGG GAGCCTATGG AAAAACGCCA 3060  
 GCAACGGGC CTTTTTACGG TTCCCTGGCCT TTTGCTGGCC TTTTGTCTAC ATGTTCTTTT 3120  
 CTGCGTTATC CCCTGATTCT GTGGATAACC GTATTACCGC CTTTGAGTGA GCTGATAACG 3180  
 CTCGCCGAG CCGAACGACC GAGCCAGCG AGTCAGTGAG CGAGGAAGCG GAAGAGCGCC 3240  
 CAATACGCA ACCGCCTCTC CCCGGCGGTT GGCCGATTCA TTAATGCAGA GCTTGCAATT 3300  
 CGCGGTTTT TCAATATTAT TGAAGCATTT ATCAGGGTTA TTGTCTCATG AGCGGATACA 3360  
 TATTTGAATG TATTTAGAAA AATAAACAAA TAGGGGTTC GCGCACATTT CCCCCAAAAG 3420  
 TGCCACCTGA CGTCTAAGAA ACCATTATTA TCATGACATT AACCTATAAA AATAGGCGTA 3480  
 TACGAGGCC TTTCACCTCAT TAGGCACCCC AGGCITTACA CTTTATAGCT TCCGGCTCGT 3540  
 ATAATGTGTG GAATTTGTAG CGGATAACAA TTTCACACAG GAAACAGCAT CGTGCAGGTC 3600  
 GTTACATAAC TTACGGTAAA TGGCCCGCCT GGCTGACCGC CCAACGACCC CCGCCCCATTG 3660  
 ACGTCAATAA TGACGTATGT TCCCATAGTA ACGCCAATAG GGACTTTCCA TTGACGTCAA 3720  
 TGGGTGGAGT ATTTACGGTA AACTGCCAC TTGGCAGTAC ATCAAGTGTA TCATATGCCA 3780

-113-

AGTAGGCCCC CTATTGACGT CAATGACGGT AAATGGCCCG CTTGGCAFTA TGCCAGTAC 3840  
ATGACCTTAT GGGACTTTCC TACTTGGCAG TACATCTACG TATTAGTCAAT CGCTATTACC 3900  
ATGGTGATGC GGTTTTGGCA GTACATCAAT GGGCGTGGAT AGCGGTTTGA CTCACGGGGA 3960  
TTTCCAAGTC TCCACCCCAT TGACGTCAAT GGGAGTTTGT TTTGGCACCA AAATCAACGG 4020  
GACTTTCCAA AATGTCGTAA CAACTCCGCC CCAATTGACGC AAATGGGCGG TAGGCGTGTA 4080  
CGGTGGGAGG TCTATATAAG CAGAGCTCGT TTAGTGAACC GTCAGATCGC CTGGAGACGC 4140  
CATCCACGCT GTTTTGACCT CCATAGAAGA CACCGGGACC GATCCAGCCT CCGGACTCTA 4200  
GCCTAGGCTT TTGCAAAAAG CTATTTAGGT GACACTATAG AAGGTACGCC TGCAGGTACC 4260  
GGTCCGGAAT TCCCGGGTCC ACGAGCTCAC TAGTCGGCGG CCGCCGCCAC CATGAGCAAG 4320  
GGCGAGGAAC TGTTCACCTG CGTGGTCCCA ATTCTCGTGG AACTGGATGG CGATGTGAAT 4380  
GGGCACAAAT TTTCTGTGAG CGGAGAGGSET GAAGGTGATG CCACATACGG AAAGCTCACC 4440  
CTGAAATTCA TCTGCACCAC TGGAAAGCTC CCTGTGCCAT GGCCAACACT GGTCACACTACC 4500  
TTCACCTATG GCGTGCAGTG CTTTTCCAGA TACCCAGACC ATATGAAGCA GCATGACTTT 4560  
TTCAAGAGCG CCAATGCCCGA GGGCTATGTG CAGGAGAGAA CCATCTTTTT CAAAAGATGAC 4620  
GGGAACTACA AGACCCGCGC TGAAGTCAAG TTCGAAGGTG ACACCCCTGGT GAATAGAATC 4680  
GAGTTGAAGG GCATTGACTT TAAGGAAGAT GGAACAATTC TCGGCCACAA GCTGGAATAC 4740  
AACTATAACT CCCACAATGT GTACATCATG GCCGACAAGC AAAAGAATGG CATCAAGGTC 4800

-114-

AAC TTCAAGA TCAGACACAA CATTGAGGAT GGATCCGTGC AGCTGGCCGA CCATTATCAA 4860  
CAGAACA CTC CAATCGGCGA CGGCCCTGTG CTCCTCCCAG ACAACCATTA CCTGTCCACC 4920  
CAGTCTGCC TGTCTAAGA TCCCAACGAA AAGAGAGACC ACATGGTCCT GCTGGAGTTT 4980  
GTGACCGCTG CTGGGATCAC ACATGGCATG GACGAGCTGT ACAAGTGAGC 5030

**CLAIMED:**

1. A humanized green fluorescent protein (GFP) gene.
- 5 2. The humanized GFP gene of claim 1, wherein said gene encodes a green fluorescent protein that has the amino acid sequence of SEQ ID NO:2.
- 10 3. The humanized GFP gene of claim 1, wherein said gene encodes a green fluorescent protein that has the amino acid sequence of SEQ ID NO:2 in which Serine at position 65 has been replaced by Threonine.
- 15 4. The humanized GFP gene of claim 1, wherein said gene encodes a green fluorescent protein that has the amino acid sequence of SEQ ID NO:2 in which Tyrosine at position 66 has been replaced by Histidine.
- 20 5. The humanized GFP gene of claim 1, wherein said gene encodes a green fluorescent protein that has the amino acid sequence of SEQ ID NO:2 in which the chromophore sequence Phe Ser Tyr Gly Val Gln (SEQ ID NO:4) between positions 64 and 69 has been replaced by the sequence Met Gly Tyr Gly Val Leu (SEQ ID NO:5).
- 25 6. The humanized GFP gene of claim 1, wherein at least about 10% of said codon positions contain a humanized codon.
- 30

-116-

7. The humanized GFP gene of claim 6, wherein at least about 15% of said codon positions contain a humanized codon.
- 5 8. The humanized GFP gene of claim 7, wherein at least about 20% of said codon positions contain a humanized codon.
9. The humanized GFP gene of claim 8, wherein at least about 25% of said  
10 codon positions contain a humanized codon.
10. The humanized GFP gene of claim 9, wherein at least about 30% of said codon positions contain a humanized codon.  
15
11. The humanized GFP gene of claim 10, wherein at least about 35% of said codon positions contain a humanized codon.  
20
12. The humanized GFP gene of claim 11, wherein at least about 50% of said codon positions contain a humanized codon.
- 25 13. The humanized GFP gene of claim 1, wherein said gene comprises at least seven humanized codons from the 10 codons located at codon positions 18, 53, 93, 125, 150, 178, 195, 208, 236 and 224 of the GFP gene sequence.

-117-

14. The humanized GFP gene of claim 13, wherein said gene comprises at least eight humanized codons from the 10 codons located at codon positions 18, 53, 93, 125, 150, 178, 195, 208, 236 and 224 of the GFP gene sequence.

5

15. The humanized GFP gene of claim 14, wherein said gene comprises at least nine humanized codons from the 10 codons located at codon positions 18, 53, 93, 125, 150, 178, 195, 208, 236 and 224 of the GFP gene sequence.

10

16. The humanized GFP gene of claim 15, wherein said gene comprises a humanized codon at each of the codon positions 18, 53, 93, 125, 150, 178, 195, 208, 236 and 224 of the GFP gene sequence.

15

17. The humanized GFP gene of claim 13, wherein said gene comprises any one of the humanized Leucine codons CTG, CTC or TTG at codon positions 18, 53, 125, 178, 195 and 236 of the GFP gene sequence.

20

18. The humanized GFP gene of claim 13, wherein said gene comprises the humanized Valine codon GTG at codon positions 93, 150 and 224 of the GFP gene sequence.

25

19. The humanized GFP gene of claim 13, wherein said gene comprises the humanized Serine codon TCT at codon position 208 of the GFP gene sequence.

20. The humanized GFP gene of claim 1, wherein said gene comprises an increased number of GCC or GCT Alanine-encoding codons within the coding region in comparison to the wild type jellyfish gene sequence of SEQ ID NO:1.
- 5
21. The humanized GFP gene of claim 1, wherein said gene comprises an increased number of TGC Cysteine-encoding codons within the coding region in comparison to the wild type jellyfish gene sequence of SEQ ID NO:1.
- 10
22. The humanized GFP gene of claim 1, wherein said gene comprises an increased number of GAC Aspartate-encoding codons within the coding region in comparison to the wild type jellyfish gene sequence of SEQ ID NO:1.
- 15
23. The humanized GFP gene of claim 1, wherein said gene comprises an increased number of GAG Glutamate-encoding codons within the coding region in comparison to the wild type jellyfish gene sequence of SEQ ID NO:1.
- 20
24. The humanized GFP gene of claim 1, wherein said gene comprises an increased number of TTC Phenylalanine-encoding codons within the coding region in comparison to the wild type jellyfish gene sequence of SEQ ID NO:1.
- 25
25. The humanized GFP gene of claim 1, wherein said gene comprises an increased number of GGC Glycine-encoding codons within the coding region in comparison to the wild type jellyfish gene sequence of SEQ ID NO:1.



26. The humanized GFP gene of claim 1, wherein said gene comprises an increased number of CAC Histidine-encoding codons within the coding region in comparison to the wild type jellyfish gene sequence of SEQ ID NO:1.

5

27. The humanized GFP gene of claim 1, wherein said gene comprises an increased number of ATC Isoleucine-encoding codons within the coding region in comparison to the wild type jellyfish gene sequence of SEQ ID NO:1.

10

28. The humanized GFP gene of claim 1, wherein said gene comprises an increased number of AAG Lysine-encoding codons within the coding region in comparison to the wild type jellyfish gene sequence of SEQ ID NO:1.

15

29. The humanized GFP gene of claim 1, wherein said gene comprises an increased number of CTG or CTC Leucine-encoding codons within the coding region in comparison to the wild type jellyfish gene sequence of SEQ ID NO:1.

20

30. The humanized GFP gene of claim 1, wherein said gene comprises an increased number of AAC Asparagine-encoding codons within the coding region in comparison to the wild type jellyfish gene sequence of SEQ ID NO:1.

25

31. The humanized GFP gene of claim 1, wherein said gene comprises an increased number of CCC or CCT Proline-encoding codons within the coding region in comparison to the wild type jellyfish gene sequence of SEQ ID NO:1.

30

32. The humanized GFP gene of claim 1, wherein said gene comprises an increased number of CAG Glutamine-encoding codons within the coding region in comparison to the wild type jellyfish gene sequence of SEQ ID NO:1.

5

33. The humanized GFP gene of claim 1, wherein said gene comprises an increased number of CGC, AGG or CGG Arginine-encoding codons within the coding region in comparison to the wild type jellyfish gene sequence of SEQ ID NO:1.

10

34. The humanized GFP gene of claim 1, wherein said gene comprises an increased number of AGC or TCC Serine-encoding codons within the coding region in comparison to the wild type jellyfish gene sequence of SEQ ID NO:1.

15

35. The humanized GFP gene of claim 1, wherein said gene comprises an increased number of ACC Threonine-encoding codons within the coding region in comparison to the wild type jellyfish gene sequence of SEQ ID NO:1.

20

36. The humanized GFP gene of claim 1, wherein said gene comprises an increased number of GTG or GTC Valine-encoding codons within the coding region in comparison to the wild type jellyfish gene sequence of SEQ ID NO:1.

25

37. The humanized GFP gene of claim 1, wherein said gene comprises an increased number of TAC Tyrosine-encoding codons within the coding region in comparison to the wild type jellyfish gene sequence of SEQ ID NO:1.

30

38. The humanized GFP gene of claim 1, wherein said gene comprises a TGA termination codon.

5

39. The humanized GFP gene of claim 1, wherein said gene comprises a decreased number of GCA Alanine-encoding codons within the coding region in comparison to the wild type jellyfish gene sequence of SEQ ID NO:1.

10

40. The humanized GFP gene of claim 1, wherein said gene comprises a decreased number of GGU Glycine-encoding codons within the coding region in comparison to the wild type jellyfish gene sequence of SEQ ID NO:1.

15

41. The humanized GFP gene of claim 1, wherein said gene comprises a decreased number of CTT, CTA or TTA Leucine-encoding codons within the coding region in comparison to the wild type jellyfish gene sequence of SEQ ID NO:1.

20

42. The humanized GFP gene of claim 1, wherein said gene comprises a decreased number of AGA Arginine-encoding codons within the coding region in comparison to the wild type jellyfish gene sequence of SEQ ID NO:1.

25

43. The humanized GFP gene of claim 1, wherein said gene comprises a decreased number of AGT, TCA or TCG Serine-encoding codons within the coding region in comparison to the wild type jellyfish gene sequence of SEQ ID NO:1.

30

44. The humanized GFP gene of claim 1, wherein said gene comprises a decreased number of GTT or GTA Valine-encoding codons within the coding region in comparison to the wild type jellyfish gene sequence of SEQ ID NO:1.

5

45. The humanized GFP gene of claim 1, wherein said gene is operatively positioned downstream from a Kozak consensus sequence.

10

46. The humanized GFP gene of claim 1, wherein said gene comprises the nucleic acid sequence of SEQ ID NO:3.

15

47. The humanized GFP gene of claim 1, wherein said gene is operatively linked to protein-encoding nucleic acid sequence.

20

48. The humanized GFP gene of claim 1, wherein said gene is positioned under the transcriptional control of a promoter operative in a mammalian cell.

25

49. The humanized GFP gene of claim 48, further defined as a recombinant vector.

30

50. An expression vector comprising a humanized GFP reporter gene operatively positioned downstream from a promoter, the promoter directing expression of the humanized GFP gene in a mammalian cell.

51. The expression vector of claim 50, wherein said promoter is a constitutive promoter.

5

52. The expression vector of claim 50, wherein said promoter is a viral promoter.

53. The expression vector of claim 50, wherein said promoter is a HSV, TK, RSV, SV40, CMV or  $\beta$ -actin promoter.

10

54. The expression vector of claim 53, wherein said promoter is a CMV promoter.

15

55. The expression vector of claim 50, wherein said promoter is an inducible promoter.

20

56. The expression vector of claim 55, wherein said promoter is a cytochrome P450, heat shock protein, metallothionein or estrogen gene promoter, a radiation-inducible promoter or a tetVP16 promoter.

25

57. The expression vector of claim 50, wherein said promoter is a tissue-specific promoter.

30

58. The expression vector of claim 57, wherein said promoter is a FAB, insulin, transphyretin,  $\alpha$ 1-antitrypsin, PAI-1, apolipoprotein AI, LDL receptor, MBP, GFAP, OPSIN or NSE gene promoter.

59. The expression vector of claim 50, wherein said expression vector further comprises a multiple cloning site.

5

60. The expression vector of claim 59, wherein said expression vector comprises a multiple cloning site operatively positioned between said promoter and said humanized GFP gene.

10

61. The expression vector of claim 59, wherein said expression vector comprises a multiple cloning site operatively positioned downstream from said humanized GFP gene.

15

62. The expression vector of claim 50, wherein said expression vector further comprises an IRES element.

20

63. The expression vector of claim 50, wherein said expression vector further comprises a second reporter gene.

25

64. The expression vector of claim 63, wherein said second reporter gene is comprised within a second transcriptional unit.

30

65. The expression vector of claim 63, wherein said second reporter gene confers resistance to neomycin, hygromycin, puromycin, zeocin, mycophenolic acid, histidinol or methotrexate.

- 5 66. The expression vector of claim 50, wherein said expression vector further comprises a polyadenylation signal.
- 10 67. The expression vector of claim 50, wherein said expression vector is a recombinant adenoviral vector.
- 15 68. The expression vector of claim 50, wherein said expression vector is a recombinant adeno-associated viral (AAV) vector.
- 20 69. The expression vector of claim 50, wherein said expression vector is a recombinant retroviral vector.
70. The expression vector of claim 50, wherein said expression vector comprises a humanized GFP reporter gene that has the nucleic acid sequence of SEQ ID NO:3.
- 25 71. The expression vector of claim 50, wherein said expression vector expresses an enhanced green or enhanced blue fluorescent protein.
72. A recombinant host cell comprising a humanized GFP gene.

73. The recombinant host cell of claim 72, wherein said humanized GFP gene is introduced into said cell by means of a recombinant vector.
- 5 74. The recombinant host cell of claim 73, wherein said cell expresses said humanized GFP gene to produce the encoded GFP protein.
75. The recombinant host cell of claim 72, wherein said cell is a mammalian cell.  
10
76. The recombinant host cell of claim 72, wherein said cell is a human cell.
- 15 77. The recombinant host cell of claim 72, wherein said cell is a VERO, HeLa, CHO, COS, W138, BHK, HepG2, 3T3, RIN, MDCK, A549, PC12, K562 or 293 cell.
78. The recombinant host cell of claim 72, wherein said cell is a cell of a primary  
20 cell line.
79. The recombinant host cell of claim 72, wherein said cell is located within a  
25 mammal.
80. The recombinant host cell of claim 72, wherein said cell comprises a  
humanized GFP gene that comprises the nucleic acid sequence of SEQ ID NO:3.  
30



-127-

81. The recombinant host cell of claim 72, wherein said cell further comprises a recombinant gene that expresses a desired protein.

5 82. A reporter gene expression kit comprising, in suitable container means, an expression vector comprising a humanized GFP gene.

83. A method of labeling a mammalian cell, comprising expressing a humanized  
10 GFP gene in said cell.

84. A method of identifying a mammalian cell within a population of cells,  
comprising the steps of:

15

(a) expressing a humanized GFP gene in said cell;

(b) admixing said cell with a population of cells that do not express GFP;  
and

20

(c) identifying said cell by identifying a GFP-fluorescent cell.

85. A method of identifying a mammalian cell that contains an exogenous DNA  
25 segment, comprising the steps of:

(a) introducing into said cell an expression vector comprising a humanized  
GFP gene operatively linked to an exogenous DNA segment; and

-128-

- (b) identifying a cell containing said exogenous DNA segment by identifying a GFP-fluorescent cell.

5 86. The method of claim 85, wherein said expression vector comprises a first coding region encoding GFP and a second coding region comprising said exogenous DNA segment.

10 87. The method of claim 85, wherein said exogenous DNA segment encodes an untranslated product.

88. The method of claim 85, wherein said exogenous DNA segment encodes a selected protein or peptide.

15

89. The method of claim 88, wherein said expression vector comprises a first coding region encoding a fusion protein comprising GFP operatively linked to said selected protein or peptide.

20

90. The method of claim 89, wherein said fusion protein comprises GFP operatively linked to a peptide that comprises a sub-cellular localization signal.

25

91. The method of claim 90, wherein said fusion protein comprises GFP operatively linked to a selected protein and to a peptide that comprises a sub-cellular localization signal.

30

-129-

92. The method of claim 90, wherein said fusion protein comprises GFP linked to a nuclear targeting peptide.
- 5 93. The method of claim 90, wherein said fusion protein comprises GFP linked to a mitochondrial targeting peptide.
94. The method of claim 85, wherein said cell comprises a first and second  
10 humanized GFP gene, each expressing a GFP protein with different spectral properties.
95. The method of claim 85, wherein said cell is a human cell.
- 15 96. The method of claim 85, wherein a GFP-fluorescent cell is identified by fluorescence activated cell sorting.
- 20 97. The method of claim 85, wherein said cell is located within a mammal.
98. A method of determining the location of a selected protein within a mammalian cell, comprising the steps of:
- 25 (a) introducing into said cell an expression vector comprising a contiguous DNA sequence comprising a humanized GFP gene operatively linked to a gene encoding said selected protein; and

-130-

- (b) identifying the location of the selected protein within the cell by identifying the location of the GFP fluorescence.

5 99. The method of claim 98, wherein the location of said selected protein within said cell is dependent upon external stimuli.

10 100. The method of claim 98, wherein the location of said selected protein within said cell is dependent upon the cell cycle.

15 101. A method of targeting a protein to a selected location within a mammalian cell, comprising the steps of:

- (a) introducing into said cell an expression vector comprising a contiguous DNA sequence comprising a sequence encoding a targeting peptide operatively linked to humanized GFP gene and protein-encoding gene; and

20

- (b) confirming the selected location of the protein within the cell by identifying the location of the GFP fluorescence.

25 102. A method of testing a candidate promoter in a mammalian cell, comprising the steps of:

- (a) introducing into said cell an expression vector comprising a humanized GFP gene under the control of said candidate promoter;

30

-131-

- (b) maintaining said cell under conditions effective and for a period of time sufficient to allow expression of said humanized GFP gene by said candidate promoter; and
- 5 (c) identifying a GFP-fluorescent cell, wherein the presence of a GFP-fluorescent cell is indicative of an active promoter.

103. The method of claim 102, wherein said candidate promoter is a candidate tissue-specific promoter.

10

104. The method of claim 102, wherein said candidate promoter is a candidate inducible promoter.

15

105. The method of claim 102, wherein said candidate promoter is naturally associated with a candidate gene that is being tested for expression in a mammalian cell.

20

106. The method of claim 102, wherein said cell is located within a mammal.

25 107. A method of detecting a substance that stimulates transcription from a selected promoter in a mammalian cell, comprising the steps of:

- (a) introducing into a mammalian cell an expression vector comprising a humanized GFP gene under the control of said selected promoter;
- 30

-132-

- (b) exposing said cell to a composition suspected of containing said substance; and
- (c) identifying a GFP-fluorescent cell, wherein the presence of a GFP-fluorescent cell is indicative of the presence of a substance that stimulates transcription from said selected promoter.

5

108. The method of claim 107, wherein said substance is a toxin or a pollutant.

10

109. A method for determining the expression level of a selected gene in a mammal, comprising the steps of:

15

- (a) expressing in the cells of said mammal an expression vector comprising a humanized GFP gene operatively linked to a selected gene; and

20

- (b) determining the GFP fluorescence in the cells of said mammal, wherein the level of GFP fluorescence is indicative of the expression level of said selected gene.

25

110. A method for analyzing the expression of a selected gene in different tissues of a mammal, comprising the steps of:

- (a) introducing into the cells of said mammal an expression vector comprising said selected gene under the control of the natural gene promoter, said gene operatively linked to a humanized GFP gene;

30

-133-

- (b) maintaining said mammal under conditions effective and for a period of time sufficient to allow expression of said gene; and
- (c) analyzing cells of the tissues of said mammal, wherein the presence of GFP-fluorescent cells in a given tissue is indicative of gene expression in said tissue.

111. A method of using a humanized GFP gene, comprising expressing a humanized GFP gene in a mammalian host cell and collecting the GFP expressed by said cell.

112. The method of claim 111, wherein said humanized GFP gene is fused to a DNA sequence encoding a protein or peptide of known molecular weight and wherein said host cell expresses a GFP fusion protein.

113. The humanized GFP gene of claim 4 wherein said gene encodes a blue fluorescent protein that has the amino acid sequence of SEQ ID NO:2 in which tyrosine at position 145 is replaced by phenylalanine.

114. The humanized GFP gene of claim 1 wherein TAT encoding tyrosine at position 66 of amino acid sequence SEQ ID NO:2 is replaced by CAT and TAT encoding tyrosine at position 145 of amino acid SEQ ID NO:2 is replaced by TTC.

115. The humanized GFP gene of claim 1 wherein said gene encodes a green fluorescent protein that has the amino acid sequence of SEQ ID NO:2 in which phenylalanine at position 64 is replaced by leucine and serine at position 65 is replaced by threonine.

30

116. The humanized GFP gene of claim 1 wherein TTC encoding phenylalanine at position 64 of amino acid sequence SEQ ID NO:2 is replaced by CTG and TCT encoding serine at position 65 is replaced by ACC.



```

M  S  K  G  E  E  L  F  T  G  V  V  P  I  L  V  E  L  D  G
ATG AGT AAA GGA GAA GAA CTT TTC ACT GGA GTT GTC CCA ATT CTT GTT GAA TTA GAT GGT
C  G  C  G  G  C  G  C  G  C  G  C  G  C  G  C  G  C  G  C

10

D  V  N  G  H  K  F  S  V  S  G  E  G  E  G  D  A  T  Y  G
GAT GTT AAT GGG CAC AAA TTT TCT GTC AGT GGA GAG GGT GAA GGT GAT GCA ACA TAC GGA
G  G  C  C  C  C  C  C  C  C  C  C  C  C  C  C  C  C  C

30

K  L  T  L  K  F  I  C  T  G  K  L  P  V  P  W  P  T  L
AAA CTT ACC CTT AAA TTT ATT TGC ACT ACT GGA AAA CTA CCT GTT CCA TGG CCA ACA CTT
G  C  G  C  C  C  C  C  C  C  G  C  G  G  G  EaeI  G

60

V  T  T  F  S/T  Y/H  G  V  Q  C  F  S  R  Y  P  D  H  M  K  Q
GTC ACT ACT TTC TCT TAT GGT GTT CAA TGC TTT TCA AGA TAC CCA GAT CAT ATG AAA CAG
C  C  C  C  C  C  C  C  C  C  C  C  C  C  C  C  C  C

80

H  D  F  F  K  S  A  M  P  E  G  Y  V  Q  E  R  T  I  F  F
CAT GAC TTT TTC AAG AGT GCC ATG CCC GAA GGT TAT GTA CAG GAA AGA ACT ATA TTT TTC
C  C  C  C  C  C  C  C  C  C  G  G  G  C  C  C  C

100

K  D  D  G  N  Y  K  T  R  A  E  V  K  F  E  G  D  T  L  V
AAA GAT GAC GGG AAC TAC AAG ACA CGT GCT GAA GTC AAG TTT GAA GGT GAT ACC CTT GTT
C  C  C  C  C  C  C  C  C  C  C  C  C  C  C  C  C  C

120

```

FIG. 1.A-1

130 N R I E L K G I D F K E D G N I L G H K  
 AAT AGA ATC GAG TTA AAA GGT ATT GAT TTT AAA GAA GAT GGA AAC ATT CTT GGA CAC AAA  
 G G C C G

140  
 150 L E Y N Y N S H N V Y I M A D K Q K N G  
 TTG GAA TAC AAC TAT AAC TCA CAC AAT GTA TAC ATC ATG GCA GAC AAA CAA AAG AAT GGA  
 C C G

160  
 170 I K V N F K I R H N I E D G S V Q L A D  
 ATC AAA GTT AAC TTC AAA ATT AGA CAC AAC ATT GAA GAT GGA AGC GTT CAA CTA GCA GAC  
 G C G C G BAmHI T C G G C

180  
 190 H Y Q Q N T P I G D G P V L L P D N H Y  
 CAT TAT CAA CAA AAT ACT CCA ATT GGC GAT GGC CCT GTC CTT TTA CCA GAC AAC CAT TAC  
 G C C C C C C

200  
 210 L S T Q S A L S K D P N E K R D H M V L  
 CTG TCC ACA CAA TCT GCC CTT TCG AAA GAT CCC AAC GAA AAG AGA GAC CAC ATG GTC CTT  
 C G G T G C C

220  
 230 L E F V T A A G I T H G M D E L Y K  
 CTT GAG TTT GTA ACA GCT GCT GGG ATT ACA CAT GGC ATG GAT GAA CTA TAC AAA TAA  
 G C C C G G G G

FIG. 1.A-2

3/18

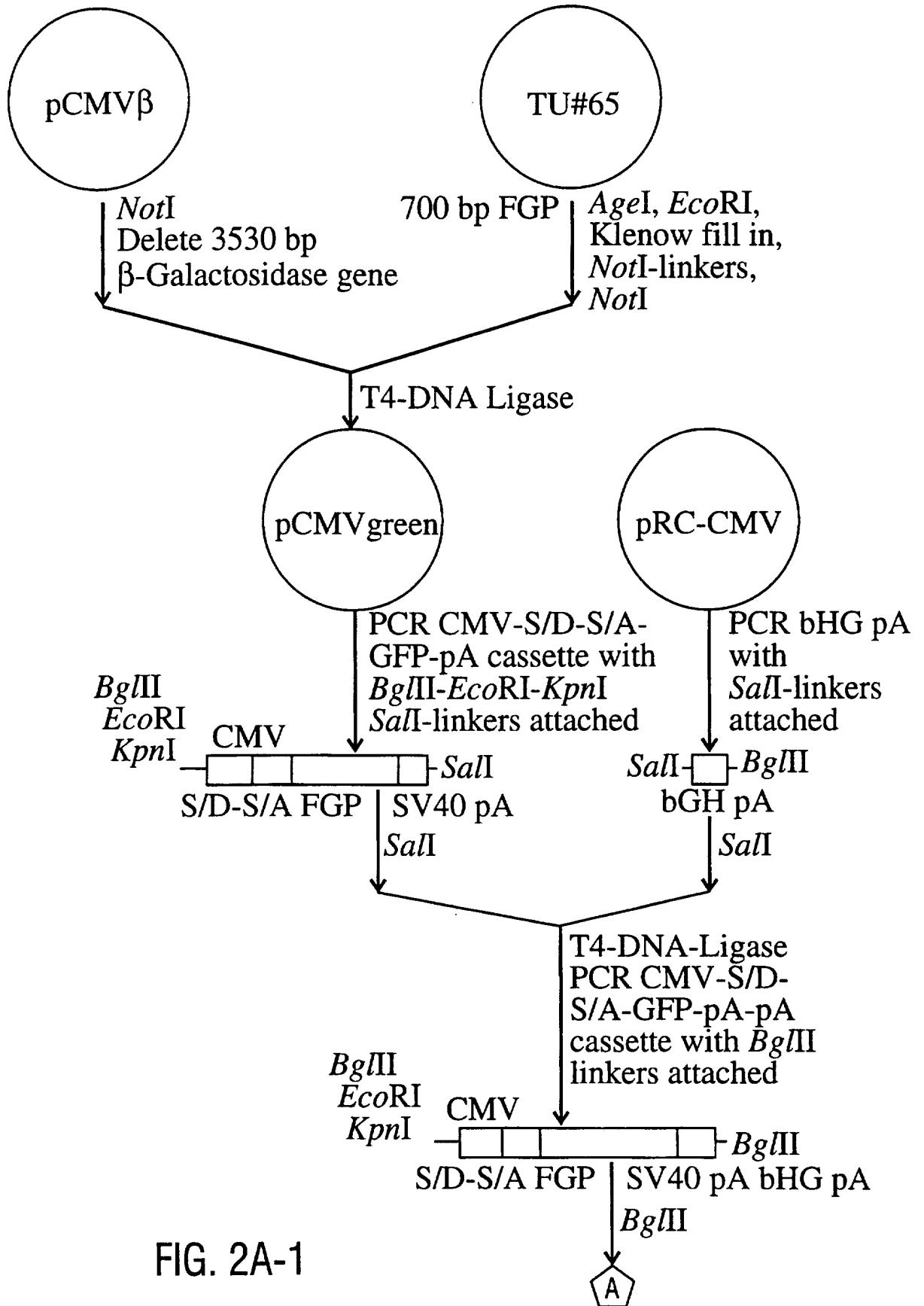

FIG. 2A-1

4/18

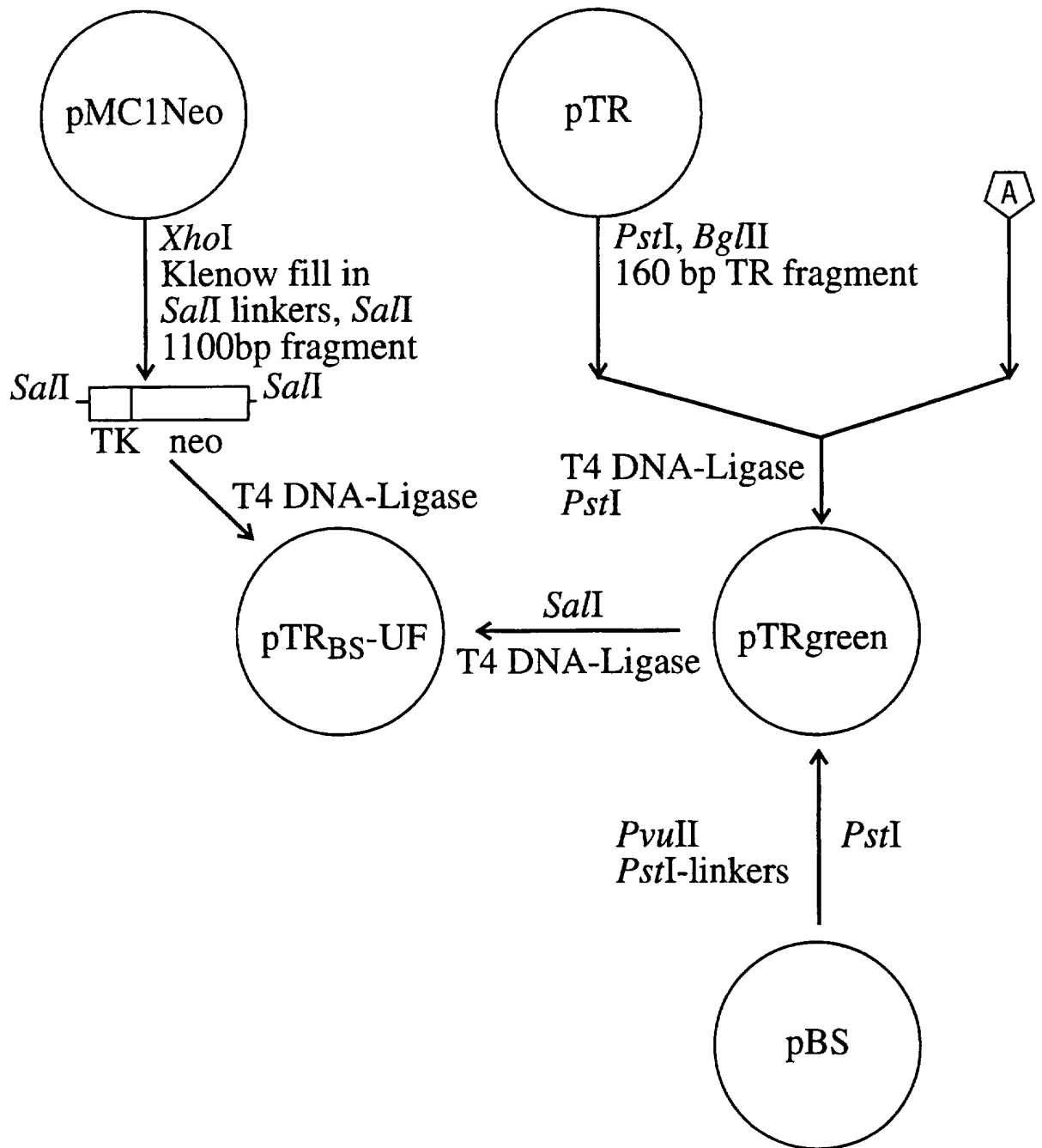
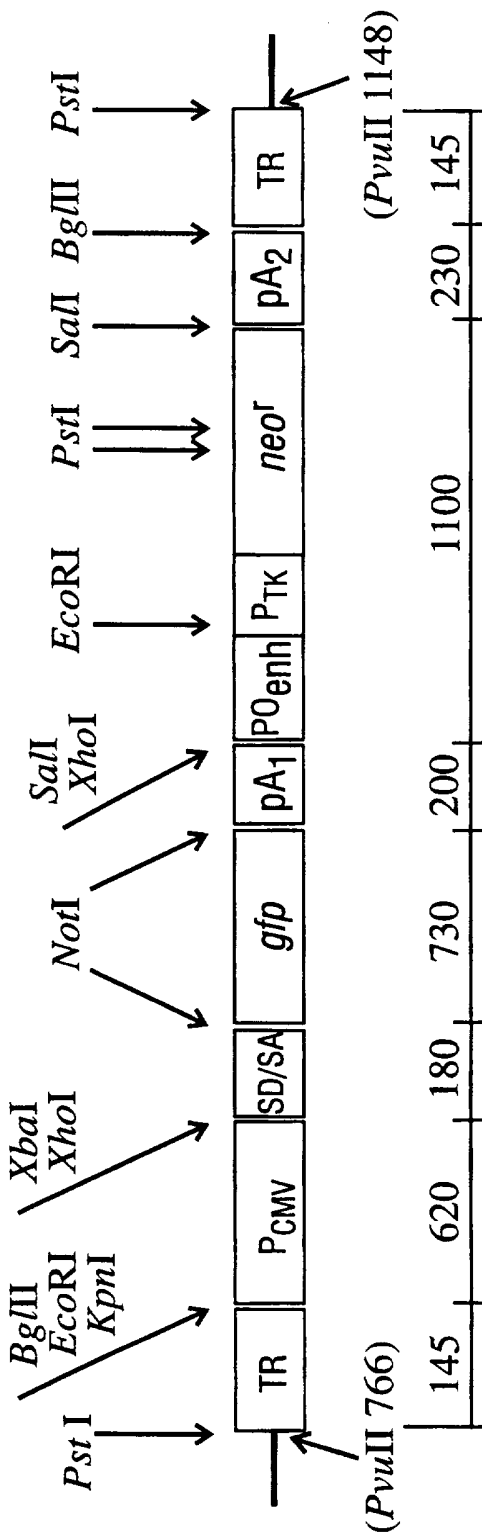

FIG. 2A-2

pTR<sub>BS</sub>-UF/UF1/UF2/UFB



3.4 kbp AAV cassette

FIG. 2B-1

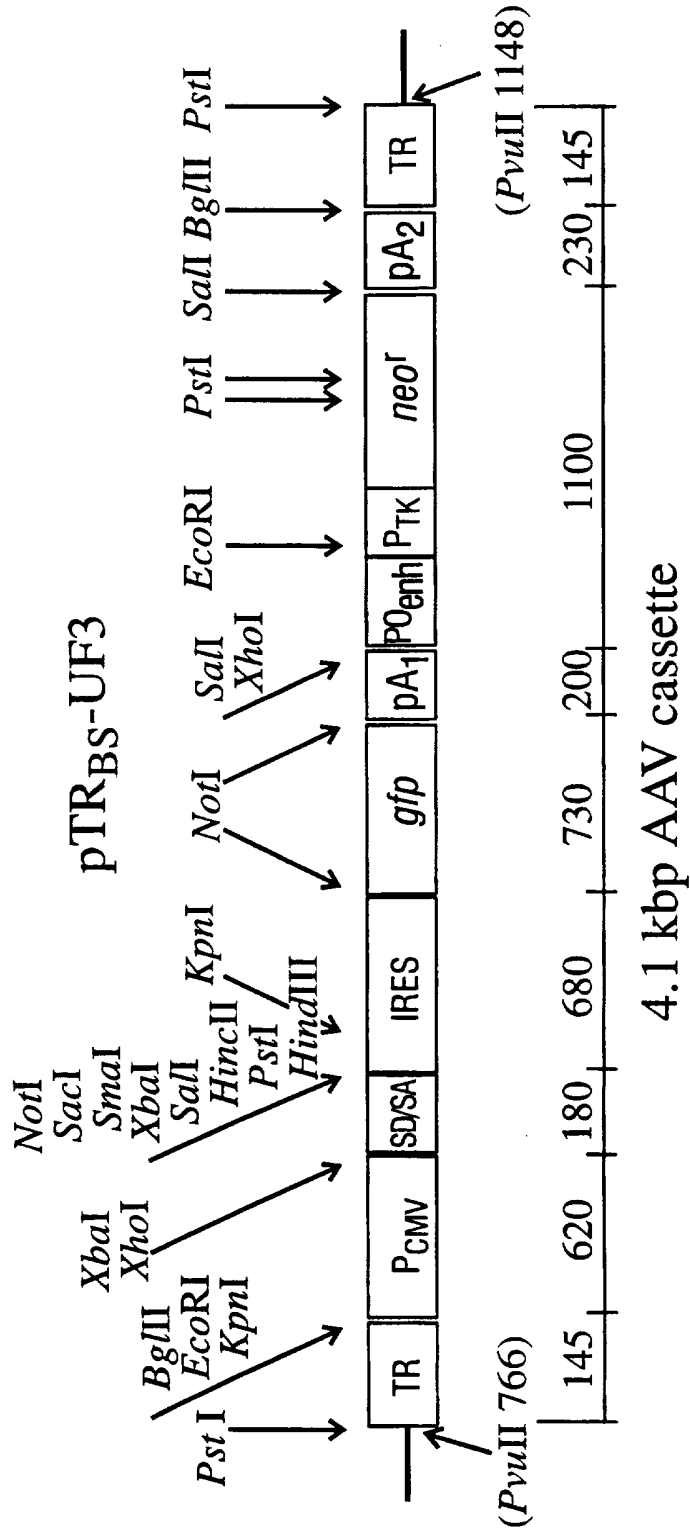

FIG. 2B-2

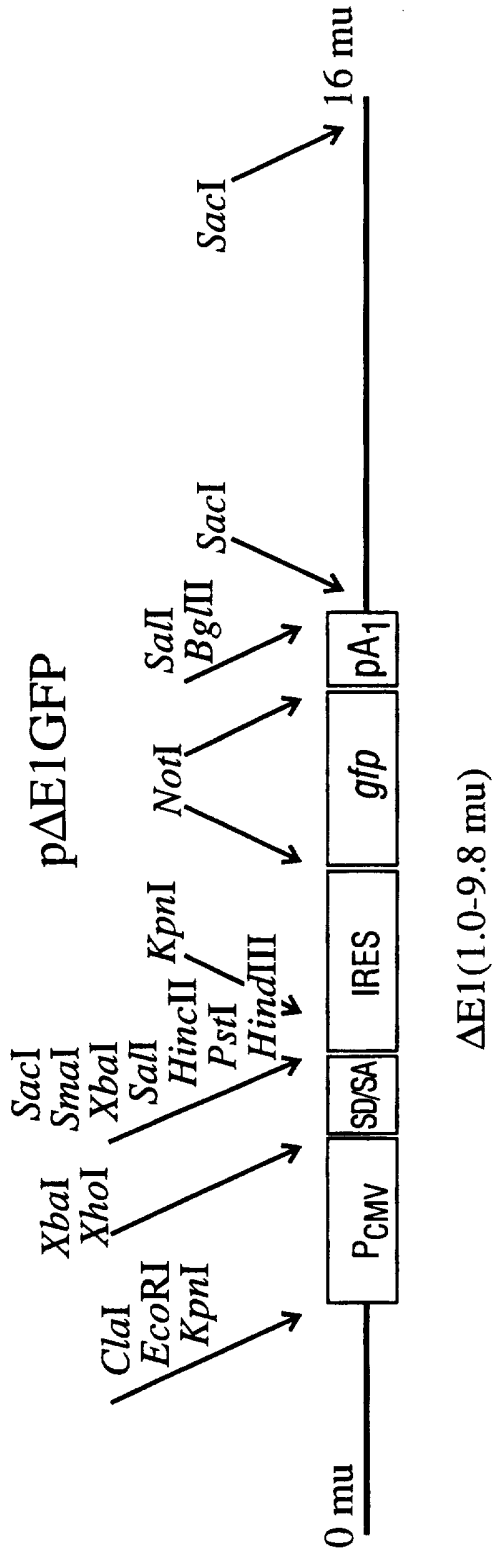

FIG. 2B-3

8/18

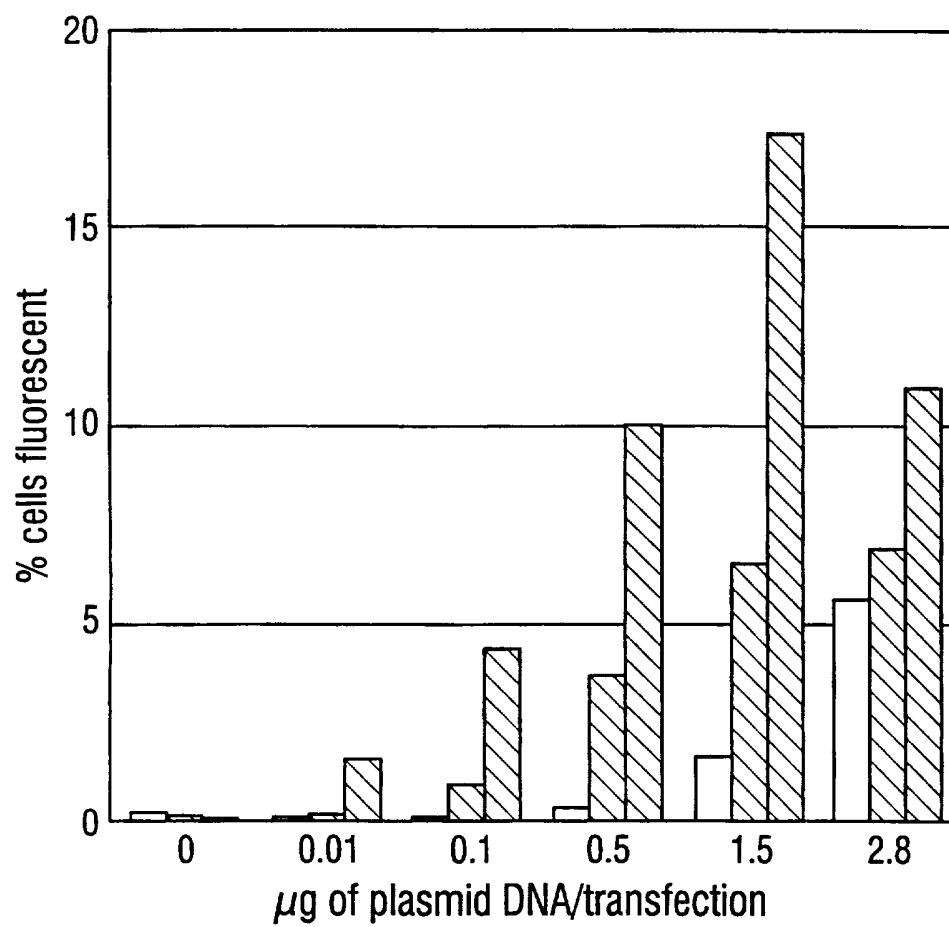

FIG. 3



FIG.4A

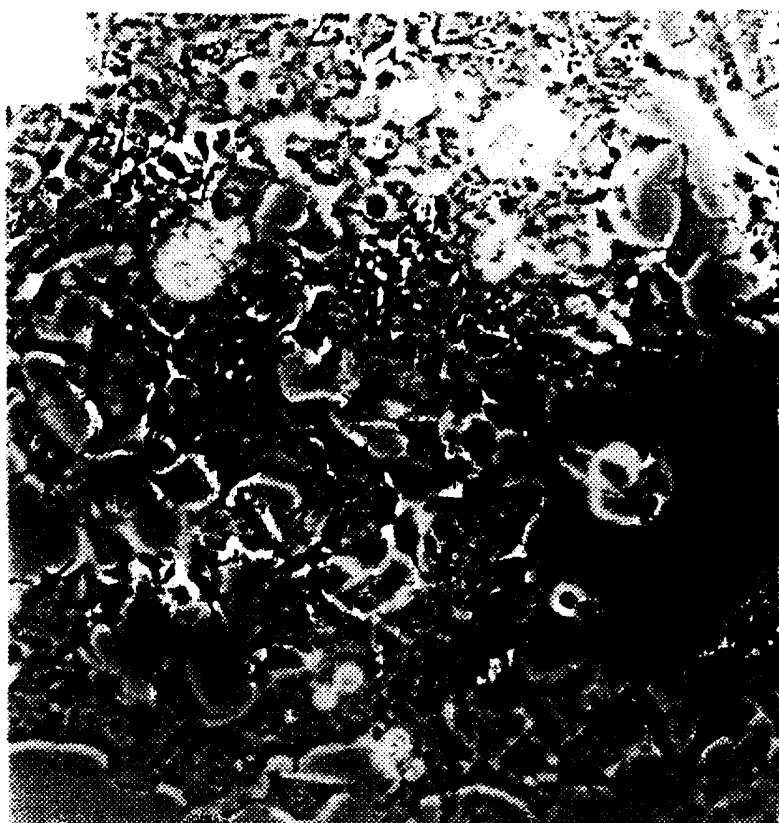

FIG.4B



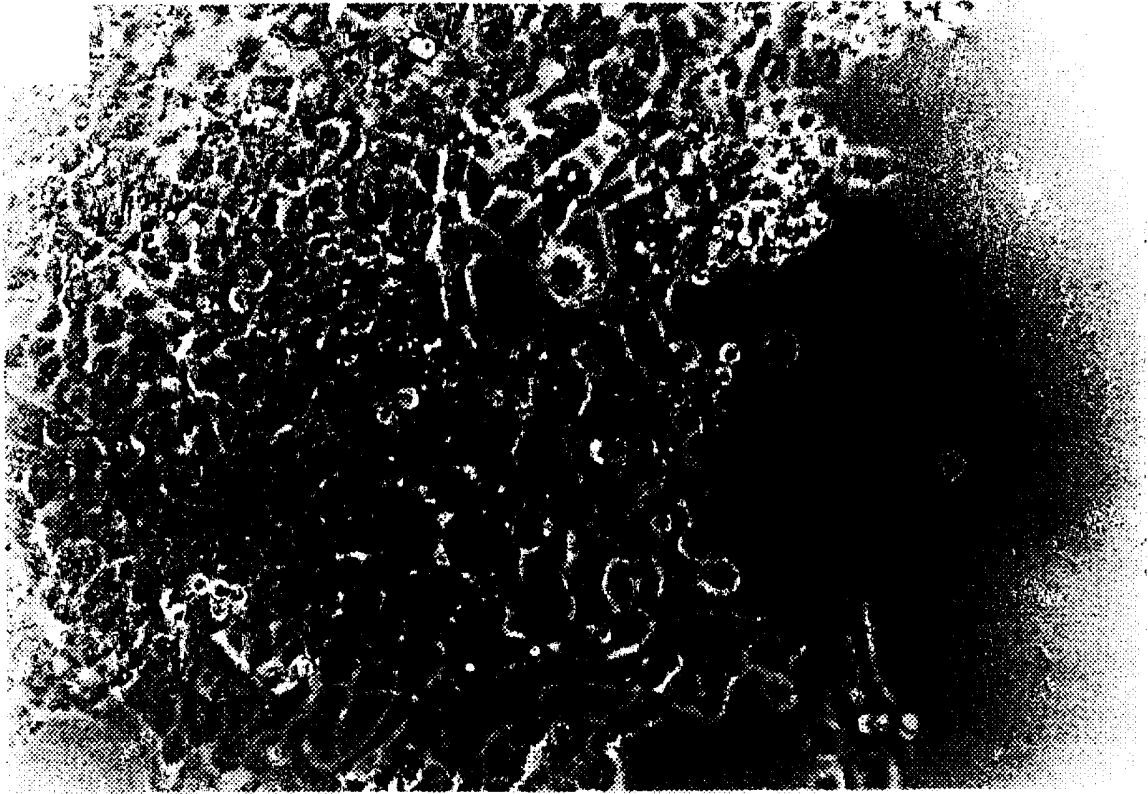

FIG. 5A



FIG. 5B



FIG.5C



FIG.5D

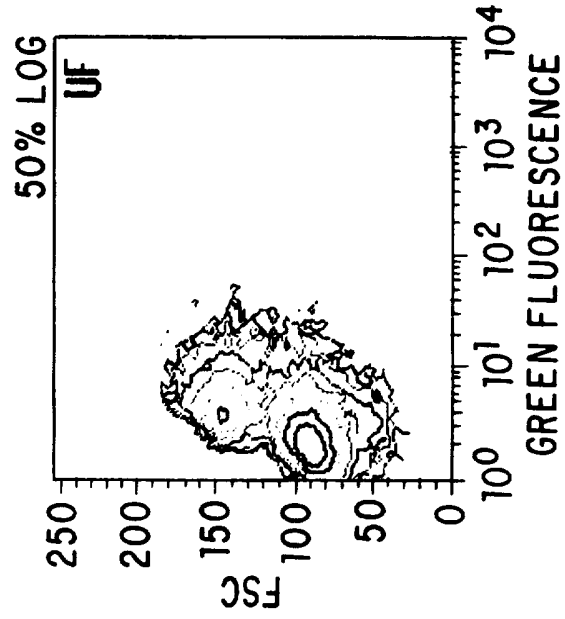

FIG. 6B

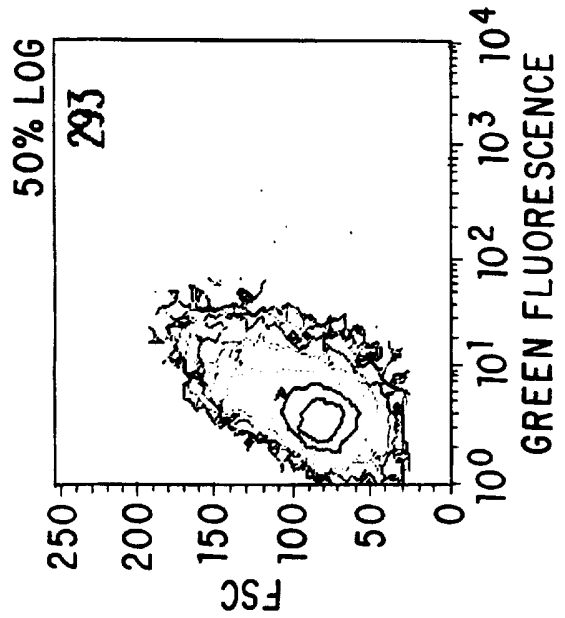

FIG. 6A

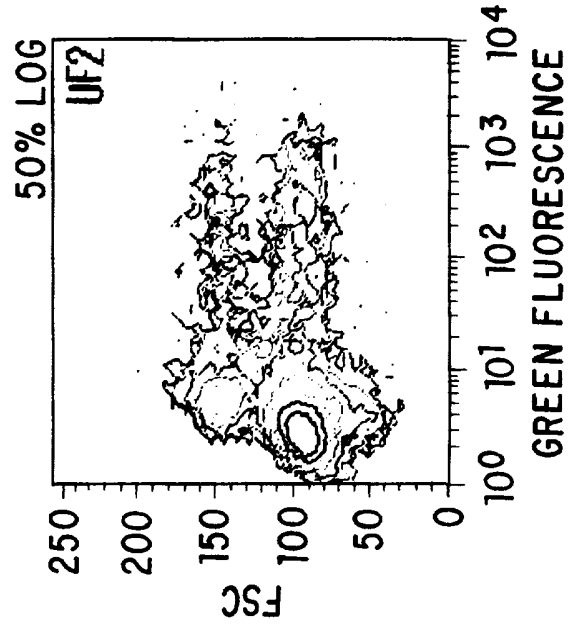

FIG. 6D

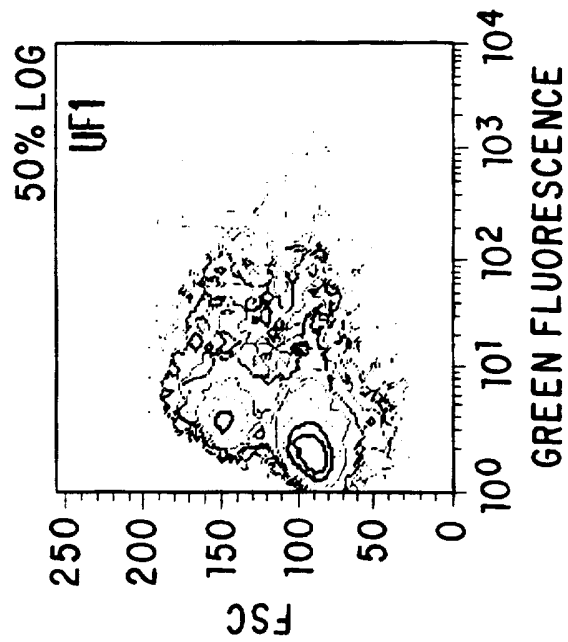

FIG. 6C



FIG. 7



FIG.8

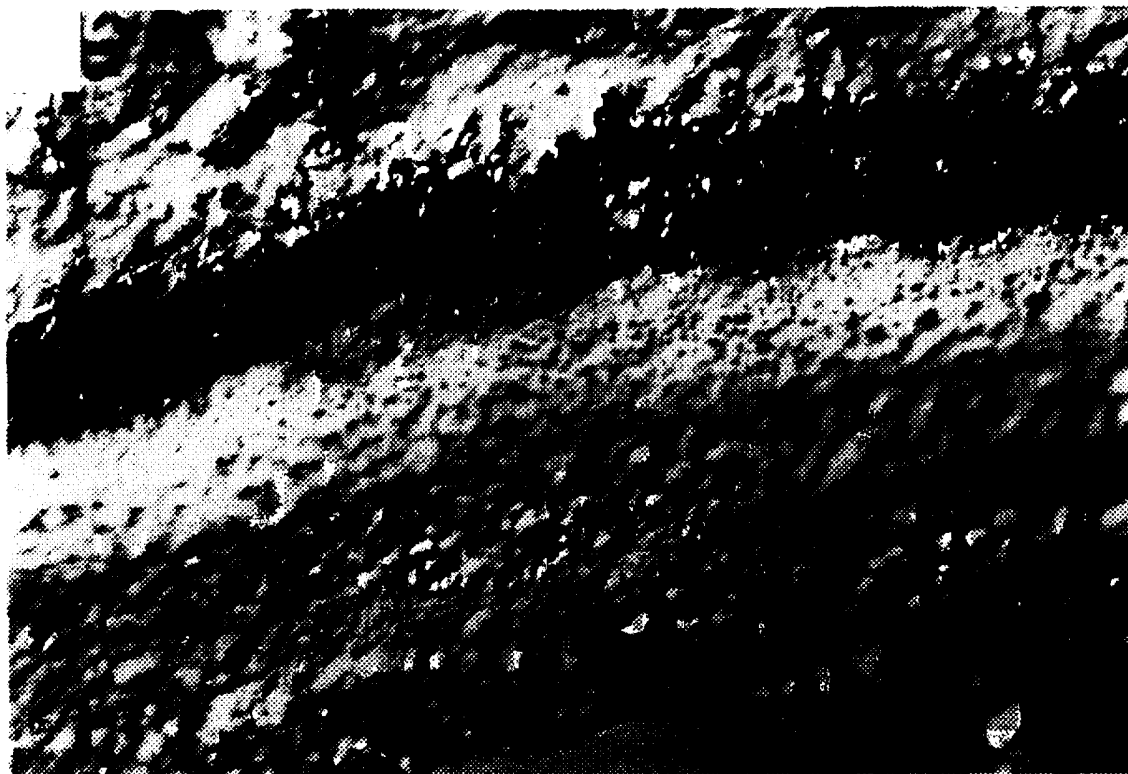

FIG.9A

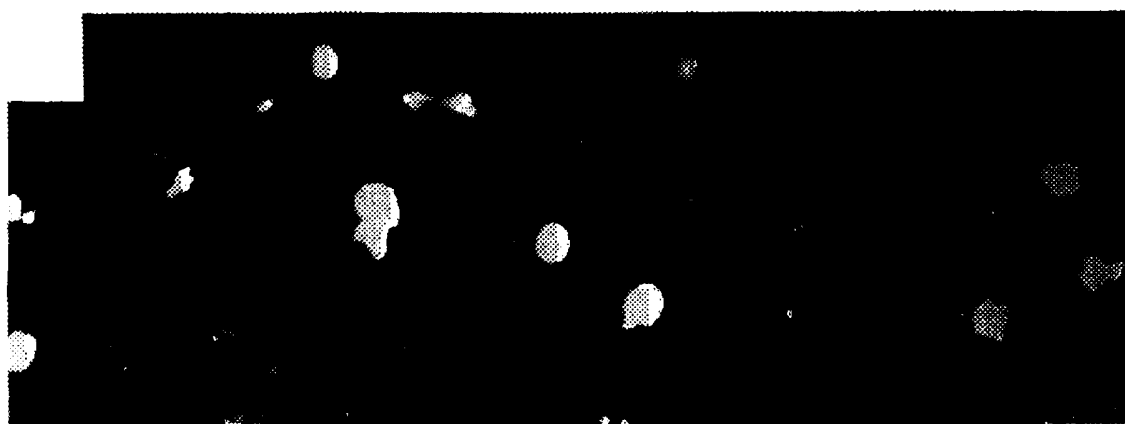

FIG.9B





FIG.9C

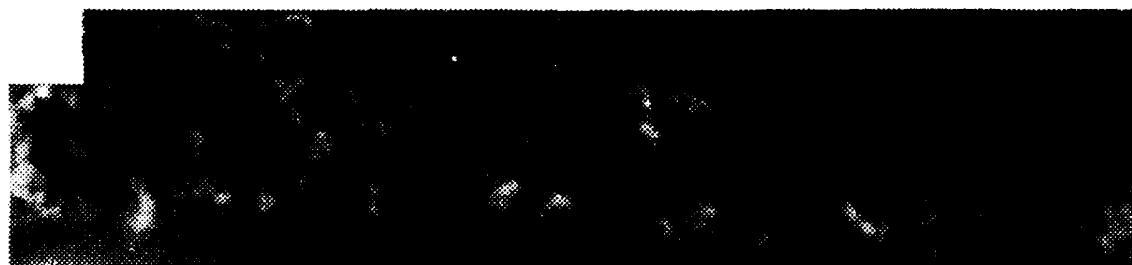

FIG.9D

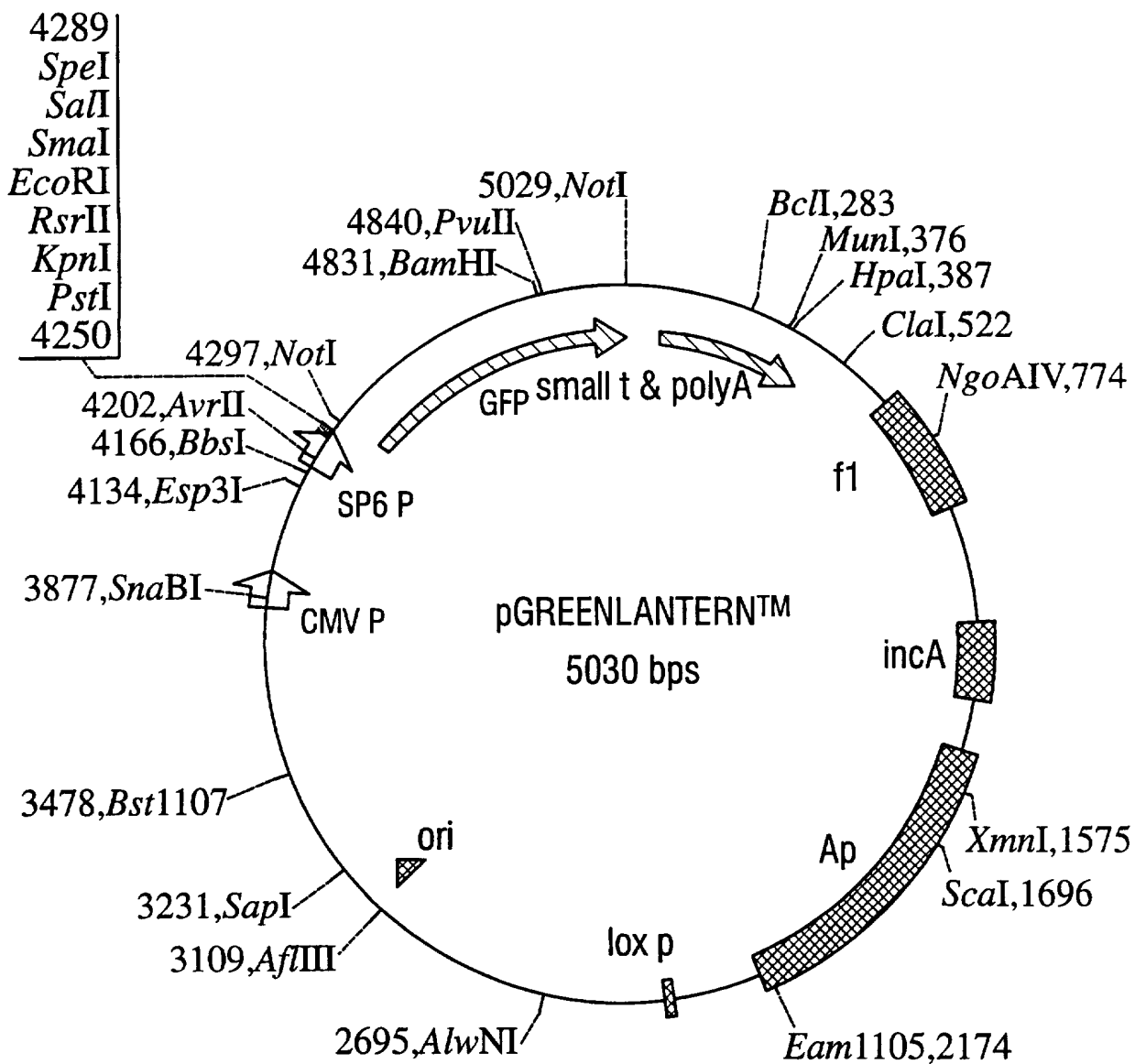

FIG. 10

# INTERNATIONAL SEARCH REPORT

International Application No  
PC1/US 97/00755

<b>A. CLASSIFICATION OF SUBJECT MATTER</b> IPC 6 C12N15/12 C12N15/62 C12N15/85 C12N15/86 C12N5/10 C07K14/435 C12Q1/02 C12Q1/68 G01N33/50 G01N33/52					
According to International Patent Classification (IPC) or to both national classification and IPC					
<b>B. FIELDS SEARCHED</b> Minimum documentation searched (classification system followed by classification symbols) IPC 6 C12N C07K C12Q G01N					
Documentation searched other than minimum documentation to the extent that such documents are included in the fields searched					
Electronic data base consulted during the international search (name of data base and, where practical, search terms used)					
<b>C. DOCUMENTS CONSIDERED TO BE RELEVANT</b>					
Category *	Citation of document, with indication, where appropriate, of the relevant passages				Relevant to claim No.
A	WO 95 07463 A (UNIV COLUMBIA ;WOODS HOLE OCEANOGRAPHIC INST (US); CHALFIE MARTIN) 16 March 1995 see the whole document ---				1-116
A	WO 95 21191 A (WARD WILLIAM ;CHALFIE MARTIN (US)) 10 August 1995 see the whole document ---				1-116
A	NATURE, vol. 373, 23 February 1995, MACMILLAN JOURNALS LTD., LONDON, UK, pages 663-664, XP002029558 R. HEIM ET AL.: "Improved green fluorescence" cited in the application see the whole document ---				1-116
-/--					
<input checked="" type="checkbox"/> Further documents are listed in the continuation of box C.			<input checked="" type="checkbox"/> Patent family members are listed in annex.		
* Special categories of cited documents : "A" document defining the general state of the art which is not considered to be of particular relevance "E" earlier document but published on or after the international filing date "L" document which may throw doubts on priority claim(s) or which is cited to establish the publication date of another citation or other special reason (as specified) "O" document referring to an oral disclosure, use, exhibition or other means "P" document published prior to the international filing date but later than the priority date claimed "T" later document published after the international filing date or priority date and not in conflict with the application but cited to understand the principle or theory underlying the invention "X" document of particular relevance; the claimed invention cannot be considered novel or cannot be considered to involve an inventive step when the document is taken alone "Y" document of particular relevance; the claimed invention cannot be considered to involve an inventive step when the document is combined with one or more other such documents, such combination being obvious to a person skilled in the art. "&" document member of the same patent family					
Date of the actual completion of the international search			Date of mailing of the international search report		
6 May 1997			09.05.97		
Name and mailing address of the ISA European Patent Office, P.B. 5818 Patentlaan 2 NL - 2280 HV Rijswijk Tel. (+ 31-70) 340-2040, Tx. 31 651 epo nl, Fax (+ 31-70) 340-3016			Authorized officer  Hornig, H		

2

## INTERNATIONAL SEARCH REPORT

International Application No

PCI/US 97/00755

## C.(Continuation) DOCUMENTS CONSIDERED TO BE RELEVANT

Category *	Citation of document, with indication, where appropriate, of the relevant passages	Relevant to claim No.
A	PROC. NATL.ACAD SCI., vol. 92, 5 December 1995, NATL. ACAD SCI., WASHINGTON, DC, US., pages 11899-11903, XP002029556 H. OGAWA ET AL.: "Localization, trafficking, and temperature-dependence of the Aequorea green fluorescent protein in cultured vertebrate cells" see the whole document ---	1-116
A	NATURE, vol. 369, 2 June 1994, MACMILLAN JOURNALS LTD., LONDON, UK, pages 400-403, XP002003600 S. WANG AND T. HAZELRIGG: "Implications for bcd mRNA localization from spatial distribution of exu protein in Drosophila oogenesis" cited in the application see the whole document ---	1-116
P,X	JOINT MEETING OF THE AMERICAN SOCIETY FOR BIOCHEMISTRY AND MOLECULAR BIOLOGY, THE AMERICAN SOCIETY FOR INVESTIGATIVE PATHOLOGY AND THE AMERICAN ASSOCIATION OF IMMUNOLOGISTS, NEW ORLEANS, LOUISIANA, USA, JUNE 2-6, 1996. FASEB JOURNAL 10 (6). 1996, 30 April 1996, page A1124 XP002030425 HAWLEY-NELSON P ET AL: "Rapid, high level detection of mammalian cell transfection with Green Lantern-1, a humanized mutant GFP reporter vector." abstract no. 727 see abstract ---	1-50, 72-77
P,X	JOINT MEETING OF THE AMERICAN SOCIETY FOR BIOCHEMISTRY AND MOLECULAR BIOLOGY, THE AMERICAN SOCIETY FOR INVESTIGATIVE PATHOLOGY AND THE AMERICAN ASSOCIATION OF IMMUNOLOGISTS, NEW ORLEANS, LOUISIANA, USA, JUNE 2-6, 1996. FASEB JOURNAL 10 (6). 1996, 30 April 1996, page A1529 XP002030426 LIFE TECHNOLOGIES INCORPORATED: "Optimized transfections using new cationic lipid reagents and a mutant " humanized " GFP transfection reporter vector." abstract no. T22 see abstract ---	1-50, 72-77

2

-/--

INTERNATIONAL SEARCH REPORT

International Application No  
PCT/US 97/00755

C.(Continuation) DOCUMENTS CONSIDERED TO BE RELEVANT		
Category *	Citation of document, with indication, where appropriate, of the relevant passages	Relevant to claim No.
P,X	<p>NATURE BIOTECHNOLOGY 14 (5). 1996. 610-615. ISSN: 1087-0156, May 1996, XP000673366 LEVY J P ET AL: "Retroviral transfer and expression of a humanized, red-shifted green fluorescent protein gene into human tumor cells." see the whole document ---</p>	<p>1-50, 72-77, 81, 83-86, 88,95, 109</p>
P,X	<p>JOURNAL OF VIROLOGY 70 (7). 1996. 4646-4654. ISSN: 0022-538X, July 1996, XP002030427 ZOLOTUKHIN S ET AL: "A "humanized" green fluorescent protein cDNA adapted for high-level expression in mammalian cells." see the whole document ---</p>	<p>1-109</p>
P,X	<p>BIOCHEM. BIOPHYS. RES. COMMUN. (1996), 225(2), 420-426 CODEN: BBRC9;ISSN: 0006-291X, 14 August 1996, XP002030428 WANG, DENG-SHUN ET AL: "The Pleckstrin Homology domain of human.beta.I.SIGMA.II spectrin is targeted to the plasma membrane in vivo" see the whole document -----</p>	<p>1-50, 72-77, 81, 84-86, 88-91, 101</p>

INTERNATIONAL SEARCH REPORT

International application No.

PCT/US 97/ 00755

**Box I Observations where certain claims were found unsearchable (Continuation of item 1 of first sheet)**

This International Search Report has not been established in respect of certain claims under Article 17(2)(a) for the following reasons:

1.  Claims Nos.: 84-112  
because they relate to subject matter not required to be searched by this Authority, namely:  
Remark: As far as claims 84-112 are directed to a method of treatment of (diagnostic method practised on) the human/animal body, the search has been carried out and based on the alleged effects of the compound/ composition.
2.  Claims Nos.:  
because they relate to parts of the International Application that do not comply with the prescribed requirements to such an extent that no meaningful International Search can be carried out, specifically:
3.  Claims Nos.:  
because they are dependent claims and are not drafted in accordance with the second and third sentences of Rule 6.4(a).

**Box II Observations where unity of invention is lacking (Continuation of item 2 of first sheet)**

This International Searching Authority found multiple inventions in this international application, as follows:

1.  As all required additional search fees were timely paid by the applicant, this International Search Report covers all searchable claims.
2.  As all searchable claims could be searched without effort justifying an additional fee, this Authority did not invite payment of any additional fee.
3.  As only some of the required additional search fees were timely paid by the applicant, this International Search Report covers only those claims for which fees were paid, specifically claims Nos.:
4.  No required additional search fees were timely paid by the applicant. Consequently, this International Search Report is restricted to the invention first mentioned in the claims; it is covered by claims Nos.:

Remark on Protest

- The additional search fees were accompanied by the applicant's protest.
- No protest accompanied the payment of additional search fees.

# INTERNATIONAL SEARCH REPORT

Information on patent family members

International Application No

PCT/US 97/00755

Patent document cited in search report	Publication date	Patent family member(s)	Publication date
WO 9507463 A	16-03-95	US 5491084 A AU 7795794 A CA 2169298 A EP 0759170 A	13-02-96 27-03-95 16-03-95 26-02-97
-----	-----	-----	-----
WO 9521191 A	10-08-95	NONE	
-----	-----	-----	-----