



- (51) International Patent Classification:  
F16B 19/05 (2006.01) F16B 43/00 (2006.01)  
F16B 33/00 (2006.01)
- (21) International Application Number:  
PCT/US2012/030099
- (22) International Filing Date:  
22 March 2012 (22.03.2012)
- (25) Filing Language: English
- (26) Publication Language: English
- (30) Priority Data:  
61/467,002 24 March 2011 (24.03.2011) US
- (71) Applicant (for all designated States except US): **ALCOA INC.** [US/US]; 201 Isabella Street, Pittsburgh, PA 15212-5858 (US).
- (72) Inventors; and
- (75) Inventors/Applicants (for US only): **HAYLOCK, Luke** [US/US]; 11007 Ocean Drive, Culver City, CA 90230 (US). **MALAZIMOGLU, Hasim** [US/US]; 8203 Manno Circle, Buena Park, CA 90621 (US). **PINHEIRO, Rodrigo** [US/US]; 11232 Streamfield Court, Riverside, CA 92505 (US).

(74) Agent: **AGOSTINO, Joseph**; C/o Greenberg Traurig, LLP, Alcoa Inc., 100 Technical Drive, Alcoa Center, PA 15069 (US).

(81) Designated States (unless otherwise indicated, for every kind of national protection available): AE, AG, AL, AM, AO, AT, AU, AZ, BA, BB, BG, BH, BR, BW, BY, BZ, CA, CH, CL, CN, CO, CR, CU, CZ, DE, DK, DM, DO, DZ, EC, EE, EG, ES, FI, GB, GD, GE, GH, GM, GT, HN, HR, HU, ID, IL, IN, IS, JP, KE, KG, KM, KN, KP, KR, KZ, LA, LC, LK, LR, LS, LT, LU, LY, MA, MD, ME, MG, MK, MN, MW, MX, MY, MZ, NA, NG, NI, NO, NZ, OM, PE, PG, PH, PL, PT, QA, RO, RS, RU, RW, SC, SD, SE, SG, SK, SL, SM, ST, SV, SY, TH, TJ, TM, TN, TR, TT, TZ, UA, UG, US, UZ, VC, VN, ZA, ZM, ZW.

(84) Designated States (unless otherwise indicated, for every kind of regional protection available): ARIPO (BW, GH, GM, KE, LR, LS, MW, MZ, NA, RW, SD, SL, SZ, TZ, UG, ZM, ZW), Eurasian (AM, AZ, BY, KG, KZ, MD, RU, TJ, TM), European (AL, AT, BE, BG, CH, CY, CZ, DE, DK, EE, ES, FI, FR, GB, GR, HR, HU, IE, IS, IT, LT, LU, LV, MC, MK, MT, NL, NO, PL, PT, RO, RS, SE, SI, SK, SM, TR), OAPI (BF, BJ, CF, CG, CI, CM, GA, GN, GQ, GW, ML, MR, NE, SN, TD, TG).

Published:  
— with international search report (Art. 21(3))

(54) Title: HYBRID COLLAR FOR FASTENING SYSTEMS

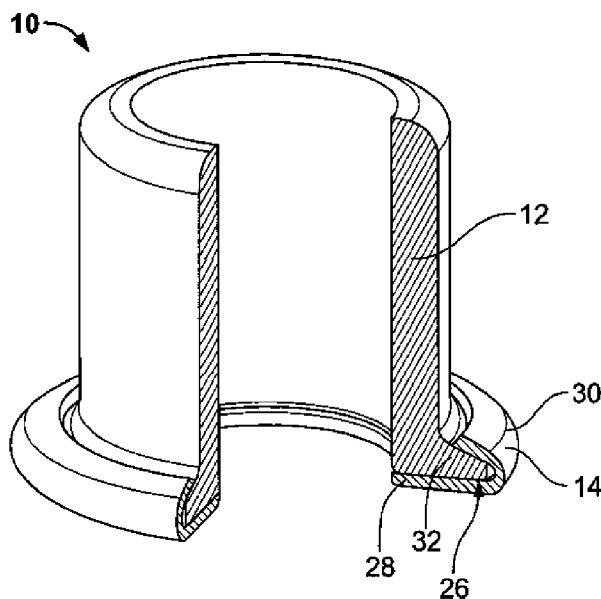

FIG. 2A

(57) Abstract: A collar (10) includes a collar body (12) having a flange (32) and a bearing surface (26), and a base element (14) attached to the collar body (12). The base element (14) includes a base portion (28) that covers the bearing surface (26) of the collar body (12), and a securing portion (30) that is joined to the flange (32) of the collar body (12). The base element (14) can be a flat base element (28), a ridge base element (34), or a swivel base element (42). The securing portion (30) can be crimped onto the flange (32) of the collar body (12). The collar body (12) is made from a first material and the base element (14) is made from a second material that is galvanically compatible with the first material. The first material may be aluminum or an aluminum alloy, while the second material may be steel, a steel alloy, titanium, or a titanium alloy. The collar (10) is adapted to be installed on a structure made of a composite material.

WO 2012/129390 A1

## HYBRID COLLAR FOR FASTENING SYSTEMS

### Cross-Reference to Related Application

This application is a Section 111(a) application relating to and claims  
5 the benefit of commonly owned, co-pending U.S. Provisional Application  
Serial No. 61/467,002 entitled "HYBRID COLLAR FOR FASTENING  
SYSTEMS", filed March 24, 2011, the entirety of which is incorporated  
herein by reference.

### 10 Technical Field of the Invention

The present invention relates to a collar for a fastening system and,  
more particularly, a hybrid collar for protection from galvanic corrosion  
between the collar and a structure.

### 15 Background Art

The use of composite materials, such as carbon fiber reinforced  
plastics (CFRP), is becoming more common in the aerospace industry as  
advancements on composite technologies increase. A significant portion of  
a composite structure is fabricated as near net-shape, but it is drilled in  
20 order to facilitate the joining of components by using mechanical fasteners.  
One of the most essential criteria for choosing fasteners for aircraft  
structures is the galvanic corrosion compatibility between the fasteners and  
the joined components.

**Disclosure of the Invention**

In an embodiment, a collar for a fastening system includes a collar body having a first end, a second end opposite the first end, and a flange located at the second end and having a bearing surface; and a base element attached to the collar body, the base element including a base portion that covers the bearing surface of the collar body, and a securing portion that is joined to the flange of the collar body. In an embodiment, the collar body is made from a first material and the base element is made from a second material that is galvanically compatible with the first material. In an embodiment, the first material is selected from the group consisting of aluminum and aluminum alloys. In an embodiment, the second material is selected from the group consisting of steel, steel alloys, titanium, and titanium alloys.

In an embodiment, the securing portion of the base element is crimped on the flange of the collar body. In an embodiment, the collar body includes an aperture extending from the first end to the second thereof and forming an inner wall, and wherein the base element includes a sealing portion that extends into the aperture of the collar body and covers a portion of the inner wall. In an embodiment, the base element includes a swivel base element that is adapted to rotate relative to the collar body. In an embodiment, the collar is adapted to be installed on a structure made of a composite material.

In an embodiment, the collar has a coating that includes an organic material and a non-conductive filler. In an embodiment, the organic material is a polymer material, and the non-conductive filler is selected from the group consisting of aluminum pigmented paint, chromated paint, and sol-gel coatings. In an embodiment, the coating is applied to every portion of the collar body. In an embodiment, the coating is be applied on the collar body selectively.

In an embodiment, the collar is a threaded collar. In another embodiment, the collar is a swage collar.

In an embodiment, a collar body having a first end and a second end opposite the first end, the collar body being made from a first material; and a flange located at the second end of the collar body, the flange being made from a second material that is galvanically compatible with the first material. In an embodiment, the collar body and the flange are formed integrally with one another. In an embodiment, the first material is selected from the group consisting of aluminum and aluminum alloys. In an embodiment, the second material is selected from the group consisting of steel, steel alloys, titanium, and titanium alloys.

## **Brief Description of the Drawings**

For a more complete understanding of the present invention, reference is made to the following detailed description of exemplary embodiments considered in conjunction with the accompanying drawings, in which:

**FIG. 1** is a cross-sectional view of an embodiment of a lockbolt fastener system;

**FIG. 2A** is a partially sectioned perspective view of an embodiment of a hybrid collar adapted for use in the fastener system shown in **FIG. 1**,  
5 the collar including a flat base element;

**FIG. 2B** is a partially sectioned perspective view of another embodiment of a hybrid collar including a ridge base element;

**FIG. 2C** is a partially sectioned perspective view of another embodiment of a hybrid collar including a swivel base element;

10 **FIG. 2D** is a partially sectioned perspective view of another embodiment of a hybrid collar including an integrally formed flange;

**FIG. 3** is a graph showing a comparison of specific tensile strength (UTS/density) of various collar materials;

**FIG. 4** is a perspective view of an embodiment of a plurality of hybrid  
15 collars installed on a carbon fiber reinforced plastic (CFRP) structure;

**FIG. 5** is a micrograph showing a functional gradient microstructure of hybrid collar achieved by in-situ cold working during fastener installation;

**FIG. 6** is a graph illustrating the tensile strength of an aluminum hybrid collar versus a titanium collar showing equivalent ultimate strength;  
20 and

**FIG. 7** are perspective views of an embodiment of hybrid collars tested with composite plate after salt spray corrosion testing.

**Best Mode for Carrying Out the Invention**

In an embodiment, a hybrid collar **10** is adapted to prevent galvanic corrosion and reduce weight as compared to a conventional titanium lockbolt collar. In an embodiment, the collar **10** combines a collar body **12** with a galvanically compatible base element **14**. In an embodiment, the collar **10** is a lockbolt collar with a controlled swaging feature and used in a fastener assembly **16** having a threaded pin **18** as illustrated in **FIG. 1**, for fastening a plurality of workpieces **20, 22**. In an embodiment, the fastener assembly **16** includes a sleeve **24** inserted into aligned holes of the workpieces **20, 22**, and is sized and shaped to receive the pin **18**. In an embodiment, the collar **10** is used in connection with aerospace applications, such as aircraft. In other embodiments, the collar **10** can be used in other applications and fields.

Referring to **FIGS. 2A** through **2C**, the collar **10** includes the collar body **12**, which is relatively soft and deformable, and a galvanically compatible base element **14**. In an embodiment, the base element **14** is a washer which is suitable for composite structures, as shown in **FIGS. 2A** through **2C**. In another embodiment, the collar **10** includes only the soft, deformable collar body **12**, as shown in **FIG. 2D**, which is suitable for metallic structures.

In a number of embodiments, materials for the soft, deformable collar body **12** may include, but are not limited to, aluminum and its alloys, such as 2099, 7075, 2024 and 6061. **FIG. 3** is a graph showing a comparison of specific tensile strength (UTS/density) of various collar

materials. In particular, in an embodiment, the graph shows that the specific tensile strength of aluminum 2099 compares favorably with other materials used to make collars.

**FIG. 4** illustrates an embodiment of a plurality of the collars **10** installed on a carbon fiber reinforced plastic (CFRP) workpiece.

In an embodiment, the collar **10** may have a nano-grain structure achieved by cold working the collar **10** via in-situ forming process during fastener installation and creating a functional gradient material (FGM), as shown in **FIG. 5**. In an embodiment, this gradient in microstructure results in gradient in properties across the collar's **10** cross section and provides the necessary functional properties, namely, high tensile and shear strength approximately equal to those of titanium collars and higher corrosion resistance. In an embodiment, the degree of the cold working of the collar **10** is also controlled by varying an outside diameter of the collar **10** to provide a specified amount of deformed structure. In an embodiment, the specified collar outside diameter dimension for the collar's **10** size maintains the critical deformation needed for improved performance, but keeps it below levels that may lead to unintended cracking of the collar **10** during installation. In other embodiments, the FGM in other types of fasteners such as frangible collars, can be created by other means of cold working, such thread tapping or thread rolling operations.

In other embodiments, the collar **10** includes a coating comprising a combination of organic materials and non-conductive fillers. In an embodiment, the organic material of the coating can include the family of

polymers, such as epoxies, and the non-conductive fillers can include aluminum pigmented or chromated paints and the family of sol-gel coatings. In one embodiment, the coating can be applied to every portion of the collar **10**, specifically to the collar body **12**. In other embodiments, the coating can be applied on the collar body **12** selectively, depending on desired joint performance. In another embodiment, the outer surface of the collar body **12** can include a coating comprised of a first material, and the inner surface of the collar body **12** can include a coating comprised of second material different from the first material.

10 In an embodiment, the collar **10** is electrically isolated from more noble structures, such as composite, by use of the close fitting base element **14**, such as a captive washer inserted under and covering a bearing surface **26** of the collar body **12**. In an embodiment, the base element **14** can be selected from a group of metallic materials which are  
15 known to be galvanically compatible to a composite structure. In an embodiment, these materials include steel, titanium, and their alloys. In other embodiments, other alloys and non-metallic materials may be used.

In an embodiment, the base element **14** not only provides protection from galvanic corrosion between the collar **10** and the CFRP structure, but  
20 plays an important role as one of the critical structural elements of the fastener system **16**. In an embodiment, as shown in FIG. 2A, the base element **14** includes a flat base **28** that covers the bearing surface **26** of the collar body **12** and a securing portion **30** that is crimped and secured to a flange **32** of the collar body **12**. In an embodiment, the securing portion **30**

is angled obliquely relative to the base **28**. In another embodiment, as shown in **FIG. 2B**, the base element **14** includes a ridge base **34** similar in structure to the base element **14** shown in **FIG. 2A**, but includes a sealing portion **36** that extends into the aperture **38** of the collar body **12** and partially covers an inner wall **40** thereof. In an embodiment, the sealing portion **36** acts as a seal for preventing moisture and other external elements from infiltrating the aperture **38** of the collar body **12**. In another embodiment, as shown in **FIG. 2C**, the base element **14** includes a swivel base element **42**, whereby a gap **44** or clearance is formed between the flange **32** of the collar body **12** and the securing portion **30**, thereby allowing the swivel base element **42** to rotate relative to the collar body **12**, and vice-versa. In an embodiment, the aforescribed base elements **14** are rigid, and, therefore, they can accommodate any possible hole misalignment during fastener installation, thereby creating a self-aligning fastener. In an embodiment, in instances where the hole(s) of the workpieces **20**, **22** is oversized or misaligned, the base element **14** fills any gaps between the holes and the pin **18** and assists in aligning the pin **18**.

In an embodiment, the base element **14** mitigates composite bearing deformation when the collar **10** is used in a composite structure. In an embodiment, the base element **14** enables the collar body **12** to form during installation without direct contact with the structure. As a result, this prevents deformation (i.e., surface friction) of the collar **10** from translating into the structure.

In an embodiment, the collar **10** is galvanically compatible for both metallic and composite structure applications, is lighter in weight, and is less expensive as compared to titanium fasteners, and have comparable strength to titanium fasteners, as shown in the graph of **FIG. 6**. In an  
5 embodiment, the collar **10** is about 30% to 50% lighter than comparable titanium collars, due to the lower density of the materials used for the collar body **12**. In another embodiment, the collar **10** is about 40% lighter than comparable titanium collars.

**FIG. 7** illustrates an embodiment of a plurality of the collars **10**  
10 tested with a composite plate after salt spray corrosion testing. In an embodiment, the collars **10** show no evidence of any galvanic corrosion after a 250 hour salt spray exposure.

It will be understood that the embodiments described herein are merely exemplary and that a person skilled in the art may make many  
15 variations and modifications without departing from the spirit and scope of the invention. For instance, in an embodiment, the collar **10** can be a threaded member. In an embodiment, the collar **10** may be a lightly threaded collar having internal threads for aligning it on the threaded portion of the pin **18** and, thereafter, the collar **10** can be swaged onto the  
20 pin **18**. In other embodiments, the collar **18** may include a single thread for the aforesaid alignment purposes, as disclosed in U.S. Patent No. 4,867,625 to Dixon, which is incorporated by reference herein.

In another embodiment, the collar body **12** of the collar **10** may be a two-piece element, such that the elongated, tubular member of the collar

body 12 is made from a soft, deformable material, such as aluminum and its alloys as described above, and the flange is made from a galvanically compatible material, such as titanium, steel, and their alloys as described above, and in which the tubular member and the flange are attached to one another. In on or more embodiments, the tubular member and the flange are attached to one another by friction welding, adhesives, or other suitable attachment means known in the art.

It should be understood that the embodiments described herein are merely exemplary and that a person skilled in the art may make many variations and modifications without departing from the spirit and scope of the invention. All such variations and modifications are intended to be included within the scope of the invention as defined in the appended claims.

**CLAIMS**

What is claimed is:

1. A collar, comprising:  
a collar body having a first end, a second end opposite the first end,  
5 and a flange located at the second end and having a bearing surface; and  
a base element attached to the collar body, the base element  
including a base portion that covers the bearing surface of the collar body,  
and a securing portion that is joined to the flange of the collar body.
- 10 2. The collar of Claim 1, wherein the collar body is made from a first  
material and the base element is made from a second material that is  
galvanically compatible with the first material.
3. The collar of Claim 2, wherein the first material is selected from the  
15 group consisting of aluminum and aluminum alloys.
4. The collar of Claim 3, wherein the second material is selected from  
the group consisting of steel, steel alloys, titanium, and titanium alloys.
- 20 5. The collar of Claim 2, wherein the securing portion of the base  
element is crimped on the flange of the collar body.
6. The collar of Claim 2, wherein the collar body includes an aperture  
extending from the first end to the second thereof and forming an inner wall,

and wherein the base element includes a sealing portion that extends into the aperture of the collar body and covers a portion of the inner wall.

7. The collar of Claim 2, wherein the base element includes a swivel  
5 base element that is adapted to rotate relative to the collar body.
8. The collar of Claim 2, wherein the collar is adapted to be installed on a structure made of a composite material.
- 10 9. The collar of Claim 2, further comprising a coating that includes an organic material and a non-conductive filler.
10. The collar of Claim 7, wherein the organic material is a polymer material, and the non-conductive filler is selected from the group consisting  
15 of aluminum pigmented paint, chromated paint, and sol-gel coatings.
11. The collar of Claim 9, wherein the coating is applied to every portion of the collar body.
- 20 12. The collar of Claim 9, wherein the coating is be applied on the collar body selectively.
13. The collar of Claim 2, wherein the collar is a threaded collar.

14. The collar of Claim 2, wherein the collar is a swage collar.
15. A collar, comprising:  
a collar body having a first end and a second end opposite the first  
5 end, the collar body being made from a first material; and  
and a flange located at the second end of the collar body, the flange  
being made from a second material that is galvanically compatible with the  
first material.
- 10 16. The collar of Claim 15, wherein the collar body and the flange are  
formed integrally with one another.
17. The collar of Claim 16, wherein the first material is selected from the  
group consisting of aluminum and aluminum alloys.
- 15 18. The collar of Claim 17, wherein the second material is selected from  
the group consisting of steel, steel alloys, titanium, and titanium alloys.

1/7

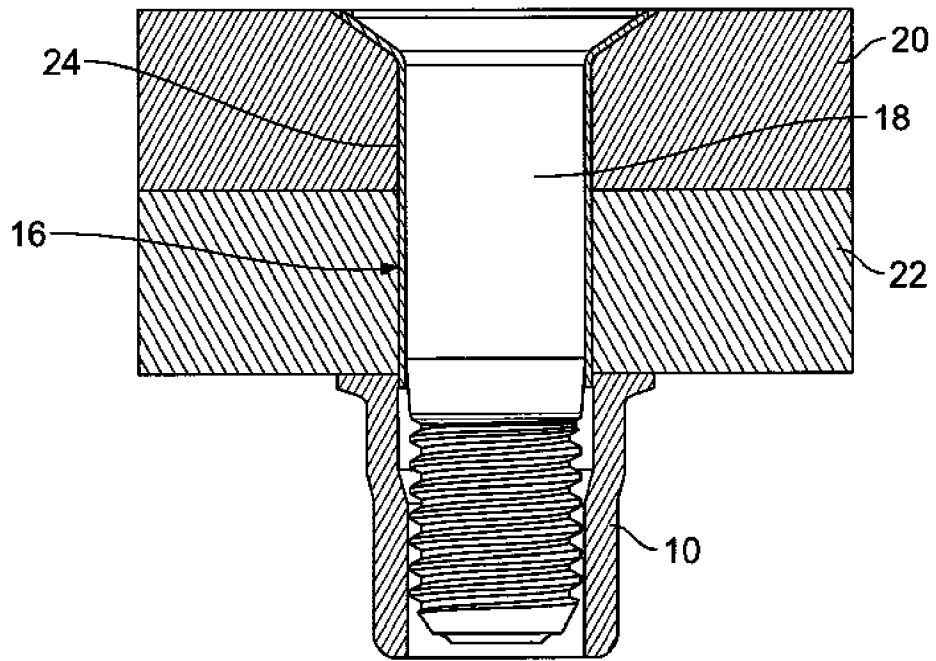

FIG. 1

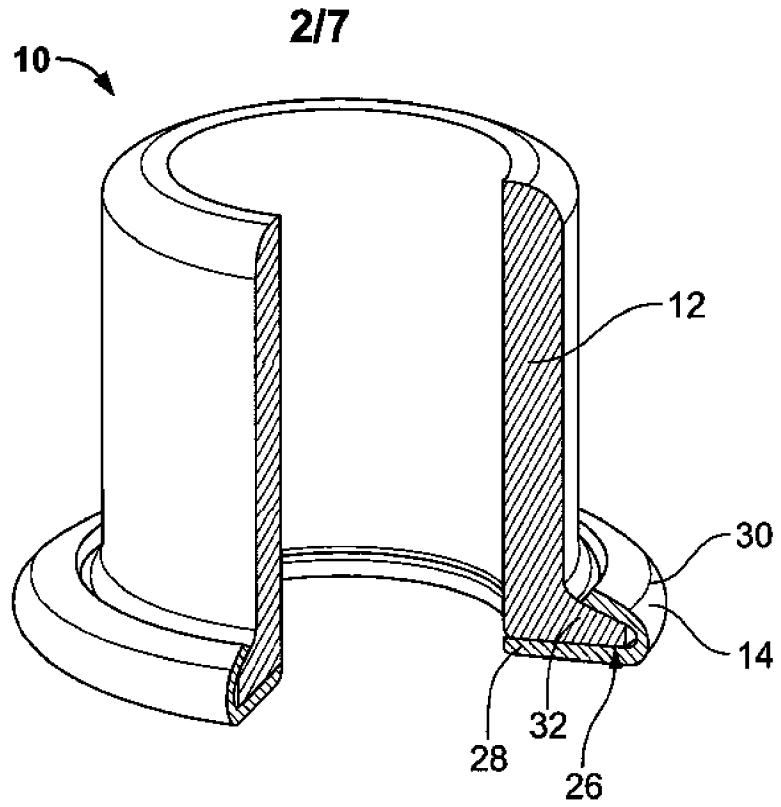

FIG. 2A

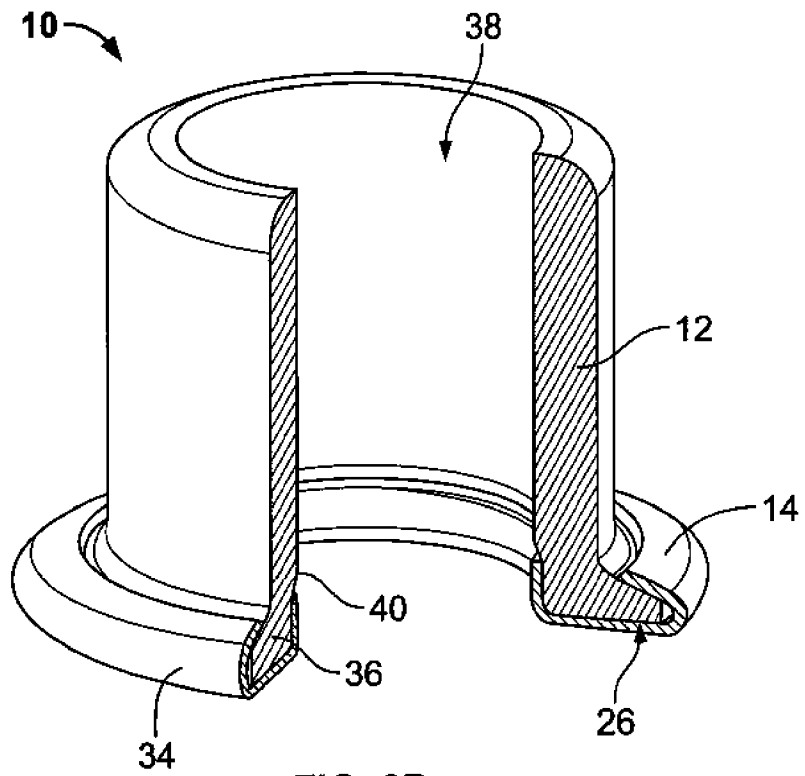

FIG. 2B

3/7

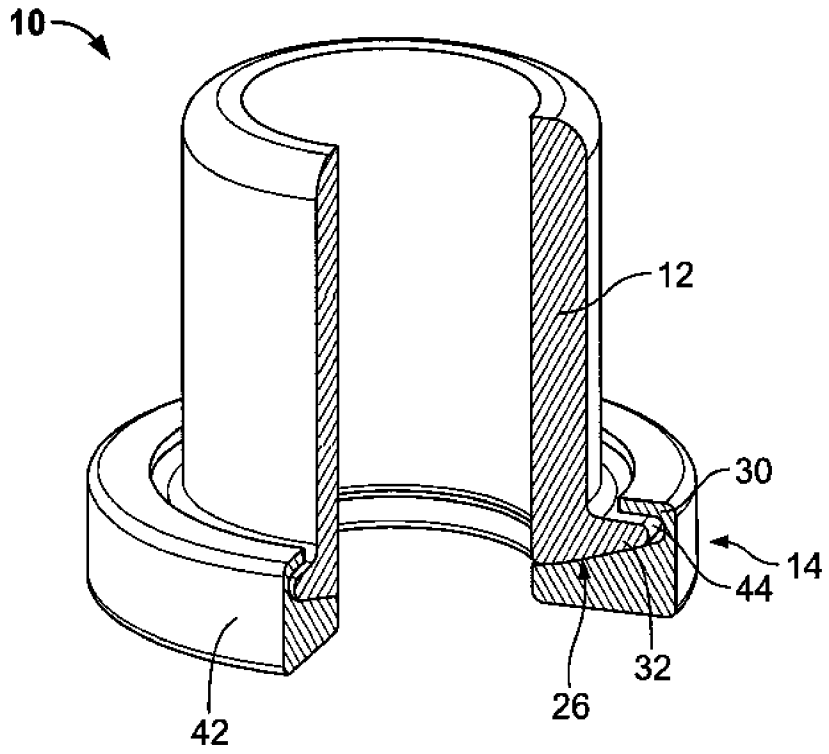

FIG. 2C

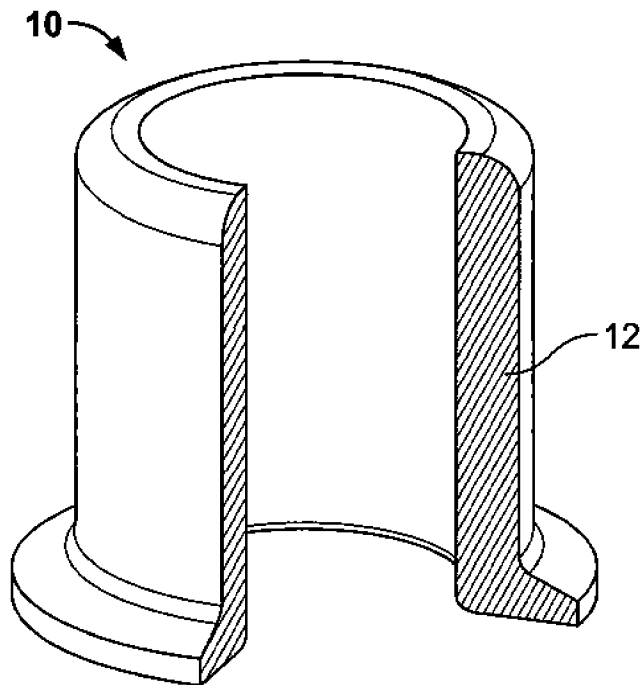
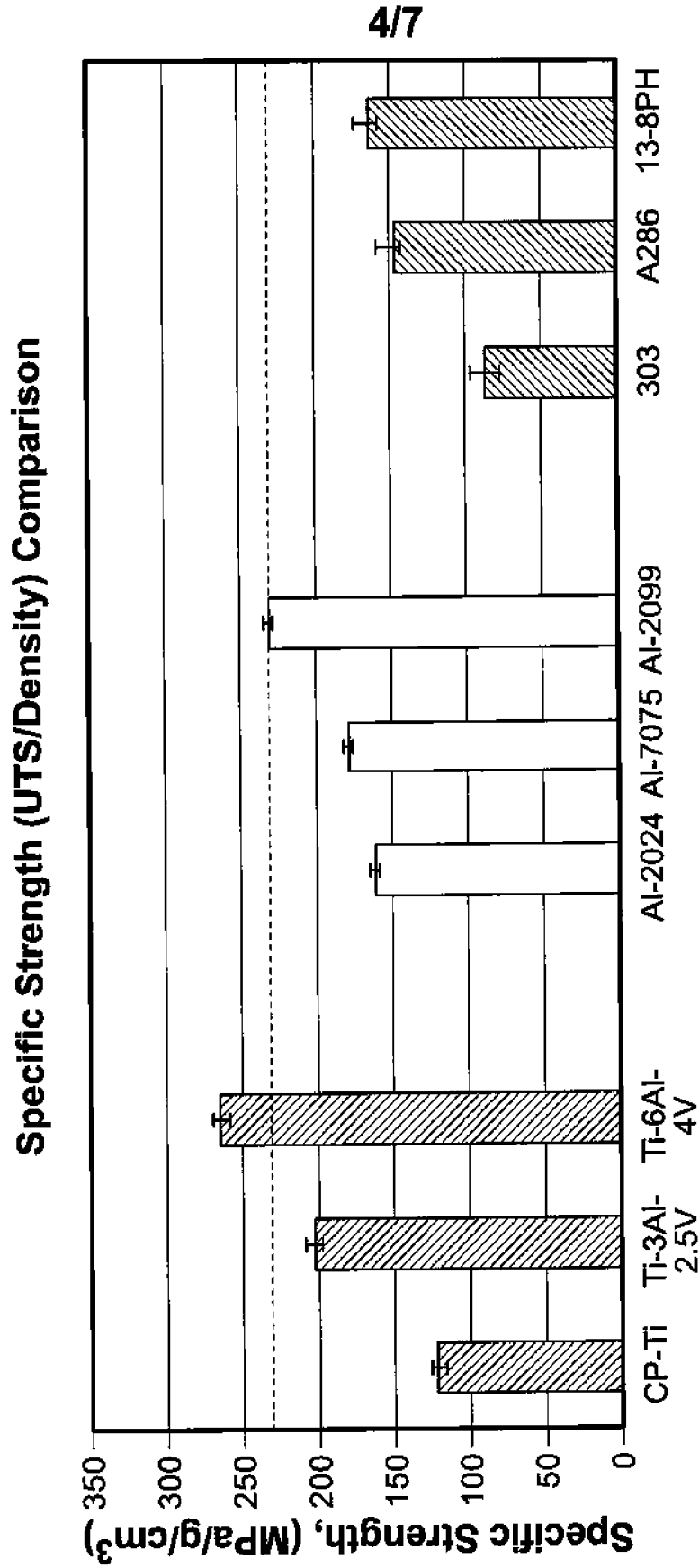

FIG. 2D



**FIG. 3**

5/7

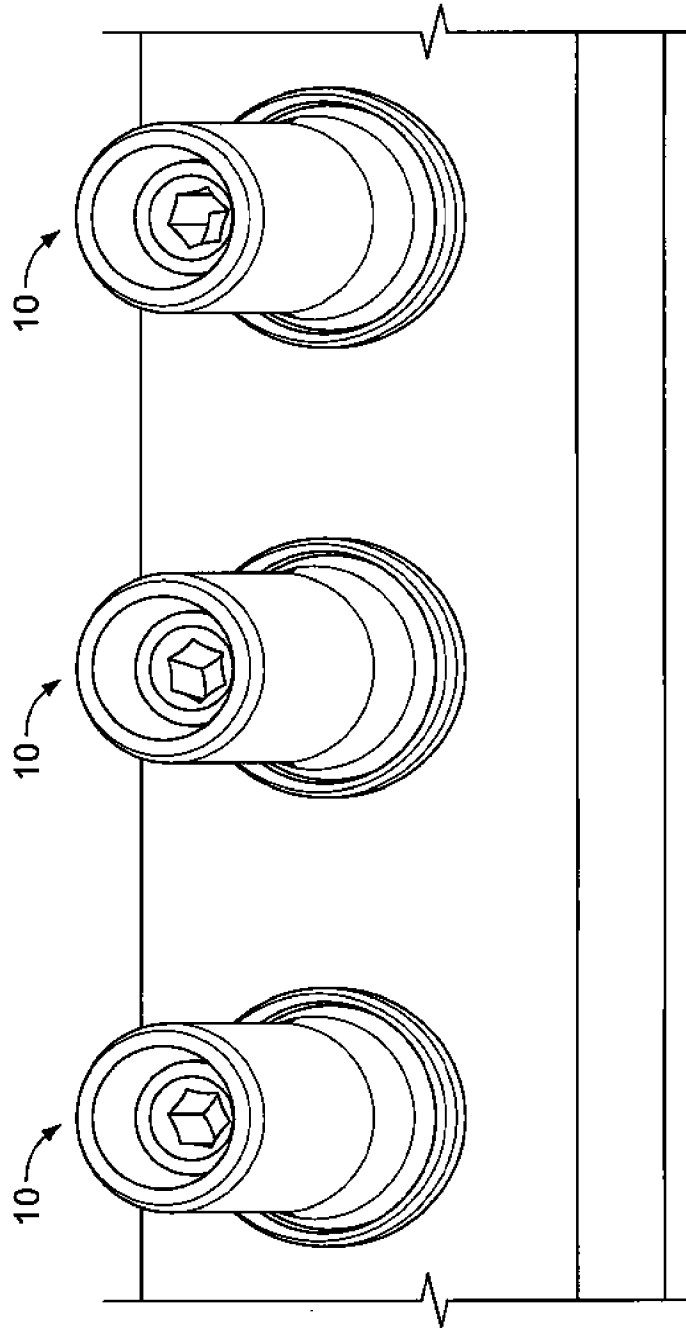

FIG. 4

6/7

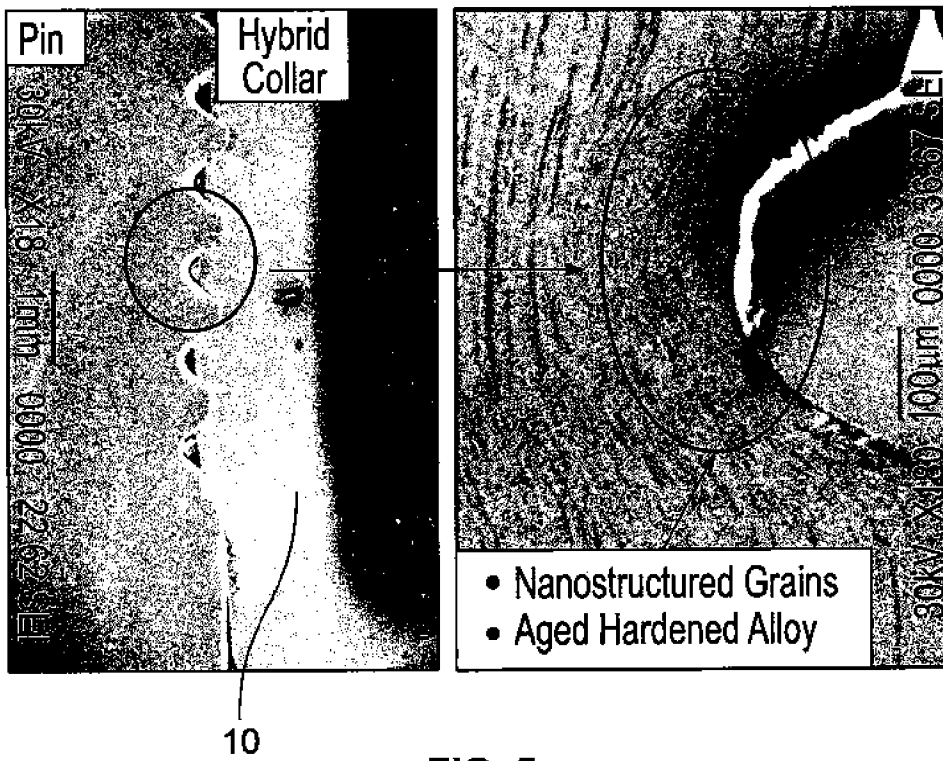

FIG. 5

7/7

Ultimate Strength

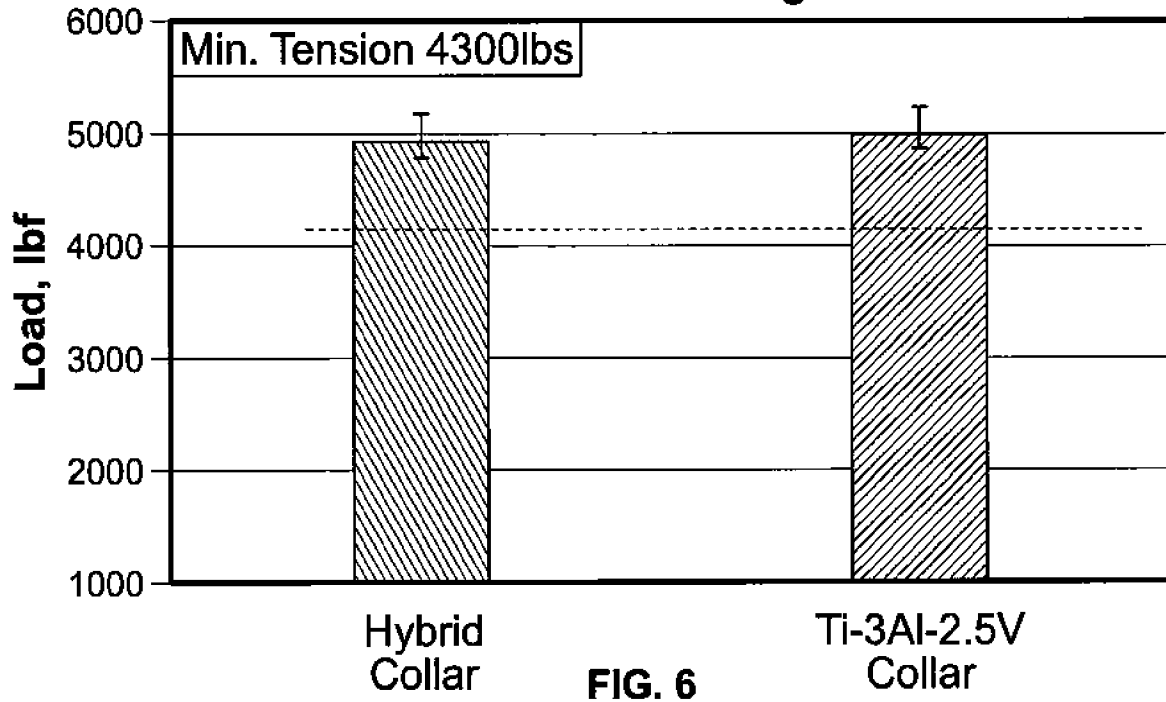

FIG. 6

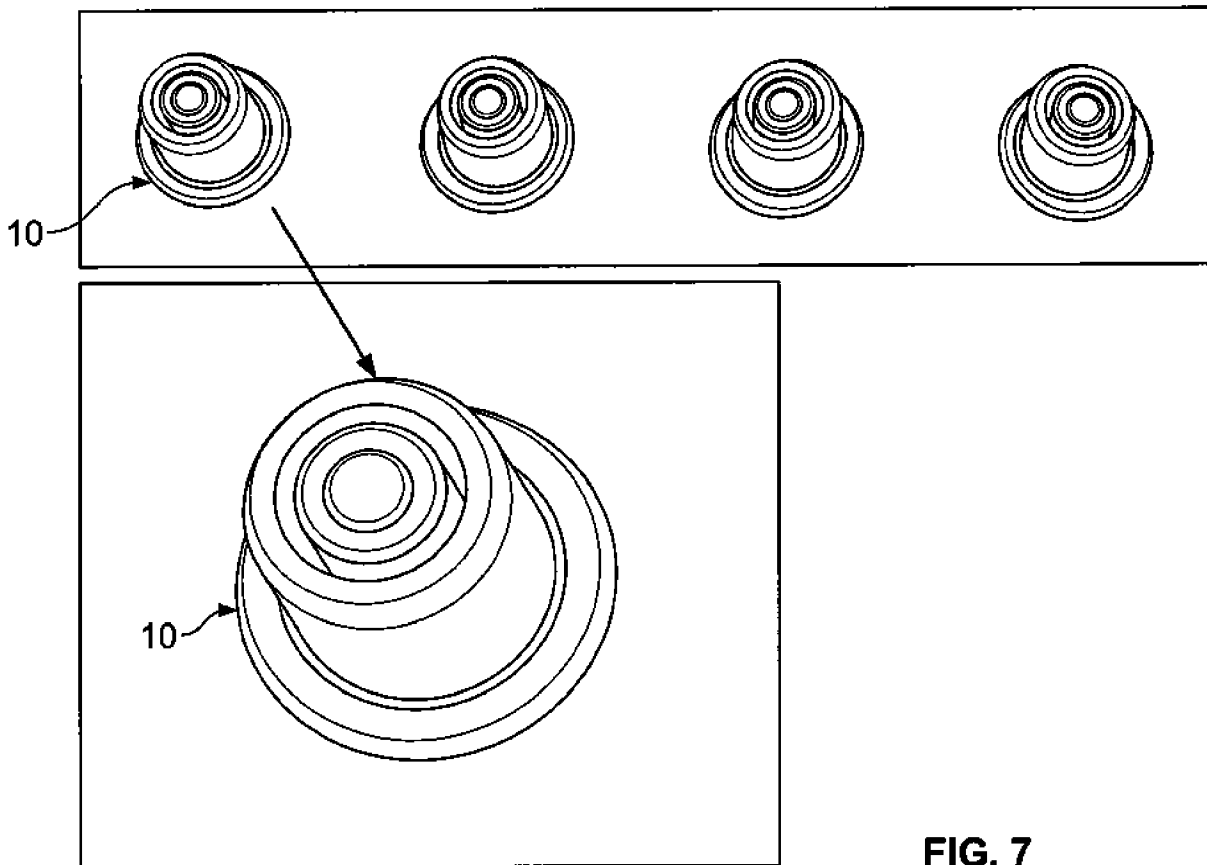

FIG. 7

**INTERNATIONAL SEARCH REPORT**

International application No  
PCT/US2012/030099

A. CLASSIFICATION OF SUBJECT MATTER  
 INV. F16B19/05 F16B33/00 F16B43/00  
 ADD.  
 According to International Patent Classification (IPC) or to both national classification and IPC

B. FIELDS SEARCHED  
 Minimum documentation searched (classification system followed by classification symbols)  
 F16B

Documentation searched other than minimum documentation to the extent that such documents are included in the fields searched

Electronic data base consulted during the international search (name of data base and, where practicable, search terms used)  
 EPO-Internal, WPI Data

**C. DOCUMENTS CONSIDERED TO BE RELEVANT**

Category*	Citation of document, with indication, where appropriate, of the relevant passages	Relevant to claim No.
X	US 2004/234358 A1 (GENICK RAYMOND [US]) 25 November 2004 (2004-11-25) abstract paragraph [0018] - paragraph [0028]; figure 2 claim 3	1
X	GB 1 331 460 A (SIMMONDS SA) 26 September 1973 (1973-09-26) figure 1	1
A	US 4 348 140 A (BERGHOLZ HELMUT ET AL) 7 September 1982 (1982-09-07) the whole document	1-18
A	DE 197 25 329 A1 (ZAHNRADFABRIK FRIEDRICHSHAFEN [DE]) 24 December 1998 (1998-12-24) the whole document	1-18

Further documents are listed in the continuation of Box C.

See patent family annex.

\* Special categories of cited documents :

- "A" document defining the general state of the art which is not considered to be of particular relevance
- "E" earlier application or patent but published on or after the international filing date
- "L" document which may throw doubts on priority claim(s) or which is cited to establish the publication date of another citation or other special reason (as specified)
- "O" document referring to an oral disclosure, use, exhibition or other means
- "P" document published prior to the international filing date but later than the priority date claimed

- "T" later document published after the international filing date or priority date and not in conflict with the application but cited to understand the principle or theory underlying the invention
- "X" document of particular relevance; the claimed invention cannot be considered novel or cannot be considered to involve an inventive step when the document is taken alone
- "Y" document of particular relevance; the claimed invention cannot be considered to involve an inventive step when the document is combined with one or more other such documents, such combination being obvious to a person skilled in the art
- "&" document member of the same patent family

Date of the actual completion of the international search  
 31 May 2012

Date of mailing of the international search report  
 11/06/2012

Name and mailing address of the ISA/  
 European Patent Office, P.B. 5818 Patentlaan 2  
 NL - 2280 HV Rijswijk  
 Tel. (+31-70) 340-2040,  
 Fax: (+31-70) 340-3016

Authorized officer  
 Huusom, Carsten

**INTERNATIONAL SEARCH REPORT**

Information on patent family members

International application No

PCT/US2012/030099

Patent document cited in search report	Publication date	Patent family member(s)	Publication date
US 2004234358	A1	25-11-2004	NONE
-----			
GB 1331460	A	26-09-1973	FR 2071515 A5 17-09-1971
			GB 1331460 A 26-09-1973
-----			
US 4348140	A	07-09-1982	FR 2407383 A1 25-05-1979
			GB 2006907 A 10-05-1979
			US 4348140 A 07-09-1982
-----			
DE 19725329	A1	24-12-1998	NONE
-----			