



(12) **DEMANDE DE BREVET CANADIEN
CANADIAN PATENT APPLICATION**

(13) **A1**

(22) Date de dépôt/Filing Date: 2018/10/09

(41) Mise à la disp. pub./Open to Public Insp.: 2019/11/15

(30) Priorité/Priority: 2018/05/15 (CN201820724023.0)

(51) Cl.Int./Int.Cl. *A24F 47/00* (2006.01)

(71) Demandeur/Applicant:
SHENZHEN IVPS TECHNOLOGY CO., LTD., CN

(72) Inventeur/Inventor:
OUYANG, JUNWEI, CN

(74) Agent: CAMERON IP

(54) Titre : ATOMISEUR ET CIGARETTE ELECTRONIQUE COMPORTANT LEDIT ATOMISEUR

(54) Title: ATOMIZER AND ELECTRONIC CIGARETTE HAVING SAME

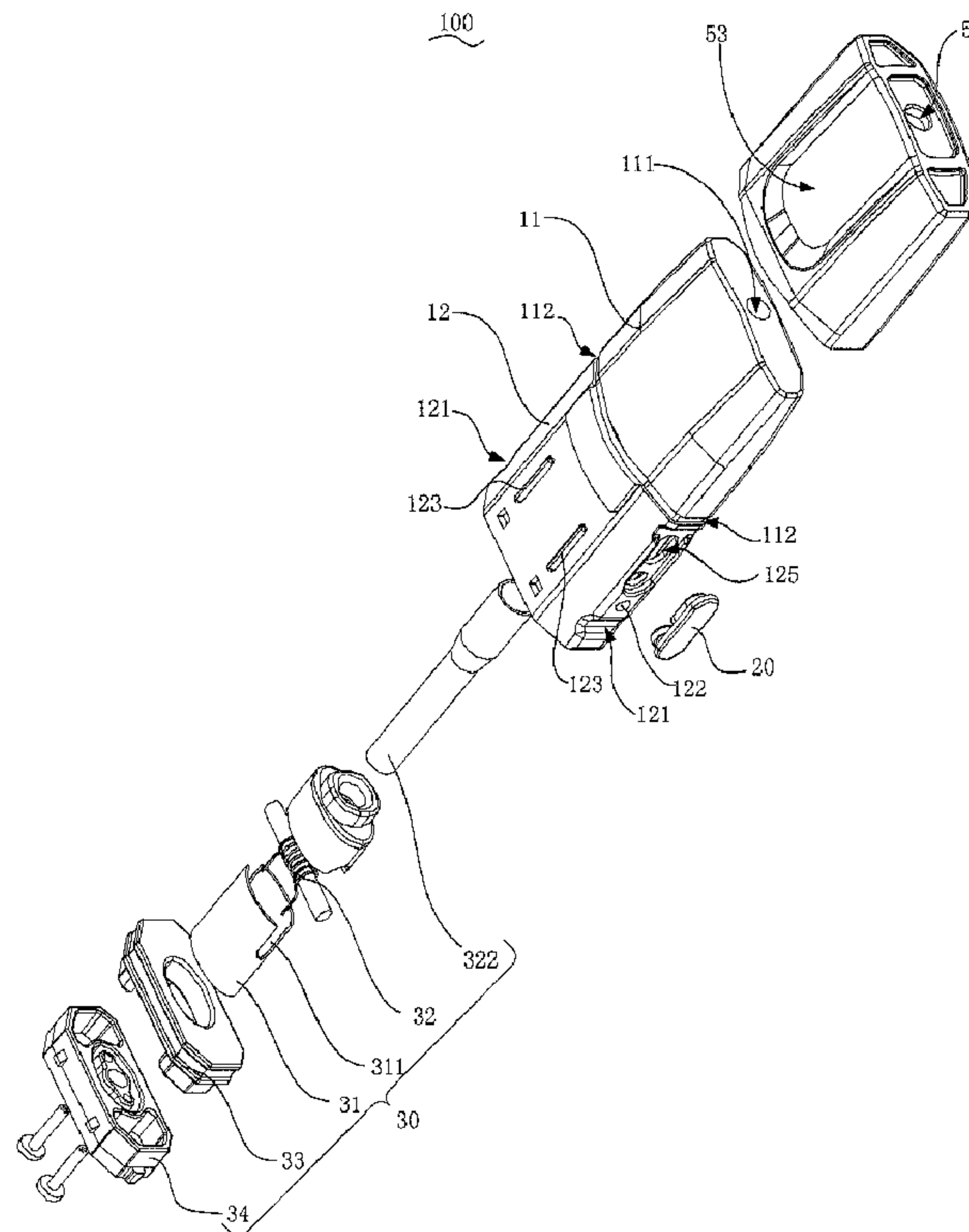

(57) Abrégé/Abstract:

The invention discloses an atomizer and an electronic cigarette applying the atomizer. The atomizer is detachably mounted on a power supply base, the power supply base is provided with a receiving chamber, the atomizer comprises a main body, an

(57) **Abrégé(suite)/Abstract(continued):**

atomizing component and a flexible protective sleeve, the main body is provided with an air inlet, an oil storage chamber, a suction part provided with an air outlet, and an inserting part for being inserted into the receiving chamber, the main body forms an airflow passage between the air inlet and the air outlet, the atomizing component is provided in the airflow passage and is communicated with the oil storage chamber, and the protective sleeve is sleeved on the outer surface of the suction part and is provided with a suction opening communicated with the air outlet. The technical solution of the invention effectively prevents mouth from being scalded and enhances the experience and interest of the user when smoking.

ABSTRACT

The invention discloses an atomizer and an electronic cigarette applying the atomizer. The atomizer is detachably mounted on a power supply base, the power supply base is provided with a receiving chamber, the atomizer comprises a main body, an atomizing component and a flexible protective sleeve, the main body is provided with an air inlet, an oil storage chamber, a suction part provided with an air outlet, and an inserting part for being inserted into the receiving chamber, the main body forms an airflow passage between the air inlet and the air outlet, the atomizing component is provided in the airflow passage and is communicated with the oil storage chamber, and the protective sleeve is sleeved on the outer surface of the suction part and is provided with a suction opening communicated with the air outlet. The technical solution of the invention effectively prevents mouth from being scalded and enhances the experience and interest of the user when smoking.

ATOMIZER AND ELECTRONIC CIGARETTE HAVING SAME

TECHNICAL FIELD

[0001] The invention relates to an atomizer and an electronic cigarette applying the atomizer.

BACKGROUND

[0002] Electronic cigarettes, also known as electronic cigarettes, are mainly used to quit smoking and replace conventional cigarettes. It has an appearance and taste similar to conventional cigarettes, and even has more tastes than conventional cigarettes. It can generate smoke, a taste and a feel like conventional cigarettes. Without tar, suspension particles and other harmful components in conventional cigarettes, electronic cigarettes have gradually replaced conventional cigarettes in the market. In particular, small electronic cigarettes are convenient to carry and are popular among consumers.

[0003] In order to reduce the overall size of the product, the existing small electronic cigarette usually integrates the nozzle and the housing of the atomizing component. However, during use, a hard housing with different shapes easily causes the side structure of the nozzle to generate irregular edges and corners so that the user feels uncomfortable when smoking, and when the user smokes, the nozzle temperature is high so as to easily have the phenomenon of getting mouth scalded.

SUMMARY

[0004] The main object of the invention is to provide an atomizer, which is intended to prevent mouth from being scalded and enhance the experience and interest of the user when smoking.

[0005] In order to achieve the above object, the invention provides an atomizer, wherein the atomizer is detachably mounted on a power supply base, the power supply base is provided with a receiving chamber, wherein the atomizer comprises a main body, an atomizing component and a flexible protective sleeve, the main body is

provided with an air inlet, an oil storage chamber, a suction part provided with an air outlet, and an inserting part for being inserted into the receiving chamber, the main body forms an airflow passage between the air inlet and the air outlet, the atomizing component is provided in the airflow passage and is communicated with the oil storage chamber, and the protective sleeve is sleeved on the outer surface of the suction part and is provided with a suction opening communicated with the air outlet.

[0006] Preferably, one of an inner wall of the protective sleeve and an outer surface of the suction part is provided with at least one first connecting part, and the other thereof is provided with at least one second connecting part, and one of the first connecting parts and one of the second connecting parts are cooperatively connected to mount the protective sleeve in the suction part.

[0007] Preferably, the surface of the outer circumference of the protective sleeve is further provided with a gripping part.

[0008] Preferably, one of the surface of the outer circumference of the inserting part and the cavity wall of the inner circumference of the receiving chamber is provided with at least one positioning protrusion, and the other thereof is provided with at least one positioning groove in an obround hole shape, and when the atomizer is inserted into the receiving chamber, one of the positioning protrusions is clamped in the positioning groove, so that the atomizer is fixed to the power supply base.

[0009] Preferably, one of the surface of the outer circumference of the inserting part and the cavity wall of the inner circumference of the receiving chamber is further convexly provided with a plurality of limiting protrusions, and when the atomizer is inserted into the receiving chamber, each of the limiting protrusions abuts against the internal cavity wall of the receiving chamber or the surface of the outer circumference of the inserting part, so that the atomizer is limited to the power supply base.

[0010] Preferably, one of the surface of the outer circumference of the inserting part and the cavity wall of the inner circumference of the receiving chamber is provided with a plurality of supporting ribs, and when the atomizer is inserted into the receiving chamber, each of the supporting ribs abuts against the internal cavity wall of the receiving chamber or the surface of the outer circumference of the inserting part, so

that there is a gap between the surface of the outer circumference of the inserting part and the internal cavity wall of the receiving chamber through which the airflow passes.

[0011] Preferably, the inserting part is of light-transmitting material, and the power supply base is provided with at least one oil observing groove exposing the inserting part.

[0012] Preferably, one of the inserting part and the power supply base is further provided with a notch groove, and the other thereof is convexly provided with a positioning pin, the inserting part is inserted into the receiving chamber in the direction at which the positioning pin is inserted into the notch groove, and the atomizer is positioned at the power supply base.

[0013] Preferably, the inserting part is further provided with at least one oil-filling hole communicated with the oil storage chamber and at least one oil sealing plug, and one end of the oil sealing plug is pluggably mounted in the oil filling hole for blocking or opening the oil filling hole.

[0014] The invention further provides an electronic cigarette, comprising: an atomizer and a power supply base supplying power to the atomizer 100, wherein the atomizer is detachably mounted on a power supply base, the power supply base is provided with a receiving chamber, wherein the atomizer comprises a main body, an atomizing component and a flexible protective sleeve, the main body is provided with an air inlet, an oil storage chamber, a suction part provided with an air outlet, and an inserting part for being inserted into the receiving chamber, the main body forms an airflow passage between the air inlet and the air outlet, the atomizing component is provided in the airflow passage and is communicated with the oil storage chamber, and the protective sleeve is sleeved on the outer surface of the suction part and is provided with a suction opening communicated with the air outlet.

[0015] According to the atomizer of the technical solution of the invention, the suction part is provided with a flexible protective sleeve, and the flexible protective sleeve is provided with a suction opening communicated with the air outlet for the user to smoke. When the user smokes, the protective sleeve of the flexible material is in direct contact with the oral cavity of the user, effectively preventing the phenomenon

that the suction part having a higher temperature is in direct contact with the oral cavity to get mouth scalded; at the same time, compared with the conventional hard suction part, the flexible protective sleeve has a certain deformation performance, preventing the uncomfortable feeling resulted from the irregular side structure. At the same time, the flexible protective sleeve can be bitten by the user, which effectively enhances the taste and interest of the user.

BRIEF DESCRIPTION OF THE DRAWINGS

[0016] For a better illustration of the embodiments of the invention or the technical solution in the prior art, accompanying drawings needed in the description of the embodiments or the prior art are simply illustrated below. Obviously, the accompanying drawings described below are some embodiments of the invention. For those skilled in the art, other accompanying drawings may be obtained according to the structure shown in these accompanying drawings without creative work.

[0017] FIG. 1 is an exploded schematic diagram illustrating a connecting structure of an atomizer according to the invention;

[0018] FIG. 2 is a perspective schematic diagram illustrating a connecting structure of an atomizer according to the invention;

[0019] FIG. 3 is a perspective schematic diagram illustrating a connecting structure of an atomizer according to the invention from another perspective;

[0020] FIG. 4 is a cross-sectional schematic diagram illustrating a connecting structure of an atomizer according to the invention;

[0021] FIG. 5 is a front schematic diagram illustrating a connecting structure of an electronic cigarette according to the invention;

[0022] FIG. 6 is a partial enlarged schematic diagram illustrating An in FIG. 5 according to the invention;

[0023] FIG. 7 is a schematic diagram illustrating a connecting structure of an atomizer and a power supply base according to the invention.

[0024] Description of the reference numbers:

Reference number	Name of part	Reference	Name of part
------------------	--------------	-----------	--------------

		number	
100	atomizer	311	oil guiding hole
10	main body	312	atomizing chamber
11	suction part	32	heat generating core
111	air outlet	322	air guiding tube
112	first connecting part	33	sealing member
12	inserting part	34	atomizing base
121	positioning groove	50	protective sleeve
122	limiting protrusion	51	suction opening
123	supporting rib	52	second connecting part
124	positioning pin	53	gripping part
125	oil filling hole	200	power supply base
126	air inlet	210	receiving chamber
13	oil storage chamber	2101	positioning protrusion
20	oil sealing plug	211	notch groove
30	atomizing component	222	oil observing groove
31	atomizing shell	1000	electronic cigarette

[0025] The implementation of aims, the function features and the advantages of the present disclosure are described below in further detail in conjunction with embodiments with reference to the drawings.

DESCRIPTION OF THE EMBODIMENTS

[0026] A clear and complete description as below is provided for the technical solution in the embodiments of the invention in conjunction with the drawings in the embodiments of the invention. Obviously, the embodiments described hereafter are simply part embodiments of the invention, rather than all the embodiments. All other

embodiments obtained by those skilled in the art based on the embodiments in the invention without creative work are intended to be included in the scope of protection of the invention.

[0027] It should be noted that all directional indications (such as top, bottom, left, right, front, behind...) in the embodiments of the invention are merely to illustrate a relative position relation, a relative motion condition, etc. between each part in a certain state (for example, the state shown in the drawings). If the state changes, the directional indication changes accordingly.

[0028] In addition, if terms "first", "second", etc. appear in the invention, they are merely for the purpose of description, but cannot be understood as the indication or implication of relative importance or as the implicit indication of the number of the designated technical features; therefore, features defined by "first" and "second" may specifically or implicitly comprise at least one such feature. In addition, technical solutions of each embodiment of the invention may be combined mutually; however, this must be carried out on the basis that those skilled in the art can implement the combination. When the combination of technical solutions has a conflict or cannot be implemented, it should be considered that such combination of technical solutions does not exist and is not in the scope of protection claimed by the invention.

[0029] In the invention, unless otherwise specifically stated and defined, terms "connected", "fixed", etc. should be interpreted expansively. For example, "fixed" may be fixed connection, detachable connection, or integration; may be mechanical connection or electrical connection; direct connection, indirect connection through an intermediate, or internal communication between two elements or interaction of two elements, unless otherwise specifically defined. Those skilled in the art can understand the specific implication of the above terms in the invention according to specific conditions.

[0030] The invention provides an electronic cigarette 1000. The electronic cigarette 1000 comprises an atomizer 100 and a power supply base 200 supplying power to the atomizer 100. The power supply base 200 is provided with a mounting chamber in which the atomizer 100 is mounted. The power supply base 200 is provided with a

recyclable battery and a control circuit. When the atomizer 100 is mounted in the mounting chamber, the power supply base 200 is electrically connected to the atomizer 100 so as to supply power to the atomizing component 30, so that the atomizing component 30 heats the tobacco liquid to generate smoke for the user to smoke, thereby giving the user a smoking experience. The power supply component may also be provided with an operating indicator and an inserting terminal. The inserting terminal may use a micro jack, a lighting jack or a Type c jack for charging and data transmission.

[0031] Referring to FIG. 1 to FIG. 7, in the embodiment of the invention, the atomizer 100 is detachably mounted on a power supply base 200, the power supply base 200 is provided with a receiving chamber 210, wherein the atomizer 100 comprises a main body 10, an atomizing component 30 and a flexible protective sleeve 50, the main body 10 is provided with an air inlet 126, an oil storage chamber 13, a suction part 11 provided with an air outlet 111, and an inserting part 12 for being inserted into the receiving chamber 210, the main body 10 forms an airflow passage between the air inlet 126 and the air outlet 111, the atomizing component 30 is provided in the airflow passage and is communicated with the oil storage chamber 13, and the protective sleeve 50 is sleeved on the outer surface of the suction part 11 and is provided with a suction opening 51 communicated with the air outlet 111.

[0032] According to the atomizer 100 of the technical solution of the invention, the suction part 11 is provided with a flexible protective sleeve 50 which is made of non-toxic silicone material, and the flexible protective sleeve 50 is provided with a suction opening 51 communicated with the air outlet 111 for the user to smoke. When the user smokes, the protective sleeve 50 of the flexible material is in direct contact with the oral cavity of the user, effectively preventing the phenomenon that the suction part 11 having a higher temperature is in direct contact with the oral cavity to get mouth scalded; at the same time, compared with the conventional hard suction part 11, the flexible protective sleeve 50 has a certain deformation performance, preventing the uncomfortable feeling resulted from the irregular side structure. At the same time, the protective sleeve 50 made of non-toxic silicone material can be bitten

by the user with the taste of biting nipples, effectively improving the taste that the user bites hard material and enhancing the interest.

[0033] Specifically, as shown in FIG. 4, in the embodiment of the invention, one of an inner wall of the protective cover 50 and an outer surface of the suction part 11 is provided with at least one first connecting part 112, and the other thereof is provided with at least one second connecting part 52, and one of the first connecting parts 112 and one of the second connecting parts 52 are cooperatively connected to mount the protective cover 50 in the suction part 11. Here, in the present embodiment, the inner circumference of the end of the protective sleeve 50 is convexly provided with a limiting flange to form the second connecting part 52. Further, the outer circumference of the suction part 11 is correspondingly provided with an annular groove to form the first connecting part 112. When the protective sleeve 50 is sleeved on the suction part 11, the limiting flange is buckled in the annular groove, and the protective sleeve 50 is fixed to the suction part 11, effectively preventing the phenomenon that the protective sleeve 50 falls off.

[0034] It is to be understood that, in practical applications, the first connecting part 112 and the second connecting part 52 are not limited to the manner in which the limiting flange and the annular groove are used in the above embodiment. For example, in another embodiment of the invention, the manner in which the protective sleeve 50 and the suction part 11 may be fixed by means of a buckle, a snap fastener or a glue, etc., falls within the scope of protection of the invention. Similarly, the number and position of the first connecting part 112 and the second connecting part 52 are not limited to being provided at the end of the protective sleeve 50 in the above embodiment. For example, a plurality of first connecting parts 112 and second connecting parts 52 may be appropriately provided depending on the size of the product, and may be provided at intervals between the protective sleeve 50 and the suction part 11.

[0035] Further, as shown in FIG. 1 to FIG. 3, in the embodiment of the invention, the surface of the outer circumference of the protective cover 50 is further provided with a gripping part 53. Here, in the present embodiment, the gripping part 53 is formed by

providing inclined grooves on the opposite surfaces of the outer circumference of the protective sleeve 50, effectively facilitating the user to grip the atomizer 100 to be pulled out from the receiving chamber 210 provided by the power supply base 200.

[0036] Further, as shown in FIG. 1 to FIG. 4 and FIG. 6, in the embodiment of the invention, one of the surface of the outer circumference of the inserting part 12 and the cavity wall of the inner circumference of the receiving chamber 210 is provided with at least one positioning protrusion 2101, and the other thereof is provided with at least one positioning groove 121 in an obround hole shape, and when the atomizer 100 is inserted into the receiving chamber 210, one of the positioning protrusions 2101 is clamped in the positioning groove 121, so that the atomizer 100 is fixed to the power supply base 200. Here, in the present embodiment, the internal cavity wall of the receiving chamber 210 is convexly provided with two positioning protrusions 2101. The two positioning protrusions 2101 are convexly provided in the two opposite internal cavity walls of the receiving chamber 210. The outer peripheral edge of the main body 10 is correspondingly provided with two positioning grooves 121 in an obround hole shape. Two side groove walls in the width direction of the positioning groove 121 in an obround hole shape abuts against the side structure of the positioning protrusion 2101, and the length extends in the circumferential direction of the receiving chamber 210. When the main body 10 of the atomizer 100 is inserted into the receiving chamber 210, the two positioning protrusions 2101 are clamped in the positioning groove 121, so that the main body 10 of the atomizer 100 is fixed to the power supply base 200, effectively preventing the phenomenon that a circular positioning groove 121 is provided conventionally, and when the mounting accuracy is poor, the positioning protrusion 2101 cannot be smoothly clamped in the positioning groove 121 so as to result in unstable mounting.

[0037] It is to be understood that, in practical applications, the shape of the positioning groove 121 is only limited to the manner of using an obround hole as described above. For example, in another embodiment of the invention, the manner in which the positioning groove 121 may also extend in a long distance in the length direction to form a through groove falls within the scope of protection of the invention.

[0038] Further, as shown in FIG. 1 to FIG. 3, in the embodiment of the invention, one of the surface of the outer circumference of the inserting part 12 and the cavity wall of the inner circumference of the receiving chamber 210 is further convexly provided with a plurality of limiting protrusions 122, and when the atomizer 100 is inserted into the receiving chamber 210, each of the limiting protrusions 122 abuts against the internal cavity wall of the receiving chamber 210 or the surface of the outer circumference of the inserting part 12, so that the atomizer 100 is limited to the power supply base 200. Here, for example, the surface of the outer circumference of the inserting part 12 is provided with a plurality of limiting protrusions 122. When the atomizer 100 is inserted into the receiving chamber 210, the protrusions 122 which are convexly provided abut against the internal cavity wall of the receiving chamber 210 so as to be closely fit, effectively preventing the phenomenon that the atomizer 100 shakes when the atomizer 100 is mounted in the receiving chamber 210. At the same time, there is still a gap between the outer wall of the inserting part 12 where the limiting protrusion 122 is not provided and the receiving chamber 210 through which the airflow passes, without affecting the working air intake of the main body 10 when the user smokes.

[0039] Further, as shown in FIG. 1 to FIG. 3, in the embodiment of the invention, one of the surface of the outer circumference of the inserting part 12 and the cavity wall of the inner circumference of the receiving chamber 210 is provided with a plurality of supporting ribs 123, and when the atomizer 100 is inserted into the receiving chamber 210, each of the supporting ribs 123 abuts against the internal cavity wall of the receiving chamber 210 or the surface of the outer circumference of the inserting part 12, so that there is a gap between the surface of the outer circumference of the inserting part 12 and the internal cavity wall of the receiving chamber 210 through which the airflow passes. Here, in the embodiment, the outer peripheral edge of the inserting part 12 is provided with four supporting ribs 123 extending in the axial direction of the receiving chamber 210. Every two supporting ribs 123 are provided at the outer wall of one side of the inserting part 12 at intervals. When the inserting part 12 is inserted into the receiving chamber 210, the supporting rib 123 abuts against the internal cavity wall of the receiving chamber 210, further effectively preventing the

phenomenon that the atomizer 100 shakes when being mounted in the receiving chamber 210. At the same time, a supporting space is formed between the two supporting ribs 123, through which the airflow passes, effectively ensuring the working air intake of the atomizer 100 when the user smokes, and preventing the phenomenon that the occurrence of labored breathing results in dry burning of the atomizer 100 due to the fact that the gap between the surface of the outer circumference of the inserting part 12 and the internal cavity wall of the receiving chamber 210 is too small.

[0040] Specifically, as shown in FIG. 3 or FIG. 7, in the embodiment of the invention, the inserting part 12 is of light-transmitting material, and the power supply base 200 is provided with at least one oil observing groove 222 exposing the inserting part 12. Here, in the present embodiment, the two opposite side walls of the power supply base 200 are both provided with a through groove exposing the inserting part 12 to form the oil observing groove 222, which facilitates the user to observe the residual amount of tobacco liquid in the oil storage chamber 13. Further, the inserting part 12 is correspondingly provided with a bump inserted into the oil observing groove 222, preventing the phenomenon that external dust enters the receiving chamber 210 from the oil observing groove 222.

[0041] It is to be understood that, in practical applications, it is not limited to the manner in which the power supply base 200 is provided with a through groove to form the oil observing groove 222 in the above embodiment. For example, the manner in which the power supply base 200 is partially made of light-transmitting material so as to expose the internal receiving chamber 210 falls within the scope of protection of the invention.

[0042] Further, as shown in FIG. 7, in the embodiment of the invention, one of the inserting part 12 and the power supply base 200 is further provided with a notch groove 211, and the other thereof is convexly provided with a positioning pin 124, the inserting part 12 is inserted into the receiving chamber 210 in the direction at which the positioning pin 124 is inserted into the notch groove 211, and the atomizer 100 is positioned at the power supply base 200. Here, in the embodiment, the positioning pin 124 and the notch groove 211 are provided to realize guiding orientation, effectively

preventing the phenomenon that when the user inserts the receiving chamber 210 from another angle, the receiving chamber 210 cannot be inserted due to the abutment, or the phenomenon of an electrode reverse connection or a short circuit

[0043] It is to be understood that, in practical applications, the manner in which an oil observing groove 222 is provided on one surface of the power supply base 200 so as to distinguish the inserting direction as described above and perform guiding orientation also falls within the scope of protection of the invention.

[0044] Further, as shown in FIG. 1 or FIG. 4, in the embodiment of the invention, the inserting part 12 is further provided with at least one oil filling hole 125 communicated with the oil storage chamber 13 and at least one oil sealing plug 20, and one end of the oil sealing plug 20 is pluggably mounted in the oil filling hole 125 for blocking or opening the oil filling hole 125. Here, in the embodiment, the inserting part 12 is provided with an oil filling hole 125, and then is provided with an oil sealing plug 20 made of an elastic silicone material, so that the user may supplement the oil in the oil storage chamber 13, preventing the phenomenon that direct replacement of the atomizer 100 leads to higher use cost; at the same time, when the inserting part 12 is inserted into the receiving chamber 210, the oil filling hole 125 is covered, effectively preventing the phenomenon that the oil sealing plug 20 is accidentally opened so as to result in oil leakage.

[0045] Specifically, as shown in FIG. 1, in the embodiment of the invention, the main body 10 comprises a base 34 provided with an air inlet 126 and a housing covering the base 34 and provided with an air outlet 111. An oil storage chamber 13 is encircled between the housing and the base 34. The atomizing component 30 comprises an atomizing shell 31 and a heat generating core 32. The atomizing shell 31 covers the base 34 and encircles an atomizing chamber 312 together with the base 34. The atomizing shell 31 is further provided with an oil guiding hole 311 and an air guiding tube 322. The oil guiding hole 311 is communicated with the oil storage chamber 13 and the atomizing chamber 312. The air guiding tube 322 is communicated with the atomizing chamber 312 and the air outlet 111. The atomizing chamber 312 is communicated with the air inlet 126 and the air outlet 111. The heat

generating core 32 is received in the atomizing chamber 312 and is partially exposed from the base 34. Here, in the present embodiment, when the housing is inserted into the receiving chamber 210, an airflow passage is formed between the outer peripheral edge of the housing and the internal cavity wall of the receiving chamber 210. The air inlet 126 is provided at the base 34. The limiting protrusion 122, the positioning protrusion 2101 and the supporting rib are provided on each surface of the inserting part 12, effectively preventing the housing from shaking, and at the same time, ensuring that the external airflow can enter the atomizing chamber 312 through the air inlet 126 after flowing into the airflow passage when the user smokes. The atomizing shell 31 covers the base 34, and encircles an atomizing chamber 312 communicated with the oil storage chamber 13 together with the base 34. The heat generating core 32 is received in the atomizing chamber 312 and is partially exposed from the base 34 to form a contact electrode. When the main body 10 of the atomizer 100 is inserted into the receiving chamber 210, the main body 10 abuts against the output electrode of the power supply base 200 and forms an electrical circuit. When the user smokes, the power supply base 200 drives the heat generating core 32 to heat the tobacco liquid adsorbed by the heat generating core 32 from the oil storage chamber 13 to atomize the tobacco liquid into smoke. At the same time, the external airflow flows into the atomizing chamber 312 through the air inlet 126, and the atomized smoke is mixed and discharged from the air outlet 111 for the user to smoke.

[0046] Further, as shown in FIG. 1 or FIG. 4, in the embodiment of the invention, the main body 10 further comprises a sealing member 33. One end of the sealing member 33 is fixedly mounted on the base 34, and the other end thereof is received in the oil storage chamber 13 and is closely fitted with the inner peripheral edge of the housing. Here, in the embodiment, the base 34 is provided with two inserting grooves, and the sealing member 33 is provided with two inserting posts and an avoiding vacancy into which the sleeve is inserted. One of the inserting posts is inserted into the one of the inserting grooves. When the sealing member 33 is fixed to the base 34, the outer peripheral edge of the sealing member 33 is closely fitted with the inner wall of the housing, while wrapping the outer peripheral edge of sleeve close to the base 34,

preventing the phenomenon that oil leaks from the gap among the sealing member 33, the base 34 and the housing.

[0047] Referring to FIG. 7, the invention further provides an electronic cigarette 1000. The electronic cigarette 1000 comprises a power supply base 200 and an atomizer 100. Refer to the above embodiment for the specific structure of the atomizer 100. Due to the use of all the technical solutions of all the above embodiments, the electronic cigarette 1000 has at least all the beneficial effects brought by the technical solutions of the above embodiments, which will not be described in detail herein.

[0048] The above are preferred embodiments of the invention merely and are not intended to limit the patent scope of the invention. Any equivalent structures made according to the description and the accompanying drawings of the invention without departing from the idea of the invention, or any equivalent structures applied in other relevant technical fields directly or indirectly are intended to be included in the patent protection scope of the invention.

CLAIMS

1. An atomizer, wherein the atomizer (100) is detachably mounted on a power supply base (200), the power supply base (200) is provided with a receiving chamber (210), wherein the atomizer (100) comprises a main body (10), an atomizing component (30) and a flexible protective sleeve (50), the main body (10) is provided with an air inlet (126), an oil storage chamber (13), a suction part (11) provided with an air outlet (111), and an inserting part (12) for being inserted into the receiving chamber (210), the main body (10) forms an airflow passage between the air inlet (126) and the air outlet (111), the atomizing component (30) is provided in the airflow passage and is communicated with the oil storage chamber (13), and the protective sleeve (50) is sleeved on an outer surface of the suction part (11) and is provided with a suction opening (51) communicated with the air outlet (111).
2. The atomizer according to claim 1, wherein one of an inner wall of the protective sleeve (50) and an outer surface of the suction part (11) is provided with at least one first connecting part (112), and the other thereof is provided with at least one second connecting part (52), and one of the first connecting parts (112) and one of the second connecting parts (52) are cooperatively connected to mount the protective sleeve (50) in the suction part (11).
3. The atomizer according to claim 1, wherein the surface of the outer circumference of the protective sleeve (50) is further provided with a gripping part (53).
4. The atomizer according to claim 1, wherein one of the surface of the outer circumference of the inserting part (12) and the cavity wall of the inner circumference of the receiving chamber (210) is provided with at least one positioning protrusion (2101), and the other thereof is provided with at least one positioning groove (121) in an obround hole shape, and when the atomizer (100) is inserted into the receiving chamber (210), one of the positioning protrusions (2101) is clamped in the positioning groove (121), so that the atomizer (100) is fixed to the power supply base (200).

5. The atomizer according to any one of claims 1 to 4, wherein one of the surface of the outer circumference of the inserting part (12) and the cavity wall of the inner circumference of the receiving chamber (210) is further convexly provided with a plurality of limiting protrusions (122), and when the atomizer (100) is inserted into the receiving chamber (210), each of the limiting protrusions (122) abuts against the internal cavity wall of the receiving chamber (210) or the surface of the outer circumference of the inserting part (12), so that the atomizer (100) is limited to the power supply base (200).

6. The atomizer according to any one of claims 1 to 4, wherein one of the surface of the outer circumference of the inserting part (12) and the cavity wall of the inner circumference of the receiving chamber (210) is provided with a plurality of supporting ribs (123), and when the atomizer (100) is inserted into the receiving chamber (210), each of the supporting ribs (123) abuts against the internal cavity wall of the receiving chamber (210) or the surface of the outer circumference of the inserting part (12), so that there is a gap between the surface of the outer circumference of the inserting part (12) and the internal cavity wall of the receiving chamber (210) through which the airflow passes.

7. The atomizer according to claim 1, wherein the inserting part (12) is of light-transmitting material, and the power supply base (200) is provided with at least one oil observing groove (222) exposing the inserting part (12).

8. The atomizer according to claim 1, wherein one of the inserting part (12) and the power supply base (200) is further provided with a notch groove (211), and the other thereof is convexly provided with a positioning pin (124), the inserting part (12) is inserted into the receiving chamber (210) in the direction at which the positioning pin (124) is inserted into the notch groove (211), and the atomizer (100) is positioned at the power supply base (200).

9. The atomizer according to claim 1, wherein the inserting part (12) is further provided with at least one oil filling hole (125) communicated with the oil storage chamber (13) and at least one oil sealing plug (20), and one end of the oil sealing plug (20) is pluggably mounted in the oil filling hole (125) for blocking or opening the oil filling hole (125).

10. An electronic cigarette, comprising: a power supply base (200) and the atomizer (100) according to any one of claims 1 to 9, wherein the power supply base (200) is fixedly connected to the atomizer (100) and is configured for supplying power to the atomizer (100).

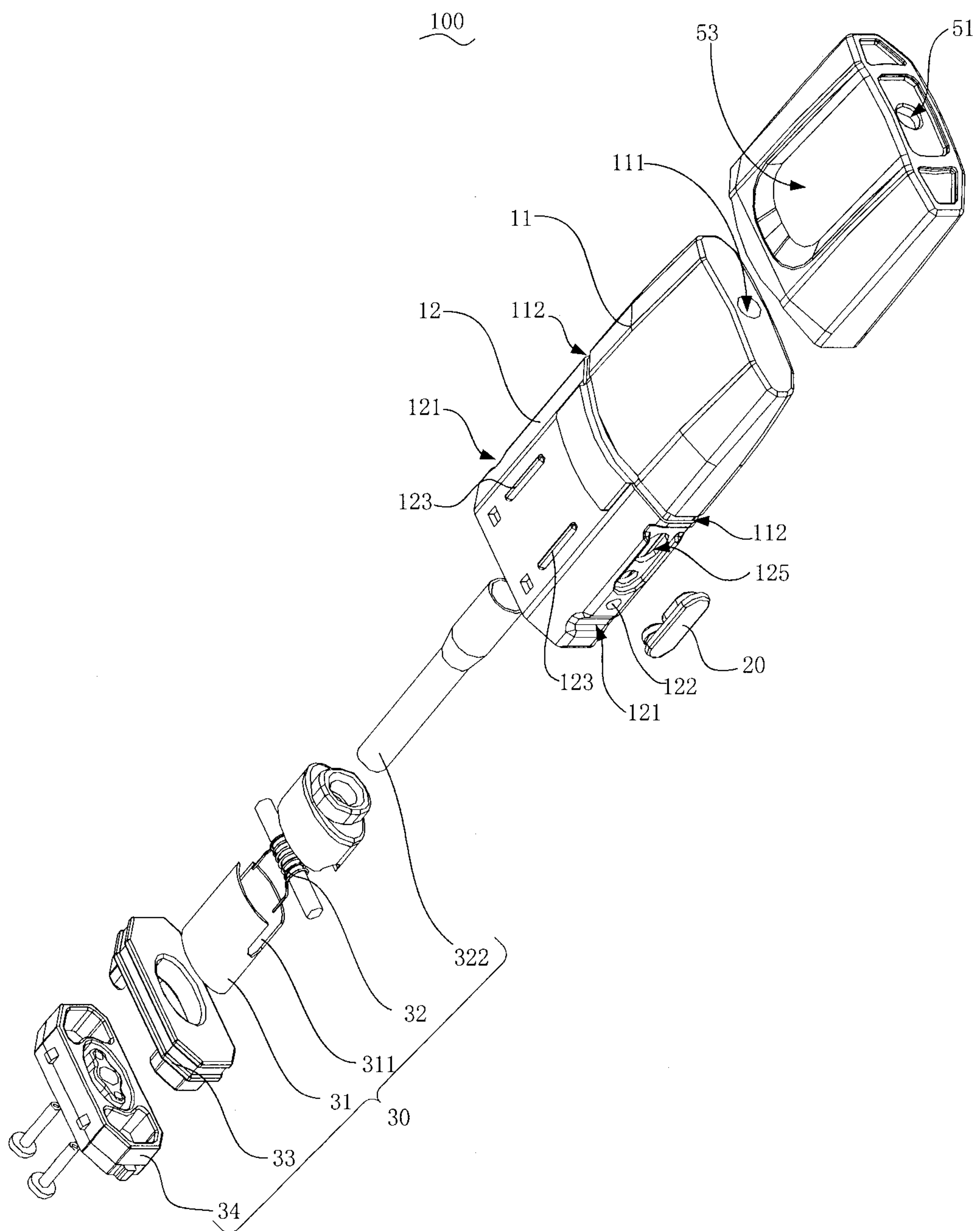

FIG. 1

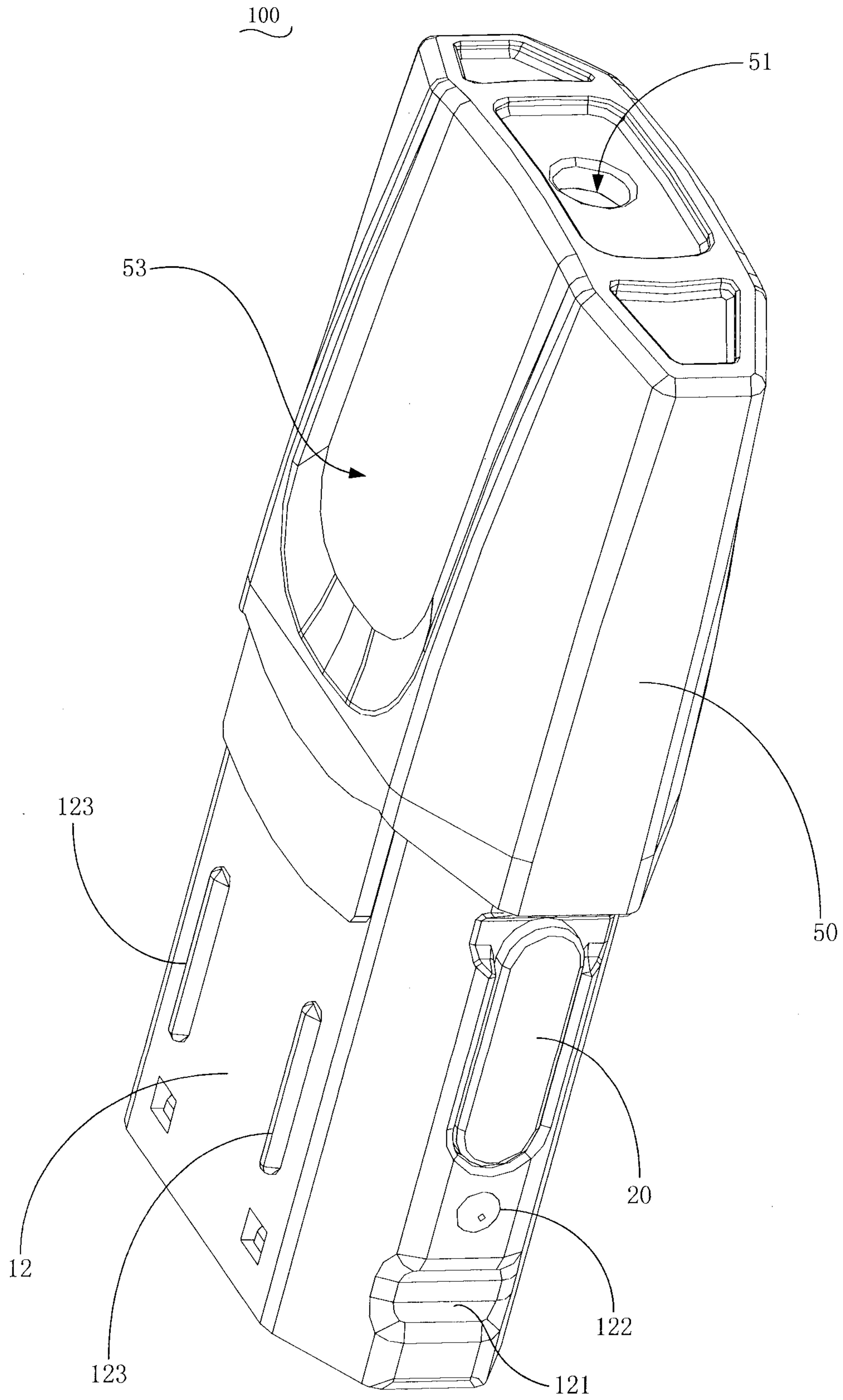

FIG. 2

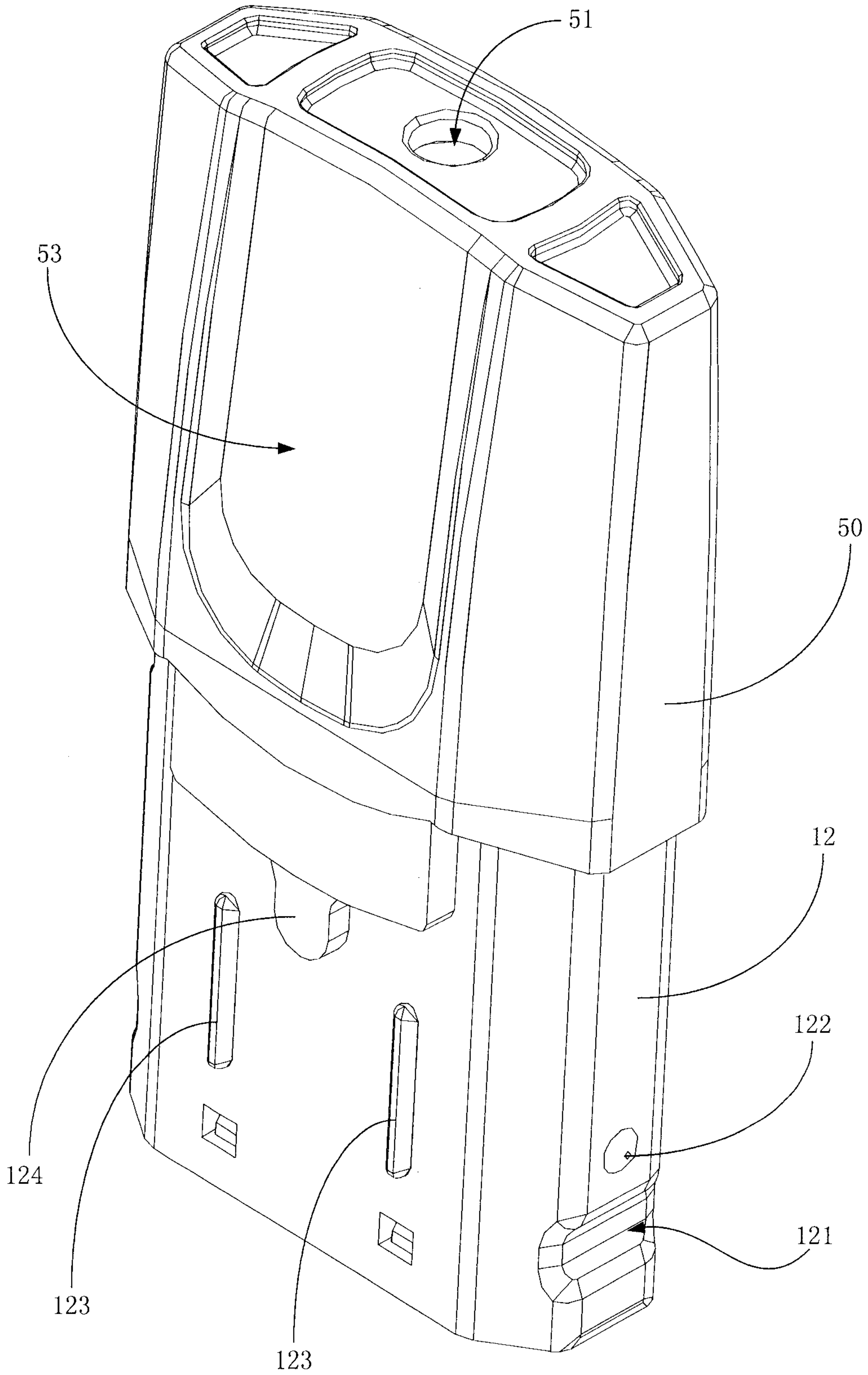

FIG. 3

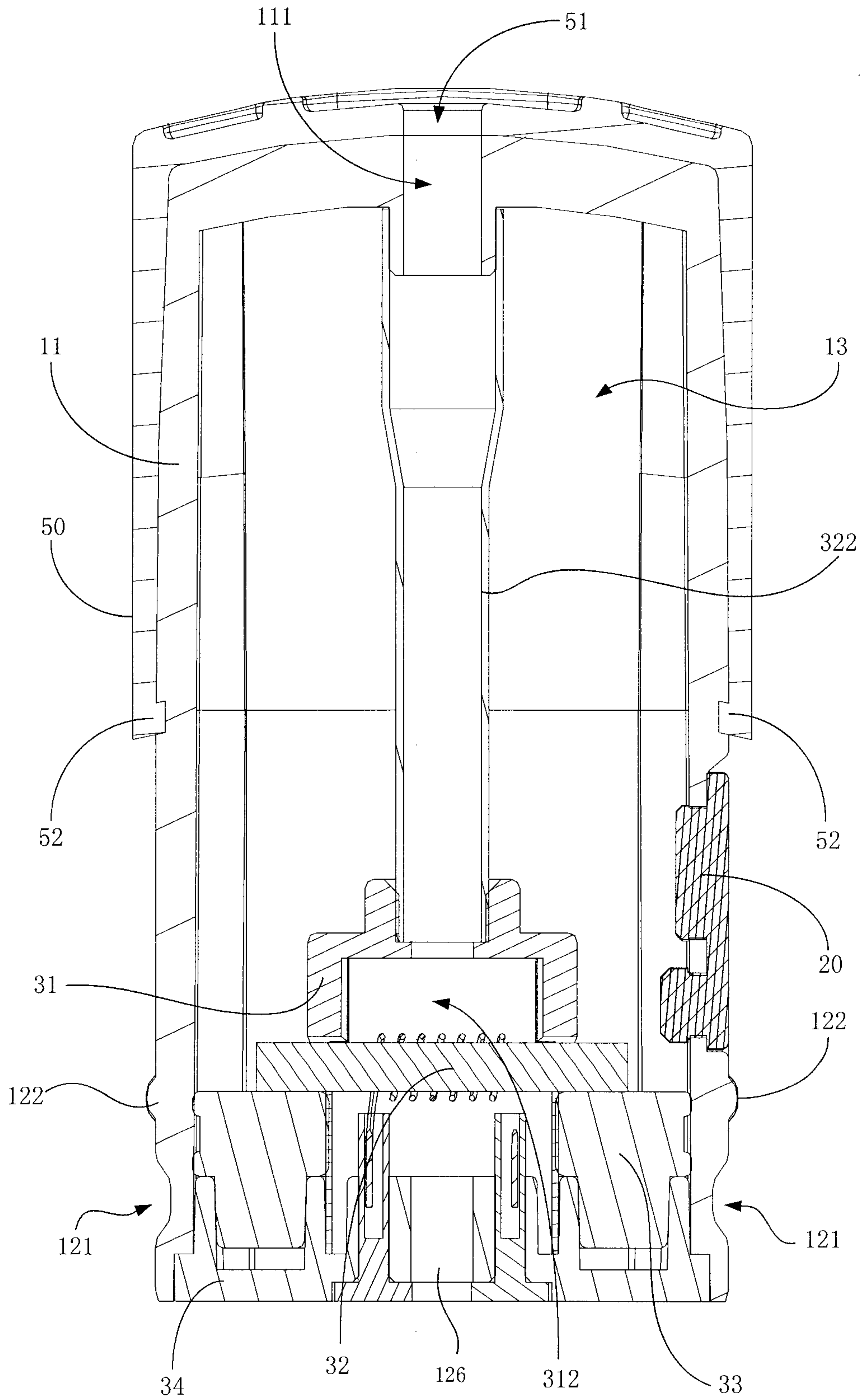

FIG. 4

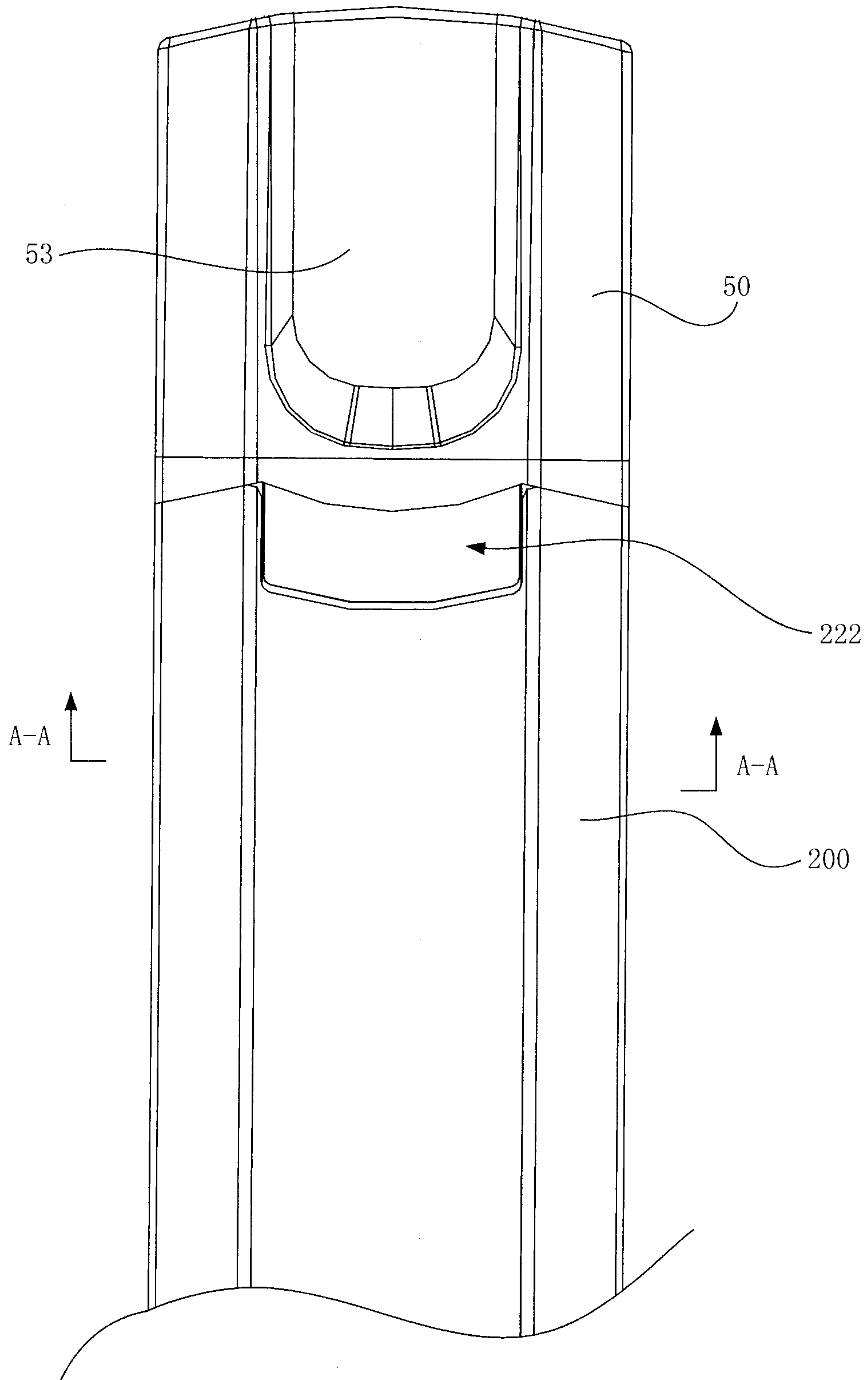

FIG. 5

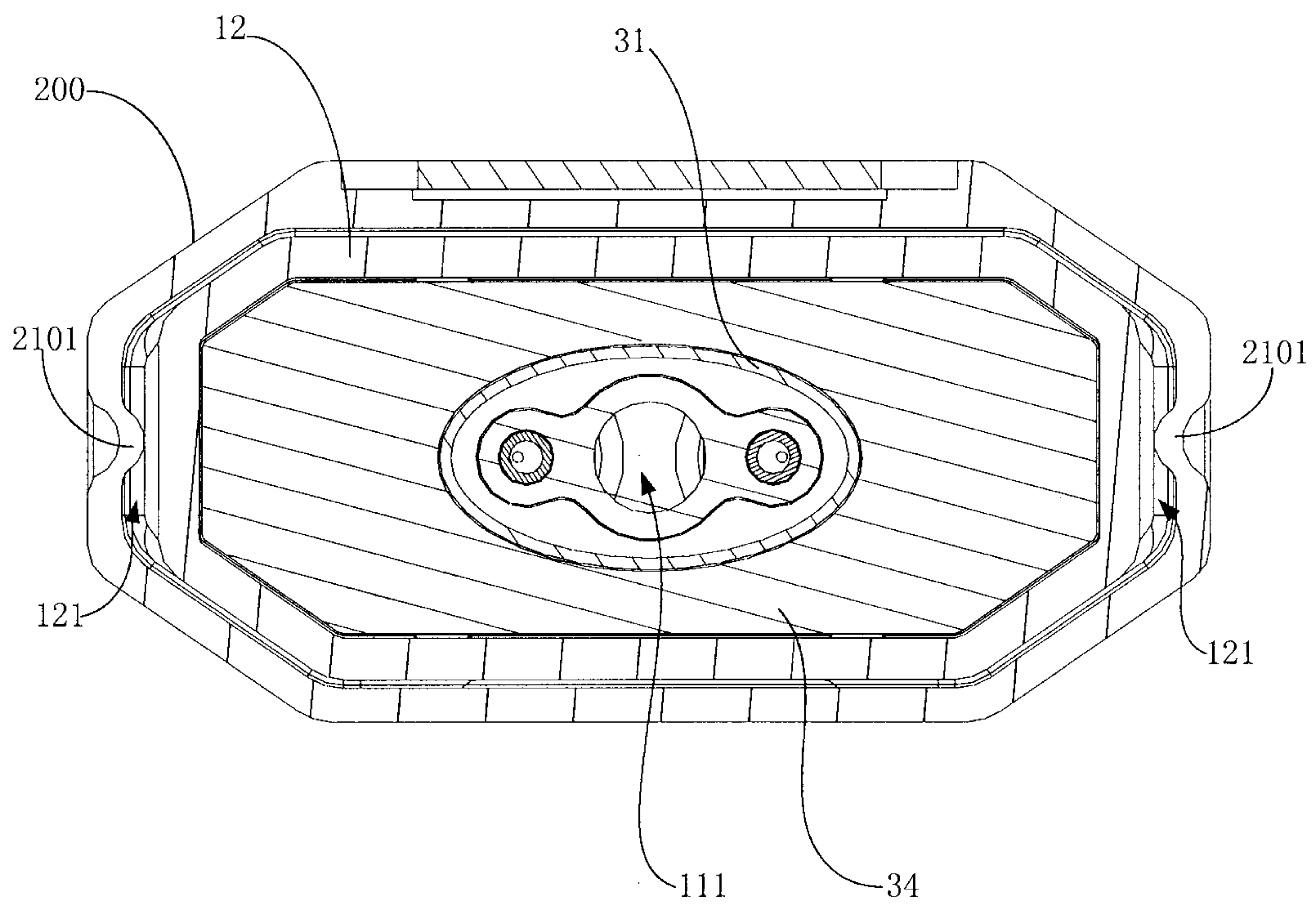

FIG. 6

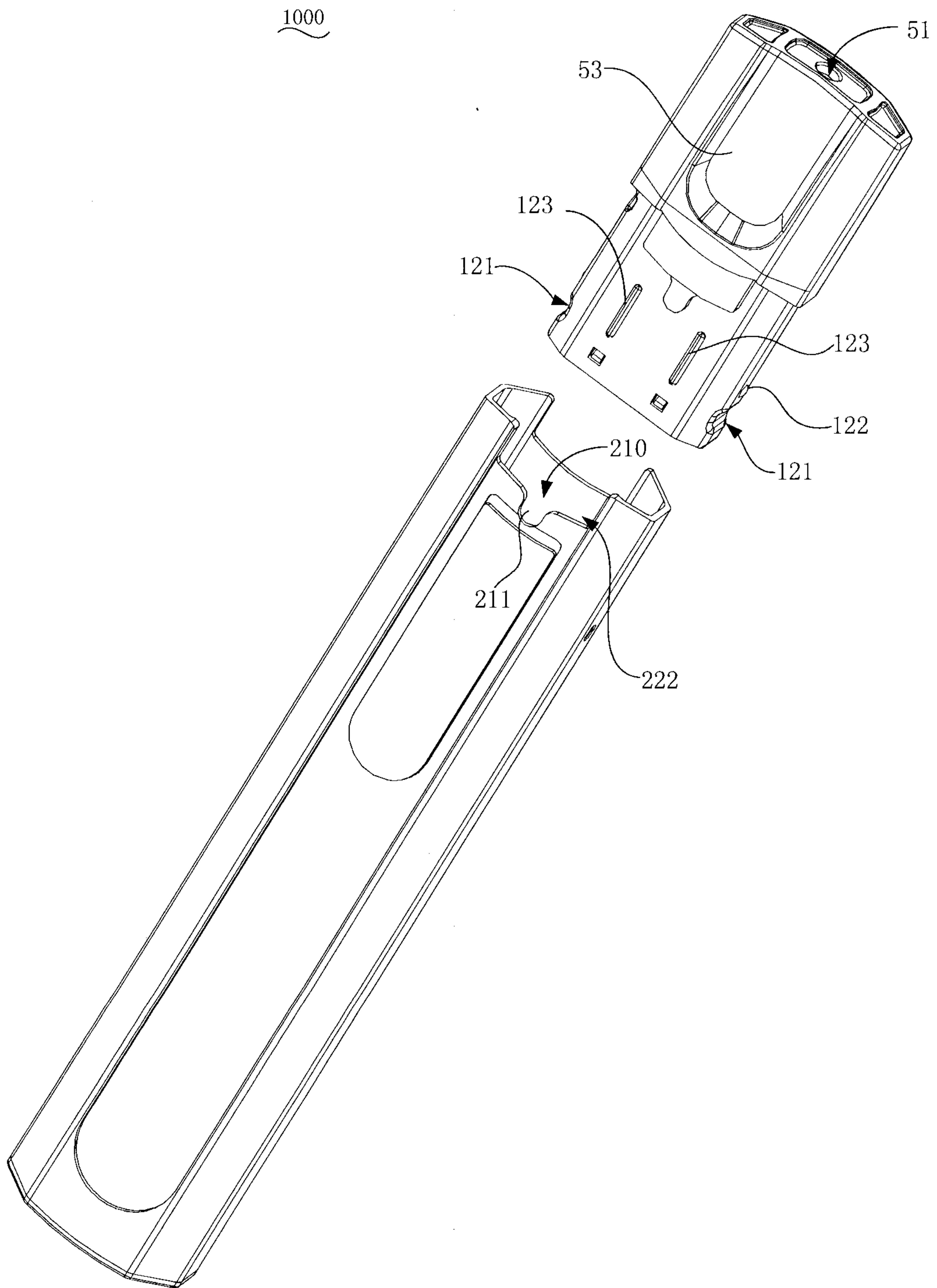

FIG. 7

