



- (51) International Patent Classification:  
A47J 43/28 (2006.01) G01F 19/00 (2006.01)
- (21) International Application Number:  
PCT/US2011/064236
- (22) International Filing Date:  
9 December 2011 (09.12.2011)
- (25) Filing Language: English
- (26) Publication Language: English
- (30) Priority Data:  
61/426,924 23 December 2010 (23.12.2010) US
- (71) Applicant (for all designated States except US): **ABBOTT LABORATORIES** [US/US]; 100 Abbott Park Road, Dept. 0377 AP6A-1, Abbott Park, Illinois 60064 (US).
- (72) Inventors; and
- (75) Inventors/Applicants (for US only): **ULSTAD, David Carl** [US/US]; 5556 Caplestone Lane, Dublin, Ohio 43017 (US). **HEO, Youngsuk** [KR/US]; 7319 Scioto Chase Blvd., Powell, Ohio 43065 (US).
- (74) Agents: **ENGLE, Mark R.** et al.; Abbott Nutrition, a Division of Abbott Laboratories, 3300 Stelzer Road, Dept 108140 RP3-2, Columbus, Ohio 43219 (US).

- (81) Designated States (unless otherwise indicated, for every kind of national protection available): AE, AG, AL, AM, AO, AT, AU, AZ, BA, BB, BG, BH, BR, BW, BY, BZ, CA, CH, CL, CN, CO, CR, CU, CZ, DE, DK, DM, DO, DZ, EC, EE, EG, ES, FI, GB, GD, GE, GH, GM, GT, HN, HR, HU, ID, IL, IN, IS, JP, KE, KG, KM, KN, KP, KR, KZ, LA, LC, LK, LR, LS, LT, LU, LY, MA, MD, ME, MG, MK, MN, MW, MX, MY, MZ, NA, NG, NI, NO, NZ, OM, PE, PG, PH, PL, PT, QA, RO, RS, RU, RW, SC, SD, SE, SG, SK, SL, SM, ST, SV, SY, TH, TJ, TM, TN, TR, TT, TZ, UA, UG, US, UZ, VC, VN, ZA, ZM, ZW.
- (84) Designated States (unless otherwise indicated, for every kind of regional protection available): ARIPO (BW, GH, GM, KE, LR, LS, MW, MZ, NA, RW, SD, SL, SZ, TZ, UG, ZM, ZW), Eurasian (AM, AZ, BY, KG, KZ, MD, RU, TJ, TM), European (AL, AT, BE, BG, CH, CY, CZ, DE, DK, EE, ES, FI, FR, GB, GR, HR, HU, IE, IS, IT, LT, LU, LV, MC, MK, MT, NL, NO, PL, PT, RO, RS, SE, SI, SK, SM, TR), OAPI (BF, BJ, CF, CG, CI, CM, GA, GN, GQ, GW, ML, MR, NE, SN, TD, TG).

Published:  
— with international search report (Art. 21(3))

(54) Title: DISPENSING MEMBER FOR DISPENSING POWDERED BEVERAGE PRODUCT

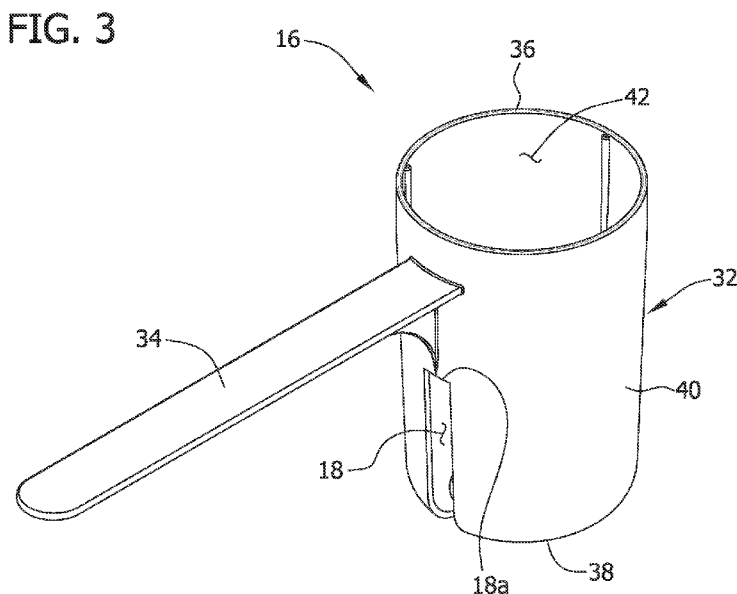

(57) Abstract: In a dispensing member for dispensing powdered nutritional beverage from a container, a receptacle for holding the powdered nutritional beverage has an open top, a bottom, and a sidewall extending therebetween to together define an interior space for holding the powdered nutritional beverage. The receptacle has an imaginary axis lengthwise along the sidewall from the bottom to the top of the receptacle. A handle is attached to and extends at least in part transversely outward from the receptacle, with the handle having an imaginary longitudinal axis that intersects the imaginary axis of the receptacle at a handle - intersecting location. At least one air vent, such as one or more elongate slot or a plurality of openings, extends through the sidewall of the receptacle to the interior space of the receptacle, with the at least one air vent being disposed entirely within a circumferential air-venting portion of the sidewall.



DISPENSING MEMBER FOR DISPENSING  
POWDERED BEVERAGE PRODUCT

[0001] This application claims priority to U.S. Provisional Application No. 61/426,924, filed December 23, 2010, the disclosure of which is incorporated by reference herein in its entirety.

FIELD OF THE DISCLOSURE

[0002] The present disclosure relates generally to a dispensing member for dispensing a powdered beverage product.

BACKGROUND

[0001] Powdered beverage product, such as a reconstitutable powdered beverage, may be packaged in a container. A dispensing member, such as a typical measuring cup or scoop, may be provided with or even in the container to facilitate dispensing of the powdered beverage product in predetermined quantities or doses. Such dispensing members more specifically often include a cup or receptacle intended to hold a predetermined quantity of the powdered beverage product, and a handle extending outward from the receptacle for gripping by the user. To dispense a quantity of the powdered beverage product from the container, a user will typically hold the handle of the dispensing member and move the receptacle through the powdered beverage product to scoop the beverage product into the receptacle.

[0002] The conventional scoop-type dispensing member is a quick and relatively easy way for a user to dispense powdered beverage product from a container. One drawback associated with these scoop-type dispensing members is the formation of air pockets in the receptacle (e.g., behind the powder entering and filling the dispenser) as the receptacle is scooping the powdered beverage product – thus trapping air in the receptacle along with the powder. This formation of air pockets leads to imprecise and inaccurate measuring and dispensing of the beverage product. In particular, the air pockets may lead a user, through no fault of his/her own, to scoop a quantity of beverage product that is significantly less than the desired or intended quantity. These measuring errors may be particularly troublesome when dispensing powdered nutritional beverages because such

beverages typically contain specific ratios of nutrients per serving to provide a certain nutritional benefit. Thus, the dispensing errors may lead to the consumer not obtaining the full, intended nutritional benefit of the beverage.

[0003] Moreover, in some situations the consumer may realize that air pockets have formed in the dispensing member. In response, the consumer may tap down or compact the nutritional beverage product in the dispensing member. This then requires the user to go back and add additional powder to the scoop to fully fill the receptacle, or it may lead to the consumer overly packing the powder in the receptacle, thus dispensing a larger quantity of nutritional beverage product than intended.

## SUMMARY

[0004] In one embodiment, a package of powdered beverage product generally comprises a container having an interior space, and a quantity of nutritional powdered beverage in the interior space of the container. A dispensing member is provided for dispensing a quantity of the powdered nutritional beverage from the interior space of the container. The dispensing member includes a receptacle for holding the quantity of the powdered nutritional beverage, the receptacle having an open top, a bottom, and a sidewall extending therebetween such that the open top, the bottom and the sidewall together define an interior space for holding the powdered nutritional beverage in the receptacle. The receptacle has an imaginary axis lengthwise along the sidewall from the bottom to the top of the receptacle. A handle is attached to and extends at least in part transversely outward from the receptacle, with the handle having an imaginary longitudinal axis. The imaginary axis of the receptacle intersects the imaginary axis of the handle at a handle-intersecting location. The receptacle sidewall has an air-venting portion extending circumferentially up to and including about 45 degrees about the receptacle from the imaginary axis thereof. At least one air vent extends through the sidewall of the receptacle to the interior space of the receptacle, with the at least one air vent being disposed entirely within the air-venting portion of the sidewall.

[0005] In another embodiment, a dispensing member for use in dispensing a quantity of powdered beverage product generally comprises a receptacle for holding a quantity of the powdered beverage. The receptacle has an open top, a bottom, and a sidewall extending therebetween such that the open top, the bottom and the sidewall

together define an interior space for holding the powdered beverage in the receptacle. The receptacle has an imaginary axis lengthwise along the sidewall from the bottom to the top of the receptacle. A handle is attached to and extends at least in part transversely outward from the receptacle, with the handle having an imaginary longitudinal axis. The imaginary axis of the receptacle intersects the imaginary axis of the handle at a handle-intersecting location. The receptacle sidewall has an air-venting portion extending circumferentially up to and including about 45 degrees about the receptacle from the imaginary axis thereof. At least one air vent extends through the sidewall of the receptacle to the interior space of the receptacle, with the at least one air vent being disposed entirely within the air-venting portion of the sidewall.

[0006] In yet another embodiment, a dispensing member for use in dispensing a quantity of powdered beverage product generally comprises a receptacle for holding a quantity of the powdered beverage. The receptacle has an open top, a bottom, and a sidewall extending therebetween such that the open top, the bottom and the sidewall together define an interior space for holding the powdered beverage in the receptacle. The sidewall of the receptacle has an elongate slot disposed therein. A handle is attached to and extends transversely outward from the receptacle.

[0007] In still another embodiment, a dispensing member for use in dispensing a quantity of powdered beverage product generally comprises a receptacle for holding a quantity of the powdered beverage. The receptacle has an open top, a bottom, and a sidewall extending therebetween such that the open top, the bottom and the sidewall together define an interior space for holding the powdered beverage in the receptacle. A handle is attached to and extends transversely outward from the receptacle. The sidewall of the receptacle has a plurality of openings therein in spaced relationship with each other, at least one half of the plurality of openings being disposed in the sidewall circumferentially within 45 degrees of a line extending longitudinally along the sidewall and intersecting the handle.

[0008] In another embodiment, a dispensing member for use in dispensing a quantity of powdered beverage product generally comprises a receptacle for holding a quantity of the powdered beverage. The receptacle has an open top, a bottom, and a sidewall extending therebetween such that the open top, the bottom and the sidewall

together define an interior space for holding the powdered beverage in the receptacle. A handle is attached to and extends transversely outward from the receptacle. The sidewall of the receptacle has at least one air vent disposed in the sidewall of the receptacle, with the air vent being sized and located on the sidewall such that the air vent corresponds to a predetermined quantity of powdered beverage that is less than a full capacity of the receptacle.

#### BRIEF DESCRIPTION OF THE DRAWINGS

[0009] Figure 1 is a perspective of an embodiment of a package of powdered beverage product including a first embodiment of a dispensing member for dispensing the powdered beverage product from the package;

[0010] Figure 2 is a fragmentary view of the package of Fig. 1, the package being in an open configuration;

[0011] Figure 3 is a rear perspective of the first embodiment of the dispensing member;

[0012] Figure 4 is a top plan view of the first embodiment of the dispensing member of Figure 3;

[0013] Figure 5 is a rear elevation of the first embodiment of the dispensing member of Figure 3;

[0014] Figure 6 is a rear perspective of a second embodiment of a dispensing member;

[0015] Figure 7 is a top plan view of the second embodiment of the dispensing member of Figure 6; and

[0016] Figure 8 is a rear elevation of the second embodiment of the dispensing member of Figure 6.

[0017] Corresponding reference characters indicate corresponding parts throughout the drawings.

## DETAILED DESCRIPTION OF THE DRAWINGS

[0018] Referring now to the drawings and in particular to Figs. 1 and 2, one embodiment of a package of powdered beverage product is generally indicated at 10. The illustrated package 10 generally includes a container 12, a quantity of powdered beverage product 14 in the container, and a dispensing member, generally indicated at 16, also packaged in the container. As explained in more detail below, the illustrated dispensing member 16 facilitates dispensing of a predetermined or selected quantity of the powdered beverage product, and has at least one air vent 18 configured to facilitate more precise and more accurate metering and dispensing of the powdered beverage product 14.

[0019] The illustrated container 12 is an exemplary container suitable for a powdered beverage. The container 12 has an open top 22, interior space 24, and a lid 26 that selectively closes the open top. As initially packaged, the dispensing member 16 may be received in the container 12, such as by being secured to an inner surface of the lid 26 by a securement component, generally indicated at 28, or otherwise loosely disposed in the interior space 24, although the dispensing member 16 may be packaged in other ways, including exterior of the container. As initially packaged, the open top 22 may be further sealed by a removable seal, such as a foil seal (not shown). The container 12 may be made from plastic or metal or another suitable material. Moreover, the illustrated lid 26 is removable from the container 12, although in some embodiments, the lid may be hingedly secured to the open top 22 for selectively opening and closing the open top. It is understood that the container 12 may have other configurations without departing from the scope of the present invention.

[0020] The powdered beverage product 14 may, in one embodiment, include a powdered nutritional beverage comprising one or more of fat, protein and carbohydrate. Such powdered beverages include high fat nutritional powdered beverages, non-limiting examples of which include infant formula powder (e.g., Similac® brand formula from Abbott Laboratories, Abbott Park, Illinois, USA), as well as follow-on or toddler powders and adult nutritional powders (e.g., Ensure® Powder, also available from Abbott Laboratories, Abbott Park, Illinois, USA).

[0021] The term “high fat powdered beverage” as used herein, unless otherwise specified, means a powder that may be reconstituted with water or other aqueous liquid to form a beverage, wherein the powder has a total fat content that represents from at least about 5%, including from about 5% to about 50%, also including from about 8% to about 30%, and also including from about 10% to about 25%, by weight of the powder. High fat powders typically further comprise one or more of carbohydrate and protein. Such powdered beverage may be prepared by any known or otherwise suitable method in the nutrition art, including dry mixing or blending, spray drying, and others. The high fat nutritional powdered beverage may further comprise vitamins, minerals, active ingredients, excipients, and or other nutritional ingredients.

[0022] Suitable fat for the “high fat powdered beverage” as used herein may include coconut oil, soy oil, corn oil, olive oil, safflower oil, high oleic safflower oil, MCT oil (medium chain triglycerides), sunflower oil, high oleic sunflower oil, palm and palm kernel oils, palm olein, canola oil, marine oils, cottonseed oils, and combinations thereof, or any other fat suitable for use in a nutritional product. The term “fat” as used herein includes any lipid material, including fats, oils, and combinations thereof.

[0023] Carbohydrates suitable for use in the high fat nutritional powdered beverage may include simple or complex carbohydrates, lactose-containing or lactose-free, or combinations thereof, non-limiting examples of which include hydrolyzed, intact, naturally and/or chemically modified cornstarch, maltodextrin, glucose polymers, sucrose, corn syrup, corn syrup solids, rice or potato derived carbohydrate, glucose, fructose, lactose, high fructose corn syrup and indigestible oligosaccharides such as fructooligosaccharides (FOS), and combinations thereof. The high fat nutritional powdered beverage may comprise from 0 to 95%, including from 1% to 90%, and also including from 10% to 85%, of a suitable carbohydrate by weight of the powder.

[0024] Proteins suitable for use in the high fat nutritional powdered beverage may include hydrolyzed, partially hydrolyzed or non-hydrolyzed proteins or other protein sources, and can be derived from any known or otherwise suitable source such as milk (e.g., casein, whey), animal (e.g., meat, fish), cereal (e.g., rice, corn), vegetable (e.g., soy), or combinations thereof. The proteins may include free amino acids. The high fat

nutritional powdered beverage be may comprise from 0 to 95%, including from 1% to 90%, and also including from 10% to 50%, of a suitable protein by weight of the powder.

[0025] The powdered beverage product may alternatively comprise energy drinks, sports drinks, milk or protein based compositions, or other nutritional beverages available in a powdered form. In other embodiments, the powdered beverage product 14 may be a non-nutritive beverage such as a flavored soft drink or other powdered beverage that is reconstituted with an aqueous liquid such as water, fruit juice, and so forth to prepare the desired beverage. The powdered beverage product as described herein is typically in the form of particulates, most typically flowable particulates which may be fine or granular or any combination thereof and may be of uniform or irregular shapes.

[0026] Referring now to Figs. 3-5, the dispensing member 16 of the illustrated embodiment is generally in the form of a scoop including a generally cylindrical receptacle (otherwise referred to as a cup or a bowl), generally indicated at 32, and a handle 34 attached to and extending outward from the receptacle. The receptacle 32 has an open top 36, a closed bottom 38, a sidewall 40 extending between the open top and the closed bottom, and a height H (Fig. 5) extending from the bottom to the open top. Together, the open top 36, the bottom 38 and the sidewall 40 define an interior space 42 for holding the powdered beverage product upon dispensing. As seen in Figs. 4 and 5, the interior space 42 of the receptacle 32 has an imaginary axis A1 extending along the height H of the receptacle, and the sidewall 40 has a circumference extending 360 degrees around the imaginary axis of the interior space. The interior space 42 is sized to hold a predetermined or target quantity of the powdered beverage product 14. The amount, by volume and/or mass, of the target quantity may vary according to the type of beverage product. In one example, the height H of the receptacle 32 may be within a range of about 30 mm (1.18 in) to about 40 mm (1.57 in). But the receptacle 32 may be of other suitable shapes and sizes within the scope of this invention.

[0027] The illustrated handle 34 is joined to the receptacle 32 generally adjacent to the open top 36, although the handle may be joined adjacent to the bottom 38 or at another location. As seen in Fig. 4, the handle 34 has an imaginary axis A2 intersecting the receptacle 32, and more particularly the sidewall 40, at a handle-intersecting location HL. The handle 34 and the receptacle 32 may be formed integrally as a one-piece

construction, or the handle and the receptacle may be formed separately and secured to one another in a suitable way. Moreover, the illustrated handle 34 is generally thin and elongate, although the handle may have other configurations without departing from the scope of the present invention.

[0028] Referring still to Figs. 3-5, as disclosed above, the illustrated dispensing member 30 has at least one air vent 18 configured to facilitate more precise and more accurate metering and dispensing of the powdered beverage product 14. In the illustrated embodiment of Figs. 3-5, a slot-shaped air vent 18 extends through the sidewall 40 of the receptacle 32 to the interior space 42. The slot-shaped air vent 32 has a length L extending generally along the height H of the receptacle 32 from generally adjacent the intersecting location HL of the handle 34 to the bottom 38 of the receptacle. The length L of the slot-shaped air vent 18 according to one embodiment may measure from about 10 mm (0.39 in) to about 30 mm (1.18 in), and more specifically, may measure about 20 mm (0.79 in), although the length may generally depend on the height H of the receptacle. For example, the length L of the slot-shaped air vent 18 in one embodiment may measure about 20% to about 90% of the height H of the receptacle 32, though other ratios of the length of the slot-shaped air vent to the height of the receptacle do not depart from the scope of the present invention.

[0029] The slot-shaped air vent 18 also has a width W across the slot. The width W as used herein refers to the tangential width across the slot at the inner surface of the receptacle sidewall 40. The width W of the air vent 18 according to one embodiment may be within a range of about 1 mm (0.04 in) to about 6 mm (0.24 in), more suitably, within a range of about 2 mm (0.08 in) to about 5 mm (0.20 in), and in one suitable non-limiting example, about 4 mm (0.16 in). The width W of the slot-shaped air vent 18 may be of another measurement without departing from the scope of the present invention.

[0030] In the illustrated embodiment, the one or more slot-shaped air vents 18 is/are disposed entirely within a circumferential air-venting portion 46 of the sidewall 40. In one embodiment, the air-venting portion 46 may comprise a circumferential extent of the sidewall 40 extending less than or equal to about 90 degrees around the imaginary axis A1 of the interior space 42. More suitably, the air-venting portion 46 of the sidewall 40 may have a circumference extending less than or equal to

about 45 degrees about the imaginary axis A1 of the interior space 42 in both circumferential directions from the handle-intersecting location HL. In other embodiments, the air-venting portion 46 of the sidewall 40 may extend circumferentially less than or equal to about 30 degrees, or less than or equal to about 15 degrees, or less than or equal to about 10 degrees, or less than or equal to about 5 degrees, or less than or equal to about 3 degrees, or less than or equal to about 1 degree, about the imaginary axis A1 of the interior space 42 in both circumferential directions from the handle-intersecting location HL.

[0031] In the illustrated embodiment, for example, at least a portion of the slot-shaped air vent 18 is in substantial alignment with the handle-intersecting location HL along the height H of the receptacle 32, such as generally at zero degrees about the imaginary axis A1 from the handle-intersecting location HL. It is understood, however, that even if a single slot-shaped air vent 18 is present, the air vent may be other than at zero degrees about the imaginary axis A1 as long as it is within the air-venting portion 46 of the sidewall 40. In this manner, when the dispensing member 16 is oriented with the handle generally upright out of the container (e.g., so that the receptacle is generally horizontal for scooping powder therein), the air vent 18 is generally in a location where air tends to become trapped in the receptacle so as to facilitate venting of the air. In other embodiments where multiple slot-shaped air vents 18 are present, one of the vents, or none of the vents, may be disposed at the zero degrees location about the imaginary axis A1, as long as multiple air vents are disposed within the air-venting portion 46 of the sidewall 40.

[0032] In the particularly suitable embodiment illustrated in Figs. 3-5, a remainder of the sidewall 40, having a circumference outside the circumference of the air-venting portion 46, is free from additional air vents. That is, other than the air-venting portion 46, the sidewall 40 of the receptacle does not have air vents. It is understood, however, that the remainder of the sidewall 40 may include air vents without departing from the scope of the present invention. Although not shown in the illustrated embodiment, in addition to the illustrated slot-shaped air vent 18, the receptacle 32 may have one or more additional slot-shaped air vents and/or one or more air vents of a different configuration within and/or outside the air-venting portion 46.

[0033] Referring to Figs. 3 and 5, in the illustrated embodiment the slot-shaped air vent 18 has a longitudinal end 18a at a location along the height H of the receptacle 32 that corresponds to a predetermined quantity of powdered beverage product 14 when the receptacle is filled to the longitudinal end of the air vent. Thus, the slot-shaped air vent 18 can be used as an indicator to facilitate metering of the powdered beverage product 14 to a fraction of the full capacity of the receptacle 32. In particular, the longitudinal end 18a of the slot-shaped air vent 18 in the illustrated embodiment facilitates metering one-half of the full capacity of the receptacle 32. As an example, where the receptacle 32 has a capacity for holding a quantity of powdered beverage product for mixing with 2 ounces of liquid (e.g., water), the illustrated longitudinal end 18a of the slot-shaped air vent 18 is disposed at a location that indicates the predetermined quantity of powdered beverage product 14 for mixing with 1 ounce of liquid (e.g., a quantity of powdered beverage product that is one-half the full capacity of the receptacle).

[0034] It is understood that the slot-shaped air vent 18 may in some embodiments be configured to facilitate metering of the powdered beverage product 14 to fractions of the full capacity of the receptacle 32 other than one-half without departing from the scope of the present invention. Moreover, the receptacle 32 may include more than one slot-shaped air vent 18 to facilitate metering of the powdered beverage product 14 to more than one fraction of the full capacity of the receptacle 32. For example, the receptacle 32 may include three slot-shaped air vents for respectively facilitating metering of the powdered beverage product 14 to three-fourths of the full capacity of the receptacle, one-half of the full capacity of the receptacle, and one-fourth of the full capacity of the receptacle.

[0035] It is also understood that the longitudinal end 18a of the slot-shaped air vent 18 may not be configured to facilitate metering of the powdered beverage product 14 to a fraction of the full capacity of the receptacle 32 without departing from the scope of the present invention. Moreover, multiple slot-shaped air-vents 18 of different lengths and/or widths may be provided without departing from the scope of this invention. Additionally, while the slot-shaped air vent 18 of the illustrated embodiment extends lengthwise of the receptacle sidewall, it is contemplated that in other embodiments one or more slot-shaped air vents may extend circumferentially of the receptacle sidewall – within the air-venting portion 46. For example, each circumferentially extending slot-shaped air

vent, depending on its lengthwise location along the receptacle, may indicate a predetermined quantity of powdered beverage product if filled to the level of the slot-shaped air vent.

[0036] Referring now to Figs. 6-8, another embodiment of a dispensing member is generally indicated at 116. This illustrated embodiment is similar to the first embodiment, and like components are indicated by corresponding reference numerals plus 100. The main difference between the two dispensing members 16, 116 is that this second dispensing member includes a plurality of air vents 118 having other than a slot-shape in the sidewall 140 of the receptacle 132, as opposed to one or more slot-shaped air vents 18. Like the first dispensing member 16, however, the air vents 118 are disposed entirely within a circumferential air-venting portion 146 of the sidewall 140. In one embodiment, the air-venting portion may have a circumference extending less than or equal to about 90 degrees around the imaginary axis of the interior space 142. In particular, the air-venting portion 146 of the sidewall 140 may have a circumference extending less than or equal to about 45 degrees about the imaginary axis A1 of the interior space 142 in both circumferential directions from the handle-intersecting location HL. In other embodiments, the air-venting portion 146 of the sidewall 140 may have a circumference extending less than or equal to about 30 degrees, or less than or equal to about 15 degrees, or less than or equal to about 10 degrees, or less than or equal to about 5 degrees, or less than or equal to about 3 degrees, or less than or equal to about 1 degree, about the imaginary axis A1 of the interior space 142 in both circumferential directions from the handle-intersecting location HL.

[0037] The air vents 118 of the second dispensing member 116 are suitably arranged in a generally triangular pattern on the sidewall. That is, the air vents 118 are arranged in circumferential rows that are spaced apart along the height H of the receptacle 132, with the number of air vents in each row increasing toward the bottom 138 of the receptacle. In the illustrated embodiment, a majority of the air vents 118 are generally adjacent to the bottom 138 of the receptacle 132. Also in the illustrated embodiment, the air vents 118 have substantially uniform sizes and shapes. In one non-limiting example, the air vents 118 have generally circular shapes and diameters within a range of about 1 mm (0.04 in) to about 3 mm (0.12 in), and more specifically, about 2 mm (0.08 in). The air vents 118, however, may have other shapes and sizes, with the air vents

being of uniform shape and size, or of different shapes and/or sizes from each other. The air vents 118 may also be arranged in other pattern shapes, or not in a discernible pattern, without departing from the scope of the present invention.

[0038] Similar to the first dispensing member 16, a remainder of the sidewall 140 of the second dispensing member 116, having a circumference outside the circumference of the air-venting portion 146, is free from air vents. That is, other than the air-venting portion 146, the sidewall 140 of the receptacle 132 does not have air vents. Although not shown in the illustrated embodiment, in addition to the air vents 118, the receptacle 132 may have one or more additional air vents and/or one or more air vents of a different configuration such as the slot-shaped air vent 18 of Figs. 3-5.

[0039] The dispensing member 116 of the illustrated embodiment also has three additional air vents 150 extending through the bottom 138 of the receptacle 132, as seen in Fig. 7. These air vents 150 are generally adjacent to air-venting portion 146 of the sidewall 136. The air vents 150 may be similar to the air vents 118 in the sidewall 136 in size and shape, or the air vents may have other shapes and sizes. It is understood, however, that the dispensing member 116 may be free from air vents in the bottom 138 of the receptacle 132 without departing from the scope of the present invention.

[0040] In an exemplary method of metering and dispensing a predetermined quantity of powdered beverage product 14, the user grips the handle 34, 134 of the dispensing member 16, 116, and moves the receptacle 32, 132 through the powdered beverage product 14 in the container 12 to completely fill the receptacle with powdered beverage product. As the receptacle is filled, air that is trapped behind the powdered beverage entering the receptacle is vented through the one or more air vents 18, 118 to facilitate a more complete filling of the receptacle with powder. The metered predetermined quantity of powdered beverage product is then discharged from the receptacle 32, 132 and into a vessel or other container by turning the receptacle upside down.

[0041] In another exemplary method of metering and dispensing a predetermined quantity of powdered beverage product 14, the user grips the handle 34 of the dispensing member 16 and moves the receptacle 32 through the powdered beverage product in the container 12 to fill the receptacle up to the longitudinal end 18a of the slot-

shaped air vent 18. The metered predetermined quantity of powdered beverage product 14 is a fraction (e.g., one-half, or one-fourth, or three-fourths) of the full capacity of the receptacle 32. The metered predetermined quantity of powdered beverage product 14 is then discharged from the receptacle 32 and into a vessel or other container by turning the receptacle upside down.

### **Experimental Results**

[0042] Experimental testing was performed on one example of the dispensing member of the present invention to determine if the dispensing member more accurately and more precisely dispenses powdered beverage product compared to a conventional dispensing member.

[0043] Testing was performed using the following nutritional powdered beverages, all of which are available from Abbott Laboratories, Abbott Park, Illinois, U.S.A.: 1) Similac® Advance®; 2) Similac Sensitive® RS; 3) Similac® Advance® Early Shield™; 4) Similac® Organic; and 5) Elecare®. Each of the above-listed nutritional powdered beverages was commercially packaged in a container and included a conventional dispensing member. The conventional dispensing members are generally similar in that they each include a generally cylindrical receptacle, a handle extending outward from adjacent an open top of the receptacle, and a hole in the bottom of the receptacle. Some of the conventional dispensing members, however, have different sizes to hold different amounts of the respective powdered beverages. Target amount by mass (g) for each of the conventional dispensing members is provided in the corresponding one of Tables 1-5, each of which is provided below.

[0044] For each of the above-listed nutritional powdered beverages, a total of ten (10) runs were performed. For each run, the nutritional powdered beverage was manually measured from the container using the conventional dispensing member. The conventional dispensing member was manually held by the handle in a substantially vertical orientation, and the nutritional powdered beverage was scooped into the dispensing member. After scooping, the measured nutritional powdered beverage was dispensed from the conventional dispensing member onto a scale to record the amount, by mass, of nutritional powdered beverage that was dispensed. After each run, the dispensed quantity of the nutritional powdered beverage was delivered back into the container of powdered

beverage, and the container was manually shaken. As seen in the below Tables 1-5, the results of the ten (10) runs were used to calculate an average amount of measured and dispensed nutritional powdered beverage, and a standard deviation and a relative standard deviation with respect to the target amount by mass.

[0045] For each of the above-listed nutritional powdered beverages, after completing the ten (10) runs using the provided conventional dispensing member, the dispensing member was modified by drilling seventeen (17) air vents in the sidewall of the dispensing member, and three (3) air vents in the bottom of the dispensing member. Each air vent had a diameter of about 2 mm (0.08 in). For each of the dispensing members, the seventeen (17) air vents in the sidewall and the three (3) air vents in the bottom were arranged substantially as shown in Figs. 6-8.

[0046] For each of the above-listed nutritional powdered beverages, the modified dispensing member was used to perform ten (10) runs. The same procedure that was performed using the provided conventional powdered beverage was performed for each run using the modified dispensing member. The nutritional powdered beverage was manually measured from the container using the modified dispensing member by holding the handle in a substantially vertical orientation and scooping the powdered beverage into the modified dispensing member, and the measured powdered beverage was then dispensed from the modified dispensing member onto a scale to record the amount, by mass, of nutritional powdered beverage that was dispensed. After each run, the dispensed quantity of powdered beverage was delivered back into the container of powdered beverage, and the container was manually shaken. As seen in the below Tables 1-5, the ten (10) results were used to calculate an average amount of measured and dispensed powdered beverage, and a standard deviation and a relative standard deviation with respect to the target amount.

**Table 1:** Similac® Advance® - Dispensed Nutritional Powdered Beverage Using Conventional Dispensing member and Modified Dispensing member

Similac Advance® Target: 8.6 g	Conventional Dispensing member (g)	Modified Dispensing Member (g)
Run 1	8.6	8.4
Run 2	8.8	8.3
Run 3	8.5	8.7
Run 4	8.1	8.5
Run 5	8.5	8.5
Run 6	7.7	8.8
Run 7	8.0	8.7
Run 8	8.7	8.6
Run 9	8.4	8.9
Run 10	9.0	8.8
Average	8.4	8.6
Standard Deviation	0.4	0.2
Relative Standard Deviation	4.6	2.4

[0047] **Table 2:** Similac Sensitive® RS - Dispensed Nutritional Powdered Beverage Using Conventional Dispensing member and Modified Dispensing member

Similac Sensitive® RS Target: 8.7g	Conventional Dispensing Member (g)	Modified Dispensing Member (g)
Run 1	7.09	8.17
Run 2	6.83	8.13
Run 3	7.20	7.77
Run 4	7.16	7.76
Run 5	7.00	7.93
Run 6	7.69	7.87
Run 7	7.61	7.85
Run 8	7.93	8.23
Run 9	7.31	8.13
Run 10	7.65	7.78
Average	7.35	7.96
Standard Deviation	0.34	0.17
Relative Standard Deviation	4.58	2.19

[0048] **Table 3:** Similac® Advance® Early Shield™ - Dispensed Nutritional Powdered Beverage Using Conventional Dispensing member and Modified Dispensing member

Similac® Advance® Early Shield™ Target: 8.7g	Conventional Dispensing Member (g)	Modified Dispensing Member (g)
Run 1	7.57	7.80
Run 2	7.89	8.32
Run 3	8.23	8.15
Run 4	8.27	8.26
Run 5	7.83	7.85
Run 6	8.46	7.59
Run 7	7.35	8.38
Run 8	8.51	7.82
Run 9	8.01	7.72
Run 10	7.91	8.36
Average	8.00	8.03
Standard Deviation	0.37	0.30
Relative Standard Deviation	4.66	3.72

[0049] **Table 4:** Similac® Organic - Dispensed Nutritional Powdered Beverage Using Conventional Dispensing Member and Modified Dispensing Member

Similac® Organic Target: 8.6g	Conventional Dispensing Member (g)	Modified Dispensing Member (g)
Run 1	6.47	8.24
Run 2	6.90	8.25
Run 3	7.00	7.20
Run 4	8.57	8.32
Run 5	7.45	8.19
Run 6	7.73	7.92
Run 7	7.70	8.18
Run 8	8.40	8.26
Run 9	8.30	7.83
Run 10	8.13	8.20
Average	7.67	8.06
Standard Deviation	0.71	0.34
Relative Standard Deviation	9.21	4.22

[0050] **Table 5:** Elecare® - Dispensed Nutritional Powdered Beverage Using Conventional Dispensing Member and Modified Dispensing Member

Elecare® Target: 9.4g	Conventional Dispensing Member (g)	Modified Dispensing Member (g)
Run 1	8.08	8.57
Run 2	8.49	9.86
Run 3	8.31	8.88
Run 4	9.19	8.95
Run 5	8.93	9.06
Run 6	8.77	9.68
Run 7	8.49	9.39
Run 8	8.45	8.93
Run 9	9.27	9.38
Run 10	9.63	9.09
Average	8.76	9.18
Standard Deviation	0.49	0.39
Relative Standard Deviation	5.56	4.29

[0051] As can be seen from the above Tables 1-5, each of the modified dispensing members had an average amount, by mass, of dispensed nutritional powdered beverage that was closer to the corresponding target amount than the corresponding conventional dispensing member. Moreover, each of the modified dispensing members had a standard deviation and a relative standard deviation that were less than the respective standard deviation and relative standard deviation of the corresponding conventional dispensing member. Accordingly, one can reasonable conclude that the modified dispensing members dispensed nutritional powdered beverage more accurately than the respective conventional dispensing members.

[0052] When introducing elements of the present invention or preferred embodiments thereof, the articles "a", "an", "the", and "said" are intended to mean that there are one or more of the elements. The terms "comprising", "including", and "having" are intended to be inclusive and mean that there may be additional elements other than the listed elements.

[0053] As various changes could be made in the above constructions and methods without departing from the scope of the invention, it is intended that all matter contained in the above description and shown in the accompanying drawings shall be interpreted as illustrative and not in a limiting sense.

## WHAT IS CLAIMED IS:

1. A package of powdered beverage product comprising:

a container having an interior space;

a quantity of nutritional powdered beverage in the interior space of the container;

and

5 a dispensing member for dispensing a quantity of the powdered nutritional beverage from the interior space of the container, the dispensing member including

10 a receptacle for holding the quantity of the powdered nutritional beverage, the receptacle having an open top, a bottom, and a sidewall extending therebetween such that the open top, the bottom and the sidewall together define an interior space for holding the powdered nutritional beverage in the receptacle, the receptacle having an imaginary axis lengthwise along the sidewall from the bottom to the top of the receptacle,

15 a handle attached to and extending at least in part transversely outward from the receptacle, the handle having an imaginary longitudinal axis, the imaginary axis of the receptacle intersecting the imaginary axis of the handle at a handle-intersecting location, the receptacle sidewall having an air-venting portion extending circumferentially up to and including about 45 degrees about the receptacle from the imaginary axis thereof, and

20 at least one air vent extending through the sidewall of the receptacle to the interior space of the receptacle, the at least one air vent being disposed entirely within the air-venting portion of the sidewall.

2. The package set forth in claim 1 wherein the sidewall of the receptacle is substantially free from air vents disposed other than within the air-venting portion of the sidewall.

3. The package set forth in claim 1 wherein the at least one air vent comprises a plurality of air vents, said plurality of air vents being disposed within the air-venting portion of the sidewall.

4. The package set forth in claim 2 wherein the plurality of air vents are arranged in a generally triangular pattern.

5. The package set forth in claim 4 wherein the handle-intersecting location is generally adjacent to the open top of the receptacle, and wherein the plurality of air vents are disposed intermediate the handle-intersecting location and the bottom of the receptacle.

6. The package set forth in claim 1 wherein the at least one air vent comprises a slot-shaped air vent having a length extending generally lengthwise of the receptacle sidewall.

7. The package set forth in claim 6 wherein the length of the slot-shaped air vent extends from generally adjacent to the handle-intersecting location to the bottom of the receptacle.

8. The package set forth in claim 6 wherein the slot-shaped air vent further extends through the bottom of the receptacle.

9. The package set forth in claim 6 wherein the nutritional powdered beverage comprises a high fat powdered beverage.

10. The package set forth in claim 6 wherein the slot-shaped air vent has a width in the range of about 1 mm (0.04 in) to about 5 mm (0.20 in).

11. The package set forth in claim 6 wherein the slot-shaped air vent has a terminal upper end at a location intermediate the top and the bottom of the receptacle sidewall and corresponding to a predetermined quantity of nutritional powdered beverage when the receptacle is filled to the terminal upper end of the air vent.

12. A dispensing member for use in dispensing a quantity of powdered beverage product, the dispensing member comprising:

a receptacle for holding a quantity of the powdered beverage, the receptacle having an open top, a bottom, and a sidewall extending therebetween such that the open top, the bottom and the sidewall together define an interior space for holding the powdered beverage in the receptacle, the receptacle having an imaginary axis lengthwise along the sidewall from the bottom to the top of the receptacle;

10 a handle attached to and extending at least in part transversely outward from the receptacle, the handle having an imaginary longitudinal axis, the imaginary axis of the receptacle intersecting the imaginary axis of the handle at a handle-intersecting location, the receptacle sidewall having an air-venting portion extending circumferentially up to and including about 45 degrees about the receptacle from the imaginary axis thereof; and

15 at least one air vent extending through the sidewall of the receptacle to the interior space of the receptacle, the at least one air vent being disposed entirely within the air-venting portion of the sidewall.

13. A dispensing member for use in dispensing a quantity of powdered beverage product, the dispensing member comprising:

5 a receptacle for holding a quantity of the powdered beverage, the receptacle having an open top, a bottom, and a sidewall extending therebetween such that the open top, the bottom and the sidewall together define an interior space for holding the powdered beverage in the receptacle, the sidewall of the receptacle having an elongate slot disposed therein; and

a handle attached to and extending transversely outward from the receptacle.

14. A dispensing member for use in dispensing a quantity of powdered beverage product, the dispensing member comprising:

5 a receptacle for holding a quantity of the powdered beverage, the receptacle having an open top, a bottom, and a sidewall extending therebetween such that the open top, the bottom and the sidewall together define an interior space for holding the powdered beverage in the receptacle; and

a handle attached to and extending transversely outward from the receptacle,

10 the sidewall of the receptacle having a plurality of openings therein in spaced relationship with each other, at least one half of the plurality of openings being disposed in the sidewall circumferentially within 45 degrees of a line extending longitudinally along the sidewall and intersecting the handle.

15. A dispensing member for use in dispensing a quantity of powdered beverage product, the dispensing member comprising:

a receptacle for holding a quantity of the powdered beverage, the receptacle having an open top, a bottom, and a sidewall extending therebetween such that the open top, the bottom and the sidewall together define an interior space for holding the powdered beverage in the receptacle; and

a handle attached to and extending transversely outward from the receptacle,

the sidewall of the receptacle having at least one air vent disposed in the sidewall of the receptacle, the air vent being sized and located on said sidewall such that the air vent corresponds to a predetermined quantity of powdered beverage that is less than a full capacity of the receptacle.

1/8

FIG. 1

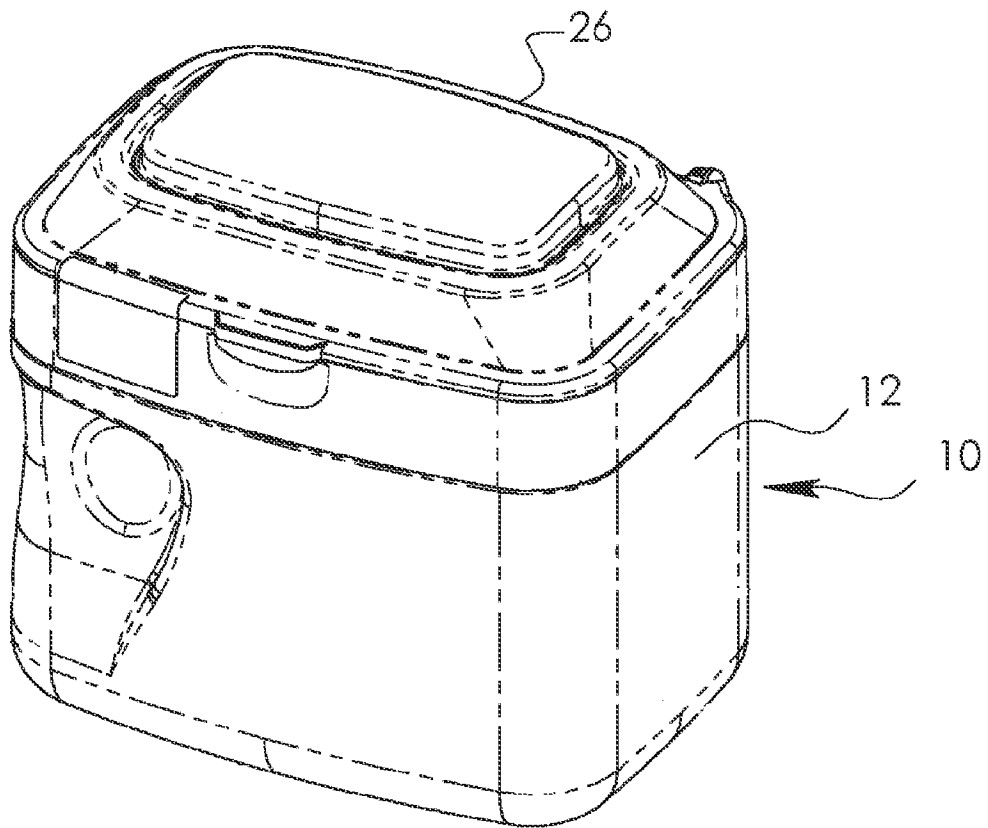

FIG. 2

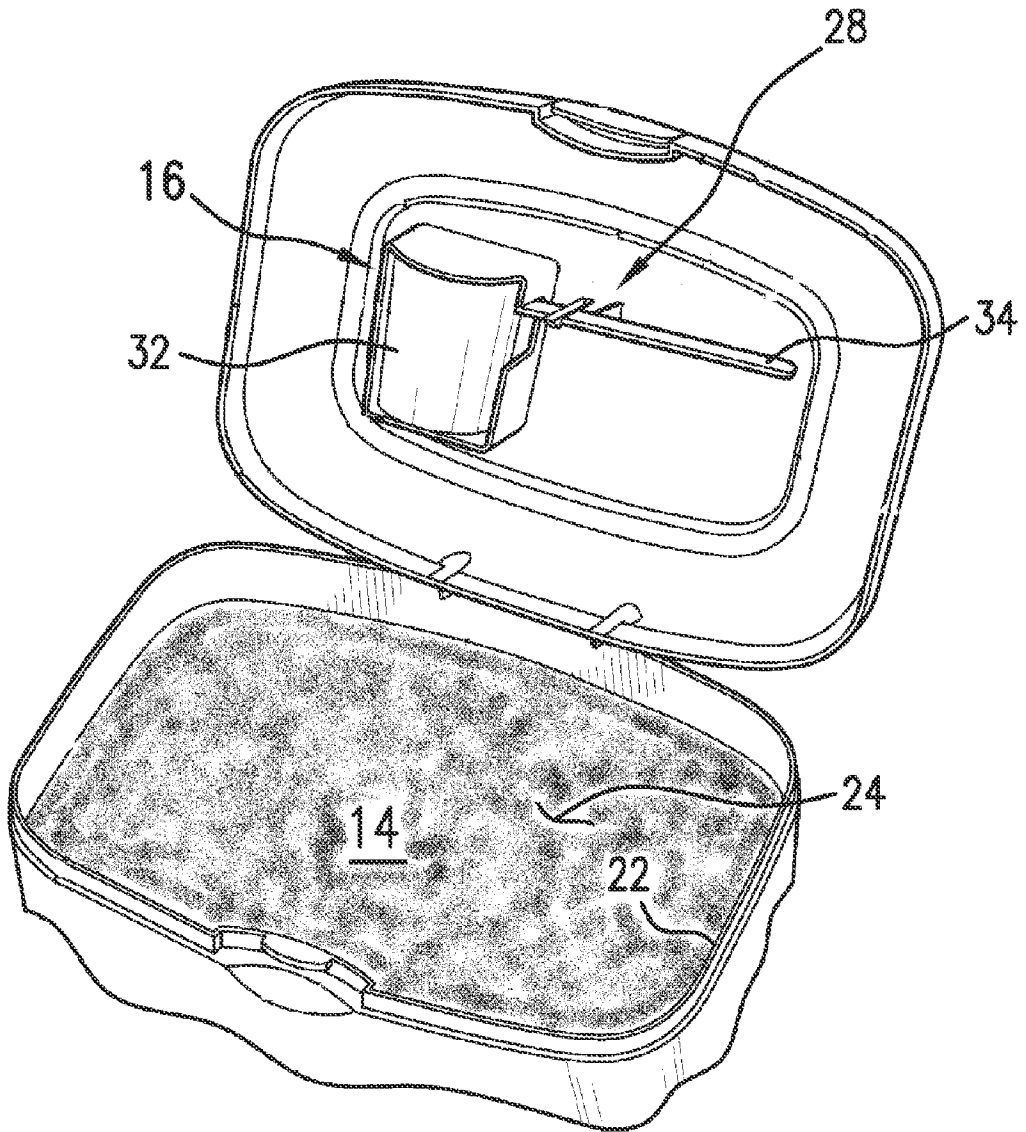
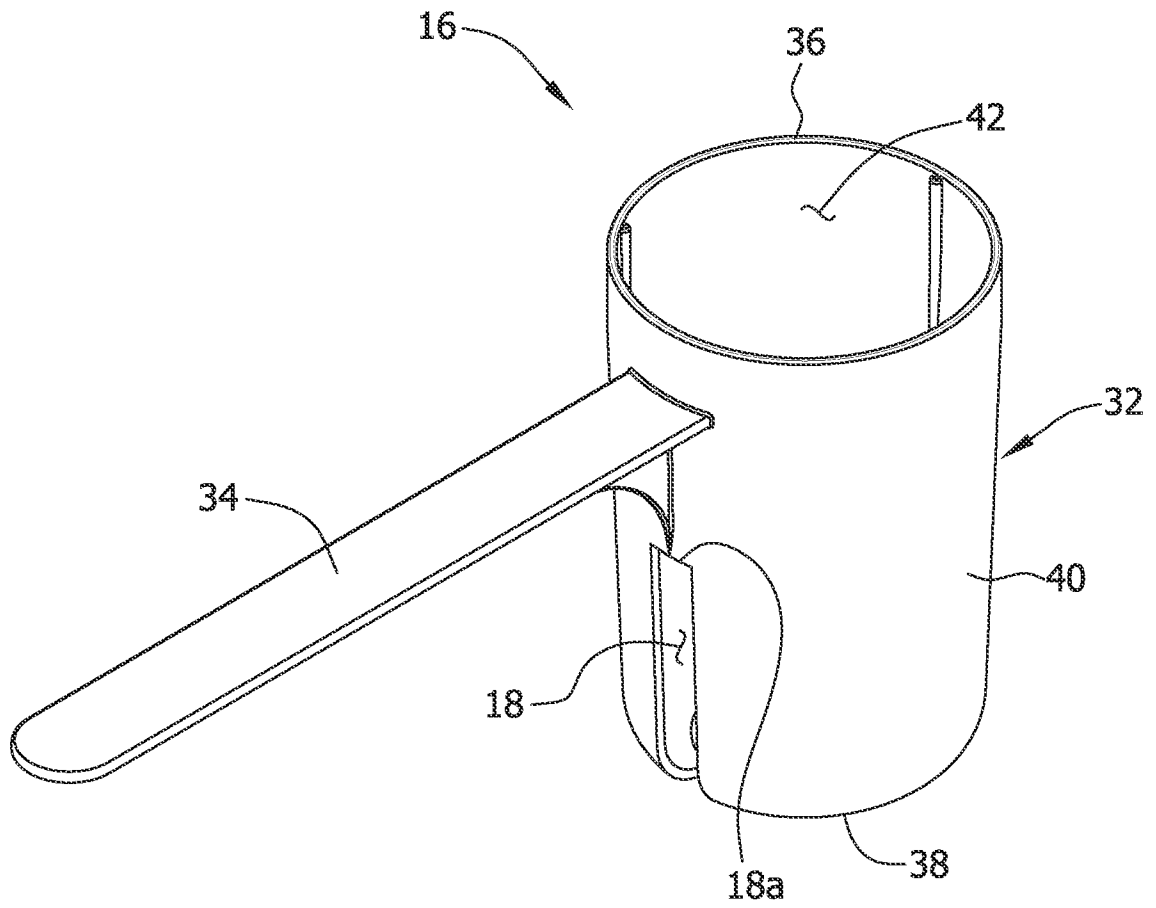

FIG. 3



4/8

FIG. 4

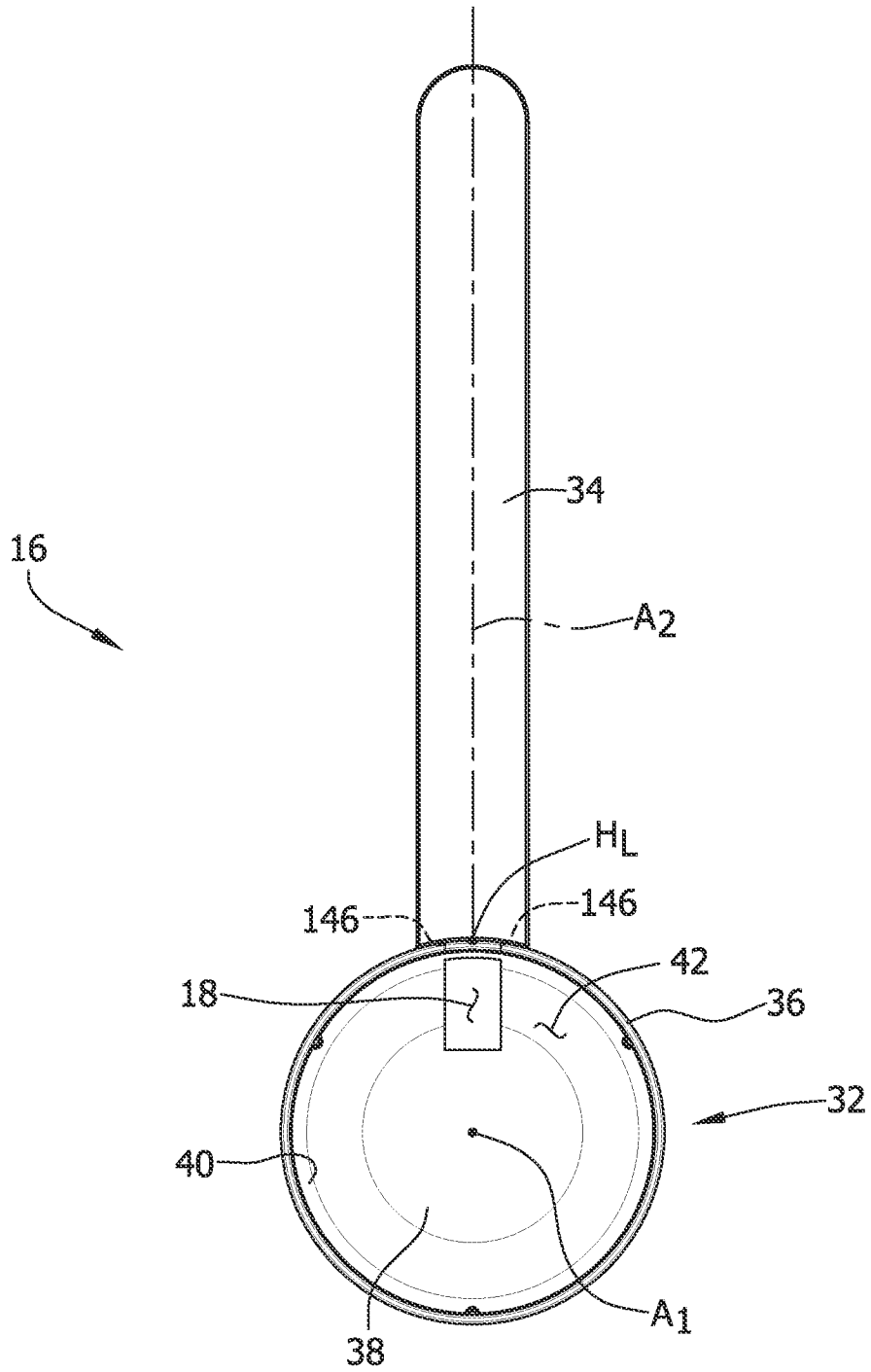

FIG. 5

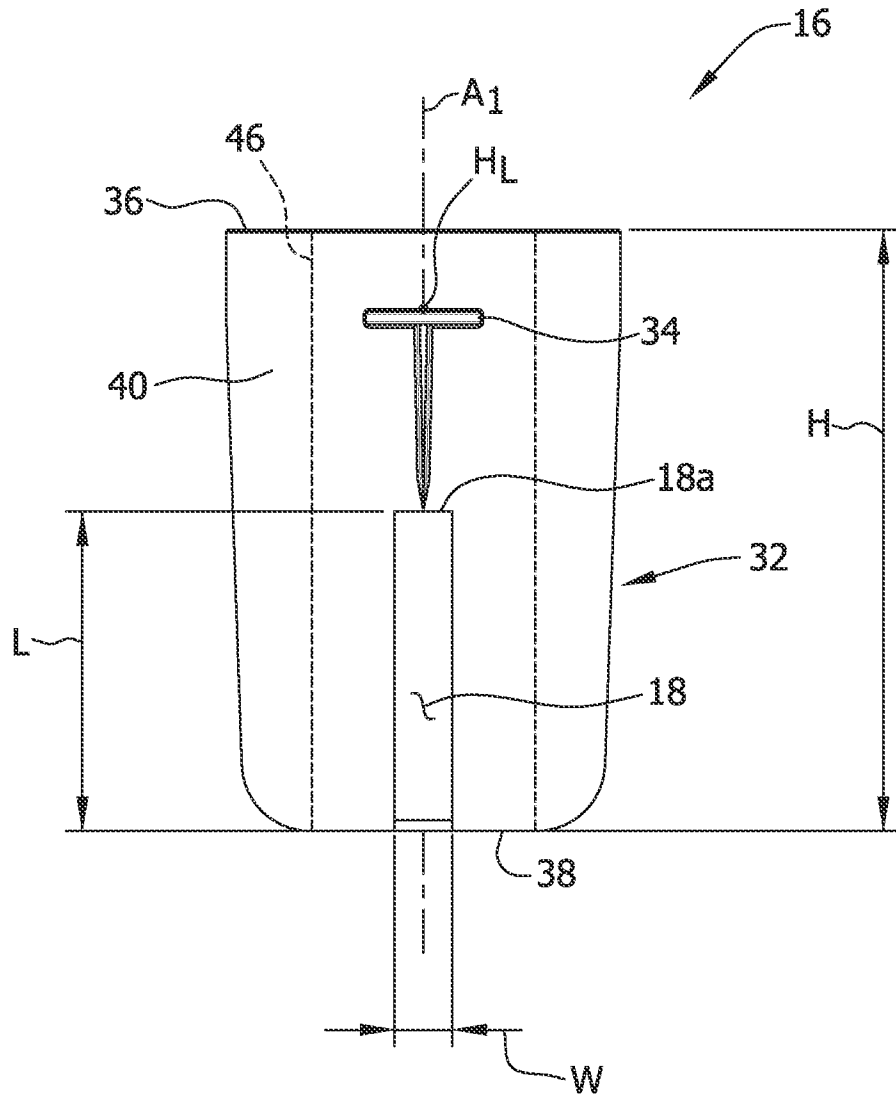
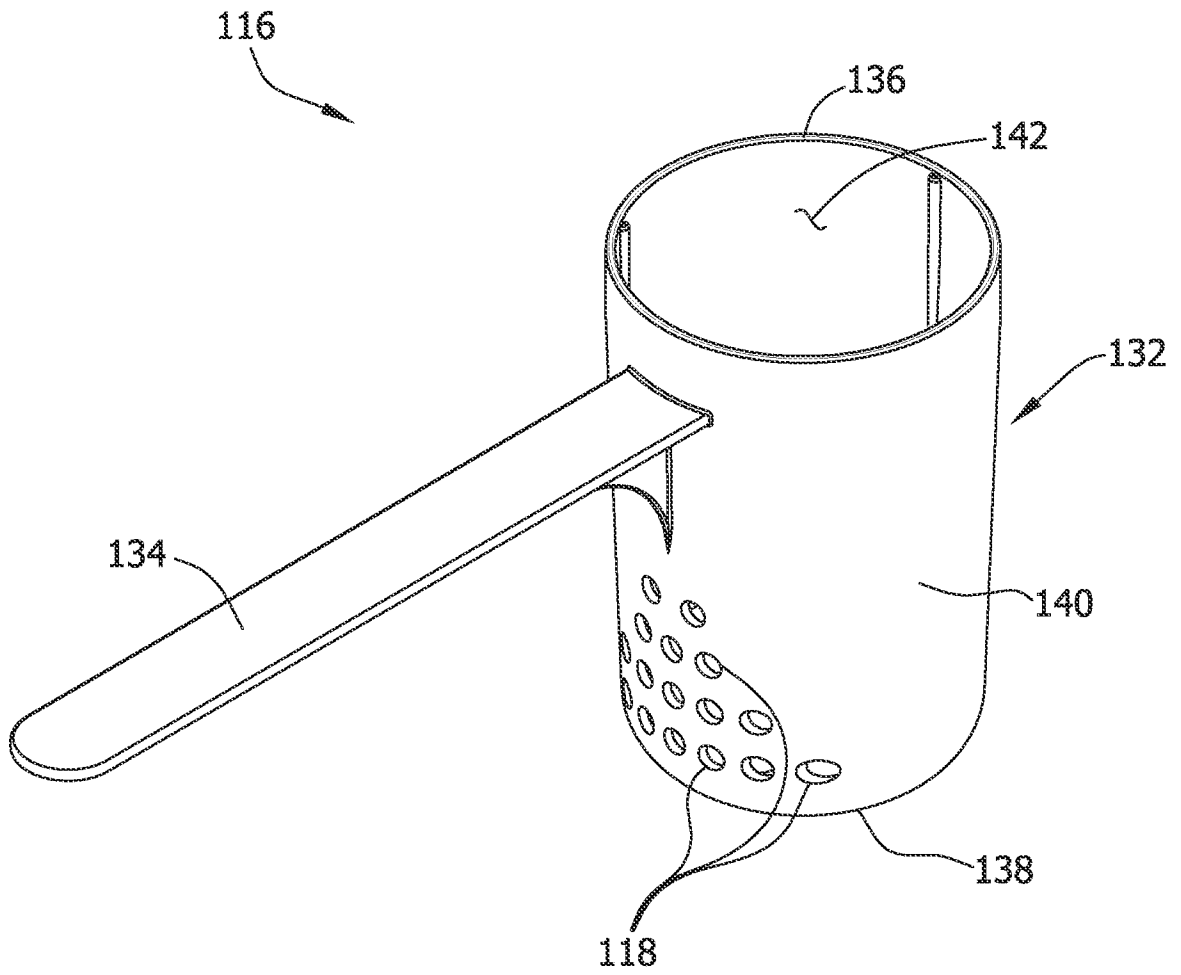

FIG. 6



7/8

FIG. 7

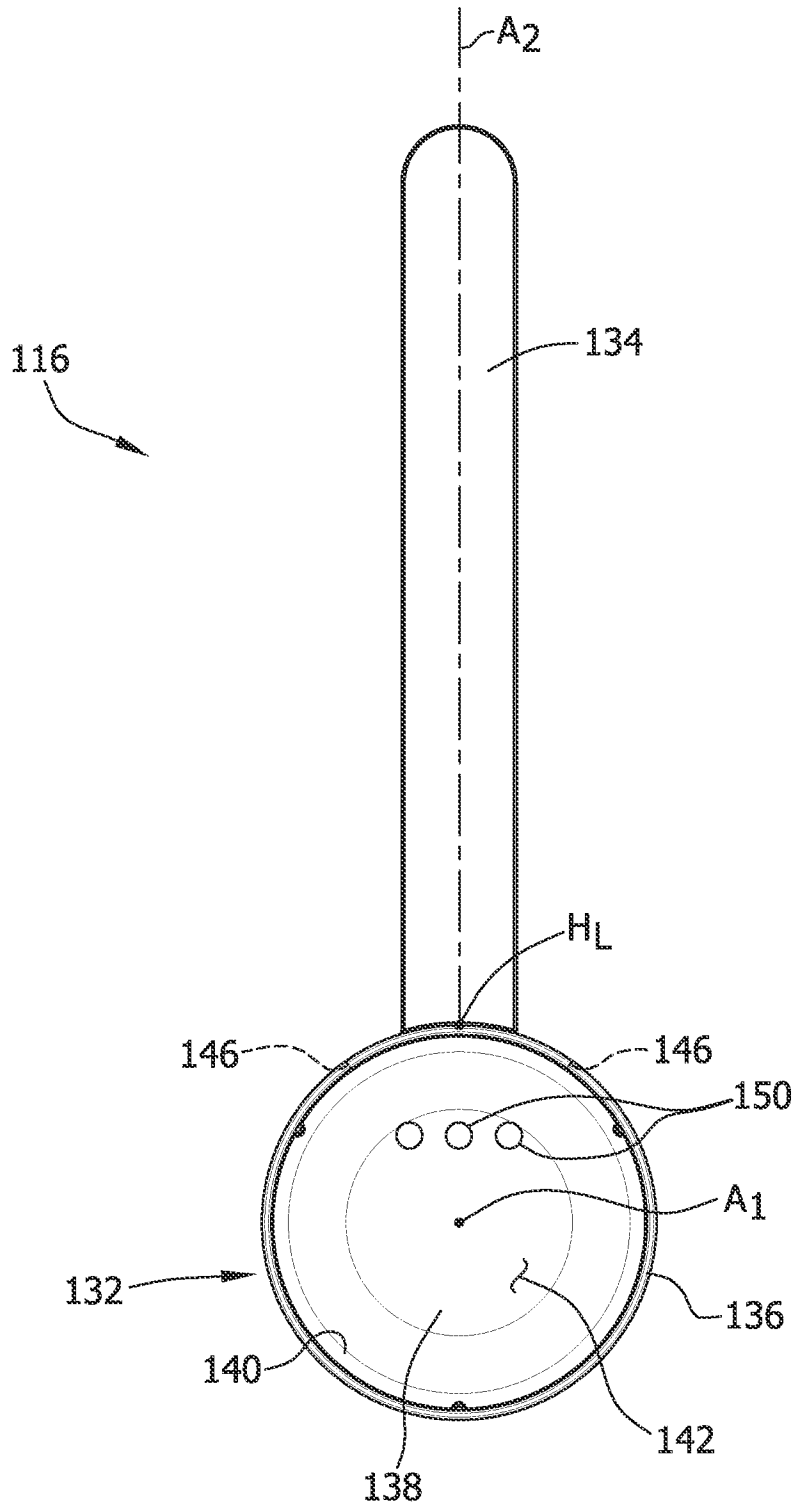
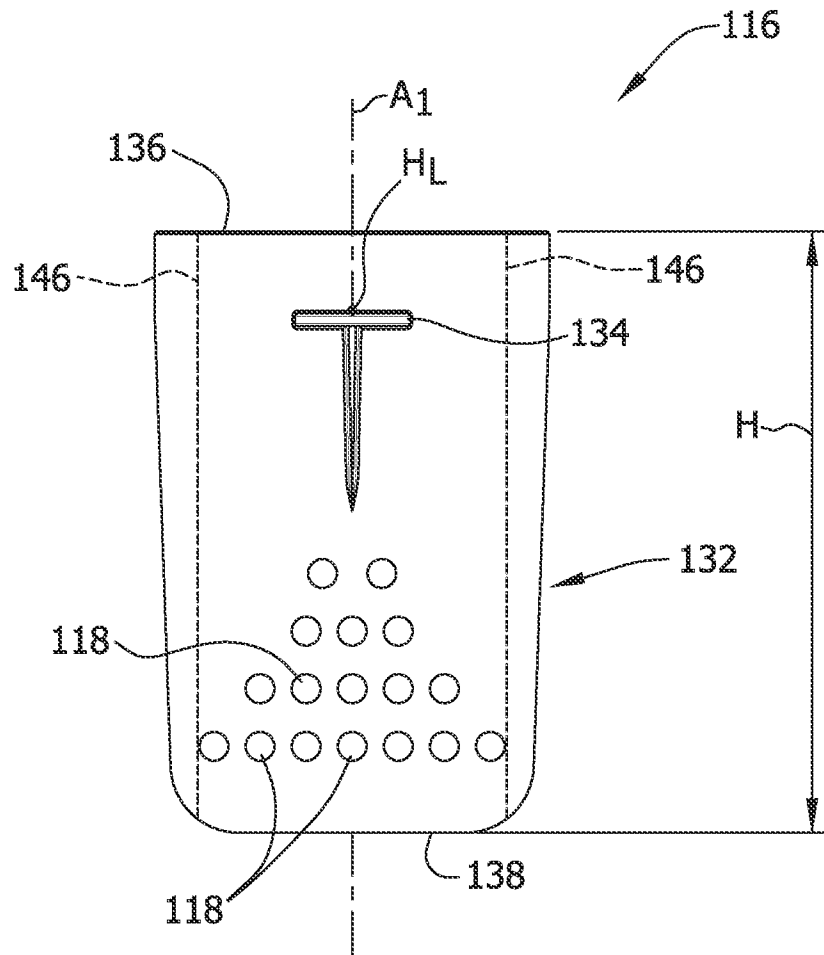

FIG. 8



INTERNATIONAL SEARCH REPORT

International application No  
PCT/US2011/064236

A. CLASSIFICATION OF SUBJECT MATTER  
INV. A47J43/28 G01F19/00  
ADD.  
According to International Patent Classification (IPC) or to both national classification and IPC

B. FIELDS SEARCHED  
Minimum documentation searched (classification system followed by classification symbols)  
A47J G01F  
Documentation searched other than minimum documentation to the extent that such documents are included in the fields searched

Electronic data base consulted during the international search (name of data base and, where practical, search terms used)  
EPO-Internal, PAJ, WPI Data

C. DOCUMENTS CONSIDERED TO BE RELEVANT		
Category*	Citation of document, with indication, where appropriate, of the relevant passages	Relevant to claim No.
X	US 2 570 521 A (CHESTER FRANK R) 9 October 1951 (1951-10-09) column 1, line 54 - column 3, line 30; figures -----	1,3,5,8, 9,12,15
X	DE 20 2007 017058 U1 (MELITTA HAUSHALTSPRODUKTE [DE]) 6 March 2008 (2008-03-06) paragraphs [0019] - [0025]; figures -----	1,2,6,9, 10,12-15
X	WO 2004/042331 A1 (MURPHY NEIL [GB]; MURPHY CHRISTINE ANNE [GB]) 21 May 2004 (2004-05-21) page 4, line 22 - page 8, line 7; figures -----	13
A	US 2009/261113 A1 (MIOTA NICHOLAS J [US] ET AL) 22 October 2009 (2009-10-22) paragraphs [0018] - [0025]; figures ----- -/--	1-15

Further documents are listed in the continuation of Box C.

See patent family annex.

\* Special categories of cited documents :

<p>"A" document defining the general state of the art which is not considered to be of particular relevance</p> <p>"E" earlier document but published on or after the international filing date</p> <p>"L" document which may throw doubts on priority claim(s) or which is cited to establish the publication date of another citation or other special reason (as specified)</p> <p>"O" document referring to an oral disclosure, use, exhibition or other means</p> <p>"P" document published prior to the international filing date but later than the priority date claimed</p>	<p>"T" later document published after the international filing date or priority date and not in conflict with the application but cited to understand the principle or theory underlying the invention</p> <p>"X" document of particular relevance; the claimed invention cannot be considered novel or cannot be considered to involve an inventive step when the document is taken alone</p> <p>"Y" document of particular relevance; the claimed invention cannot be considered to involve an inventive step when the document is combined with one or more other such documents, such combination being obvious to a person skilled in the art.</p> <p>"&amp;" document member of the same patent family</p>
--	--

Date of the actual completion of the international search  2 March 2012	Date of mailing of the international search report  09/03/2012
---	--

Name and mailing address of the ISA/ European Patent Office, P.B. 5818 Patentlaan 2 NL - 2280 HV Rijswijk Tel. (+31-70) 340-2040, Fax: (+31-70) 340-3016	Authorized officer  De Terlizzi, Marino
--	---

# INTERNATIONAL SEARCH REPORT

International application No  
PCT/US2011/064236

C(Continuation). DOCUMENTS CONSIDERED TO BE RELEVANT		
Category*	Citation of document, with indication, where appropriate, of the relevant passages	Relevant to claim No.
A	DE 201 01 563 U1 (WANG JEN CHIEN [TW]) 12 April 2001 (2001-04-12) page 3, line 16 - page 6, line 2; figures -----	1-15

# INTERNATIONAL SEARCH REPORT

Information on patent family members

International application No PCT/US2011/064236
---

Patent document cited in search report	Publication date	Patent family member(s)	Publication date
US 2570521	A	09-10-1951	NONE
-----			
DE 202007017058	U1	06-03-2008	DE 202007017058 U1
			EP 2068132 A1
			06-03-2008
			10-06-2009
-----			
WO 2004042331	A1	21-05-2004	AU 2003278430 A1
			GB 2411391 A
			07-06-2004
			31-08-2005
			WO 2004042331 A1
			21-05-2004
-----			
US 2009261113	A1	22-10-2009	NONE
-----			
DE 20101563	U1	12-04-2001	DE 20101563 U1
			FR 2820022 A3
			02-08-2002
			GB 2371469 A
			31-07-2002
-----			