

C. M. GATES.
 ANTIRAIL SPREADING DEVICE.
 APPLICATION FILED MAR. 21, 1911.

1,002,668.

Patented Sept. 5, 1911.

Fig. 1.

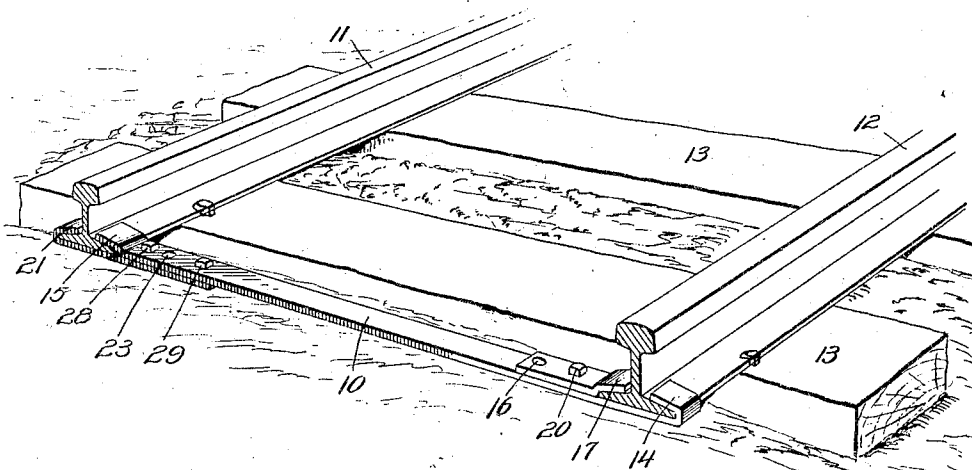

Fig. 2.

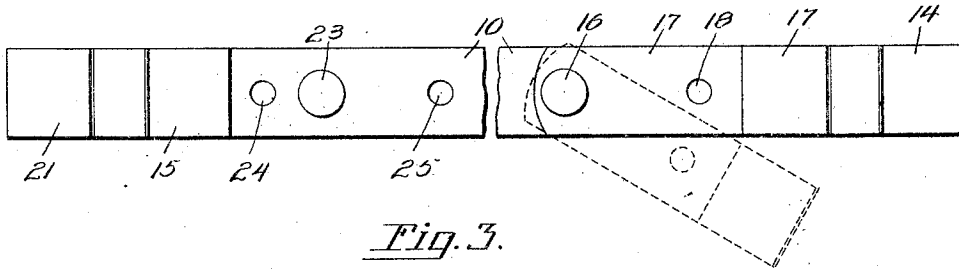

Fig. 3.

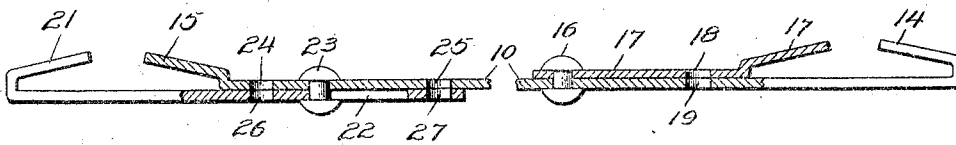
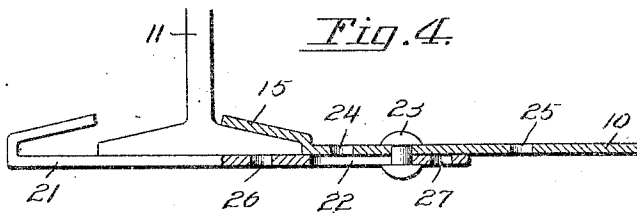

Fig. 4.



Inventor
 Charles M. Gates.

Witnesses
 F. L. Gibson.
 P. A. Hoster

By Victor J. Evans
 Attorney

UNITED STATES PATENT OFFICE.

CHARLES M. GATES, OF GARY, WEST VIRGINIA.

ANTI-RAIL-SPREADING DEVICE.

1,002,668.

Specification of Letters Patent.

Patented Sept. 5, 1911.

Application filed March 21, 1911. Serial No. 615,834.

To all whom it may concern:

Be it known that I, CHARLES M. GATES, a citizen of the United States, residing at Gary, in the county of McDowell and State of West Virginia, have invented new and useful Improvements in Anti-Rail-Spreading Devices, of which the following is a specification.

An object of the invention is to provide an anti-rail spreading device for attachment to the rails between the ties thereof to prevent any spreading of the rails.

Among other features, my invention embodies a bar having an end thereof formed into a hook for engagement with the outer side of a rail, a gripping lug pivotally mounted on the said bar and adapted to engage the inner side of the said rail, an integral gripping lug formed on the other end of the said bar for engagement with the inner side of an opposite rail and an adjusting hook mounted to slide and to turn on the bar adjacent the said integral gripping lug, the said adjusting hook being adapted for engagement with the outer side of the said opposite rail so that my device can be properly adjusted relatively to the said rail, the said adjusting hook being then rigidly secured to the said bar to properly position my device so that it will perform the desired function.

Reference is to be had to the accompanying drawings constituting a part of this specification, in which similar characters of reference denote corresponding parts in all the views, and in which—

Figure 1 is a perspective view of a pair of rails mounted on ties in the usual manner and having my device applied thereto. Fig. 2 is a plan view, parts being broken away and the gripping lug being shown in dotted lines in open or disengaging position. Fig. 3 is a fragmentary longitudinal sectional view, and Fig. 4 is a fragmentary vertical section of one end of my device showing the same applied to a rail and with the adjusting hook in initial position relatively to the rail.

Referring more particularly to the views, I employ a bar 10 for disposal between rails 11, 12 secured to the ties 13 in the usual manner. The bar 10 is provided at one end with an integral hook 14 for engagement with the outer side of the rail 12 and the said bar is provided at the other end with an integral gripping lug 15 for engagement

with the inner side of the rail 11. Mounted to swing on a lug 16 formed on the bar 10 is a gripping lug 17, the said gripping lug being adapted to engage the inner side of the rail 12 as shown in Fig. 1, and the said gripping lug being provided with an aperture 18 adapted to align with an aperture 19 in the bar 10 so that a bolt 20 can be passed through the apertures 18 and 19 to secure the gripping lug 17 in rigid position. Mounted to swing on the other end of the bar 10 is an adjusting hook 21, the said hook being provided with a slot 22 in which is received a rivet 23 engaging the bar 10 so that the hook 21 can be turned and slid longitudinally relatively to the bar 10. Apertures 24, 25 are formed in the bar 10 and apertures 26, 27 are formed in the adjusting hook 21, the apertures 24 and 26 and the apertures 25 and 27 respectively, being adapted to register so that bolts 28, 29 can be passed therethrough to rigidly secure the adjusting hook 21 to the bar 10.

In the application of my device to the rails 11, 12, the bar 10 is so disposed that the hook 14 will engage the outer side of the rail 12. The gripping lug 17 is then pivoted on the bar 10 to engage the inner side of the rail 12 and the said gripping lug is then rigidly secured to the bar 10 by passing through the apertures 18, 19 and the bolt 20. It will be readily seen that when the hook 14 of the bar 10 engages the outer side of the rail 12, the integral gripping lug 15 at the other end of the bar 10 will engage the inner side of the rail 11 as shown in Fig. 1. The adjusting hook 21 is now slid outwardly and swung relatively to the bar 10 to engage the outer side of the rail 11 and when the said adjusting hook has been positioned as desired, the relative apertures 24 and 26 and 25 and 27 will register so that the bolts 28, 29 can be passed therethrough to rigidly secure the adjusting hook 21 to the bar 10, thus providing a rigid connection between the rails 11 and 12 and preventing any spreading thereof.

Having thus fully described the invention, what I claim as new, is:—

1. A device of the class described comprising a bar, a hook integrally formed on one end of the said bar and adapted for engagement with the outer side of the other rail, a gripping lug integrally formed on the other end of the said bar and adapted

for engagement with the inner side of an opposite rail, a second gripping lug mounted to swing on the said bar and adapted to engage the inner side of the first mentioned rail, the said gripping lug being adapted to be rigidly secured to the said bar, and an adjusting hook mounted to slide and to turn on the said bar adjacent the said integral gripping lug, the said adjusting hook being adapted to engage the outer side of the second mentioned rail and adapted to be rigidly secured to the said bar.

2. A device of the class described comprising a bar having one end thereof for engagement with the outer side of a rail and the other end thereof for engagement with the inner side of an opposing rail, means mounted at one end of the said bar for engagement with the inner side of the first mentioned rail and adapted to be secured to the said bar, and means mounted to slide and to turn on the other end of the said bar and adapted for engagement with the outer side of the second mentioned rail, the said means being adapted to be rigidly secured to the said bar.

3. A device of the class described comprising a bar having one end thereof for engagement with the outer side of a rail and the other end thereof for engagement with the inner side of an opposing rail, means mounted to turn on the said bar and adapted to engage the inner side of the first mentioned rail, the said means being adapted to be rigidly secured to the said bar and

an adjusting hook mounted to turn and to slide on the said bar and adapted to engage the outer side of the second mentioned rail, the said adjusting hook being adapted to be rigidly secured to the said bar.

4. A device of the class described comprising a bar having one end thereof adapted for engagement with the outer side of a rail and the other end thereof adapted for engagement with the inner side of an opposing rail, gripping means pivotally mounted on the said bar and adapted to engage the inner side of the first mentioned rail and an adjusting hook mounted to turn and to slide on the said bar and adapted to engage the outer side of the second mentioned rail, the said adjusting hook being adapted to be rigidly secured to the said bar.

5. In a device of the class described the combination of a bar having one end thereof for engagement with the outer side of a rail and the other end thereof for engagement with the inner side of an opposing rail, means mounted at one end of the said bar for engagement with the inner side of the first mentioned rail and means mounted to turn and to slide on the other end of the said bar and adapted for engagement with the outer side of the second mentioned rail.

In testimony whereof I affix my signature in presence of two witnesses:

CHARLES M. GATES.

Witnesses:

THOS. MCPARLAND,
WILLIS W. HARDING.