

No. 719,009.

PATENTED JAN. 27, 1903.

D. W. JONES.  
SELF DUMPING COAL ELEVATOR.

APPLICATION FILED OCT. 16, 1902.

NO MODEL.

3 SHEETS—SHEET 1.

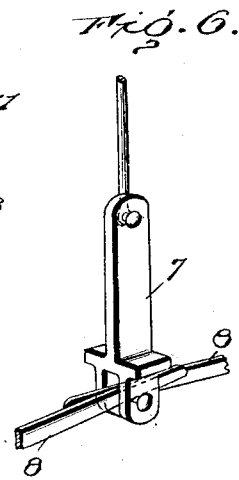
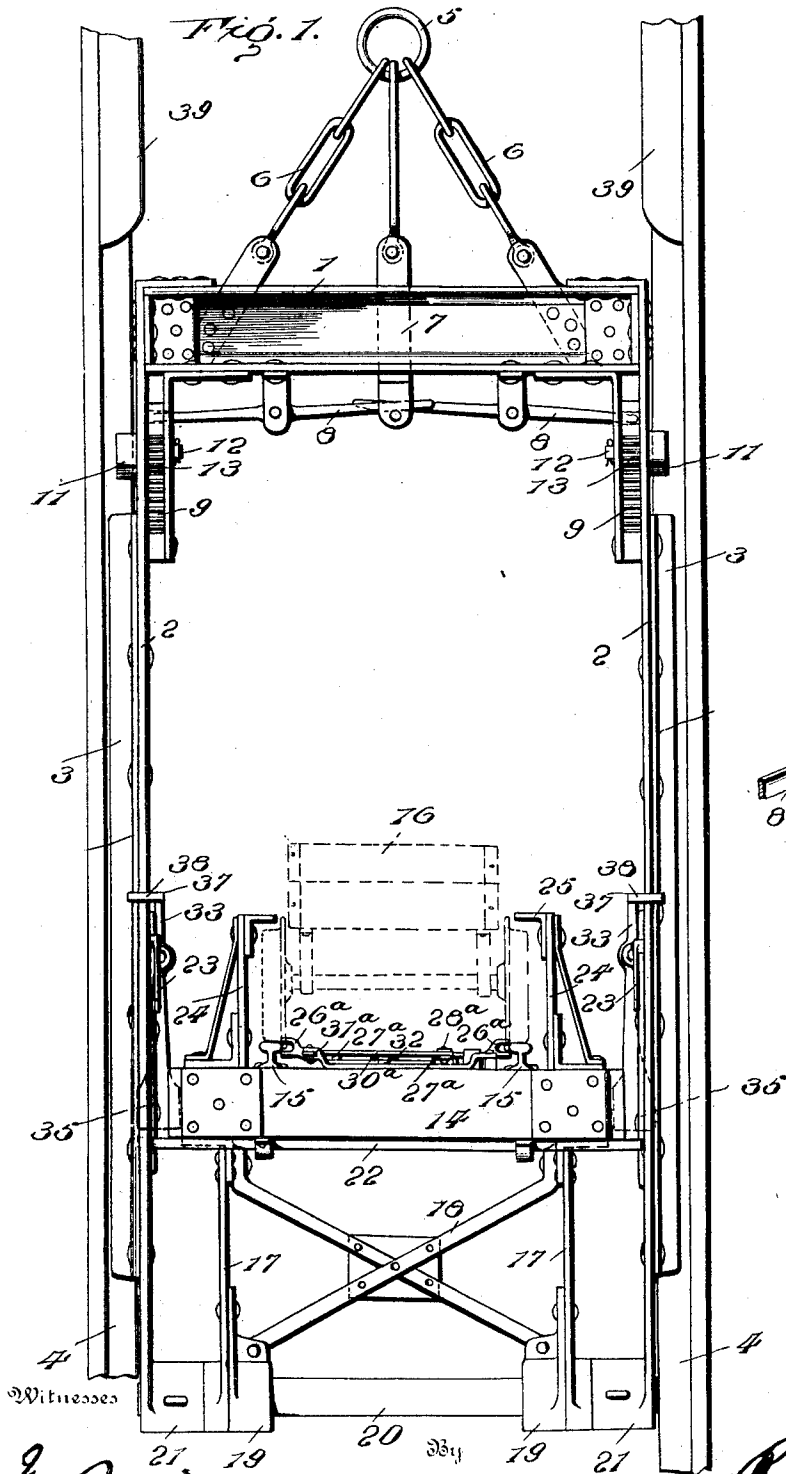

Witnesses  
*Jas. M. ...*  
*Gladys Thompson*

Inventor  
 D. W. Jones.

*R. H. ...*  
 Attorney,  
 702 S. ...

No. 719,009.

PATENTED JAN. 27, 1903.

D. W. JONES.  
SELF DUMPING COAL ELEVATOR.

APPLICATION FILED OCT. 16, 1902.

NO MODEL.

3 SHEETS—SHEET 2.

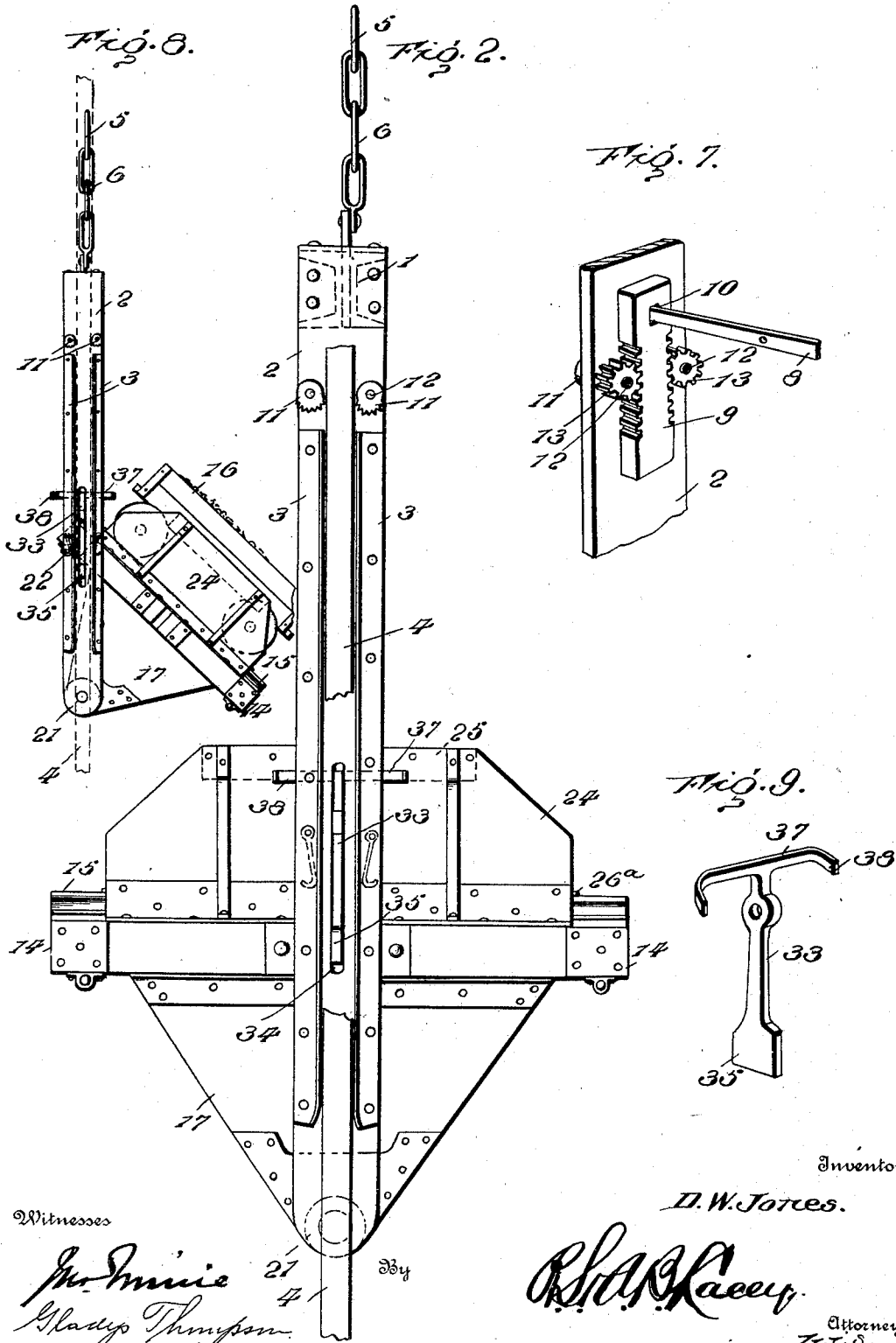

Witnesses

*Johnnie* 27  
*Gladys Thompson* 4

Inventor

*D. W. Jones.*

*R. A. Racy*

Attorney  
700 S.

No. 719,009.

PATENTED JAN. 27, 1903.

D. W. JONES.  
SELF DUMPING COAL ELEVATOR.

APPLICATION FILED OCT. 16, 1902.

NO MODEL.

3 SHEETS—SHEET 3.

FIG. 3.

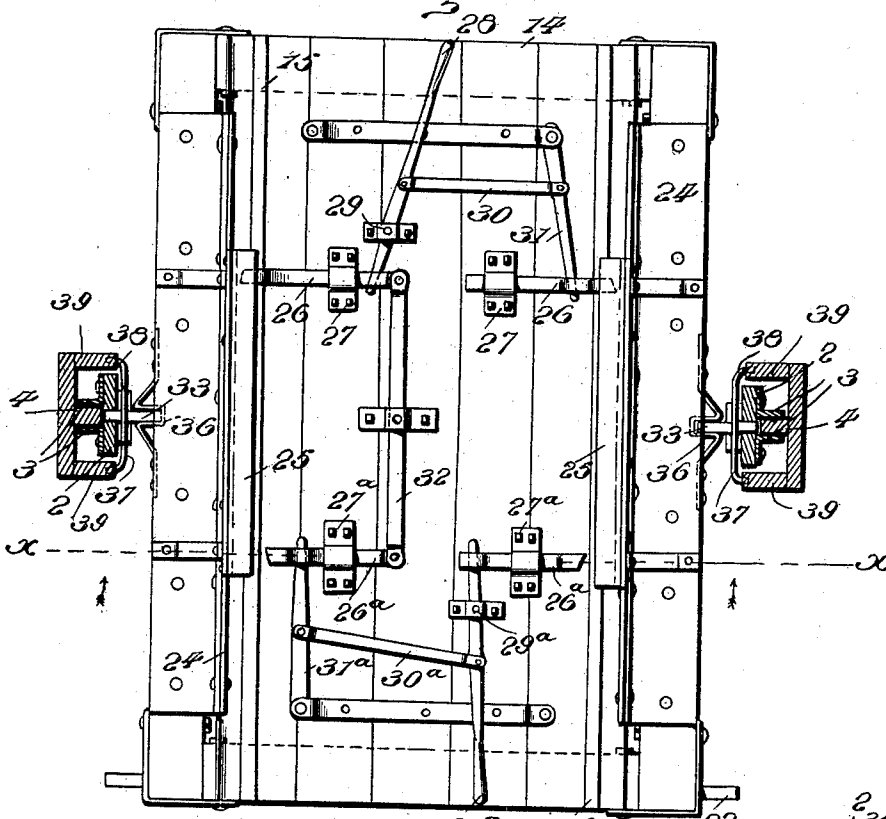

FIG. 4.

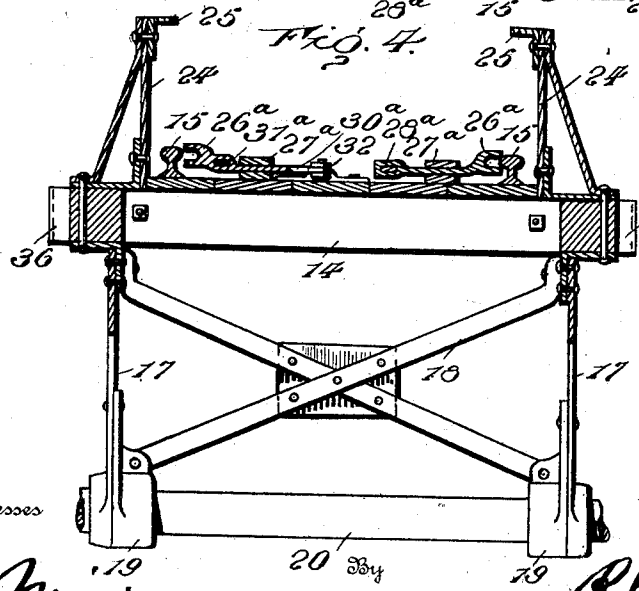
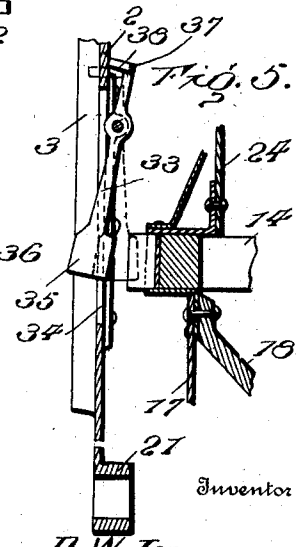

FIG. 5.



Witnesses

*John M. ...*  
*Gladys Thompson.*

Inventor

D. W. Jones.

*R. H. Racy,*  
Attorneys  
P.C.S.

# UNITED STATES PATENT OFFICE.

DAVID W. JONES, OF LUHRIG, OHIO.

## SELF-DUMPING COAL-ELEVATOR.

SPECIFICATION forming part of Letters Patent No. 719,009, dated January 27, 1903.

Application filed October 16, 1902. Serial No. 127,558. (No model.)

*To all whom it may concern:*

Be it known that I, DAVID W. JONES, a citizen of the United States, residing at Luhrig, in the county of Athens and State of Ohio, have invented certain new and useful Improvements in Self-Dumping Coal-Elevators, of which the following is a specification.

This invention relates to hoisting mechanism for mining operations, being particularly adapted for use in coal-mines for automatically dumping the load when it reaches the predetermined elevation above the shaft.

The invention contemplates novel means for securing the car upon the platform, said means being operable from either end of the platform either to obstruct the passage of the car or clear the way therefor.

The invention is applicable to elevating mechanism of any class and is not restricted to the type of hoisting mechanism shown.

For a full description of the invention and the merits thereof and also to acquire a knowledge of the details of construction of the means for effecting the result reference is to be had to the following description and drawings hereto attached.

While the essential and characteristic features of the invention are susceptible of modification, still the preferred embodiment of the invention is illustrated in the accompanying drawings, in which—

Figure 1 is a front view of an elevator embodying the vital features of the invention. Fig. 2 is a side view thereof. Fig. 3 is a top plan view of the platform, showing the suspending-frame in horizontal section. Fig. 4 is a section on the line XX of Fig. 3 looking in the direction of the arrows. Fig. 5 is a detail view showing the operation of the catch for holding the platform in a normal position by full and dotted lines. Fig. 6 is a detail view in perspective of the clevis and the overlapped end portions of the safety-levers. Fig. 7 is a detail perspective view of the safety mechanism. Fig. 8 is a view similar to Fig. 2 on a smaller scale, showing the position of the platform when tilted to dump the load. Fig. 9 is a detail perspective view of a catch for holding the platform in a horizontal position. Corresponding and like parts are referred to in the following description and indicated

in all the views of the drawings by the same reference characters.

The suspending-frame comprises a cross-piece 1 and uprights 2, the parts being rigidly connected at their meeting ends. Spaced guides 3 are secured to the uprights 2 and are adapted to embrace opposite sides of the guide-posts 4, arranged at the sides of the shaft or well in which the platform or car operates. The hoisting rope or cable (not shown) is adapted to be connected to the ring 5, to which draft-chains 6 are likewise attached and are connected at their lower ends to the upper corner portions of the suspending-frame. A clevis 7 is loosely mounted in the cross-piece 1 and is connected with the ring 5 and is provided at its lower end with an eye through which pass the inner ends of safety-levers 8, pivoted intermediate of their ends to brackets pendent from the cross-piece 1. When the hoisting mechanism is intact, the inner ends of the safety-levers 8 are elevated a distance to hold the safety mechanism out of action.

A bar 9 is mounted for vertical movement upon the upper inner side of each upright 2, and its opposite edges are toothed, and its upper end is provided with an opening 10 to receive the outer end of the cooperating safety-lever 8. Cam-dogs 11 are provided in pairs and are arranged upon opposite sides of the respective guide-posts 4 and are attached to or provided with shafts 12, journaled in the uprights 2. These cam-dogs have their gripping edges or faces roughened, toothed, or serrated to prevent slipping and positively grip opposite sides of the guide-posts. A pinion 13 is provided at the inner end of each shaft 12 and is in mesh with a toothed portion of the cooperating toothed bar 9. The bar 9 operates between a pair of pinions 13, and rectilinear movement thereof causes a rotation of the shafts 12 and the cam-dogs 11 and throws the latter either into or out of action, according to the direction of movement of the toothed bar. When the clevis 7 is drawn upward by the hoisting rope or cable, the inner ends of the levers 8 are correspondingly lifted and their outer ends lowered, thereby moving the toothed bars 9 downward and turning the shafts 12, so as to throw the

cam-dogs 11 out of action, so as to clear the guide-posts, as shown most clearly in Fig. 2. Should the tension on the hoisting rope or cable become slack from any cause, as by  
 5 breakage or the slipping of the drive-belt, the clevis 7 will descend and lower the inner ends of the safety-levers 8 and move the toothed bars 9 upward and throw the cam-  
 10 dogs into action, whereby opposite sides of the guide-posts will be gripped and the platform or car held suspended. An upward pull upon the clevis will effect a release of the safety appliance and permit free movement of the platform or car, as will be readily com-  
 15 prehended.

The platform or cage 14 may be of any substantial construction and design and is mounted to tilt either to the right or to the left to effect dumping of the load. Rails 15 are lo-  
 20 cated upon the platform near opposite sides and support the car or truck 16, carrying the coal or other commodity. The platform is provided with a substantial substructure piv-  
 25 otally connected at its lower end with the uprights 2 of the suspending-frame. The substructure comprises side pieces 17 of approxi-  
 30 mately V form and connecting-braces 18 of X shape. Eyes 19 are provided at the lower ends of the side pieces 17 and receive a shaft  
 35 20, constituting the axes upon which the platform or car is adapted to turn. Bearings 21 are located at the lower ends of the uprights  
 40 2 and receive the ends of the shaft 20. Obviously the shaft 20 may be secured in the bearings 21, and the parts 19 constitute bear-  
 45 ings to turn upon the shaft 20. A rod or bar 22 is arranged at one end of the platform, and its ends project to form stops to limit the  
 50 tilting of said platform, as shown most clearly in Fig. 8. This rod or bar 22 may be located at either end of the platform, according to the  
 55 direction of tilting thereof. Hooks 23 are provided upon the inner ends of the uprights 2 and are positioned to engage with the pro-  
 60 jecting ends of the rod or bar 22 for cooperation therewith to limit the tilting movement of the platform. These hooks 23 constitute,  
 65 in effect, pivoted stops. Holders are arranged at the sides of the platform to prevent casual displacement of the truck or car 16 when the  
 70 platform is tilted, and, as shown, these holders consist of uprights 24, rigidly attached to the platform and having inwardly-extended  
 75 flanges 25 to project over the wheels of the car or truck and hold the same upon the rails. The uprights 24 are preferably plates bolted  
 80 to the platform and strengthened by braces, and the parts 25 are wings of angle-irons riveted or otherwise firmly attached to the up-  
 85 per ends of the parts 24. When the car or truck 16 is run upon the platform, the wheels thereof pass beneath the flanges 25, thereby  
 90 preventing vertical displacement or a pitching of the car from the platform when the latter is tilted to dump the load. Each end  
 95 of the platform is provided with chocks and a duplicate system of levers for securing the

car or truck when run upon the platform. These chocks are indicated at 26 and 26<sup>a</sup> and consist of bars slidably mounted in suitable  
 70 keepers 27 and 27<sup>a</sup>, applied to the platform. Hand-levers 28 and 28<sup>a</sup> extend lengthwise of the platform and are pivoted thereto at 29  
 75 and 29<sup>a</sup>, and their outer ends are readily accessible for convenience of operation when it is required to throw the chocks into or out of  
 80 operative position. The inner ends of the levers 28 and 28<sup>a</sup> have loose connection with corresponding chocks 26 and 26<sup>a</sup> and are con-  
 85 nected by links 30 and 30<sup>a</sup> with the other chocks by means of levers 31 and 31<sup>a</sup>. The chocks at one side of the platform are con-  
 90 nected by a lever 32, whereby movement imparted to one set of chocks at one end of the platform by means of the hand-lever is trans-  
 95 mitted to the other set of chocks at the opposite end of the platform, and vice versa. When one set of chocks is withdrawn, so as to  
 100 clear the rails and admit of the car or truck being run upon the platform, the opposite set of chocks project over the rails to arrest  
 105 the forward movement of the car when it reaches the proper position upon the platform. The chocks are arranged so as to extend over the  
 110 rails, and when both sets are thrown outward the car is prevented from leaving the platform at either end, and the chocks, in con-  
 115 junction with the holders 24, secure the car, as will be readily comprehended. The platform is held in a normal position by means  
 120 of catches 33, pivoted at a point between their ends to the uprights 2 and adapted to operate in vertical slots 34, formed therein. The  
 125 lower ends of the catches 33 are widened, as shown at 35, so as to lock the platform to the uprights by positive engagement with each,  
 130 a portion of the part 35 entering the slot 34 and a portion entering a notch or seat 36, provided at opposite sides of the platform.  
 135 The notches 36 are formed, preferably, by bends of strap-irons affixed to the sides of the platform, as shown most clearly in Fig. 3.  
 140 The upper end of each catch 33 is provided with a cross-piece 37, forming a T-head, and the arms of the parts 37 have their outer ends  
 145 outwardly bent, as shown at 38, to extend upon opposite sides of the uprights 2. Strips 39 are arranged at the sides of the guide-posts 4 and are adapted to be engaged by the bent  
 150 ends 38 of the catches 33 to automatically trip the latter and release the platform to admit of its automatic tilting to dump the load.  
 155 These strips 39 are arranged at the required elevation or point in the length of the guide-posts 4, so as to effect a dumping of the load  
 160 when the car or platform reaches the predetermined elevation above the surface of the ground or point at which it is required to  
 165 dump the load. In order to effect automatic action of the platform, the parts are arranged so that there is a preponderance of weight at  
 170 one side of the suspending-frame. Hence when the platform is released it will automatically tilt toward the side having the supe-

rior weight, the tilting being limited by co-  
operation of the stops 22 and 23 in the man-  
ner hereinbefore stated. After the load has  
been dumped the parts are reset by hand or  
5 in any manner that may be determined upon.

Having thus described the invention, what  
is claimed as new is—

1. In hoisting apparatus, and in combina-  
tion with the suspending-frame and tilting  
10 platform, vertically-disposed catches pivoted  
to the uprights and interlocked at their lower  
ends with the platform and said uprights to  
hold the platform in a horizontal position,  
and trips extended within the path of the up-  
15 per ends of the catches to effect disengage-  
ment of their lower ends from the platform,  
substantially as set forth.

2. In hoisting apparatus, and in combina-  
tion with the suspending-frame and tilting  
20 platform, catches pivoted to the uprights to  
engage with the platform and hold it in a  
given position and provided at their upper  
ends with T-heads, and means for engaging  
with the terminal portions of the T-heads and  
25 automatically releasing the catches from the  
platform to admit of a self-tilting thereof, sub-  
stantially as specified.

3. In hoisting apparatus, and in combina-  
tion with the suspending-frame and tilting  
30 platform, catches pivoted to the uprights to  
engage with the platform and hold it in a  
given position and provided at their upper  
ends with T-heads having their terminal por-  
tions bent to extend upon opposite sides of the  
35 guide-posts, and trips arranged at the sides of  
the guide-posts for engagement with the bent  
ends of the aforesaid T-heads to automatic-  
ally release the catches from the platform,  
substantially as set forth.

4. In hoisting apparatus, and in combina-  
tion with the suspending-frame having verti-  
cal slots in its uprights, and a tilting platform  
provided at opposite sides with notches to  
register with the slots of the uprights, catches  
45 pivoted to said uprights and having their

lower ends widened to enter the notches of  
the platform and the slots of the uprights and  
having oppositely-extended arms bent to ex-  
tend upon opposite sides of the uprights, and  
means for engaging with said bent ends to 50  
automatically trip the catches, substantially  
as described.

5. In hoisting apparatus, and in combina-  
tion with the platform, holders secured there-  
to and having inwardly-extended parts to en- 55  
gage over portions of the car or truck and  
prevent vertical displacement, pairs of chocks  
applied to the end portions of the platform to  
be projected across the path of the car in front  
and rear, the four chocks being separate and 60  
independent of one another, and means for  
moving the chocks of a pair in opposite di-  
rections and the pairs of chocks in opposite di-  
rections, substantially as described.

6. In hoisting apparatus, and in combina- 65  
tion with the platform, a pair of chocks for  
each end of the platform, the chocks of each  
pair being movable in opposite directions,  
and a system of levers for simultaneously  
moving the pairs of chocks and the individ- 70  
ual chocks in opposite directions, substan-  
tially as set forth.

7. In combination with a platform, a pair  
of chocks, an operating-lever pivoted inter-  
mediate of its ends and having an end por- 75  
tion connected with one of said chocks, a sec-  
ond lever pivoted at one end and having its  
opposite end in engagement with the other  
chock, and a link connecting the two levers,  
whereby the chocks are simultaneously moved 80  
in opposite directions, substantially as set  
forth.

In testimony whereof I affix my signature  
in presence of two witnesses.

DAVID W. <sup>his</sup> × JONES. [L. s.]  
mark

Witnesses:

C. D. HOPKINS,  
RICHARD JONES.