



INTERNATIONAL APPLICATION PUBLISHED UNDER THE PATENT COOPERATION TREATY (PCT)

<p>(51) International Patent Classification ⁷ : H01C 1/14, 17/28</p>	<p>A1</p>	<p>(11) International Publication Number: WO 00/30127 (43) International Publication Date: 25 May 2000 (25.05.00)</p>
<p>(21) International Application Number: PCT/US99/25280 (22) International Filing Date: 28 October 1999 (28.10.99) (30) Priority Data: 09/191,921 13 November 1998 (13.11.98) US (71) Applicant: BOURNS, INC. [US/US]; 1200 Columbia Avenue, Riverside, CA 92705 (US). (72) Inventors: BARRETT, Andrew, Brian; 16 The Downs, Douglas, Cork (IE). WALSH, Denis; 70 Silverdale Avenue, Ballinlough, Cork (IE). (74) Agents: KLEIN, Howard, J. et al.; Klein & Szekeres, LLP, Suite 700, 4199 Campus Drive, Irvine, CA 92612 (US).</p>	<p>(81) Designated States: AE, AL, AM, AT, AT (Utility model), AU, AZ, BA, BB, BG, BR, BY, CA, CH, CN, CR, CU, CZ, CZ (Utility model), DE, DE (Utility model), DK, DK (Utility model), DM, EE, EE (Utility model), ES, FI, FI (Utility model), GB, GD, GE, GH, GM, HR, HU, ID, IL, IN, IS, JP, KE, KG, KP, KR, KZ, LC, LK, LR, LS, LT, LU, LV, MD, MG, MK, MN, MW, MX, NO, NZ, PL, PT, RO, RU, SD, SE, SG, SI, SK, SK (Utility model), SL, TJ, TM, TR, TT, UA, UG, UZ, VN, YU, ZA, ZW, ARIPO patent (GH, GM, KE, LS, MW, SD, SL, SZ, TZ, UG, ZW), Eurasian patent (AM, AZ, BY, KG, KZ, MD, RU, TJ, TM), European patent (AT, BE, CH, CY, DE, DK, ES, FI, FR, GB, GR, IE, IT, LU, MC, NL, PT, SE), OAPI patent (BF, BJ, CF, CG, CI, CM, GA, GN, GW, ML, MR, NE, SN, TD, TG).</p> <p>Published <i>With international search report.</i></p>	

(54) Title: MULTILAYER CONDUCTIVE POLYMER DEVICE AND METHOD OF MANUFACTURING SAME

(57) Abstract

An electronic device includes two or more conductive polymer layers sandwiched between two external electrodes and one or more internal electrodes. A three-layer device is manufactured by: (1) providing a first laminated substructure comprising a first polymer layer between first and second metal layers, a second polymer layer, and a second laminated substructure comprising a third polymer layer between third and fourth metal layers; (2) forming first and second arrays of isolation apertures in the second and third metal layers, respectively; (3) laminating the first and second substructures to opposite surfaces of the second polymer layer; (4) forming first and second arrays of external electrodes in the first and fourth metal layers, respectively; (5) forming a plurality of first terminals, each connecting an external electrode in the second external electrode array to an electrode-defining area in the second metal layer, and a plurality of second terminals, each connecting an external electrode in the first external electrode array to an electrode-defining area in the third metal array; and (6) singulating the laminated structure into separate devices, each including a first polymer layer between a first external electrode and a first internal electrode, a second polymer layer between first and second internal electrodes, and a third polymer layer between the second internal electrode and a second external electrode. Each device includes a first terminal connecting the first internal electrode to the second external electrode, and a second terminal connecting the second internal electrode to the first external electrode.

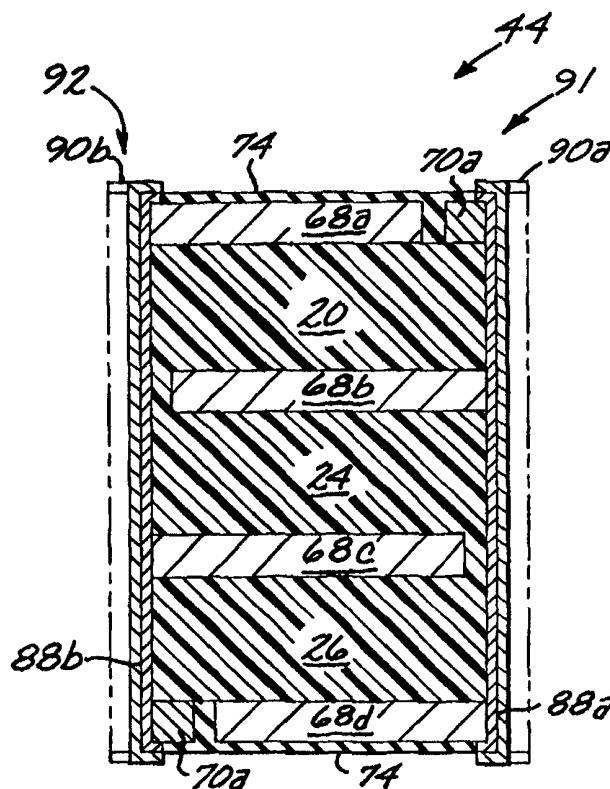

FOR THE PURPOSES OF INFORMATION ONLY

Codes used to identify States party to the PCT on the front pages of pamphlets publishing international applications under the PCT.

AL	Albania	ES	Spain	LS	Lesotho	SI	Slovenia
AM	Armenia	FI	Finland	LT	Lithuania	SK	Slovakia
AT	Austria	FR	France	LU	Luxembourg	SN	Senegal
AU	Australia	GA	Gabon	LV	Latvia	SZ	Swaziland
AZ	Azerbaijan	GB	United Kingdom	MC	Monaco	TD	Chad
BA	Bosnia and Herzegovina	GE	Georgia	MD	Republic of Moldova	TG	Togo
BB	Barbados	GH	Ghana	MG	Madagascar	TJ	Tajikistan
BE	Belgium	GN	Guinea	MK	The former Yugoslav Republic of Macedonia	TM	Turkmenistan
BF	Burkina Faso	GR	Greece	ML	Mali	TR	Turkey
BG	Bulgaria	HU	Hungary	MN	Mongolia	TT	Trinidad and Tobago
BJ	Benin	IE	Ireland	MR	Mauritania	UA	Ukraine
BR	Brazil	IL	Israel	MW	Malawi	UG	Uganda
BY	Belarus	IS	Iceland	MX	Mexico	US	United States of America
CA	Canada	IT	Italy	NE	Niger	UZ	Uzbekistan
CF	Central African Republic	JP	Japan	NL	Netherlands	VN	Viet Nam
CG	Congo	KE	Kenya	NO	Norway	YU	Yugoslavia
CH	Switzerland	KG	Kyrgyzstan	NZ	New Zealand	ZW	Zimbabwe
CI	Côte d'Ivoire	KP	Democratic People's Republic of Korea	PL	Poland		
CM	Cameroon	KR	Republic of Korea	PT	Portugal		
CN	China	KZ	Kazakstan	RO	Romania		
CU	Cuba	LC	Saint Lucia	RU	Russian Federation		
CZ	Czech Republic	LI	Liechtenstein	SD	Sudan		
DE	Germany	LK	Sri Lanka	SE	Sweden		
DK	Denmark	LR	Liberia	SG	Singapore		
EE	Estonia						

1	4,413,301 - Middleman et al.
2	4,426,633 - Taylor
3	4,445,026 - Walker
4	4,481,498 - McTavish et al.
5	4,545,926 - Fouts, Jr. et al.
6	4,639,818 - Cherian
7	4,647,894 - Ratell
8	4,647,896 - Ratell
9	4,685,025 - Carlomagno
10	4,774,024 - Deep et al.
11	4,689,475 - Kleiner et al.
12	4,732,701 - Nishii et al.
13	4,769,901 - Nagahori
14	4,787,135 - Nagahori
15	4,800,253 - Kleiner et al.
16	4,849,133 - Yoshida et al.
17	4,876,439 - Nagahori
18	4,884,163 - Deep et al.
19	4,907,340 - Fang et al.
20	4,951,382 - Jacobs et al.
21	4,951,384 - Jacobs et al.
22	4,955,267 - Jacobs et al.
23	4,980,541 - Shafe et al.
24	5,049,850 - Evans
25	5,140,297 - Jacobs et al.
26	5,171,774 - Ueno et al.
27	5,174,924 - Yamada et al.
28	5,178,797 - Evans

- 1 5,181,006 - Shafe et al.
- 2 5,190,697 - Ohkita et al.
- 3 5,195,013 - Jacobs et al.
- 4 5,227,946 - Jacobs et al.
- 5 5,241,741 - Sugaya
- 6 5,250,228 - Baigrie et al.
- 7 5,280,263 - Sugaya
- 8 5,358,793 - Hanada et al.

9 One common type of construction for conductive polymer PTC devices
10 is that which may be described as a laminated structure. Laminated
11 conductive polymer PTC devices typically comprise a single layer of
12 conductive polymer material sandwiched between a pair of metallic electrodes,
13 the latter preferably being a highly-conductive, thin metal foil. See, for
14 example, U.S. Patents Nos. 4,426,633 - Taylor; 5,089,801 - Chan et al.;
15 4,937,551 - Plasko; and 4,787,135 - Nagahori; and International Publication
16 No. WO97/06660.

17 A relatively recent development in this technology is the multilayer
18 laminated device, in which two or more layers of conductive polymer material
19 are separated by alternating metallic electrode layers (typically metal foil),
20 with the outermost layers likewise being metal electrodes. The result is a
21 device comprising two or more parallel-connected conductive polymer PTC
22 devices in a single package. The advantages of this multilayer construction
23 are reduced surface area ("footprint") taken by the device on a circuit board,
24 and a higher current-carrying capacity, as compared with single layer devices.

25 In meeting a demand for higher component density on circuit boards,
26 the trend in the industry has been toward increasing use of surface mount
27 components as a space-saving measure. Surface mount conductive polymer
28 PTC devices heretofore available have been generally limited to hold currents

1 below about 2.5 amps for packages with a board footprint that generally
2 measures about 9.5 mm by about 6.7 mm. Recently, devices with a footprint
3 of about 4.7 mm by about 3.4 mm, with a hold current of about 1.1 amps, have
4 become available. Still, this footprint is considered relatively large by current
5 surface mount technology (SMT) standards.

6 The major limiting factors in the design of very small SMT conductive
7 polymer PTC devices are the limited surface area and the lower limits on the
8 resistivity that can be achieved by loading the polymer material with a
9 conductive filler (typically carbon black). The fabrication of useful devices
10 with a volume resistivity of less than about 0.2 ohm-cm has not been practical.
11 First, there are difficulties inherent in the fabrication process when dealing
12 with such low volume resistivities. Second, devices with such a low volume
13 resistivity do not exhibit a large PTC effect, and thus are not very useful as
14 circuit protection devices.

15 The steady state heat transfer equation for a conductive polymer PTC
16 device may be given as:

17 (1)
$$0 = [I^2 R(f(T_d))] - [U(T_d - T_a)],$$

18 where **I** is the steady state current passing through the device; **R(f(T_d))** is the
19 resistance of the device, as a function of its temperature and its characteristic
20 "resistance/temperature function" or "R/T curve"; **U** is the effective heat
21 transfer coefficient of the device; **T_d** is temperature of the device; and **T_a** is the
22 ambient temperature.

23 The "hold current" for such a device may be defined as the maximum
24 value of **I** guaranteed not to trip the device from a low resistance state to a
25 high resistance state. For a given device, where **U** is fixed, the only way to
26 increase the hold current is to reduce the value of **R**. A hold current of 1.1A
27 should be achievable for a single layer device, 1.8A for a two layer device and
28 2.6A for a three-layer polymer PTC device each having a footprint of 4.5mm

1 by 3.2mm.

2 The governing equation for the resistance of any resistive device can be
3 stated as:

4 (2)
$$R = \rho L / A,$$

5 where ρ is the volume resistivity of the resistive material in ohm-cm, L is the
6 current flow path length through the device in cm, and A is the effective cross-
7 sectional area of the current path in cm^2 . Thus, the value of R can be reduced
8 either by reducing the volume resistivity ρ , or by increasing the cross-sectional
9 area A of the device. The value of the volume resistivity ρ can be decreased
10 by increasing the proportion of the conductive filler loaded into the polymer.

11 The practical limitations of doing this, however, are noted above.

12 A more practical approach to reducing the resistance value R is to
13 increase the cross-sectional area A of the device. Besides being relatively easy
14 to implement (from both a process standpoint and from the standpoint of
15 producing a device with useful PTC characteristics), this method has an
16 additional benefit: In general, as the area of the device increases, the value of
17 the heat transfer coefficient also increases, thereby further increasing the value
18 of the hold current.

19 In SMT applications, however, it is necessary to minimize the effective
20 surface area or footprint of the device. This puts a severe constraint on the
21 effective cross-sectional area of the PTC element in device. Thus, for a device
22 of any given footprint, there is an inherent limitation in the maximum hold
23 current value that can be achieved. Viewed another way, decreasing the
24 footprint can be practically achieved only by reducing the hold current value.

25 There has thus been a long-felt, but as yet unmet, need for very small
26 footprint SMT conductive polymer PTC devices that achieve relatively high
27 hold currents.

28

1 SUMMARY OF THE INVENTION

2 Broadly, the present invention is a conductive polymer PTC device that
3 has a relatively high hold current while maintaining a very small circuit board
4 footprint. This result is achieved by a multilayer construction that provides an
5 increased effective cross-sectional area A of the current flow path for a given
6 circuit board footprint. In effect, the multilayer construction of the invention
7 provides, in a single, small-footprint surface mount package, two or more PTC
8 devices electrically connected in parallel.

9 In one aspect, the present invention is a conductive polymer PTC
10 device comprising, in a preferred embodiment, multiple alternating layers of
11 metal foil and PTC conductive polymer material, with electrically conductive
12 interconnections to form two or more conductive polymer PTC devices
13 connected to each other in parallel, and with termination elements configured
14 for surface mount termination.

15 Specifically, two of the metal layers form, respectively, first and second
16 external electrodes. The remaining metal layers form a plurality of internal
17 electrodes that physically separate and electrically connect two or more
18 conductive polymer layers located between the external electrodes. The
19 electrodes are staggered to create two sets of alternating electrodes: a first set
20 that is in electrical contact with the first terminal, and a second set that is in
21 electrical contact with the second terminal. One of the terminals serves as an
22 input terminal, and the other serves as an output terminal.

23 A first embodiment of the invention comprises a three layer conductive
24 polymer device having first, second, and third conductive polymer layers. In a
25 preferred embodiment, the conductive polymer exhibits PTC characteristics.
26 A first external electrode is in electrical contact with a first terminal and with
27 an exterior surface of the first conductive polymer layer that is opposed to the
28 surface facing the second conductive polymer layer. A second external

1 electrode is in electrical contact with a second terminal and with an exterior
2 surface of the third conductive polymer layer that is opposed to the surface
3 facing the second conductive polymer layer. The first and second conductive
4 polymer layers are separated by a first internal electrode that is in electrical
5 contact with the second terminal, while the second and third conductive
6 polymer layers are separated by a second internal electrode that is in electrical
7 contact with the first terminal.

8 In such an embodiment, if the first terminal is an input terminal and the
9 second terminal is an output terminal, the current flow path is from the first
10 terminal to the first external electrode and to the second internal electrode.
11 From the first external electrode, current flows through the first conductive
12 polymer layer to the first internal electrode and then to the second terminal.
13 From the second internal electrode, current flows through the second
14 conductive polymer layer to the first internal electrode and then to the second
15 terminal, and through the third conductive polymer layer to the second
16 external electrode and then to the second terminal.

17 Thus, the resulting device is a three layer device in which three layers
18 of conductive polymer (preferably PTC) are connected in parallel. This
19 construction provides the advantages of a significantly increased effective
20 cross-sectional area for the current flow path, as compared with a single layer
21 device, without increasing the footprint. Thus, for a given footprint, a larger
22 hold current can be achieved. Alternatively, devices with only two conductive
23 polymer layers, or with four or more such layers, can be fabricated, with
24 similar benefits and advantages. Another aspect of the present
25 invention is a method of fabricating the above-described devices. For a device
26 having three conductive polymer layers, this method comprises the steps of:
27 (1) providing (a) a first laminated substructure comprising a first conductive
28 polymer layer sandwiched between first and second metal layers, (b) a second

1 conductive polymer layer, and (c) a second laminated substructure comprising
2 a third conductive polymer layer sandwiched between third and fourth metal
3 layers; (2) forming first and second arrays of isolation apertures in
4 corresponding areas of the second and third metal layers; (3) laminating the
5 first and second laminated substructures to opposite surfaces of the second
6 conductive polymer layer to form a laminated structure comprising the first
7 conductive polymer layer sandwiched between the first and second metal
8 layers, the second conductive polymer layer sandwiched between the second
9 and third metal layers, and the third conductive polymer layer sandwiched
10 between the third and fourth metal layers, the isolation apertures being filled
11 with polymer as a result of the lamination; (4) isolating selected areas in the
12 first and fourth metal layers to form first and second arrays of external
13 electrodes in the first and fourth metal layers, respectively, the external
14 electrodes in each array being separated from each other by isolated contact
15 areas; (5) forming a plurality of first terminals and a plurality of second
16 terminals, each of the first terminals electrically connecting one of the
17 electrodes in the second external electrode array to a defined area in the
18 second metal layer through a via in a polymer-filled isolation aperture in the
19 third metal layer, and each of the second terminals electrically connecting one
20 of the electrodes in the first external electrode array to a defined area in the
21 third metal layer through a via in a polymer-filled isolation aperture in the
22 second metal layer; and (6) separating the laminated structure into a plurality
23 of devices, each comprising two external electrodes and two internal
24 electrodes, a first terminal electrically connecting one external electrode to one
25 internal electrode, and a second terminal electrically connecting the other
26 external electrode to the other internal electrode.

27 The step of forming the first and second terminals comprises the steps
28 of (a) forming vias at spaced intervals in the laminated structure, each of the

1 vias intersecting an external electrode in each of the first and second external
2 arrays and one of either the second or third (internal) metal layers, and passing
3 through one of either the first or second arrays of isolation apertures; (b)
4 plating the peripheral surfaces of the vias and adjacent surface portions of the
5 isolated metal areas in the first and second external arrays with a conductive
6 metal plating; and (c) overlaying a solder plating over the metal-plated
7 surfaces.

8 The separation step of the fabrication process comprises the step of
9 singulating the laminated structure into a plurality of individual conductive
10 polymer devices, each of which has the structure described above.

11 In a second embodiment, a two layer device comprises a first and a
12 second terminal, and first and second conductive polymer layers. Each
13 conductive polymer layer has first and second opposed surfaces. The first and
14 second conductive polymer layers are separated by a single internal electrode
15 that is in electrical contact with the first terminal, with the second surface of
16 the first conductive polymer layer and with the first surface of the second
17 conductive polymer layer. The first external electrode is in electrical contact
18 with the second terminal and with the first surface of the first conductive
19 polymer layer. A second external electrode is in electrical contact with the
20 second terminal and with the second surface of the second conductive polymer
21 layer.

22 In a more particular embodiment of the two layer device, the second
23 terminal is connected to the second external electrode through a via in a
24 polymer-filled isolation aperture in the internal electrode, and the first terminal
25 is in electrical contact with the internal electrode, while being isolated from
26 the first and second external electrodes.

27 The two layer electronic device is formed by providing a first laminated
28 substructure comprising a first conductive polymer layer sandwiched between

1 a first and second metal layers, and a second laminated substructure
2 comprising a second layer of conductive polymer material laminated to a third
3 metal layer. An array of isolation apertures is formed in the first metal layer.
4 The first and second laminated substructures are then laminated so as to create
5 a laminated structure, the isolation apertures becoming filled with polymer
6 during the lamination. The laminated structure has a first conductive polymer
7 layer sandwiched between the first and second metal layers, and a second
8 conductive polymer layer sandwiched between the first and third metal layers.
9 A first array of external electrodes is then formed in the third metal layer, and
10 a second array of external electrodes is formed in the second metal layer. The
11 external electrodes in the second and third metal layers are vertically aligned
12 and registered with each other. The polymer-filled isolation apertures in the
13 first metal layer are horizontally staggered between the external electrodes in
14 the second and third metal layers. The laminated structure is then drilled to
15 form vias (at least some of which pass through the polymer-filled isolation
16 apertures), the vias are plated through to form a plurality of first and second
17 terminals, and the structure is parceled into a plurality of two layer electronic
18 devices, each having a single first terminal and a single second terminal.

19 During the process of formation, a plurality of first terminals is formed,
20 each of which is in electrical contact with the first metal layer. Also, a
21 plurality of second terminals is formed, each of which electrically connects the
22 second and third metal layers to each other through a via in a polymer-filled
23 isolation aperture in the first metal layer. After parceling, each electronic
24 device produced has first and second polymer layers that operate in parallel
25 between the first and second terminal.

26 In yet another embodiment, a four layer device comprises first, second,
27 third, and fourth conductive polymer layers. The first and fourth conductive
28 polymer layers are separated by a first internal electrode that is in electrical

1 contact with a first terminal. The first and second conductive polymer layers
2 are separated by a second internal electrode that is in electrical contact with a
3 second terminal. The second and third conductive polymer layers are
4 separated by a third internal electrode that is in electrical contact with the first
5 terminal.

6 A first external electrode is in electrical contact with the second
7 terminal and with an exterior surface of the third conductive polymer layer that
8 is opposed to the surface facing the second conductive polymer layer. A
9 second external electrode is in contact with an exterior surface of the fourth
10 conductive polymer layer that is opposed to the surface facing the first
11 conductive polymer layer.

12 The device has a first terminal that electrically connects the first and
13 third internal electrodes through a via in an isolation aperture in the second
14 internal electrode. The device has a second terminal that electrically connects
15 the first external electrode to the second internal electrode through a via in a
16 polymer-filled isolation aperture in the third internal electrode, and to the
17 second external electrode through a via in a polymer-filled isolation aperture
18 in the first internal electrode.

19 The method for making a four layer device having four conductive
20 polymer layers, is similar to that for a three layer device except that a third
21 laminated substructure, comprising a fifth metal layer laminated to a fourth
22 conductive polymer layer, is additionally provided in the first step. The
23 method then proceeds as follows (from the second step):

24 (2) Forming first, second, and third arrays of isolation apertures in
25 corresponding areas of the first, second, and third metal layers, respectively;

26 (3) Laminating the first and second laminated substructures to opposite
27 surfaces of the second conductive polymer layer and laminating the fourth
28 conductive polymer layer to the first metal layer to form a laminated structure

1 comprising the first conductive polymer layer sandwiched between the first
2 and second metal layers, the second conductive polymer layer sandwiched
3 between the second and third metal areas, the third conductive polymer layer
4 sandwiched between the third layer and the fourth metal layer, and the fourth
5 conductive polymer layer sandwiched between the first and fifth metal layers
6 (the fourth and fifth metal layers being external metal layers); (4)

7 Isolating selected areas of the fourth and fifth metal layers to form first and
8 second arrays of isolated external electrodes in the fourth and fifth (external)
9 metal layers, the electrodes in each of the first and second electrode arrays
10 being separated from each other by an array of isolated contact areas;

11 (5) Forming a plurality of first terminals, each electrically connecting a
12 defined area in the first metal layer to a defined area in the third metal layer,
13 and forming a plurality of second terminals, each electrically connecting a
14 defined area in the second metal layer to one of the external electrodes in the
15 first external electrode array and to one of the external electrodes in the second
16 external electrode array; and

17 (6) separating the laminated structure into a plurality of individual
18 devices, each comprising two external electrodes and three internal electrodes,
19 a single first terminal in electrical contact with two external electrodes and one
20 internal electrode, and a single second terminal in electrical contact with the
21 other two internal electrodes.

22 The above-mentioned advantages of the present invention, as well as
23 others, will be more readily appreciated from the detailed description that
24 follows.

25

26

BRIEF DESCRIPTION OF THE DRAWINGS

27 Figure 1 is a top plan view of a laminated structure fabricated in
28 accordance with the present invention;

1 Figure 2 is an idealized cross-sectional view of the top and bottom
2 laminated substructures and a middle conductive polymer layer, illustrating the
3 first step in making a conductive polymer device in accordance with the
4 method of the present invention;

5 Figures 3a - 3d are idealized plan views of a portion of the first, second,
6 third and fourth metal layers of the laminated structure of Figure 1, showing
7 their respective etch patterns;

8 Figure 4 is an idealized cross-sectional view, similar to that of Figure 2,
9 after the performance of the step of creating first and second internal arrays of
10 isolation apertures in the second and third metal layers of the laminated
11 substructures of Figure 2;

12 Figure 5 is an idealized cross-sectional view showing the composite
13 laminated structure formed after the lamination of the first and second
14 substructures and the middle conductive polymer layer of Figure 2;

15 Figure 6 is a cross-sectional view of the laminated structure of Figure 5,
16 after the performance of the step of creating first and second external arrays of
17 isolation channel pairs respectively in the first and fourth metal layers shown
18 in Figure 2;

19 Figure 7 is a top plan view of the structure of Figure 6 showing the first
20 external array of isolation channel pairs registered in a pattern of grid lines and
21 subsequent to the formation of vias;

22 Figure 8 is a cross-sectional view taken along line 8 - 8 of Figure 7,
23 showing vias passing through isolation apertures;

24 Figure 9 is a top plan view of the laminated structure, after the
25 performance of the step of depositing an insulative coating on the surface to
26 form insulative isolation areas on the external metal areas;

27 Figures 10a and 10b are cross-sectional views, taken along line 10 - 10
28 of Figure 9, respectively prior to and subsequent to the step of metal-plating

1 the vias and adjacent surface portions of the external metal areas;

2 Figure 11 is a cross-sectional view, similar to that of Figures 10b, after
3 the step of plating the metallized surfaces with solder;

4 Figure 12a is a top plan view of the laminated structure of Figure 9,
5 after the steps of Figures 10a, 10b, 11, showing the step of singulating by
6 cutting the laminated structure along the previously etched score lines, on the
7 external surfaces, to form a plurality of individual conductive polymer
8 devices;

9 Figure 12b is a top plan view of a singulated conductive polymer device
10 selected from the devices shown in Figure 12a;

11 Figure 13 is a cross-sectional view taken along line 13 - 13 of Figure
12 12b;

13 Figure 14 is an idealized cross-sectional view of a conductive polymer
14 layer with a metal layer on a first surface, and a laminated substructure
15 provided as a first step in making a two-layer conductive polymer device;

16 Figure 15 is an idealized cross-sectional view, similar to that of Figure
17 14, with a first array of isolation apertures having been formed in the first
18 metal layer;

19 Figure 16 is an idealized cross-sectional view of a laminated structure,
20 after the step of laminating the components shown in Figure 15, showing a
21 first array of isolation apertures within the laminated structure;

22 Figure 17 is an idealized cross-sectional view, similar to that of Figure
23 16, showing external arrays of isolated metal areas formed in the third and
24 second metal layers;

25 Figure 18 is a cross-sectional view of a singulated two layer conductive
26 polymer device in accordance with the present invention;

27 Figure 19 is an idealized cross-sectional view of the laminated
28 substructures and an unlaminated internal conductive polymer layer provided

1 as a first step in making a four layer conductive polymer device in accordance
2 with the present invention;

3 Figure 20 is an idealized cross-sectional view, similar to that of Figure
4 19, showing first, second and third internal arrays of isolation apertures
5 formed in the first, second and third metal layers of the laminated the
6 substructures;

7 Figure 21 is an idealized cross-sectional view showing the laminated
8 structure formed by the lamination of the components shown in Figure 20;

9 Figure 22 is an idealized cross-sectional view, similar to that of Figure
10 21, showing external arrays of isolated metal areas formed in the fourth and
11 fifth external metal layers; and

12 Figure 23 is a cross-sectional view of a singulated four layer conductive
13 polymer device, in accordance with the present invention.

14

15 DETAILED DESCRIPTION OF THE INVENTION

16 Referring now to the drawings, Figure 1 is a plan view of a first
17 laminated substructure 10 stacked above an unseen second laminated
18 substructure 12 (shown in Figure 2). A conductive polymer layer of
19 conductive polymer material (also unseen) is interposed between the first
20 laminated substructure 10 and the second laminated substructure 12. The first
21 laminated substructure 10, the second laminated substructure 12 and the layer,
22 of conductive polymer material are shown in Figure 2 in an exploded sectional
23 view taken across an arbitrary region 16 of Figure 1 bordered by dashed lines.
24 Registration holes 18 penetrate the first laminated substructure 10, the second
25 laminated substructure 12 and the layer of conductive polymer material and
26 provide for positive alignment of the respective layers when alignment pins
27 (not shown) are inserted therein.

28 Figure 2 shows the first laminated substructure 10, and the second

1 laminated substructure 12. Providing the first and second laminated
2 substructures 10, 12 is an initial step in the process of fabricating a conductive
3 polymer device in accordance with the present invention. The first laminated
4 substructure 10 comprises a first conductive polymer layer 20 of conductive
5 polymer material sandwiched between first and second metal layers 22a, 22b.
6 A second conductive polymer layer 24 (or middle layer) of conductive
7 polymer material is provided for lamination between the first substructure 10
8 and the second substructure 12 in a subsequent step in the process, as will be
9 described below. The second substructure 12 comprises a third conductive
10 polymer layer 26 of conductive polymer PTC material sandwiched between
11 third and fourth metal layers 28a, 28b.

12 The first, second and third layers 20, 24, 26 may be made of any
13 suitable conductive polymer composition, such as, for example, high density
14 polyethylene (HDPE) or polyvinylidene difluoride (PVDF), into which is
15 mixed an amount of a conductive filler (preferably carbon black) that results in
16 the desired electrical operating characteristics. Preferably, the conductive
17 polymer material is formulated so as to exhibit PTC characteristics in
18 accordance with a desired set of operational criteria and specifications. Other
19 materials, such as antioxidants and/or cross-linking agents, may also be mixed
20 into the composition. The particular types of the constituent materials, and
21 their proportions, depend upon the specific electrical and mechanical
22 characteristics and specifications desired. See, for example, U.S. Patents Nos.
23 4,237,441 - van Konynenburg et al. and 5,174,924 - Yamada et al.

24 The laminated substructures 10, 12 may be fabricated by a number of
25 methods well-known in the art. See, for example, U.S. Patents Nos. 4,426,633
26 - Taylor; 5,089,801 - Chan et al.; 4,937,551 - Plasko; and 4,787,135 -
27 Nagahori. A preferred method is disclosed in U.S. Patent No. 5,802,709 -
28 Hogge et al., assigned to the assignee of the present invention, the disclosure

1 of which is incorporated herein by reference.

2 The metal layers 22a, 22b, 28a, and 28b may be made of copper or
3 nickel foil, with nickel being preferred for the second and third (internal) metal
4 layers 22b, 28a. If the metal layers 22a, 22b, 28a, and 28b are made of copper
5 foil, those foil surfaces that contact the conductive polymer layers are coated
6 with a nickel flash coating (not shown) to prevent unwanted chemical
7 reactions between the polymer and the copper. These polymer contacting
8 surfaces are also preferably "nodularized", by well-known techniques, to
9 provide a roughened surface that provides good adhesion between the metal
10 and the polymer. Thus, the second and third (internal) metal layers 22b, 28a
11 are both nodularized surfaces, while the first and fourth (external) metal layers
12 22a, 28b are nodularized only on the single surface that contacts an adjacent
13 conductive polymer layer.

14 Registration holes represent one means for maintaining the
15 substructures 10, 12 and the second layer 24 of conductive polymer in the
16 proper relative orientation or registration for carrying out the subsequent steps
17 in the fabrication process. Preferably, this is done by forming (e.g., by
18 punching or drilling) a plurality of registration holes 18 in the corners of the
19 substructures 10, 12 and the middle polymer layer 24, as shown in Figure 1.
20 Other registration techniques, well known in the art, may also be used.

21 Figures 3a - 3d depict patterns that are etched through the first, second,
22 third and fourth metal layers 22a, 22b, 28a, and 28b respectively, in the course
23 of the following process steps. A first set of grid lines 36 and a second set grid
24 lines 38, formed perpendicularly with the first set 36, are etched into both the
25 first and fourth metal layers, as shown in Figures 3a and 3d. The grid lines
26 36, 38 form an orthogonal grid that is shown in Figures 3a-3d to illustrate how
27 the patterns of features shown in these figures are registered with respect to
28 each other. The grid lines 36, 38 are etched in the external (first and fourth)

1 metal layers 22a, 28b only, so as to form score lines that are used for
2 singulating the laminated structure that is formed from the components shown
3 in Figure 2 into individual conductive polymer PTC devices, as described
4 below. The grid lines 36, 38 delineate arrays of rectangular metal areas or
5 "parcels" on each of the respective metal layers at corresponding locations
6 with respect to the registration holes 18, that identify the limits of individual
7 devices to be later formed. In Figure 3c, brackets 40 show the dimensions to
8 be assumed by an individual device (after singulation, as described below), as
9 defined by the grid lines 36, 38 and the area contained therebetween. While
10 the grid lines 36, 38 appear only on the first and fourth metal layers 22a, 28b
11 (Figures 3a and 3d), they are shown in phantom outline in Figures 3b and 3c to
12 assist in understanding the relative locations of the other structures shown in
13 these drawings.

14 Figure 3a shows a first array of external isolation channels 46 formed in
15 the first metal layer 22a. Figure 3b shows a first internal array of isolation
16 apertures 48 formed in the second metal layer 22b. Figure 3c shows a second
17 internal array of isolation apertures 52 formed in the third metal layer 28a.
18 Figure 3d shows a second array of external isolation channels 46 formed in the
19 fourth metal layer 28b.

20 Subsequent to scoring the resulting laminated structure along the score
21 lines defined by the grid lines 36, 38, as described below, the first array of
22 external isolation channels 46 forms a first external array of isolated metal
23 areas 60 in the first metal layer 22a, separated by metal islands 61 (Figure 3a),
24 and a second external array of isolated metal areas 62, separated by metal
25 islands 63, in the fourth metal layer 28b (Figure 3d). The first set of score
26 lines 36 bisects each of the first external array isolated metal areas 60 (in the
27 first metal layer 22a) and each of the second external array of isolated metal
28 areas 62 (in the fourth metal layer 28b).

1 Figures 3a, 3b 3c, and 3d depict a pattern of drill holes or vias 64 to be
2 applied to the resulting laminated structure. The via centers are shown as
3 addressed or registered on the centers of first and second internal arrays of
4 isolation apertures 48, 52, respectively. The location of the via centers is
5 common to the centers of the first and second internal arrays of isolation
6 apertures 48, 52 in the second and third metal layers, respectively, and it is
7 also common to the centers of the first and second arrays of metal islands 61,
8 63 in the first and fourth metal layers, respectively. The via locations on the
9 first and fourth metal layers 22a, 28b are indicated by dashed circles mapped
10 onto the metal island areas 61, 63 of Figures 3a and 3d, respectively. In the
11 preferred embodiment, all of the vias 64 are drill holes. The diameter of the
12 vias 64 is sufficiently smaller than the etched diameter of the isolation
13 apertures 48, 52 so as to ensure isolation when the vias 64 are later metallized,
14 as described below.

15 Figures 4 - 6 depict, in cross-sectional views similar to that of Figure 2,
16 the successive steps of forming the etched features described above and
17 illustrated in Figures 3a-3d. First, as shown in Figure 4, a first array of
18 internal isolation apertures 48 (only one of which is shown in Figure 4),
19 registered in accordance with the grid patterns of Figures 3b, is formed in the
20 second metal layer 22b. A second array of internal isolation apertures 52,
21 registered in accordance with the grid patterns of Figures 3c, is formed in the
22 third metal layer 28a. As shown in Figures 3b, 3c, and 4, the first and second
23 internal arrays of isolation apertures 48, 52 are registered in alternating parcels
24 or metal areas defined by the grid lines 36, 38. Specifically, the internal
25 isolation apertures 48 in the first array are positioned on an alternating grid
26 with index locations that are between the positions of the internal isolation
27 apertures 52 in the second array.

28 The removal of metal from the second and third metal layers 22b, 28a

1 to form the first and second arrays of internal isolation apertures 48, 52 is
2 accomplished by conventional printed circuit board fabrication methods such
3 as those techniques employing photoresist, masks and etching methods.

4 Figure 5 shows a laminated structure 42 that is the result of laminating
5 the substructures 10, 12 and the middle conductive polymer layer 24 after
6 ensuring that the layers are in proper registration. The middle conductive
7 polymer layer 24 is laminated between the substructures 10, 12 by a suitable
8 laminating method, as is well known in the art. The lamination may be
9 performed, for example, under suitable pressure and at a temperature above
10 the melting point of the conductive polymer material, whereby the material of
11 the conductive polymer layers 20, 24 and 26 flows into and fills the first
12 internal array of isolation apertures 48 and the second internal array of
13 isolation apertures 52. The laminate 42 is then cooled to below the melting
14 point of the polymer while maintaining pressure. At this point, the polymeric
15 material in the laminated structure 42 may be cross-linked, by well-known
16 methods, if desired for the particular application in which the device will be
17 employed. The drill holes or vias 64 may then be formed in the laminate 42 at
18 any time after the laminate 42 has cooled.

19 Figure 6 shows the result of masking and etching the external surfaces
20 of the first and fourth metal layers of the laminated structure 42 with the
21 patterns of the first and fourth metal layers of Figure 3a and 3d, respectively,
22 to form the first and second arrays of isolation channels 46 in the first and
23 fourth metal layers 22a, 28b, respectively. The isolation channels 46 of
24 Figures 3a and 3d, which appear as parallel pairs of channels in Figure 6,
25 operate, in combination with the grid lines 36, 38, to form a first external array
26 of isolated major metal areas 60, separated by isolated contact areas or
27 "islands" 61, in the first metal layer 22a, and a second external array of
28 isolated major metal areas 62, separated by isolated contact areas or "islands"

1 63, in the fourth metal layer 28b. By way of example, one of the metal islands
2 61 in Figure 3a is hatched with dots to show the perimeter of an individual
3 metal island 61. The isolated major metal areas 60 of first the external array
4 are staggered so that each of the first external isolated metal areas 60 overlies a
5 position between the first array of internal isolation apertures 48, and the
6 isolated major metal areas 62 of the second external array are staggered so that
7 each of the second external isolated metal areas 62 overlies a position between
8 a second internal array of internal isolation apertures 52.

9 Each of the first internal isolation apertures 48 in the second metal layer
10 22b overlies a position between the second internal isolation apertures 52 in
11 the third metal layer 28a and underlies a position between the first external
12 isolated metal areas 60 on the first metal layer 22a. Each of the second
13 internal isolation apertures 52 in the third metal layer 28a underlies a position
14 between the first internal isolation apertures 48 in the second metal layer 22b
15 and overlies a position between the second external isolated metal areas 62 on
16 the fourth metal layer 28b.

17 The shape, size, and pattern of the external arrays of isolation channels
18 46 and the first and second internal isolation apertures 48, 52 will be dictated
19 by the need to optimize the electrical isolation between the metal areas. The
20 etched pattern of the first and second internal isolation apertures 48, 52 is
21 chosen to minimize the reduction in strength of the metal layer after etching.
22 It is important to minimize the risk of foil rupture or ripping during the
23 lamination process. An alternating etch pattern (as shown in Figures 3b, 3c) is
24 advantageously chosen instead of a pattern of rows to minimize the risk of
25 rupture or tearing of inner metal foil layers during the lamination process. The
26 amount of material etched in forming isolation apertures or in forming
27 isolation channels for the isolated metal areas should also be kept to a
28 minimum to obtain a maximum "active area" on the electrodes that are

1 formed from these areas (as described below) for a given footprint. However,
2 it is necessary to design the isolation apertures and channels so as to provide
3 sufficient clearances so that slight misregistrations between the layers normal
4 in the manufacturing process does not lead to electrical shorts. In the
5 illustrated embodiment, the external isolation channels 46 are in the form of
6 pairs of narrow parallel bands, each pair of channels having a pair of opposed
7 arcs 65 in the vicinity of each of the vias 64 (see Figure 7).

8 Figures 7 through 10a illustrate the next few steps in the fabrication
9 process, which are performed with the laminated structure 42 oriented by
10 means of the registration holes 18 as shown in connection with Figure 1. As
11 shown in Figure 7, the grid lines 36, 38 have been formed, as by chemical
12 etching, across at least one, and preferably both, of the external surfaces of the
13 laminated structure 42. The first set of grid lines 36 comprises a parallel array
14 of lines that are generally parallel to the external isolation channels 46, and are
15 spaced at uniform intervals through the center lines of the vias 64, thereby
16 bisecting each of the islands 61 and each of the isolated metal areas 60. The
17 second set of grid lines 38 comprises a parallel array of lines that
18 perpendicularly intersect the first set of grid lines 36 at regularly-spaced
19 intervals, dividing the first external metal layer 22a and the fourth metal layer
20 28b into a grid of substantially rectangular device areas, with each device area
21 defining the external surface limits of an individual conductive polymer
22 device. Each device area defined in the first metal layer 22a is partitioned by a
23 single isolation channel 46 into a first major external metal area 68a and a first
24 minor area 70a. Each device area defined in the fourth metal layer 28b is
25 partitioned by a single isolation channel 46 into a second major external metal
26 area 68d and a second external minor area 70d. Thus, each external major area
27 68, 68d is bounded on one side by a grid line 36 separating it from an
28 adjoining major external metal area 68, 68d, and on the opposite side by an

1 isolation channel 46, while each external minor area 70a, 70d is bounded on
2 one side by an isolation channel 46 and a grid line 36 separating it from an
3 adjoining external minor area 70a, 70d.

4 Referring to Figures 7 and 8, the grid lines 36, 38, in combination with
5 the isolation channels 46 on the first and fourth external metal layers 22a, 28b,
6 form a plurality of first and second external major areas 68a, 68d and first and
7 second external minor areas 70a and 70d on the first and fourth metal layers
8 22a, 22b, respectively. Specifically, each of the islands 61, 63 is bisected by a
9 grid line 36 into a pair of adjoining external minor metal areas 70a, 70b,
10 respectively, while each of the external major areas 68a, 68d is likewise
11 bisected by a grid line 36. Furthermore, each of the major metal areas 68a,
12 68d is separated from an adjacent external minor area 70a, 70d, by an isolation
13 channel 46.

14 The grid lines 36, 38, in combination with the isolation apertures 48,
15 52, also define areas of the second metal layer 22b and the third metal layer
16 28a that form a plurality of first internal metal areas 68b in the second metal
17 layer 22b, and a plurality of second internal metal areas 68c in the third metal
18 layer 28a. The first external major metal areas 68a in the first metal layer 22a
19 are in substantial vertical alignment with the second internal metal areas 68c in
20 the third metal layer 28a, and the first internal metal areas 68b in the second
21 metal layer 22b are in substantial vertical alignment with the second external
22 major metal areas 68d in the fourth metal layer 28b.

23 The metal areas 68a, 68b 68c, 68d will serve as electrode elements in an
24 individual device. More specifically, the first external major areas 68a will
25 serve as first external electrodes, the first internal areas 68b will serve as first
26 internal electrodes, the second internal electrodes, and the second external
27 major areas 68d will serve as second external electrodes. Hereinafter, the
28 metal areas 68a, 68b 68c, 68d will be referred to, respectively, as the first

1 external electrodes 68a, the first internal electrodes 68b, the second internal
2 electrodes 68c, and the second external electrodes 68d.

3 As shown in Figures 7 and 8, a plurality of through-holes or "vias" 64 is
4 punched or drilled through the laminated structure 42 at regularly-spaced
5 intervals along each of the first set of grid lines 36, preferably approximately
6 mid-way between each adjacent pair of the second set of grid lines 38.

7 Because the first and second internal isolation apertures 48, 52 are staggered,
8 as described above, the electrodes 68a, 68b 68c, 68d are also staggered
9 relative to each other, as best shown in Figure 8. Moreover, each of the vias
10 64 extends through only one of the internal isolation apertures, with successive
11 vias 64 extending alternately through a first isolation aperture 48 and a second
12 isolation aperture 52. Specifically, referring to Figure 8, a first via 64' extends
13 through the juncture of two adjoining first minor areas 70a, the juncture of two
14 adjoining first internal electrodes 68b, a second internal isolation electrode 52,
15 and the juncture of two adjoining second external electrodes 68d. A second
16 via 64" extends through the juncture of two adjoining first external electrodes
17 68a, a first internal isolation aperture 48, the juncture of two adjoining second
18 internal electrodes 68c, and the juncture of two second minor areas 70b.

19 Figures 9 and 10a show a thin isolating layer 74 of electrically
20 insulating material, such as a glass-filled epoxy resin, that is formed (as by
21 screen printing) on each of the external major surfaces of the laminated
22 structure 42 (i.e., the top and bottom surfaces, as viewed in the drawings). The
23 isolating layers 74 are applied so as to cover the isolation channels 46 and all
24 but narrow peripheral edges of the first and second external electrodes 68a,
25 68d and narrow peripheral edges of the first and second minor metal areas 70a,
26 70b.

27 The resulting pattern of the thin isolating layers 74 leaves a series of
28 exposed strips of metal 78 on the external surfaces of the laminated structure

1 42, as shown in Figure 10a, with each strip 78 presenting a regular sequence of
2 enlarged contact regions centered on the first set of grid lines 36 on the top and
3 bottom major surfaces of the laminated structure 42. The arcs 65 in the
4 isolation channels 46 define a "bulge" around each of the vias 64, so that each
5 via 64 is completely surrounded by exposed metal, as best shown in Figure 9.
6 The isolating layers 74 are then cured by the application of heat, as is well
7 known in the art.

8 The specific order of the three major fabrication steps described above
9 in connection with Figures 6 through 9 may be varied, if desired. For
10 example, the isolation layers 74 may be applied either before or after the vias
11 64 are formed, and the scoring step for forming the grid lines 36, 38 may be
12 performed as the first, second or third of these steps.

13 Next, as shown in Figure 10b, all exposed metal surfaces (i.e. the series
14 of exposed strips of metal 78) and the internal surfaces of the vias 64 are
15 coated with a plating 80 of conductive metal, such as tin, nickel, or copper,
16 with copper being preferred. This metal plating step can be performed by any
17 suitable process, such as electrodeposition, for example. Then, as shown in
18 Figure 11, the areas that were metal-plated in the previous step are again
19 plated with a thin solder coating 82. The solder coating 82 can be applied by
20 any suitable process that is well-known in the art, such as reflow soldering or
21 vacuum deposition.

22 Finally, as shown in Figures 12a, 12b, and 13, the laminated structure
23 42 is singulated (by well-known techniques) along the grid lines 36, 38 to form
24 a plurality of individual conductive polymer devices 44, one of which is
25 shown in Figures 12b and in the sectional view of Figure 13 taken on section
26 line 13 - 13 of Figure 12b. Because each of the first set of grid lines 36 passes
27 through a succession of vias 64 in the laminated structure 42, as shown in
28 Figure 7, each of the devices 44 formed after singulation has a pair of opposed

1 sides 84a, 84b, each of which includes a half via.

2 The metal plating and the solder plating of the vias 64, described above,
3 create first and second conductive vertical columns 88a, 88b in the half vias on
4 the opposed sides 84a, 84b, respectively. Figure 13 shows that the first
5 conductive column 88a is in intimate physical contact with the first internal
6 electrode 68b and the second external electrode 68d. The second conductive
7 column 88b is in intimate physical contact with the first external electrode 68a
8 and the second internal electrode 68c. The first conductive column 88a is also
9 in contact with the first minor metal area 70a, while the second conductive
10 column 88b is in contact with the second minor metal area 70b. The minor
11 metal areas 70a, 70b (as best shown in Figure 8) are of such small area as to
12 have a negligible current-carrying capacity, and thus do not function as
13 electrodes, as will be seen below.

14 Figures 12a, 12b, and 13 also show that each device 44 includes first
15 and second pairs of metal-plated and solder-plated conductive strips 90a, 90b
16 along opposite edges of its top and bottom surfaces. The first and second pairs
17 of conductive strips 90a, 90b are respectively contiguous with the first and
18 second conductive columns 88a, 88b. The first pair of conductive strips 90a
19 and the first conductive column 88a form a first terminal 91, and the second
20 pair of conductive strips 90b and the second conductive column 88b form a
21 second terminal 92. The first terminal 91 provides electrical contact with the
22 first internal electrode 68b and the second external electrode 68d, while the
23 second terminal 92 provides electrical contact with the first external electrode
24 68a and the second internal electrode 68c. The first terminal 90a is electrically
25 isolated from the second internal electrode 68c by the polymeric material that
26 had filled the second array of internal isolation apertures 52 during the
27 lamination step of the process, as described above. Similarly, the second
28 terminal 90b is electrically isolated from the first internal electrode 68b by the

1 polymeric material that had filled the first array of isolation apertures 48
2 during the lamination step.

3 For the purposes of this description, the first terminal 91 may be
4 considered an input terminal and the second terminal 92 may be considered an
5 output terminal, but these assigned roles are arbitrary, and the opposite
6 arrangement may be employed. The current paths from the input terminal 91
7 to the output terminal 92 of the three layer device 44 in Figure 13 is as
8 follows: (a) Through the first internal electrode 68b, the first conductive
9 polymer PTC layer 20, and the first external electrode 68a; (b) through the
10 second external electrode 68d, the third conductive polymer layer 26, and the
11 second internal electrode 68c; and (c) through the first internal electrode 68b,
12 the second (middle) conductive polymer layer 24, and the second internal
13 electrode 68c. This current flow path is equivalent to connecting the three
14 conductive polymer PTC layers 20, 24, and 26 in parallel between the input
15 and output terminals 91, 92.

16 The fabrication method described above for a three layer device can
17 adapted to make two and four layer devices, or devices with more than four
18 layers. A two layer device provides two conductive polymer layers operating
19 in parallel. Such a device would have a higher resistance than a comparably
20 sized three layer device but it would also be less complex and therefore, less
21 costly to make. A four layer device would be more complex but will provide
22 an additional reduction in resistance for a given size than a three layer device,
23 but at a higher cost due to the added complexity.

24 Figures 14-18 illustrate the steps in the method of manufacturing a two
25 layer device. Referring first to Figure 14, a first laminated substructure 94 is
26 shown, along with a second laminated substructure 95 on top of the first
27 laminated substructure 94. The first and second substructures 94, 95 are
28 provided as the initial step in the process of fabricating a two layer conductive

1 polymer PTC device in accordance with the present invention.

2 The first laminated substructure 94 comprises a first layer of conductive
3 polymer material 96 sandwiched between first and second metal layers 98a,
4 98b. The second laminated substructure 95 comprises a second layer of
5 conductive polymer material 99 with a third metal layer 98c laminated to its
6 upper surface (as oriented in the drawings). The second metal layer 98b and
7 the third metal layer 98c are the "external" metal layers, as shown in Figures
8 14 - 18.

9 The metal layers 98a, 98b, 98c are made of nickel foil (preferred for the
10 internal layer 98a) or copper foil with a nickel flash coating. Those surfaces of
11 the metal layers that are to come into contact with a conductive polymer layer
12 are preferably nodularized, as described above in connection with the metal
13 layers 22a, 22b, 28a, and 28b for the three layer device.

14 The second and subsequent steps in the method of manufacturing a two
15 layer device are analogous to the steps illustrated in Figures 4-12, discussed
16 above, for manufacturing a three layer device. Figure 15 shows the step of
17 forming an array of internal isolation apertures 100 in the first metal layer 98a.
18 The internal isolation apertures 100 (only one of which is shown in the
19 drawings), are registered in accordance with the grid patterns previously
20 characterized by Figures 3a-3d. That is, they are registered in alternating
21 parcels defined by the grid lines 36, 38 (Figure 7). The metal removal from
22 the first metal layer 98a to form the array of internal isolation apertures 100 is
23 accomplished by conventional printed circuit board fabrication methods, such
24 as those techniques employing photoresist, masks, and etching methods.

25 Figure 16 shows the next step of laminating the first substructure 94 to
26 the second laminated substructure 95 so as to create a laminated structure 101,
27 which is analogous to the laminated structure 42 described above in
28 connection with Figure 5. The laminated structure 101 comprises the first

1 conductive polymer layer 96 sandwiched between the first metal layer 98a and
2 second metal layer 98b, and the second conductive polymer layer 99
3 sandwiched between the first metal layer 98a and the third metal layer 98c.

4 Figure 17 shows the laminated structure after the next step of forming
5 arrays of external isolated metal areas 102, 104 in the second and third metal
6 layers 98b, 98c, respectively. (Only one each of the areas 102, 104 is shown
7 in the drawings.) The isolated metal areas 102 in the second metal layer 98b
8 and the isolated metal areas 104 in the third metal layer 98c are registered in
9 substantial vertical alignment, i.e., one above the other. The array of internal
10 isolation apertures 100 in the first metal layer 98a is registered between the
11 isolated metal areas 102, 104 in the second and third metal layers 98b, 98c.
12 The isolated metal areas 102, 104 are formed by arrays of isolation channels
13 107 formed in the second and third metal layers 98b, 98c. The isolation
14 channels 107 are analogous to the isolation channels 46 described above in
15 connection with the three layer device 44. As in the above-described three
16 layer device 44, and analogous to the structure described above in connection
17 with Figure 6, the pattern of the isolation channels 107 results in the isolated
18 metal areas 102 of the second metal layer 98b being separated by isolated
19 contact areas or "islands" 108, and the isolated metal areas 104 of the third
20 metal layer 98c being separated by metal islands 109. The arrays of isolation
21 apertures 100, the arrays of isolated metal areas 102, 104, the pattern of the
22 isolation channels 107, and the arrays of metal islands 108, 109 are all
23 patterned with respect to a pattern of grid lines, such as the grid lines 36, 38
24 described above in connection with Figures 3a-3d.

25 The laminated structure 101 is then processed in accordance with the
26 steps described above in connection with Figures 7-12b. Figure 18
27 schematically shows a resulting completed two layer device 111 in section
28 after the step of singulation described above in connection with Figures 12a

1 and 12b. The two layer device 111 has a first terminal 105 and a second
2 terminal 106, each of which comprises a conductive metal plating 80 and a
3 solder coating 82, as described above. The first metal layer 98a is formed into
4 a middle or internal electrode 112a, the second metal layer 98b is formed into
5 a first outer electrode 112b, and the third metal layer 98 is formed into a
6 second outer electrode 112c.

7 As with the case of three layer devices, the electrodes are made of a
8 metal foil made of a material selected from the group consisting of nickel and
9 nickel-coated copper. An insulating layer 74 is shown on the first external
10 electrode 112b excluding the first terminal 105 and on the surface of the
11 second external electrode 112c excluding the second terminal 106.

12 The first terminal 105 is in contact with first and second minor metal
13 areas 114a, 114b that are separated from the first and second outer electrodes
14 112a, 112b, respectively, by the isolation channels 107. The first terminal 105
15 establishes electrical contact with the internal electrode 112a, while the second
16 terminal 106 is in electrical contact with the first and second external
17 electrodes 112b, 112c.

18 Figure 18 thus shows a two layer electronic device 111 having a first
19 (input) terminal 105 and a second (output) terminal 106, in which electrical
20 current passes from the first terminal 105 to the second terminal 106 through
21 the middle electrode 112a, and then through (a) the first conductive polymer
22 layer 96 and the first external electrode 112b; and (b) the second conductive
23 polymer layer 99 and the second external electrode 112c. Of course, the
24 device 111 can also provide the reverse current path if the second terminal 106
25 is defined as the input terminal and the first terminal 105 is defined as the
26 output terminal.

27 It is apparent that the fabrication method described above may be easily
28 adapted to the manufacture of a device having any number of conductive

1 polymer layers greater than two. Figures 19 through 23 illustrate specifically
2 how the fabrication method of the present invention may be modified to
3 manufacture a device having four conductive polymer layers. For illustrative
4 purposes only, the first few steps in the manufacture of a four layer device will
5 be described. Figures 19 - 23 are schematic representations only intended to
6 draw on the above discussion of the process steps illustrated in Figures 1
7 through 13.

8 Figure 19 illustrates a first laminated substructure 115a, a second
9 laminated substructure 115b, and a third laminated substructure 115c on top of
10 the first laminated substructure 115a. The first, second, and third substructures
11 115a, 115b, 115c are provided as the initial step in the process of fabricating a
12 four layer conductive polymer device in accordance with the present
13 invention. The first laminated substructure 115a comprises a first layer 116 of
14 conductive polymer material sandwiched between first and second metal
15 layers 118a, 118b. A second conductive polymer layer 120 is provided for
16 placement between the first substructure 115a and the second substructure
17 115b. The second laminated substructure 115b comprises a third conductive
18 polymer layer 122 sandwiched between third and fourth metal layers 118c,
19 118d. The third substructure 115c comprises a fourth layer 124 of conductive
20 polymer material with a fifth metal layer 118e laminated to its upper surface
21 (as oriented in the drawings). The fifth metal layer 118e and the fourth metal
22 layer 118d are the "external" metal layers, as shown in Figures 19 - 21. The
23 metal layers 118a-118e are made of nickel foil (preferred for the internal
24 layers 118a, 118b, 118c) or copper foil with a nickel flash coating, and those
25 surfaces of the metal layers that are to come into contact with a conductive
26 polymer layer are preferably nodularized, as mentioned above.

27 The subsequent process steps are analogous to those discussed above
28 with respect to Figures 3a *et seq.* Specifically, Figure 20 a shows that a first

1 array of internal isolation apertures 127a, registered in accordance with a
2 pattern of grid lines (such as the grid lines 36, 38 of Figures 3b-3d), is formed
3 in the first metal layer 118a. A second array of internal isolation apertures
4 127b, registered in accordance with the grid lines, is formed in the second
5 internal metal layer 118b. The first array of internal isolation apertures 127a
6 in the first metal layer 118a and the second array of internal isolation apertures
7 127b in the second metal layer 118b are registered in alternating parcels
8 defined by the grid lines 36, 38. A third array of internal isolation apertures
9 127c is formed in the third metal layer 118c. The isolation apertures 118c in
10 the third array are aligned with and in registration with the apertures 127a in
11 the first array. The metal removal from the first, second, and third metal
12 layers 118a, 118b, 118c to form the first, second, and third arrays of isolation
13 apertures 127a, 127b, 127c is accomplished by conventional printed circuit
14 board fabrication methods, such as those techniques employing photoresist,
15 masks and etching methods.

16 Referring to Figure 21, while ensuring that the substructures 115a,
17 115b, 115c, and the second conductive polymer layer 120 are in proper
18 registration, these substructures and the second conductive polymer layer 120
19 are laminated together to form a laminated structure 130. The lamination may
20 be performed, for example, under suitable pressure and at a temperature above
21 the melting point of the conductive polymer material, whereby the material of
22 the conductive polymer layers 116, 120, 122, and 124 flows into and fills the
23 isolation apertures 127a, 127b, and 127c. The laminate is then cooled to
24 below the melting point of the polymer while maintaining pressure. At this
25 point, the polymeric material in the laminated structure 130 may be cross-
26 linked, by well-known methods, if desired for the particular application in
27 which the device will be employed.

28 Referring now to Figure 22, after the laminated structure 130 of Figure

1 21 has been formed, arrays of external isolation channels 46 are etched into the
2 fourth metal layer 118d (the first or bottom external metal layer) and the fifth
3 metal layer 118e (the second or top external metal layer). As explained above,
4 in connection with Figures 3a and 3d and Figure 6 - 8, the isolation channels
5 46 appear as parallel pairs of channels or brackets. The formation of the
6 external isolation channels 46 in the fourth and fifth metal layers 118d, 118e
7 creates, in combination with parceling along the grid lines 36, 38 (shown in
8 Figures 3a, 3d, and 7), a first external array of isolated major metal areas 60 on
9 the fifth metal layer 118e and a second external array of isolated major metal
10 areas 62 on the fourth metal layer 118d. The isolation channels 46 also create
11 a first array of metal islands 61 between each adjacent pair of major metal
12 areas 60 in the fifth metal layer 118e, and a second array of metal islands
13 between each adjacent pair of major metal areas 62 in the fourth metal layer
14 118d.

15 The isolated major metal areas 60 in the fifth metal layer 118e are
16 staggered so that each of them overlies a position between a pair of the internal
17 isolation apertures 127a. The isolated major metal areas 62 in the fourth metal
18 layer 118d are staggered so that each of them underlies a position between a
19 pair of internal isolation apertures 127c in the third array. Each internal
20 isolation aperture 127a in the first metal layer 118a overlies a position between
21 internal isolation apertures 127b in the second metal layer 118b. Each internal
22 isolation aperture 127b in the second metal layer 118b underlies a position
23 between first internal isolation apertures 127a in the first metal layer 118a and
24 overlies a position between internal isolation apertures 127c in the third metal
25 layer 118c. Each of the internal isolation apertures 127a in the first array also
26 underlies a position directly below a first external isolated major metal area 60
27 in the fifth metal layer 118e and overlies a position directly above a second
28 external isolated major metal area 62 in the fourth metal layer 118d. As will

1 be seen, the arrays of external major metal areas 60, 62 provide pluralities of
2 first and second external electrodes, and the first, second, and third (internal)
3 metal layers provide a plurality of first, second, and third internal electrodes,
4 respectively.

5 Referring now to Figure 23, the fabrication process proceeds as
6 describe above with reference to Figures 8-13. After singulation, the result is
7 a device 150 that is similar to that shown in Figures 12b and 13, except that
8 there are four conductive polymer layers separated by three internal electrodes.
9 The resulting device 150 is electrically equivalent to four conductive polymer
10 elements connected in parallel between an input terminal an output terminal.

11 Specifically, the device 150 comprises first, second, third, and fourth
12 conductive polymer layers 116, 120, 122, 124 respectively. The first and
13 fourth conductive polymer layers 116, 124 are separated by a first internal
14 electrode 132a that is in electrical contact with a first terminal 156a. The first
15 and second conductive polymer layers 116, 120 are separated by a second
16 internal electrode 132b that is in electrical contact with a second terminal
17 156b. The second and third conductive polymer layers 120, 122 are separated
18 by a third internal electrode 132c that is in electrical contact with the first
19 terminal 156a. A first external electrode 132d is in electrical contact with the
20 second terminal 156b and with a surface of the third conductive polymer layer
21 122 that is opposed to the surface facing the second conductive polymer layer
22 120. A second external electrode 132e is in electrical contact with the second
23 terminal 156b and with a surface of the fourth conductive polymer layer 124.
24 The opposite surface of the conductive polymer layer 124 faces the first
25 conductive polymer layer 116. Insulative isolation layers 138, similar to the
26 insulation layers 74, described above with reference to Figure 9 and Figure 10,
27 cover the portions of the external electrodes 132d, 132e between the terminals
28 156a, 156b. The terminals 156a, 156b are formed by the metal plating and

1 solder plating steps described above with reference to Figures 10b and 11.

2 If the first terminal 156a is arbitrarily chosen as an input terminal, and
3 the second terminal 156b is arbitrarily chosen as the output terminal, the
4 current path through the device 150 is as follows: From the input terminal
5 156a, current enters the first and third internal electrodes 132a, 132c. From
6 the first internal electrode 132a, current flows (a) through the fourth
7 conductive polymer layer 124 and the second external electrode 132e to the
8 output terminal 156b; and (b) through the first conductive polymer PTC layer
9 116 and the second internal electrode 132b to the output terminal 156b. From
10 the third internal electrode 132c, current flows (a) through the second
11 conductive polymer layer 120 and the second internal electrode 132b to the
12 output terminal 156b; and (b) through the third conductive polymer layer 122
13 and the first external electrode 132d to the output terminal 156b.

14 It will be appreciated that the device constructed in accordance with the
15 above described fabrication process is very compact, with a small footprint,
16 and yet it can achieve relatively high hold currents.

17 While exemplary embodiments have been described in detail in this
18 specification and in the drawings, it will be appreciated that a number of
19 modifications and variations may suggest themselves to those skilled in the
20 pertinent arts. For example, the fabrication process described herein may be
21 employed with conductive polymer compositions of a wide variety of
22 electrical characteristics, and is thus not limited to those exhibiting PTC
23 behavior. Furthermore, while the present invention is most advantageous in
24 the fabrication of SMT devices, it may be readily adapted to the fabrication of
25 multilayer conductive polymer devices having a wide variety of physical
26 configurations and board mounting arrangements. These and other variations
27 and modifications are considered the equivalents of the corresponding
28 structures or process steps explicitly described herein, and thus are within the

- 1 scope of the invention as defined in the claims that follow.

1 WHAT IS CLAIMED IS:

2 1. A method of fabricating an electronic device, comprising the steps
3 of:

4 (1) providing (a) a first laminated substructure comprising a first
5 conductive polymer layer sandwiched between first and second metal layers,
6 (b) a second conductive polymer layer, and (c) a second laminated
7 substructure comprising a third conductive polymer layer sandwiched between
8 third and fourth metal layers;

9 (2) forming first and second arrays of internal isolation apertures in
10 corresponding areas in the second and third metal layers;

11 (3) laminating the first and second laminated substructures to opposite
12 surfaces of the second conductive polymer layer to form a laminated structure;

13 (4) forming an array of first external electrodes in the first metal layer
14 and an array of second external electrodes in the fourth metal layer;

15 (5) forming a plurality of first terminals and a plurality of second
16 terminals, each of the first terminals electrically connecting one of the second
17 external electrodes to a defined area of the second metal layer through an
18 isolation aperture in the third metal layer, and each of the second terminals
19 electrically connecting one of the first external electrodes to a defined area of
20 the third metal layer through an isolation aperture in the second metal layer;
21 and

22 (6) separating the laminated structure into a plurality of devices, each
23 comprising a first terminal and a second terminal.

24

25 2. The method of Claim 1, wherein the metal layers are made of a
26 metal foil.

27

28 3. The method of Claim 1, wherein the step of forming the first and

1 second internal arrays of isolation apertures in the second and third metal
2 layers comprises the step of removing selected portions of the second and third
3 metal layers; and

4 wherein the step of forming the arrays of first and second external
5 electrodes comprises the step of removing selected portions of the first and
6 fourth metal layers.

7

8 4. The method of Claim 3, wherein the steps of removing selected
9 portions of the first, second, third, and fourth metal layers are performed so
10 that each of the first external electrodes is in substantial vertical alignment
11 with a defined area of the third metal layer, and so that each of the second
12 external electrodes is in substantial vertical alignment with a defined area of
13 the second metal layer.

14

15 5. The method of Claim 4, wherein the step of forming the pluralities
16 of first and second terminals comprises the steps of:

17 (5)(a) forming a first plurality of vias through the laminated structure,
18 each passing through one of the internal isolation apertures in the first array,
19 and forming a second plurality of vias through the laminated structure, each
20 passing through one of the internal isolation apertures in the second array; and

21 (5)(b) metallizing the interior surface of each of the vias in the first and
22 second plurality of vias.

23

24 6. The method of Claim 5, wherein the step of metallizing comprises
25 the steps of:

26 (5)(b)(i) plating the interior via surfaces with a metal selected from the
27 group consisting of tin, nickel, and copper; and

28 (5)(b)(ii) coating the plated interior via surfaces with solder.

1 7. The method of Claim 5, further comprising, after the step of forming
2 the vias and before the step of metallizing, the step of forming an isolation
3 layer of insulative material on each of the first and fourth metal layers, the
4 isolation layers being formed so as to leave exposed a portion of each metal
5 layer adjacent each of the vias.

6

7 8. The method of Claim 7, wherein the isolation layers are formed of
8 glass-filled epoxy resin.

9

10 9. The method of Claim 7, wherein the step of metallizing is performed
11 so as to metallize the exposed portions of each metal layer adjacent each of the
12 vias.

13

14 10. An electronic device, comprising:

15 a first terminal and a second terminal;

16 a first electrode in electrical contact with the first terminal;

17 and

18 first and second conductive polymer layers, each having a first surface
19 in electrical contact with the first electrode and a second surface electrically
20 connected to the second terminal.

21

22 11. The electronic device of Claim 10, further comprising:

23 a second electrode in physical contact with the second surface of the
24 first conductive polymer layer and electrically connected to the second
25 terminal; and

26 a third electrode in physical contact with the second surface of the
27 second conductive polymer layer and electrically connected to the second
28 terminal.

1

2 12. The electronic device of Claim 11, wherein the second electrode
3 has first and second opposed surfaces, the first surface of the second electrode
4 being in physical contact with the second surface of the first conductive
5 polymer layer, the device further comprising:

6 a third conductive polymer layer having a first surface in physical
7 contact with the second surface of the second electrode and a second surface in
8 electrical contact with the first terminal.

9

10 13. The electronic device of Claim 12, further comprising:

11 a fourth electrode in physical contact with the second surface of the
12 third conductive polymer layer and in electrical contact with the first terminal.

13

14 14. The electronic device of Claim 11, wherein the first electrode is
15 electrically isolated from the second terminal by conductive polymer, and
16 wherein the second and third electrodes are electrically isolated from the first
17 terminal by conductive polymer.

18

19 15. The electronic device of Claim 11, wherein the first, second, and
20 third electrodes are made of a metal foil.

21

22 16. An electronic device, comprising:

23 first and second terminals;

24 first, second, and third conductive polymer layers, each having first and
25 second opposed surfaces;

26 the first and second conductive polymer layers being separated by a
27 first internal electrode that is in electrical contact with the first terminal, the
28 second surface of the first conductive polymer layer and the first surface of the

1 second conductive polymer layer;
2 the second and third conductive polymer layers being separated by a
3 second internal electrode that is in electrical contact with the second terminal,
4 the second surface of the second conductive polymer layer, and the first
5 surface of the third conductive polymer layer;

6 a first external electrode in electrical contact with the second terminal
7 and with the first surface of the first conductive polymer layer; and

8 a second external electrode in electrical contact with the first terminal
9 and with the second surface of the third conductive polymer layer.

10

11 17. The electronic device of Claim 16, further comprising:

12 a first insulating layer on the first external electrode excluding the first
13 terminal; and

14 a second insulating layer on the second external electrode excluding the
15 second terminal.

16

17 18. The electronic device of Claim 17, wherein the insulating layer is
18 made of glass-filled epoxy resin.

19

20 19. The electronic device of Claim 16, wherein each of the first and
21 second terminals comprises:

22 a first layer formed of a metal selected from the group consisting of tin,
23 nickel, and copper; and

24 a second layer formed of solder.

25

26 20. The electronic device of Claim 16, wherein the first and second
27 external electrodes and the first and second internal electrodes are made of a
28 metal foil.

1 21. An electronic device, comprising:
2 first and second terminals;
3 first and second conductive polymer layers, each having first and
4 second opposed surfaces;
5 the first and second conductive polymer layers being separated by an
6 internal electrode that is in electrical contact with the first terminal, the second
7 surface of the first conductive polymer layer, and the first surface of the
8 second conductive polymer layer;
9 a first external electrode being in electrical contact with the second
10 terminal and with the first surface of the first conductive polymer layer; and
11 a second external electrode being in electrical contact with the second
12 terminal and with the second surface of the second conductive polymer layer.

13

14 22. The electronic device of Claim 21, wherein the internal electrode
15 and the first and second external electrodes are made of a metal foil.

16

17 23. The electronic device of Claim 21, further comprising:
18 a first insulating layer on the first external electrode excluding the first
19 terminal; and
20 a second insulating layer on the second external electrode excluding the
21 second terminal.

22

23 24. A laminated structure for parceling into a plurality of electronic
24 devices, each electronic device having a first terminal and a second terminal,
25 the structure comprising:

26 a first conductive polymer layer sandwiched between first and second
27 metal layers, and a second conductive polymer layer sandwiched between the
28 first metal layer and a third metal layer;

1 an array of polymer-filled isolation apertures formed in the first metal
2 layer;
3 a first array of isolated metal areas in the third metal layer; and
4 a second array of isolated metal areas in the second metal layer, the
5 isolated metal areas in the second and third metal layers being registered with
6 each other in substantial vertical alignment, the array of polymer-filled
7 isolation apertures in the first metal layer being registered between the isolated
8 metal areas in the second and third metal layers;
9 a plurality of first terminals, each of which is in electrical contact with
10 the first metal layer, while being electrically isolated from the isolated metal
11 areas in the second and third metal layers; and
12 a plurality of second terminals, each of which electrically connects an
13 isolated metal area in the second metal layer to an isolated metal area in the
14 third metal layer through a polymer-filled isolation aperture in the first metal
15 layer.

16
17 25. A method of fabricating an electronic device, comprising the
18 steps of:

19 (1) providing (a) a first laminated substructure comprising a first
20 conductive polymer layer sandwiched between first and second metal layers,
21 and (b) a second laminated substructure comprising a second conductive
22 polymer layer laminated to a third metal layer;

23 (2) forming an array of internal isolation apertures in the first metal
24 layer;

25 (3) laminating the first and second laminated substructures together so
26 as to create a laminated structure comprising the first conductive polymer
27 layer sandwiched between the first and second metal layers, and the second
28 conductive polymer layer sandwiched between the third and first metal layers,

1 with the isolation apertures being filled with conductive polymer material as a
2 result of the laminating step;

3 (4) forming a first array of external electrodes in the third metal layer,
4 and a second array of external electrodes in the second metal layer, the
5 external electrodes in the first and second external electrode arrays being
6 registered in substantial vertical alignment with each other, the polymer-filled
7 isolation apertures in the first metal layer being registered between the external
8 electrodes in the first and second external electrode arrays;

9 (5) forming a plurality of first terminals, each of which is in electrical
10 contact with a defined area in the first metal layer, while being electrically
11 isolated from the external electrodes in the first and second external electrode
12 arrays; and

13 (6) forming a plurality of second terminals, each of which electrically
14 connects an external electrode in the first external electrode array to an
15 external electrode in the second external electrode array through a polymer-
16 filled isolation aperture in the first metal layer.

17

18 26. The method of Claim 25, further comprising the step of:

19 (7) separating the laminated structure into a plurality of electronic
20 devices, each of which includes a first terminal and a second terminal.

21

22 27. A method of fabricating an electronic device, comprising the steps
23 of:

24 (1) providing (a) a first laminated substructure comprising a first
25 conductive polymer layer sandwiched between first and second metal layers,
26 (b) a second conductive polymer layer, and (c) a second laminated
27 substructure comprising a third conductive polymer layer sandwiched between
28 third and fourth metal layers, and (d) a third laminated substructure comprising

1 a fourth layer of conductive polymer material laminated to a fifth metal layer;
2 (2) forming first, second, and third arrays of internal isolation apertures
3 in the first, second, and third metal layers, respectively;
4 (3) laminating the first and second laminated substructures to opposite
5 surfaces of the second conductive polymer layer and laminating the third
6 substructure to the first laminated substructure so as to create a laminated
7 structure comprising the first conductive polymer layer sandwiched between
8 the first and second metal layers, the second conductive polymer layer
9 sandwiched between the second and third metal layers, the third conductive
10 polymer layer sandwiched between the third and fourth metal layers, and the
11 fourth conductive polymer layer sandwiched between the first and fifth metal
12 layers;
13 (4) forming a first array of external electrodes in the fifth metal layer
14 and a second array of external electrodes in the fourth metal layer, whereby the
15 external electrodes in the first and second external electrode arrays are
16 registered in substantial vertical alignment with the isolation apertures in the
17 second internal electrode array, and whereby the isolation apertures in the first
18 and third aperture arrays are in substantial vertical alignment with each other;
19 (5) forming a plurality of first terminals, each first terminal electrically
20 connecting a defined area in the first metal layer with a defined area in the
21 third metal layer through a polymer-filled isolation aperture in the second
22 aperture array; and
23 (6) forming a plurality of second terminals, each second terminal
24 electrically connecting an external electrode in the second external electrode
25 array to a defined area in the second metal layer through a polymer-filled
26 isolation aperture in the first aperture array, and to an external electrode in the
27 first external electrode array through a polymer-filled isolation aperture in the
28 third aperture array.

1 28. The method of Claim 27, wherein the metal layers are made of a
2 metal foil.

3

4 29. The method of Claim 27, wherein the separating step comprises the
5 step of:

6 (7) separating the laminated structure into a plurality of devices, each
7 having a first conductive polymer layer sandwiched between a first external
8 electrode and a first internal electrode, a second conductive polymer layer
9 sandwiched between a first internal electrode and a second internal electrode, a
10 third conductive polymer layer sandwiched between a second internal
11 electrode and a third internal electrode and a fourth conductive polymer layer
12 sandwiched between a third internal electrode and a second external electrode,
13 with each of the first terminals being in electrical contact only with the first
14 and third internal electrodes and each of the second terminals only being in
15 electrical contact with the first and second external electrodes and the second
16 internal electrode.

17

18 30. The method of Claim 27, wherein the steps of forming the
19 pluralities of first and second terminals comprises the steps of:

20 forming first and second pluralities of vias through the laminated
21 structure, each of the first plurality of vias passing through an isolation
22 aperture in each of the first and third metal layers, and each of the second
23 plurality of vias passing through the an isolation aperture in the second layer;
24 and

25 metallizing the interior surface of each of the vias.

26

27

28 31. The method of Claim 30, wherein the step of metallizing comprises

1 the steps of:

2 plating the interior via surfaces with a metal selected from the group
3 consisting of tin, nickel, and copper; and
4 coating the plated interior via surfaces with solder.

5

6 32. The method of Claim 30, further comprising, after the step of
7 forming the vias and before the step of metallizing, the step of forming an
8 isolation layer of insulative material on each of the external electrodes, each of
9 the isolation layers being configured so as to cover one of the external
10 electrodes and to leave exposed a portion of each metal area adjacent each of
11 the vias.

12

13 33. The method of Claim 32, wherein the isolation layers are formed of
14 glass-filled epoxy resin.

15

16 34. The method of Claim 32, wherein the step of metallizing is
17 performed so as to metallize the exposed portions of each metal area adjacent
18 each of the vias.

FIG. 1

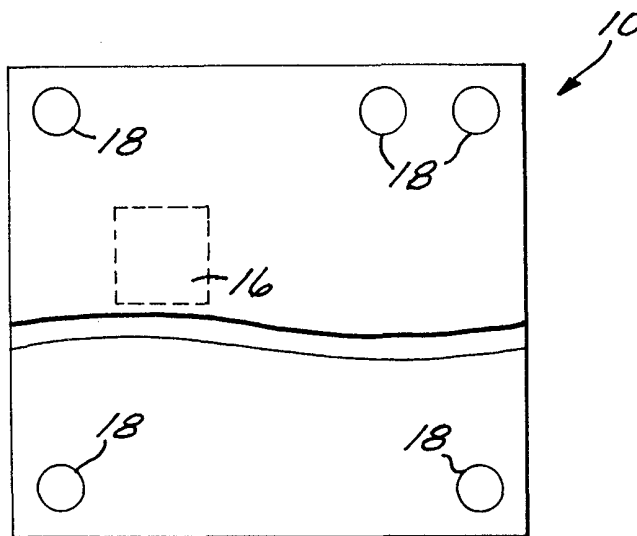

FIG. 2

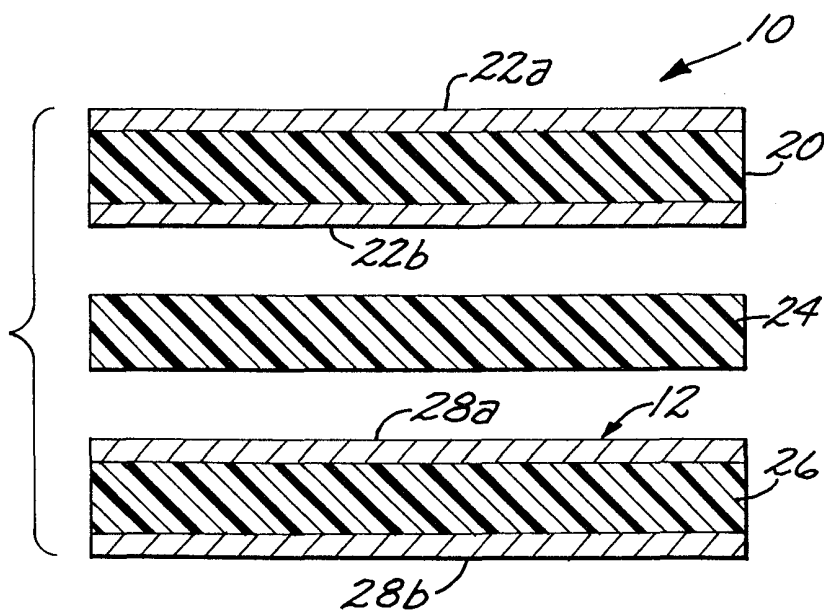

FIG. 3a

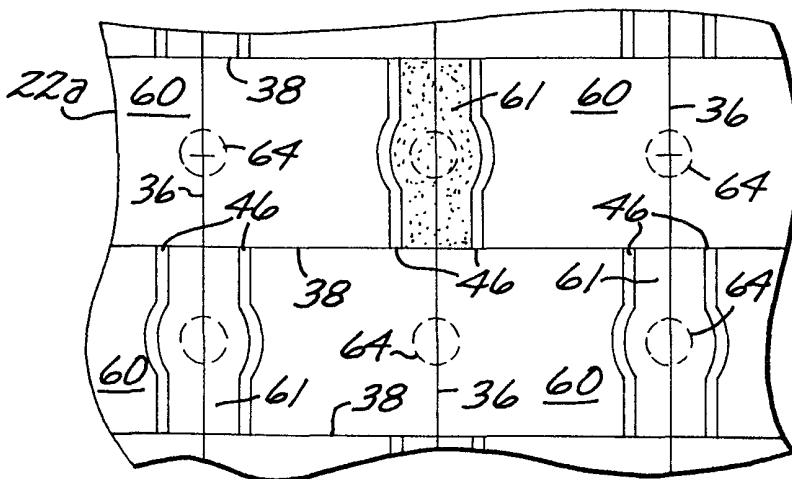

FIG. 3b

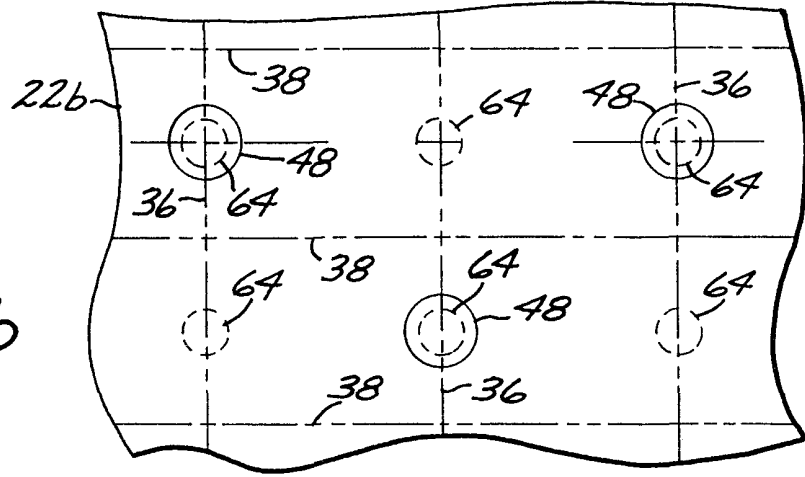

FIG. 3c

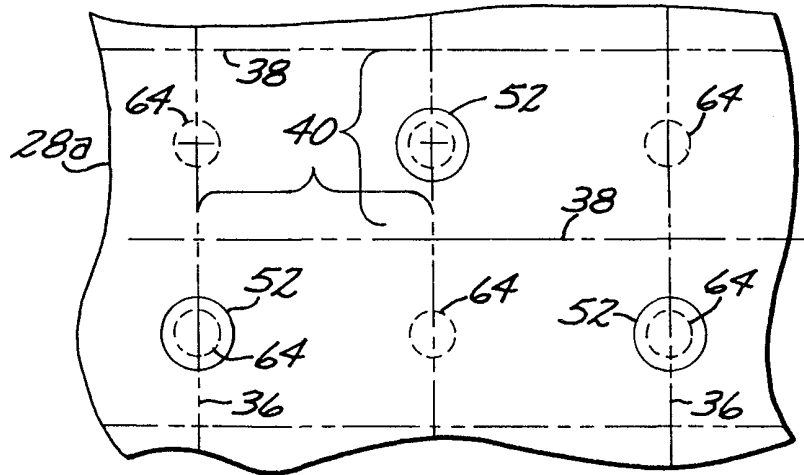
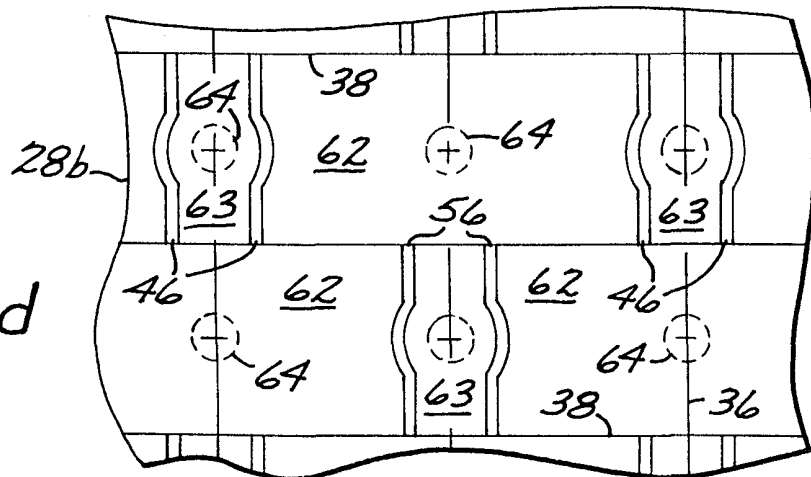

FIG. 3d



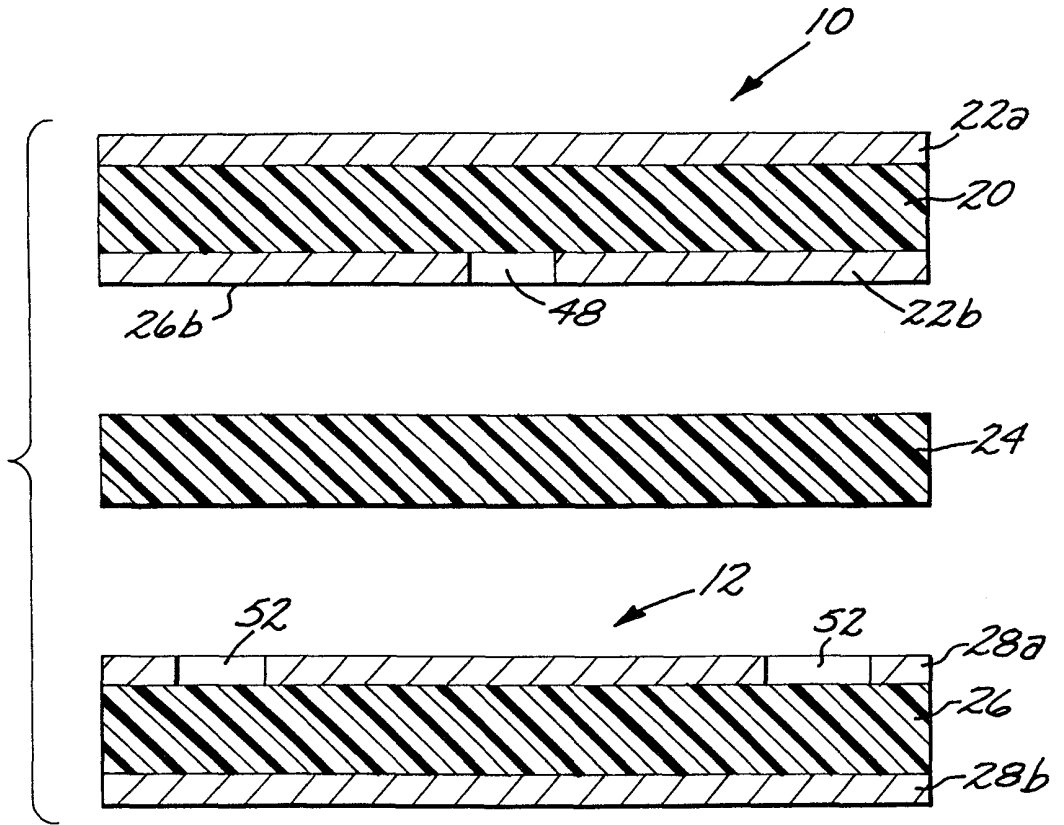

FIG. 4

4/13

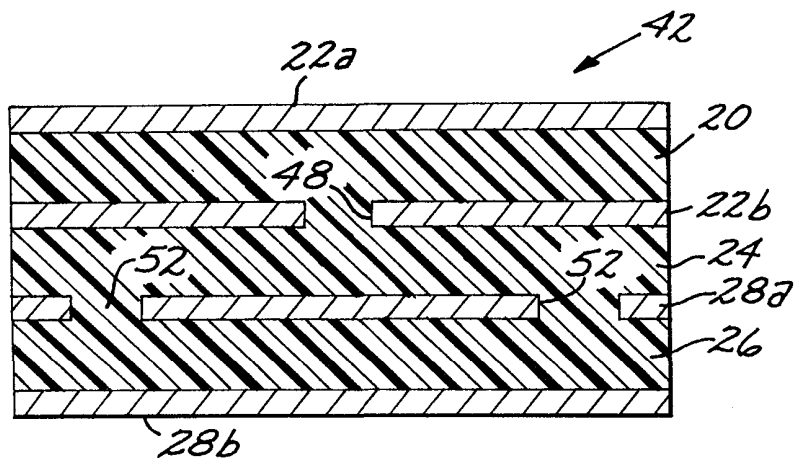

FIG. 5

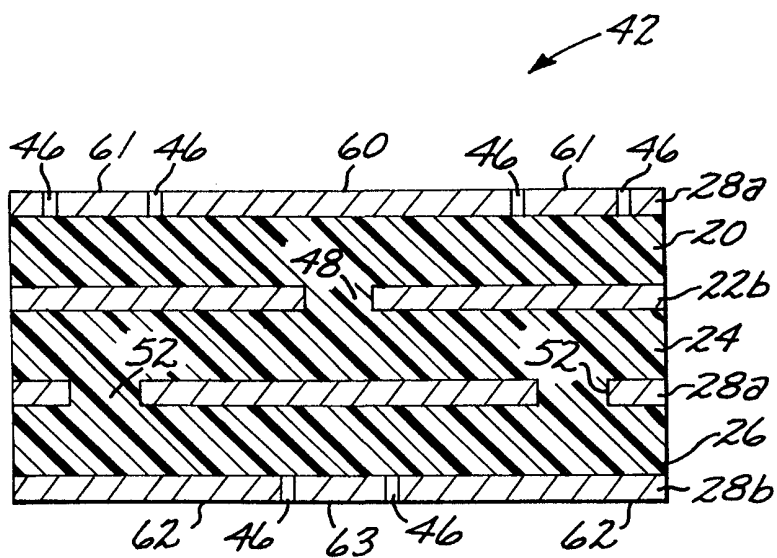

FIG. 6

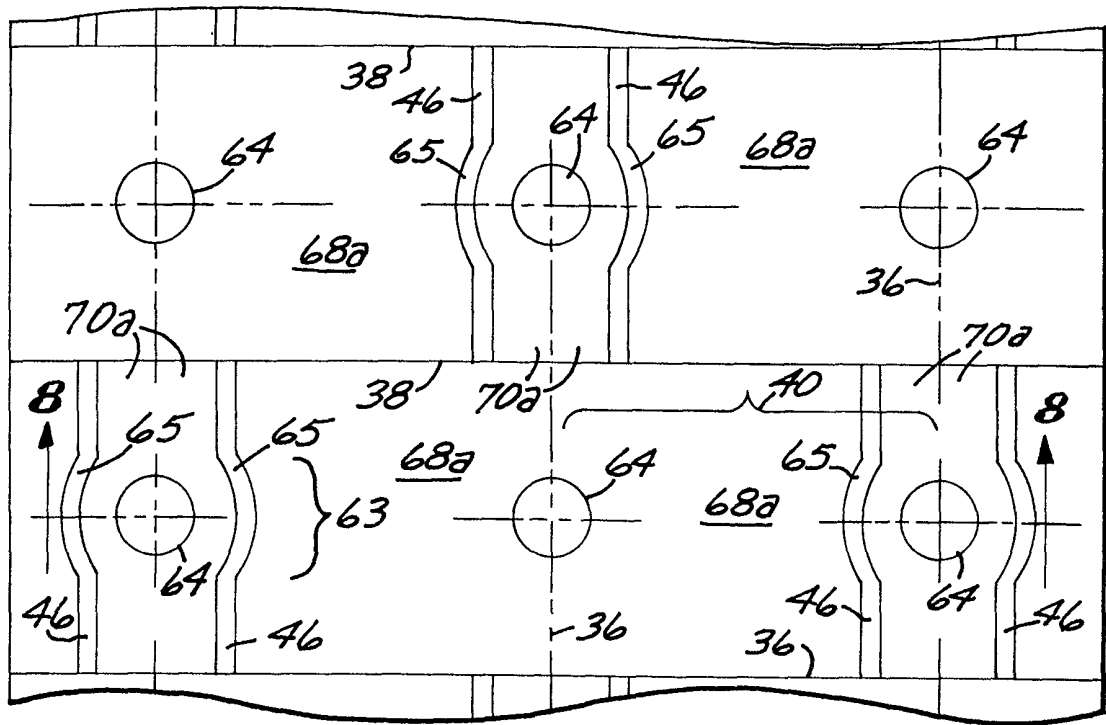

FIG. 7

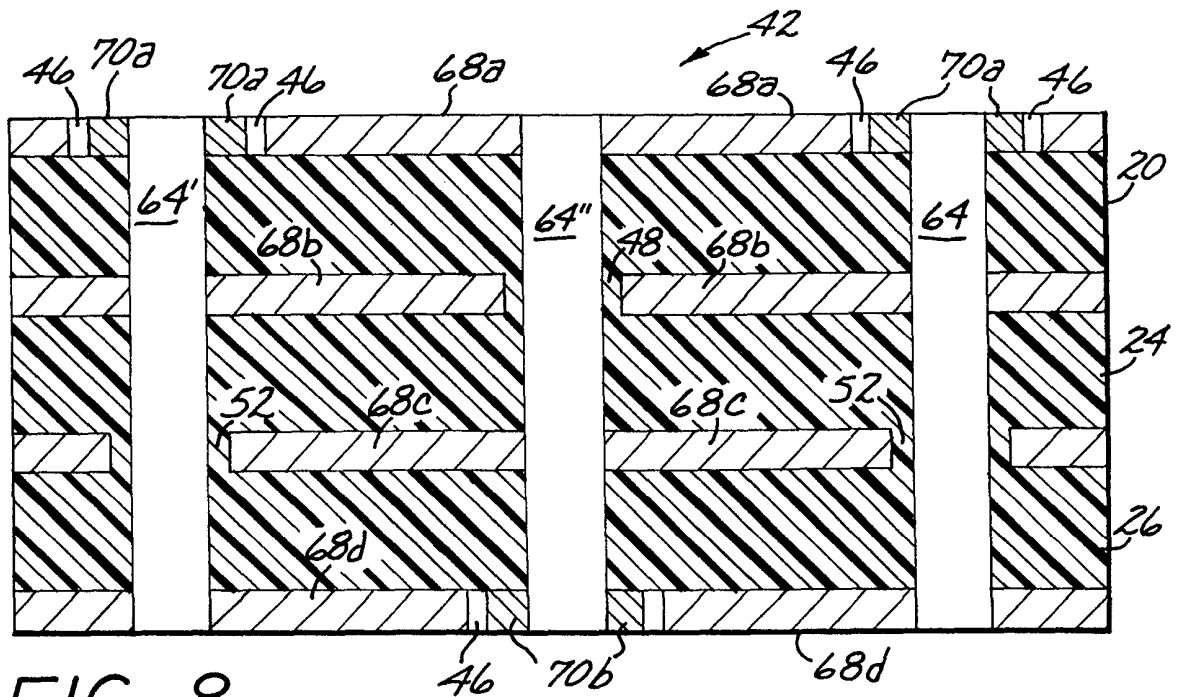

FIG. 8

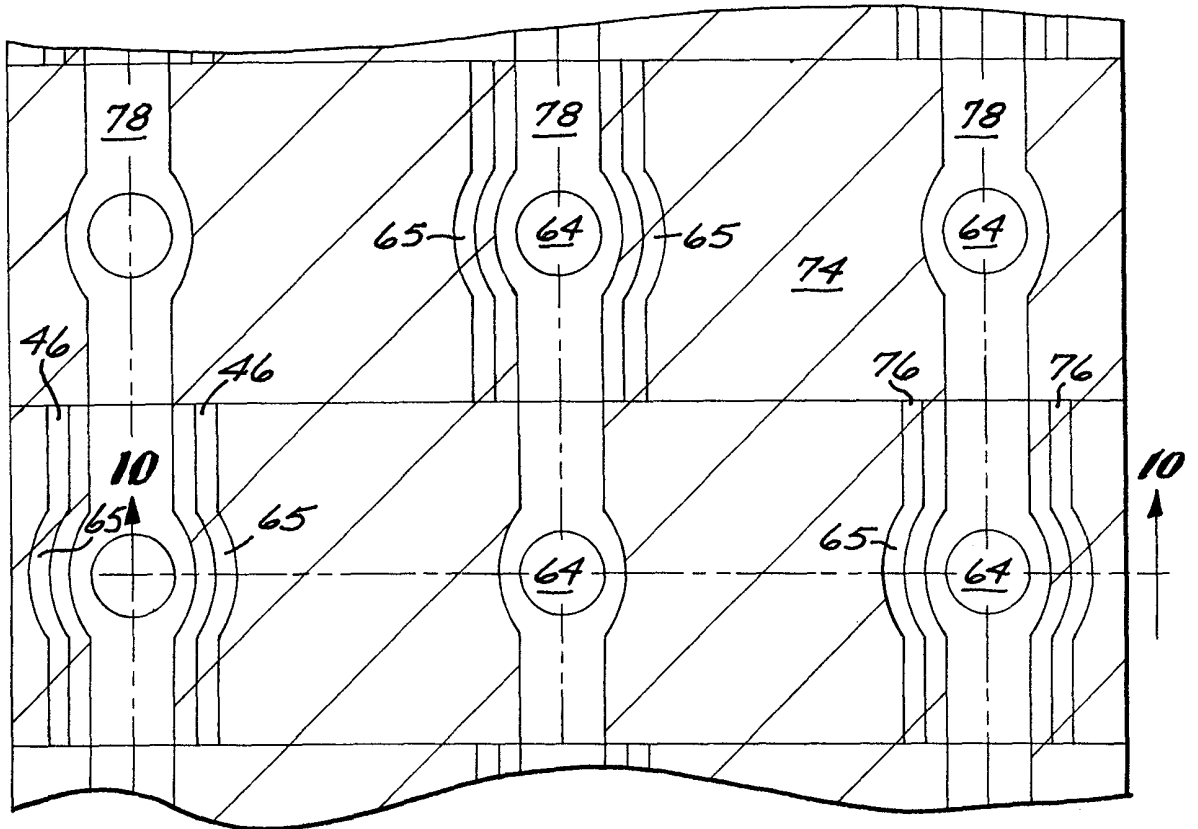

FIG. 9

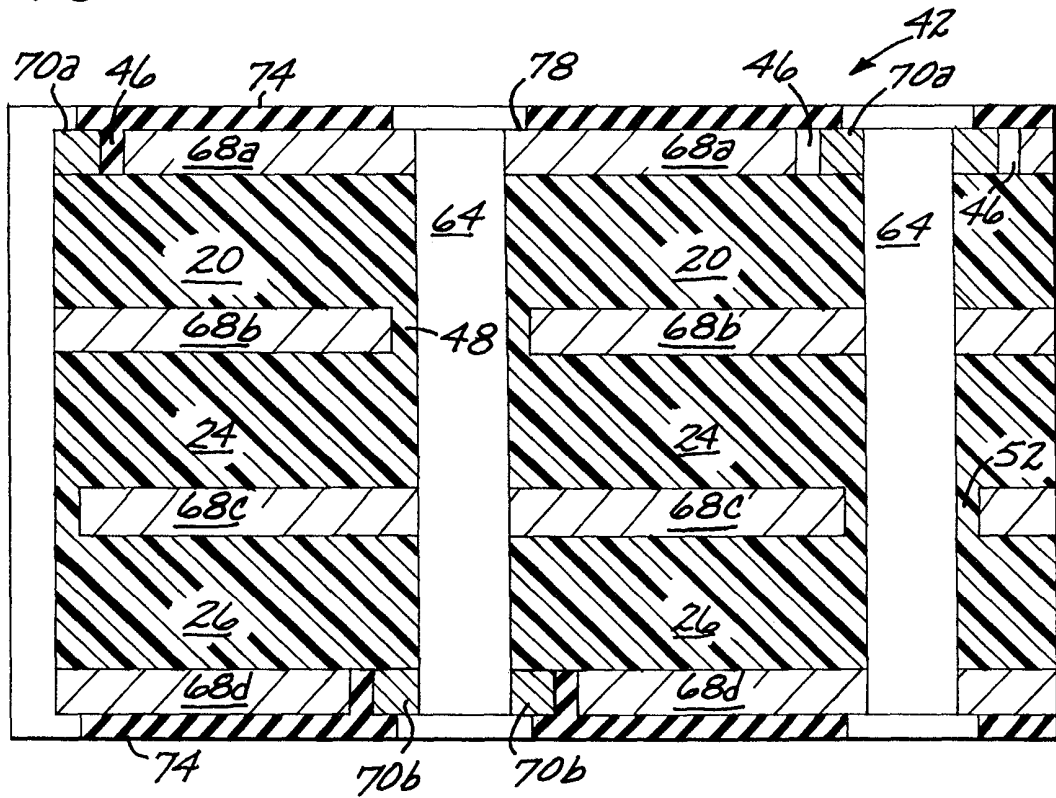

FIG. 10a

7/13

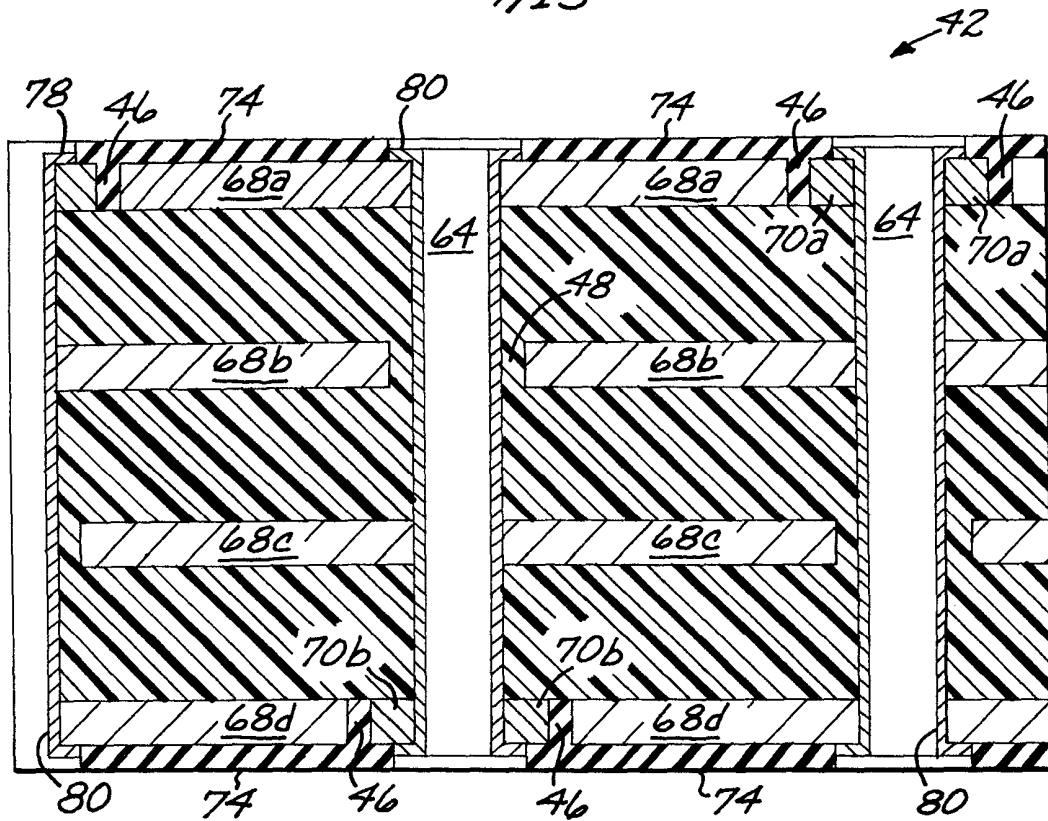

FIG. 10b

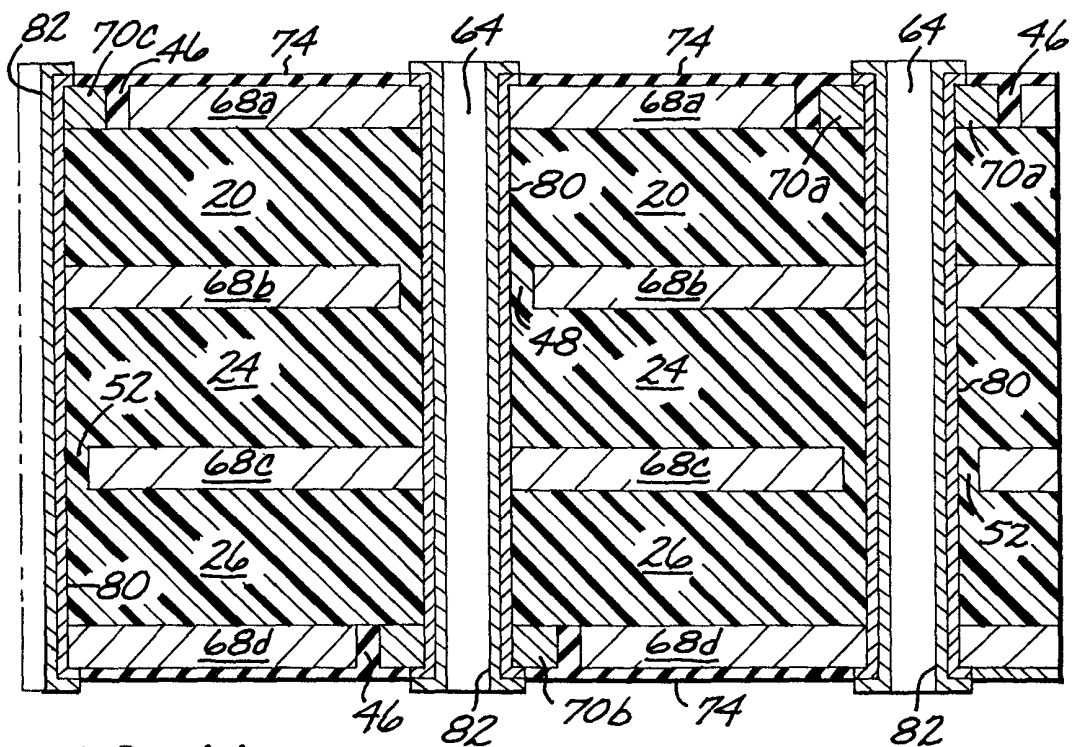

FIG. 11

8/13

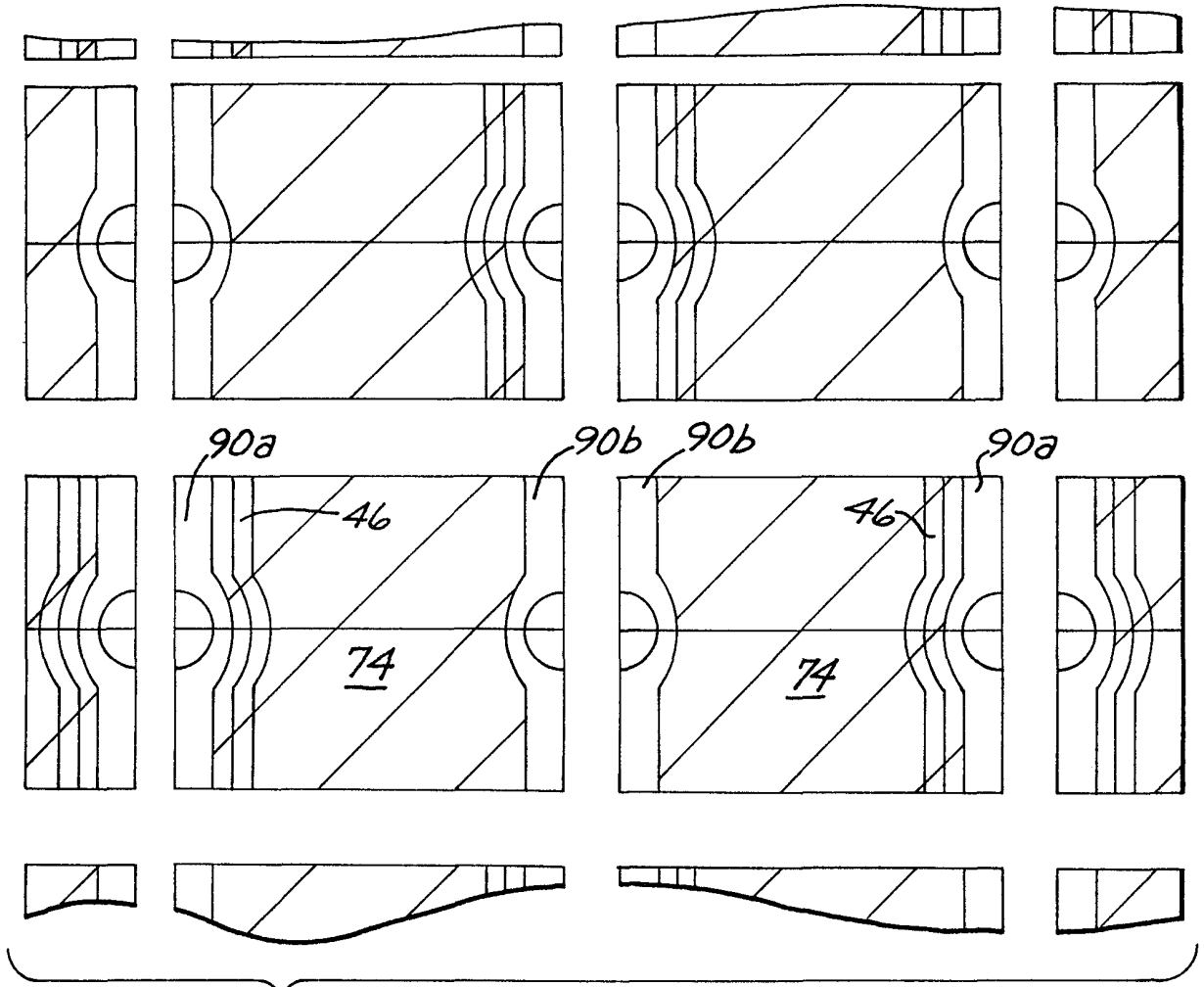

FIG. 12a

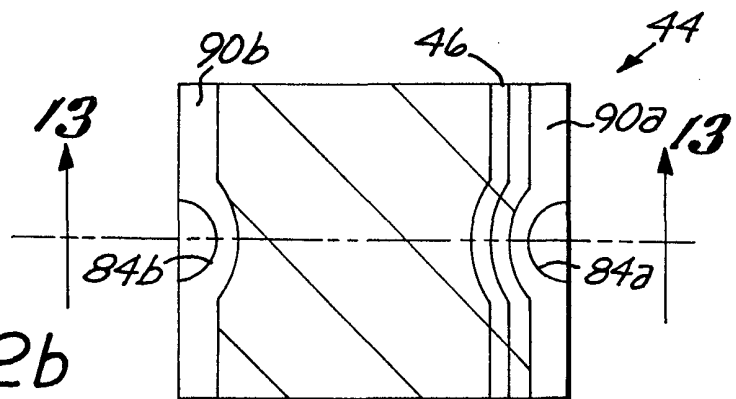

FIG. 12b

9/13

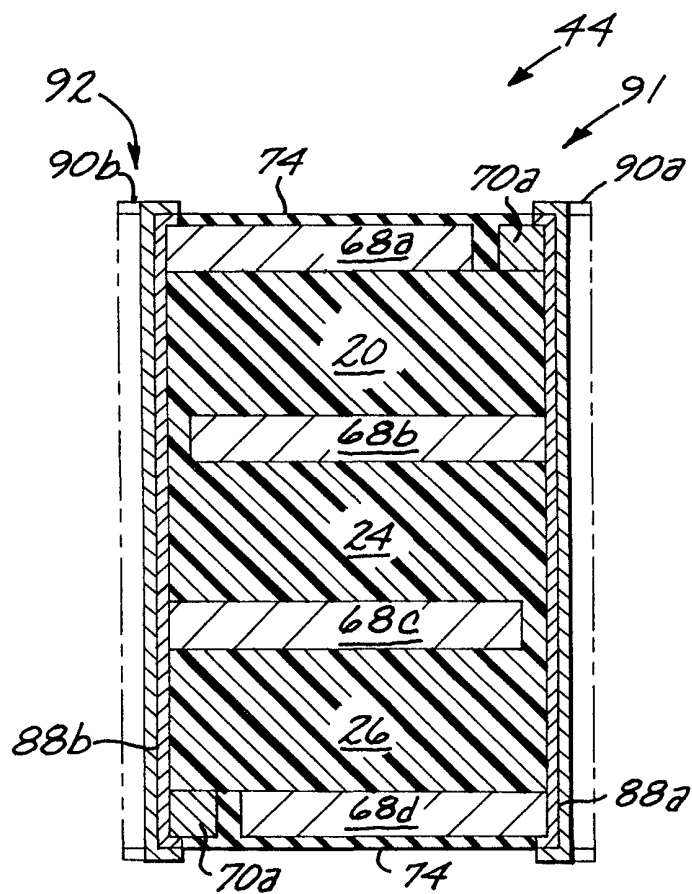

FIG. 13

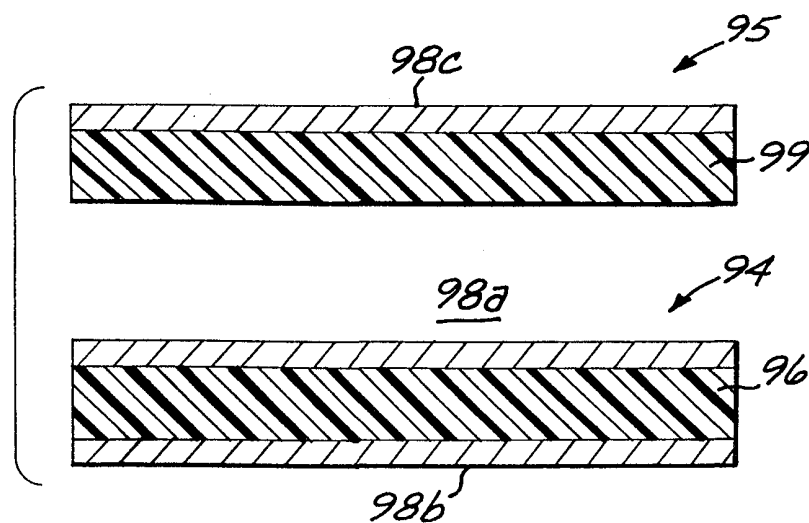

FIG. 14

10/13

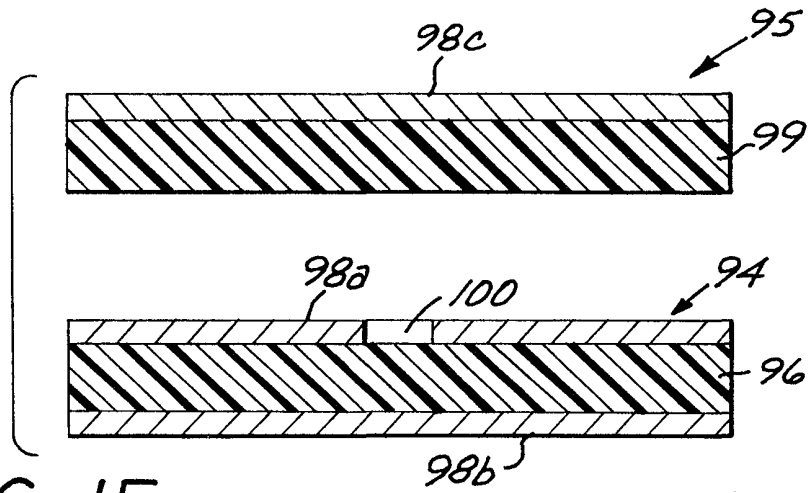

FIG. 15

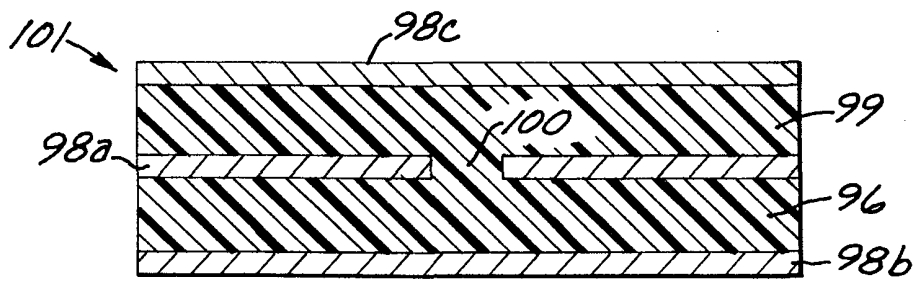

FIG. 16

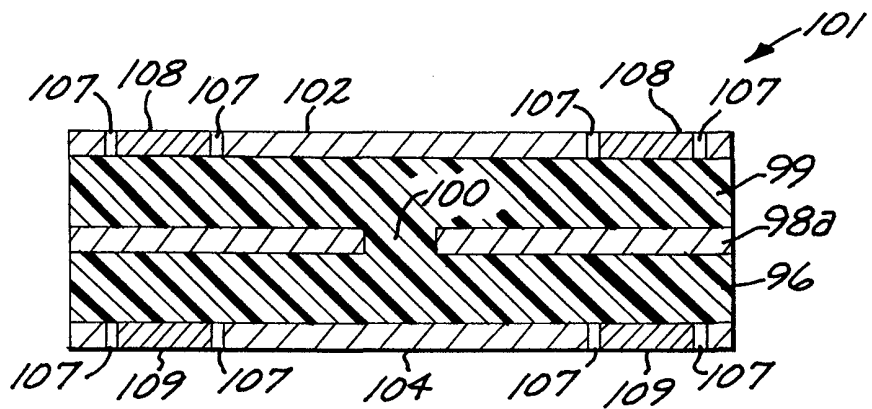

FIG. 17

11/13

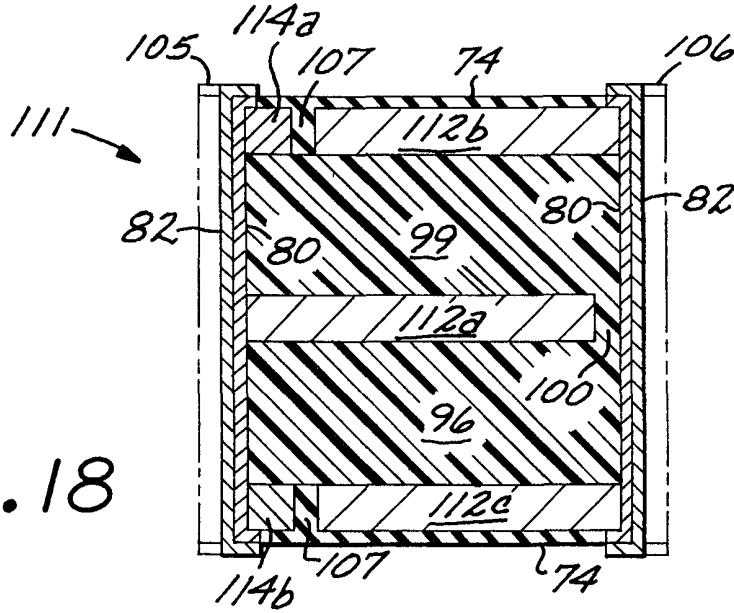

FIG. 18

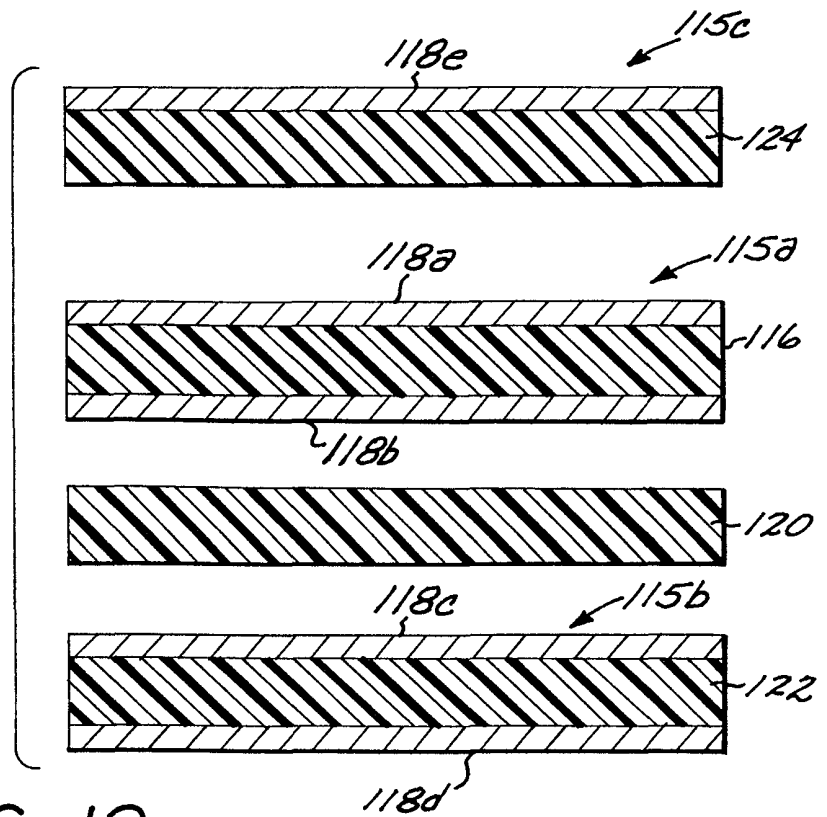

FIG. 19

12/13

FIG. 20

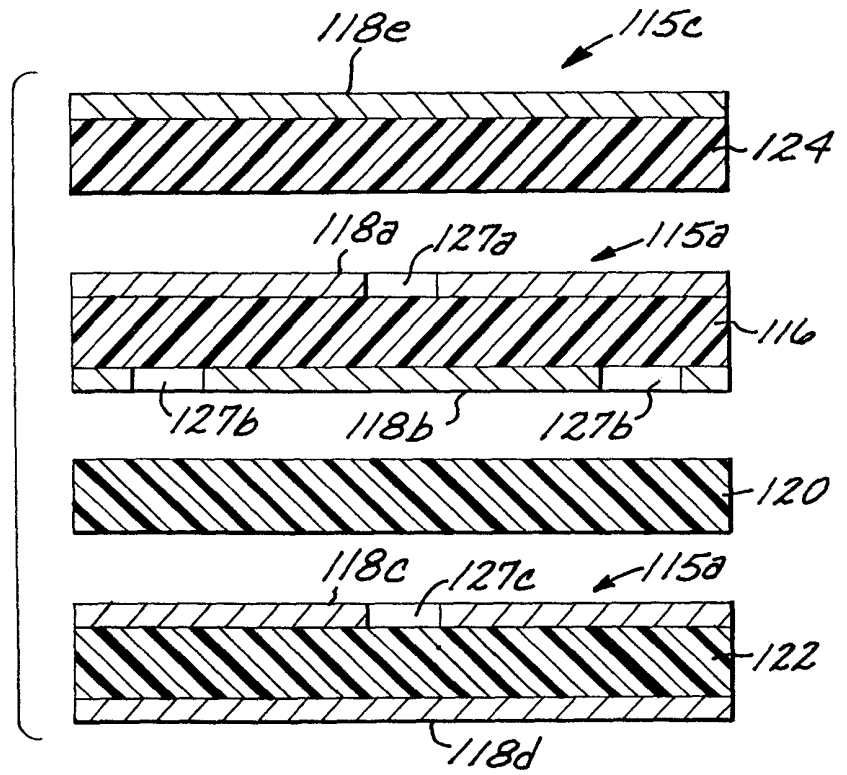
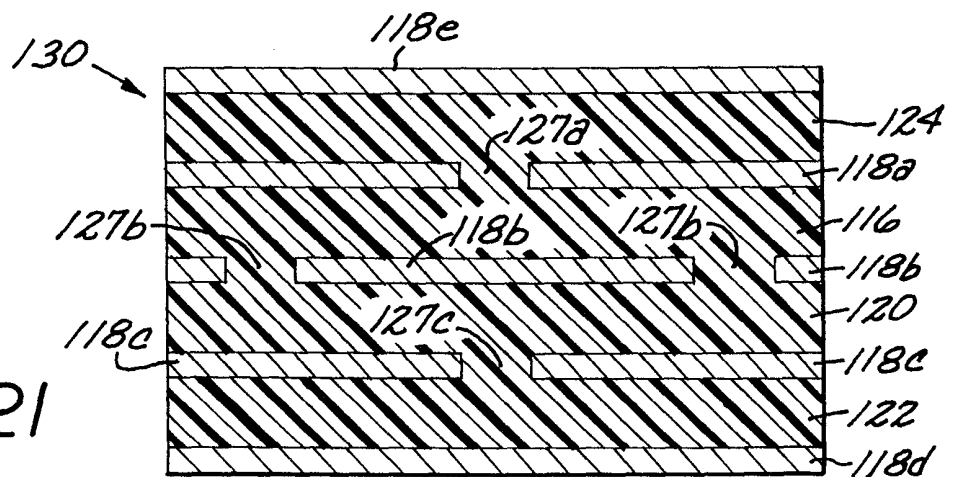
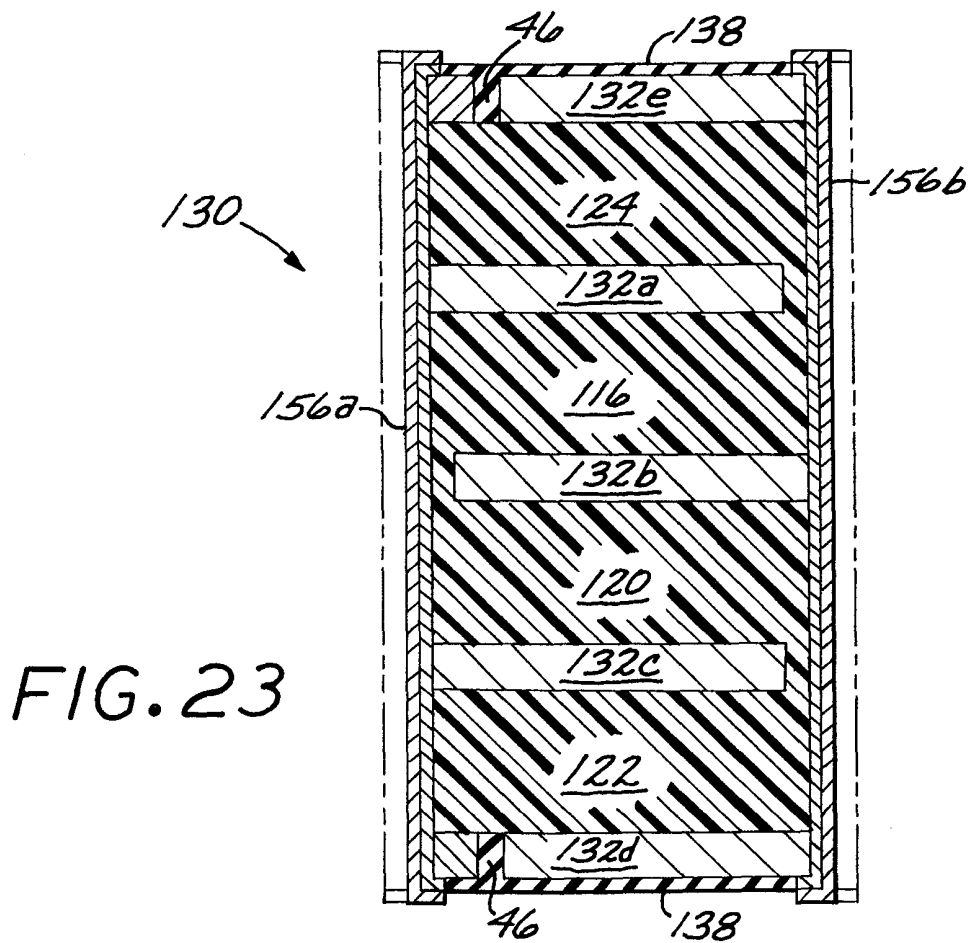
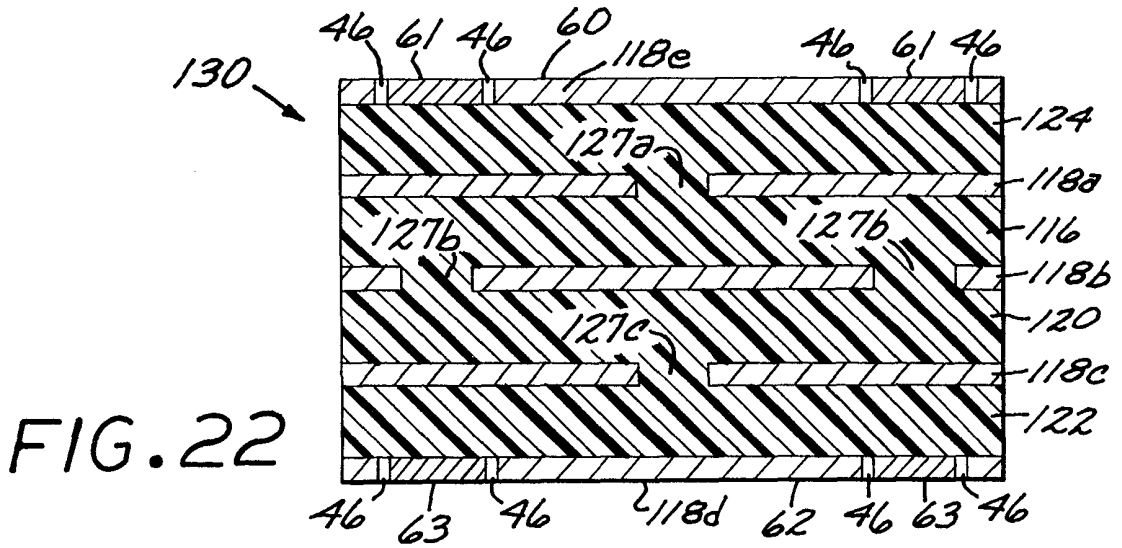

FIG. 21





INTERNATIONAL SEARCH REPORT

International Application No
PCT/US 99/25280

A. CLASSIFICATION OF SUBJECT MATTER IPC 7 H01C1/14 H01C17/28				
According to International Patent Classification (IPC) or to both national classification and IPC				
B. FIELDS SEARCHED				
Minimum documentation searched (classification system followed by classification symbols) IPC 7 H01C				
Documentation searched other than minimum documentation to the extent that such documents are included in the fields searched				
Electronic data base consulted during the international search (name of data base and, where practical, search terms used)				
C. DOCUMENTS CONSIDERED TO BE RELEVANT				
Category °	Citation of document, with indication, where appropriate, of the relevant passages	Relevant to claim No.		
X A X A	WO 98 29879 A (IKEDA TAKASHI ;KOJIMA JUNJI (JP); MATSUSHITA ELECTRIC IND CO LTD () 9 July 1998 (1998-07-09) English abstract and figures --- PATENT ABSTRACTS OF JAPAN vol. 1997, no. 07, 31 July 1997 (1997-07-31) & JP 09 069416 A (TDK CORP), 11 March 1997 (1997-03-11) abstract --- -/--	10-17, 20-24 1-9, 18, 19, 25-34 10-17, 20-24 1-9, 18, 19, 25-34		
<input checked="" type="checkbox"/> Further documents are listed in the continuation of box C.				
<input checked="" type="checkbox"/> Patent family members are listed in annex.				
° Special categories of cited documents :				
<table style="width: 100%; border: none;"> <tr> <td style="width: 50%; border: none; vertical-align: top;"> "A" document defining the general state of the art which is not considered to be of particular relevance "E" earlier document but published on or after the international filing date "L" document which may throw doubts on priority claim(s) or which is cited to establish the publication date of another citation or other special reason (as specified) "O" document referring to an oral disclosure, use, exhibition or other means "P" document published prior to the international filing date but later than the priority date claimed </td> <td style="width: 50%; border: none; vertical-align: top;"> "T" later document published after the international filing date or priority date and not in conflict with the application but cited to understand the principle or theory underlying the invention "X" document of particular relevance; the claimed invention cannot be considered novel or cannot be considered to involve an inventive step when the document is taken alone "Y" document of particular relevance; the claimed invention cannot be considered to involve an inventive step when the document is combined with one or more other such documents, such combination being obvious to a person skilled in the art. "&" document member of the same patent family </td> </tr> </table>			"A" document defining the general state of the art which is not considered to be of particular relevance "E" earlier document but published on or after the international filing date "L" document which may throw doubts on priority claim(s) or which is cited to establish the publication date of another citation or other special reason (as specified) "O" document referring to an oral disclosure, use, exhibition or other means "P" document published prior to the international filing date but later than the priority date claimed	"T" later document published after the international filing date or priority date and not in conflict with the application but cited to understand the principle or theory underlying the invention "X" document of particular relevance; the claimed invention cannot be considered novel or cannot be considered to involve an inventive step when the document is taken alone "Y" document of particular relevance; the claimed invention cannot be considered to involve an inventive step when the document is combined with one or more other such documents, such combination being obvious to a person skilled in the art. "&" document member of the same patent family
"A" document defining the general state of the art which is not considered to be of particular relevance "E" earlier document but published on or after the international filing date "L" document which may throw doubts on priority claim(s) or which is cited to establish the publication date of another citation or other special reason (as specified) "O" document referring to an oral disclosure, use, exhibition or other means "P" document published prior to the international filing date but later than the priority date claimed	"T" later document published after the international filing date or priority date and not in conflict with the application but cited to understand the principle or theory underlying the invention "X" document of particular relevance; the claimed invention cannot be considered novel or cannot be considered to involve an inventive step when the document is taken alone "Y" document of particular relevance; the claimed invention cannot be considered to involve an inventive step when the document is combined with one or more other such documents, such combination being obvious to a person skilled in the art. "&" document member of the same patent family			
Date of the actual completion of the international search <p style="text-align: center; font-weight: bold;">14 January 2000</p>	Date of mailing of the international search report <p style="text-align: center; font-weight: bold;">26/01/2000</p>			
Name and mailing address of the ISA European Patent Office, P.B. 5818 Patentlaan 2 NL - 2280 HV Rijswijk Tel. (+31-70) 340-2040, Tx. 31 651 epo nl, Fax: (+31-70) 340-3016	Authorized officer <p style="text-align: center; font-weight: bold;">Odgers, M</p>			

INTERNATIONAL SEARCH REPORT

Inter: nal Application No
PCT/US 99/25280

C.(Continuation) DOCUMENTS CONSIDERED TO BE RELEVANT		
Category	Citation of document, with indication, where appropriate, of the relevant passages	Relevant to claim No.
A	US 5 089 801 A (CHAN CHI-MING ET AL) 18 February 1992 (1992-02-18) cited in the application column 7, line 10-60 ---	1, 10, 16, 21, 24, 25, 27
A	US 4 769 901 A (NAGAHORI ATSUSHI) 13 September 1988 (1988-09-13) cited in the application column 3, line 4-26 column 4, line 30-35 ---	1, 5, 6, 10, 16, 21, 24, 25, 27, 30, 31
A	EP 0 853 323 A (RAYCHEM CORP) 15 July 1998 (1998-07-15) claims 1-4, 8, 10; figures 5, 6 -----	1, 5, 6, 10, 16, 21, 24, 25, 27, 30, 31

INTERNATIONAL SEARCH REPORT

Information on patent family members

International Application No

PCT/US 99/25280

Patent document cited in search report	A	Publication date	Patent family member(s)	Publication date
WO 9829879	A	09-07-1998	EP 0955643 A	10-11-1999
JP 09069416	A	11-03-1997	NONE	
US 5089801	A	18-02-1992	AT 147882 T	15-02-1997
			CA 2092807 A	29-03-1992
			DE 69124256 D	27-02-1997
			DE 69124256 T	14-08-1997
			EP 0551384 A	21-07-1993
			HK 1006888 A	19-03-1999
			JP 6501817 T	24-02-1994
			US 5436609 A	25-07-1995
			WO 9206477 A	16-04-1992
US 4769901	A	13-09-1988	JP 1972106 C	27-09-1995
			JP 6090962 B	14-11-1994
			JP 62230001 A	08-10-1987
			DE 3707493 A	01-10-1987
			US 4876439 A	24-10-1989
EP 0853323	A	15-07-1998	CA 2190361 A	23-11-1995
			CN 1148441 A	23-04-1997
			DE 69504333 D	01-10-1998
			DE 69504333 T	12-05-1999
			EP 0760157 A	05-03-1997
			JP 10500255 T	06-01-1998
			WO 9531816 A	23-11-1995
			US 5831510 A	03-11-1998