



US006343731B1

(12) **United States Patent**  
**Adams et al.**

(10) **Patent No.:** **US 6,343,731 B1**  
(45) **Date of Patent:** **Feb. 5, 2002**

(54) **METHOD AND DEVICE FOR FULL THICKNESS RESECTIONING OF AN ORGAN**

(75) Inventors: **Ronald D. Adams**, Holliston; **Roy H. Sullivan, III**, Millville, both of MA (US); **Lauren O. Main**, Somerset, MI (US); **Peter K. Kratsch**, Sunrise, FL (US); **George A. Nunez**, Miami, FL (US); **Jurgen A. Kortenbach**, Miami Springs, FL (US); **Matthew S. Solar**, Cooper City, FL (US); **Gerhard F. Buess**, Tübingen-Bebenhausen; **Marc O. Schurr**, Tübingen, both of (DE)

(73) Assignee: **Scimed Life Systems, Inc.**, Maple Grove, MN (US)

(\*) Notice: Subject to any disclaimer, the term of this patent is extended or adjusted under 35 U.S.C. 154(b) by 0 days.

(21) Appl. No.: **09/813,944**

(22) Filed: **Mar. 22, 2001**

**Related U.S. Application Data**

(63) Continuation of application No. 09/694,894, filed on Oct. 25, 2000.

(51) **Int. Cl.<sup>7</sup>** ..... **A61B 17/068**

(52) **U.S. Cl.** ..... **227/180.1; 227/19; 227/176.1; 227/179.1; 606/219**

(58) **Field of Search** ..... **227/19, 175.1, 227/176.1, 179.1, 180.1; 606/153, 219; 600/139, 140, 119**

(56) **References Cited**

**U.S. PATENT DOCUMENTS**

5,522,534 A \* 6/1996 Viola et al.

5,533,661 A \* 7/1996 Main et al.  
5,571,116 A \* 11/1996 Bolanos et al.  
5,609,285 A \* 3/1997 Grant et al.  
5,749,893 A \* 5/1998 Vidal et al.  
5,868,760 A \* 2/1999 McGuckin et al.  
5,897,562 A \* 4/1999 Bolanos et al.  
5,972,023 A \* 10/1999 Tanner et al.  
6,119,913 A \* 9/2000 Adams et al.

\* cited by examiner

*Primary Examiner*—Scott A. Smith

(74) *Attorney, Agent, or Firm*—Fay Kaplun & Marcin LLP

(57) **ABSTRACT**

A full-thickness resection system comprises a flexible endoscope and a stapling mechanism, wherein the endoscope is slidably received through at least a portion of the stapling mechanism. The stapling mechanism comprises an anvil and a stapling head mounted to the anvil so that the anvil and the stapling head are moveable with respect to one another between a tissue receiving position and a stapling position and wherein a gap formed between the stapling head and the anvil is larger in the tissue receiving position than it is in the stapling position. A position adjusting mechanism is provided for moving the anvil and the stapling head between the tissue receiving and stapling positions and a staple firing mechanism sequentially fires a plurality of staples from the stapling head across the gap against the anvil and through any tissue received in the gap and a knife cuts a portion of tissue received within the gap. A control unit which remains outside the body is coupled to the stapling mechanism for controlling operation of the position adjusting mechanism and the staple firing mechanism.

**31 Claims, 29 Drawing Sheets**

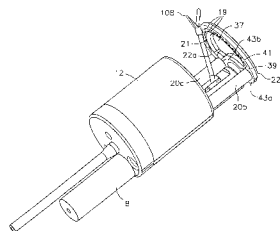
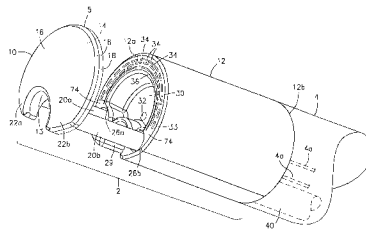

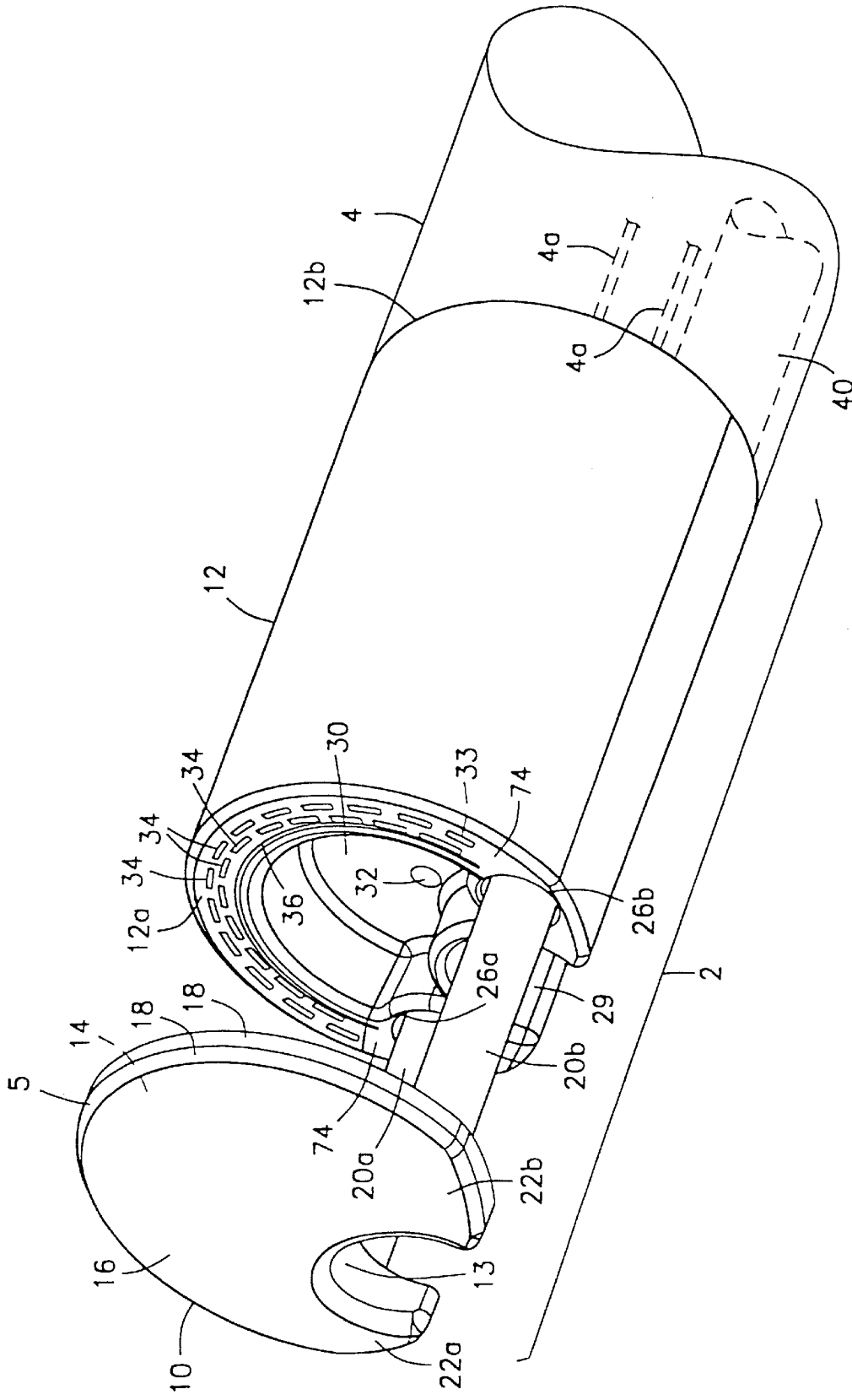

Fig. 1

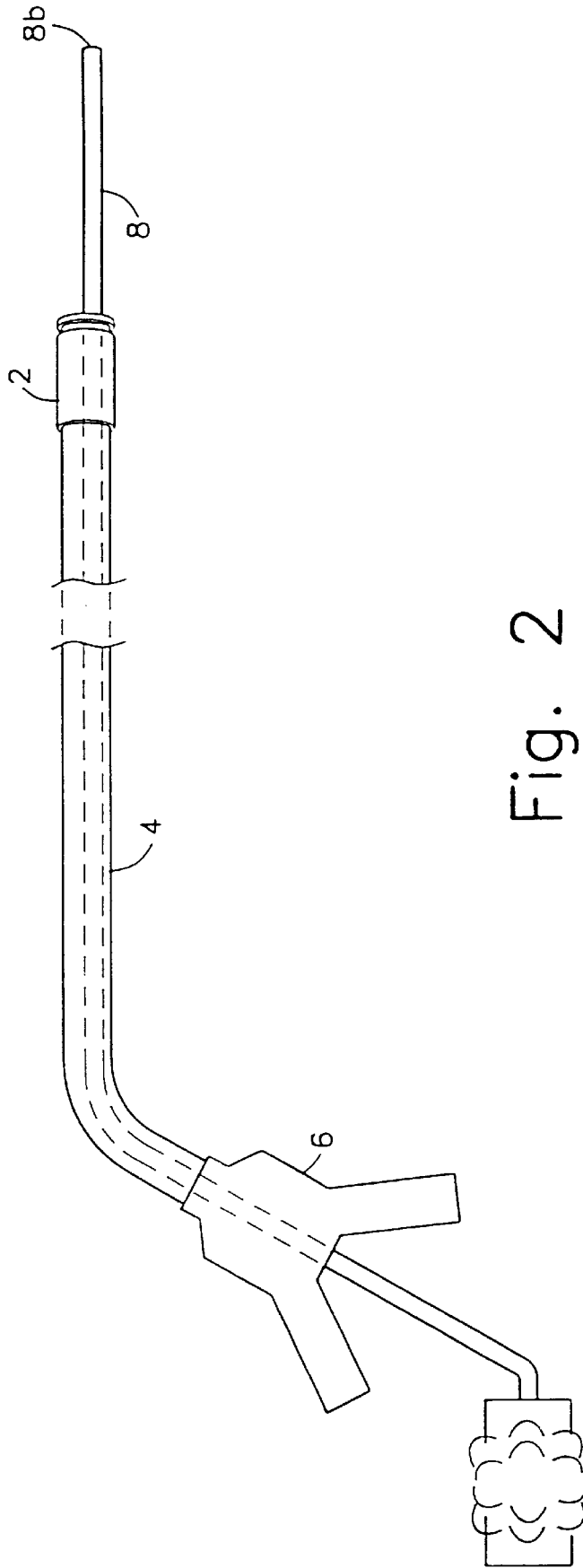

Fig. 2

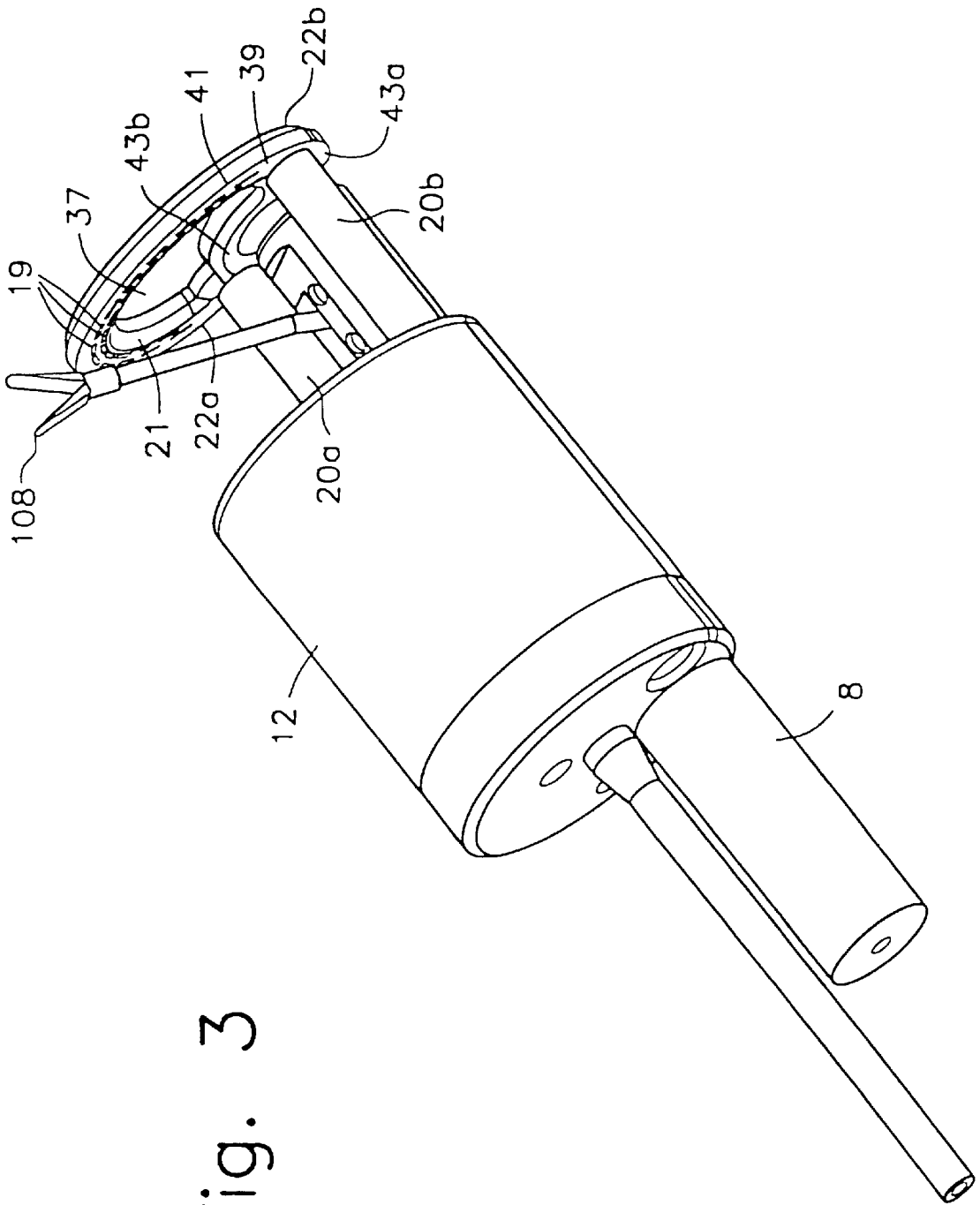

Fig. 3

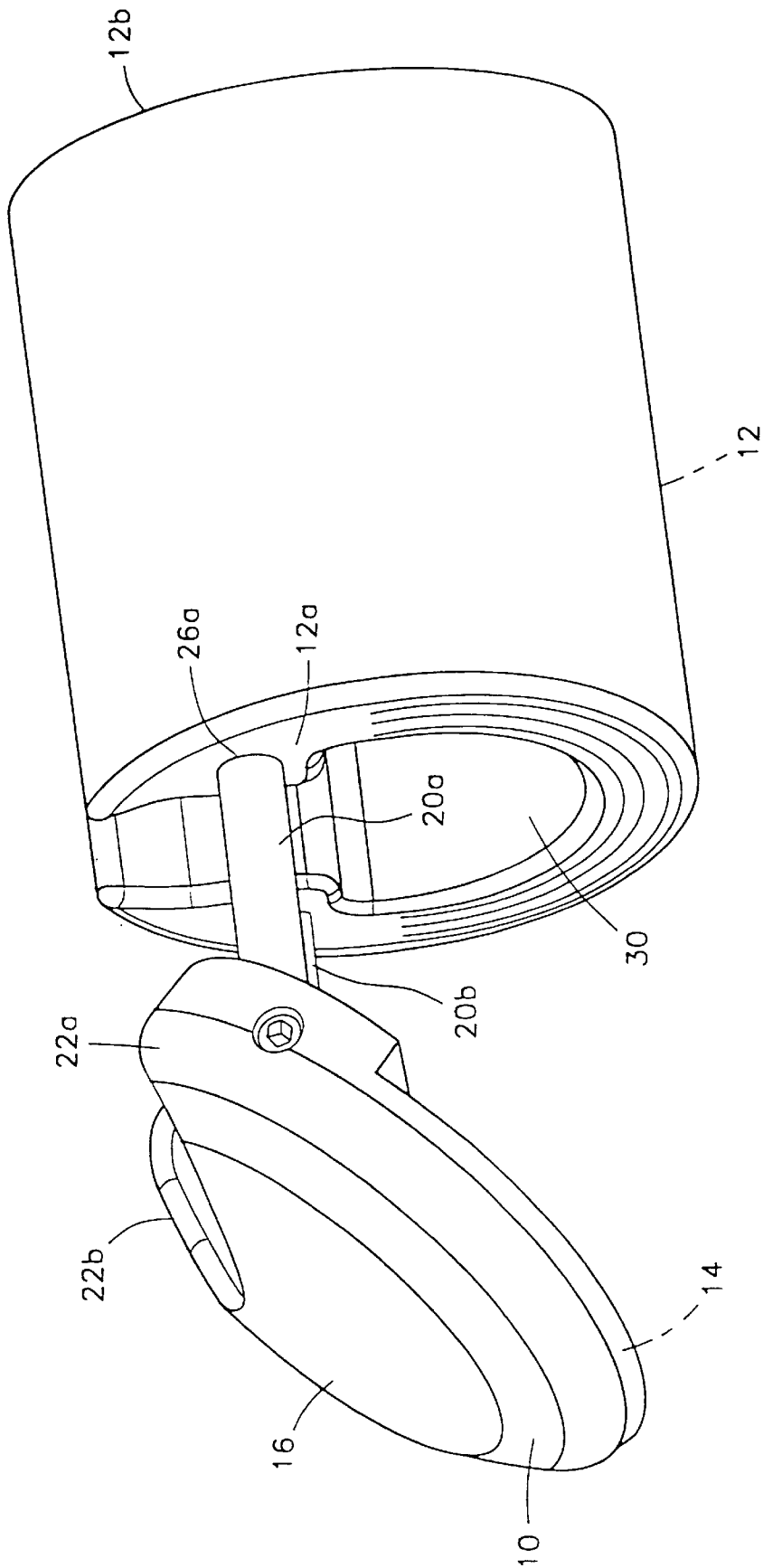

Fig. 3a

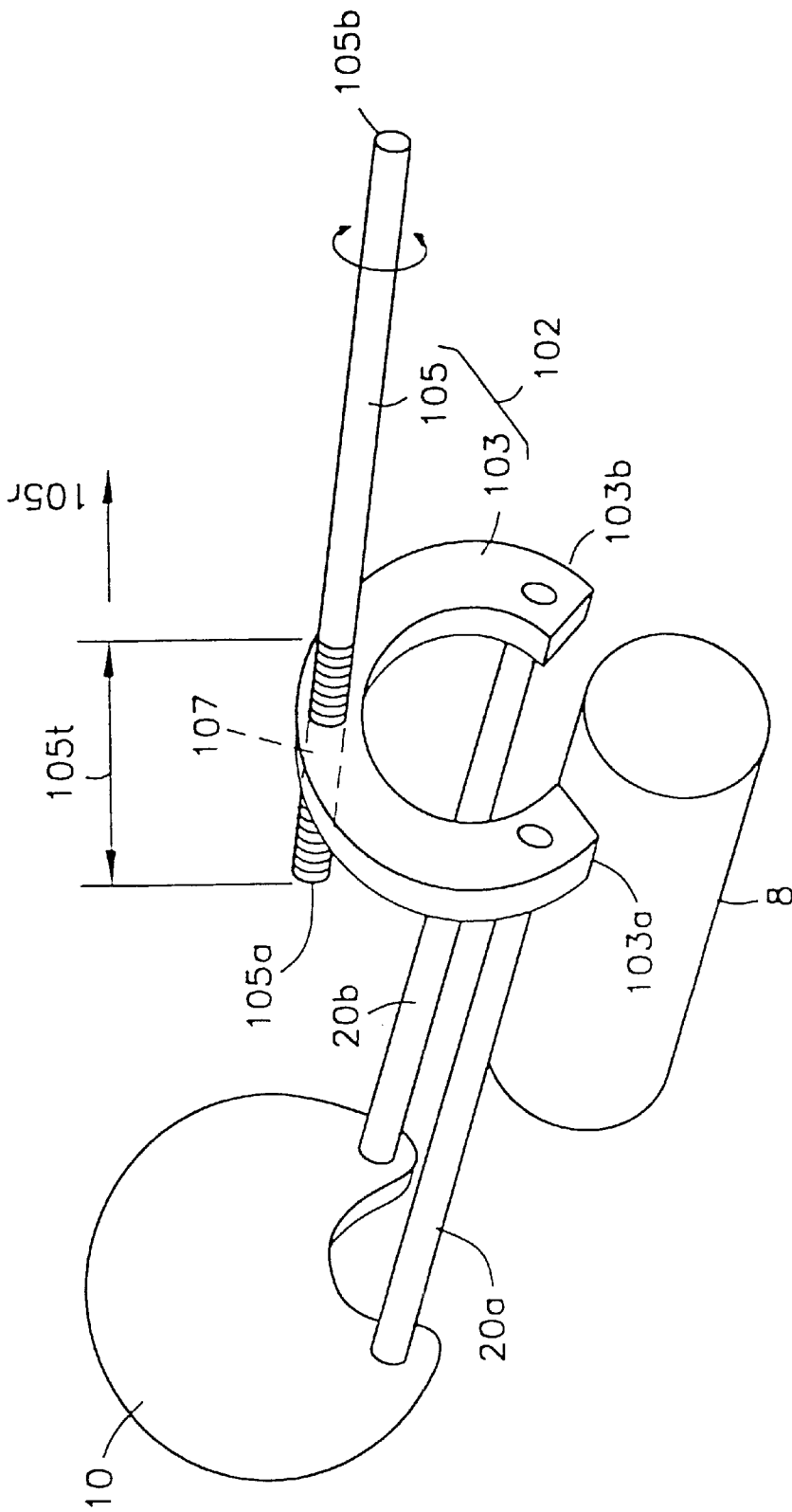

Fig. 4

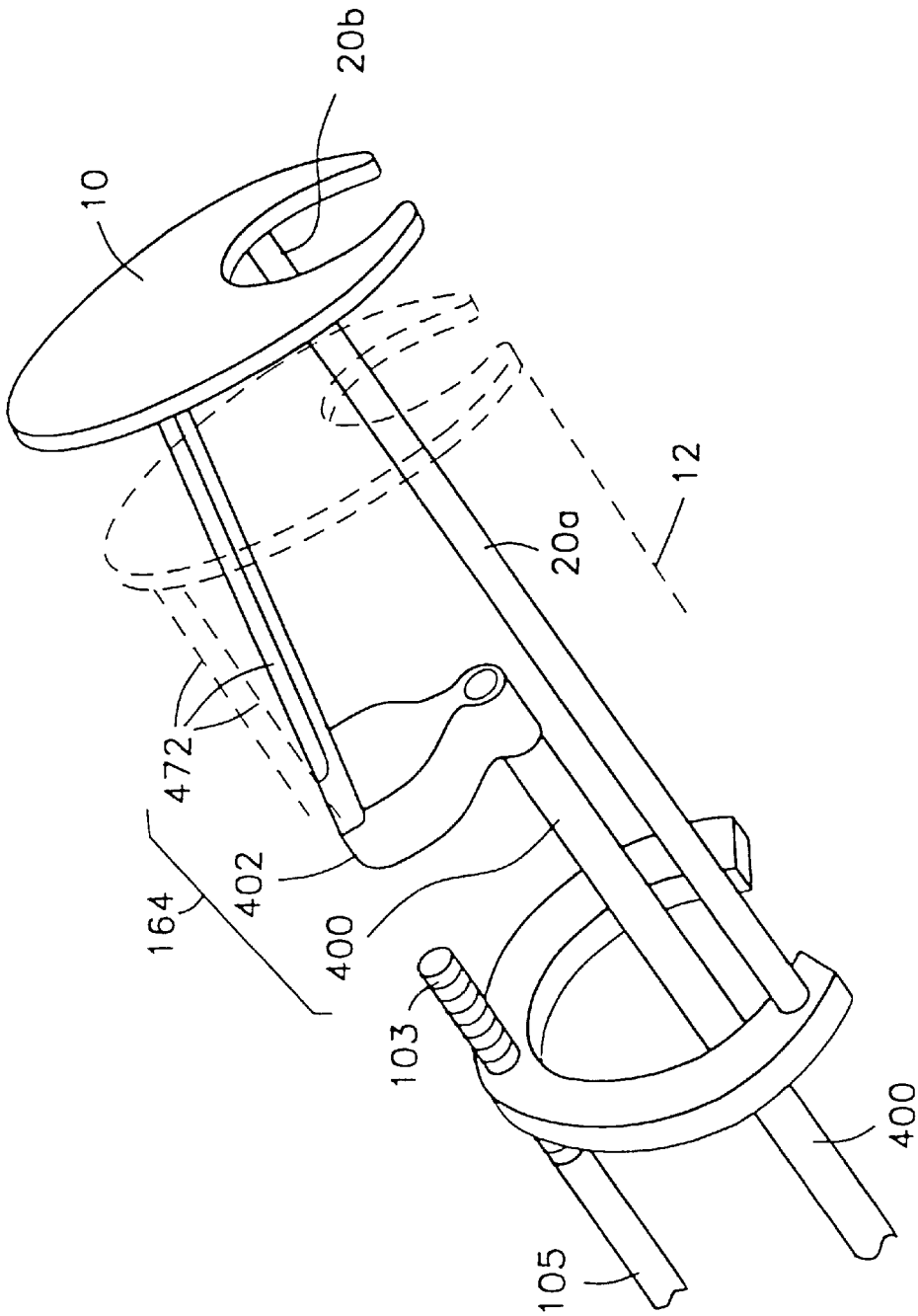

Fig. 5

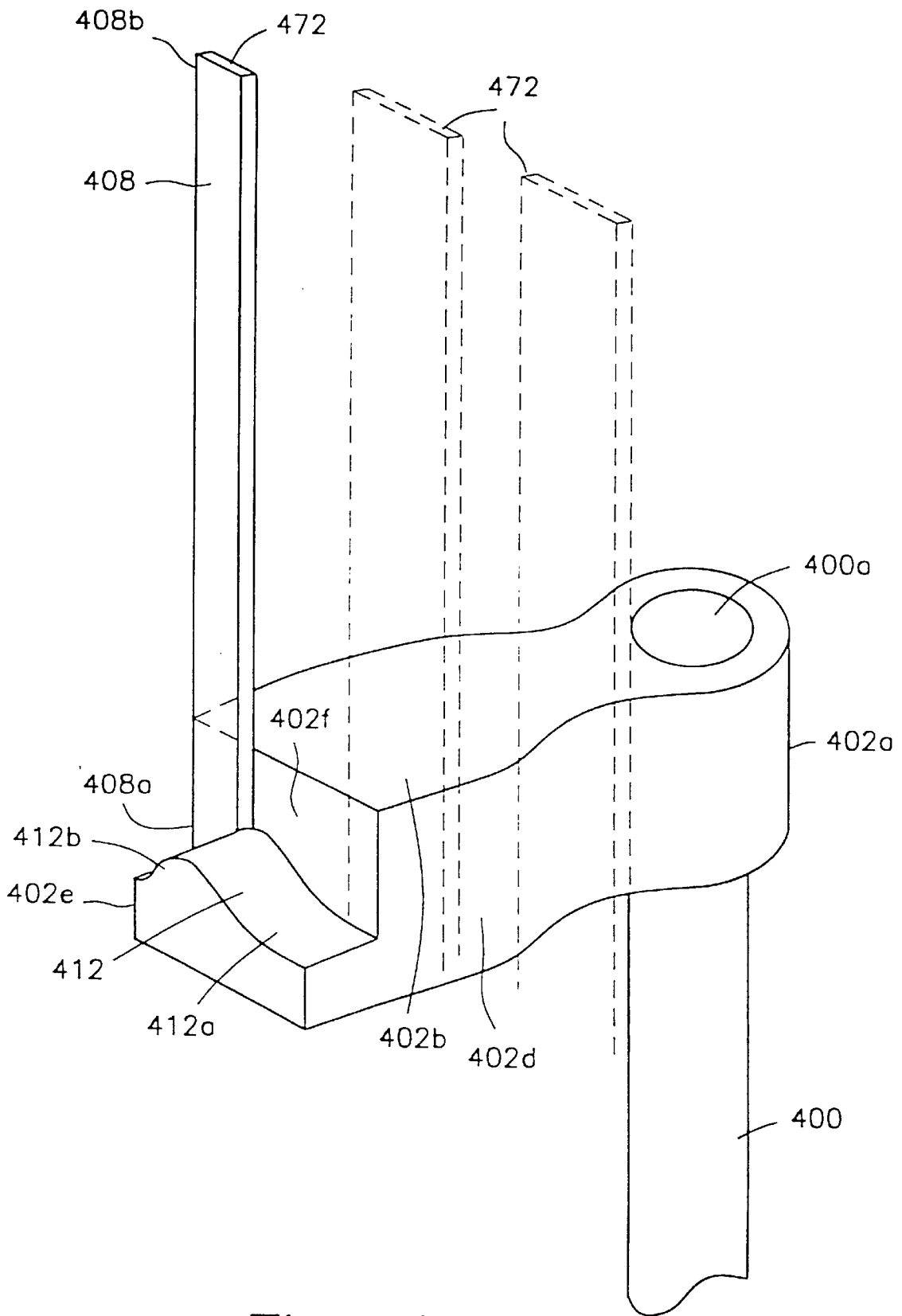

Fig. 6

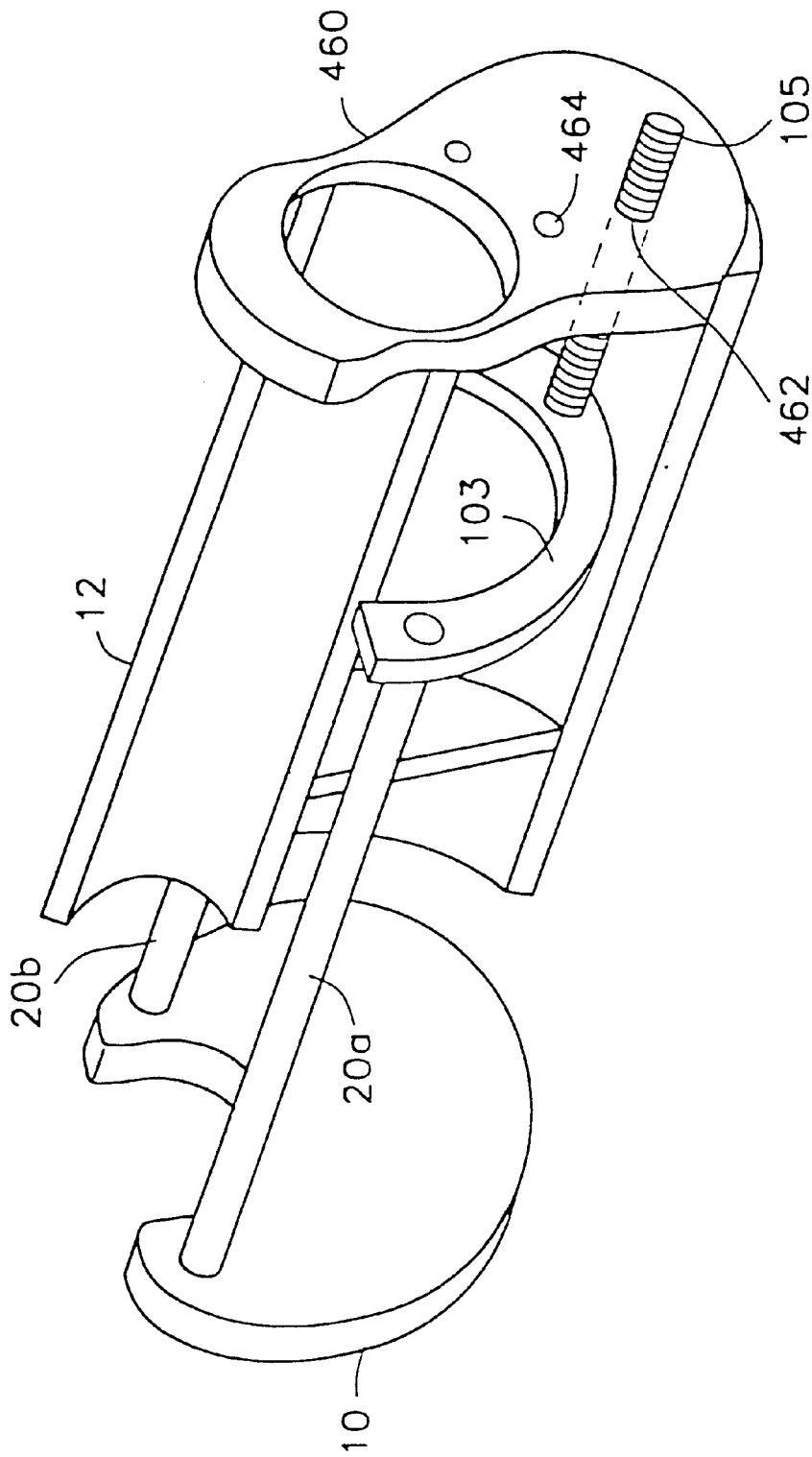

Fig. 7

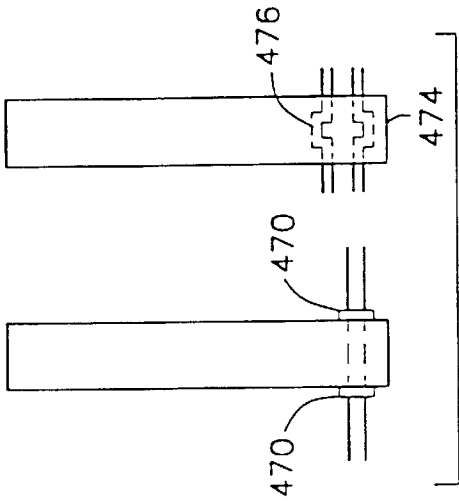

Fig. 9a

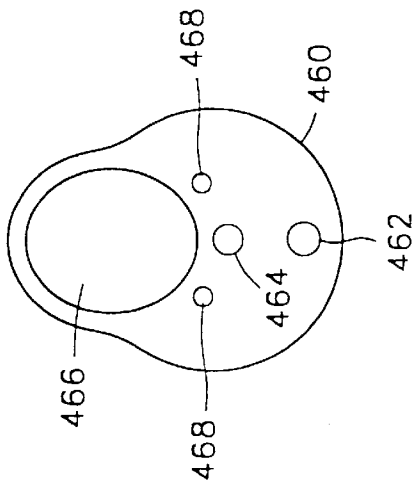

Fig. 8

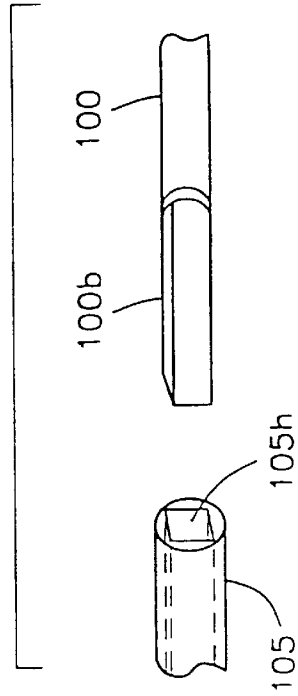

Fig. 9c

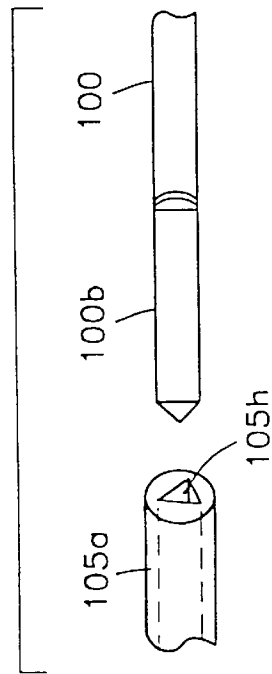

Fig. 9b

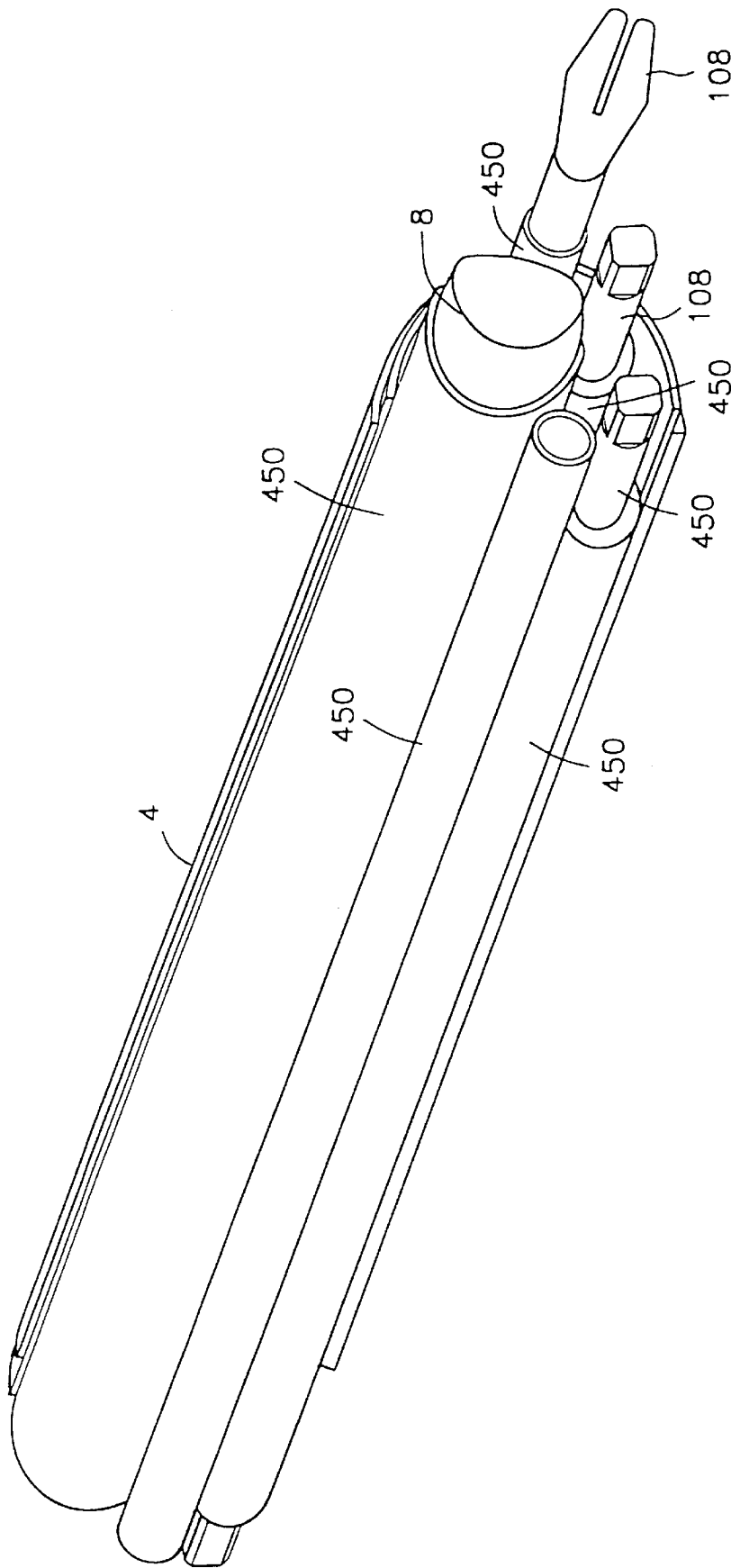
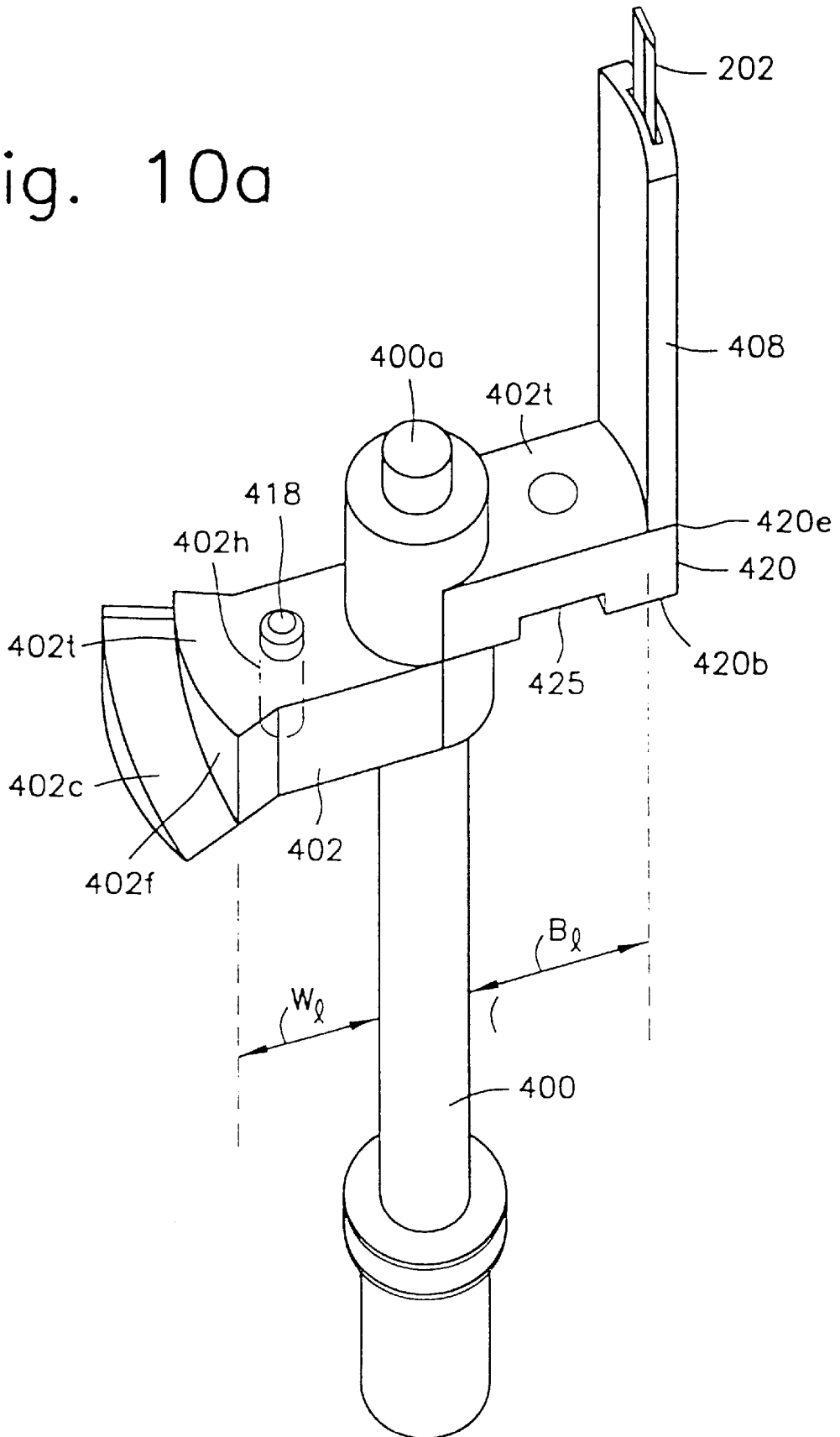

Fig. 9d

Fig. 10a



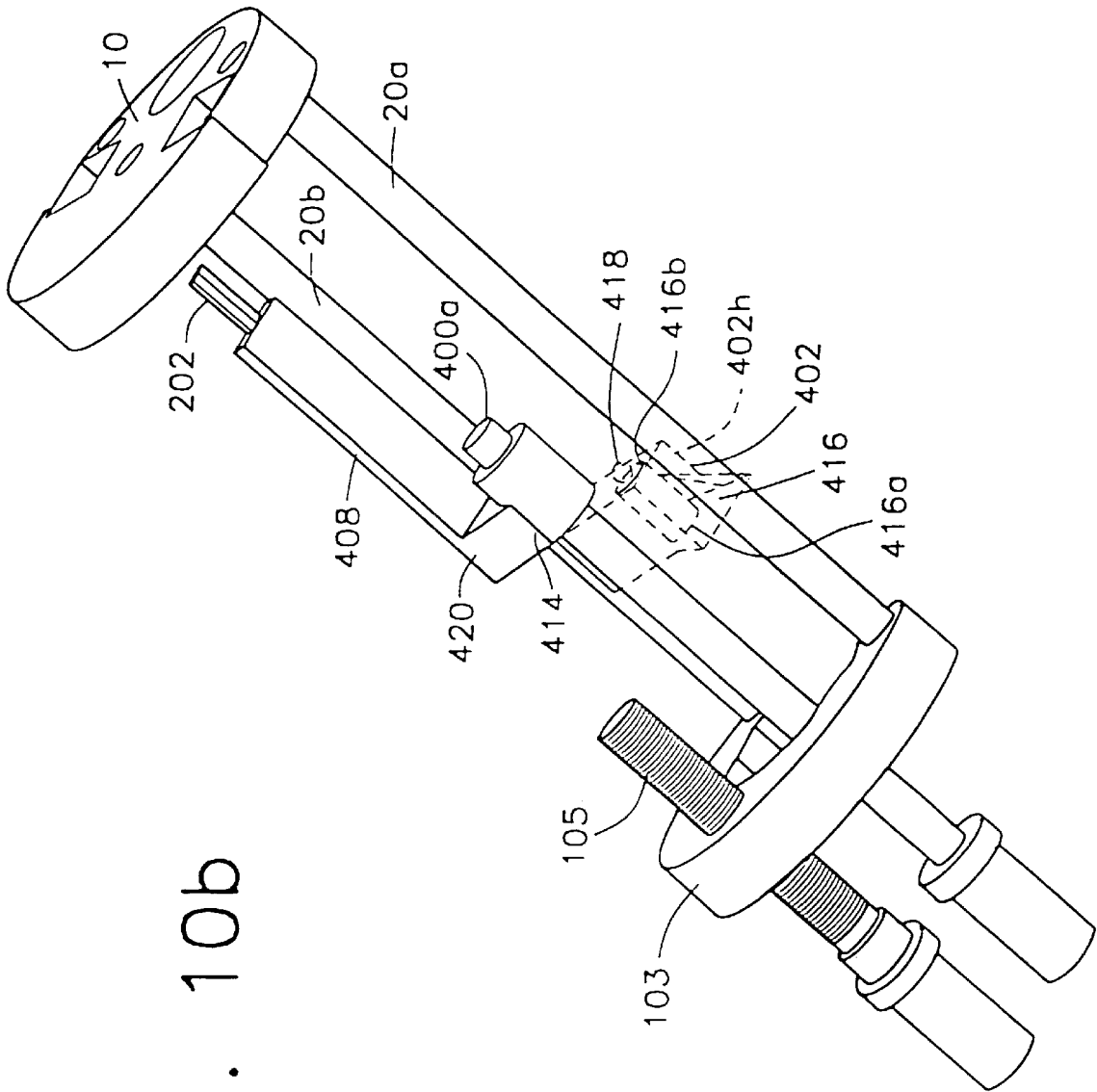
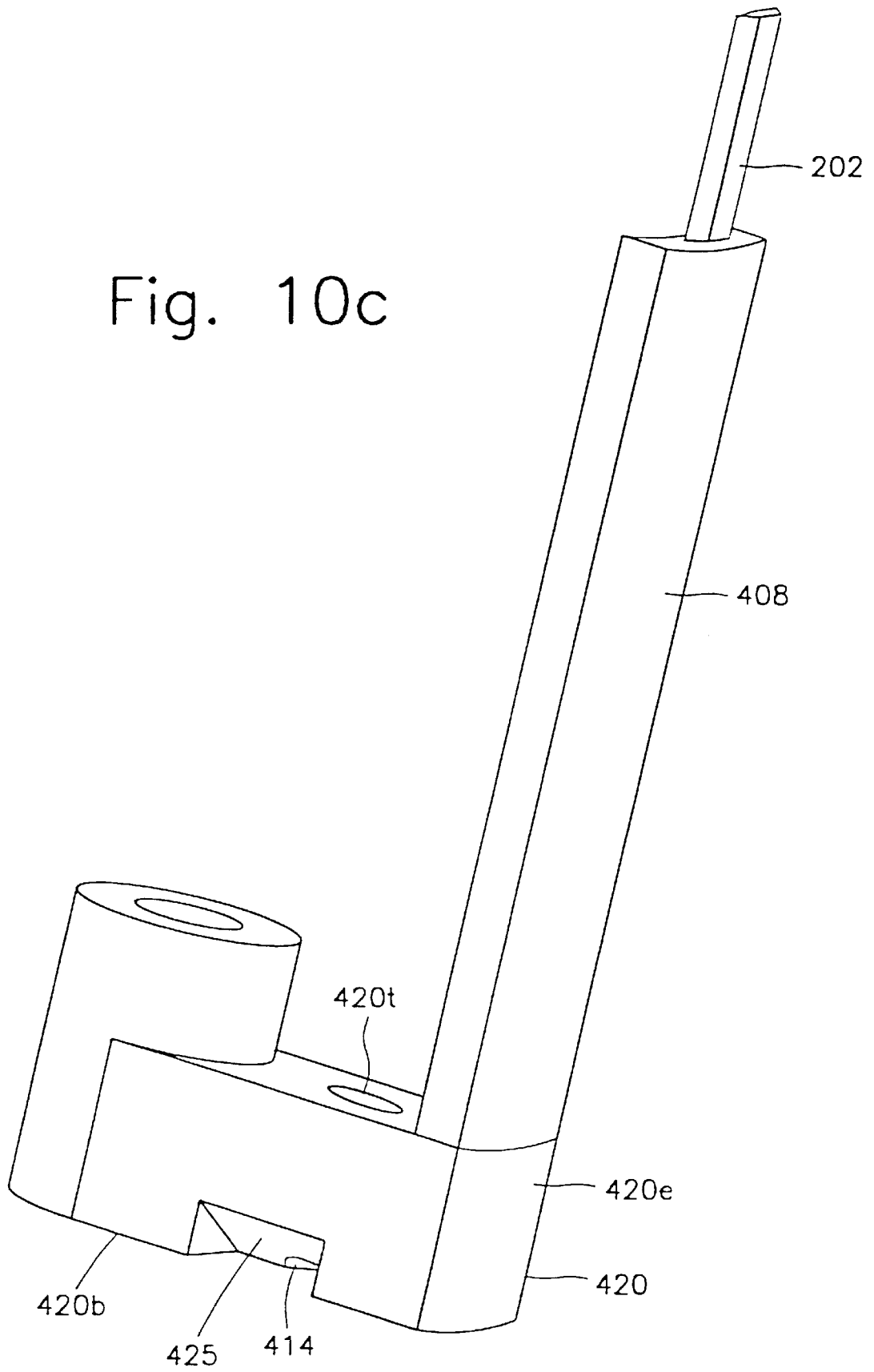

Fig. 10b

Fig. 10c



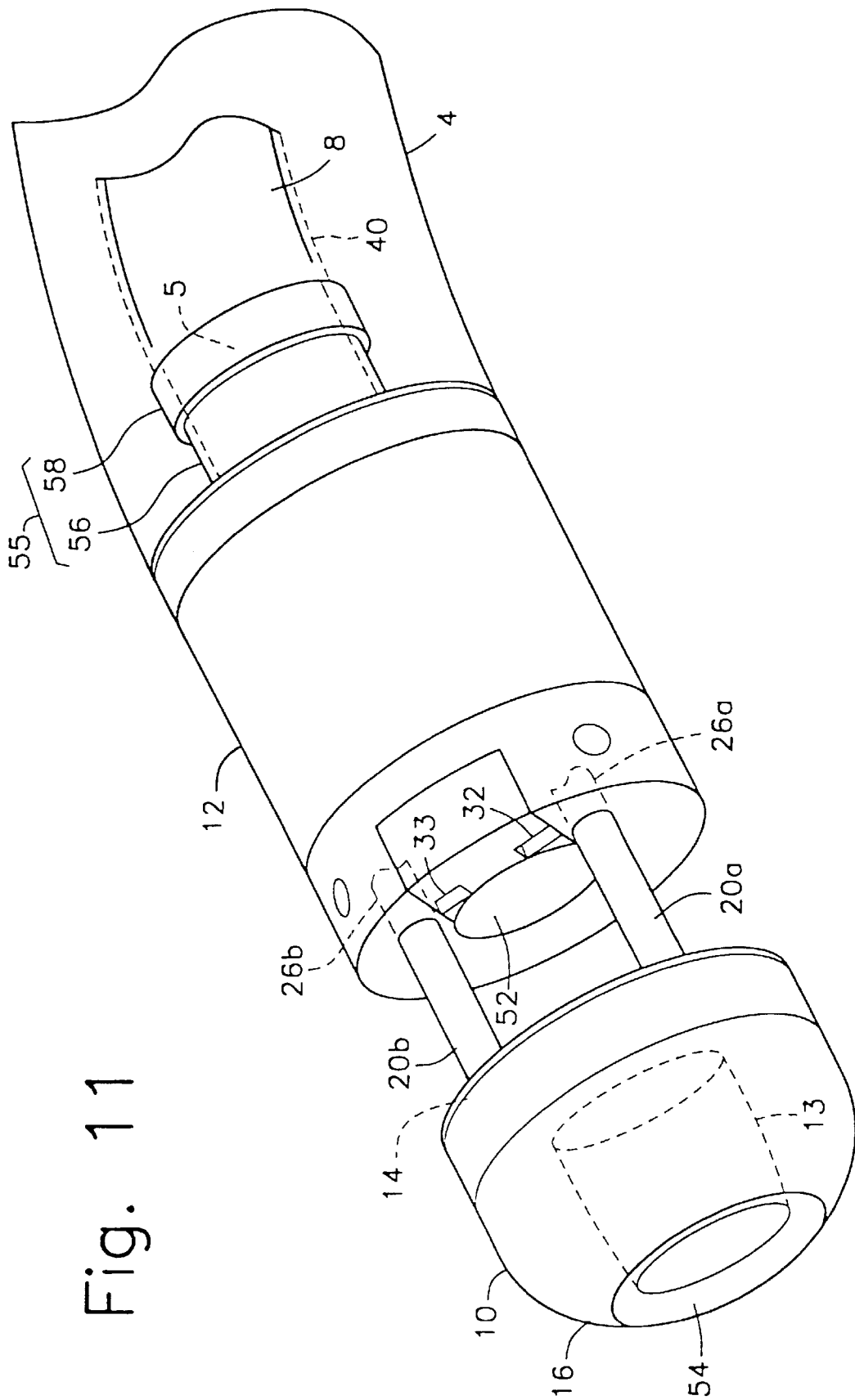

Fig. 11



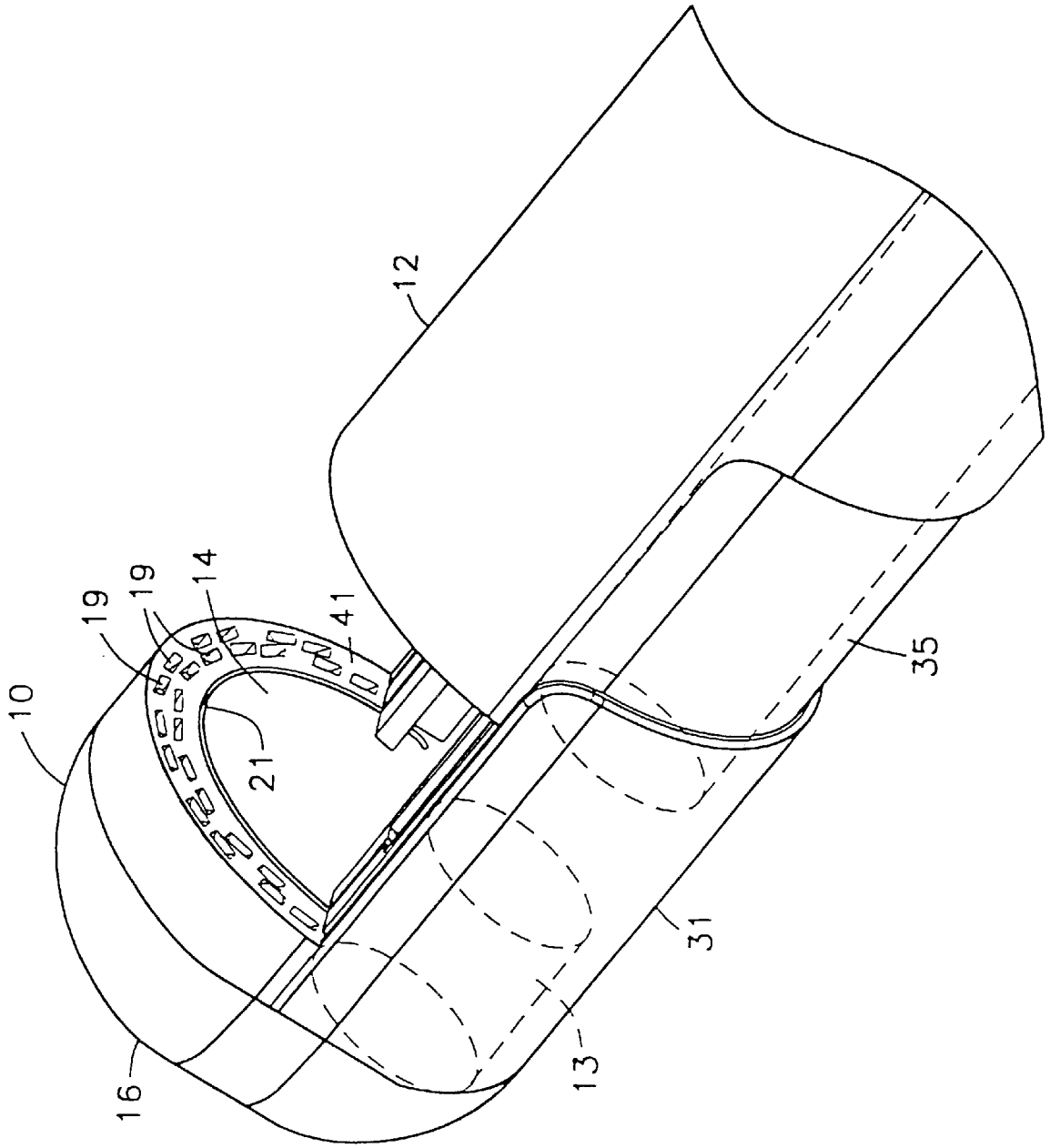
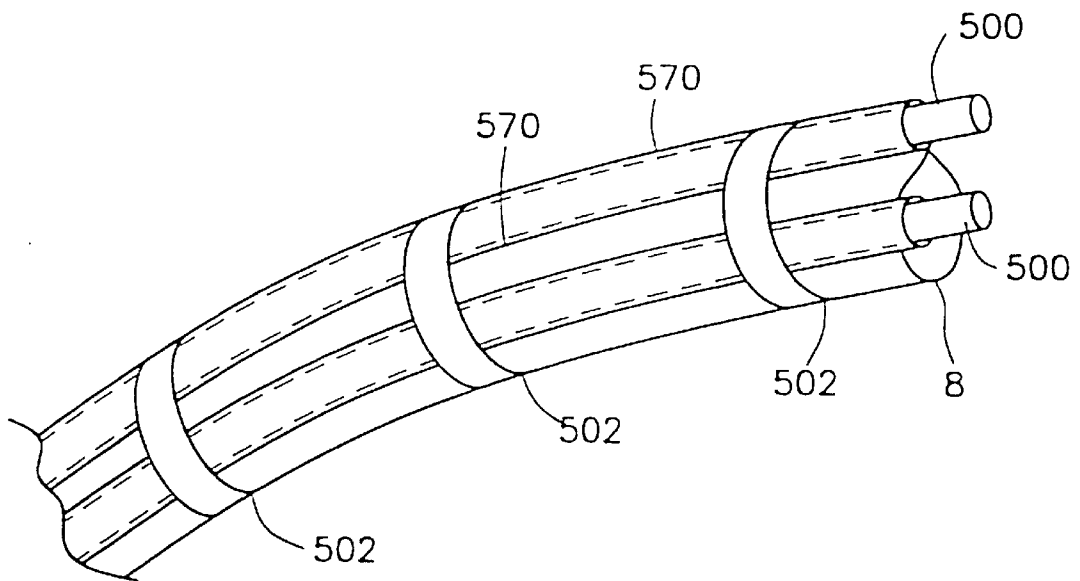
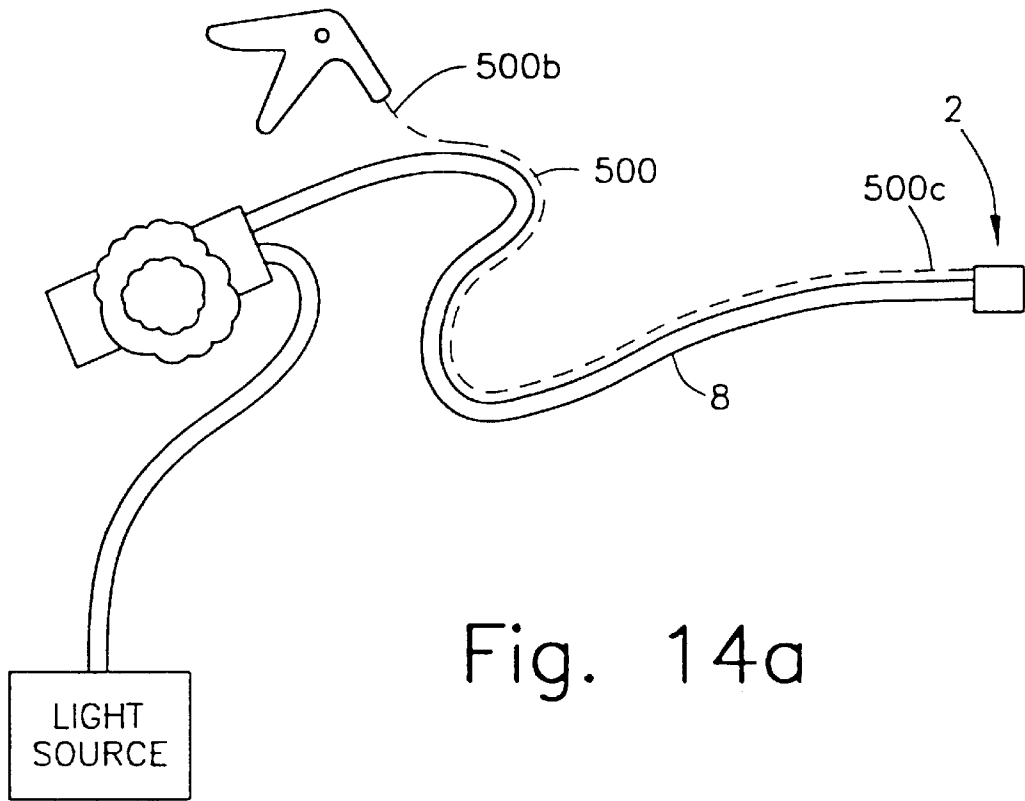

Fig. 13





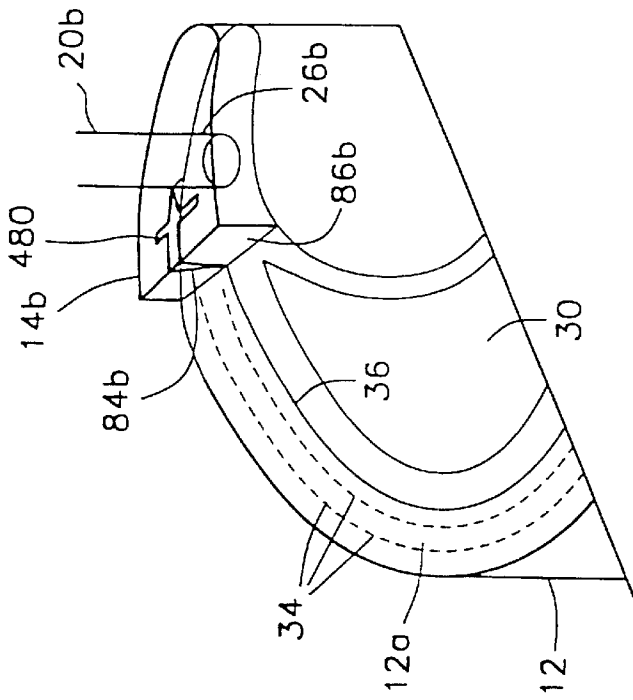

Fig. 16

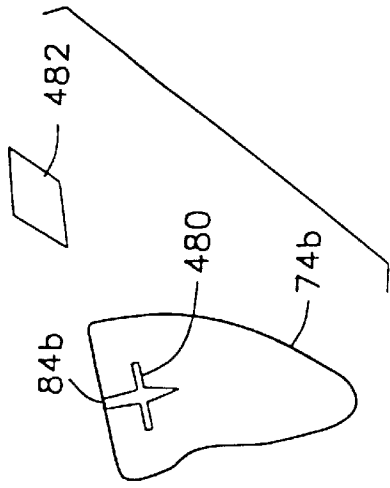

Fig. 17

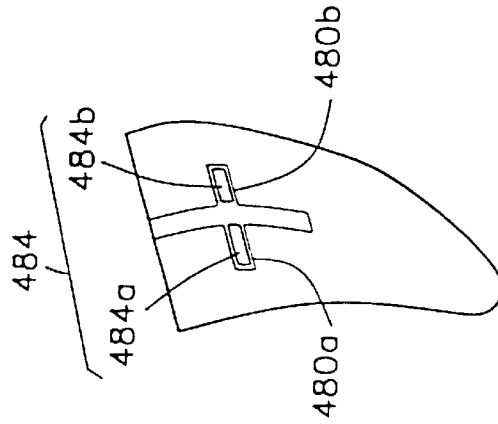

Fig. 18

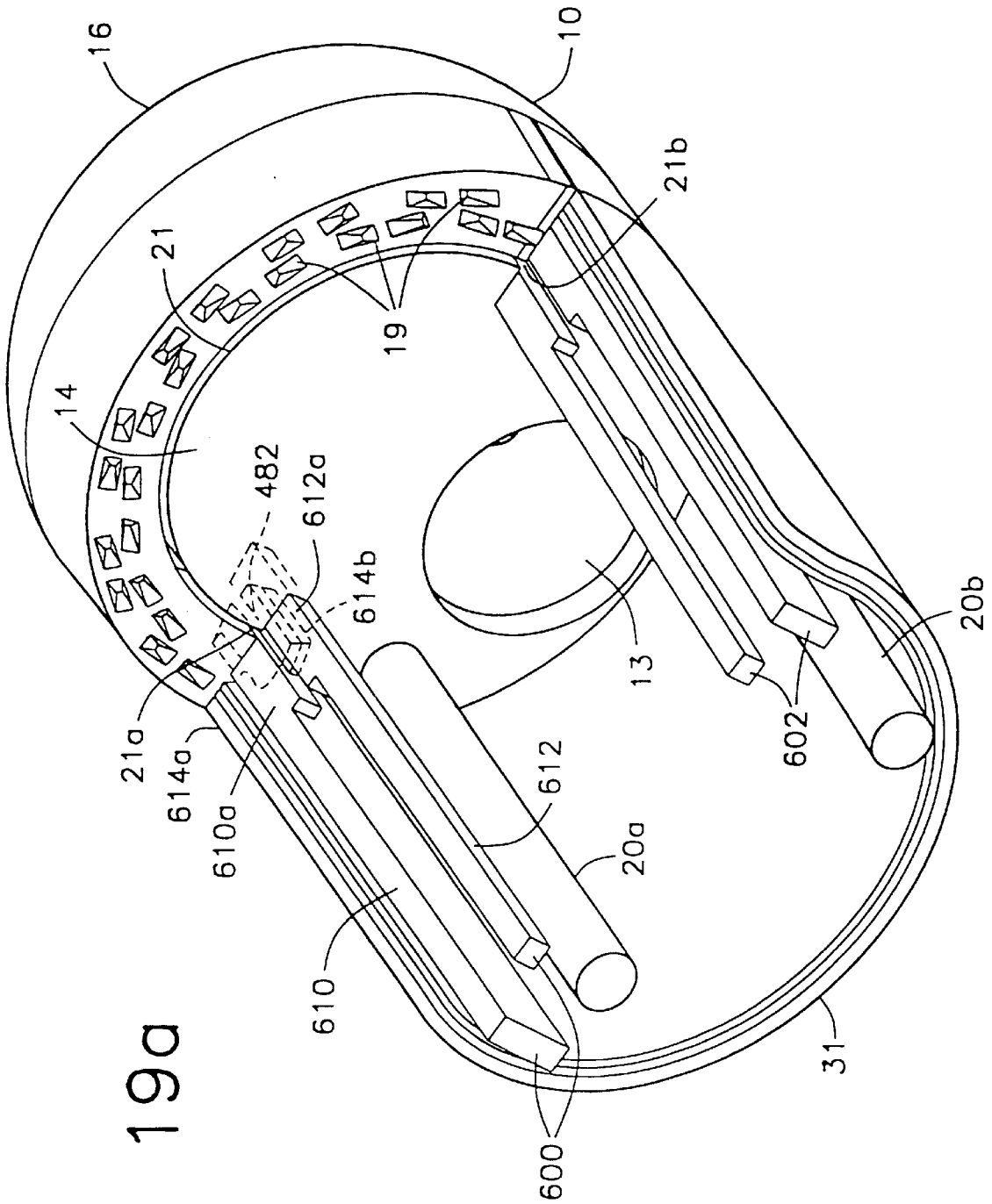

Fig. 19a

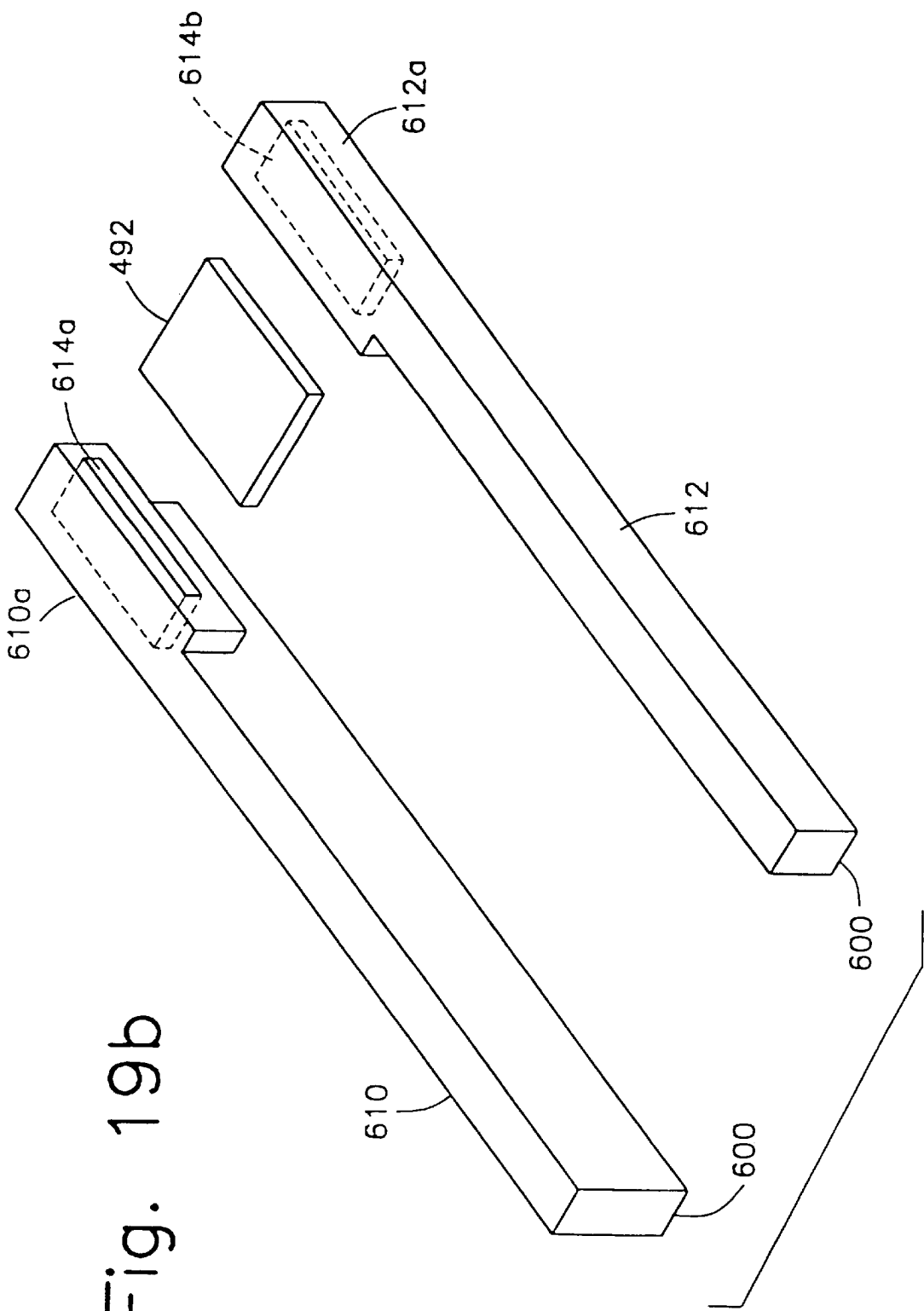

Fig. 19b

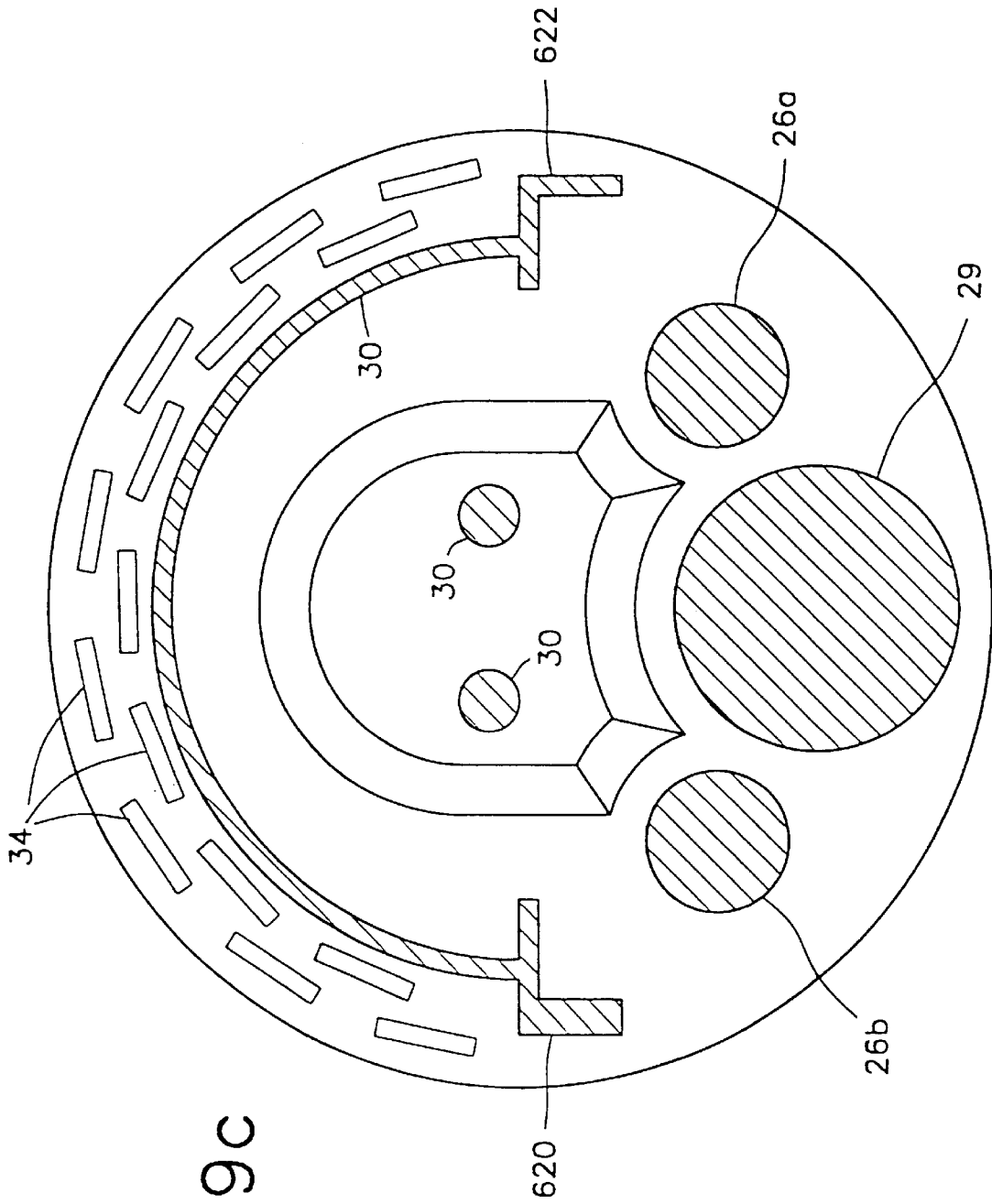

Fig. 19c

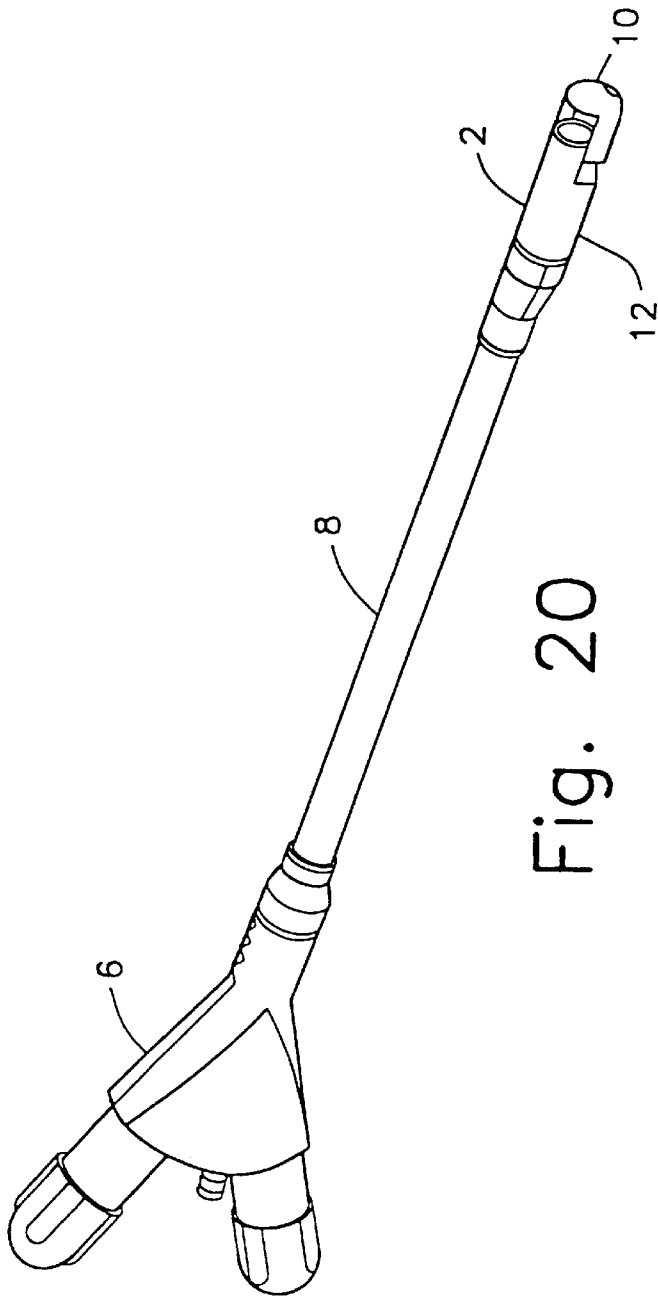

Fig. 20

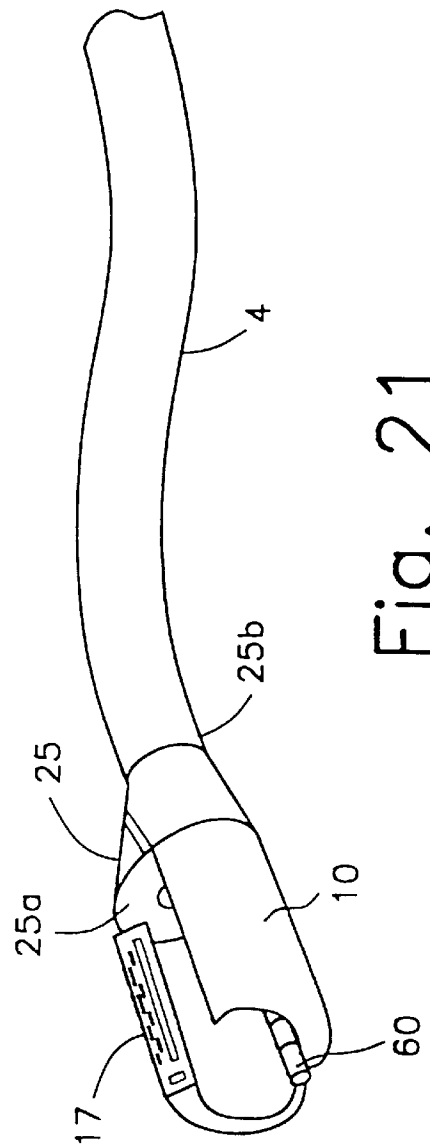

Fig. 21

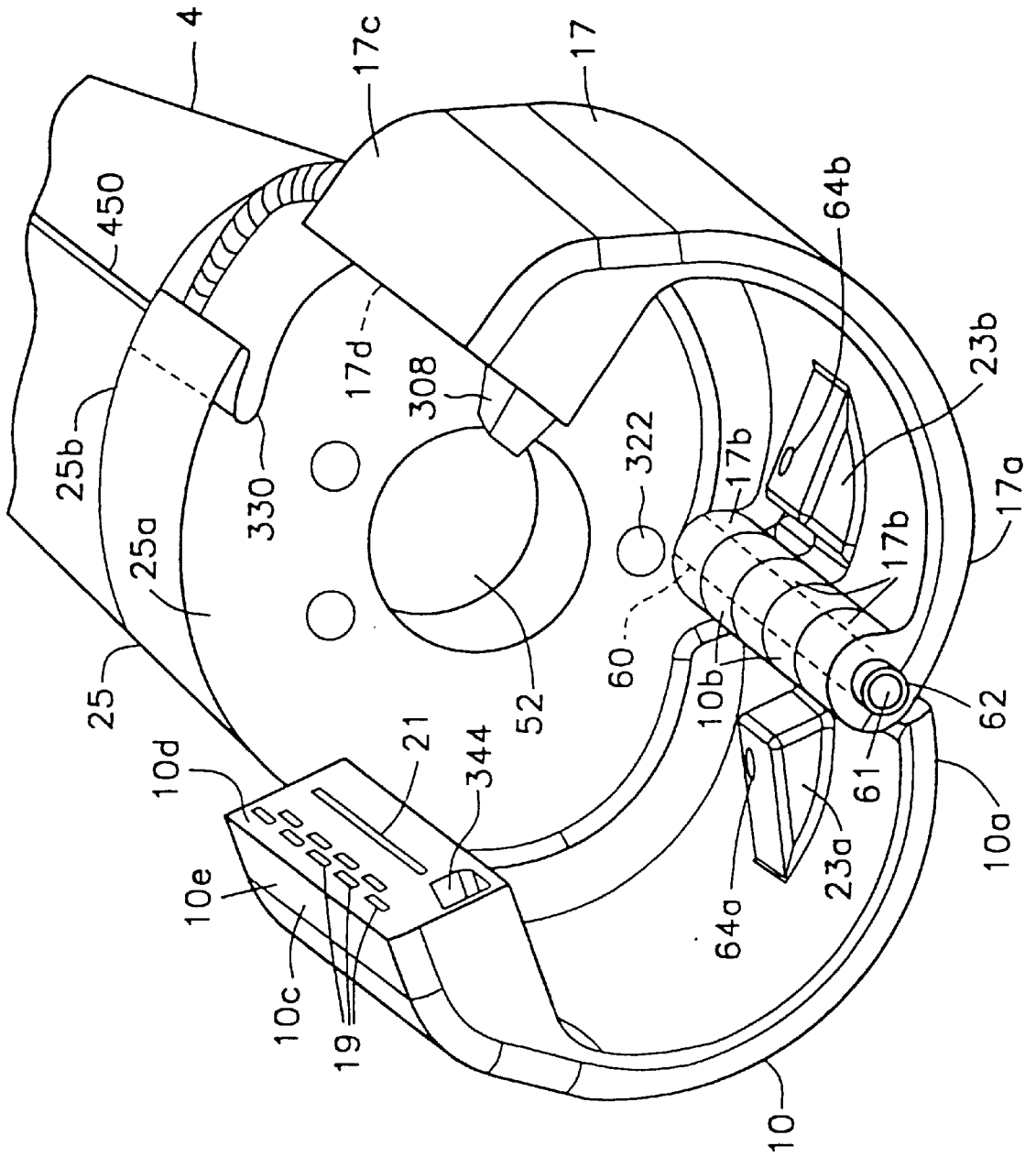

Fig. 22

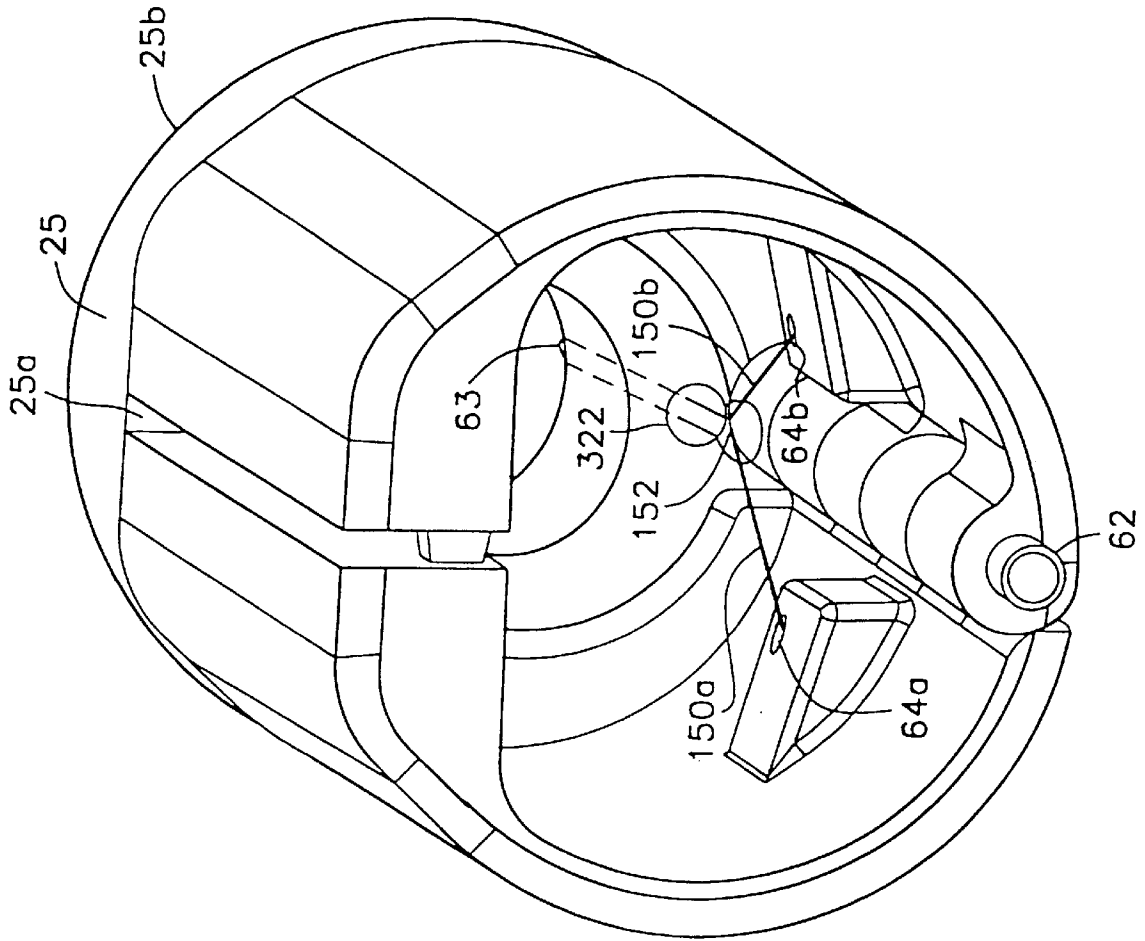

Fig. 23

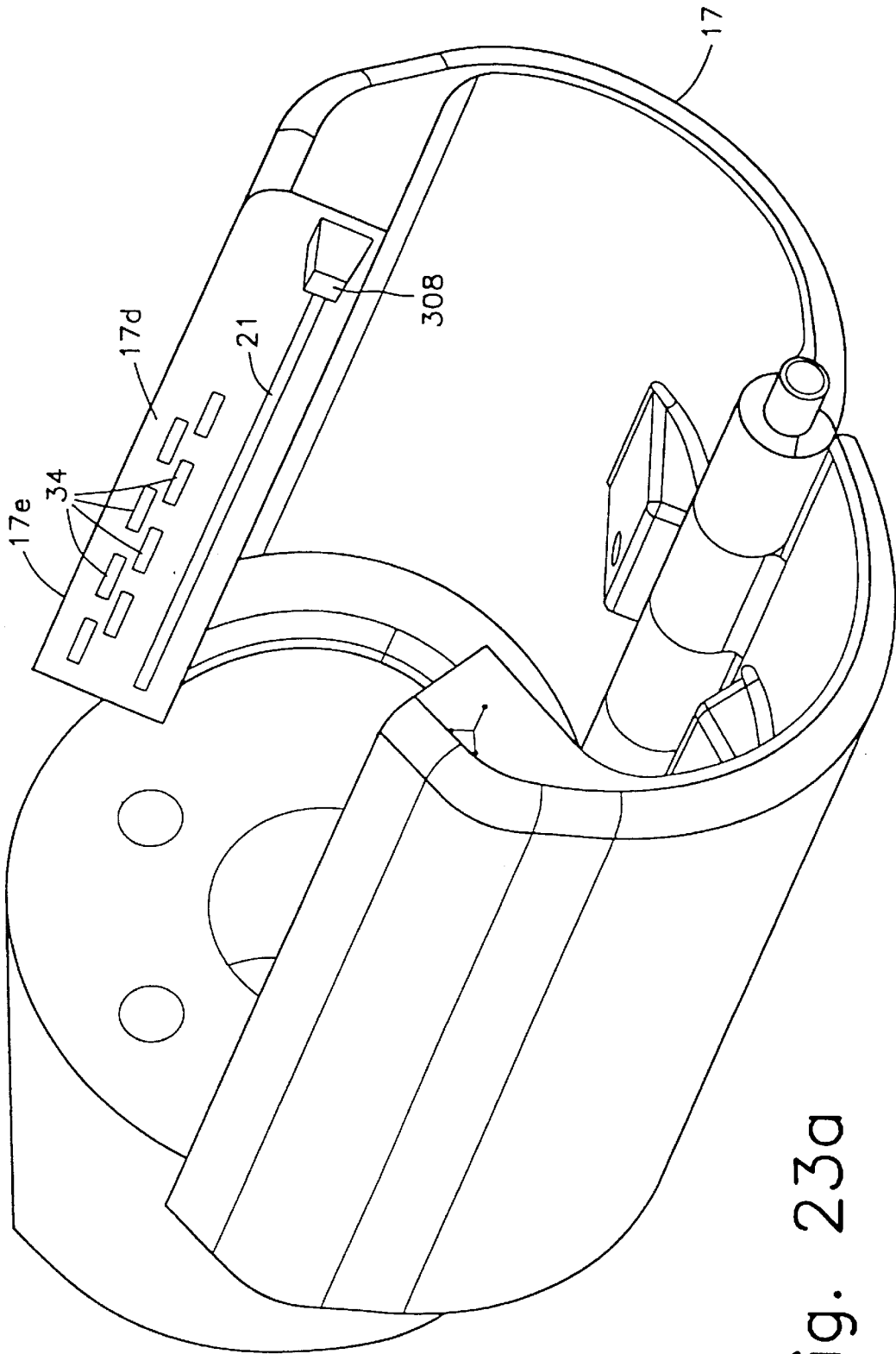

Fig. 23a

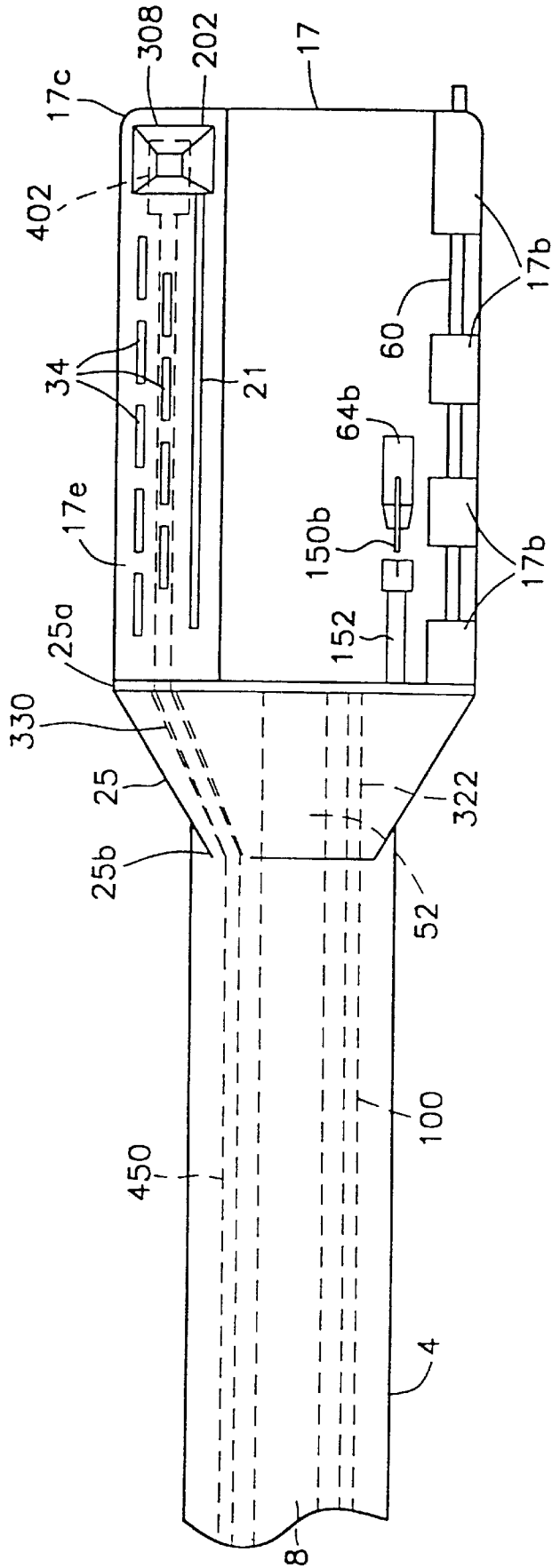

Fig. 24

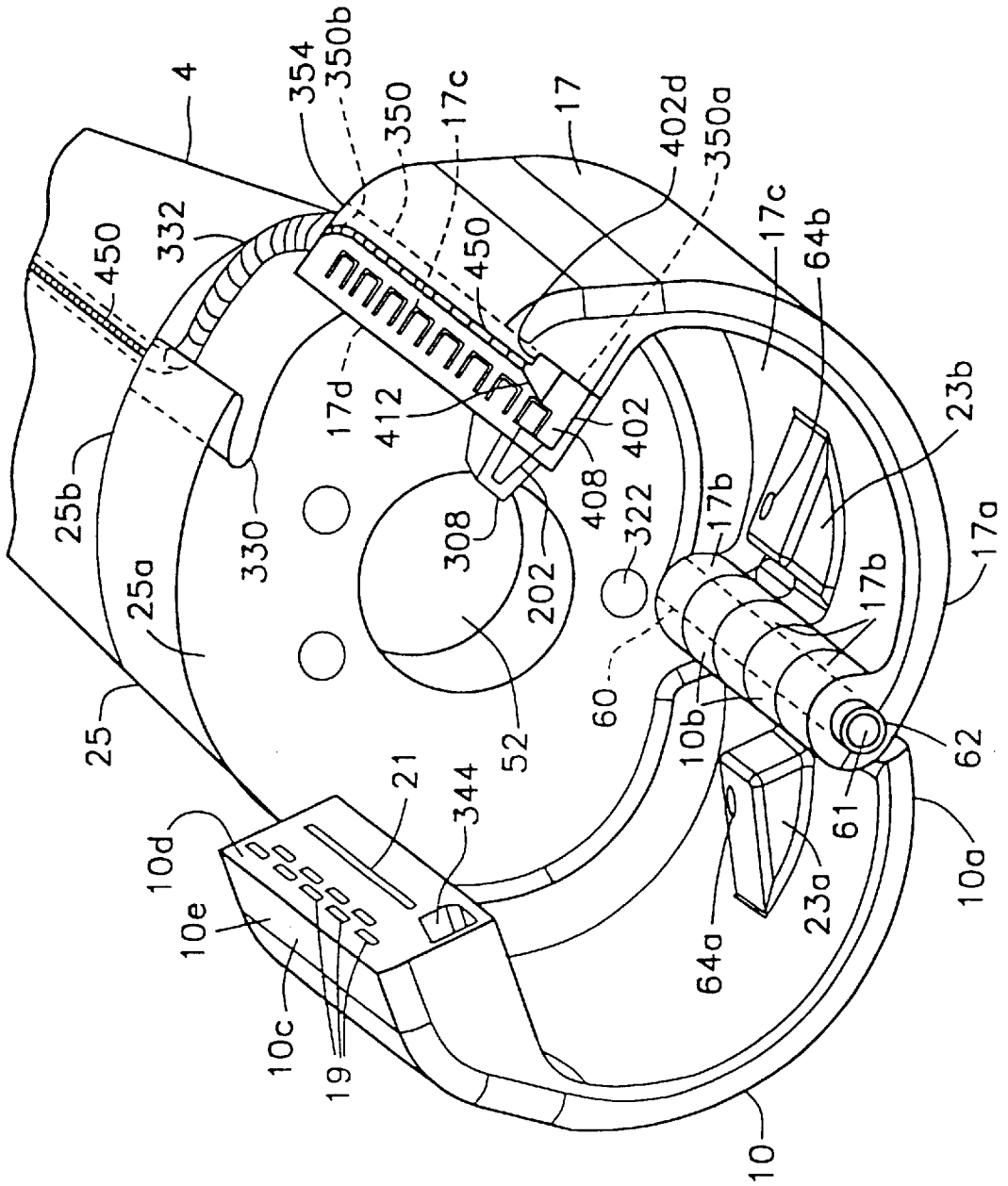

Fig. 25

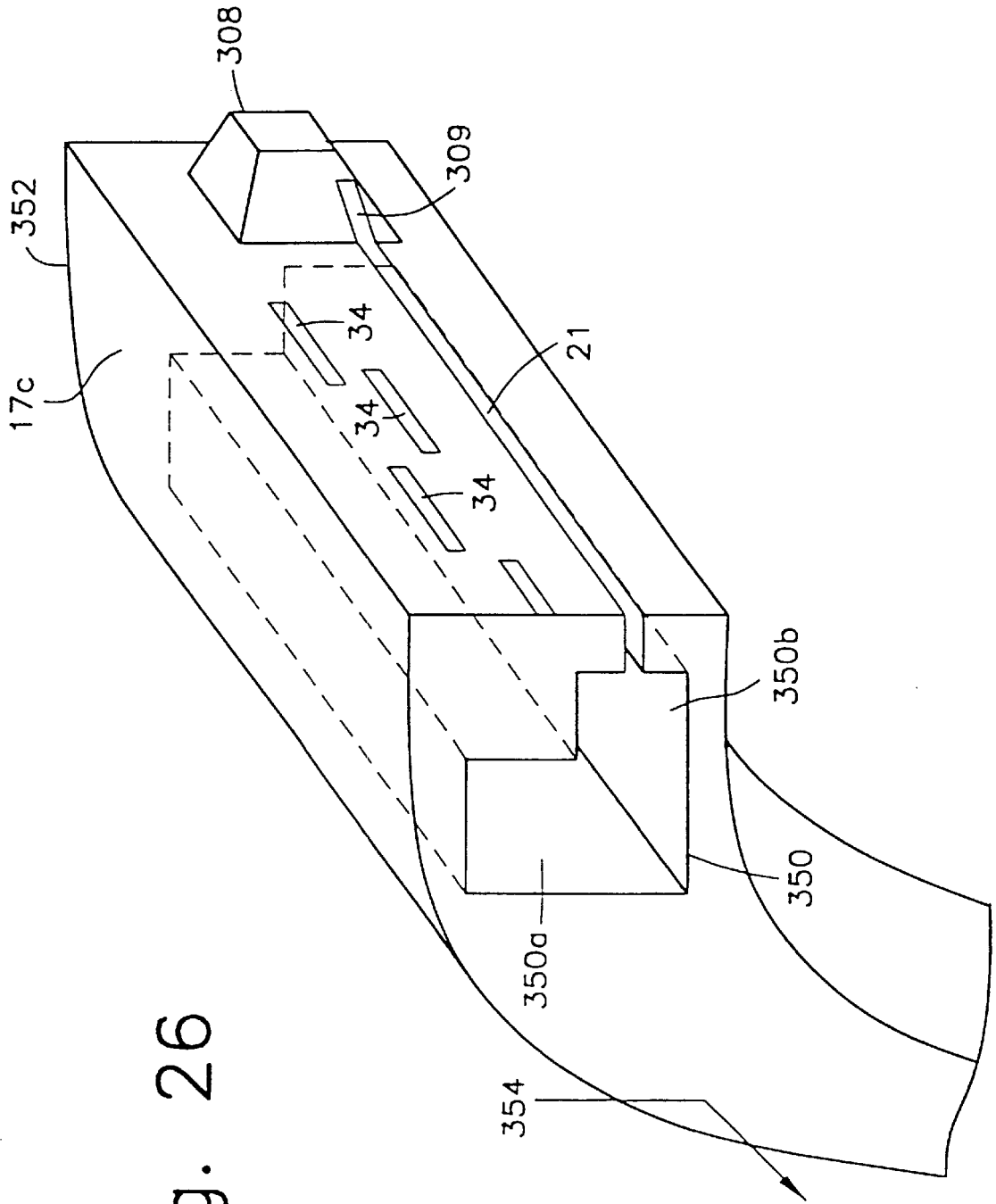

Fig. 26

1

## METHOD AND DEVICE FOR FULL THICKNESS RESECTIONING OF AN ORGAN

The present application is a continuation of application Ser. No. 09/694,894, filed Oct. 25, 2000, titled Method and Device for Full Thickness Resectioning of an Organ.

### FIELD OF THE INVENTION

The present invention relates to full thickness resection devices for performing localized resections of lesions in tubular organs, particularly the colon.

### BACKGROUND INFORMATION

A resection procedure involves excising a portion of an organ, approximating the surrounding tissue together to close up the hole created by the excision, and removing the excess tissue. Various conventional devices and procedures are available for resectioning lesions in tubular organs.

For example, several known resection devices and procedures requires at least one incision in an area near the portion of the organ to be excised for access to the lesion or treatment site (because, for example, the resectioning device may lack steering and/or viewing capabilities). Thus, the incision is required to allow the physician to access the organ section to be excised and guide the device to that section. Alternatively, when the organ section to be excised is beyond the reach of the surgical device, or the surgical device is not flexible enough to wind through the organ to the site to be excised, an incision will be required to position the device for the procedure. Of course, these incisions are painful and may involve a partial or entire loss of mobility while recuperating from the incision, in addition to recovering from the tubular resectioning procedure itself. In addition, the time required to recover from such a procedure is often longer than for procedures which do not require incisions.

One type of conventional resection procedure utilizes a circular stapling instrument in which a tubular section of a tubular organ is excised, resulting in the tubular organ being separated into a first segment and a second segment. The end sections of the first and second segments are then individually tied in a purse-string fashion, approximated, stapled, and the "purse-stringed" end sections are then cut off. In this full circle resectioning procedure, at least one separate invasive incision must be made near the section to be excised in order to cut and individually tie the separate end sections of the organ. Also, a separate incision is necessary to place one part of the resectioning device in the first segment and a corresponding second part of the device in the second segment so that the device can then bring the first and second segments together to re-attach the organ sections back together. A first of these separate parts may generally include a staple firing mechanism while the second part includes an anvil for forming the staples. Thus, this type of resectioning procedure involves the drawbacks mentioned above in regard to procedures requiring invasive incisions. In addition, the separation of the organ into two segments creates the risk of spillage of non-sterile bowel contents into the sterile body cavity, which can cause severe infection and possibly death.

An alternative resectioning device includes a stapling and cutting assembly on a shaft which can be bent or formed into a desired shape and then inserted into a patient's body cavity. Once the shaft has been bent into the desired shape, the rigidity of the shaft ensures that that shape is maintained

2

throughout the operation. This arrangement limits the effective operating range of the device as the bending of the shaft into the desired shape before insertion and the rigidity of the shaft once bent require the physician to ascertain the location of the organ section to be removed before insertion, and deform the shaft accordingly. Furthermore, the rigidity of the shaft makes it difficult to reach remote areas in the organ—particularly those areas which must be reached by a winding and/or circuitous route (e.g., sigmoid colon). Thus, an incision may be required near the organ section to be excised in order to position the device at the organ section to be excised.

### SUMMARY OF THE INVENTION

The present invention is directed to a full-thickness resection system comprising a flexible endoscope and a stapling mechanism, wherein the endoscope is slidably received through at least a portion of the stapling mechanism. The stapling mechanism includes an anvil and a stapling head mounted to the anvil so that the anvil and the stapling head are moveable with respect to one another between a tissue receiving position and a stapling position and wherein a gap formed between the stapling head and the anvil is larger in the tissue receiving position than it is in the stapling position. A position adjusting mechanism is provided for moving the anvil and the stapling head between the tissue receiving and stapling positions and a staple firing mechanism sequentially fires a plurality of staples from the stapling head across the gap against the anvil and through any tissue received in the gap and a knife cuts a portion of tissue received within the gap. A control unit which remains outside the body is coupled to the stapling mechanism for controlling operation of the position adjusting mechanism and the staple firing mechanism.

### BRIEF DESCRIPTION OF THE DRAWINGS

FIG. 1 shows a device according to a first embodiment of the present invention;

FIG. 2 shows the device of FIG. 1 mounted on a conventional endoscope;

FIG. 3 shows the device of FIG. 1 with a grasper mechanism extending therefrom;

FIG. 4 shows a cutaway of the device of FIG. 1 showing a drive mechanism thereof;

FIG. 5 shows a cutaway of the device of FIG. 1 showing an actuating mechanism;

FIG. 6 shows a detailed view of the wedge used in the actuating mechanism of FIG. 6;

FIG. 7 shows a cut-away view of a working head assembly of the device of FIG. 1;

FIG. 8 shows a rear cover plate of the working head assembly of FIG. 7;

FIG. 9a shows a mechanism for restricting motion of a drive shaft of the device of FIG. 1;

FIG. 9b shows a first coupling arrangement for a drive cable and a drive shaft in the device of FIG. 1;

FIG. 9c shows a second coupling arrangement for the drive cable and the drive shaft in the device of FIG. 1;

FIG. 9d shows a perspective cut-away view of a sheath of the device of FIG. 1;

FIG. 10a shows a perspective view of an alternative construction of the wedge of FIG. 6;

FIG. 10b shows a cut-away view of the wedge of FIG. 10a;

FIG. 10c shows a blade portion corresponding to the wedge of FIG. 10a;

FIG. 11 shows a device according to a second embodiment of the present invention;

FIG. 12 shows a device according to a third embodiment of the present invention;

FIG. 13 shows a device according to a fourth embodiment of the present invention;

FIG. 14a shows a device according to a fifth embodiment of the present invention;

FIG. 14b shows a detailed cut-away view of the device of FIG. 14a and a conventional endoscope;

FIG. 15 shows a control handle for use with the devices according to the present invention;

FIG. 16 shows a blade housing arrangement for use with a device according to the present invention;

FIG. 17 shows a first arrangement of a blade shield for use with a device according to the present invention;

FIG. 18 shows a second arrangement of the blade shield for use with a device according to the present invention;

FIG. 19a shows a third arrangement of the blade shield for use with a device according to the present invention;

FIG. 19b shows a tissue blocker of the blade shield of FIG. 19a;

FIG. 19c shows a distal end of a proximal housing of the device of FIG. 19a; and

FIG. 20 shows a device according to a sixth embodiment of the present invention.

FIG. 21 shows a device according to a seventh embodiment of the present invention.

FIG. 22 shows a first perspective view of the device of FIG. 21.

FIG. 23 shows a second perspective view of the device of FIG. 21.

FIG. 23a shows a third perspective view of the device of FIG. 21.

FIG. 24 shows a side cut-away view of the device of FIG. 21.

FIG. 25 shows a fourth perspective view of the device of FIG. 21.

FIG. 26 shows a cut-away view of an exemplary stapler member of the device of FIG. 1.

#### DETAILED DESCRIPTION

As shown in FIGS. 1 and 2, an apparatus according to a first embodiment of the present invention comprises a working head assembly 2 which may preferably be connected to a distal end 4a of a sheath 4. The proximal end 4b of the sheath 4 may preferably be connected to a control handle 6.

In operation, the entire apparatus is mounted onto an endoscope 8 by passing the endoscope 8 through the control handle 6, the sheath 4, and the working head assembly 2, as shown in FIG. 2. The endoscope 8 is then inserted into a body orifice to locate a lesion in the tubular organ under visual observation (usually while insufflating the organ). Once the lesion has been located, the working head assembly 2 and the sheath 4 are slidably advanced along the endoscope 8 into the tubular organ until the working head assembly 2 is in a desired position adjacent to the lesion. Those skilled in the art will understand that in an alternative embodiment, the working head assembly 2 may also be detachably coupled to a distal end of the endoscope 8, and the entire arrangement may then be inserted into the body orifice under visual observation.

As shown in FIG. 1, the working head assembly 2 comprises an anvil member 10 coupled to a distal end 12a of a proximal housing 12. The anvil member 10 has a substantially crescent-shaped cross-section (i.e., the outer edge 18 of the anvil member 10 substantially forms a portion of a first circle with a second smaller circular cut-out 13 formed within the first circle) with a proximal face 14 and a smaller distal face 16. The cut-out 13 of the anvil member 10 is included to allow the endoscope 8 to be slid through the entire working head assembly 2 so that the endoscope 8 may be advanced into the body passage allowing the working head assembly 2 to later be advanced into the body to the lesion. In addition, the cut-out 13 also provides forward vision via the endoscope 8. Thus, any shape of the cut-out 13 may be selected which is large enough to accommodate the endoscope 8, with a larger cut-out providing a larger field of vision. An outer surface 18 of the anvil member 10 extends substantially parallel to a central axis of the working head assembly 2 while the proximal and distal faces 14, 18 of the anvil member 10 extend in planes substantially perpendicular to the central axis. The outer surface 18 is joined to the distal face 16 by a tapered portion 5.

As shown in FIG. 3, the proximal face 14 of the anvil member 10 includes a first cavity 37 and a rim 41 encircling the first cavity 37. A plurality of staple-forming grooves 19 are arranged in two offset rows on the rim 41 of the anvil member 10 and a circular guiding slit 21 extends radially within the rows of grooves 19. The rim 41 protrudes from the remainder of the proximal face 14 so that a shallow cavity is formed on the proximal face 14.

The anvil member 10 is coupled to the proximal housing 12 by means of two mounting shafts 20a and 20b, which may preferably be substantially cylindrical. Each mounting shaft 20a, 20b is coupled to the proximal face 14 of the anvil member 10 on a respective one of two horns 22a, 22b formed by the crescent-shaped anvil member 10. Although the anvil member 10 is shown fixedly coupled to the mounting shafts 20a, 20b, those skilled in the art will understand that the anvil member 10 may also be pivotally coupled to the mounting shafts 20a, 20b in order to provide a greater field of vision through the endoscope 8 as shown in FIG. 3a. In this pivoted-type arrangement, the anvil member 10 is angled in a first configuration so that the horns 22a, 22b are closer to the distal end 12a of the proximal housing 12 than the rest of the anvil member 10. Then, as the anvil member 10 is drawn towards the distal end 12a of the proximal housing 12, the anvil member 10 would be pressed against the distal end 12a beginning with the horns 22a, 22b, which would cause the anvil member 10 to pivot until the proximal face 14 of the anvil member 10 is parallel to the distal end 12a.

As shown in FIG. 1, the mounting shafts 20a, 20b are slidably received in mounting holes 26a, 26b, which have a size and shape substantially corresponding to the size and shape of the mounting shafts 20a, 20b and which run axially through the proximal housing 12. The mounting shafts 20a, 20b are preferably movable axially proximally and distally within the mounting holes 26a, 26b between a proximal most position in which a tissue gripping gap of a first predetermined width is formed between the rim 41 and the distal end 12a of the proximal housing 12, and a distal most position in which a tissue receiving gap of a larger second predetermined width is formed between the rim 41 and the distal end 12a of the proximal housing 12.

The second predetermined width should preferably be more than twice the thickness of a wall of the organ being resected so that a section of the tubular organ may be

pulled into a resectioning position between the anvil member **10** and the proximal housing **12**.

As shown in FIG. **4**, the proximal end of at least one of the mounting shafts **20a** and **20b** is coupled to a drive mechanism **102** provided within the proximal housing **12**. In a preferred embodiment, the drive mechanism **102** is composed of a yoke **103** and a drive shaft **105**. The yoke **103** is preferably slidably received within the proximal housing **12** for longitudinal movement along the axis of the proximal housing **12** so that, when the anvil member **10** is in the proximal most position, the yoke **103** is in a corresponding proximal most position and, when the anvil member is in the distal most position, the yoke **103** is in a corresponding distal most position.

The yoke **103** may preferably be substantially semicircular with a substantially rectangular cross-section. Although the semicircle formed by the yoke **103** in FIG. **4** forms substantially a quarter arc of a circle, the yoke **103** may form a larger semicircle based upon the interior accommodations of the proximal housing **12** and the position of the mounting shafts **20a**, **20b**. The mounting shaft **20a** may preferably be coupled to the yoke **103** at a first end **103a** of the yoke **103**, and the mounting shaft **20b** may be coupled at a second end **103b** of the yoke **103**. A shaft hole **107**, having a diameter substantially corresponding to a diameter of a complementarily threaded distal end **105a** of the drive shaft **105**, extends through the yoke **103** at a point substantially midway between the first end **103a** and second end **103b**. Thus, when the drive shaft **105** is rotated, the threaded distal end **105a** engages the shaft hole **107** to move the yoke **103** proximally or distally (in dependence upon the direction of rotation of the drive shaft **105**).

The distal end **105a** of the drive shaft **105** should preferably be threaded over a first section **105t** substantially corresponding in length to at least the distance between the proximal and distal most yoke positions, while a remainder portion **105r** may have no threads thereon. The drive shaft **105** may have an increased cross-section in the areas immediately adjacent to the threaded first section **105t** (proximally and/or distally of section **105t**), thereby limiting the movement of the yoke **103** to the first section **105t**. Those skilled in the art will understand that the drive shaft **105** is preferably rotatably mounted within the proximal housing **12** so that it may only rotate and may not move relative to the proximal housing **12**. The drive shaft **105** preferably extends to a proximal end **105b** which is coupled to a drive cable **100** which extends to the control handle **6** through the sheath **4**. The drive cable **100** may preferably run axially along the peripheral interior of the sheath **4**. Those skilled in the art will understand that the sheath **4** is preferably torsionally stiff to resist the torque forces from the drive cables rotating therein. However, the sheath **4** is longitudinally flexible to so that it may be slidably advanced along the endoscope **8**, while minimizing interference with the operation of the endoscope **8** and trauma to surrounding tissue. The sheath **4** is preferably constructed similar to known endoscope insertion tubes, which are flexible yet allow the transfer of forces to swivel the distal end of the endoscope **8** in multiple directions and the torqueable rotation of the endoscope.

FIGS. **7-10** show a cutaway view of the working head assembly **2** in FIG. **1**, in which the respective movements of the drive shaft **105** and the yoke **103** are restricted in the manner described above. As shown in FIG. **8**, a pear-shaped rear cover plate **460** may preferably be connected to the proximal end **12b** of the proximal housing **12**. A first shaft hole **462** having a cross-sectional size substantially corresponding to the cross-sectional size of the drive shaft **105** is

provided in a lower portion of the rear cover plate **460** for receiving the drive shaft **105** therethrough. Thus, the yoke **103** is restricted to only longitudinal movement in this arrangement because, the distal side of the yoke **103** is coupled to the mounting shafts **20a**, **20b** which are disposed in the mounting holes **26a**, **26b**, and the proximal side of the yoke **103** is coupled to the drive shaft **105** which is disposed in the first shaft hole **462**.

As shown in FIG. **9a**, the movement of the drive shaft **105** may be restricted to only rotation movement about its axis by two washer-type devices **470** fixedly attached to the drive shaft **105** on either side of the rear cover plate **460**. A similar result may be achieved by providing the drive shaft **105** with a larger cross-sectional size on either side of the rear cover plate **460** in relation to the portion of the drive shaft **105** within the rear cover plate **460**. Alternatively, the cross-section of a bulging portion **476** of the drive shaft **105** located substantially in the center of the rear cover plate **460** may be larger than the portions of the drive shaft **105** immediately adjacent to the bulging portion **476**. The first shaft hole **462** may then have a center portion **474** with a larger cross-section than the rest of the first shaft hole **462** to accommodate the bulging portion **476** of the drive shaft **105**.

FIG. **9b** shows a coupling arrangement between the drive cable **100** and the drive shaft **105** in which a proximal end **105a** of the shaft may have a D-shaped hole **105h** extending therethrough. A distal end **102b** of the drive cable **100** has a D-shape corresponding to the shape of the hole **105h** so that the distal end **102b** of the drive cable may be received within the hole **105h** in the drive shaft **105**. FIG. **9c** shows an alternative coupling arrangement for coupling the drive cable **100** to the drive shaft **105** in which the hole **105h** in the proximal end **105a** of the drive shaft **105a** and the distal end **102b** of the drive cable **100** have corresponding squarish shapes. The single edge provided by the D-shapes in FIG. **9b** and the four edges provided by the squarish shapes in FIG. **9c** allow the drive cable **100** to transfer a rotational force to the drive shaft **105** with minimal slippage.

In operation, the user advances the endoscope **8**, with the working head assembly **2** received therearound, to a portion of tissue to be resectioned until the working head assembly **2** is in a desired position adjacent to the tissue to be resectioned. The user may then apply a force to the control handle **6** to rotate the drive cable **100** which in turn rotates the drive shaft **105** to advance the yoke **103** and the anvil member **10** distally away from the distal end **12a** of the proximal housing **12**. As shown in FIG. **3** when the anvil member **10** has reached the distal most position, a known grasping device **108** is advanced through the sheath **4** and through the working head assembly **2** to enter the gap between the anvil member **10** and the distal end **12a** via one of the grasper holes **32** and **33**. Although the device in FIG. **3** is shown using a duodenoscope as the endoscope **8**, those skilled in the art will understand that other types of endoscopes may also be used, such as, for example, gastroscope, colonoscope, etc.

As shown in FIG. **1**, at least the distal end **12a** of the proximal housing **12** preferably has a cross-section corresponding in size and shape to the proximal face **14** of the anvil member **10**, including a cut-out **29** substantially corresponding in size and shape to the cut-out of anvil member **10**. The cut-out **29** is provided to receive the endoscope **8** therein and allow the proximal housing **12** to be slidably advanced along the endoscope **8**. Of course, those skilled in the art will understand that the shape of the outer surface of the working head assembly **2** may be selected in order to

accommodate various desired resectioning shapes, and the shape of the anvil member **10** may preferably be selected to form a continuous surface when positioned adjacent to the proximal housing **12** to facilitate advancing the working head assembly to into and removing it from, body passages. It is preferable that the working head assembly have a maximum diameter at any point between 15 mm and 40 mm.

A tissue receiving cavity **30** is formed substantially centrally in the distal end **12a** of the proximal housing **12** to facilitate the drawing of sections of tubular organs into the gap between the anvil member **10** and the distal end **12a**. Those skilled in the art will understand that the depth of the cavity **30** may vary depending on the amount of tissue to be pulled into the cavity **30** and the size of the proximal housing **12**. Two grasper holes **32** and **33** extend axially, preferably slightly off-center from the longitudinal axis of the proximal housing **12**. In a preferred embodiment, the grasper holes **32** and **33** may each preferably receive a grasping device **108** advanced from the control handle **6**, through the sheath **4**, and through a respective one of the grasper holes **32** and **33**.

In operation, either one or two grasping devices **108** may then be used to pull a section of the tubular organ between the anvil member **10** and the distal end **12a** of the proximal housing **12** and into the cavity **30**. A third grasping device **108** may also be inserted through the working channel of the endoscope **8** to provide another means of positioning the organ section between the anvil member **10** and the proximal housing **12**. Of course, those skilled in the art will understand that any desired instrument may be advanced to the gap between the anvil member **10** and the distal end **12a** through any of the grasper holes **32**, **33** and the working channel of the endoscope **8**.

A plurality of staple slits **34** are preferably disposed in two offset substantially circular rows extending along the periphery of the distal end **12a** of the proximal housing **12**. The staple slits **34** extend from an area adjacent to the mounting shaft **26a** to an area adjacent to the other mounting shaft **26b**. The plurality of staple slits **34** may preferably be arranged so that when the anvil member **10** is in the proximal most position, each of the staple slits **34** is aligned with a corresponding one of the staple-forming grooves **19**.

When the device is configured for operation, a plurality of staples is received within the working head assembly **2** with each of the staples being aligned with a respective one of the staple slits **34**. The staples are then sequentially fired from the respective staple slits **34** by an actuating mechanism **104** (shown in FIG. **5**) disposed in the proximal housing **12**.

A substantially circular blade slit **36** extends substantially radially within the staple slits **34** so that, when the anvil is in the proximal most position, the blade slit **36** is aligned with the guiding slit **21** on the anvil member. As shown more clearly in FIG. **12**, extensions **84a** and **84b** of the blade slit **36** extend into blade housings **74a** and **74b**, respectively, which project distally from the distal end **12a** of proximal housing **12**. The blade housings **74a** and **74b** are preferably situated so that when the anvil member **10** is in its proximal most position, the blade housings **74a** and **74b** contact portions **43a** and **43b** of the rim **41** of the anvil member **10**. The extension of the blade housings **74a** and **74b** from the proximal housing **12** is preferably selected so that when the blade housing devices **74a** and **74b** engage the remainder portions **43a** and **43b** of the rim **41** (thereby stopping a proximal movement of the anvil member **10** and defining the proximal most position thereof), a gap is formed between the anvil member **10** and the distal end **12a** of a length sufficient to allow the anvil member **10** to securely hold a portion of

the organ against the proximal housing **12** without crushing and damaging the portion of the organ.

When positioned at one end of the blade slit **36** (i.e., in one of the extensions **84a** and **84b**), a cutting blade **202** is preferably completely enclosed within the respective one of the blade housing devices **74a** and **74b** and the guiding slit **21**, so that the cutting blade **202** does not cut any tissue until the physician intentionally operates the blade **202**. When the physician operates the blade **202**, the blade **202** is driven from its initial position received within one of the extensions **84a** and **84b** around the blade slit **36** with its cutting edge facing a direction of movement, until the blade **202** is received into the other one of the extensions **84a** and **84b**. Thus, after a cutting operation has been performed, the blade **202** is once again prevented from inadvertently injuring the patient.

FIG. **6** shows a wedge **402**, a first portion **402a** of which is non-rotatably coupled to an actuating shaft **400** so that rotation of the shaft **400** the wedge **402** rotates, preferably about the longitudinal axis of the working head assembly **2**. The wedge **402** includes a blade handle **408** which extends from a first portion **408a** coupled to the wedge **402** to a second portion **408b** which is coupled to the blade **202** so that, when the wedge **402** is rotated, the blade **202** is rotated through the blade slit **36**. The wedge **402** has a substantially bell-like cross-section when viewed axially, with a second portion **402b** extending radially outward from the first portion **402a** and, consequently, from the longitudinal axis of the shaft **400** which preferably coincides with the longitudinal axis of the working head assembly **2**. A notch of varying depth is cut out of a radially outer portion of the second portion **402b** to form a cam surface **412** thereon. A first ramp section **412a** ramps up from a leading face **402d** of the wedge **402** to adjoin a second ramp section **412b** that ramps down to adjoin a rear face **402e** of the wedge **402**. The wedge **402** is preferably arranged in the proximal housing **12** so that the cam surface **412** is substantially aligned with the staple slits **34**.

A staple driver **472** extends substantially longitudinally, proximally from each of the staple slits **34** having toward the plane in which the wedge **402** rotates and each staple driver **472** is slidably received within the working head assembly **2** for motion between a distal most, staple driving position and a proximal most inoperative position. In the inoperative position, an upper end of each of the staple drivers **472** is completely received within the proximal housing **12**, just proximal of a respective staple. The staple drivers **472** are preferably substantially rectangular in shape, although bottom edges **472a** thereof may more preferably be rounded. The length of the staple drivers **472** is preferably selected so that, in the inoperative position, the bottom surfaces **472a** extend into the plane of rotation of the wedge between the proximal and distal most extents of the first ramp portion **412a**. The bottom surfaces **472a** are, in the inoperative position, more preferably substantially aligned with the distal most projection of the of the cam surface **412** at the leading face **402d**. Thus in operation, the wedge **402** is rotated by the actuating shaft **400** so that the first ramp section **412a** of the cam surface **412** successively drives each of the staple drivers **472** into contact with a corresponding staple so that each staple driver **472** and its staple are driven distally through a respective one of the staple slits **34**. This drives the staples across the gap from the distal end **12a** into the anvil member **10**, through any tissue held between the anvil member **10** and the proximal housing **12**, and into the corresponding staple forming grooves **19**. Thus the section of the tissue gripped between the anvil member

10 and the proximal housing 12 is stapled in a pattern substantially the same as that formed by the staple slits 34 (i.e., substantially circular). At the same time, the blade 202 is rotated through the blade slit 36 to cut the tissue which has just been stapled through the rotation of the wedge 402.

After each of the plurality of staples has been fired, the wedge 402 may be driven in a reverse direction to reload a new plurality of staples. The wedge 402 may rotate in a direction opposite the staple firing direction without getting caught on any of the staple drivers 472 because the staple drivers are pushed out of the way by the second ramp section 412b of the cam surface 412.

In operation, the user applies a force to the control handle 6 to rotate an actuating cable 450 about its longitudinal axis. This rotational force is transferred to the actuating shaft 400, which then rotates the wedge 402 around the longitudinal axis of the actuating cable 450. The first ramp section 412a of the cam surface 412 of the wedge 402 then individually drives the staple drivers 472 distally as described above to staple the tissue received between the anvil member 10 and the proximal housing 12 with the cutting blade 202 lagging behind the firing of the stapling since the blade handle 408 is coupled to the rear face 402e of the wedge.

FIG. 10a shows an alternative configuration of the wedge 402 of FIG. 6 including a separate blade portion 420. The blade portion 420 is preferably rotatably coupled to the distal end 400a of the actuating shaft 400 so that a rotation of the actuating shaft 400 about its longitudinal axis does not cause a corresponding rotation of the blade portion 420. As in FIG. 6, the wedge 202 of this apparatus is non-rotatably coupled to the distal end 400a of the shaft 400.

The blade handle 408 of this apparatus, which is coupled to a peripheral edge 420e of the blade portion 420, extends to the cutting portion of the blade 202. As described above, the cutting portion of the blade 202 extends past the distal end 12a except when the blade 202 is received within one of the extensions 84a and 84b.

The wedge 402 substantially corresponds in shape and size to the wedge 402 of FIG. 6, except that the blade handle 408 is not coupled thereto. In addition, a locking shaft 402h extends into a distal surface 402f located as shown in FIG. 10a so that when the blade portion 420 and the wedge portion 410 are aligned, the locking shaft 402h and a locking dimple 414 (shown in FIG. 10c) on the bottom face 420b of the blade portion 420 are substantially aligned. As shown in FIG. 10b, a spring 416 is received within the locking shaft 402h with a proximal end of the spring coupled to the proximal end of the locking shaft 402h. A locking ball 418 coupled to the distal end 416b of the spring 416 is sized so that when a proximally directed force is applied to the locking ball 418, the locking ball 418 may be slidably received within the locking shaft 402h. In addition, when no distally directed force is applied to the locking ball 418, the spring 416 preferably extends so that approximately one half (or more) of the locking ball 418 extends distally out of the locking shaft 402h. Thus, when the wedge 402 is rotated toward the blade portion 420, the locking ball 418 is received in a cut-out 425 formed on the proximal surface 420b of the blade portion 420. As shown in FIG. 10c, the cut-out 425 slopes downward to adjoin the locking dimple 424 so that when the locking ball 418 is received, the slope of the cut-out 425 gradually pushes the locking ball 418 into the locking shaft 402h. Then, when the wedge 402 moves into alignment with the blade portion 420, the locking ball 418 extends out of the locking shaft 402h and enters the locking dimple 414 to couple the wedge 402 to the blade

portion 420 so that a rotation of the wedge 402 causes a corresponding rotation of the blade portion 420.

A radial length  $B_i$  between the peripheral edge 420e of the blade portion 420 and the actuating shaft 400 may substantially correspond to a radial length  $W_i$  between the wall 402f of the wedge portion 410 and the actuating shaft. This places the blade handle 408 in substantially the same position, relative to the cam surface 402c of the wedge portion 410, as in the previous embodiments. Of course, those skilled in the art will understand that it is important that the blade 408 should extend substantially distally to the blade slit 36 so that rotation of the blade portion 420 will cause a corresponding rotation of the blade 202 through the blade slit 36.

In operation, the wedge 402 is initially situated proximally of one of the blade housings, e.g., 74a while the blade portion 420 is situated proximally of the blade housing 74b with the blade 202 received in the blade housing 74b. When the lesion tissue has been drawn into position between the distal end 12a and the anvil member 10, the physician actuates the shaft 400 by applying a force at the control handle 6. This causes the wedge 402 to rotate to sequentially drive each of the staple drivers 472 distally through the corresponding staple slit 34. When the wedge 402 has rotated fully into alignment with the blade portion 420 and the locking ball 418 is received into the locking dimple 414, the operator then operates the control handle 6 in the opposite direction to draw the blade 202 out of the blade housing 74b to cut all of the tissue extending radially inward of the rows of staples. When the blade 202 is received in the other blade housing 74a, the wall of the body passage is released and the lesion tissue remains within the gap between the distal end 12a and the anvil member 10 held by the grasping devices 108. The lesion tissue may then be withdrawn from the body for analysis. This embodiment of the wedge 402 provides a safeguard in case the stapling process must be prematurely aborted due to, for example, a jam in one of the staple slits 34. Using this embodiment, the cutting process is not begun until all of the staples have been fired. Thus, it is possible to reduce the risk of cutting an opening in an organ which is not completely closed by the staples.

As shown in FIG. 5, the actuating mechanism 104 includes the actuating cable 450 which extends from a proximal end 450a coupled to the control handle 6 to a distal end 450b coupled to the proximal end 400a of the actuating shaft 400. Those skilled in the art will understand that the wedge 402 should preferably be situated towards the distal end 12a of the proximal housing 12 so that the yoke 103 does not interfere with rotation of the wedge 402 around the longitudinal axis of the actuating shaft 400 (discussed below) even when the yoke 103 is in its distal most position.

As shown in FIGS. 7-9a, the rear cover plate 460 may preferably be coupled to the proximal end 12b of the proximal housing 12. The proximal end 12b of the proximal housing 12 is then connected to the sheath 4. The actuating shaft 400 may preferably extend through a second shaft hole 464 formed in the rear cover plate 460 of the proximal housing 12 and preferably abuts an interior portion of the cavity 30 provided on the proximal housing 12. An endoscope hole 466 may preferably be provided on a portion of the rear cover plate 460 radially separated from the longitudinal axis of the working head assembly 2 to guide the endoscope 8 into the cut-out 29 of the proximal housing 12. The endoscope 8 may preferably be received into the endoscope hole 466 from an endoscope lumen 40 provided within the sheath 4 which is preferably disposed along a periphery of the sheath.

FIG. 9d shows a perspective cut-away view of the sheath 4 with the various devices (i.e., the two grasping devices 108, the drive cable 100, the actuating cable 450, and the endoscope 8) extending therethrough. Each of the various devices are further enclosed by one of a plurality of tubes 510 which allow either a rotational movement (for the cables 100, 450) or a longitudinal (for the two grasping devices 108 and the endoscope 8) movement therein. Similar to the sheath 4, the plurality of tubes extend from a proximal end coupled to the control handle 6, to a distal end coupled to the working head assembly 2. The plurality of tubes 510 provide protection against damage due to, for example, abrasion, and provide an isolated path through the sheath 4 which prevents tangling between the various devices.

FIG. 18 shows a cross-section of the control handle 6 which may be used in conjunction with a resectioning device of the invention. The control handle 6 may preferably be substantially "Y" shaped, with a first branch 500 for operating the actuating mechanism 104 and a second branch 502 for operating the drive mechanism 102 and a body 520. A receiving hole 512 runs longitudinally through the center of the body 520 for receiving the endoscope 8 therethrough. A first force transferring mechanism 504 is coupled to an actuating control knob 508, and extends axially through the first branch 500, through the body 520, where it is coupled to the actuating cable 450 which extends through the sheath 4 to connect to the actuating mechanism 104. A second force transferring mechanism 506 is coupled to a drive control knob 510, and extends axially through the second branch 502, through the body 520, where it is coupled to the drive cable 100 which extends through the sheath 4 to the drive mechanism 102. Those skilled in the art will understand that the control handle may be designed in any variety of shapes to accommodate, for example, different hand sizes, comfort, etc. In addition, different force transferring methods may also be used instead of a knob such as, for example, actuating levers, etc.

In operation, the user applies a rotational force to one of the control knobs 508 and 510, the rotational force is transferred through a respective one of the force transferring mechanisms 504 and 506 which then transfers rotational force to a respective one of the drive cable 100 and actuating cable 450, thereby operating the actuating mechanism 104 or the drive mechanism 102 as described above.

FIG. 11 shows a device according to a second embodiment of the present invention in which like reference numerals identify the same elements.

The anvil member 10 of this embodiment preferably has a substantially circular or elliptical cross-section and is gradually tapered from the proximal face 14 to its distal end 16, forming a bullet-like structure. This tapered shape allows the device to be more easily inserted into the patient's body as the distal end 16 has a smaller cross-sectional size than in the first embodiment. Those skilled in the art will understand that the anvil member 10 may have other tapered shapes besides a bullet-like structure without departing from the scope of the present invention.

Instead of providing the cut-out 13 shown in the first embodiment to receive the endoscope 8 therein, a substantially cylindrical first endoscope lumen 13 extends axially through the center of the anvil member 10. The distal end 16 of the anvil member 10 may preferably have a beveled edge 54 adjoining the first endoscope lumen 13 to allow for an expanded field of forward vision via the endoscope 8.

The proximal housing 12 may preferably have a cross-section corresponding in size and shape to the cross-section

of the proximal face 14 of the anvil member 10 (i.e., substantially circular or elliptical). In this embodiment, the cavity 30 in the first embodiment has been omitted and a substantially cylindrical second endoscope lumen 52 extends axially through the center of the proximal housing 12.

However, as in the previous embodiment, two grasper holes 32, 33 extend axially through the proximal housing. The two grasper holes 32 and 33 may preferably be disposed between the mounting holes 26a and 26b since the first endoscope lumen 13 now extends through the axial center of the proximal housing 12. In addition, the grasper holes 32, 33 in this embodiment may preferably have a substantially circular cross-section. However, those skilled in the art will understand that the cross-sectional shape of the grasper holes 32 and 33 may be selected to, for example, accommodate another type of device.

A receiving sleeve 55 is provided on the proximal end 12b of the proximal housing 12 for receiving the endoscope 8 and for guiding the endoscope 8 into the proximal housing 12. The receiving sleeve 55 may preferably have a first section 56 and a second section 58. The first section 56 and second section 58 may preferably both have an annular cross-section forming a continuous center hole 59 therethrough. The center hole 59 has a diameter which preferably corresponds to the diameter of the receiving hole 52 so that the endoscope 8 may be continuously received through the center hole 59 into the second endoscope lumen 52 in the proximal housing 12. The second section 58 preferably has a thicker wall than the first section 56, such that an annular ring formed by the cross-section of the second sections 58 has a larger width than an annular ring formed by the cross-section of the first section 56.

In contrast to the endoscope lumen 40 disposed along the periphery of the sheath 4 as shown in FIG. 1, the endoscope lumen 40 in this embodiment preferably runs along an axial center of the sheath 4, so that when the sheath 4 is coupled to the working head assembly 2, a substantially continuously aligned path is formed through the center hole 59, through the second endoscope lumen 52, and through the first endoscope lumen 13. The actuating shafts 400 and 105 and the drive cables 450 and 102 are then located concentric to the endoscope lumen 40 in the sheath 4.

FIG. 12 shows a device according to a third embodiment of the present invention. The proximal face 14 of the anvil member 10 of this embodiment has a cross-section similar to the crescent-shaped cross-section of the anvil member 10 of the device of FIG. 1. Thus, the anvil member 10 has two horns 22a and 22b formed on either side of a cut-out 13 which extends axially through the anvil member 10 from the proximal face 14 to the distal end 15 to receive the endoscope 8 therein. As with the device of FIG. 11, the cross-sectional size of the anvil member 10 diminishes in overall size from a maximum at the proximal face 14 to a minimum size at the distal end 15, and the horns 22a and 22b become less pronounced from the proximal face 14 to the distal end 15. In a side view, the anvil member 10 becomes gradually tapered from the proximal end 14 to the distal end 16.

As in the device of FIG. 11, the tapered shape of the anvil member 10 of the device of FIG. 12 allows for easier insertion of the device into the patient's body. In contrast to the second embodiment, the cut-out 13 provides a larger field of vision via the endoscope 8 as the anvil member does not totally enclose the cut-out 13. And, as in the first embodiment, two substantially cylindrical mounting shafts 20a and 20b are coupled to the proximal face 14 of the anvil

13

member **10** on horns **22a** and **22b** and are received within the mounting holes **26a** and **26b**, respectively.

In contrast to the previous embodiments, the proximal housing **12** in this embodiment may preferably have a substantially oval cross-sectional shape. This shape of the proximal housing **12** is formed by extending the proximal housing **12** shown in FIG. 1 around the cut-out **29** to create the substantially cylindrical second endoscope lumen **52**. The oval shape allows the second endoscope lumen **52** to be offset from the axial center of the proximal housing **12** and aligned with the first endoscope lumen **13**. This offset of the second lumen **52** allows the cavity **30** to be provided adjoining the blade slit **36**. In all other material respects, the proximal housing **12** in this embodiment is substantially identical to the proximal housing **12** illustrated in FIG. 1.

FIG. 13 shows a device according to a fourth embodiment of the present invention. This embodiment is substantially similar to the embodiment shown in FIG. 12. However, the proximal face **14** of the anvil member **10** in this embodiment has a substantially oval-shaped cross-section corresponding to the proximal housing **12**. The anvil member **10** is tapered towards the distal end **16** to form a substantially bullet-like structure having an oval-snaped cross-section. The cut-out **13** shown in FIG. 12 may preferably be enclosed within the anvil member **10** and thereby forms an extension of the first endoscope lumen **13**.

A substantially semicircular shield **31** extends from the proximal face **14** of the anvil member **10** and shields a hemispherical portion of the gap formed between the anvil member **10** and the proximal housing **12**. The shield **31** allows a tissue section to be drawn primarily in the gap between the staple-forming grooves **19** and the staple slits **34** with minimal spill-over into the rest of the gap.

A recessed groove **35** may preferably be formed around a portion of the proximal housing **12** for slidably receiving the shield **31** therein. The recessed groove **35** may preferably have a size and shape substantially corresponding to the size and shape of the shield **31** so that when the anvil member **10** is in its proximal most position, the shield **31** is received within the recessed groove **35** to form a substantially completely continuous outer surface of the proximal housing **12**.

In operation, the user may utilize suction through the endoscope **8** to draw a tissue section into the gap between the anvil member **10** and the proximal housing **12**. In such a situation, the shield **31** prevents a portion of the tissue section or loose debris from being pulled into the area around the mounting shafts **20a** and **20b** which may otherwise interfere with the axial movement of the mounting shafts **20a**, **20b**. In addition, the shield **31** also serves to direct the pulling force of the suction to pull tissue primarily in the gap between the staple-forming grooves **19** and the staple slits **34**.

FIGS. 14a and 14b show a device according to a fifth embodiment of the present invention in which the working head assembly **2** is coupled to the endoscope **8** without the sheath **4**. As described above, distal ends **500a** of control cables **500** (i.e., drive cable **100** and actuating cable **450**) may preferably be coupled to the -working head assembly **2** while proximal ends **500b** of the control cables **500** are coupled to the control handle **6** as in the previous embodiments. However, instead of using a flexible sheath **4** to receive the control cables **500** and the endoscope **8**, the control cables **500** are inserted into respective tubes **510**. Each of the tubes **510** should have a sufficient cross-section to allow the control cables **500** to rotate within the tubes **510**. The tubes **510** are then fastened at various predetermined

14

points along their lengths to the endoscope **8** by a plurality of fasteners **502**. Those skilled in the art will understand that many different types of fasteners may be used either alone or in combination for this purpose so long as the fasteners do not impede the steering of the endoscope **8** or the rotation of the cables **500**. Those skilled in the art will understand that tape (e.g., surgical, electrical, etc.), electrical cable, rubber bands, other belt-style fasteners, etc. may be used as fasteners.

FIGS. 16–18 illustrate alternative configurations of the blade housing **74b** and it will be understood that similar alternative embodiments may be implemented for the blade housing **74a**.

The blade slit **36** continues through the blade housing **74b** into housing portion **84b** which extends from a forward end at which the blade slit **36** enters the blade housing **74b** to a rearward end where the blade slit **36** and the housing portion **84b** terminate. A shield receiving slit **480** extends through the blade housing **74b** substantially perpendicular to the housing portion **84b** between the forward and rearward ends thereof.

After an organ section has been stapled between the anvil member **10** and the proximal housing **12**, and the blade **202** is drawn through the stapled tissue, there may be a problem if tissue stretches along with the blade **202** into the housing portion **84b** without being completely severed. Withdrawal of the resected tissue might then lead to tearing of the tissue which is to remain in place.

As seen in FIG. 17, a flexible breakaway shield **482** having a shape and size substantially corresponding to the shape and size of the shield receiving slit **480** is inserted into the shield receiving slit **480**. After entering the housing portion **84b**, the cutting blade **202** contacts the shield **482** and further progress of the blade **202** deforms the shield **482** until the shield **482** is cut in half. When the shield **482** is cut in half, each half snaps back pulling the tissue in a direction opposite the direction of travel of the blade allowing the cutting blade **202** to completely sever the tissue.

FIG. 18 shows a second alternative arrangement in which a flexible gate **484**, having a first gate half **484a** and a second gate half **484b**, may be removably or fixedly mounted within the shield receiving slit **480**. Each of the halves **484a** and **484b** may preferably be mounted within a respective half of the shield receiving slit **480**, so that a small gap formed therebetween substantially corresponds in width to the width of the cutting blade **202**. The wiping action in a direction opposed to the direction of travel of the blade **202** is substantially the same as that of the shield **482** without requiring the severing and replacement of the shield **482** after each use.

FIGS. 19a and 19b show a third alternative arrangement in which a pair of tissue blockers **600** and **602** facilitate the cutting of the resected tissue. Although, the following discussion will focus on the first tissue blocker **600**, those skilled in the art will understand that a similar arrangement may be provided on the second tissue blocker **602**.

As shown in FIG. 19a, the first tissue blocker **600** is composed of a first rectangular bar **610** and a second rectangular bar **612** situated at a first end **21a** of the guiding slit **21**. The first rectangular bar **610** has a first base **610a** and the second rectangular bar **612** has a second base **612a**, which are both fixedly coupled to the proximal face **14** of the anvil member **10** and arranged so that the bases **610a**, **612b** straddle both sides of the guiding slit **21** with a gap formed therebetween corresponding to the width of the guiding slit **21**.

15

A first slot **614a** is provided in the first base **610a** of the first rectangular bar **610**, and a second slot **614b** is provided in the second base **612a** of the second rectangular bar **612** so that when the rectangular bars **610**, **612** are coupled to the anvil member **10**, the flexible breakaway shield **482** (shown in FIG. 17) may be disposed within the slots **614a**, **614b**. As shown in FIG. 19c, a pair of L-shaped holes **620**, **622** are provided on both ends of the blade slit **30** on the distal end **12a** of the proximal housing **12**. The L-shaped holes **620**, **622** extend longitudinally within the proximal housing **12** to receive the rectangular bars **610**, **612** therein when the anvil member **10** is coupled to the proximal housing **12**.

This arrangement operates similarly to the arrangement shown in FIG. 17, so that the wiping action of the shield **482** in a direction opposite to a movement of the blade **202** allows the blade **202** to completely cut through the resected tissue. Although the shield **482** is initially a single piece in a first operation of the device, the shield **482** may be re-used without replacement in further operations with minimal diminishment of its effectiveness.

FIG. 20 shows a device according to a sixth embodiment of the present invention in which like reference numerals identify the same elements. The sheath **4** is substantially more rigid and shorter than in previous embodiments. Although this decreases the effective operative range of the device, the rigidity of the sheath **4** increases its overall structural strength, allowing greater forces to be transferred therethrough to the working head assembly **2** than in the previous embodiments. The cables **100**, **450** driving the various mechanisms **102**, **104** may then need to be stronger and stiffer in order to accommodate the increased forces. As a result of these changes, the overall size of the working head assembly **2** may then be increased to, for example, treat lesions that may be too large for the devices according to the previous embodiments to treat in a single procedure.

FIGS. 21–25 show a device according to a seventh embodiment of the present invention in which the working head assembly **2** comprises the anvil member **10**, a stapler member **17**, and a connecting adapter **25**. As shown in FIG. 21, the anvil member **10** and the stapler member **17** preferably have substantially semi-circular shapes complementary to one another such that, when they are positioned adjacent to each other, they form a substantially annular clamp-like device (as shown in FIG. 23). The anvil member **10** and the stapler member **17** are pivotally connected via a substantially cylindrical hinge-pin **60** which is provided on a distal end **25a** of the connecting adapter **25**. A proximal end **25b** of the connecting adapter **25** may preferably be coupled to the sheath **4** in a manner similar to that in which the proximal housing **12** is connected to the sheath **4** in the previous embodiments. Those skilled in the art will understand that the shape of the anvil member **10** and the stapler member **17** may be modified to accommodate specific needs or applications without departing from the scope of the present invention.

As shown in FIG. 22, a plurality of first ring-like extensions **10b** are formed on a first end **10a** of the anvil member **10**. The first extensions **10b** may preferably be separated a predetermined distance from one another to form a plurality of spaces in which a corresponding plurality of second ring-like extensions **17b** formed on a first end **17a** of the stapler member **17** are accommodated. The first extensions **10b** may substantially correspond in shape and size to the second ring-like extensions **17b** so that when the first anvil end **10a** and the first stapler end **17a** are engaged, an alternating arrangement of first and second extensions **10b**, **17b** is formed in which the holes of each of the first and

16

second extensions **10b**, **17b** are substantially aligned to form a continuous hole in which a hinge-pin **60** is received. Thus, the hinge-pin **60** and the first and second extensions **10b**, **17b** form a hinge which allows the anvil member **10** and the stapler member **17** to pivot about the hinge-pin **60**. A locking ring **62** may preferably be attached to a distal end **61** of the hinge-pin **60** to secure the first and second extensions **10b**, **17b** to the hinge-pin **60**.

A first anchoring joint **23a** is formed on an interior face **10i** of the anvil member **10**. The first anchoring joint **23a** may preferably have a substantially triangular cross-section viewed along the longitudinal axis of the working head assembly **2**. However, a side of the first anchoring joint **23a** that is attached to the anvil member **10** may preferably be convex in shape complementary to the concave shape of the interior face **10i** of the anvil member **10**. A substantially similar second anchoring joint **23b** is formed on an interior face **17i** of the stapler member **17** having a size and shape corresponding to the size and shape of the anchoring joint **23a**.

As shown in FIG. 23, first and second coupling elements **64a**, **64b** are disposed on respective anchoring joints **23a**, **23b** to couple the anchoring joints **23a**, **23b** to two rod links **150a**, **150b**, respectively. The rod links **150a**, **150b** provide a rigid coupling between the anchoring joints **23a**, **23b** and a distal end **154** of a push rod **152**. Thus, a longitudinal force in a distal or proximal direction applied to the push rod **152** is transferred to the anchoring joints **23a**, **23b**, and thereby to the anvil member **10** and the stapler member **17**.

In operation, when a distally directed pushing force is applied to the push rod **152**, the force is transferred through the link rods **150a**, **150b** to the anvil member **10** and the stapler member **17** via the respective anchoring joints **23a**, **23b**, gradually separating an anvil head **10c** on the anvil member **10** from a stapler head **17c** on the stapler member **17** until they reach a tissue receiving position. Similarly, when a proximally directed pulling force is applied to the push rod **152**, the anvil head **10c** and the stapler head **17c** are drawn toward one another until they reach a stapling position, in which the anvil head **10c** and the stapler head **17c** are adjacent to one another separated by a narrow gap. As the anvil head **10c** and the stapler head **17c** are drawn together by the push rod **152**, a stabilizer tongue **308** extending from the stapler head **17c** of the stapler member **17** is gradually received within a stabilizing groove **304** on the anvil head **10c**. This tongue/groove arrangement provides a guide and a securing/stabilization mechanism for the anvil member **10** and the stapling member **17**.

The anvil head **10c** is disposed on a second end **10e** of the anvil member **10** that is opposite to the first end **10a** thereof. The anvil head **10c** may preferably have a substantially rectangular cross-section larger than a cross-sectional size of the rest of the anvil member **10**.

The anvil head **10c** has an anvil face **10d** on which a plurality of staple-forming grooves **19** may preferably be arranged in two offset, substantially straight lines. In addition, a substantially straight guiding slit **21** may preferably extend substantially along the center of the anvil face **10d**, substantially parallel to the lines of staple-forming grooves **19**, while the stabilizing groove **304** is preferably formed along a distal side of the anvil face **10d** for receiving the stabilizer tongue **308**. The stabilizing groove **304** may preferably have a shape and size substantially corresponding to the stabilizing tongue **308** so that the stabilizing tongue **308** is snugly received within the stabilizing groove **304** when the anvil member **10** and the stapler member **17** are in the stapling position.

As shown in FIG. 23a, the stapler head 17c is formed on a second end 17e of the stapler member 17 opposite to the first end 17a thereof, and preferably has a cross-section corresponding, at least in the area adjacent to a stapler face 17d, to the size and shape of the anvil head 10c. A plurality of staple slits 34 are arranged on the stapler face 17d in positions corresponding to the position of the staple-forming grooves 19 on the anvil head 10c so that when the stapler face 17d and anvil face 10d are positioned adjacent to each other, each of the plurality of staple slits 34 is substantially aligned with a corresponding one of the plurality of staple-forming groove 19. Additionally, a substantially straight blade slit 36 extends across the stapler face 17d corresponding to the guiding slit 21 on the anvil head 10c so that when the stapler head 17c and the anvil head 10c are positioned adjacent to one another, the blade slit 36 is substantially aligned with the guiding slit 21.

As shown in FIG. 23, the distal end 25a of the connecting adapter 25 preferably has a cross-section corresponding to the shape and size of the peripheral surface of the annular clamp-like shape formed by the anvil member 10 and the stapler member 17 so that a substantially smooth, continuous outer surface is formed by the anvil member 10, the stapler member 17, and the connecting adapter 25 when the anvil member 10 and the stapler member 17 are in the stapling position. The connecting adapter 25 is preferably gradually tapered from the distal end 25a to the proximal end 25b thereof, and the proximal end 25b may then be coupled to the sheath 4 as shown in FIG. 24. As further shown in FIG. 24, a substantially cylindrical endoscope lumen 52 preferably extends axially through the center of the connecting adapter 25 for receiving a conventional endoscope 8 therethrough. The connecting adapter 25 may also have a substantially cylindrical rod hole 322 extending axially along the periphery of the connecting adapter 25 extending through an area adjacent to the hinge-pin 60, for receiving the push rod 152 therein.

As shown in the cut-away view of FIG. 25, a track 350 is provided within the stapler head 17c extending within the stapler head 17c from an area adjacent to a distal end 352 of the stapler head 17c to an area adjacent to a proximal end 354 thereof. FIG. 26 shows a cutaway view of the stapler head 17c showing the track 350 having a substantially L-shaped cross-section. The track 350 may preferably be situated so that a first leg 350a of the track 350 extends substantially beneath the plurality of staple slits 34 on the staple face 17d, and a second leg 350b of the track 350 extends substantially beneath the blade slit 21 on the staple face 17d.

In a first configuration shown in FIG. 25, a wedgesled 402 is provided (instead of the wedge 402 described in the previous embodiments) on a distal end 350a of the track 350. The wedge-sled 402 has a cut-out in a corner forming a cam surface 412 thereon and a blade handle 408. This provides the wedge-sled 402 with a substantially L-shaped cross-section substantially corresponding to the cross-sectional shape of the track 350. The wedge-sled 402 is arranged in the track 350 so that the cam surface 412 is substantially disposed in the first leg 350a of the track facing toward the plurality of staple slits 34. Furthermore, the wedge-sled 402 is arranged in the track 350 so that the blade handle 408 is substantially disposed in the second leg 350b beneath the blade slit 21. Thus, when the cutting blade 202 is coupled to the blade handle 408, the cutting blade 202 extends out of the blade slit 21 as in the previous embodiments. As shown in FIG. 26, the stabilizing tongue 308 has a receiving slit 309 for receiving the cutting blade 202

therein when the wedge-sled 402 is positioned at the distal end 350a of the track 350. This prevents unintentional cutting of tissue as the device is inserted and guided within the organ.

As shown in FIG. 25, an actuating cable 450 for operating the stapler head 17c is coupled to the leading edge 402d of the wedge-sled 402 and extends through the track 350, through a tube 332 (which is coupled to the proximal end 354 of the stapler head 17c and extends through the sheath 4 to the control handle) of the plurality of tubes 510 (shown in FIG. 9d), and is then coupled to the control handle 6 (not shown).

In operation, the wedge-sled 402 is initially positioned at the distal end 350a of the track 350 with the blade 202 received within the receiving slit 309 of the stabilizing tongue 308 as the operator maneuvers the device to a desired location within the body. While the device is being maneuvered to the desired location, the anvil member 10 and the stapler member 17 are located adjacent to each other in the stapling position. When the desired position is reached, the operator pushes the push rod 152 distally to separate the anvil member 10 and the stapler member 17 into the tissue receiving position. Then the operator draws the portion of tissue to be resected into the gap between the stapler member 17 and the anvil member 10 and draws the push rod 152 proximally to return the anvil member 10 and the stapler member 17 to the stapling position, gripping the tissue to be resected within the gap. The operator then pulls actuating cable 450 proximally, drawing the wedge-sled 402 towards the proximal end 350b of the track 350. As the cam surface 412 on the wedge-sled passes beneath each one of the plurality of staple slits 34, the cam surface 412 drives each one of a plurality of staple drivers 472 (each being disposed within a corresponding one of the staple slits 34) sequentially driving a plurality of staples out of the staple slits 34 to staple the tissue gripped between the anvil head 10c and the stapler head 17c. In addition, the cutting blade 202 coupled to the blade handle 408 of the wedge-sled 402 is pulled through the blade slit 21 to resection the tissue which has now been stapled off from the organ.

When the tissue has been resected, the operator pushes the operating cable 450 distally to return the cutting blade 202 to the receiving slit 309 of the stabilizing wedge 308. The device may then be withdrawn from the body.

As shown in FIGS. 23 and 25, the anvil member 10 and the stapler member 17 have a tissue receiving position shown in FIG. 25, and a stapling position shown in FIG. 23. Therefore, it is necessary to allow the actuating cable 450 disposed within the tube 332 and received within the stapler head 17c to correspondingly move with the stapler member 17. Accordingly, a channel 330 is provided in the connecting adapter 25 to receive the tube 332 therein. The channel 330 may preferably be formed within the connecting adapter 25 to substantially correspond to the arc path along which the tube 332 is pulled by the stapler member 17, as the stapler member 17 moves between the tissue receiving and the stapling positions. Thus, the channel minimizes bending and crimping of the tube 332.

Those skilled in the art will understand that although the proximal housing 12 in any of the embodiments may preferably be composed of a metallic-type material, the proximal housing 12 may also be composed of a clear plastic-type material which would allow the user to operate the working head assembly 2 under visual observation by partially withdrawing the endoscope 8 into the second endoscope lumen 52 in the proximal housing 12. The user could then look

through the walls of the endoscope lumen 52 into the proximal housing 12 to, for example, observe whether each of the plurality of staple drivers 472 have been actuated. In addition, the user may also observe whether the wedge 402 shown in FIGS. 10a and 10b is locked into the blade portion 420 as described above. Alternatively, selected portions of the proximal housing 12 may be composed of the clear plastic-type material providing a "window" to view through the proximal housing 12.

Those skilled in the art will also understand that although the above-described embodiments show mechanical force transmission between the control handle and the working head assembly, this device could alternatively include an electronic control for receiving input from an operator coupled to a series of motors in the working head assembly. Those skilled in the art will further understand that the relative positioning of the stapling mechanisms and the position adjusting mechanisms to each other may be reversed, placing the stapling mechanisms in a distal-most position in relation to the position adjusting mechanism. The above described embodiments are for purposes of illustration only and the various modifications of these embodiments which will be apparent are considered to be within the scope of the teachings of this invention which is to be limited only by the claims appended hereto.

What is claimed is:

1. A full-thickness resection system for removing a full-thickness portion of a body organ, the system comprising:
  - a flexible endoscope;
  - a stapling mechanism which, in an operative position is located within a body of a patient, wherein the endoscope is slidably received through at least a portion of the stapling mechanism, the stapling mechanism comprising:
    - an anvil;
    - a stapling head coupled to the anvil so that the anvil and the stapling head are moveable with respect to one another along an axis substantially parallel to a longitudinal axis of the stapling mechanism between a tissue receiving position and a stapling position, wherein a gap formed between the stapling head and the anvil is larger in the tissue receiving position than in the stapling position;
    - a position adjusting mechanism for moving at least one of the anvil and the stapling head relative to the other of the anvil and the stapling head between the tissue receiving and stapling positions;
    - a staple firing mechanism for sequentially firing, when the stapling head and the anvil are in the stapling position, staples received in the stapling head from the stapling head across the gap against the anvil and through any tissue received in the gap; and
    - a knife operable independently of the staple firing mechanism to cut a portion of tissue received within the gap; and
  - a control unit which, when the stapling head is in the operative position, remains outside the body, the control unit being coupled to the stapling mechanism for controlling operation of the position adjusting mechanism and the staple firing mechanism.
2. The full-thickness resectioning system according to claim 1, wherein the control unit includes a rotatable control member coupled to the stapling mechanism by at least one longitudinally flexible, torsionally stiff drive shaft.
3. The full-thickness resectioning system according to claim 1, wherein the stapling head is formed in a proximal housing and includes a plurality of staple slits formed on a

distal face thereof and wherein the anvil includes a plurality of staple forming grooves formed on a proximal surface thereof and wherein, when in the stapling position, the staple forming grooves face the staple slits across the gap.

4. The full-thickness resectioning system according to claim 3, wherein the anvil is permanently coupled to the staple head.

5. The full-thickness resectioning system according to claim 3, wherein the staple firing mechanism includes a plurality of staple firing members, each staple firing member being slidably received in a respective one of the staple slits.

6. The full-thickness resectioning system according to claim 5, wherein the control unit further includes a rotatable control member coupled to the stapling mechanism by at least one longitudinally flexible, torsionally stiff drive shaft, the staple slits and the staple forming grooves extending around a portion of a first circle and wherein the staple firing mechanism includes a wedge non-rotatably coupled to the drive shaft for rotation with the drive shaft in a plane adjacent to proximal ends of the staple firing members.

7. The full-thickness resectioning system according to claim 6, wherein the knife cuts tissue along a portion of a second circle concentric with the first circle, a radius of the second circle being smaller than a radius of the first circle.

8. The full-thickness resectioning system according to claim 7, wherein the wedge is rigidly coupled to the knife.

9. The full-thickness resectioning system according to claim 7, wherein the knife is rotatably coupled to the drive shaft so that the drive shaft may rotate independently of the knife and wherein the wedge is selectively coupleable to the knife so that, when coupled to the wedge, the knife is rigidly coupled to the wedge for rotation with the drive shaft and the wedge.

10. The full-thickness resectioning system according to claim 6, wherein the staple slits extend around a portion of the first circle less than 360°.

11. The full-thickness resectioning system according to claim 6, wherein the staple slits extend around a portion of the first circle less than 270°.

12. The full-thickness resectioning system according to claim 6, wherein the first circle extends in a plane substantially perpendicular to the longitudinal axis of the stapling mechanism.

13. The full-thickness resectioning system according to claim 6, wherein the knife cuts tissue along a portion of a second circle concentric with the first circle, a radius of the second circle being smaller than a radius of the first circle.

14. The full-thickness resectioning system according to claim 3, wherein at least a portion of the proximal housing is composed of a substantially clear rigid material.

15. The full-thickness resectioning system according to claim 1, wherein a distal surface of the anvil forms a distal most end of the stapling mechanism which, on insertion into the body organ, forms a leading surface thereof and wherein the distal surface of the anvil is tapered.

16. The full-thickness resectioning system according to claim 1, wherein the control unit is selectively coupleable to the knife so that operation of the control unit controls the knife independently of operation of the stapling mechanism.

17. The full-thickness resectioning system according to claim 1, wherein the stapling head includes at least one lumen extending therethrough for receiving a grasper device.

18. The full-thickness resectioning system according to claim 1, wherein the anvil is pivotally coupled to the staple head.

19. The full-thickness resectioning system according to claim 1, further comprising a flexible blade shield cooper-

ating with the knife to cut through the portion of the tissue received within the gap.

20. The full-thickness resectioning system according to claim 19, wherein, when moving between an initial pre-cutting position and a final post-cutting position, the knife cuts the flexible blade shield.

21. The full -thickness resectioning system according to claim 19, wherein the flexible blade shield includes a first portion and a second portion, and wherein, when moving between an initial pre-cutting position and a final post-cutting position, the knife passes between the first and second portions of the flexible blade shield.

22. A method of performing a full-thickness resection of tissue within a substantially tubular body organ comprising the steps of:

inserting a stapling mechanism slidably received around a flexible endoscope into a tubular body organ via a body orifice, wherein the stapling mechanism includes a stapling head and an anvil coupled to one another for movement along an axis substantially parallel to a longitudinal axis of the stapling mechanism between a stapling position and a tissue receiving position, wherein a gap formed between the stapling head and the anvil is smaller in the stapling position than in the tissue receiving position, the stapling mechanism further includes a knife movably mounted therein;

advancing the stapling mechanism along the endoscope to a portion of wall tissue of the body organ to be resectioned;

moving the stapling mechanism into the tissue receiving position;

drawing the portion of the wall tissue into the gap;

moving the stapling mechanism into the stapling position; firing a plurality of staples through the tissue received in the gap, wherein the portion of wall tissue into which the staples are fired extends around a longitudinal axis of the body organ by an angle of less than 360°;

after staple firing has been completed, operating the knife to cut away from the wall of the body organ the portion of tissue to be resectioned.

23. The method according to claim 22, wherein the stapling mechanism is coupled to a controller by at least one torsionally rigid, longitudinally flexible drive shaft, wherein the controller remains outside the body.

24. The method according to claim 23, wherein a longitudinally flexible sheath surrounds the endoscope and the drive shaft.

25. The method according to claim 22, wherein the entire resectioning procedure is performed endoluminally.

26. The method according to claim 25, wherein the stapling mechanism is maneuvered into a desired position adjacent to the tissue to be resectioned by steering the flexible endoscope through the body organ to locate the tissue to be resectioned visually and then sliding the stapling mechanism along the endoscope to the desired position.

27. The method according to claim 22, the stapling mechanism being coupled to a controller which, during operation of the stapling mechanism, remains outside the body of the patient, wherein the step of cutting away the portion of tissue to be resectioned includes the sub-steps of:

confirming that the staples have been properly fired into desired locations in the tissue of the body organ;

engaging the knife with the controller; and

operating the controller to draw the knife through the tissue of the body organ to sever the tissue to be resectioned.

28. The method according to claim 27, the controller and the stapling mechanism being coupled together by a torsionally rigid, longitudinally flexible drive shaft wherein, in a first configuration, the knife is disengaged from the drive shaft so that rotation of the drive shaft does not move the knife from an initial position and wherein in a second configuration, the knife is engaged with the drive shaft so that rotation of the drive shaft moves the knife between the initial position and a final position severing the portion of tissue received within the gap.

29. The method according to claim 27, wherein the tissue to be resectioned is drawn into the gap by a grasper device inserted into the gap via a first lumen extending through the stapling mechanism.

30. The method according to claim 29, wherein the grasper device is inserted into the gap via a second lumen extending through a flexible endoscope received within the first lumen.

31. A full-thickness resection device comprising:

a stapling mechanism having an endoscope receiving lumen extending therethrough, wherein, in an operative position, the stapling mechanism is entirely received within a body of a patient, the stapling mechanism comprising:

an anvil;

a stapling head coupled to the anvil so that the anvil and the stapling head are moveable with respect to one another along an axis substantially parallel to a longitudinal axis of the stapling mechanism between a tissue receiving position and a stapling position, wherein a gap formed between the stapling head and the anvil is larger in the tissue receiving position than in the stapling position;

a gear drive for moving at least one of the anvil and the stapling head relative to the other of the anvil and the stapling head between the tissue receiving and stapling positions;

a moveable cam, motion of which past a plurality of firing pins sequentially fires staples, received in the stapling head adjacent to the firing pins, from the stapling head across the gap against the anvil and through any tissue received in the gap; and

a knife for cutting a portion of tissue received within the gap;

a control unit which, when the stapling head is in the operative position, remains outside the body, the control unit being coupled to the stapling mechanism via at least one flexible drive shaft for controlling operation of the position adjusting mechanism, the staple firing mechanism and the knife wherein, in a cutting configuration, the knife is non-rotatably coupled to the drive shaft so that rotation of the drive shaft moves the knife through the gap and in a non-cutting configuration, rotation of the drive shaft does not move the knife through the gap.

UNITED STATES PATENT AND TRADEMARK OFFICE  
**CERTIFICATE OF CORRECTION**

PATENT NO. : 6,343,731 B1  
APPLICATION NO. : 09/813944  
DATED : February 5, 2002  
INVENTOR(S) : Adams et al.

Page 1 of 1

It is certified that error appears in the above-identified patent and that said Letters Patent is hereby corrected as shown below:

Title Page item [63]

Related U.S. Application Data section should be replaced with the following:

--Continuation of U.S. Patent Application Serial No. 09/694,894, now U.S. Patent No. 6,241,140, which is a continuation of U.S. Patent Application Serial No. 09/316,674, now U.S. Patent No. 6,179,195, which is a divisional of U.S. Patent Application Serial No. 09/100,393, now U.S. Patent No. 6,126,058.--

Col. 1, lines 5-7 should be replaced with the following:

--This application is a continuation of U.S. Patent Application Serial No. 09/694,894, now U.S. Patent No. 6,241,140, which is a continuation of U.S. Patent Application Serial No. 09/316,674, now U.S. Patent No. 6,179,195, which is a divisional of U.S. Patent Application Serial No. 09/100,393, now U.S. Patent No. 6,126,058.--

Signed and Sealed this

Sixth Day of April, 2010

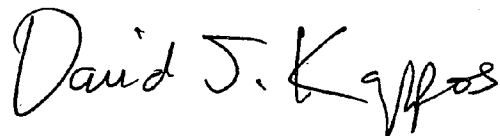

David J. Kappos  
*Director of the United States Patent and Trademark Office*