

(19)



Europäisches Patentamt
European Patent Office
Office européen des brevets



(11)

EP 0 606 907 B1

(12)

EUROPEAN PATENT SPECIFICATION

(45) Date of publication and mention
of the grant of the patent:
21.04.1999 Bulletin 1999/16

(51) Int Cl.⁶: **G03G 15/02**

(21) Application number: **94100436.8**

(22) Date of filing: **13.01.1994**

(54) Charging roller for an image forming apparatus

Aufladerolle für ein Bilderzeugungsgerät

Rouleau de chargement pour un appareil de formation d'images

(84) Designated Contracting States:
DE ES FR GB IT

(30) Priority: **13.01.1993 JP 3675/93**
28.10.1993 JP 270590/93

(43) Date of publication of application:
20.07.1994 Bulletin 1994/29

(60) Divisional application: **97107365.5 / 0 810 486**

(73) Proprietor: **Ricoh Company, Ltd**
Ohta-ku Tokyo 143 (JP)

(72) Inventor: **Nojima, Kazuo**
Chiba-shi, Chiba-ken (JP)

(74) Representative: **Schwabe - Sandmair - Marx**
Stuntzstrasse 16
81677 München (DE)

(56) References cited:
EP-A- 0 406 834 **EP-A- 0 417 801**
EP-A- 0 510 643 **US-A- 4 727 453**

- **DATABASE WPI Week 9251, Derwent Publications Ltd., London, GB; AN 92-418341 & JP-A-4 311 972 (RICOH KK) 4 November 1992**

Remarks:

Divisional application 97107365.5 filed on 05/05/97.

EP 0 606 907 B1

Note: Within nine months from the publication of the mention of the grant of the European patent, any person may give notice to the European Patent Office of opposition to the European patent granted. Notice of opposition shall be filed in a written reasoned statement. It shall not be deemed to have been filed until the opposition fee has been paid. (Art. 99(1) European Patent Convention).

Description

[0001] The present invention relates to a charging roller as defined in the preamble of claim 1, i.e. according to EP-A-0 406 834, for a copier, printer, facsimile transceiver or similar image forming apparatus and, more particularly, to a charging roller for uniformly charging the surface of a photoconductive element, or image carrier, during a sequence of image forming steps.

[0002] It has been customary with an image forming apparatus of the type described to use a corona discharger as charging means for uniformly charging the surface of a photoconductive element. A corona discharger effectively charges the surface of a photoconductive element uniformly to a predetermined potential. However, the problem is that a corona discharger needs a high tension power source and generates ozone during discharge. Ozone generated in a great amount would not only pollute the environment but also aggravate the deterioration of a charging member as well as the photoconductive element.

[0003] In the light of this, there has been proposed a charging device using a charging roller in place of the corona discharger. This type of charging device has a charging roller held in contact with and driven by a photoconductive drum. The charging roller has a metallic core. As a voltage is applied from a power source to the core of the charging roller, the roller charges the surface of the drum. With the charging roller, it is possible to lower the required voltage of the power source and to reduce the amount of ozone ascribable to charging. In addition, the charging roller prevents dust particles from electrostatically depositing on a corona wire and eliminates the need for a high tension power source. However, the problem with this type of charger is that the charge distribution is apt to become irregular and, in addition, the charge potential is extremely susceptible to the environment. In fact, such a charger is far inferior to a charger of the type using a corona discharger in respect of the uniformity of charge distribution.

[0004] Japanese Patent Laid-Open Publication JP-A-63-149668 teaches that the uniformity of charge is noticeably improved when an AC voltage having a peak-to-peak voltage more than twice as high as a charge start voltage (V_{TH}) is superposed in the event of application of a DC voltage. However, this kind of scheme needs an AC power source in addition to a DC power source for superposing the AC voltage on the DC voltage, increasing the cost of the apparatus. Moreover, since a great amount of AC current not contributing to the charge potential of the photoconductive element is wastefully consumed. This not only increases the running cost of the apparatus but also generates a great amount of ozone, bringing about the previously stated critical problems.

[0005] EP-A-0 406 834 refers to a charging member including a base layer and a surface layer. The base layer has a resistivity of 10^0 to 10^{11} Ω .cm. The surface layer includes 30% by wt. or higher and more preferably 50% by wt. or higher polyurethane resin, which is made of an isocyanate group and a hydroxyl group and particular care is involved to satisfy a relationship between the two ingredients of the polyurethane. The volume resistivity of the surface layer is adjusted to be within the range of 10^6 Ω .cm to 10^{12} Ω .cm.

[0006] From DATABASE WPI, Week 9251, Derwent Publications Ltd., AN 92-418341 and JP-A-4 311 972, an electrically conductive elastic layer and a resistance layer on an electrically conductive base are arranged to provide a charging roller for charging a photoconductive element. The conductive elastic layer has a resistivity of about 10^1 to 10^5 Ω .cm and the surface layer has a resistivity of about 10^6 Ω .cm to 10^{12} Ω .cm. Since this elastic layer is conductive, a relatively thick surface layer is necessary to avoid short circuiting between the elastic layer and a body to be charged, because the thickness of the surface layer influences the characteristics of the surface layer against breakdown between the elastic layer and a body to be charged much more than the resistance of the surface layer.

[0007] It is, therefore, an object of the present invention to provide a charging roller for an image forming apparatus capable of reducing the cost of the apparatus itself, power source cost, and generation of ozone to thereby prevent a charging member and a photoconductive element from deteriorating and avoid environmental pollution.

[0008] It is another object of the present invention to provide a charging roller for an image forming apparatus which, with a simple construction, insure attractive images at all times with no regard to the varying environment.

[0009] A charging roller for charging a photoconductive element included in an image forming apparatus of the present invention comprises the features set forth in claim 1.

[0010] Embodiments of the present invention are defined by the subclaims.

[0011] The above and other objects, features and advantages of the present invention will become more apparent from the following detailed description taken with the accompanying drawings in which:

FIG. 1 is a vertical section of a charging device implemented with a charging roller embodying the present invention; and

FIGS. 2 and 3 are vertical sections each showing a charging device having a particular conventional charging roller.

[0012] To better understand the present invention, a brief reference will be made to a charging device having a conventional charging roller, shown in FIG. 2. As shown, the charging device 1, generally 1, has a charging roller 2 held in contact with an image carrier implemented as a photoconductive drum 3 by way of example. While the charging

roller 2 is in rotation, a high-tension DC voltage is applied from a DC power source 7 to the roller 2 to cause it to charge the drum 3. The charge roller 2 is made up of a metallic core 4, a conductive elastic layer 15 formed on the core 4 and having NBR or conductive particles dispersed therein, and a fluorine-based non-adhering film 10 provided with conductivity. The problem with this kind of charge roller 2 is that irregularity in electric characteristic is so great, the charge deposited on the drum 3 via the conductive elastic layer 15 is irregular. As a result, the background of an image is contaminated at a period coincident with the roller period.

[0013] FIG. 3 shows a charging device using another conventional charging roller elaborated to eliminate the above problem. In the figure, the same or similar constituent parts as or to the parts shown in FIG. 2 are designated by the same reference numerals, and a detailed description thereof will not be made in order to avoid redundancy. As shown, the charging roller 2 has an elastic layer 25 formed on the metallic core 4 and made of, for example, NBR, urethane or EPDM. A surface layer 11 is formed on the elastic layer 25 and has a conductive substance dispersed therein. The surface layer 11 is held in contact with the core 4. The DC power source 7 applies an AC-biased DC voltage to the core 4. In this configuration, to charge the drum 3 uniformly, the AC voltage biasing the DC voltage is provided with a peak-to-peak voltage twice as high as a charge start voltage to occur at the time when the DC voltage is applied. However, even this type of charging roller 2 is disadvantageous in that an AC power source 8 is necessary in addition to the DC power source 7 and results in an extra cost, in that a great amount of AC current which does not contribute to the charge potential of the drum 3 is wastefully consumed, and in that the AC current generates harmful ozone, as discussed earlier.

[0014] Referring to FIG. 1, a charging roller embodying the present invention and a charging device implemented therewith will be described which are free from the above-described problems. In the figure, the same or similar constituent parts as or to the parts shown in FIGS. 2 and 3 are designated by the same reference numerals, and a detailed description thereof will not be made in order to avoid redundancy. As shown, a charging roller 2 has a metallic core 4, an elastic layer 5 formed on the core 4, and a surface layer 6 formed on the elastic layer 5. A DC power source 7 applies a high-tension negative DC voltage of 1.3 kV to 1.6 kV to cause it to charge a photoconductive drum 3. The elastic layer 5 is made of epichlorohydrin rubber having a medium electric resistance and in which conductive particles are not dispersed. The epichlorohydrin rubber may be implemented by a binary copolymer of epichlorohydrin-ethylene oxide or a ternary copolymer of epichlorohydrin-ethylene oxide arylglycidyl ether.

[0015] The surface layer 6 is constituted by a mixture of epichlorohydrin rubber applied to the elastic layer 5 and non-adhering fluorine-based resin. This is to enhance the non-adhering property of the surface of the charging roller 2 against the deposition of toner particles. The fluorine-based resin is an amorphous polymer soluble to a solvent and produced by the copolymerization reaction of fluoroolefin and hydrocarbon-based vinyl ether. For details of this kind of resin, a reference may be made to Kojima et al "Journal of the Institute of Organic Synthetic Chemical Engineers of Japan", Vol. 42 (7), page 841, 1984 and Munakata et al "Asahi Glass Study Report (Japan)", Vol. 34 (2), pages 205-224, 1984. The fluorine-based resin has a relatively low fluorine content, i.e., 25 wt% to 32 wt%. However, since the resin of this kind is an alternating copolymer in which fluoroolefin and hydrocarbon vinyl ether alternate with each other, the fluoroolefin portions which are thermochemically stable and regularly arranged protect the unstable hydrocarbon-based vinyl ether portions electronically and sterically. Hence, such a resin is chemically stable and durable. The resin, or amorphous polymer is soluble to a solvent and, therefore, has to be crosslinked after application, thereby providing the resulting film with resistivity to solvents. For this purpose, hydroxyl group-containing vinyl ether which is highly reactive is copolymerized with fluoroolefin so as to produce a resin structure which promotes easy crosslinking by isocyanate.

[0016] The above structure allows the elastic layer 5 to function with stability and uniformity as an electric resistance body and has a small electrostatic capacity. Therefore, even when AC is superposed on DC, the uniform charging ability is not improved to a noticeable degree. As a result, it is not necessary to superpose AC on DC, i.e., high-tension DC voltage should only be applied.

[0017] In a first example of the present invention, to produce the elastic layer 5, there were mixed 100 parts by weight of epichlorohydrin rubber which is a ternary copolymer of epichlorohydrin-ethylene oxide-arylglycidyl ether (Epichlomer CG available from Daiso Co. Ltd. (Japan)), 30 parts by weight of more volatile calcium carbonate (Tamapearl TR-222H, Okatema Industries, Ltd. (Japan)), 10 parts by weight of Sub (Neofactice GT, available from Tenma Sub Chemicals Ltd. (Japan)), 5 parts by weight of zinc flower (Sazex I, Sakai Chemicals, Ltd. (Japan)), 0.5 part by weight of stearic acid (Stearic Acid SA-200, Asahi Denka Co., Ltd. (Japan)), 1 part by weight of vulcanization accelerator (Nocceler TT available from Ouchi Shinko Chemicals Inc. (Japan), 1.5 parts by weight of Nocceler DM also available from Ouchi Shinko Chemicals Inc. (Japan), and 0.25 part by weight of Sulphax H available from Tsurumi Chemicals Inc. (Japan). The mixture was kneaded to prepare a compound having a uniform composition. Then, the mixture was applied to the periphery of a shaft made of stainless steel and having a diameter of 6 mm. Subsequently, the shaft was vulcanized at 170°C for 10 minutes and again vulcanized at 200°C for 2 hours. The surface of the resulting roller was machined to have a roller diameter of 12 mm. The roller was measured to have a medium electric resistance and, physically, a volume resistivity of $2 \times 10^8 \Omega\text{-cm}$, rubber hardness of 33° (JIS A), and surface roughness of $3 \mu\text{m-Rz}$.

EP 0 606 907 B1

[0018] To form the surface layer 6, there were mixed 100 parts by weight of epichlorohydrin rubber of ternary copolymer (Epichlomer CG available from Daiso Co. Ltd. (Japan)), 0.5 part by weight of stearic acid, 5 parts by weight of zinc flower (Sazex I, Sakai Chemicals, Ltd. (Japan)), 1 part by weight of vulcanization accelerator (Nocceler TT available from Ouchi Shinko Chemicals Inc. (Japan)), 1.5 parts by weight of Nocceler DM also available from Ouchi Shinko Chemicals Inc. (Japan), and 0.25 part by weight of Sulphax H available from Tsurumi Chemicals Inc. (Japan). The mixture was kneaded to prepare a compound having a uniform composition. 2.5 parts by weight of the compound was dissolved in a mixture solution of 48.8 parts by weight of toluene and 48.8 parts by weight of 4-methyl-2-pentanone, thereby producing an epichlorohydrin rubber solution containing 2.5 % of solids (paint A-1). Also, to produce the non-adhering resin, 22 parts by weight of solvent-soluble fluorine resin (Lumiflon LF-601C major agent available from Asahi Glass Co. Ltd. (Japan)) and 4.4 parts by weight of isocyanate-based hardener (Lumiflon LF-601C hardener also available from Asahi Glass Co., Ltd. (Japan)) were dissolved in a mixture of 36.8 parts by weight of toluene and 36.8 parts by weight of xylene. The resulting fluorine-based resin solution contained 10 % of solids (paint B). 40 parts by weight of paint B and 100 parts by weight of paint A-1 were mixed (ratio in solid: paint A-1/paint B = 1.0/1.6). After the mixture of paints B and A-1 were coated on the elastic layer 5 by dipping, it was dried at 160°C for 30 minutes to form a 20 μm thick layer. This surface layer 6 had a volume resistivity of $8 \times 10^9 \Omega \cdot \text{cm}$.

[0019] The charging roller 2 fabricated by the above procedure was substituted for a primary corona charger included in a positive-to-positive development type copier (FT3300 available from Ricoh Co.Ltd. (Japan)). In this condition, the roller 2 was held in contact with and rotated by the drum 3 while a DC voltage of 1.4 kV was applied to the core 4 thereof as a primary charge voltage. Table 1, which is shown below, indicates a light potential measured with the charging roller 2 together with the result of evaluation of an image in a row labeled Ex. (Example) 1. Even after the copier was operated to produce 5,000 copies, the potential and image were free from defects. For the measurement of the volume resistivity of the elastic layer 5, each sample was left in a 20°C, 60 % RH atmosphere for 16 hours, use was made of an electrometer 610C, and an electrode for measurement was implemented by a tape of copper foil (No. 1245 available from 3M). Further, to measure the volume resistivity of the surface layer alone, the material constituting it was painted on a thin aluminum plate (0.2 mm thick) to a thickness of about 50 μm. Then, the aluminum plate was left in a 20°C, 60RH atmosphere for 16 hours; for the measurement, use was made of a resistance measuring cell (16008A available from YHP) and above-mentioned electrometer 610C.

TABLE 1

Ex. No.	Elastic Layer (Volume Resistivity $\Omega \cdot \text{cm}$)	Surface Layer (Volume Resistivity $\Omega \cdot \text{cm}$)	Surface Layer Thickness (μm)	Potential (V)	Image Defect	Toner Filming
Ex. 1	Epichlomer CG (2×10^8)	fluorine/ Epichlomer CG (8×10^9)	20	-730	not occurred	not occurred
				-725	not occurred	not occurred
Ex. 2	Same as above	same as above	90	-720	not occurred	not occurred
				-720	not occurred	not occurred
Ex. 3	Epichlomer C (7×10^7)	fluorine/ Epichlomer C (3×10^9)	20	-740	not occurred	not occurred
				-740	not occurred	not occurred
Ex. 4	Epichlomer CG/ Epichlomer C (1×10^8)	fluorine resin /Epichlomer CG (1×10^{10})	6	-800	not occurred	not occurred
				-795	not occurred	not occurred
Ex. 5	Epichlomer CG (2×10^8)	fluorine resin (2×10^{14})	8	-720	not occurred	not occurred
				-720	not occurred	not occurred
Ex. 6	Epichlomer C (7×10^7)	same as above	5	-740	not occurred	not occurred
				-735	not occurred	not occurred

TABLE 1 (continued)

Ex. No.	Elastic Layer (Volume Resistivity $\Omega\cdot\text{cm}$)	Surface Layer (Volume Resistivity $\Omega\cdot\text{cm}$)	Surface Layer Thickness (μm)	Potential (V)	Image Defect	Toner Filming
Com. Ex. 1	Epichlomer CG (7×10^8)	—	—	-800	not occurred	not occurred
				-740	occurred (irregular density)	occurred
Com. Ex. 2	Epichlomer CG (2×10^8)	fluorine resin /Epichlomer CG (8×10^9)	230	-670	occurred (irregular density)	not occurred
				—	—	—
Com. Ex. 3	Epichlomer CG/ Epichlomer C (1×10^8)	fluorine resin (2×10^{14})	30	-590	occurred (low density)	not occurred
				—	—	—
Com. Ex. 4	Epichlomer CG (2×10^8)	fluorine resin (2×10^{14})	11	660	occurred (slightly low density)	not occurred
				—	—	—
Com. Ex. 5	Same as above	same as above	15	620	occurred (low density)	not occurred
				—	—	—

[0020] In each Example shown in Table 1, the upper and lower parts of the columns "Potential (V)", "Image Defect", and "Toner Filming" are respectively representative of the initial condition and the condition after 5,000 copies have been produced.

[0021] In Table 1, Example 2 is identical with Example 1 described above except that the surface layer 6 was 90 μm thick.

[0022] In Example 3, to produce the elastic layer 5, there were mixed 100 parts by weight of epichlorohydrin rubber of binary copolymer of epichlorohydrin-ethylene oxide (Epichromer C available from Daiso Co. Ltd. (Japan)), 30 parts by weight of more volatile calcium carbonate, 10 parts by weight of Sub (Neo factice GT available from Tenma Sub Chemicals Ltd. (Japan)), 5 parts by weight of zinc flower (Sazex I, Sakai Chemicals, Ltd. (Japan)), 0.5 part by weight of stearic acid (Stearic Acid SA-200, Asahi Denka Co., Ltd. (Japan)), 1 part by weight of vulcanization accelerator (Nocceler TT available from Ouchi Shinko Chemicals Inc. (Japan)), 1.5 parts by weight of Nocceler DM also available from Ouchi Shinko Chemicals, and 0.25 part by weight of Sulfax H available from Tsurumi Chemicals were mixed and kneaded to prepare a compound having a uniform composition. The compound was applied to the periphery of a shaft made of stainless steel and having a diameter of 6 mm, vulcanized at 170°C for 10 minutes, and then vulcanized at 200°C for 2 hours. The surface of the resulting roller was machined to provide the roller with a diameter of 12 mm. The roller was measured to have a medium electric resistance and, physically, a volume resistivity of $7 \times 10^7 \Omega\cdot\text{cm}$, rubber hardness of 32° (JIS A), and surface roughness of 3 μm ·Rz.

[0023] In Example 3, to form the surface layer 6, there were mixed and kneaded 100 parts by weight of epichlorohydrin rubber of binary copolymer (Epichlomer C available from Daiso), 0.5 part by weight of stearic acid, 5 parts by weight of zinc flower, 1 part of vulcanization accelerator (Nocceler TT available from Ouchi Shinko Chemicals Inc. (Japan)), 1.5 parts by weight of Nocceler DM also available from Ouchi Shinko Chemicals, and 0.25 part by weight of Sulfax H available from Tsurumi Chemicals, thereby preparing a compound having a uniform composition. 2.5 parts by weight of the compound was dissolved in a mixture of 48.8 parts by weight of toluene and 48.8 parts by weight of 4-methyl-2-pentanone. The resulting solution of epichlorohydrin rubber contained 2.5% of epichlorohydrin (paint A-2). 100 parts by weight of the paint A-2 and 40 parts by weight of paint B were mixed (ratio in solid: paint A-2/paint B = 1.0/1.6). The mixture was coated on the elastic layer 5 by dipping and then dried at 160°C for 30 minutes to form a 20 μm thick layer. The charging roller 2 with such a structure had properties shown in Example 3 of Table 1.

[0024] In Example 4, to form the elastic layer 5, the compound of Example 1 (ternary copolymer of epichlorohydrin-ethylene oxide-arylglycidyl ether) and the compound of Example 3 (binary copolymer of epichlorohydrin-ethylene oxide) were mixed at a ratio of 1:1. Then, the procedure of Example 1 was repeated to fabricate a charge roller having a medium electric resistance, diameter of 12 mm, volume resistivity of $1 \times 10^8 \Omega\text{-cm}$, rubber hardness of 33° (JIS A), and surface roughness of $3 \mu\text{m}\cdot\text{Rz}$. To form the surface layer 6, 100 parts by weight of paint A-1 and 50 parts by weight of paint B were mixed (ratio in solid: paint A-1/paint B = 1/2). The mixture paint was coated on the elastic layer 5 by dipping, and then dried at 160°C for 30 minutes to form a $6 \mu\text{m}$ thick layer. The surface layer 6 had a volume resistivity of $1 \times 10^{10} \Omega\text{-cm}$. The properties of the roller 2 are shown in Example 4 of Table 1.

[0025] In Example 5, only the paint B was coated on the elastic layer 5 of Example 1 by dipping and then dried at 100°C for 30 minutes to form an $8 \mu\text{m}$ thick surface layer 6. The layer 6 had a volume resistivity of $2 \times 10^{14} \Omega\text{-cm}$. The properties of the resulting roller 2 are indicated in Example 5 of Table 1.

[0026] In Example 6, only the paint B was coated on the elastic layer 5 of Example 3 by dipping and then dried at 100°C for 30 minutes to form a $5 \mu\text{m}$ thick surface layer. The properties of the resulting roller 2 are shown in Example 6 of Table 1.

[0027] In Table 1, Comparative Example (Comp. Ex.) 1 is representative of a case wherein a roller 2 had the elastic layer 5 of Example 1 and did not have the surface layer 6. It will be seen that when 5,000 copies are produced, irregular image density and toner filming occur.

[0028] Comparative Example 2 is identical with Example 1 except that the surface layer 6 was 230 μm thick. The roller 2 had a hardness of 48° (JIS A).

[0029] In Comparative Example 3, only the paint B was coated on the elastic layer 5 of Example 4 by dipping and then dried at 100°C for 30 minutes to form a 30 μm thick surface layer 6. It will be seen that irregular image density and toner filming occur.

[0030] Comparative Example 4 is identical with Example 6 except that the surface layer 6 was 11 μm thick. In this example, charge potential and, therefore, image density is slightly lowered, as Table 1 indicates.

[0031] Comparative Example 5 is identical with Example 6 except that the surface layer 6 was 15 μm thick. In this case, charge potential and, therefore, image density is further lowered, as Table 1 also indicates.

[0032] In summary, it will be seen that the present invention provides a charging roller having various unprecedented advantages, as enumerated below.

(1) The roller is capable of charging a photoconductive element uniformly only if applied with a high-tension DC voltage. This eliminates the need for an AC voltage and produces no ozone. In addition, since the surface of the roller is not adhering, toner particles are prevented from depositing thereon over a long period of time.

(2) The toner particles are prevented from filming on the surface layer of the roller, while the photoconductive element is uniformly charged.

(3) Even when pin holes existing in the photoconductive element are brought into contact with the roller, breakdown due to current supply is eliminated.

(4) A non-adhering layer for eliminating the deposition of toner particles can be easily formed on the elastic layer.

[0033] Various modifications will become possible for those skilled in the art after receiving the teachings of the present disclosure without departing from the scope thereof.

Claims

1. A charging roller (2) for charging a photoconductive element (3) included in an image forming apparatus, comprising:

an elastic layer (5) made of a substance having a medium electric volume resistivity in a range of about 7×10^7 to $2 \times 10^8 \Omega\text{-cm}$; and

a surface layer (6) formed on the elastic layer (5),

characterized by the following features:

a) said surface layer (6) being made of a substance which is non-adhering with respect to toner and having a greater non-adhering property than said substance having a medium electric volume resistivity; and

b) said substance having a medium volume resistivity being mainly constituted by epichlorohydrin rubber implemented by a ternary copolymer of epichlorohydrin-ethylene oxide-arylglycidyl ether or a binary copolymer of epichlorohydrin-ethylene oxide or a combination thereof.

2. A charging roller as claimed in claim 1, wherein said surface layer is 5 μm to 10 μm thick.
3. A charging roller as claimed in one of claims 1 or 2, wherein said non-adhering substance comprises a fluorine-containing crosslinked copolymer produced by crosslinking by isocyanate a fluorine-containing copolymer which is made up of fluoroolefine and hydroxyl group-containing vinyl ether.

Patentansprüche

1. Ladewalze (2) zum Laden eines fotoleitfähigen Elements (3), das in einem Bilderzeugungsgerät enthalten ist, die aufweist:
- eine elastische Schicht (5), die aus einem Material hergestellt ist, daß einen mittleren elektrischen Volumenwiderstand in einem Bereich von 7×10^7 bis $2 \times 10^8 \Omega\text{-cm}$ hat; und
- eine Oberflächenschicht (6), die auf der elastischen Schicht (5) ausgebildet ist, gekennzeichnet durch die folgenden Merkmale:
- a) die Oberflächenschicht (6) ist aus einem Material bzw. einer Substanz hergestellt, die im Hinblick auf Toner nicht haftet und eine größere bzw. bessere Nichthaftungseigenschaft als die Substanz bzw. das Material hat, das einen mittleren elektrischen Volumenwiderstand hat; und
- b) die Substanz, die einen mittleren Volumenwiderstand hat, ist hauptsächlich durch Epichlorhydringummi gebildet, der durch ein ternäres Copolymer von Epichlorhydrin-Ethylenoxid-Arylglycidylether oder ein binäres Copolymer von Epichlorhydrin-Ethylenoxid oder einer Kombination davon verwirklicht ist.
2. Ladewalze nach Anspruch 1, wobei die Oberflächenschicht 5 μm bis 10 μm dick ist.
3. Ladewalze nach einem der Ansprüche 1 oder 2, wobei die nichthaftende Substanz bzw. Material ein Fluor enthaltendes vernetztes Copolymer aufweist, das durch Vernetzen durch ein Isocyanat eines Fluor enthaltenden Copolymers, das durch Fluoroolefin und eine Hydroxylgruppe enthaltendes Vinylether hergestellt ist.

Revendications

1. Rouleau (2) de charge d'un élément photoconducteur (3) incorporé dans un appareil de formation d'images, comprenant :
- une couche élastique (5) formée d'une substance ayant une résistivité électrique en volume moyenne comprise dans une plage allant d'environ $7 \cdot 10^7$ à $2 \cdot 10^8 \text{ W.cm}$, et
- une couche de surface (6) formée sur la couche élastique (5),
- caractérisé par les propriétés suivantes :
- a) la couche de surface (6) est formée d'une substance qui n'adhère pas à un développeur et qui a une propriété de défaut d'adhérence supérieure à celle de la substance ayant une résistivité électrique en volume moyenne, et
- b) la substance ayant une résistivité en volume moyenne est essentiellement constituée d'un caoutchouc d'épichlorhydrine sous forme d'un copolymère ternaire d'épichlorhydrine, d'oxyde d'éthylène et d'éther arylglycidyle ou d'un copolymère binaire d'épichlorhydrine et d'oxyde d'éthylène ou d'une combinaison de tels polymères.
2. Rouleau de charge selon la revendication 1, dans lequel la couche de surface a une épaisseur de 5 à 10 μm .
3. Rouleau de charge selon l'une des revendications 1 et 2, dans lequel la substance non adhérente est un copolymère réticulé contenant du fluor, produit par réticulation par un isocyanate d'un copolymère contenant du fluor qui est constitué d'une oléfine fluorée et d'un éther vinylique contenant un groupe hydroxyle.

Fig. 1

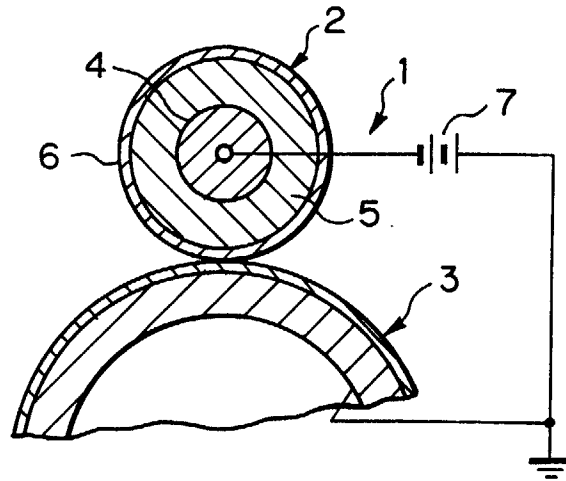

Fig. 2

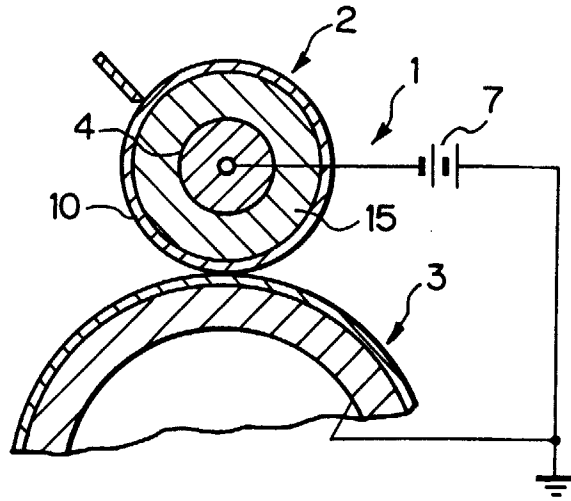

Fig. 3

