

May 20, 1958

F. GALEAZZI

2,835,534

PUSH-BUTTON SPRAYING DEVICE WITH SAFETY CAP

Filed July 20, 1954

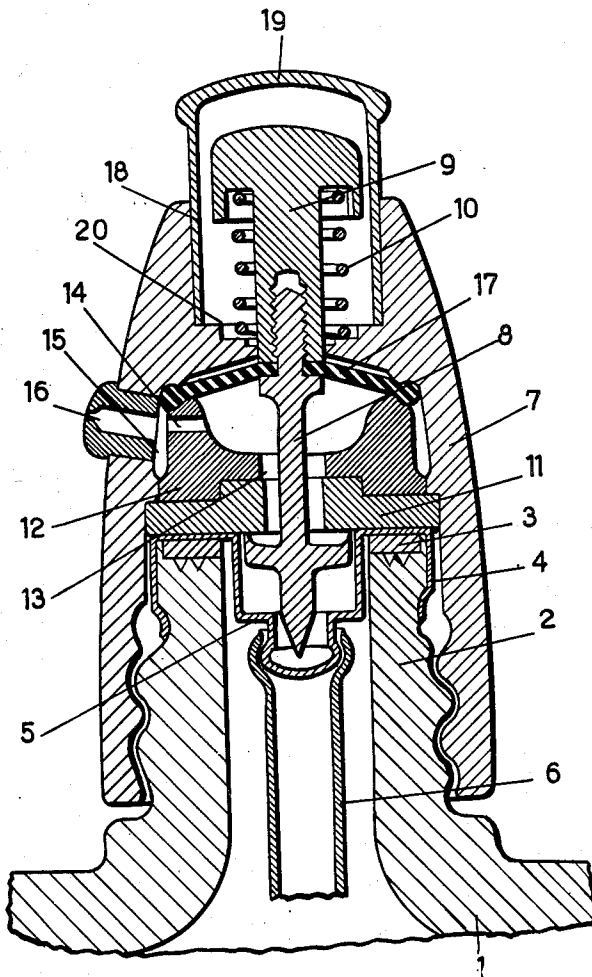

INVENTOR.

Frances Galeazzi

BY

Sturms, Dins, Miller & Maher
his attorneys

1

2,835,534

PUSH-BUTTON SPRAYING DEVICE WITH SAFETY CAP

Franco Galeazzi, Milan, Italy

Application July 20, 1954, Serial No. 444,567

Claims priority, application Italy July 24, 1953

1 Claim. (Cl. 299—95)

The present invention relates to a spraying device with a safety cap, particularly for the spraying of scents, cosmetics, disinfectants and the like.

There are known devices for the spraying of substances by means of a gaseous pressure provided inside the vessel, particularly for scents, cosmetics, disinfectants and the like, constituted essentially by a vessel provided with one or more spraying nozzles and with a means adapted to ensure an airtight closure after introducing the substance to be sprayed (in liquid or powdery condition) together with a liquid having a boiling temperature somewhat below ordinary temperature, in such a manner that at ordinary temperature the content be urged to come out by effect of the gaseous pressure created inside the vessel. The spraying of the substance under pressure takes place through the seat of a valve the stem whereof is controlled by means of a springed push-button projecting externally from the member adapted to ensure tightness, in such a manner as to put the immersion tube in communication with the spraying nozzle.

The devices made in this way offer the inconvenience of requiring a careful wrapping or packaging in order to avoid unintentional spraying of the content, the push-button for controlling the intercepting valve being subject to receiving accidental impacts.

Another inconvenience of the aforesaid devices is that the push-button is subject to being depressed involuntarily when the device is being gripped to be used or to be displaced.

It is an object of the present invention to eliminate the above mentioned inconveniences by providing the aforementioned devices with a safety cap to protect the control push-button for the intercepting valve.

In particular, the invention relates to a spraying device comprising a cover provided with one or more nozzles and that can be screwed onto the neck of the vessel destined to contain the substances under pressure to be sprayed and an intercepting valve accommodated inside said cover, the stem of which is actuated by means of a springed push-button, characterized in that the push-button projects from the cover through a cavity having transversal dimensions larger than those of the push-button in such a manner as to provide an interspace into which is fitted, to touch the bottom of said cavity, a safety cap having internal transversal dimensions larger than the external transversal dimensions of the push-button and external transversal dimensions essentially equal to the internal dimensions of the cavity in such a manner as to be forced against the internal lateral surface of the said cavity.

In the accompanying drawing, the single figure represents a vertical axial section of a spraying device with a safety cap according to the present invention applied thereto.

With reference to the drawing, with 1 is indicated the vessel destined to contain the substances to be sprayed, provided with a neck 2 threaded externally.

2

On the neck 2 there is fitted the member 4 in such a way that it rests thereon with the intermediary of an interposed gasket 3. The member 4 surrounds externally said neck 2 over a certain length and inside said neck 2 it is shaped as a small cup 5 to which is connected the immersion tube 6.

On said neck there is screwed the cover 7 containing the mushroom-shaped valve 8 which has its stem screwed to the push-button 9 urged to return upwards by the helical spring 10 and which with the member 4 abuts and provides tightness against the gasket 11 which is pressed against the member 4 by a shaped body 12 having a central hole 13 for the passage of the stem of the valve and a conduit 14 opening into the annular chamber 15 that comes to be formed between the body 12 and the cover 7 and which is in communication with the nozzle 16.

The small cup 5 acts as a provisional sealing disc, which is perforated by the point with which the valve 8 is provided. Tightness in respect to the push-button 9 is ensured by the membrane 17.

The push-button 9 projects from the cover 7 through the cavity 18 having circular section with a diameter larger than that of the push-button 9 in such a manner as to provide an interspace into which is fitted so as to bear against the bottom 20 of said cavity, a safety cap 19 having an internal diameter larger than that of the push-button and an external diameter substantially equal to that of the cavity in such a way as to be forced against the internal lateral surface of said cavity. The cap is of transparent synthetic material to allow inspection of the inside of the push-button.

The spraying device is known per se and has been described in its particulars merely for the purpose to more clearly illustrate the application and employment of the safety cap, but it is understood that the scope of the present invention comprises only the application of the cap as hereinbefore specified.

From the above it will be apparent that with the devices provided with safety caps, the push-button is no longer subject to accidental impacts causing unintentional spraying of the substances contained in the vessel.

What I claim is:

In a spraying device for dispensing material as a spray from a container adapted to hold such material in liquid form under pressure and including a cover member adapted to be fixed on the neck of the container and having an outlet means in communication with the interior of the neck of the container, a valve means controlling such communication and a push button actuator for the valve means; the improvement which comprises said cover member having an upper end formed with an axial cavity in which the push button actuator is slidably disposed, said cavity being of a cross-sectional area only slightly greater than the cross-sectional area of the push button actuator and a hollow transparent cup-shaped safety cap member having an open end and a closed end, said safety cap member being of an external cross-sectional area and configuration similar to the cross-sectional configuration and area of the cavity to fit snugly in the cavity and be frictionally retained therein and being of an internal cross-sectional area just slightly greater than the cross-sectional area of the push button actuator and said cavity having an inwardly extending shoulder at its lower end against which the edge of the open end of the safety cap member abuts to space the closed end thereof slightly above the push button actuator and locate the safety cap member around the push button actuator in slightly spaced relationship therewith so that the cap member assists in keeping the actuator in correct position to prevent canting of the valve means, and said closed end of the safety cap member having a peripheral outwardly protruding enlarge-

ment for gripping the cap member to pull it axially from the cavity.

References Cited in the file of this patent

UNITED STATES PATENTS

1,800,156 Rotheim ----- Apr. 7, 1931

1,985,455
2,612,293
2,621,973
2,653,053
2,707,968
2,731,298

5

Mosby ----- Dec. 25, 1934
Michel ----- Sept. 30, 1952
Lodes ----- Dec. 16, 1952
Henchert ----- Sept. 22, 1953
Efford ----- May 10, 1955
Green ----- Jan. 17, 1956