



(12) **DEMANDE DE BREVET CANADIEN
CANADIAN PATENT APPLICATION**

(13) **A1**

(86) Date de dépôt PCT/PCT Filing Date: 2019/09/20
(87) Date publication PCT/PCT Publication Date: 2020/03/26
(85) Entrée phase nationale/National Entry: 2021/03/19
(86) N° demande PCT/PCT Application No.: US 2019/052160
(87) N° publication PCT/PCT Publication No.: 2020/061457
(30) Priorité/Priority: 2018/09/20 (US62/733,974)

(51) Cl.Int./Int.Cl. *A61K 9/127* (2006.01),
A61K 9/19 (2006.01)
(71) Demandeur/Applicant:
MODERNATX, INC., US
(72) Inventeurs/Inventors:
HORHOTA, ALLEN, US;
MCLAUGHLIN, CHRISTOPHER KARL, US;
CHENEY, JESSICA, US;
GELDHOF, BEN, US;
HRKACH, JEFFREY, US;
MOORE, MELISSA J., US;
HOGE, STEPHEN G., US
(74) Agent: SMART & BIGGAR LLP

(54) Titre : PREPARATION DE NANOPARTICULES LIPIDIQUES ET LEURS METHODES D'ADMINISTRATION
(54) Title: PREPARATION OF LIPID NANOPARTICLES AND METHODS OF ADMINISTRATION THEREOF

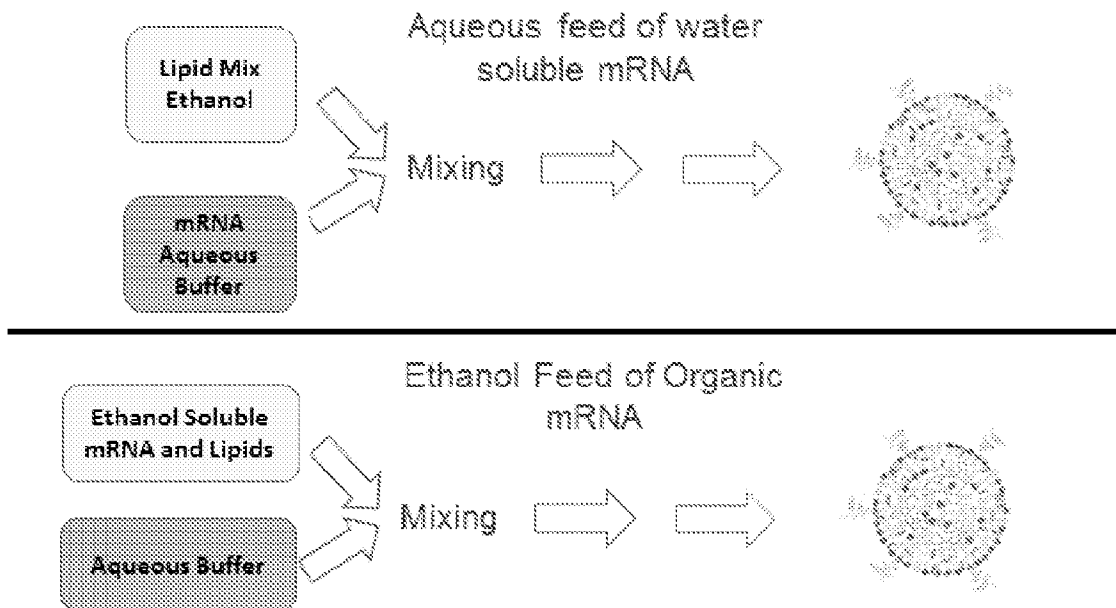

Figure 1

(57) **Abrégé/Abstract:**

The present disclosure provides methods of producing lipid nanoparticle (LNP) formulations and the produced LNP formulations thereof. The present disclosure also provides therapeutic and diagnostic uses related to the produced LNP formulations.

(12) INTERNATIONAL APPLICATION PUBLISHED UNDER THE PATENT COOPERATION TREATY (PCT)

(19) World Intellectual Property Organization
International Bureau

(43) International Publication Date
26 March 2020 (26.03.2020)



(10) International Publication Number
WO 2020/061457 A1

- (51) **International Patent Classification:**
A61K 9/127 (2006.01) A61K 9/19 (2006.01)
- (21) **International Application Number:**
PCT/US2019/052160
- (22) **International Filing Date:**
20 September 2019 (20.09.2019)
- (25) **Filing Language:** English
- (26) **Publication Language:** English
- (30) **Priority Data:**
62/733,974 20 September 2018 (20.09.2018) US
- (71) **Applicant: MODERNATX, INC.** [US/US]; 200 Technology Square, Cambridge, Massachusetts 02139 (US).
- (72) **Inventors: HORHOTA, Allen;** c/o ModernaTX, Inc., 200 Technology Square, Cambridge, Massachusetts 02139 (US). **MCLAUGHLIN, Christopher Karl;** c/o ModernaTX, Inc., 200 Technology Square, Cambridge, Massachusetts 02139 (US). **CHENEY, Jessica;** c/o ModernaTX, Inc., 200 Technology Square, Cambridge, Massachusetts 02139 (US). **GELDHOF, Ben;** c/o ModernaTX, Inc., 200 Technology Square, Cambridge, Massachusetts 02139 (US). **HRKACH, Jeffrey;** c/o ModernaTX, Inc., 200 Technology Square, Cambridge, Massachusetts 02139 (US). **MOORE, Melissa J.;** c/o ModernaTX, Inc., 200 Technology Square, Cambridge, Massachusetts 02139 (US). **HOGUE, Stephen** G.; c/o ModernaTX, Inc., 200 Technology Square, Cambridge, Massachusetts 02139 (US).
- (74) **Agent: ERLACHER, Heidi A.** et al.; Cooley LLP, 1299 Pennsylvania Avenue, N.W., Suite 700, Washington, District of Columbia 20004 (US).
- (81) **Designated States** (unless otherwise indicated, for every kind of national protection available): AE, AG, AL, AM, AO, AT, AU, AZ, BA, BB, BG, BH, BN, BR, BW, BY, BZ, CA, CH, CL, CN, CO, CR, CU, CZ, DE, DJ, DK, DM, DO, DZ, EC, EE, EG, ES, FI, GB, GD, GE, GH, GM, GT, HN, HR, HU, ID, IL, IN, IR, IS, JO, JP, KE, KG, KH, KN, KP, KR, KW, KZ, LA, LC, LK, LR, LS, LU, LY, MA, MD, ME, MG, MK, MN, MW, MX, MY, MZ, NA, NG, NI, NO, NZ, OM, PA, PE, PG, PH, PL, PT, QA, RO, RS, RU, RW, SA, SC, SD, SE, SG, SK, SL, SM, ST, SV, SY, TH, TJ, TM, TN, TR, TT, TZ, UA, UG, US, UZ, VC, VN, ZA, ZM, ZW.
- (84) **Designated States** (unless otherwise indicated, for every kind of regional protection available): ARIPO (BW, GH, GM, KE, LR, LS, MW, MZ, NA, RW, SD, SL, ST, SZ, TZ, UG, ZM, ZW), Eurasian (AM, AZ, BY, KG, KZ, RU, TJ, TM), European (AL, AT, BE, BG, CH, CY, CZ, DE, DK, EE, ES, FI, FR, GB, GR, HR, HU, IE, IS, IT, LT, LU, LV, MC, MK, MT, NL, NO, PL, PT, RO, RS, SE, SI, SK, SM, TR), OAPI (BF, BJ, CF, CG, CI, CM, GA, GN, GQ, GW, KM, ML, MR, NE, SN, TD, TG).

(54) **Title:** PREPARATION OF LIPID NANOPARTICLES AND METHODS OF ADMINISTRATION THEREOF

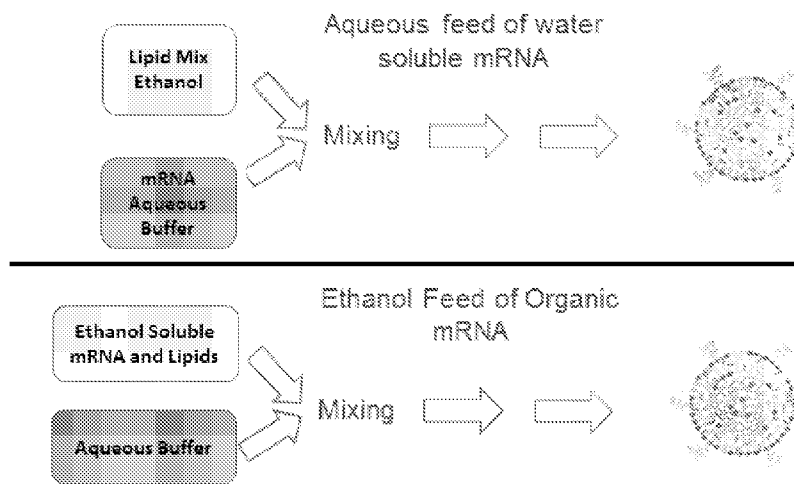

Figure 1

(57) **Abstract:** The present disclosure provides methods of producing lipid nanoparticle (LNP) formulations and the produced LNP formulations thereof. The present disclosure also provides therapeutic and diagnostic uses related to the produced LNP formulations.



WO 2020/061457 A1

WO 2020/061457 A1 

Declarations under Rule 4.17:

- *as to applicant's entitlement to apply for and be granted a patent (Rule 4.17(ii))*

Published:

- *with international search report (Art. 21(3))*
- *before the expiration of the time limit for amending the claims and to be republished in the event of receipt of amendments (Rule 48.2(h))*
- *with sequence listing part of description (Rule 5.2(a))*

PREPARATION OF LIPID NANOPARTICLES AND METHODS OF ADMINISTRATION THEREOF

Related Applications

[0001] This application claims priority to, and the benefit of, U.S. Provisional Application No. 62/733,974, filed September 20, 2018, the entire contents of which is incorporated herein by reference.

Incorporation-by-Reference of Sequence Listing

[01] The contents of the file named "MRNA-048_001WO_ST25.txt", which was created on September 20, 2019, and is 1 KB in size are hereby incorporated by reference in their entirety.

Field of Disclosure

[0002] The present disclosure provides novel methods of producing nucleic acid lipid nanoparticle (LNP) formulations, the produced formulations thereof, and the related therapeutic and/or diagnostic uses.

Background

[0003] The effective targeted delivery of biologically active substances such as small molecule drugs, proteins, and nucleic acids represents a continuing medical challenge. In particular, the delivery of nucleic acids to cells is made difficult by the relative instability and low cell permeability of such species. Thus, there exists a need to develop methods and compositions to facilitate the delivery of therapeutics and prophylactics such as nucleic acids to cells.

[0004] Lipid-containing nanoparticles or lipid nanoparticles, liposomes, and lipoplexes have proven effective as transport vehicles into cells and/or intracellular compartments for biologically active substances such as small molecule drugs, proteins, and nucleic acids. Though a variety of such lipid-containing nanoparticles have been demonstrated, improvements in safety, efficacy, and specificity are still lacking.

Summary

[0005] In some aspects, the present disclosure provides a method of producing a lipid nanoparticle (LNP) composition, the method comprising: (i) mixing an aqueous buffer solution and an organic solution, thereby forming a lipid nanoparticle (LNP) formulation comprising a lipid nanoparticle (LNP) encapsulating a nucleic acid; and (ii) processing the lipid nanoparticle (LNP) formulation, thereby forming the lipid nanoparticle composition; wherein the organic solution comprises an organic solvent-soluble nucleic acid and an ionizable lipid in an organic solvent; and wherein the organic solvent-soluble nucleic acid comprises a hydrophobic organic cation.

[0006] In some aspects, the present disclosure provides a method of administering a lipid nanoparticle (LNP) formulation to a patient, the method comprising: (i) providing an aqueous solution having a first pH in a range of from about 7.0 to about 9.0 comprising a therapeutic and/or prophylactic agent in an aqueous buffer and an organic solution comprising an ionizable lipid and an encapsulation agent in an organic solvent; (ii) forming a lipid nanoparticle formulation comprising a lipid nanoparticle encapsulating the therapeutic and/or prophylactic agent by mixing the aqueous solution and the organic solution such that the lipid nanoparticle formulation has a second pH in a range of from about 7.0 to about 9.0 and comprises at least 1% by volume of the organic solvent relative to the total volume of the lipid nanoparticle formulation; and (iii) administering the lipid nanoparticle formulation to the patient less than about 72 hours after the mixing.

[0007] In some aspects, the present disclosure provides a method of administering a lipid nanoparticle (LNP) formulation to a patient, the method comprising: (i) providing an aqueous solution having a first pH in a range of from about 4.5 to about less than 7.0 comprising a therapeutic and/or prophylactic agent in an aqueous buffer and an organic solution comprising an ionizable lipid in an organic solvent; (ii) forming a lipid nanoparticle formulation comprising a lipid nanoparticle encapsulating the therapeutic and/or prophylactic agent by mixing the aqueous solution and the organic solution such that the lipid nanoparticle formulation has a second pH in a range of from about 4.5 to about less than 7.0 and comprises at least 1% by volume of the organic solvent relative to the total volume of the lipid nanoparticle formulation; and (iii) administering the lipid nanoparticle formulation to the patient less than about 72 hours after the mixing.

[0008] In some aspects, the present disclosure provides a method of administering a lipid nanoparticle (LNP) formulation to a patient, the method comprising: (i) providing an aqueous buffer solution having a first pH in a range of from about 7.0 to about 9.0 and an organic solution comprising an ionizable lipid, an encapsulation agent, and a therapeutic and/or prophylactic agent in an organic solvent; (ii) forming a lipid nanoparticle formulation comprising a lipid nanoparticle encapsulating the therapeutic and/or prophylactic agent by mixing the aqueous buffer solution and the organic solution such that the lipid nanoparticle formulation has a second pH in a range of from about 7.0 to about 9.0 and comprises at least about 1% by volume of the organic solvent relative to the total volume of the lipid nanoparticle formulation; and (iii) administering the lipid nanoparticle formulation to the patient less than about 72 hours after the mixing.

[0009] In some aspects, the present disclosure provides a method of administering a lipid nanoparticle (LNP) formulation to a patient, the method comprising: (i) providing an aqueous buffer solution having a first pH in a range of from about 4.5 to about less than 7.0 and an organic solution comprising an ionizable lipid and a therapeutic and/or prophylactic agent in an organic solvent; (ii) forming a lipid nanoparticle formulation comprising a lipid nanoparticle encapsulating the therapeutic and/or prophylactic agent by mixing the aqueous buffer solution and the organic solution such that the lipid nanoparticle formulation has a second pH in a range of from about 4.5 to about less than 7.0 and comprises at least 1% by volume of the organic solvent relative to the total volume of the lipid nanoparticle formulation; and (iii) administering the lipid nanoparticle formulation to the patient less than about 72 hours after the mixing.

[0010] In some aspects, the present disclosure provides a method of treating or preventing a disease or disorder, comprising administering a lipid nanoparticle (LNP) formulation to a subject in need thereof according to the method disclosed herein.

[0011] In some aspects, the present disclosure provides a lipid nanoparticle (LNP) formulation and/or lipid nanoparticle (LNP) composition being prepared by the method disclosed herein.

[0012] In some aspects, the present disclosure provides a lipid nanoparticle (LNP) formulation and/or lipid nanoparticle (LNP) composition, prepared by a method disclosed herein, for treating or preventing a disease or disorder.

[0013] In some aspects, the present disclosure provides an aqueous buffer solution disclosed herein and an organic solution disclosed herein.

[0014] In some aspects, the present disclosure provides use of an aqueous buffer solution and/or an organic solution disclosed herein in the manufacture of a medicament (e.g., a lipid nanoparticle (LNP) formulation and/or lipid nanoparticle (LNP) composition) for treating or preventing a disease or disorder.

[0015] In some aspects, the present disclosure provides a kit comprising an aqueous buffer solution disclosed herein and an organic solution disclosed herein.

[0016] Unless otherwise defined, all technical and scientific terms used herein have the same meaning as commonly understood by one of ordinary skill in the art to which this disclosure belongs. Although methods and materials similar or equivalent to those described herein can be used in the practice or testing of the present disclosure, suitable methods and materials are described below. All publications, patent applications, patents, and other references mentioned herein are incorporated by reference in their entirety. In the case of conflict, the present specification, including definitions, will control. In addition, the materials, methods, and examples are illustrative only and are not intended to be limiting.

[0017] Other features and advantages of the disclosure will be apparent from the following detailed description and claims.

Brief Description of the Drawings

[0018] Figure 1 is a schematic diagram illustrating the difference between aqueous feed mRNA (AFM) and organic feed mRNA (OFM) lipid nanoparticle formulation processes.

[0019] Figure 2 is a cryo image of organic feed mRNA formed lipid nanoparticles.

[0020] Figure 3 is a graph comparing in vitro expression of aqueous feed mRNA (AFM) and organic feed mRNA (OFM). The squares represent AFM and the circles represent OFM.

[0021] Figure 4 is a graph comparing in vitro expression of aqueous feed mRNA (AFM) NanoAssemblr mixing, AFM nanoprecipitation mixing, and organic feed mRNA (OFM) nanoprecipitation mixing.

[0022] Figure 5 is a schematic diagram illustrating the experimental T-mixing process set-up.

[0023] Figure 6 is a cryo image of organic feed mRNA formed lipid nanoparticles.

[0024] Figure 7 is a graph comparing in vitro expression of aqueous feed mRNA (AFM) 96-well mixing and organic feed mRNA (OFM) 96-well mixing individually and pooled. The squares represent OFM 96-well Replicate A, the dark triangles represent OFM 96-well Replicate B, the light triangles represent OFM 96-well Replicate C, the circles represent OFM 96-well pooled, and the diamonds represent AFM 96-well.

[0025] Figure 8 is a graph comparing average lipid nanoparticle diameter and encapsulation efficiency of OFM and AFM lipid nanoparticles formed by 96-well mixing and microfluidic mixing.

[0026] Figure 9 is a graph comparing luciferase expression levels in mice (whole body flux) 6 hours after intravenous administration of PBS (1); 0.5 mg/kg lipid nanoparticle formulations prepared by a control aqueous feed mRNA method (2); and 0.5 mg/kg lipid nanoparticle formulations prepared by methods of the disclosure employing organic feed mRNA T-mixing (3) and 96-well plate high-throughput mixing (4).

[0027] Figure 10 is a graph comparing luciferase expression levels in mice (whole body flux) 24 hours after intravenous administration of PBS (1); 0.5 mg/kg lipid nanoparticle formulations prepared by a control aqueous feed mRNA method (2); and 0.5 mg/kg lipid nanoparticle formulations prepared by methods of the disclosure employing organic feed mRNA T-mixing (3) and 96-well plate high-throughput mixing (4).

[0028] Figures 11A-11D are whole body in vivo imaging system (IVIS) bioluminescence images of mice 6 hours after intravenous administration of PBS (Figure 11A); 0.5 mg/kg lipid nanoparticle formulations prepared by a control aqueous feed mRNA method (Figure 11B); and 0.5 mg/kg lipid nanoparticle formulations prepared by methods of the disclosure employing organic feed mRNA T-mixing (Figure 11C) and 96-well plate high-throughput mixing (Figure 11D).

[0029] Figures 12A-12D are ex vivo bioluminescence images of mice lung (1), liver (2, circled), and spleen (3) tissue distribution 6 hours after intravenous administration of PBS (Figure 12A); 0.5 mg/kg lipid nanoparticle formulations prepared by a control aqueous feed mRNA method (Figure 12B); and 0.5 mg/kg lipid nanoparticle formulations prepared by methods of the disclosure employing organic feed mRNA T-mixing (Figure 12C) and 96-well plate high-throughput mixing (Figure 12D).

[0030] Figures 13A-13C are graphs comparing luciferase expression levels in ex vivo mice liver (Figure 13A), lung (Figure 13B), and spleen (Figure 13C) tissue 6 hours after intravenous administration of PBS (1); 0.5 mg/kg lipid nanoparticle formulations prepared by a control aqueous feed mRNA method (2); and 0.5 mg/kg lipid nanoparticle formulations prepared by methods of the disclosure employing organic feed mRNA T-mixing (3) and 96-well plate high-throughput mixing (4).

[0031] Figures 14A-14D are whole body in vivo imaging system (IVIS) bioluminescence images of mice 24 hours after intravenous administration of PBS (Figure 14A); 0.5 mg/kg lipid nanoparticle formulations prepared by a control aqueous feed mRNA method (Figure 14B); and 0.5 mg/kg lipid nanoparticle formulations prepared by methods of the disclosure employing organic feed mRNA T-mixing (Figure 14C) and 96-well plate high-throughput mixing (Figure 14D).

[0032] Figure 15 is a graph comparing luciferase expression levels in mice (whole body flux) 6 hours after intramuscular dorsal administration of PBS (1); 0.1 mg/kg lipid nanoparticle formulations prepared by a control aqueous feed mRNA method (2); and 0.1 mg/kg lipid nanoparticle formulations prepared by methods of the disclosure employing organic feed mRNA T-mixing (3) and 96-well plate high-throughput mixing (4).

[0033] Figure 16 is a graph comparing luciferase expression levels in mice (whole body flux) 24 hours after intramuscular dorsal administration of PBS (1); 0.1 mg/kg lipid nanoparticle formulations prepared by a control aqueous feed mRNA method (2); and 0.1 mg/kg lipid nanoparticle formulations prepared by methods of the disclosure employing organic feed mRNA T-mixing (3) and 96-well plate high-throughput mixing (4).

[0034] Figures 17A-17D are whole body in vivo imaging system (IVIS) bioluminescence images of mice 6 hours after intramuscular administration of PBS (Figure 17A); 0.1 mg/kg lipid nanoparticle formulations prepared by a control aqueous feed mRNA method (Figure 17B); and 0.1 mg/kg lipid nanoparticle formulations prepared by methods of the disclosure employing organic feed mRNA T-mixing (Figure 17C) and 96-well plate high-throughput mixing (Figure 17D).

[0035] Figures 18A-18D are graphs comparing luciferase expression levels in ex vivo mice injection site (Figure 18A), liver (Figure 18B), lung (Figure 18C), and spleen (Figure 18D) tissue 6 hours after intramuscular administration of PBS (1); 0.1 mg/kg lipid nanoparticle formulations

prepared by a control aqueous feed mRNA method (2); and 0.1 mg/kg lipid nanoparticle formulations prepared by methods of the disclosure employing organic feed mRNA T-mixing (3) and 96-well plate high-throughput mixing (4).

[0036] Figures 19A-19D are ex vivo bioluminescence images of mice lung (1), liver (2), spleen (3), and injection site (4, circled) tissue distribution 6 hours after intramuscular administration of PBS (Figure 19A); 0.1 mg/kg lipid nanoparticle formulations prepared by a control aqueous feed mRNA method (Figure 19B); and 0.1 mg/kg lipid nanoparticle formulations prepared by methods of the disclosure employing organic feed mRNA T-mixing (Figure 19C) and 96-well plate high-throughput mixing (Figure 19D).

[0037] Figures 20A-20D are whole body in vivo imaging system (IVIS) bioluminescence images of mice 24 hours after intramuscular administration of PBS (Figure 20A); 0.1 mg/kg lipid nanoparticle formulations prepared by a control aqueous feed mRNA method (Figure 20B); and 0.1 mg/kg lipid nanoparticle formulations prepared by methods of the disclosure employing organic feed mRNA T-mixing (Figure 20C) and 96-well plate high-throughput mixing (Figure 20D).

[0038] Figures 21A-21D are graphs comparing luciferase expression levels in ex vivo mice injection site (Figure 21A), liver (Figure 21B), lung (Figure 21C), and spleen (Figure 21D) tissue 24 hours after intramuscular administration of PBS (1); 0.1 mg/kg lipid nanoparticle formulations prepared by a control aqueous feed mRNA method (2); and 0.1 mg/kg lipid nanoparticle formulations prepared by methods of the disclosure employing organic feed mRNA T-mixing (3) and 96-well plate high-throughput mixing (4).

[0039] Figures 22A-22D are ex vivo bioluminescence images of mice lung (1), liver (2), spleen (3), and injection site (4, circled) tissue distribution 24 hours after intramuscular administration of PBS (Figure 22A); 0.1 mg/kg lipid nanoparticle formulations prepared by a control aqueous feed mRNA method (Figure 22B); and 0.1 mg/kg lipid nanoparticle formulations prepared by methods of the disclosure employing organic feed mRNA T-mixing (Figure 22C) and 96-well plate high-throughput mixing (Figure 22D).

[0040] Figure 23 is a graph comparing cytokine induction levels (IFN-alpha, IP-10, MCP-1) 6 hours after intramuscular administration of PBS; 0.1 mg/kg lipid nanoparticle formulations prepared by a control aqueous feed mRNA method; and 0.1 mg/kg lipid nanoparticle formulations prepared by methods of the disclosure employing organic feed mRNA T-mixing

and 96-well plate high-throughput mixing. The circles represent PBS, the squares represent aqueous feed mRNA NanoAssemblr (AFM-Na), the up-pointing triangles represent organic feed mRNA T-mix (OFM-Tmix), and the down-pointing triangles represent OFM 96-well.

[0041] Figure 24 is a graph comparing in vitro expression of aqueous feed mRNA NanoAssemblr mixing and organic feed mRNA (OFM) Tmixing and 96-well mixing. The circles represent Aqueous feed mRNA NanoAssemblr (AFM-Na), the squares represent organic feed mRNA T-mix (OFM-Tmix), and the triangles represent OFM 96-well.

[0042] Figure 25 is a graph comparing average particle diameters of lipid nanoparticle formulations prepared by stir plate benchtop vial mixing employing organic soluble mRNA salts of triethylamine (TEA), tripropylamine (TPA), and tributylamine (TBA) prepared by the tangential flow filtration method without lyophilization after initial formation, after dialysis against PBS buffer, and after concentration using centrifugal filter devices.

[0043] Figure 26 is a graph comparing the polydispersity index (PDI) of lipid nanoparticle formulations prepared by stir plate benchtop vial mixing employing organic soluble mRNA salts of triethylamine (TEA), tripropylamine (TPA), and tributylamine (TBA) prepared by the tangential flow filtration method without lyophilization after initial formation, after dialysis against PBS buffer, and after concentration using centrifugal filter devices.

[0044] Figure 27 is a graph comparing the encapsulation efficiency (%EE) of lipid nanoparticle formulations prepared by stir plate benchtop vial mixing employing organic soluble mRNA salts of triethylamine (TEA), tripropylamine (TPA), and tributylamine (TBA) prepared by the tangential flow filtration method without lyophilization as measured by RiboGreen assay.

[0045] Figure 28 is a graph comparing the encapsulation efficiency (%EE) of lipid nanoparticles prepared by mixing an organic feed mRNA stock and lipid mixture with an aqueous phase of 25 mM acetate buffer (pH ~5) or 20 mM tris buffer/8% sucrose (pH ~7.4) or an aqueous feed mRNA stock.

[0046] Figure 29 is a graph comparing expression levels of in vivo bedside lipid nanoparticle formulations at 6 hours.

[0047] Figure 30 is a graph comparing expression levels of in vivo bedside lipid nanoparticle formulations at 24 hours.

[0048] Figure 31 is a graph comparing in vitro expression of aqueous feed mRNA (AFM) NanoAssemblr mixing and 96-well mixing AFM and organic feed mRNA (OFM) 96-well

mixing. The circles represent Aqueous feed mRNA NanoAssemblr (AFM-Na); the squares represent 96-well, pooled-AFM; and the triangles represent 96-well, pooled OFM.

[0049] Figure 32 is a graph comparing in vitro expression of aqueous feed mRNA (AFM) NanoAssemblr mixing and L-syringe mixing AFM and organic feed mRNA (OFM) L-syringe mixing. The dark circles represent NanoAssemblr aqueous feed mRNA (AFM-Na), the light circles represent L-syringe mixing AFM (L-syringe-AFM), and the squares represent L-syringe mixing OFM (L-syringe-OFM).

[0050] Figure 33 is a graph comparing in vitro expression of aqueous feed mRNA (AFM) NanoAssemblr mixing and K-syringe mixing AFM and organic feed mRNA (OFM) K-syringe mixing. The circles represent NanoAssemblr aqueous feed mRNA (AFM-Na), the triangles represent K-syringe mixing AFM (K-syringe-AFM), and the diamonds represent K-syringe mixing OFM (K-syringe-OFM).

[0051] Figure 34 is a graph comparing in vitro expression of aqueous feed mRNA (AFM) NanoAssemblr mixing, 96-well mixing AFM, K-syringe mixing AFM, and L-syringe mixing AFM. The dark circles represent NanoAssemblr aqueous feed mRNA; the squares represent 96-well, pooled-AFM; the triangles represent K-syringe mixing AFM (K-syringe-AFM); and the light circles represent L-syringe mixing AFM (L-syringe-AFM).

[0052] Figure 35 is a graph showing hEPO expression from CD-1 mice at 6 hours on a log scale showing the impact of dosing pH on identical formulations with N:P of 5.8, 4, and 3.

[0053] Figure 36 is a graph showing hEPO expression from CD-1 mice at 6 hours on a linear scale showing the impact of dosing pH on identical formulations with N:P of 5.8, 4, and 3.

[0054] Figure 37 is a graph showing hEPO expression from CD-1 mice at 24 hours on a log scale showing the impact of dosing pH on identical formulations with N:P of 5.8, 4, and 3.

[0055] Figure 38 is a graph showing hEPO expression from CD-1 mice at 24 hours on a linear scale showing the impact of dosing pH on identical formulations with N:P of 5.8, 4, and 3.

[0056] Figures 39A–39C are graphs showing cytokine response from CD-1 mice at 6 hours comparing dosing pH on formulations and N:P ratio.

[0057] Figure 40 shows the structures of higher pKa cations used in example 8 for neutral pH bedside formulation procedures.

[0058] Figure 41 is a graph showing hEPO expression at 6 hours post dosing showing comparability of formulations made using the neutral pH approach to traditional controls. Group

2 was formulated and dosed at pH 5, while group 3 was sample of group 2 neutralized to pH 7.4 prior to dosing. Groups 4 and 5 were made and dosed at pH 7.4.

[0059] Figure 42 is a graph showing expression of hEPO at 24 hours post dosing showing comparability of formulations made using the neutral pH approach to traditional controls. Group 2 was formulated and dosed at pH 5, while group 3 was sample of group 2 neutralized to pH 7.4 prior to dosing. Groups 4 and 5 were made and dosed at pH 7.4.

[0060] Figures 43A–43C are graphs showing cytokine response from CD-1 mice at 6 hours comparing formulation process and high pKa lipid addition.

[0061] Figure 44 is a graph shows the structures of additional high pKa cations tested using the neutral pH formulation process.

[0062] Figure 45 is a graph showing expression of hEPO 6 hours post dosing showing comparability of formulations made using alternative high pKa cations in the EA-III series with the neutral pH bedside nanoprecipitation approach.

[0063] Figure 46 is a graph showing expression of hEPO 24 hours post dosing showing comparability of formulations made using alternative high pKa cations in the EA-III series with the neutral pH bedside nanoprecipitation approach.

[0064] Figures 47A–47B are graphs showing cytokine response from CD-1 mice at 6 hours comparing the impact of high pKa cations across the EA-III series to EA-1 and a traditional LNP control.

[0065] Figure 48 is a graph showing dosing and sample collection schedule.

[0066] Figure 49 is a graph showing dose 2 large particle ($>0.8 \mu\text{m}$) characterization data for bedside groups 3 through 6.

[0067] Figure 50 is a graph showing dose 2 large particle ($>2 \mu\text{m}$) characterization data for bedside groups 3 through 6.

[0068] Figure 51 is a graph showing IgG (Pentamer) titers for groups 1-6 demonstrating immunological responses across all formulations tested, including those generated with the acidic or neutral pH bedside nanoprecipitation procedures.

[0069] Figure 52 is a graph showing IgG (gB) titers for groups 1-6 demonstrating immunological responses across all formulations tested, including those generated with the acidic or neutral pH bedside nanoprecipitation procedures.

[0070] Figure 53 is a graph showing dosing and sample collection schedule.

[0071] Figure 54 is a graph showing class I responses for CA-A, CA-B, and CA-C restimulations observed for control and bedside nanoprecipitated formulations using neutral or acidic conditions.

[0072] Figure 55 is a graph showing class II responses for CA-D and CA-E restimulations observed for control and bedside nanoprecipitated formulations using neutral or acidic conditions.

[0073] Figure 56 is a graph showing whole body luminescence 6 hr post dose.

[0074] Figure 57 is a graph showing ex-vivo liver luminescence 6 hr post dose.

[0075] Figure 58 is a graph showing ex-vivo spleen luminescence 6 hr post dose.

[0076] Figure 59 is a graph ex-vivo lung luminescence 6 hr post dose.

[0077] Figure 60 shows the structure of high pKa lipid (EA-13) used in example 13.

[0078] Figure 61 is a graph showing hEPO concentrations 6 hr post dose.

[0079] Figure 62 is a graph showing hEPO concentrations 24 hr post dose.

[0080] Figure 63 is a graph showing IP-10 levels 6 hr post dose.

[0081] Figure 64 is a graph showing MCP-1 levels 6 hr post dose.

Detailed Description

[0082] The present disclosure is based, in part, on the discovery that the method of producing the lipid nanoparticle (LNP) formulation, as disclosed herein, can influence and/or dictate physical (e.g., LNP stability), chemical (e.g., nucleic acid stability), and/or biological (e.g. efficacy, intracellular delivery, immunogenicity) properties of the LNP formulation.

[0083] In some embodiments, the method of the present disclosure mitigates an undesired property change from the produced lipid nanoparticle (LNP) formulation. In some embodiments, the method of the present disclosure mitigates an undesired property change from the produced lipid nanoparticle (LNP) formulation as compared to the LNP formulation produced by a comparable method (e.g., a method without one or more of the steps as disclosed herein).

[0084] In some embodiments, the undesired property change caused by a stress upon the LNP formulation or the LNP therein. In some embodiments, the stress is induced during producing, purifying, packing, storing, transporting, and/or using the LNP formulation. In some embodiments, the stress is heat, shear, excessive agitation, membrane concentration polarization (change in charge state), dehydration, freezing stress, drying stress, freeze/thaw stress, and/or

nebulization stress. In some embodiments, the stress is induced during freezing or lyophilizing a LNP formulation.

[0085] In some embodiments, the undesired property change is a reduction of the physical stability of the LNP formulation. In some embodiments, the undesired property change is an increase of the amount of impurities and/or sub-visible particles, or an increase in the average size of the LNP in the LNP formulation.

[0086] In some embodiments, the method of the present disclosure mitigates a reduction of the physical stability (e.g., an increase in the average size of the LNP) from the produced LNP formulation as compared to the LNP formulation produced by a comparable method as disclosed herein.

[0087] In some embodiments, the LNP formulation produced by the method of the present disclosure has an average LNP diameter being about 99% or less, about 98% or less, about 97% or less, about 96% or less, about 95% or less, about 90% or less, about 85% or less, about 80% or less, about 75% or less, about 70% or less, about 65% or less, about 60% or less, about 55% or less, about 50% or less, about 40% or less, about 30% or less, about 20% or less, or about 10% or less as compared to the average LNP diameter of the LNP formulation produced by a comparable method as disclosed herein.

[0088] In some embodiments, the undesired property change is a reduction of the chemical stability of the LNP formulation. In some embodiments, the undesired property change is a reduction of the integrity of the nucleic acid (e.g., RNA (e.g., mRNA)) in the LNP formulation.

[0089] In some embodiments, the undesired property change is a reduction of the biological property of the LNP formulation. In some embodiments, the undesired property change is a reduction of efficacy, intracellular delivery, and/or immunogenicity of the LNP formulation.

[0090] In some embodiments, the LNP formulation produced by the method of the present disclosure has an efficacy, intracellular delivery, and/or immunogenicity being higher than the efficacy, intracellular delivery, and/or immunogenicity of the LNP formulation produced by a comparable method as disclosed herein.

[0091] In some embodiments, the LNP formulation produced by the method of the present disclosure has an efficacy, intracellular delivery, and/or immunogenicity being higher than the efficacy, intracellular delivery, and/or immunogenicity of the LNP formulation produced by a comparable method by about 5% or higher, about 10% or more, about 15% or more, about 20%

or more, about 30% or more, about 40% or more, about 50% or more, about 60% or more, about 70% or more, about 80% or more, about 90% or more, about 1 folds or more, about 2 folds or more, about 3 folds or more, about 4 folds or more, about 5 folds or more, about 10 folds or more, about 20 folds or more, about 30 folds or more, about 40 folds or more, about 50 folds or more, about 100 folds or more, about 200 folds or more, about 300 folds or more, about 400 folds or more, about 500 folds or more, about 1000 folds or more, about 2000 folds or more, about 3000 folds or more, about 4000 folds or more, about 5000 folds or more, or about 10000 folds or more.

[0092] In some embodiments, the LNP formulation produced by the method of the present disclosure exhibits a nucleic acid expression (e.g., the mRNA expression) higher than the nucleic acid expression (e.g., the mRNA expression) of the LNP formulation produced by a comparable method.

[0093] In some embodiments, the LNP formulation produced by the method of the present disclosure exhibits a nucleic acid expression (e.g., the mRNA expression) higher than the nucleic acid expression (e.g., the mRNA expression) of the LNP formulation produced by a comparable method by about 5% or higher, about 10% or more, about 15% or more, about 20% or more, about 30% or more, about 40% or more, about 50% or more, about 60% or more, about 70% or more, about 80% or more, about 90% or more, about 1 folds or more, about 2 folds or more, about 3 folds or more, about 4 folds or more, about 5 folds or more, about 10 folds or more, about 20 folds or more, about 30 folds or more, about 40 folds or more, about 50 folds or more, about 100 folds or more, about 200 folds or more, about 300 folds or more, about 400 folds or more, about 500 folds or more, about 1000 folds or more, about 2000 folds or more, about 3000 folds or more, about 4000 folds or more, about 5000 folds or more, or about 10000 folds or more.

Methods of Producing and Methods of Administering Lipid Nanoparticle (LNP)

Formulations

[0094] The present invention overcomes some of the limitations brought on by complex mixing used in traditional lipid nanoparticle (LNP) formation processes by pre-combining the oligonucleotide and lipid components in the organic phase prior to the introduction of the aqueous phase in the LNP formation process. This is achieved using mRNA whose solubility

has been altered through ion pairing to make it soluble in organic solutions compatible with traditional LNP formation processes. Creating mRNA salts where the cation associated with the phosphate backbone is a hydrophobic organic molecule, converts the solubility profile of the mRNA from being highly water soluble, to something now soluble in organic solvents and solvent mixtures with high ethanol content. In contrast to traditional procedures, this enables the dissolution of oligonucleotide payloads directly with the hydrophobic lipid and cationic lipid components of the LNP in the organic phase prior to mixing with the aqueous phase during LNP formation.

[0095] Typical lipid nanoparticle (LNP) formation procedures involve the controlled mixing of hydrophobic lipid components dissolved in an organic solvent such as ethanol with an aqueous buffer solution containing the oligonucleotide to be loaded into the resulting particle. Due to the complexity of mixing, and the various ionic interactions necessary to successfully entrap the oligonucleotide in the particle core, there are a large number of variables at play throughout the particle forming process which can impact the quality, stability, and function of the resultant particle.

[0096] This invention simplifies the LNP formation process by combining the mRNA or other oligonucleotide with the lipid components in the organic solvent phase prior to mixing with the aqueous phase. Organic solvent soluble mRNA (OSSM) ensures that the condensing cationic lipids have free access to the mRNA throughout the entire mixing process, and prevents the need for mRNA to partition into the hydrophobic environment or be coated with hydrophobic components during mixing to allow incorporation into the LNP core. This is expected to reduce the complexities associated with the controlled mixing process, generate a more dehydrated LNP core, and provide for more compositional flexibility around LNP surface parameters, as the mRNA is starting from the organic phase, a more dehydrated state. This additional dehydration should have beneficial effects for particle stability and mRNA chemical stability within the formulation, while the reduced burden on mixing and transition of the payload out of the bulk aqueous phase should simplify the formulation process.

[0097] In addition to the simplification of mixing, it is expected that the oligonucleotide residence in the organic phase with the hydrophobic components which make up the core of the LNP prior to introduction of the aqueous phase, would enable more flexibility in LNP surface by removing the need for the oligo payload to transfer from the aqueous phase to the LNP core.

Molecules such as PEGylated lipids at high density can create steric barriers for mRNA exchange under traditional formation techniques when the oligonucleotide is fed from the aqueous phase. OSSM ensures the mRNA is already in close proximity to the hydrophobic components of the LNP before the aqueous phase introduction, enabling an increased flexibility in LNP composition, especially for LNP surface modifying components.

[0098] The invention involves the process of enabling the formation of LNPs using mRNA dissolved in the organic solvent phase. The first step involves the conversion of the water-soluble sodium salt form of mRNA to the organic solvent soluble mRNA (OSSM) form. The next step is the dissolution of the OSSM in organic solvent or solvent mixtures to enable LNP formation with the organic solution fed mRNA.

[0099] Water soluble forms of mRNA, like sodium salts, are dissolved in water. This solution is combined with a buffer solution where the basic portion of the buffer is comprised of an organic compound with increased organic solubility. This solution is then treated with a buffer exchange process to eliminate residual inorganic cations from the solution, and leave only the desired hydrophobic cation present to interact with the phosphate backbone of the mRNA.

[00100] This process can be accomplished in a number of ways. In some embodiments, the mRNA solution is processed using tangential flow filtration by exchanging the mRNA solution with buffer to drive the cation exchange to the hydrophobic cation. After the buffer exchange step, the mRNA solution may be further exchanged with of ddH₂O to remove excess buffer, leaving the mRNA in solution in the hydrophobic cation salt form. This solution may then be concentrated by tangential flow filtration (TFF), and dried through evaporation or lyophilization to afford the material for dissolution in the organic phase needed for the LNP process.

[00101] In some embodiments, dialysis is used to convert the water-soluble mRNA to the hydrophobic salt form. In this embodiment, the starting mRNA solution is dissolved in buffer whose basic component is the hydrophobic organic cation. The mRNA is then dialyzed against addition buffer to drive the cation exchange process with additional buffer replacements. The mRNA containing solution may then be dialyzed against ddH₂O to remove the excess buffer while leaving the desired salt form of mRNA. After the dialysis in water, the mRNA solution may be dried through evaporation or lyophilization to afford the material for dissolution in the organic phase needed for the LNP process.

[00102] In some embodiments, a hydrophobic ion pairing reverse phase method is used to create the desired hydrophobic salt form of mRNA. In this procedure, the mRNA may be bound to a reverse phase support using a hydrophobic ion pairing approach. The mRNA may then be eluted off the reverse phase column with a combination of organic solvent and aqueous buffer whose cationic portion is a hydrophobic organic molecule. The resulting fractions containing the mRNA may be further dried to afford the mRNA in a desired hydrophobic cation form. The method is particularly useful in that the process of creating the hydrophobic salt of the mRNA that can be incorporated into reverse phase purification techniques commonly used in the production and purification of an mRNA and other oligonucleotide constructs.

[00103] In another embodiment, an ion exchange resin can be used to convert the mRNA from the water-soluble cation salt form to a hydrophobic salt form. For this procedure, the ion exchange resin is loaded with the desired hydrophobic cation, and treated with the mRNA solution to afford desired hydrophobic salt form of the mRNA. The mRNA solution is dried through evaporation or lyophilization to afford the material for dissolution in the organic phase needed for the LNP process.

[00104] In another embodiment, the hydrophobic cation can be added to the mRNA using a size exclusion column preequilibrated with a buffer containing the hydrophobic cation. The mRNA solution is dried through evaporation or lyophilization to afford the material for dissolution in the organic phase needed for the LNP process.

[00105] In some embodiments, appropriate molecular weight centrifugation devices can be used to exchange the cation on mRNA to a more hydrophobic and organic soluble one. The mRNA solution containing the water-soluble cation salt of mRNA is diluted with a buffer containing the desired hydrophobic cation as the basic component of the buffer. Repeated concentration and dilution with the exchange buffer steps, followed by optional exchanges with ddH₂O results in the desired hydrophobic salt form of the mRNA. The mRNA solution is dried through evaporation or lyophilization to afford the material for dissolution in the organic phase needed for the LNP process.

[00106] Once the hydrophobic salt form of the mRNA is dried, the material can be dissolved in organic solutions to enable LNP formulation.

[00107] In some embodiments, the organic solvent soluble mRNA (OSSM) is directly dissolved in the desired organic solvent such as mRNA.

[00108] In some embodiments, the OSSM is first dissolved in a small amount of organic solvent such as benzyl alcohol to facilitate wetting and dissolution of the hydrophobic mRNA salt, followed by dilution with the desired solvent for use in the bulk phase such as ethanol to result in a mixed organic solvent system.

[00109] This solution can be combined with cationic lipids, helper lipids, PEGylated lipids to generate an organic solution of mRNA and lipids suitable for LNP production.

[00110] The organic solution of mRNA and lipids can be precipitated into aqueous buffers such as acetate buffer pH 5 to ensure protonation of the desired cationic lipid components and promote the cation exchange with mRNA and displace the hydrophobic cation used to create the initial organic soluble mRNA material.

[00111] The organic solution of mRNA and lipids can be mixed using a microfluidics or T mixing approach with aqueous buffers such as acetate buffer pH 5 to ensure protonation of the desired cationic lipid components and promote the cation exchange with mRNA and displace the hydrophobic cation used to create the initial organic soluble mRNA material.

[00112] The present disclosure is based, in part, on the discovery that the method of producing the lipid nanoparticle can influence distribution of certain components within the lipid nanoparticles, and that this distribution can influence and/or dictate physical (e.g., stability) and/or biological (e.g. efficacy, intracellular delivery, immunogenicity) properties of the lipid nanoparticles.

[00113] In this disclosure, methods are described that yield compositions comprising lipid nanoparticles having an advantageous distribution of components.

[00114] Advantageously, organic soluble mRNA and/or aqueous-soluble mRNA could enable bedside formulation of mRNA LNPs. The mRNA stored in an unformulated state should offer significant storage and stability advantages, while cation pKa and formulation parameters can be used to reduce or eliminate the need for buffering or pH adjustment during formulation.

Providing LNP Solutions

[00115] In some aspects, the present disclosure provides a method of producing a lipid nanoparticle (LNP) formulation, comprising: (i) providing a LNP solution comprising a lipid nanoparticle (LNP), wherein the LNP comprises a nucleic acid and an ionizable lipid; and (ii) processing the LNP solution, thereby forming the LNP formulation.

[00116] In some aspects, the present disclosure provides a method of producing a lipid nanoparticle (LNP) composition, the method comprising: (i) mixing an aqueous buffer solution and an organic solution, thereby forming a lipid nanoparticle (LNP) formulation comprising a lipid nanoparticle (LNP) encapsulating a nucleic acid; and (ii) processing the lipid nanoparticle (LNP) formulation, thereby forming the lipid nanoparticle composition; wherein the organic solution comprises an organic solvent-soluble nucleic acid and an ionizable lipid in an organic solvent; and wherein the organic solvent-soluble nucleic acid comprises a hydrophobic organic cation.

[00117] Suitable nucleic acids for the method of the present disclosure are further disclosed herein. In some embodiments, the nucleic acid is an RNA (e.g., mRNA).

[00118] Suitable ionizable lipids for the methods of the present disclosure are further disclosed herein.

[00119] In some embodiments, the LNP further comprises a phospholipid, a PEG lipid, a structural lipid, or any combination thereof. Suitable phospholipids, PEG lipids, and structural lipids for the methods of the present disclosure are further disclosed herein.

[00120] In some embodiments, the step of providing the LNP solution comprises mixing an aqueous buffer solution and an organic solution wherein the organic solution comprises an organic solvent-soluble nucleic acid and an ionizable lipid in an organic solvent; and wherein the organic solvent-soluble nucleic acid comprises a hydrophobic organic cation.

[00121] In some embodiments, the step of providing the LNP solution comprises:
ia) converting a water-soluble salt of a nucleic acid to an organic solvent-soluble nucleic acid prior to the mixing, thereby forming the organic solvent-solvent soluble nucleic acid.

[00122] In some embodiments, the step of providing the LNP solution comprises:
iaa) lyophilizing the organic solvent-soluble nucleic acid after the converting.

[00123] In some embodiments, the converting comprises a dialysis.

[00124] In some embodiments, the converting comprises a tangential flow filtration (TFF).

[00125] In some embodiments, the converting comprises employing a hydrophobic ion pairing reverse phase column.

[00126] In some embodiments, the converting comprises employing an ion exchange resin.

[00127] In some embodiments, the converting comprises employing a size exclusion column.

- [00128] In some embodiments, the organic solvent-soluble nucleic acid is a tertiary amine salt.
- [00129] In some embodiments, the organic solvent-soluble nucleic acid is a tributylamine (TBA) salt.
- [00130] In some embodiments, the organic solvent-soluble nucleic acid is a tripropylamine (TPA) salt.
- [00131] In some embodiments, the organic solvent-soluble nucleic acid is a trimethylamine (TEA) salt.
- [00132] In some embodiments, wherein the water-soluble salt of a nucleic acid a sodium salt.
- [00133] In some embodiments, the water-soluble salt of a nucleic acid is a tris(hydroxymethyl)aminomethane (Tris) salt.
- [00134] In some embodiments, the organic solvent is an alcohol.
- [00135] In some embodiments, the organic solvent is ethanol.
- [00136] In some embodiments, the organic solvent comprises a first organic solvent and a second organic solvent.
- [00137] In some embodiments, the first organic solvent is an alcohol and the second organic solvent is an alcohol.
- [00138] In some embodiments, the first organic solvent is ethanol and the second organic solvent is benzyl alcohol.
- [00139] In some embodiments, wherein a wt/wt ratio of the first organic solvent to the second organic solvent is in a range of from about 100:1 to about 1:1.
- [00140] In some embodiments, a wt/wt ratio of the first organic solvent to the second organic solvent is in a range of from about 50:1 to about 1:1.
- [00141] In some embodiments, a wt/wt ratio of the first organic solvent to the second organic solvent is in a range of from about 20:1 to about 1:1.
- [00142] In some embodiments, a wt/wt ratio of the first organic solvent to the second organic solvent is in a range of from about 10:1 to about 1:1.
- [00143] In some embodiments, the aqueous buffer solution has a pH in a range of from about 4 to about 6.
- [00144] In some embodiments, the aqueous buffer solution has a pH in a range of from about 4.5 to about 5.5.

[00145] In some embodiments, the aqueous buffer solution has a pH in a range of from about 4.8 to about 5.2.

[00146] In some embodiments, the aqueous buffer solution has a pH in a range of from about 4 to about 6, about 4.5 to about 5.5, or about 4.8 to about 5.2.

[00147] In some embodiments, the organic solution has a pH in a range of from about 7.0 to about 9.0, about 7.0 to about 8.1, or about 7.1 to about 7.8, or about 7.2 to about 7.7, or about 7.3 to about 7.6, or about 7.4 to about 7.5

[00148] In some embodiments, the aqueous buffer solution is an acetate buffer.

[00149] In some embodiments, the mixing comprises turbulent mixing.

[00150] In some embodiments, the mixing comprises laminar mixing.

[00151] In some embodiments, the mixing comprises microfluidic mixing.

[00152] In some embodiments, the mixing is performed by a NanoAssemblTM.

[00153] In some embodiments, the mixing is not turbulent and has a Reynolds number of less than 5.0×10^4 .

[00154] In some embodiments, the mixing is not turbulent and has a Reynolds number of less than 1.0×10^4 .

[00155] In some embodiments, the mixing is not turbulent and has a Reynolds number of less than 5.0×10^3 .

[00156] In some embodiments, the mixing is not turbulent and has a Reynolds number of less than 2.5×10^3 .

[00157] In some embodiments, the mixing has a Reynolds number of less than 5.0×10^4 , less than 1.0×10^4 , less than 5.0×10^3 , or less than 2.5×10^3 .

[00158] In some embodiments, the mixing has a Reynolds number of less than about 1000, less than about 500, or less than about 250.

Processing LNP Solutions

[00159] The term “processing”, as used herein, includes one or more steps to purify, pH adjust, buffer exchange, and/or concentrate LNPs.

[00160] In some embodiments, the step of processing the LNP solution comprises:

- ii) filtering the LNP solution.

[00161] In some embodiments, the filtration removes an organic solvent (e.g., an alcohol or ethanol) from the LNP solution. In some embodiments, the processing comprises a tangential flow filtration (TFF). In some embodiments, upon removal of the organic solvent (e.g. an alcohol or ethanol), the LNP solution is converted to a solution buffered at a neutral pH, pH 6.5 to 7.8, pH 6.8 to pH 7.5, preferably, pH 7.0 to pH 7.2 (e.g., a phosphate or HEPES buffer). In some embodiments, the resulting LNP solution is preferably sterilized before storage or use, e.g., by filtration (e.g., through a 0.1-0.5 μm filter).

[00162] In some embodiments, the step of processing the LNP solution further comprises packing the LNP solution.

[00163] As used herein, “packing” may refer to storing a drug product in its final state or in-process storage of LNPs before they are placed into final packaging. Modes of storage and/or packing include, but are not limited to, refrigeration in sterile bags, refrigerated or frozen formulations in vials, lyophilized formulations in vials and syringes, etc.

[00164] In some embodiments, the step of packing the LNP solution comprises one or more of the following steps:

- ii) adding a cryoprotectant to the LNP solution;
- iii) lyophilizing the LNP solution, thereby forming a lyophilized LNP composition;
- iv) storing the LNP solution of the lyophilized LNP composition; and
- v) adding a buffering solution to the LNP solution or the lyophilized LNP composition, thereby forming the LNP formulation.

[00165] In some embodiments, the cryoprotectant is added to the LNP solution prior to the lyophilization. In some embodiments, the cryoprotectant comprises one or more cryoprotective agents, and each of the one or more cryoprotective agents is independently a polyol (e.g., a diol or a triol such as propylene glycol (i.e., 1,2-propanediol), 1,3-propanediol, glycerol, (+/-)-2-methyl-2,4-pentanediol, 1,6-hexanediol, 1,2-butanediol, 2,3-butanediol, ethylene glycol, or diethylene glycol), a nondetergent sulfobetaine (e.g., NDSB-201 (3-(1-pyridino)-1-propane sulfonate), an osmolyte (e.g., L-proline or trimethylamine N-oxide dihydrate), a polymer (e.g., polyethylene glycol 200 (PEG 200), PEG 400, PEG 600, PEG 1000, PEG 3350, PEG 4000, PEG 8000, PEG 10000, PEG 20000, polyethylene glycol monomethyl ether 550 (mPEG 550), mPEG 600, mPEG 2000, mPEG 3350, mPEG 4000, mPEG 5000, polyvinylpyrrolidone (e.g., polyvinylpyrrolidone K 15), pentaerythritol propoxylate, or polypropylene glycol P 400), an

organic solvent (e.g., dimethyl sulfoxide (DMSO) or ethanol), a sugar (e.g., D-(+)-sucrose, D-sorbitol, trehalose, D-(+)-maltose monohydrate, meso-erythritol, xylitol, myo-inositol, D-(+)-raffinose pentahydrate, D-(+)-trehalose dihydrate, or D-(+)-glucose monohydrate), or a salt (e.g., lithium acetate, lithium chloride, lithium formate, lithium nitrate, lithium sulfate, magnesium acetate, sodium chloride, sodium formate, sodium malonate, sodium nitrate, sodium sulfate, or any hydrate thereof), or any combination thereof. In some embodiments, the cryoprotectant comprises sucrose.

[00166] In some embodiments, the lyophilization is carried out in a suitable glass receptacle (e.g., a 10 mL cylindrical glass vial). The glass receptacle preferably withstand extreme changes in temperatures between lower than $-40\text{ }^{\circ}\text{C}$ and higher than room temperature in short periods of time, and/or be cut in a uniform shape. In some embodiments, the step of lyophilizing comprises freezing the LNP solution at a temperature higher than about $-40\text{ }^{\circ}\text{C}$ and, preferably, lower than about $-30\text{ }^{\circ}\text{C}$, thereby forming a frozen LNP solution; and drying the frozen LNP solution to form the lyophilized LNP composition. The freezing step preferably results in a linear decrease in temperature to the final over about 6 minutes, preferably at about $1\text{ }^{\circ}\text{C}$ per minute from $20\text{ }^{\circ}\text{C}$ to $-40\text{ }^{\circ}\text{C}$. In some embodiments, sucrose at 12-15% may be used, and the drying step is performed at a vacuum ranging from about 50 mTorr to about 150 mTorr, preferably, first at a low temperature ranging from about $-35\text{ }^{\circ}\text{C}$ to about $-15\text{ }^{\circ}\text{C}$, and then at a higher temperature ranging from room temperature to about $25\text{ }^{\circ}\text{C}$, and preferably, the drying step is completed in three to seven days. In some embodiments, the drying step is performed at a vacuum ranging from about 50 mTorr to about 100 mTorr, preferably, first at a low temperature ranging from about $-15\text{ }^{\circ}\text{C}$ to about $0\text{ }^{\circ}\text{C}$, and then at a higher temperature.

[00167] In some embodiment, the LNP solution or the lyophilized LNP composition is stored at a temperature of about $-40\text{ }^{\circ}\text{C}$, about $-35\text{ }^{\circ}\text{C}$, about $-30\text{ }^{\circ}\text{C}$, about $-25\text{ }^{\circ}\text{C}$, about $-20\text{ }^{\circ}\text{C}$, about $-15\text{ }^{\circ}\text{C}$, about $-10\text{ }^{\circ}\text{C}$, about $-5\text{ }^{\circ}\text{C}$, about $0\text{ }^{\circ}\text{C}$, about $5\text{ }^{\circ}\text{C}$, about $10\text{ }^{\circ}\text{C}$, about $15\text{ }^{\circ}\text{C}$, about $20\text{ }^{\circ}\text{C}$, or about $25\text{ }^{\circ}\text{C}$ prior to adding the buffering solution.

[00168] In some embodiments, the LNP solution or the lyophilized LNP composition is stored at a temperature of ranging from about $-40\text{ }^{\circ}\text{C}$ to about $0\text{ }^{\circ}\text{C}$, from about $-35\text{ }^{\circ}\text{C}$ to about $-5\text{ }^{\circ}\text{C}$, from about $-30\text{ }^{\circ}\text{C}$ to about $-10\text{ }^{\circ}\text{C}$, from about $-25\text{ }^{\circ}\text{C}$ to about $-15\text{ }^{\circ}\text{C}$, from about $-22\text{ }^{\circ}\text{C}$ to about $-18\text{ }^{\circ}\text{C}$, or from about $-21\text{ }^{\circ}\text{C}$ to about $-19\text{ }^{\circ}\text{C}$ prior to adding the buffering solution.

[00169] In some embodiments, the LNP solution or the lyophilized LNP composition is stored at a temperature of about -20 °C prior to adding the buffering solution.

Administering LNP formulations

[00170] In one aspect, the present disclosure relates to a method of administering a lipid nanoparticle (LNP) formulation to a patient, the method comprising: (i) providing an aqueous solution having a first pH in a range of from about 7.0 to about 9.0 comprising a therapeutic and/or prophylactic agent in an aqueous buffer and an organic solution comprising an ionizable lipid and an encapsulation agent in an organic solvent; (ii) forming a lipid nanoparticle formulation comprising a lipid nanoparticle encapsulating the therapeutic and/or prophylactic agent by mixing the aqueous solution and the organic solution such that the lipid nanoparticle formulation has a second pH in a range of from about 7.0 to about 9.0 and comprises at least 1% by volume of the organic solvent relative to the total volume of the lipid nanoparticle formulation; and (iii) administering the lipid nanoparticle formulation to the patient less than about 72 hours after the mixing.

[00171] In one aspect, the present disclosure relates to a method of administering a lipid nanoparticle (LNP) formulation to a patient, the method comprising: (i) providing an aqueous solution having a first pH in a range of from about 4.5 to about less than 7.0 comprising a therapeutic and/or prophylactic agent in an aqueous buffer and an organic solution comprising an ionizable lipid in an organic solvent; (ii) forming a lipid nanoparticle formulation comprising a lipid nanoparticle encapsulating the therapeutic and/or prophylactic agent by mixing the aqueous solution and the organic solution such that the lipid nanoparticle formulation has a second pH in a range of from about 4.5 to about less than 7.0 and comprises at least 1% by volume of the organic solvent relative to the total volume of the lipid nanoparticle formulation; and (iii) administering the lipid nanoparticle formulation to the patient less than about 72 hours after the mixing.

[00172] In one aspect, the present disclosure relates to A method of administering a lipid nanoparticle (LNP) formulation to a patient, the method comprising: (i) providing an aqueous buffer solution having a first pH in a range of from about 7.0 to about 9.0 and an organic solution comprising an ionizable lipid, an encapsulation agent, and a therapeutic and/or prophylactic agent in an organic solvent; (ii) forming a lipid nanoparticle formulation comprising a lipid

nanoparticle encapsulating the therapeutic and/or prophylactic agent by mixing the aqueous buffer solution and the organic solution such that the lipid nanoparticle formulation has a second pH in a range of from about 7.0 to about 9.0 and comprises at least about 1% by volume of the organic solvent relative to the total volume of the lipid nanoparticle formulation; and (iii) administering the lipid nanoparticle formulation to the patient less than about 72 hours after the mixing.

[00173] In one aspect, the present disclosure relates to a method of administering a lipid nanoparticle (LNP) formulation to a patient, the method comprising: (i) providing an aqueous buffer solution having a first pH in a range of from about 4.5 to about less than 7.0 and an organic solution comprising an ionizable lipid and a therapeutic and/or prophylactic agent in an organic solvent; (ii) forming a lipid nanoparticle formulation comprising a lipid nanoparticle encapsulating the therapeutic and/or prophylactic agent by mixing the aqueous buffer solution and the organic solution such that the lipid nanoparticle formulation has a second pH in a range of from about 4.5 to about less than 7.0 and comprises at least 1% by volume of the organic solvent relative to the total volume of the lipid nanoparticle formulation; and (iii) administering the lipid nanoparticle formulation to the patient less than about 72 hours after the mixing.

[00174] In some embodiments, the first pH and the second pH are in a range of from about 7.0 to about 8.1, or about 7.1 to about 7.8, or about 7.2 to about 7.7, or about 7.3 to about 7.6, or about 7.4 to about 7.5.

[00175] In some embodiments, the first pH and the second pH are in a range of from about 4.5 to about 6.5, or about 4.6 to about 6.0, or about 4.8 to about 5.5.

[00176] In some embodiments, the administering is performed less than about 72 hours after the mixing, preferably less than about 60 hours after the mixing, preferably less than about 48 hours after the mixing, preferably less than about 36 hours after the mixing, preferably less than about 24 hours after the mixing, preferably less than about 20 hours after the mixing, preferably less than about 16 hours after the mixing, preferably less than about 12 hours after the mixing, preferably less than about 8 hours after the mixing.

[00177] In some embodiments, the administering is performed less than about 120 minutes after the mixing, preferably less than about 100 minutes after the mixing, preferably less than about 90 minutes after the mixing, preferably less than about 80 minutes after the mixing, preferably less than about 70 minutes after the mixing, preferably less than about 60 minutes

after the mixing, preferably less than about 50 minutes after the mixing, preferably less than about 40 minutes after the mixing, preferably less than about 30 minutes after the mixing, preferably less than about 20 minutes after the mixing, preferably less than about 15 minutes after the mixing, preferably less than about 10 minutes after the mixing.

[00178] In some embodiments, the lipid nanoparticle formulation is not processed between the mixing and the administering.

[00179] In some embodiments, the method of the present disclosure does not comprise a pH adjustment between the mixing and the administering.

[00180] In some embodiments, the lipid nanoparticle formulation is not filtered between the mixing and the administering.

[00181] In some embodiments, the method further comprises receiving at a first inlet of a mixing and administration device the organic solution.

[00182] In some embodiments, the method further comprises receiving at a second inlet of a mixing and administration device the aqueous buffer solution.

[00183] In some embodiments, the mixing is performed at a mixer site of a mixing and administration device.

[00184] In some embodiments, the lipid nanoparticle formulation is administered via an outlet of a mixing and administration device.

[00185] In some embodiments, the providing, the forming, the mixing and the administering are all performed employing a single mixing and administration device, preferably a fluidly connected mixing and administration device.

[00186] In some embodiments, the mixing and administration device comprises a double-barrel syringe.

[00187] In some embodiments, the mixing and administration device comprises a least one selected from the group consisting of a K-syringe and a L-syringe.

[00188] In some embodiments, the mixing and administration device comprises a static mixer at the mixer site.

[00189] In some embodiments, the static mixer is a helical static mixer.

[00190] In some embodiments, the pH of the aqueous buffer solution and the pH of the lipid nanoparticle formulation are about the same.

[00191] In some embodiments, the lipid nanoparticle formulation comprises about 1% by volume to about 50% by volume of the organic solvent relative to the total volume of the lipid nanoparticle formulation, preferably about 2% by volume to about 45% by volume, preferably about 3% by volume to about 40% by volume, preferably about 4% by volume to about 35% by volume, preferably about 5% by volume to about 33% by volume of the organic solvent relative to the total volume of the lipid nanoparticle formulation.

[00192] In some embodiments, the organic solvent is an alcohol.

[00193] In some embodiments, the organic solvent is ethanol.

[00194] In some embodiments, the organic solvent comprise a first organic solvent and a second organic solvent.

[00195] In some embodiments, the first organic solvent is an alcohol and the second organic solvent is an alcohol.

[00196] In some embodiments, the first organic solvent is ethanol and the second organic solvent is benzyl alcohol.

[00197] In some embodiments, a wt/wt ratio of the first organic solvent to the second organic solvent is in a range of from about 100:1 to about 1:1, or about 50:1 to about 1:1, or about 20:1 to about 1:1, or about 10:1 to about 1:1.

[00198] In some embodiments, the organic solution further comprises a wetting agent. As used herein, a wetting agent may refer to an agent that increases, decreases or improves the ability of a liquid to maintain contact with a surface, such as a solid surface and/or liquid surface.

[00199] In some embodiments, the wetting agent is an organic solvent.

[00200] In some embodiments, the wetting agent is dimethyl sulfoxide (DMSO).

[00201] In some embodiments, a wt/wt ratio of the wetting agent to the organic solvent is in a range of from about 1000:1 to about 1:1, or about 500:1 to about 5:1, or about 100:1 to about 10:1.

[00202] In some embodiments, the aqueous buffer solution is at least one selected from the group consisting of an acetate buffer, citrate buffer, phosphate buffer, and a tris buffer. In some embodiments, the aqueous buffer solution may be any buffer suitable for maintaining a physiological pH. In some embodiments, the aqueous buffer solution may be any buffer suitable for maintaining a pH suitable for administering to a patient, preferably a mammalian patient, preferably a human patient.

[00203] In some embodiments, the aqueous buffer solution further comprises a tonicity agent. As used herein, a tonicity agent may refer to an agent that increases, decreases, or improves the effective osmotic pressure gradient, as defined by the water potential of two solutions, or a relative concentration of solutes dissolve in solution impacting the direction and extent of diffusion.

[00204] In some embodiments, the tonicity agent is a sugar.

[00205] In some embodiments, the sugar is sucrose.

LNP Formulations

[00206] In some aspects, the LNP formulation of the present disclosure is prepared by a method disclosed herein.

[00207] In some aspects, the LNP formulation of the present disclosure comprises a plurality of LNPs, wherein the LNPs comprise a nucleic acid and an ionizable lipid.

[00208] Suitable nucleic acids for the methods of the present disclosure are further disclosed herein. In some embodiments, the nucleic acid is RNA (e.g., mRNA).

[00209] Suitable ionizable lipids for the methods of the present disclosure are further disclosed herein.

[00210] In some embodiments, the LNP further comprises a phospholipid, a PEG lipid, a structural lipid, or any combination thereof. Suitable phospholipids, PEG lipids, and structural lipids for the methods of the present disclosure are further disclosed herein.

[00211] In some embodiments, the LNP formulation of the disclosure includes at least one lipid nanoparticle component. Lipid nanoparticles may include a lipid component and one or more additional components, such as a therapeutic and/or prophylactic, such as a nucleic acid. A LNP may be designed for one or more specific applications or targets. The elements of a LNP may be selected based on a particular application or target, and/or based on the efficacy, toxicity, expense, ease of use, availability, or other feature of one or more elements. Similarly, the particular formulation of a LNP may be selected for a particular application or target according to, for example, the efficacy and toxicity of particular combination of elements. The efficacy and tolerability of a LNP formulation may be affected by the stability of the formulation.

[00212] The lipid component of a LNP may include, for example, a lipid according to Formula (IL-I), (IL-IA), (IL-IB), (IL-II), (IL-IIa), (IL-IIb), (IL-IIc), (IL-IId), (IL-IIe), (IL-IIf),

(IL-IIg), (IL-III), (IL-IIIa1), (IL-IIIa2), (IL-IIIa3), (IL-IIIa4), (IL-IIIa5), (IL-IIIa6), (IL-IIIa7), or (IL-IIIa8), a phospholipid (such as an unsaturated lipid, *e.g.*, DOPE or DSPC), a PEG lipid, and a structural lipid. The lipid component of a LNP may include, for example, a lipid according to Formula (IL-I), (IL-IA), (IL-IB), (IL-II), (IL-IIa), (IL-IIb), (IL-IIc), (IL-IId), (IL-IIe), (IL-IIf), (IL-IIg), (IL-III), (IL-IIIa1), (IL-IIIa2), (IL-IIIa3), (IL-IIIa4), (IL-IIIa5), (IL-IIIa6), (IL-IIIa7), or (IL-IIIa8), a phospholipid (such as an unsaturated lipid, *e.g.*, DOPE or DSPC), and a structural lipid. The elements of the lipid component may be provided in specific fractions.

[00213] In some embodiments, the lipid component of a LNP includes a lipid according to Formula (IL-I), (IL-IA), (IL-IB), (IL-II), (IL-IIa), (IL-IIb), (IL-IIc), (IL-IId), (IL-IIe), (IL-IIf), (IL-IIg), (IL-III), (IL-IIIa1), (IL-IIIa2), (IL-IIIa3), (IL-IIIa4), (IL-IIIa5), (IL-IIIa6), (IL-IIIa7), or (IL-IIIa8), a phospholipid, a PEG lipid, and a structural lipid. In some embodiments, the lipid component of the lipid nanoparticle includes about 30 mol % to about 60 mol % compound of Formula (IL-I), (IL-IA), (IL-IB), (IL-II), (IL-IIa), (IL-IIb), (IL-IIc), (IL-IId), (IL-IIe), (IL-IIf), (IL-IIg), (IL-III), (IL-IIIa1), (IL-IIIa2), (IL-IIIa3), (IL-IIIa4), (IL-IIIa5), (IL-IIIa6), (IL-IIIa7), or (IL-IIIa8), about 0 mol % to about 30 mol % phospholipid, about 18.5 mol % to about 48.5 mol % structural lipid, and about 0 mol % to about 10 mol % of PEG lipid, provided that the total mol % does not exceed 100%. In some embodiments, the lipid component of the lipid nanoparticle includes about 35 mol % to about 55 mol % compound of Formula (IL-I), (IL-IA), (IL-IB), (IL-II), (IL-IIa), (IL-IIb), (IL-IIc), (IL-IId), (IL-IIe), (IL-IIf), (IL-IIg), (IL-III), (IL-IIIa1), (IL-IIIa2), (IL-IIIa3), (IL-IIIa4), (IL-IIIa5), (IL-IIIa6), (IL-IIIa7), or (IL-IIIa8), about 5 mol % to about 25 mol % phospholipid, about 30 mol % to about 40 mol % structural lipid, and about 0 mol % to about 10 mol % of PEG lipid. In a particular embodiment, the lipid component includes about 50 mol % said compound, about 10 mol % phospholipid, about 38.5 mol % structural lipid, and about 1.5 mol % of PEG lipid. In another particular embodiment, the lipid component includes about 40 mol % said compound, about 20 mol % phospholipid, about 38.5 mol % structural lipid, and about 1.5 mol % of PEG lipid. In some embodiments, the phospholipid may be DOPE or DSPC. In some embodiments, the PEG lipid may be PEG-DMG and/or the structural lipid may be cholesterol.

[00214] Lipid nanoparticles may be designed for one or more specific applications or targets. In some embodiments, a LNP may be designed to deliver a therapeutic and/or prophylactic such as an RNA to a particular cell, tissue, organ, or system or group thereof in a mammal's body.

Physiochemical properties of lipid nanoparticles may be altered in order to increase selectivity for particular bodily targets. For instance, particle sizes may be adjusted based on the fenestration sizes of different organs. The therapeutic and/or prophylactic included in a LNP may also be selected based on the desired delivery target or targets. In some embodiments, a therapeutic and/or prophylactic may be selected for a particular indication, condition, disease, or disorder and/or for delivery to a particular cell, tissue, organ, or system or group thereof (e.g., localized or specific delivery). In some embodiments, a LNP may include an mRNA encoding a polypeptide of interest capable of being translated within a cell to produce the polypeptide of interest. Such a composition may be designed to be specifically delivered to a particular organ. In some embodiments, a composition may be designed to be specifically delivered to a mammalian liver.

[00215] The amount of a therapeutic and/or prophylactic in a LNP may depend on the size, composition, desired target and/or application, or other properties of the lipid nanoparticle as well as on the properties of the therapeutic and/or prophylactic. In some embodiments, the amount of an RNA useful in a LNP may depend on the size, sequence, and other characteristics of the RNA. The relative amounts of a therapeutic and/or prophylactic and other elements (e.g., lipids) in a LNP may also vary. In some embodiments, the wt/wt ratio of the lipid component to a therapeutic and/or prophylactic, such as a nucleic acid, in a LNP may be from about 5:1 to about 60:1, such as 5:1, 6:1, 7:1, 8:1, 9:1, 10:1, 11:1, 12:1, 13:1, 14:1, 15:1, 16:1, 17:1, 18:1, 19:1, 20:1, 25:1, 30:1, 35:1, 40:1, 45:1, 50:1, and 60:1. In some embodiments, the wt/wt ratio of the lipid component to a therapeutic and/or prophylactic may be from about 10:1 to about 40:1. In some embodiments, the wt/wt ratio is about 20:1. The amount of a therapeutic and/or prophylactic in a LNP may, for example, be measured using absorption spectroscopy (e.g., ultraviolet-visible spectroscopy).

[00216] In some embodiments, a LNP includes one or more RNAs, and the one or more RNAs, lipids, and amounts thereof may be selected to provide a specific N:P ratio. The N:P ratio of the composition refers to the molar ratio of nitrogen atoms in one or more lipids to the number of phosphate groups in an RNA. In general, a lower N:P ratio is preferred. The one or more RNA, lipids and amounts thereof may be selected to provide an N:P ratio from about 2:1 to about 30:1, such as 2:1, 3:1, 4:1, 5:1, 6:1, 7:1, 8:1, 9:1, 10:1, 12:1, 14:1, 16:1, 18:1, 20:1, 22:1, 24:1, 26:1, 28:1, or 30:1. In some embodiments, the N:P ratio may be from about 2:1 to about 8:1. In

some embodiments, the N:P ratio is from about 5:1 to about 8:1. In some embodiments, the N:P ratio may be about 5.0:1, about 5.5:1, about 5.67:1, about 6.0:1, about 6.5:1, or about 7.0:1. In some embodiments, the N:P ratio may be about 5.67:1.

[00217] In some embodiments, the formulation including a LNP may further include a salt, such as a chloride salt.

[00218] In some embodiments, the formulation including a LNP may further include a sugar such as a disaccharide. In some embodiments, the formulation further includes a sugar but not a salt, such as a chloride salt.

Physical Properties

[00219] The physical properties of the LNP of the present disclosure may be characterized by a variety of methods. In some embodiments, microscopy (*e.g.*, transmission electron microscopy or scanning electron microscopy) may be used to examine the morphology and size distribution of a LNP. Dynamic light scattering or potentiometry (*e.g.*, potentiometric titrations) may be used to measure zeta potentials. Dynamic light scattering may also be utilized to determine particle sizes. Instruments such as the Zetasizer Nano ZS (Malvern Instruments Ltd, Malvern, Worcestershire, UK) may also be used to measure multiple characteristics of a LNP, such as particle size, polydispersity index, and zeta potential.

[00220] The average LNP diameter of the LNP formulation may be between 10s of nm and 100s of nm, *e.g.*, measured by dynamic light scattering (DLS). In some embodiments, the average LNP diameter of the LNP formulation may be from about 40 nm to about 150 nm, such as about 40 nm, 45 nm, 50 nm, 55 nm, 60 nm, 65 nm, 70 nm, 75 nm, 80 nm, 85 nm, 90 nm, 95 nm, 100 nm, 105 nm, 110 nm, 115 nm, 120 nm, 125 nm, 130 nm, 135 nm, 140 nm, 145 nm, or 150 nm. In some embodiments, the average LNP diameter of the LNP formulation may be from about 50 nm to about 100 nm, from about 50 nm to about 90 nm, from about 50 nm to about 80 nm, from about 50 nm to about 70 nm, from about 50 nm to about 60 nm, from about 60 nm to about 100 nm, from about 60 nm to about 90 nm, from about 60 nm to about 80 nm, from about 60 nm to about 70 nm, from about 70 nm to about 100 nm, from about 70 nm to about 90 nm, from about 70 nm to about 80 nm, from about 80 nm to about 100 nm, from about 80 nm to about 90 nm, or from about 90 nm to about 100 nm. In some embodiments, the average LNP diameter of the LNP formulation may be from about 70 nm to about 100 nm. In a particular

embodiment, the average LNP diameter of the LNP formulation may be about 80 nm. In some embodiments, the average LNP diameter of the LNP formulation may be about 100 nm.

[00221] In some embodiments, the average LNP diameter of the LNP formulation ranges from about 1 mm to about 500 mm, from about 5 mm to about 200 mm, from about 10 mm to about 100 mm, from about 20 mm to about 80 mm, from about 25 mm to about 60 mm, from about 30 mm to about 55 mm, from about 35 mm to about 50 mm, or from about 38 mm to about 42 mm.

[00222] In some embodiments, the average LNP diameter of the LNP formulation is about 99% or less, about 98% or less, about 97% or less, about 96% or less, about 95% or less, about 90% or less, about 85% or less, about 80% or less, about 75% or less, about 70% or less, about 65% or less, about 60% or less, about 55% or less, about 50% or less, about 40% or less, about 30% or less, about 20% or less, or about 10% or less as compared to the LNP formulation produced by a comparable method.

[00223] A LNP may be relatively homogenous. A polydispersity index may be used to indicate the homogeneity of a LNP, *e.g.*, the particle size distribution of the lipid nanoparticles. A small (*e.g.*, less than 0.3) polydispersity index generally indicates a narrow particle size distribution. A LNP may have a polydispersity index from about 0 to about 0.25, such as 0.01, 0.02, 0.03, 0.04, 0.05, 0.06, 0.07, 0.08, 0.09, 0.10, 0.11, 0.12, 0.13, 0.14, 0.15, 0.16, 0.17, 0.18, 0.19, 0.20, 0.21, 0.22, 0.23, 0.24, or 0.25. In some embodiments, the polydispersity index of a LNP may be from about 0.10 to about 0.20.

[00224] The zeta potential of a LNP may be used to indicate the electrokinetic potential of the composition. In some embodiments, the zeta potential may describe the surface charge of a LNP. Lipid nanoparticles with relatively low charges, positive or negative, are generally desirable, as more highly charged species may interact undesirably with cells, tissues, and other elements in the body. In some embodiments, the zeta potential of a LNP may be from about -10 mV to about +20 mV, from about -10 mV to about +15 mV, from about -10 mV to about +10 mV, from about -10 mV to about +5 mV, from about -10 mV to about 0 mV, from about -10 mV to about -5 mV, from about -5 mV to about +20 mV, from about -5 mV to about +15 mV, from about -5 mV to about +10 mV, from about -5 mV to about +5 mV, from about -5 mV to about 0 mV, from about 0 mV to about +20 mV, from about 0 mV to about +15 mV, from about 0 mV to

about +10 mV, from about 0 mV to about +5 mV, from about +5 mV to about +20 mV, from about +5 mV to about +15 mV, or from about +5 mV to about +10 mV.

[00225] The efficiency of encapsulation of a therapeutic and/or prophylactic, such as a nucleic acid describes the amount of therapeutic and/or prophylactic that is encapsulated or otherwise associated with a LNP after preparation, relative to the initial amount provided. The encapsulation efficiency is desirably high (*e.g.*, close to 100%). The encapsulation efficiency may be measured, for example, by comparing the amount of therapeutic and/or prophylactic in a solution containing the lipid nanoparticle before and after breaking up the lipid nanoparticle with one or more organic solvents or detergents. An anion exchange resin may be used to measure the amount of free therapeutic and/or prophylactic (*e.g.*, RNA) in a solution. Fluorescence may be used to measure the amount of free therapeutic and/or prophylactic (*e.g.*, RNA) in a solution. For the lipid nanoparticles described herein, the encapsulation efficiency of a therapeutic and/or prophylactic may be at least 50%, for example 50%, 55%, 60%, 65%, 70%, 75%, 80%, 85%, 90%, 91%, 92%, 93%, 94%, 95%, 96%, 97%, 98%, 99%, or 100%. In some embodiments, the encapsulation efficiency may be at least 80%. In some embodiments, the encapsulation efficiency may be at least 90%. In some embodiments, the encapsulation efficiency may be at least 95%.

[00226] A LNP may optionally comprise one or more coatings. In some embodiments, a LNP may be formulated in a capsule, film, or tablet having a coating. A capsule, film, or tablet including a composition described herein may have any useful size, tensile strength, hardness or density.

Chemical Properties

[00227] The chemical properties of the LNP, LNP solution, lyophilized LNP composition, or LNP formulation of the present disclosure may be characterized by a variety of methods. In some embodiments, electrophoresis (*e.g.*, capillary electrophoresis) or chromatography (*e.g.*, reverse phase liquid chromatography) may be used to examine the mRNA integrity.

[00228] In some embodiments, the LNP integrity of the LNP, LNP solution, lyophilized LNP composition, or LNP formulation of the present disclosure is about 20% or higher, about 25% or higher, about 30% or higher, about 35% or higher, about 40% or higher, about 45% or higher, about 50% or higher, about 55% or higher, about 60% or higher, about 65% or higher, about

70% or higher, about 75% or higher, about 80% or higher, about 85% or higher, about 90% or higher, about 95% or higher, about 96% or higher, about 97% or higher, about 98% or higher, or about 99% or higher.

[00229] In some embodiments, the LNP integrity of the LNP, LNP solution, lyophilized LNP composition, or LNP formulation of the present disclosure is higher than the LNP integrity of the LNP, LNP solution, lyophilized LNP composition, or LNP formulation produced by a comparable method by about 5% or higher, about 10% or more, about 15% or more, about 20% or more, about 30% or more, about 40% or more, about 50% or more, about 60% or more, about 70% or more, about 80% or more, about 90% or more, about 1 folds or more, about 2 folds or more, about 3 folds or more, about 4 folds or more, about 5 folds or more, about 10 folds or more, about 20 folds or more, about 30 folds or more, about 40 folds or more, about 50 folds or more, about 100 folds or more, about 200 folds or more, about 300 folds or more, about 400 folds or more, about 500 folds or more, about 1000 folds or more, about 2000 folds or more, about 3000 folds or more, about 4000 folds or more, about 5000 folds or more, or about 10000 folds or more.

[00230] In some embodiments, the $T_{80\%}$ of the LNP, LNP solution, lyophilized LNP composition, or LNP formulation of the present disclosure is about 12 months or longer, about 15 months or longer, about 18 months or longer, about 21 months or longer, about 24 months or longer, about 27 months or longer, about 30 months or longer, about 33 months or longer, about 36 months or longer, about 48 months or longer, about 60 months or longer, about 72 months or longer, about 84 months or longer, about 96 months or longer, about 108 months or longer, about 120 months or longer.

[00231] In some embodiments, the $T_{80\%}$ of the LNP, LNP solution, lyophilized LNP composition, or LNP formulation of the present disclosure is longer than the $T_{80\%}$ of the LNP, LNP solution, lyophilized LNP composition, or LNP formulation produced by a comparable method by about 5% or higher, about 10% or more, about 15% or more, about 20% or more, about 30% or more, about 40% or more, about 50% or more, about 60% or more, about 70% or more, about 80% or more, about 90% or more, about 1 folds or more, about 2 folds or more, about 3 folds or more, about 4 folds or more, about 5 folds or more.

[00232] In some embodiments, the $T_{1/2}$ of the LNP, LNP solution, lyophilized LNP composition, or LNP formulation of the present disclosure is about 12 months or longer, about

15 months or longer, about 18 months or longer, about 21 months or longer, about 24 months or longer, about 27 months or longer, about 30 months or longer, about 33 months or longer, about 36 months or longer, about 48 months or longer, about 60 months or longer, about 72 months or longer, about 84 months or longer, about 96 months or longer, about 108 months or longer, about 120 months or longer.

[00233] In some embodiments, the $T_{1/2}$ of the LNP, LNP solution, lyophilized LNP composition, or LNP formulation of the present disclosure is longer than the $T_{1/2}$ of the LNP, LNP solution, lyophilized LNP composition, or LNP formulation produced by a comparable method by about 5% or higher, about 10% or more, about 15% or more, about 20% or more, about 30% or more, about 40% or more, about 50% or more, about 60% or more, about 70% or more, about 80% or more, about 90% or more, about 1 folds or more, about 2 folds or more, about 3 folds or more, about 4 folds or more, about 5 folds or more

Definitions

[00234] As used herein, the term “alkyl” or “alkyl group” means a linear or branched, saturated hydrocarbon including one or more carbon atoms (*e.g.*, one, two, three, four, five, six, seven, eight, nine, ten, eleven, twelve, thirteen, fourteen, fifteen, sixteen, seventeen, eighteen, nineteen, twenty, or more carbon atoms), which is optionally substituted. The notation “C₁₋₁₄ alkyl” means an optionally substituted linear or branched, saturated hydrocarbon including 1-14 carbon atoms. Unless otherwise specified, an alkyl group described herein refers to both unsubstituted and substituted alkyl groups.

[00235] As used herein, the term “alkenyl” or “alkenyl group” means a linear or branched hydrocarbon including two or more carbon atoms (*e.g.*, two, three, four, five, six, seven, eight, nine, ten, eleven, twelve, thirteen, fourteen, fifteen, sixteen, seventeen, eighteen, nineteen, twenty, or more carbon atoms) and at least one double bond, which is optionally substituted. The notation “C₂₋₁₄ alkenyl” means an optionally substituted linear or branched hydrocarbon including 2-14 carbon atoms and at least one carbon-carbon double bond. An alkenyl group may include one, two, three, four, or more carbon-carbon double bonds. In some embodiments, C₁₈ alkenyl may include one or more double bonds. A C₁₈ alkenyl group including two double bonds may be a linoleyl group. Unless otherwise specified, an alkenyl group described herein refers to both unsubstituted and substituted alkenyl groups.

[00236] As used herein, the term “carbocycle” or “carbocyclic group” means an optionally substituted mono- or multi-cyclic system including one or more rings of carbon atoms. Rings may be three, four, five, six, seven, eight, nine, ten, eleven, twelve, thirteen, fourteen, fifteen, sixteen, seventeen, eighteen, nineteen, or twenty membered rings. The notation “C₃₋₆ carbocycle” means a carbocycle including a single ring having 3-6 carbon atoms. Carbocycles may include one or more carbon-carbon double or triple bonds and may be non-aromatic or aromatic (*e.g.*, cycloalkyl or aryl groups). Examples of carbocycles include cyclopropyl, cyclopentyl, cyclohexyl, phenyl, naphthyl, and 1,2-dihydronaphthyl groups. The term “cycloalkyl” as used herein means a non-aromatic carbocycle and may or may not include any double or triple bond. Unless otherwise specified, carbocycles described herein refers to both unsubstituted and substituted carbocycle groups, *i.e.*, optionally substituted carbocycles.

[00237] As used herein, the term “heterocycle” or “heterocyclic group” means an optionally substituted mono- or multi-cyclic system including one or more rings, where at least one ring includes at least one heteroatom. Heteroatoms may be, for example, nitrogen, oxygen, or sulfur atoms. Rings may be three, four, five, six, seven, eight, nine, ten, eleven, twelve, thirteen, or fourteen membered rings. Heterocycles may include one or more double or triple bonds and may be non-aromatic or aromatic (*e.g.*, heterocycloalkyl or heteroaryl groups). Examples of heterocycles include imidazolyl, imidazolidinyl, oxazolyl, oxazolidinyl, thiazolyl, thiazolidinyl, pyrazolidinyl, pyrazolyl, isoxazolidinyl, isoxazolyl, isothiazolidinyl, isothiazolyl, morpholinyl, pyrrolyl, pyrrolidinyl, furyl, tetrahydrofuryl, thiophenyl, pyridinyl, piperidinyl, quinolyl, and isoquinolyl groups. The term “heterocycloalkyl” as used herein means a non-aromatic heterocycle and may or may not include any double or triple bond. Unless otherwise specified, heterocycles described herein refers to both unsubstituted and substituted heterocycle groups, *i.e.*, optionally substituted heterocycles.

[00238] As used herein, a “biodegradable group” is a group that may facilitate faster metabolism of a lipid in a mammalian entity. A biodegradable group may be selected from the group consisting of, but is not limited to, -C(O)O-, -OC(O)-, -C(O)N(R')-, -N(R')C(O)-, -C(O)-,

[00239] -C(S)-, -C(S)S-, -SC(S)-, -CH(OH)-, -P(O)(OR')O-, -S(O)₂-, an aryl group, and a heteroaryl group. As used herein, an “aryl group” is an optionally substituted carbocyclic group including one or more aromatic rings. Examples of aryl groups include phenyl and naphthyl groups. As used herein, a “heteroaryl group” is an optionally substituted heterocyclic group

including one or more aromatic rings. Examples of heteroaryl groups include pyrrolyl, furyl, thiophenyl, imidazolyl, oxazolyl, and thiazolyl. Both aryl and heteroaryl groups may be optionally substituted. In some embodiments, M and M' can be selected from the non-limiting group consisting of optionally substituted phenyl, oxazole, and thiazole. In the formulas herein, M and M' can be independently selected from the list of biodegradable groups above. Unless otherwise specified, aryl or heteroaryl groups described herein refers to both unsubstituted and substituted groups, i.e., optionally substituted aryl or heteroaryl groups.

[00240] Alkyl, alkenyl, and cyclyl (*e.g.*, carbocyclyl and heterocyclyl) groups may be optionally substituted unless otherwise specified. Optional substituents may be selected from the group consisting of, but are not limited to, a halogen atom (*e.g.*, a chloride, bromide, fluoride, or iodide group), a carboxylic acid (*e.g.*, -C(O)OH), an alcohol (*e.g.*, a hydroxyl, -OH), an ester (*e.g.*, -C(O)OR or -OC(O)R), an aldehyde (*e.g.*, -C(O)H), a carbonyl (*e.g.*, -C(O)R, alternatively represented by C=O), an acyl halide (*e.g.*, -C(O)X, in which X is a halide selected from bromide, fluoride, chloride, and iodide), a carbonate (*e.g.*, -OC(O)OR), an alkoxy (*e.g.*, -OR), an acetal (*e.g.*, -C(OR)₂R'''), in which each OR are alkoxy groups that can be the same or different and R''' is an alkyl or alkenyl group), a phosphate (*e.g.*, P(O)₄³⁻), a thiol (*e.g.*, -SH), a sulfoxide (*e.g.*, -S(O)R), a sulfinic acid (*e.g.*, -S(O)OH), a sulfonic acid (*e.g.*, -S(O)₂OH), a thial (*e.g.*, -C(S)H), a sulfate (*e.g.*, S(O)₄²⁻), a sulfonyl (*e.g.*, -S(O)₂-), an amide (*e.g.*, -C(O)NR₂, or -N(R)C(O)R), an azido (*e.g.*, -N₃), a nitro (*e.g.*, -NO₂), a cyano (*e.g.*, -CN), an isocyano (*e.g.*, -NC), an acyloxy (*e.g.*, -OC(O)R), an amino (*e.g.*, -NR₂, -NRH, or -NH₂), a carbamoyl (*e.g.*, -OC(O)NR₂, -OC(O)NRH, or -OC(O)NH₂), a sulfonamide (*e.g.*, -S(O)₂NR₂, -S(O)₂NRH, -S(O)₂NH₂, -N(R)S(O)₂R, -N(H)S(O)₂R, -N(R)S(O)₂H, or -N(H)S(O)₂H), an alkyl group, an alkenyl group, and a cyclyl (*e.g.*, carbocyclyl or heterocyclyl) group. In any of the preceding, R is an alkyl or alkenyl group, as defined herein. In some embodiments, the substituent groups themselves may be further substituted with, for example, one, two, three, four, five, or six substituents as defined herein. In some embodiments, a C₁₋₆ alkyl group may be further substituted with one, two, three, four, five, or six substituents as described herein.

[00241] About, Approximately: As used herein, the terms “approximately” and “about,” as applied to one or more values of interest, refer to a value that is similar to a stated reference value. In some embodiments, the term “approximately” or “about” refers to a range of values that fall within 25%, 20%, 19%, 18%, 17%, 16%, 15%, 14%, 13%, 12%, 11%, 10%, 9%, 8%,

7%, 6%, 5%, 4%, 3%, 2%, 1%, or less in either direction (greater than or less than) of the stated reference value unless otherwise stated or otherwise evident from the context (except where such number would exceed 100% of a possible value). In some embodiments, when used in the context of an amount of a given compound in a lipid component of a LNP, “about” may mean +/- 10% of the recited value. For instance, a LNP including a lipid component having about 40% of a given compound may include 30-50% of the compound.

[00242] As used herein, the term “compound,” is meant to include all isomers and isotopes of the structure depicted. “Isotopes” refers to atoms having the same atomic number but different mass numbers resulting from a different number of neutrons in the nuclei. In some embodiments, isotopes of hydrogen include tritium and deuterium. Further, a compound, salt, or complex of the present disclosure can be prepared in combination with solvent or water molecules to form solvates and hydrates by routine methods.

[00243] As used herein, the term “contacting” means establishing a physical connection between two or more entities. In some embodiments, contacting a mammalian cell with a LNP means that the mammalian cell and a nanoparticle are made to share a physical connection. Methods of contacting cells with external entities both in vivo and ex vivo are well known in the biological arts. In some embodiments, contacting a LNP and a mammalian cell disposed within a mammal may be performed by varied routes of administration (*e.g.*, intravenous, intramuscular, intradermal, and subcutaneous) and may involve varied amounts of lipid nanoparticles. Moreover, more than one mammalian cell may be contacted by a LNP.

[00244] As used herein, the term “comparable method” refers to a method with comparable parameters or steps, as of the method being compared (*e.g.*, the producing the LNP formulation of the present disclosure). In some embodiments, the “comparable method” is a method with one or more of steps i), ia), iaa), ib), ii), iia), iib), iic), iid), and iie) of the method being compared. In some embodiments, the “comparable method” is a method without one or more of steps i), ia), iaa), ib), ii), iia), iib), iic), iid), and iie) of the method being compared. In some embodiments, the “comparable method” is a method without one or more of steps ia) and ib) of the method being compared. In some embodiments, the “comparable method” is a method employing a water-soluble salt of a nucleic acid. In some embodiments, the “comparable method” is a method employing an organic solution that does not comprise an organic solvent-

soluble nucleic acid. In some embodiments, the “comparable method” is a method comprising processing the lipid nanoparticle prior to administering the lipid nanoparticle formulation.

[00245] As used herein, the term “delivering” means providing an entity to a destination. In some embodiments, delivering a therapeutic and/or prophylactic to a subject may involve administering a LNP including the therapeutic and/or prophylactic to the subject (*e.g.*, by an intravenous, intramuscular, intradermal, or subcutaneous route). Administration of a LNP to a mammal or mammalian cell may involve contacting one or more cells with the lipid nanoparticle.

[00246] As used herein, the term “enhanced delivery” means delivery of more (*e.g.*, at least 1.5 fold more, at least 2-fold more, at least 3-fold more, at least 4-fold more, at least 5-fold more, at least 6-fold more, at least 7-fold more, at least 8-fold more, at least 9-fold more, at least 10-fold more) of a therapeutic and/or prophylactic by a nanoparticle to a target tissue of interest (*e.g.*, mammalian liver) compared to the level of delivery of a therapeutic and/or prophylactic by a control nanoparticle to a target tissue of interest (*e.g.*, MC3, KC2, or DLinDMA). The level of delivery of a nanoparticle to a particular tissue may be measured by comparing the amount of protein produced in a tissue to the weight of said tissue, comparing the amount of therapeutic and/or prophylactic in a tissue to the weight of said tissue, comparing the amount of protein produced in a tissue to the amount of total protein in said tissue, or comparing the amount of therapeutic and/or prophylactic in a tissue to the amount of total therapeutic and/or prophylactic in said tissue. It will be understood that the enhanced delivery of a nanoparticle to a target tissue need not be determined in a subject being treated, it may be determined in a surrogate such as an animal model (*e.g.*, a rat model).

[00247] As used herein, the term “specific delivery,” “specifically deliver,” or “specifically delivering” means delivery of more (*e.g.*, at least 1.5 fold more, at least 2-fold more, at least 3-fold more, at least 4-fold more, at least 5-fold more, at least 6-fold more, at least 7-fold more, at least 8-fold more, at least 9-fold more, at least 10-fold more) of a therapeutic and/or prophylactic by a nanoparticle to a target tissue of interest (*e.g.*, mammalian liver) compared to an off-target tissue (*e.g.*, mammalian spleen). The level of delivery of a nanoparticle to a particular tissue may be measured by comparing the amount of protein produced in a tissue to the weight of said tissue, comparing the amount of therapeutic and/or prophylactic in a tissue to the weight of said tissue, comparing the amount of protein produced in a tissue to the amount of total protein in said

tissue, or comparing the amount of therapeutic and/or prophylactic in a tissue to the amount of total therapeutic and/or prophylactic in said tissue. In some embodiments, for renovascular targeting, a therapeutic and/or prophylactic is specifically provided to a mammalian kidney as compared to the liver and spleen if 1.5, 2-fold, 3-fold, 5-fold, 10-fold, 15 fold, or 20 fold more therapeutic and/or prophylactic per 1 g of tissue is delivered to a kidney compared to that delivered to the liver or spleen following systemic administration of the therapeutic and/or prophylactic. It will be understood that the ability of a nanoparticle to specifically deliver to a target tissue need not be determined in a subject being treated, it may be determined in a surrogate such as an animal model (*e.g.*, a rat model).

[00248] As used herein, “encapsulation efficiency” refers to the amount of a therapeutic and/or prophylactic that becomes part of a LNP, relative to the initial total amount of therapeutic and/or prophylactic used in the preparation of a LNP. In some embodiments, if 97 mg of therapeutic and/or prophylactic are encapsulated in a LNP out of a total 100 mg of therapeutic and/or prophylactic initially provided to the composition, the encapsulation efficiency may be given as 97%. As used herein, “encapsulation” may refer to complete, substantial, or partial enclosure, confinement, surrounding, or encasement.

[00249] As used herein, “expression” of a nucleic acid sequence refers to translation of an mRNA into a polypeptide or protein and/or post-translational modification of a polypeptide or protein.

[00250] As used herein, the term “in vitro” refers to events that occur in an artificial environment, *e.g.*, in a test tube or reaction vessel, in cell culture, in a Petri dish, etc., rather than within an organism (*e.g.*, animal, plant, or microbe).

[00251] As used herein, the term “in vivo” refers to events that occur within an organism (*e.g.*, animal, plant, or microbe or cell or tissue thereof).

[00252] As used herein, the term “ex vivo” refers to events that occur outside of an organism (*e.g.*, animal, plant, or microbe or cell or tissue thereof). Ex vivo events may take place in an environment minimally altered from a natural (*e.g.*, in vivo) environment.

[00253] As used herein, the term “isomer” means any geometric isomer, tautomer, zwitterion, stereoisomer, enantiomer, or diastereomer of a compound. Compounds may include one or more chiral centers and/or double bonds and may thus exist as stereoisomers, such as double-bond isomers (*i.e.*, geometric E/Z isomers) or diastereomers (*e.g.*, enantiomers (*i.e.*, (+) or (-)) or

cis/trans isomers). The present disclosure encompasses any and all isomers of the compounds described herein, including stereomerically pure forms (*e.g.*, geometrically pure, enantiomerically pure, or diastereomerically pure) and enantiomeric and stereoisomeric mixtures, *e.g.*, racemates. Enantiomeric and stereomeric mixtures of compounds and means of resolving them into their component enantiomers or stereoisomers are well-known.

[00254] As used herein, a “lipid component” is that component of a lipid nanoparticle that includes one or more lipids. In some embodiments, the lipid component may include one or more cationic/ionizable, PEGylated, structural, or other lipids, such as phospholipids.

[00255] As used herein, a “linker” is a moiety connecting two moieties, for example, the connection between two nucleosides of a cap species. A linker may include one or more groups including but not limited to phosphate groups (*e.g.*, phosphates, boranophosphates, thiophosphates, selenophosphates, and phosphonates), alkyl groups, amidates, or glycerols. In some embodiments, two nucleosides of a cap analog may be linked at their 5' positions by a triphosphate group or by a chain including two phosphate moieties and a boranophosphate moiety.

[00256] As used herein, “methods of administration” may include intravenous, intramuscular, intradermal, subcutaneous, or other methods of delivering a composition to a subject. A method of administration may be selected to target delivery (*e.g.*, to specifically deliver) to a specific region or system of a body.

[00257] As used herein, “modified” means non-natural. In some embodiments, an RNA may be a modified RNA. That is, an RNA may include one or more nucleobases, nucleosides, nucleotides, or linkers that are non-naturally occurring. A “modified” species may also be referred to herein as an “altered” species. Species may be modified or altered chemically, structurally, or functionally. In some embodiments, a modified nucleobase species may include one or more substitutions that are not naturally occurring.

[00258] As used herein, the “N:P ratio” is the molar ratio of ionizable (in the physiological pH range) nitrogen atoms in a lipid to phosphate groups in an RNA, *e.g.*, in a LNP including a lipid component and an RNA.

[00259] As used herein, a “lipid nanoparticle” is a composition comprising one or more lipids. Lipid nanoparticles are typically sized on the order of micrometers or smaller and may include a lipid bilayer. Lipid nanoparticles, as used herein, unless otherwise specified, encompass lipid

nanoparticles (LNPs), liposomes (*e.g.*, lipid vesicles), and lipoplexes. In some embodiments, a LNP may be a liposome having a lipid bilayer with a diameter of 500 nm or less.

[00260] As used herein, “naturally occurring” means existing in nature without artificial aid.

[00261] As used herein, “patient” refers to a subject who may seek or be in need of treatment, requires treatment, is receiving treatment, will receive treatment, or a subject who is under care by a trained professional for a particular disease or condition.

[00262] As used herein, a “PEG lipid” or “PEGylated lipid” refers to a lipid comprising a polyethylene glycol component.

[00263] The phrase “pharmaceutically acceptable” is used herein to refer to those compounds, materials, composition, and/or dosage forms which are, within the scope of sound medical judgment, suitable for use in contact with the tissues of human beings and animals without excessive toxicity, irritation, allergic response, or other problems or complication, commensurate with a reasonable benefit/risk ratio.

[00264] The phrase “pharmaceutically acceptable excipient,” as used herein, refers to any ingredient other than the compounds described herein (for example, a vehicle capable of suspending, complexing, or dissolving the active compound) and having the properties of being substantially nontoxic and non-inflammatory in a patient. Excipients may include, for example: anti-adherents, antioxidants, binders, coatings, compression aids, disintegrants, dyes (colors), emollients, emulsifiers, fillers (diluent), film formers or coatings, flavors, fragrances, glidants (flow enhancers), lubricants, preservatives, printing inks, sorbents, suspending or dispersing agents, sweeteners, and waters of hydration. Exemplary excipients include, but are not limited to: butylated hydroxytoluene (BHT), calcium carbonate, calcium phosphate (dibasic), calcium stearate, croscarmellose, crosslinked polyvinyl pyrrolidone, citric acid, crospovidone, cysteine, ethylcellulose, gelatin, hydroxypropyl cellulose, hydroxypropyl methylcellulose, lactose, magnesium stearate, maltitol, mannitol, methionine, methylcellulose, methyl paraben, microcrystalline cellulose, polyethylene glycol, polyvinyl pyrrolidone, povidone, pregelatinized starch, propyl paraben, retinyl palmitate, shellac, silicon dioxide, sodium carboxymethyl cellulose, sodium citrate, sodium starch glycolate, sorbitol, starch (corn), stearic acid, sucrose, talc, titanium dioxide, vitamin A, vitamin E (alpha-tocopherol), vitamin C, xylitol, and other species disclosed herein.

[00265] Compositions may also include salts of one or more compounds. Salts may be pharmaceutically acceptable salts. As used herein, “pharmaceutically acceptable salts” refers to derivatives of the disclosed compounds wherein the parent compound is altered by converting an existing acid or base moiety to its salt form (*e.g.*, by reacting a free base group with a suitable organic acid). Examples of pharmaceutically acceptable salts include, but are not limited to, mineral or organic acid salts of basic residues such as amines; alkali or organic salts of acidic residues such as carboxylic acids; and the like. Representative acid addition salts include acetate, adipate, alginate, ascorbate, aspartate, benzenesulfonate, benzoate, bisulfate, borate, butyrate, camphorate, camphorsulfonate, citrate, cyclopentanepropionate, digluconate, dodecylsulfate, ethanesulfonate, fumarate, glucoheptonate, glycerophosphate, hemisulfate, heptonate, hexanoate, hydrobromide, hydrochloride, hydroiodide, 2-hydroxy-ethanesulfonate, lactobionate, lactate, laurate, lauryl sulfate, malate, maleate, malonate, methanesulfonate, 2-naphthalenesulfonate, nicotinate, nitrate, oleate, oxalate, palmitate, pamoate, pectinate, persulfate, 3-phenylpropionate, phosphate, picrate, pivalate, propionate, stearate, succinate, sulfate, tartrate, thiocyanate, toluenesulfonate, undecanoate, valerate salts, and the like. Representative alkali or alkaline earth metal salts include sodium, lithium, potassium, calcium, magnesium, and the like, as well as nontoxic ammonium, quaternary ammonium, and amine cations, including, but not limited to ammonium, tetramethylammonium, tetraethylammonium, methylamine, dimethylamine, trimethylamine, triethylamine, ethylamine, and the like. The pharmaceutically acceptable salts of the present disclosure include the conventional non-toxic salts of the parent compound formed, for example, from non-toxic inorganic or organic acids. The pharmaceutically acceptable salts of the present disclosure can be synthesized from the parent compound which contains a basic or acidic moiety by conventional chemical methods. Generally, such salts can be prepared by reacting the free acid or base forms of these compounds with a stoichiometric amount of the appropriate base or acid in water or in an organic solvent, or in a mixture of the two; generally, nonaqueous media like ether, ethyl acetate, ethanol, isopropanol, or acetonitrile are preferred. Lists of suitable salts are found in Remington’s Pharmaceutical Sciences, 17th ed., Mack Publishing Company, Easton, Pa., 1985, p. 1418, Pharmaceutical Salts: Properties, Selection, and Use, P.H. Stahl and C.G. Wermuth (eds.), Wiley-VCH, 2008, and Berge et al., Journal of Pharmaceutical Science, 66, 1-19 (1977), each of which is incorporated herein by reference in its entirety.

[00266] As used herein, a “phospholipid” is a lipid that includes a phosphate moiety and one or more carbon chains, such as unsaturated fatty acid chains. A phospholipid may include one or more multiple (*e.g.*, double or triple) bonds (*e.g.*, one or more saturations). A phospholipid or an analog or derivative thereof may include choline. A phospholipid or an analog or derivative thereof may not include choline. Particular phospholipids may facilitate fusion to a membrane. In some embodiments, a cationic phospholipid may interact with one or more negatively charged phospholipids of a membrane (*e.g.*, a cellular or intracellular membrane). Fusion of a phospholipid to a membrane may allow one or more elements of a lipid-containing composition to pass through the membrane permitting, *e.g.*, delivery of the one or more elements to a cell.

[00267] As used herein, the “polydispersity index” is a ratio that describes the homogeneity of the particle size distribution of a system. A small value, *e.g.*, less than 0.3, indicates a narrow particle size distribution.

[00268] As used herein, an amphiphilic “polymer” is an amphiphilic compound that comprises an oligomer or a polymer. In some embodiments, an amphiphilic polymer can comprise an oligomer fragment, such as two or more PEG monomer units. In some embodiments, an amphiphilic polymer described herein can be PS 20.

[00269] As used herein, the term “polypeptide” or “polypeptide of interest” refers to a polymer of amino acid residues typically joined by peptide bonds that can be produced naturally (*e.g.*, isolated or purified) or synthetically.

[00270] As used herein, an “RNA” refers to a ribonucleic acid that may be naturally or non-naturally occurring. In some embodiments, an RNA may include modified and/or non-naturally occurring components such as one or more nucleobases, nucleosides, nucleotides, or linkers. An RNA may include a cap structure, a chain terminating nucleoside, a stem loop, a polyA sequence, and/or a polyadenylation signal. An RNA may have a nucleotide sequence encoding a polypeptide of interest. In some embodiments, an RNA may be a messenger RNA (mRNA). Translation of an mRNA encoding a particular polypeptide, for example, *in vivo* translation of an mRNA inside a mammalian cell, may produce the encoded polypeptide. RNAs may be selected from the non-limiting group consisting of small interfering RNA (siRNA), asymmetrical interfering RNA (aiRNA), microRNA (miRNA), Dicer-substrate RNA (dsRNA), small hairpin RNA (shRNA), mRNA, long non-coding RNA (lncRNA) and mixtures thereof.

[00271] As used herein, a “single unit dose” is a dose of any therapeutic administered in one dose/at one time/single route/single point of contact, i.e., single administration event.

[00272] As used herein, a “split dose” is the division of a single unit dose or total daily dose into two or more doses.

[00273] As used herein, a “total daily dose” is an amount given or prescribed in a 24 hour period. It may be administered as a single unit dose.

[00274] As used herein, the term “subject” refers to any organism to which a composition or formulation in accordance with the disclosure may be administered, *e.g.*, for experimental, diagnostic, prophylactic, and/or therapeutic purposes. Typical subjects include animals (*e.g.*, mammals such as mice, rats, rabbits, non-human primates, and humans) and/or plants.

[00275] As used herein, “ T_x ” refers to the amount of time lasted for the nucleic acid integrity (*e.g.*, mRNA integrity) of a LNP, LNP solution, lyophilized LNP composition, or LNP formulation to degrade to about X of the initial integrity of the nucleic acid (*e.g.*, mRNA) used for the preparation of the LNP, LNP solution, lyophilized LNP composition, or LNP formulation. For example, “ $T_{80\%}$ ” refers to the amount of time lasted for the nucleic acid integrity (*e.g.*, mRNA integrity) of a LNP, LNP solution, lyophilized LNP composition, or LNP formulation to degrade to about 80% of the initial integrity of the nucleic acid (*e.g.*, mRNA) used for the preparation of the LNP, LNP solution, lyophilized LNP composition, or LNP formulation. For another example, “ $T_{1/2}$ ” refers to the amount of time lasted for the nucleic acid integrity (*e.g.*, mRNA integrity) of a LNP, LNP solution, lyophilized LNP composition, or LNP formulation to degrade to about 1/2 of the initial integrity of the nucleic acid (*e.g.*, mRNA) used for the preparation of the LNP, LNP solution, lyophilized LNP composition, or LNP formulation.

[00276] As used herein, “targeted cells” refers to any one or more cells of interest. The cells may be found *in vitro*, *in vivo*, *in situ*, or in the tissue or organ of an organism. The organism may be an animal, preferably a mammal, more preferably a human and most preferably a patient.

[00277] As used herein, “target tissue” refers to any one or more tissue types of interest in which the delivery of a therapeutic and/or prophylactic would result in a desired biological and/or pharmacological effect. Examples of target tissues of interest include specific tissues, organs, and systems or groups thereof. In particular applications, a target tissue may be a kidney, a lung, a spleen, vascular endothelium in vessels (*e.g.*, intra-coronary or intra-femoral), or tumor

tissue (*e.g.*, via intratumoral injection). An “off-target tissue” refers to any one or more tissue types in which the expression of the encoded protein does not result in a desired biological and/or pharmacological effect. In particular applications, off-target tissues may include the liver and the spleen.

[00278] The term “therapeutic agent” or “prophylactic agent” refers to any agent that, when administered to a subject, has a therapeutic, diagnostic, and/or prophylactic effect and/or elicits a desired biological and/or pharmacological effect. Therapeutic agents are also referred to as “actives” or “active agents.” Such agents include, but are not limited to, cytotoxins, radioactive ions, chemotherapeutic agents, small molecule drugs, proteins, and nucleic acids.

[00279] As used herein, the term “therapeutically effective amount” means an amount of an agent to be delivered (*e.g.*, nucleic acid, drug, composition, therapeutic agent, diagnostic agent, prophylactic agent, etc.) that is sufficient, when administered to a subject suffering from or susceptible to an infection, disease, disorder, and/or condition, to treat, improve symptoms of, diagnose, prevent, and/or delay the onset of the infection, disease, disorder, and/or condition.

[00280] As used herein, “transfection” refers to the introduction of a species (*e.g.*, an RNA) into a cell. Transfection may occur, for example, *in vitro*, *ex vivo*, or *in vivo*.

[00281] As used herein, the term “treating” refers to partially or completely alleviating, ameliorating, improving, relieving, delaying onset of, inhibiting progression of, reducing severity of, and/or reducing incidence of one or more symptoms or features of a particular infection, disease, disorder, and/or condition. In some embodiments, “treating” cancer may refer to inhibiting survival, growth, and/or spread of a tumor. Treatment may be administered to a subject who does not exhibit signs of a disease, disorder, and/or condition and/or to a subject who exhibits only early signs of a disease, disorder, and/or condition for the purpose of decreasing the risk of developing pathology associated with the disease, disorder, and/or condition.

[00282] As used herein, the “zeta potential” is the electrokinetic potential of a lipid, *e.g.*, in a particle composition.

Ionizable Lipids

[00283] In some aspects, the ionizable lipids of the present disclosure may be one or more of compounds of Formula (IL-1):

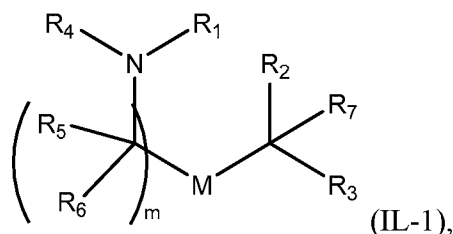

or their N-oxides, or salts or isomers thereof, wherein:

R₁ is selected from the group consisting of C₅₋₃₀ alkyl, C₅₋₂₀ alkenyl, -R*YR'', -YR'', and -R''M'R';

R₂ and R₃ are independently selected from the group consisting of H, C₁₋₁₄ alkyl, C₂₋₁₄ alkenyl, -R*YR'', -YR'', and -R*OR'', or R₂ and R₃, together with the atom to which they are attached, form a heterocycle or carbocycle;

R₄ is selected from the group consisting of hydrogen, a C₃₋₆ carbocycle, -(CH₂)_nQ, -(CH₂)_nCHQR, -CHQR, -CQ(R)₂, and unsubstituted C₁₋₆ alkyl, where Q is selected from a carbocycle, heterocycle, -OR, -O(CH₂)_nN(R)₂, -C(O)OR, -OC(O)R, -CX₃, -CX₂H, -CXH₂, -CN, -N(R)₂, -C(O)N(R)₂, -N(R)C(O)R, -N(R)S(O)₂R, -N(R)C(O)N(R)₂, -N(R)C(S)N(R)₂, -N(R)R₈, N(R)S(O)₂R₈, -O(CH₂)_nOR, -N(R)C(=NR₉)N(R)₂, -N(R)C(=CHR₉)N(R)₂, -OC(O)N(R)₂, -N(R)C(O)OR, -N(OR)C(O)R, -N(OR)S(O)₂R, -N(OR)C(O)OR, -N(OR)C(O)N(R)₂, -N(OR)C(S)N(R)₂, -N(OR)C(=NR₉)N(R)₂, -N(OR)C(=CHR₉)N(R)₂, -C(=NR₉)N(R)₂, -C(=NR₉)R, -C(O)N(R)OR, and -C(R)N(R)₂C(O)OR, and each n is independently selected from 1, 2, 3, 4, and 5;

each R₅ is independently selected from the group consisting of C₁₋₃ alkyl, C₂₋₃ alkenyl, and H;

each R₆ is independently selected from the group consisting of C₁₋₃ alkyl, C₂₋₃ alkenyl, and H;

M and M' are independently selected from -C(O)O-, -OC(O)-, -OC(O)-M'-C(O)O-, -C(O)N(R')-, -N(R')C(O)-, -C(O)-, -C(S)-, -C(S)S-, -SC(S)-, -CH(OH)-, -P(O)(OR')O-, -S(O)₂-, -S-S-, an aryl group, and a heteroaryl group, in which M' is a bond, C₁₋₁₃ alkyl or C₂₋₁₃ alkenyl;

R₇ is selected from the group consisting of C₁₋₃ alkyl, C₂₋₃ alkenyl, and H;

R₈ is selected from the group consisting of C₃₋₆ carbocycle and heterocycle;

R₉ is selected from the group consisting of H, CN, NO₂, C₁₋₆ alkyl, -OR, -S(O)₂R, -S(O)₂N(R)₂, C₂₋₆ alkenyl, C₃₋₆ carbocycle and heterocycle;

each R is independently selected from the group consisting of C₁₋₃ alkyl, C₂₋₃ alkenyl, and H;

each R' is independently selected from the group consisting of C₁₋₁₈ alkyl, C₂₋₁₈ alkenyl, -R*YR'', -YR'', and H;

each R'' is independently selected from the group consisting of C₃₋₁₅ alkyl and C₃₋₁₅ alkenyl;

each R* is independently selected from the group consisting of C₁₋₁₂ alkyl and C₂₋₁₂ alkenyl;

each Y is independently a C₃₋₆ carbocycle;

each X is independently selected from the group consisting of F, Cl, Br, and I; and

m is selected from 5, 6, 7, 8, 9, 10, 11, 12, and 13; and wherein when R₄ is -(CH₂)_nQ, -(CH₂)_nCHQR, -CHQR, or -CQ(R)₂, then (i) Q is not -N(R)₂ when n is 1, 2, 3, 4 or 5, or (ii) Q is not 5, 6, or 7-membered heterocycloalkyl when n is 1 or 2.

[00284] In some embodiments, a subset of compounds of Formula (IL-I) includes those of Formula (IL-IA):

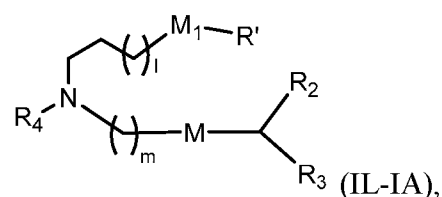

or its N-oxide, or a salt or isomer thereof, wherein l is selected from 1, 2, 3, 4, and 5; m is selected from 5, 6, 7, 8, and 9; M₁ is a bond or M'; R₄ is hydrogen, unsubstituted C₁₋₃ alkyl, or -(CH₂)_nQ, in which Q is OH, -NHC(S)N(R)₂, -NHC(O)N(R)₂, -N(R)C(O)R, -N(R)S(O)₂R, -N(R)R₈, -NHC(=NR₉)N(R)₂, -NHC(=CHR₉)N(R)₂, -OC(O)N(R)₂, -N(R)C(O)OR, heteroaryl or heterocycloalkyl; M and M' are independently selected from -C(O)O-, -OC(O)-, -OC(O)-M'-C(O)O-, -C(O)N(R')-, -P(O)(OR')O-, -S-S-, an aryl group, and a heteroaryl group; and R₂ and R₃ are independently selected from the group consisting of H, C₁₋₁₄ alkyl, and C₂₋₁₄ alkenyl. In some embodiments, m is 5, 7, or 9. In some embodiments, Q is OH, -NHC(S)N(R)₂, or -NHC(O)N(R)₂. In some embodiments, Q is -N(R)C(O)R, or -N(R)S(O)₂R.

[00285] In some embodiments, a subset of compounds of Formula (I) includes those of Formula (IL-IB):

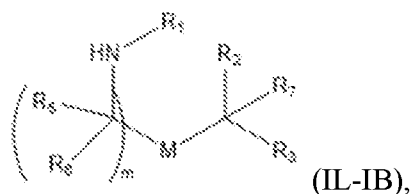

or its N-oxide, or a salt or isomer thereof, in which all variables are as defined herein. In some embodiments, m is selected from 5, 6, 7, 8, and 9; R_4 is hydrogen, unsubstituted C_{1-3} alkyl, or $-(CH_2)_nQ$, in which Q is $-OH$, $-NHC(S)N(R)_2$, $-NHC(O)N(R)_2$, $-N(R)C(O)R$, $-N(R)S(O)_2R$, $-N(R)R_8$, $-NHC(=NR_9)N(R)_2$, $-NHC(=CHR_9)N(R)_2$, $-OC(O)N(R)_2$, $-N(R)C(O)OR$, heteroaryl or heterocycloalkyl; M and M' are independently selected from $-C(O)O-$, $-OC(O)-$, $-OC(O)-M'-C(O)O-$, $-C(O)N(R')$, $-P(O)(OR')O-$, $-S-S-$, an aryl group, and a heteroaryl group; and R_2 and R_3 are independently selected from the group consisting of H, C_{1-14} alkyl, and C_{2-14} alkenyl. In some embodiments, m is 5, 7, or 9. In some embodiments, Q is OH , $-NHC(S)N(R)_2$, or $-NHC(O)N(R)_2$. In some embodiments, Q is $-N(R)C(O)R$, or $-N(R)S(O)_2R$.

[00286] In some embodiments, a subset of compounds of Formula (IL-I) includes those of Formula (IL-II):

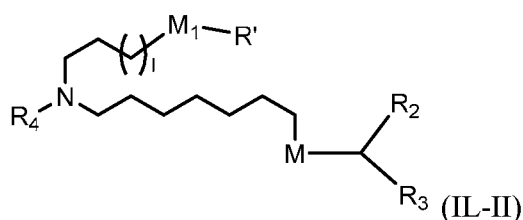

or its N-oxide, or a salt or isomer thereof, wherein l is selected from 1, 2, 3, 4 and 5; M_1 is a bond or M' ; R_4 is hydrogen, unsubstituted C_{1-3} alkyl, or $-(CH_2)_nQ$, in which n is 2, 3, or 4, and Q is $-OH$, $-NHC(S)N(R)_2$, $-NHC(O)N(R)_2$, $-N(R)C(O)R$, $-N(R)S(O)_2R$, $-N(R)R_8$, $-NHC(=NR_9)N(R)_2$, $-NHC(=CHR_9)N(R)_2$, $-OC(O)N(R)_2$, $-N(R)C(O)OR$, heteroaryl or heterocycloalkyl; M and M' are independently selected from $-C(O)O-$, $-OC(O)-$, $-OC(O)-M'-C(O)O-$, $-C(O)N(R')$, $-P(O)(OR')O-$, $-S-S-$, an aryl group, and a heteroaryl group; and R_2 and R_3 are independently selected from the group consisting of H, C_{1-14} alkyl, and C_{2-14} alkenyl.

[00287] In some embodiments, the compounds of Formula (IL-I) are of Formula (IL-IIa):

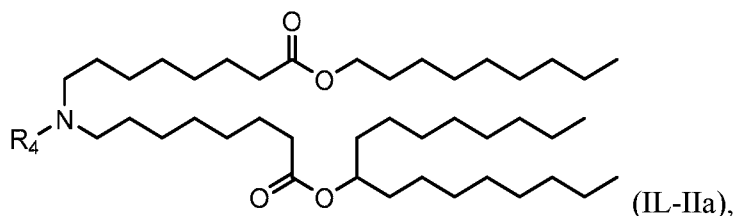

or their N-oxides, or salts or isomers thereof, wherein R₄ is as described herein.

[00288] In another embodiment, the compounds of Formula (IL-I) are of Formula (IL-IIb):

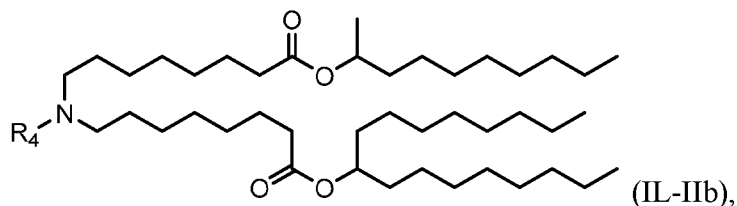

or their N-oxides, or salts or isomers thereof, wherein R₄ is as described herein.

[00289] In another embodiment, the compounds of Formula (IL-I) are of Formula (IL-IIc) or (IL-IIe):

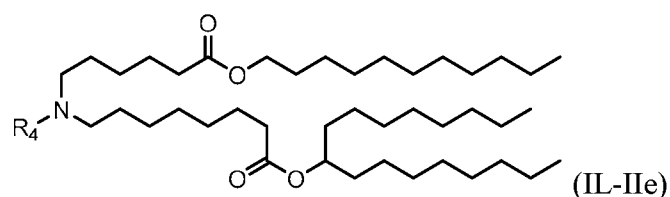
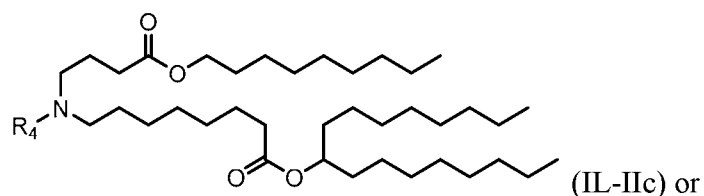

or their N-oxides, or salts or isomers thereof, wherein R₄ is as described herein.

[00290] In another embodiment, the compounds of Formula (IL-I) are of Formula (IL-IIf):

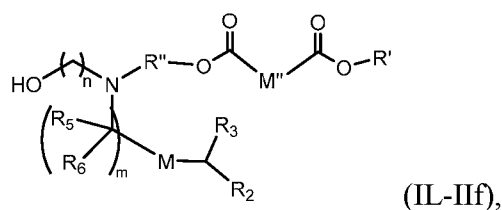

or their N-oxides, or salts or isomers thereof, wherein M is $-\text{C}(\text{O})\text{O}-$ or $-\text{OC}(\text{O})-$, M' is C₁₋₆ alkyl or C₂₋₆ alkenyl, R₂ and R₃ are independently selected from the group consisting of C₅₋₁₄ alkyl and C₅₋₁₄ alkenyl, and n is selected from 2, 3, and 4.

[00291] In a further embodiment, the compounds of Formula (IL-I) are of Formula (IL-IIg):

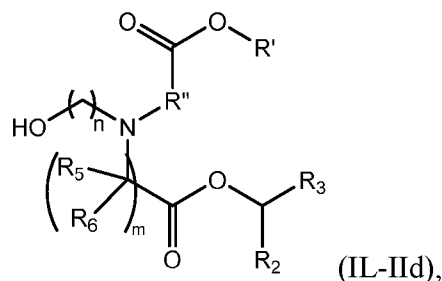

or their N-oxides, or salts or isomers thereof, wherein n is 2, 3, or 4; and m, R', R'', and R₂ through R₆ are as described herein. In some embodiments, each of R₂ and R₃ may be independently selected from the group consisting of C₅₋₁₄ alkyl and C₅₋₁₄ alkenyl.

[00292] In a further embodiment, the compounds of Formula (IL-I) are of Formula (IL-IIg):

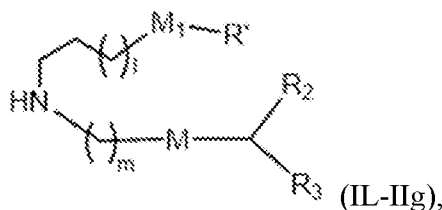

or their N-oxides, or salts or isomers thereof, wherein l is selected from 1, 2, 3, 4, and 5; m is selected from 5, 6, 7, 8, and 9; M₁ is a bond or M'; M and M' are independently selected from -C(O)O-, -OC(O)-, -OC(O)-M'-C(O)O-, -C(O)N(R')-, -P(O)(OR')O-, -S-S-, an aryl group, and a heteroaryl group; and R₂ and R₃ are independently selected from the group consisting of H, C₁₋₁₄ alkyl, and C₂₋₁₄ alkenyl. In some embodiments, M' is C₁₋₆ alkyl (e.g., C₁₋₄ alkyl) or C₂₋₆ alkenyl (e.g. C₂₋₄ alkenyl). In some embodiments, R₂ and R₃ are independently selected from the group consisting of C₅₋₁₄ alkyl and C₅₋₁₄ alkenyl.

[00293] In some embodiments, the ionizable lipids are one or more of the compounds described in U.S. Application Nos. 62/220,091, 62/252,316, 62/253,433, 62/266,460, 62/333,557, 62/382,740, 62/393,940, 62/471,937, 62/471,949, 62/475,140, and 62/475,166, and PCT Application No. PCT/US2016/052352.

[00294] In some embodiments, the ionizable lipids are selected from Compounds 1-280 described in U.S. Application No. 62/475,166.

[00295] In some embodiments, the ionizable lipid is

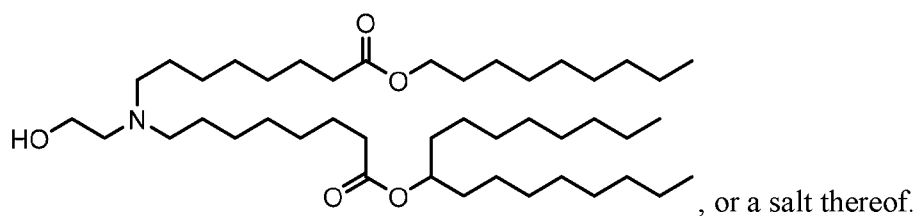

[00296] In some embodiments, the ionizable lipid is

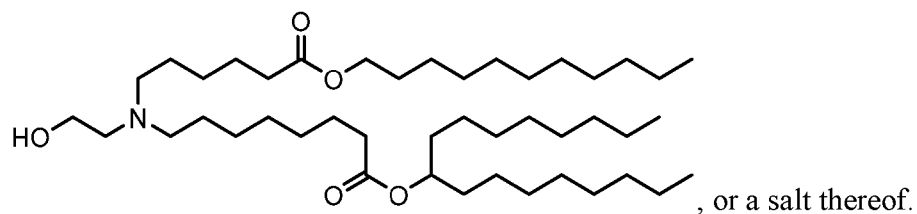

[00297] In some embodiments, the ionizable lipid is

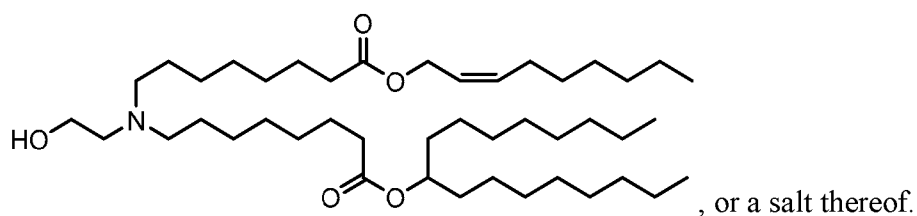

[00298] In some embodiments, the ionizable lipid is

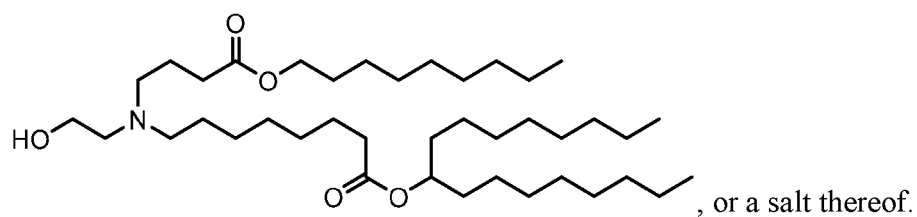

[00299] In some embodiments, the ionizable lipid is

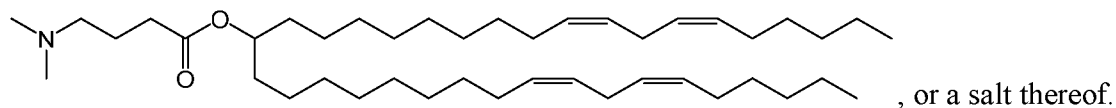

[00300] In some aspects, the ionizable lipids of the present disclosure may be one or more of compounds of formula (IL-III):

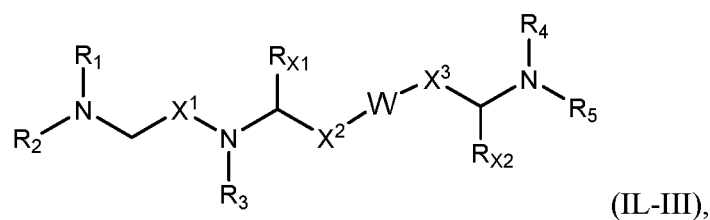

or salts or isomers thereof, wherein,

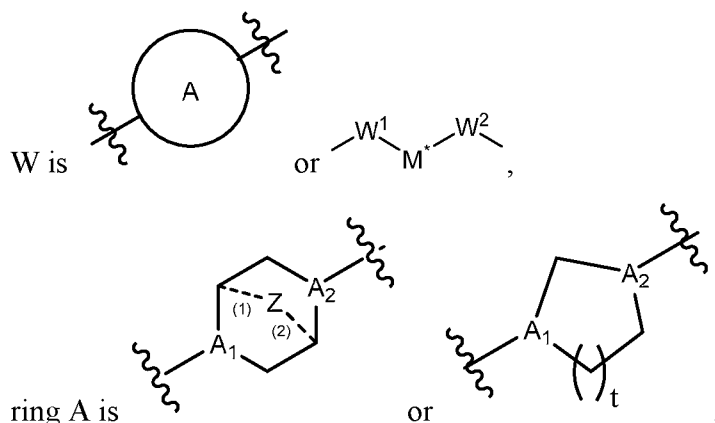

t is 1 or 2;

A₁ and A₂ are each independently selected from CH or N;

Z is CH₂ or absent wherein when Z is CH₂, the dashed lines (1) and (2) each represent a single bond; and when Z is absent, the dashed lines (1) and (2) are both absent;

R₁, R₂, R₃, R₄, and R₅ are independently selected from the group consisting of C₅₋₂₀ alkyl, C₅₋₂₀ alkenyl, -R''MR', -R*YR'', -YR'', and -R*OR'';

R_{X1} and R_{X2} are each independently H or C₁₋₃ alkyl;

each M is independently selected from the group consisting of -C(O)O-, -OC(O)-, -OC(O)O-, -C(O)N(R')-, -N(R')C(O)-, -C(O)-, -C(S)-, -C(S)S-, -SC(S)-, -CH(OH)-, -P(O)(OR')O-, -S(O)₂-, -C(O)S-, -SC(O)-, an aryl group, and a heteroaryl group;

M* is C₁₋₆ alkyl,

W¹ and W² are each independently selected from the group consisting of -O- and -N(R₆)-;

each R₆ is independently selected from the group consisting of H and C₁₋₅ alkyl;

X¹, X², and X³ are independently selected from the group consisting of a bond, -CH₂-, -(CH₂)₂-, -CHR-, -CHY-, -C(O)-, -C(O)O-, -OC(O)-, -(CH₂)_n-C(O)-, -C(O)-(CH₂)_n-, -(CH₂)_n-C(O)O-, -OC(O)-(CH₂)_n-, -(CH₂)_n-OC(O)-, -C(O)O-(CH₂)_n-, -CH(OH)-, -C(S)-, and -CH(SH)-;

each Y is independently a C₃₋₆ carbocycle;

each R* is independently selected from the group consisting of C₁₋₁₂ alkyl and C₂₋₁₂ alkenyl;

each R is independently selected from the group consisting of C₁₋₃ alkyl and a C₃₋₆ carbocycle;

each R' is independently selected from the group consisting of C₁₋₁₂ alkyl, C₂₋₁₂ alkenyl, and H;

each R'' is independently selected from the group consisting of C₃₋₁₂ alkyl, C₃₋₁₂ alkenyl and -R*MR'; and

n is an integer from 1-6;

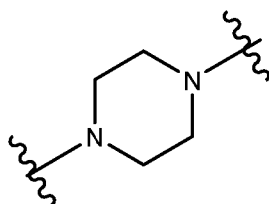

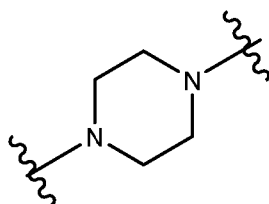
wherein when ring A is , then

i) at least one of X¹, X², and X³ is not -CH₂-; and/or

ii) at least one of R₁, R₂, R₃, R₄, and R₅ is -R''MR'.

[00301] In some embodiments, the compound is of any of formulae (IL-IIIa1)-(IL-IIIa8):

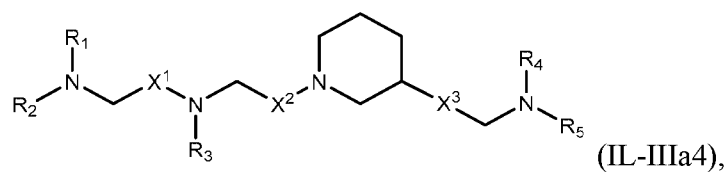
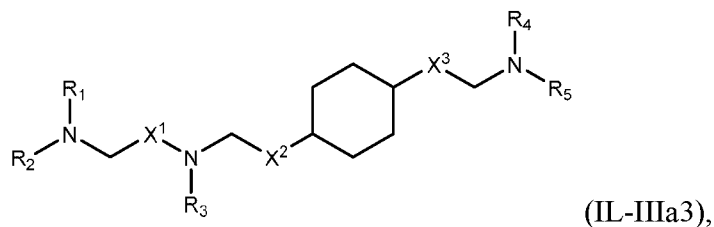
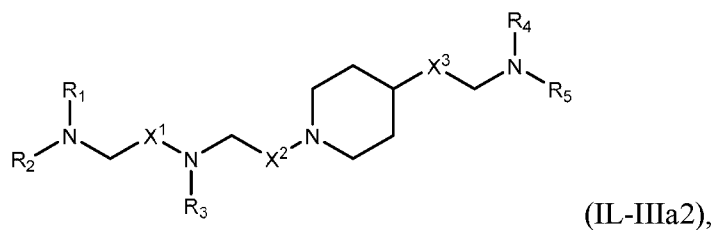
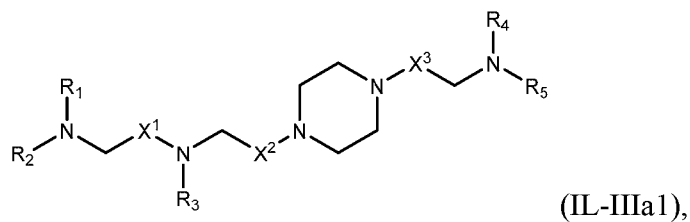

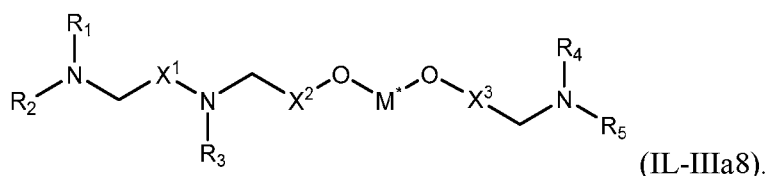
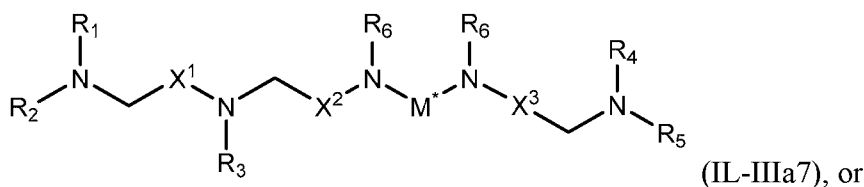
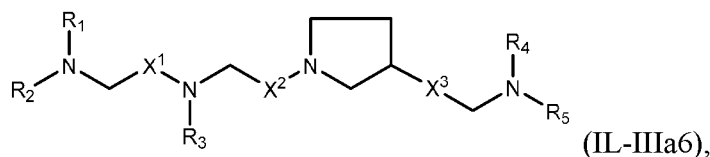
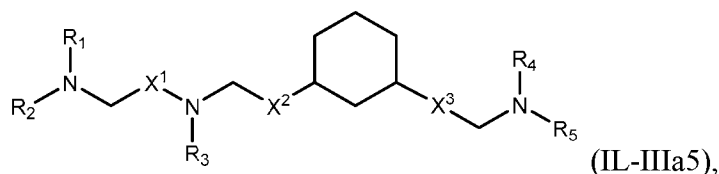

[00302] In some embodiments, the ionizable lipids are one or more of the compounds described in U.S. Application Nos. 62/271,146, 62/338,474, 62/413,345, and 62/519,826, and PCT Application No. PCT/US2016/068300.

[00303] In some embodiments, the ionizable lipids are selected from Compound 1-156 described in U.S. Application No. 62/519,826.

[00304] In some embodiments, the ionizable lipids are selected from Compounds 1-16, 42-66, 68-76, and 78-156 described in U.S. Application No. 62/519,826.

[00305] In some embodiments, the ionizable lipid is

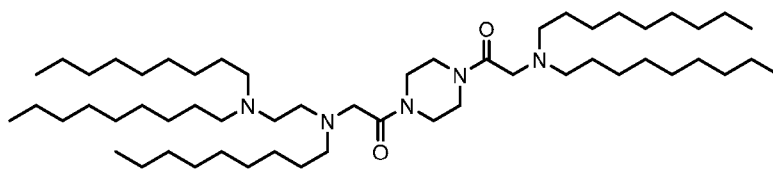

, or a salt thereof.

[00306] The central amine moiety of a lipid according to Formula (IL-1), (IL-IA), (IL-IB), (IL-II), (IL-IIa), (IL-IIb), (IL-IIc), (IL-IId), (IL-IIe), (IL-IIf), (IL-IIg), (IL-III), (IL-IIIa1), (IL-IIIa2), (IL-IIIa3), (IL-IIIa4), (IL-IIIa5), (IL-IIIa6), (IL-IIIa7), or (IL-IIIa8) may be protonated at a physiological pH. Thus, a lipid may have a positive or partial positive charge at physiological pH. Such lipids may be referred to as cationic or ionizable (amino)lipids. Lipids may also be zwitterionic, i.e., neutral molecules having both a positive and a negative charge.

Polyethylene Glycol (PEG) Lipids

[00307] As used herein, the term “PEG lipid” refers to polyethylene glycol (PEG)-modified lipids. Non-limiting examples of PEG lipids include PEG-modified phosphatidylethanolamine and phosphatidic acid, PEG-ceramide conjugates (e.g., PEG-CerC14 or PEG-CerC20), PEG-modified dialkylamines and PEG-modified 1,2-diacloxypropan-3-amines. Such lipids are also referred to as PEGylated lipids. In some embodiments, a PEG lipid can be PEG-c-DOMG, PEG-DMG, PEG-DLPE, PEG-DMPE, PEG-DPPC, or a PEG-DSPE lipid.

[00308] In some embodiments, the PEG lipid includes, but are not limited to, 1,2-dimyristoyl-sn-glycerol methoxypolyethylene glycol (PEG-DMG), 1,2-distearoyl-sn-glycero-3-phosphoethanolamine-N-[amino(polyethylene glycol)] (PEG-DSPE), PEG-disteryl glycerol (PEG-DSG), PEG-dipalmetoleyl, PEG-dioleyl, PEG-distearyl, PEG-diacylglycamide (PEG-DAG), PEG-dipalmitoyl phosphatidylethanolamine (PEG-DPPE), or PEG-1,2-dimyristyloxylpropyl-3-amine (PEG-c-DMA).

[00309] In some embodiments, the PEG lipid is selected from the group consisting of a PEG-modified phosphatidylethanolamine, a PEG-modified phosphatidic acid, a PEG-modified ceramide, a PEG-modified dialkylamine, a PEG-modified diacylglycerol, a PEG-modified dialkylglycerol, and mixtures thereof.

[00310] In some embodiments, the lipid moiety of the PEG lipids includes those having lengths of from about C₁₄ to about C₂₂, preferably from about C₁₄ to about C₁₆. In some embodiments, a PEG moiety, for example an mPEG-NH₂, has a size of about 1000, 2000, 5000, 10,000, 15,000 or 20,000 daltons. In some embodiments, the PEG lipid is PEG_{2k}-DMG.

[00311] In some embodiments, the lipid nanoparticles described herein can comprise a PEG lipid which is a non-diffusible PEG. Non-limiting examples of non-diffusible PEGs include PEG-DSG and PEG-DSPE.

[00312] PEG lipids are known in the art, such as those described in U.S. Patent No. 8158601 and International Publ. No. WO 2015/130584 A2, which are incorporated herein by reference in their entireties.

[00313] In general, some of the other lipid components (e.g., PEG lipids) of various formulae, described herein may be synthesized as described International Patent Application No.

PCT/US2016/000129, filed December 10, 2016, entitled “Compositions and Methods for Delivery of Therapeutic Agents,” which is incorporated by reference in its entirety.

[00314] The lipid component of a lipid nanoparticle composition may include one or more molecules comprising polyethylene glycol, such as PEG or PEG-modified lipids. Such species may be alternately referred to as PEGylated lipids. A PEG lipid is a lipid modified with polyethylene glycol. A PEG lipid may be selected from the non-limiting group including PEG-modified phosphatidylethanolamines, PEG-modified phosphatidic acids, PEG-modified ceramides, PEG-modified dialkylamines, PEG-modified diacylglycerols, PEG-modified dialkylglycerols, and mixtures thereof. In some embodiments, a PEG lipid may be PEG-c-DOMG, PEG-DMG, PEG-DLPE, PEG-DMPE, PEG-DPPC, or a PEG-DSPE lipid.

[00315] In some embodiments, the PEG-modified lipids are a modified form of PEG DMG. PEG-DMG has the following structure:

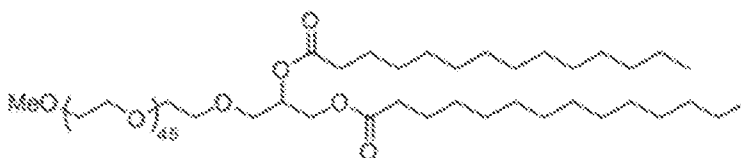

[00316] In some embodiments, PEG lipids useful in the present invention can be PEGylated lipids described in International Publication No. WO2012099755, the contents of which is herein incorporated by reference in its entirety. Any of these exemplary PEG lipids described herein may be modified to comprise a hydroxyl group on the PEG chain. In some embodiments, the PEG lipid is a PEG-OH lipid. As generally defined herein, a “PEG-OH lipid” (also referred to herein as “hydroxy-PEGylated lipid”) is a PEGylated lipid having one or more hydroxyl (–OH) groups on the lipid. In some embodiments, the PEG-OH lipid includes one or more hydroxyl groups on the PEG chain. In some embodiments, a PEG-OH or hydroxy-PEGylated lipid comprises an –OH group at the terminus of the PEG chain. Each possibility represents a separate embodiment of the present invention.

[00317] In some embodiments, a PEG lipid useful in the present invention is a compound of Formula (PL-I). Provided herein are compounds of Formula (PL-I):

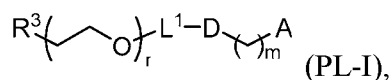

or salts thereof, wherein:

R^3 is $-\text{OR}^0$;

R^O is hydrogen, optionally substituted alkyl, or an oxygen protecting group;

r is an integer between 1 and 100, inclusive;

L^1 is optionally substituted C_{1-10} alkylene, wherein at least one methylene of the optionally substituted C_{1-10} alkylene is independently replaced with optionally substituted carbocyclylene, optionally substituted heterocyclylene, optionally substituted arylene, optionally substituted heteroarylene, O, $N(R^N)$, S, C(O), C(O) $N(R^N)$, $NR^N C(O)$, C(O)O, OC(O), OC(O)O, OC(O) $N(R^N)$, $NR^N C(O)O$, or $NR^N C(O)N(R^N)$;

D is a moiety obtained by click chemistry or a moiety cleavable under physiological conditions;

m is 0, 1, 2, 3, 4, 5, 6, 7, 8, 9, or 10;

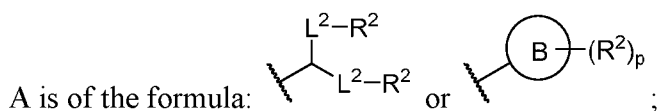

each instance of L^2 is independently a bond or optionally substituted C_{1-6} alkylene, wherein one methylene unit of the optionally substituted C_{1-6} alkylene is optionally replaced with O, $N(R^N)$, S, C(O), C(O) $N(R^N)$, $NR^N C(O)$, C(O)O, OC(O), OC(O)O, OC(O) $N(R^N)$, $NR^N C(O)O$, or $NR^N C(O)N(R^N)$;

each instance of R^2 is independently optionally substituted C_{1-30} alkyl, optionally substituted C_{1-30} alkenyl, or optionally substituted C_{1-30} alkynyl; optionally wherein one or more methylene units of R^2 are independently replaced with optionally substituted carbocyclylene, optionally substituted heterocyclylene, optionally substituted arylene, optionally substituted heteroarylene, $N(R^N)$, O, S, C(O), C(O) $N(R^N)$, $NR^N C(O)$, $NR^N C(O)N(R^N)$, C(O)O, OC(O), -OC(O)O, OC(O) $N(R^N)$, $NR^N C(O)O$, C(O)S, SC(O), C(=NR^N), C(=NR^N) $N(R^N)$, $NR^N C(=NR^N)$, $NR^N C(=NR^N)N(R^N)$, C(S), C(S) $N(R^N)$, $NR^N C(S)$, $NR^N C(S)N(R^N)$, S(O), OS(O), S(O)O, -OS(O)O, OS(O)₂, S(O)₂O, OS(O)₂O, $N(R^N)S(O)$, S(O) $N(R^N)$, $N(R^N)S(O)N(R^N)$, OS(O) $N(R^N)$, $N(R^N)S(O)O$, S(O)₂, $N(R^N)S(O)$ ₂, S(O)₂ $N(R^N)$, $N(R^N)S(O)$ ₂ $N(R^N)$, OS(O)₂ $N(R^N)$, or - $N(R^N)S(O)$ ₂O;

each instance of R^N is independently hydrogen, optionally substituted alkyl, or a nitrogen protecting group;

Ring B is optionally substituted carbocyclyl, optionally substituted heterocyclyl, optionally substituted aryl, or optionally substituted heteroaryl; and

p is 1 or 2.

[00318] In some embodiments, the compound of Formula (PL-I) is a PEG-OH lipid (*i.e.*, R³ is -OR^O, and R^O is hydrogen). In some embodiments, the compound of Formula (PL-I) is of Formula (PL-I-OH):

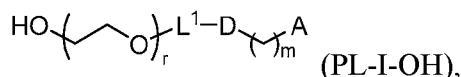

or a salt thereof.

[00319] In some embodiments, a PEG lipid useful in the present invention is a PEGylated fatty acid. In some embodiments, a PEG lipid useful in the present invention is a compound of Formula (PL-II). Provided herein are compounds of Formula (PL-II):

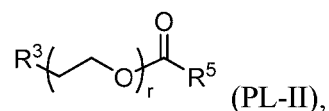

or a salt thereof, wherein:

R³ is -OR^O;

R^O is hydrogen, optionally substituted alkyl or an oxygen protecting group;

r is an integer between 1 and 100, inclusive;

R⁵ is optionally substituted C₁₀₋₄₀ alkyl, optionally substituted C₁₀₋₄₀ alkenyl, or optionally substituted C₁₀₋₄₀ alkynyl; and optionally one or more methylene groups of R⁵ are replaced with optionally substituted carbocyclylene, optionally substituted heterocyclylene, optionally substituted arylene, optionally substituted heteroarylene, N(R^N), O, S, C(O), C(O)N(R^N), -NR^NC(O), NR^NC(O)N(R^N), C(O)O, OC(O), OC(O)O, OC(O)N(R^N), NR^NC(O)O, C(O)S, SC(O), C(=NR^N), C(=NR^N)N(R^N), NR^NC(=NR^N), NR^NC(=NR^N)N(R^N), C(S), C(S)N(R^N), NR^NC(S), -NR^NC(S)N(R^N), S(O), OS(O), S(O)O, OS(O)O, OS(O)₂, S(O)₂O, OS(O)₂O, N(R^N)S(O), -S(O)N(R^N), N(R^N)S(O)N(R^N), OS(O)N(R^N), N(R^N)S(O)O, S(O)₂, N(R^N)S(O)₂, S(O)₂N(R^N), -N(R^N)S(O)₂N(R^N), OS(O)₂N(R^N), or N(R^N)S(O)₂O; and

each instance of R^N is independently hydrogen, optionally substituted alkyl, or a nitrogen protecting group.

[00320] In some embodiments, the compound of Formula (PL-II) is of Formula (PL-II-OH):

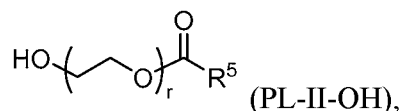

or a salt thereof. In some embodiments, r is 45.

[00321] In some embodiments, the compound of Formula (PL-II) is:

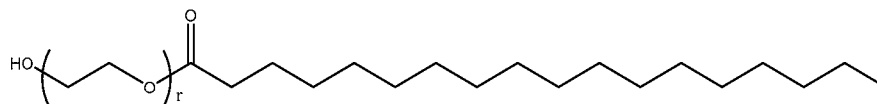

or a salt thereof.

[00322] In some embodiments, the compound of Formula (PL-II) is

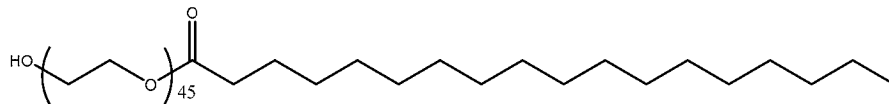

[00323] In some embodiments, the PEG lipid may be one or more of the PEG lipids described in U.S. Application No. 62/520,530.

[00324] In some embodiments, a PEG lipid useful in the present invention is a compound of Formula (PL-IV):

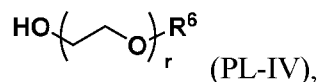

or salts thereof, wherein:

R^6 is C_1 - C_{20} alkyl;

r is an integer between 0 and 100, inclusive.

[00325] In some embodiments, r is 0.

[00326] In some embodiments, R^6 is C_{16} alkyl.

[00327] In some embodiments, R^6 is C_{18} alkyl.

[00328] In some embodiments, the compound of Formula (PL-IV) is

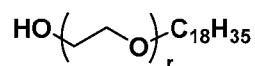

[00329] In some embodiments, the compound of Formula (PL-IV) is BRIJ® C2 (*e.g.* polyoxyethylene cetyl ether).

[00330] In some embodiments, the compound of Formula (PL-IV) is BRIJ® O2 (*e.g.* polyoxyethylene cetyl ether).

[00331] In some embodiments, the compound of Formula (PL-IV) is

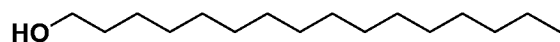

[00332] In some aspects, the lipid composition of the pharmaceutical compositions described herein does not comprise a PEG lipid.

Structural Lipids

[00333] As used herein, the term “structural lipid” refers to sterols and also to lipids containing sterol moieties.

[00334] Without wishing to be bound by theory, incorporation of a structural lipid in the lipid nanoparticle may help mitigate aggregation of other lipids in the particle. Structural lipids can be selected from the group including but not limited to, cholesterol, fecosterol, sitosterol, ergosterol, campesterol, stigmasterol, brassicasterol, tomatidine, tomatine, ursolic acid, alpha-tocopherol, hopanoids, phytosterols, steroids, and mixtures thereof. In some embodiments, the structural lipid is a sterol. As defined herein, “sterols” are a subgroup of steroids consisting of steroid alcohols. In some embodiments, the structural lipid is a steroid. In some embodiments, the structural lipid is cholesterol. In some embodiments, the structural lipid is an analog of cholesterol. In some embodiments, the structural lipid is alpha-tocopherol.

[00335] In some embodiments, the structural lipids may be one or more structural lipids described in U.S. Application No. 62/520,530.

Encapsulation Agent

[00336] In some embodiments of the present disclosure, the encapsulation agent is a compound of Formula (EA-I):

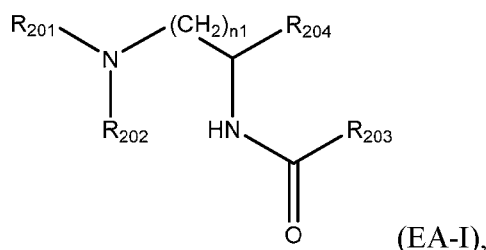

or salts or isomers thereof, wherein

R_{201} and R_{202} are each independently selected from the group consisting of H, C₁-C₆ alkyl, C₂-C₆ alkenyl, and (C=NH)N(R_{101})₂ wherein each R_{101} is independently selected from the group consisting of H, C₁-C₆ alkyl, and C₂-C₆ alkenyl;

R_{203} is selected from the group consisting of C₁-C₂₀ alkyl and C₂-C₂₀ alkenyl;

R_{204} is selected from the group consisting of H, C₁-C₂₀ alkyl, C₂-C₂₀ alkenyl, C(O)(OC₁-C₂₀ alkyl), C(O)(OC₂-C₂₀ alkenyl), C(O)(NHC₁-C₂₀ alkyl), and C(O)(NHC₂-C₂₀ alkenyl);

n_1 is selected from 1, 2, 3, 4, 5, 6, 7, 8, 9, and 10.

[00337] In some embodiments, R_{201} and R_{202} are each independently selected from the group consisting of H and CH_3 .

[00338] In some embodiments, R_{201} and R_{202} are each independently selected from the group consisting of $(C=NH)NH_2$ and $(C=NH)N(CH_3)_2$

[00339] In some embodiments, R_{203} is selected from the group consisting of C_1 - C_{20} alkyl, C_8 - C_{18} alkyl, and C_{12} - C_{16} alkyl.

[00340] In some embodiments, R_{204} is selected from the group consisting of H, C_1 - C_{20} alkyl, C_2 - C_{20} alkenyl, $C(O)(OC_1-C_{20}$ alkyl), $C(O)(OC_2-C_{20}$ alkenyl), $C(O)(NHC_1-C_{20}$ alkyl), and $C(O)(NHC_2-C_{20}$ alkenyl); C_8 - C_{18} alkyl, C_8 - C_{18} alkenyl, $C(O)(OC_8-C_{18}$ alkyl), $C(O)(OC_8-C_{18}$ alkenyl), $C(O)(NHC_8-C_{18}$ alkyl), and $C(O)(NHC_8-C_{18}$ alkenyl); and C_{12} - C_{16} alkyl, C_{12} - C_{16} alkenyl, $C(O)(OC_{12}-C_{16}$ alkyl), $C(O)(OC_{12}-C_{16}$ alkenyl), $C(O)(NHC_{12}-C_{16}$ alkyl), and $C(O)(NHC_{12}-C_{16}$ alkenyl);

[00341] In some embodiments, n_1 is selected from 1, 2, 3, 4, 5, 6, 7, 8, 9, and 10; n_1 is selected from 1, 2, 3, 4, 5, and 6; n_1 is selected from 2, 3, and 4.

[00342] In some embodiments, n_1 is 3.

[00343] In some embodiments of the present disclosure, the encapsulation agent is a compound of Formula (EA-II):

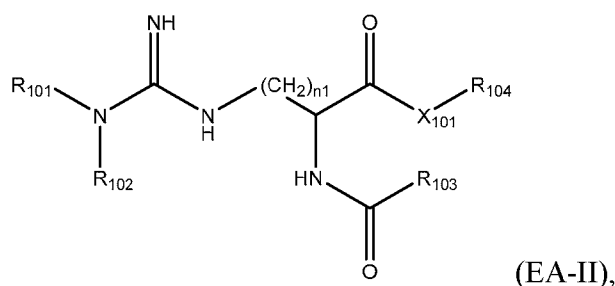

or salts or isomers thereof, wherein

X_{101} is a bond, NH, or O;

R_{101} and R_{102} are each independently selected from the group consisting of H, C_1 - C_6 alkyl, and C_2 - C_6 alkenyl;

R_{103} and R_{104} are each independently selected from the group consisting of C_1 - C_{20} alkyl and C_2 - C_{20} alkenyl; and

n_1 is selected from 1, 2, 3, 4, 5, 6, 7, 8, 9, and 10.

[00344] In some embodiments, X_{101} is a bond.

[00345] In some embodiments, X_{101} is NH.

- [00346] In some embodiments, X₁₀₁ is O.
- [00347] In some embodiments, R₁₀₁ and R₁₀₂ are each independently selected from the group consisting of H and CH₃.
- [00348] In some embodiments, R₁₀₃ is selected from the group consisting of C₁-C₂₀ alkyl, C₈-C₁₈ alkyl, and C₁₂-C₁₆ alkyl.
- [00349] In some embodiments, R₁₀₄ is selected from the group consisting of C₁-C₂₀ alkyl, C₈-C₁₈ alkyl, and C₁₂-C₁₆ alkyl.
- [00350] In some embodiments, n₁ is selected from 1, 2, 3, 4, 5, 6, 7, 8, 9, and 10; n₁ is selected from 1, 2, 3, 4, 5, and 6; or n₁ is selected from 2, 3, and 4.
- [00351] In some embodiments, n₁ is 3.
- [00352] Exemplary encapsulation agents include, but are not limited to, ethyl lauroyl arginate, ethyl myristoyl arginate, ethyl palmitoyl arginate, ethyl oleic arginate, ethyl capric arginate, and ethyl carpyrylic arginate.
- [00353] In certain embodiments, the encapsulation agent is ethyl lauroyl arginate,

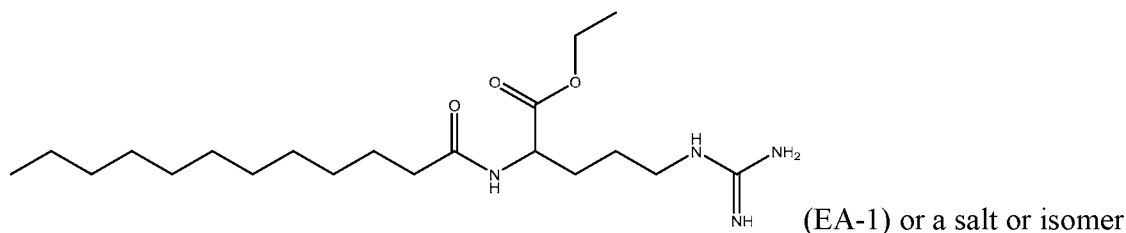

thereof.

- [00354] In certain embodiments, the encapsulation agent is at least one compound selected from the group consisting of:

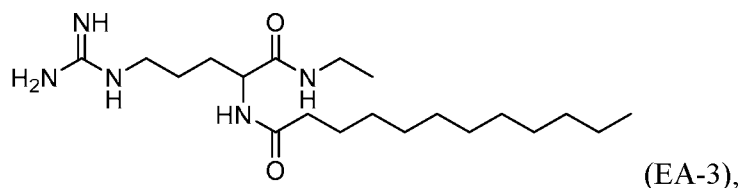
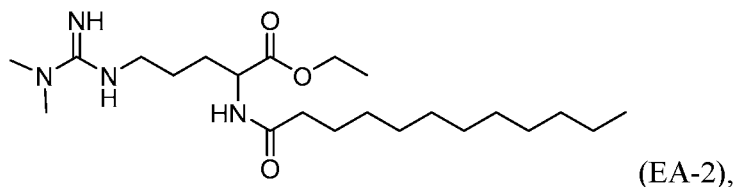

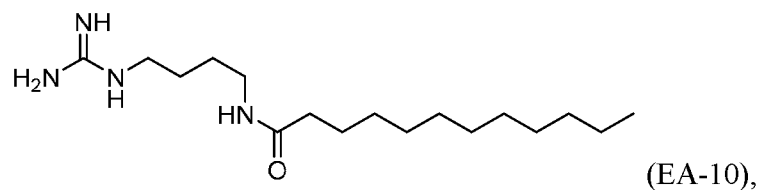
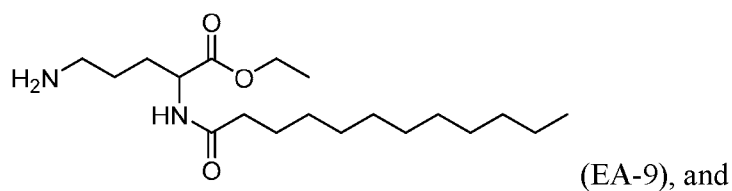
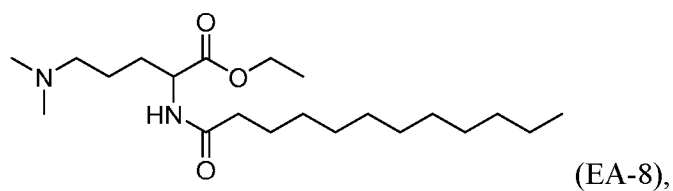
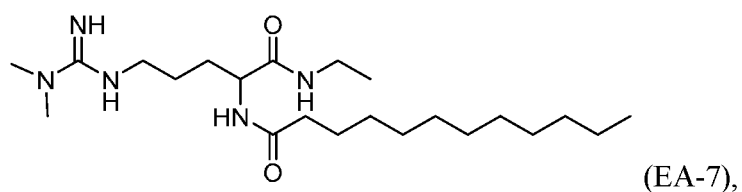
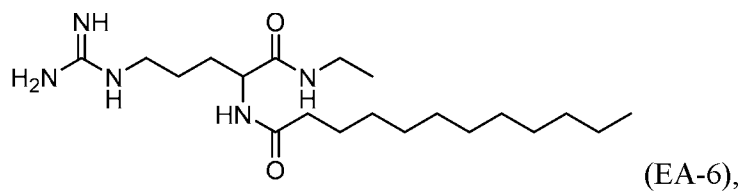
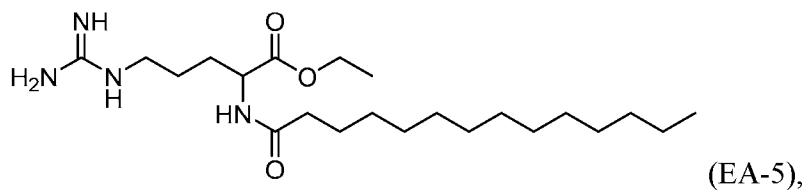
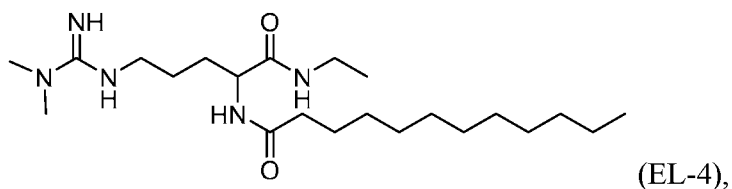

or salts and isomers thereof, such as, for example free bases, TFA salts, and/or HCl salts.

[00355] In some embodiments of the present disclosure, the encapsulation agent is a compound of Formula (EA-III):

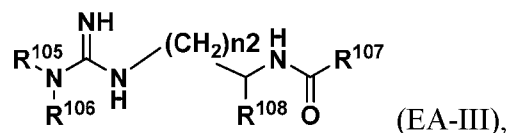

or salts or isomers thereof, wherein

R¹⁰⁵ and R¹⁰⁶ are each independently selected from the group consisting of H, C₁-C₆ alkyl, and C₂-C₆ alkenyl;

R¹⁰⁷ is selected from the group consisting of C₁-C₂₀ alkyl and C₂-C₂₀ alkenyl;

R¹⁰⁸ is selected from the group consisting of H and C(O)NR¹⁰⁹R¹¹⁰;

R¹⁰⁹ and R¹¹⁰ are each independently selected from the group consisting of H, C₁-C₆ alkyl, and C₂-C₆ alkenyl; and

n₂ is selected from 1, 2, 3, 4, 5, 6, 7, 8, 9, and 10.

[00356] In some embodiments, R¹⁰⁵ and R¹⁰⁶ are each independently selected from the group consisting of H and CH₃.

[00357] In some embodiments, R¹⁰⁷ is selected from the group consisting of C₁-C₂₀ alkyl, C₈-C₁₈ alkyl, and C₁₂-C₁₆ alkyl.

[00358] In some embodiments, n₂ is selected from 1, 2, 3, 4, 5, 6, 7, 8, 9, and 10.

[00359] In some embodiments, n₂ is selected from 1, 2, 3, 4, 5, and 6.

[00360] In some embodiments, n₂ is selected from 2, 3, and 4.

[00361] In some embodiments, n₂ is 3.

[00362] Exemplary encapsulation agents include, but are not limited to, EA-11, EA-12, EA-13, and EA-14.

[00363] In certain embodiments, the encapsulation agent is at least one compound selected from the group consisting of:

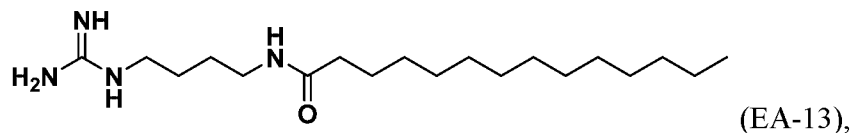
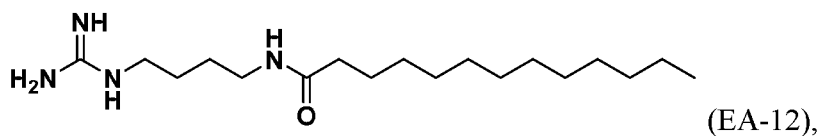
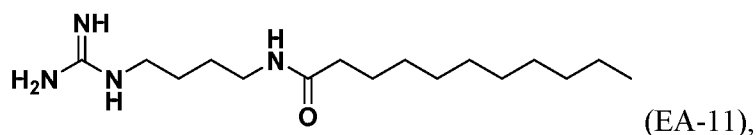

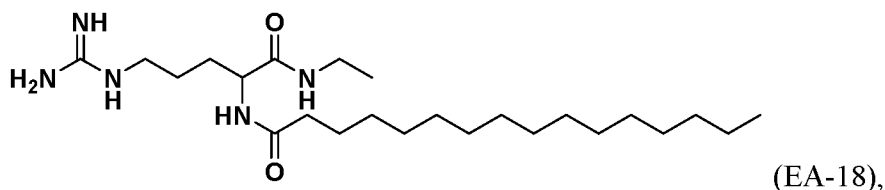
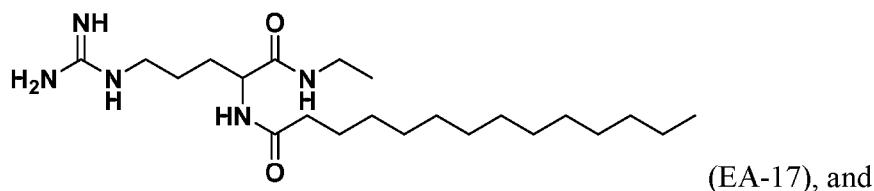
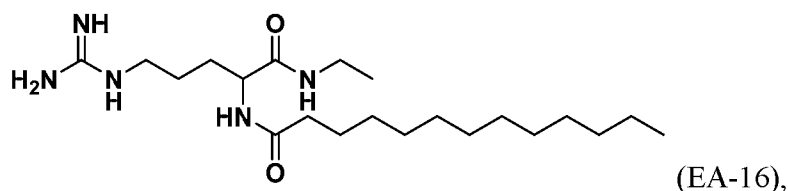
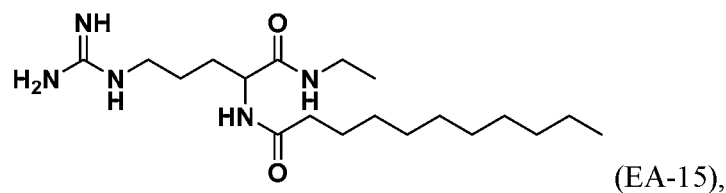
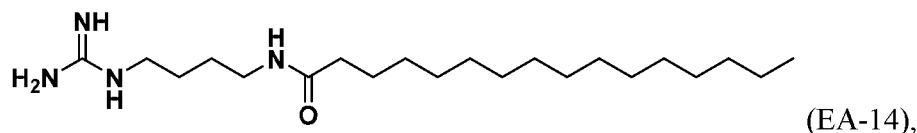

or salts and isomers thereof, such as, for example free bases, TFA salts, and/or HCl salts.

Phospholipids

[00364] Phospholipids may assemble into one or more lipid bilayers. In general, phospholipids comprise a phospholipid moiety and one or more fatty acid moieties.

[00365] A phospholipid moiety can be selected, for example, from the non-limiting group consisting of phosphatidyl choline, phosphatidyl ethanolamine, phosphatidyl glycerol, phosphatidyl serine, phosphatidic acid, 2-lysophosphatidyl choline, and a sphingomyelin.

[00366] A fatty acid moiety can be selected, for example, from the non-limiting group consisting of lauric acid, myristic acid, myristoleic acid, palmitic acid, palmitoleic acid, stearic acid, oleic acid, linoleic acid, alpha-linolenic acid, erucic acid, phytanoic acid, arachidic acid, arachidonic acid, eicosapentaenoic acid, behenic acid, docosapentaenoic acid, and docosahexaenoic acid.

[00367] Particular phospholipids can facilitate fusion to a membrane. In some embodiments, a cationic phospholipid can interact with one or more negatively charged phospholipids of a membrane (e.g., a cellular or intracellular membrane). Fusion of a phospholipid to a membrane can allow one or more elements (e.g., a therapeutic agent) of a lipid-containing composition (e.g., LNPs) to pass through the membrane permitting, e.g., delivery of the one or more elements to a target tissue.

[00368] Non-natural phospholipid species including natural species with modifications and substitutions including branching, oxidation, cyclization, and alkynes are also contemplated. In some embodiments, a phospholipid can be functionalized with or cross-linked to one or more alkynes (e.g., an alkenyl group in which one or more double bonds is replaced with a triple bond). Under appropriate reaction conditions, an alkyne group can undergo a copper-catalyzed cycloaddition upon exposure to an azide. Such reactions can be useful in functionalizing a lipid bilayer of a nanoparticle composition to facilitate membrane permeation or cellular recognition or in conjugating a nanoparticle composition to a useful component such as a targeting or imaging moiety (e.g., a dye).

[00369] Phospholipids include, but are not limited to, glycerophospholipids such as phosphatidylcholines, phosphatidylethanolamines, phosphatidylserines, phosphatidylinositols, phosphatidyl glycerols, and phosphatidic acids. Phospholipids also include phosphosphingolipid, such as sphingomyelin.

[00370] In some embodiments, a phospholipid useful or potentially useful in the present invention is an analog or variant of DSPC. In some embodiments, a phospholipid useful or potentially useful in the present invention is a compound of Formula (PL-I):

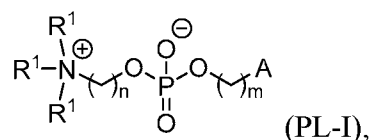

or a salt thereof, wherein:

each R^1 is independently optionally substituted alkyl; or optionally two R^1 are joined together with the intervening atoms to form optionally substituted monocyclic carbocyclyl or optionally substituted monocyclic heterocyclyl; or optionally three R^1 are joined together with the intervening atoms to form optionally substituted bicyclic carbocyclyl or optionally substituted bicyclic heterocyclyl;

n is 1, 2, 3, 4, 5, 6, 7, 8, 9, or 10;

m is 0, 1, 2, 3, 4, 5, 6, 7, 8, 9, or 10;

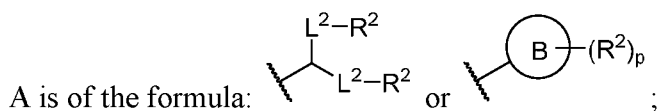

each instance of L^2 is independently a bond or optionally substituted C_{1-6} alkylene, wherein one methylene unit of the optionally substituted C_{1-6} alkylene is optionally replaced with $-O-$, $-N(R^N)-$, $-S-$, $-C(O)-$, $-C(O)N(R^N)-$, $-NR^NC(O)-$, $-C(O)O-$, $-OC(O)-$, $-OC(O)O-$, $-OC(O)N(R^N)-$, $-NR^NC(O)O-$, or $-NR^NC(O)N(R^N)-$;

each instance of R^2 is independently optionally substituted C_{1-30} alkyl, optionally substituted C_{1-30} alkenyl, or optionally substituted C_{1-30} alkynyl; optionally wherein one or more methylene units of R^2 are independently replaced with optionally substituted carbocyclylene, optionally substituted heterocyclylene, optionally substituted arylene, optionally substituted heteroarylene, $-N(R^N)-$, $-O-$, $-S-$, $-C(O)-$, $-C(O)N(R^N)-$, $-NR^NC(O)-$, $-NR^NC(O)N(R^N)-$, $-C(O)O-$, $-OC(O)-$, $-OC(O)O-$, $-OC(O)N(R^N)-$, $-NR^NC(O)O-$, $-C(O)S-$, $-SC(O)-$, $-C(=NR^N)-$, $-C(=NR^N)N(R^N)-$, $-NR^NC(=NR^N)-$, $-NR^NC(=NR^N)N(R^N)-$, $-C(S)-$, $-C(S)N(R^N)-$, $-NR^NC(S)-$, $-NR^NC(S)N(R^N)-$, $-S(O)-$, $-OS(O)-$, $-S(O)O-$, $-OS(O)O-$, $-OS(O)_2-$, $-S(O)_2O-$, $-OS(O)_2O-$, $-N(R^N)S(O)-$, $-S(O)N(R^N)-$, $-N(R^N)S(O)N(R^N)-$, $-OS(O)N(R^N)-$, $-N(R^N)S(O)O-$, $-S(O)_2-$, $-N(R^N)S(O)_2-$, $-S(O)_2N(R^N)-$, $-N(R^N)S(O)_2N(R^N)-$, $-OS(O)_2N(R^N)-$, or $-N(R^N)S(O)_2O-$;

each instance of R^N is independently hydrogen, optionally substituted alkyl, or a nitrogen protecting group;

Ring B is optionally substituted carbocyclyl, optionally substituted heterocyclyl, optionally substituted aryl, or optionally substituted heteroaryl; and

p is 1 or 2;

provided that the compound is not of the formula:

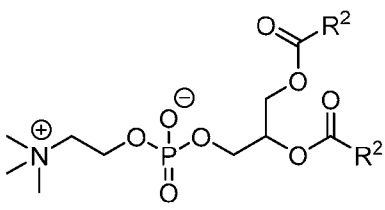

wherein each instance of R^2 is independently unsubstituted alkyl, unsubstituted alkenyl, or unsubstituted alkynyl.

[00371] In some embodiments, the phospholipids may be one or more of the phospholipids described in U.S. Application No. 62/520,530.

i) Phospholipid Head Modifications

[00372] In some embodiments, a phospholipid useful or potentially useful in the present invention comprises a modified phospholipid head (*e.g.*, a modified choline group). In some embodiments, a phospholipid with a modified head is DSPC, or analog thereof, with a modified quaternary amine. In some embodiments, in embodiments of Formula (PL-I), at least one of R¹ is not methyl. In some embodiments, at least one of R¹ is not hydrogen or methyl. In some embodiments, the compound of Formula (PL-I) is one of the following formulae:

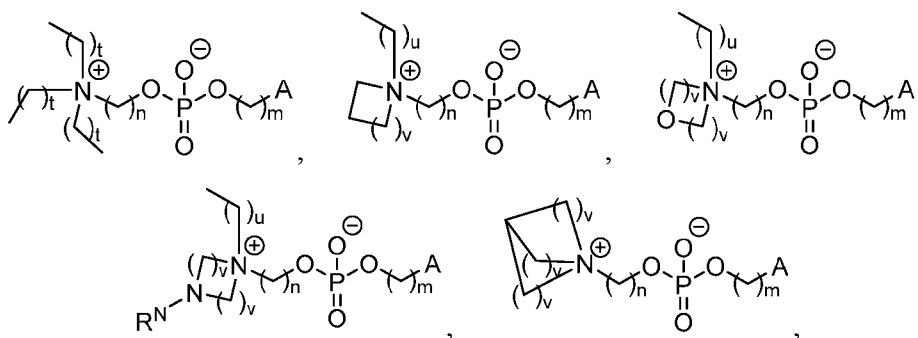

or a salt thereof, wherein:

each t is independently 1, 2, 3, 4, 5, 6, 7, 8, 9, or 10;

each u is independently 0, 1, 2, 3, 4, 5, 6, 7, 8, 9, or 10; and

each v is independently 1, 2, or 3.

In some embodiments, a compound of Formula (PL-I) is of Formula (PL-I-a):

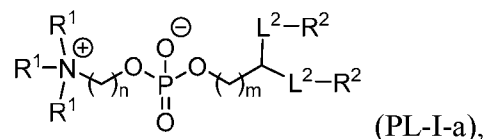

or a salt thereof.

[00373] In some embodiments, a phospholipid useful or potentially useful in the present invention comprises a cyclic moiety in place of the glyceride moiety. In some embodiments, a phospholipid useful in the present invention is DSPC, or analog thereof, with a cyclic moiety in place of the glyceride moiety. In some embodiments, the compound of Formula (PL-I) is of Formula (PL-I-b):

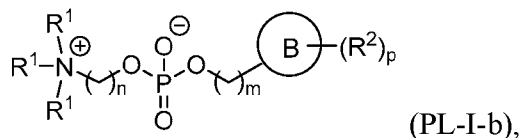

or a salt thereof.

ii) Phospholipid Tail Modifications

[00374] In some embodiments, a phospholipid useful or potentially useful in the present invention comprises a modified tail. In some embodiments, a phospholipid useful or potentially useful in the present invention is DSPC, or analog thereof, with a modified tail. As described herein, a “modified tail” may be a tail with shorter or longer aliphatic chains, aliphatic chains with branching introduced, aliphatic chains with substituents introduced, aliphatic chains wherein one or more methylenes are replaced by cyclic or heteroatom groups, or any combination thereof. In some embodiments, the compound of (PL-I) is of Formula (PL-I-a), or a salt thereof, wherein at least one instance of R^2 is each instance of R^2 is optionally substituted C_{1-30} alkyl, wherein one or more methylene units of R^2 are independently replaced with optionally substituted carbocyclylene, optionally substituted heterocyclylene, optionally substituted arylene, optionally substituted heteroarylene, $-\text{N}(\text{R}^{\text{N}})-$, $-\text{O}-$, $-\text{S}-$, $-\text{C}(\text{O})-$, $-\text{C}(\text{O})\text{N}(\text{R}^{\text{N}})-$, $-\text{NR}^{\text{N}}\text{C}(\text{O})-$, $-\text{NR}^{\text{N}}\text{C}(\text{O})\text{N}(\text{R}^{\text{N}})-$, $-\text{C}(\text{O})\text{O}-$, $-\text{OC}(\text{O})-$, $-\text{OC}(\text{O})\text{O}-$, $-\text{OC}(\text{O})\text{N}(\text{R}^{\text{N}})-$, $-\text{NR}^{\text{N}}\text{C}(\text{O})\text{O}-$, $-\text{C}(\text{O})\text{S}-$, $-\text{SC}(\text{O})-$, $-\text{C}(=\text{NR}^{\text{N}})-$, $-\text{C}(=\text{NR}^{\text{N}})\text{N}(\text{R}^{\text{N}})-$, $-\text{NR}^{\text{N}}\text{C}(=\text{NR}^{\text{N}})-$, $-\text{NR}^{\text{N}}\text{C}(=\text{NR}^{\text{N}})\text{N}(\text{R}^{\text{N}})-$, $-\text{C}(\text{S})-$, $-\text{C}(\text{S})\text{N}(\text{R}^{\text{N}})-$, $-\text{NR}^{\text{N}}\text{C}(\text{S})-$, $-\text{NR}^{\text{N}}\text{C}(\text{S})\text{N}(\text{R}^{\text{N}})-$, $-\text{S}(\text{O})-$, $-\text{OS}(\text{O})-$, $-\text{S}(\text{O})\text{O}-$, $-\text{OS}(\text{O})\text{O}-$, $-\text{OS}(\text{O})_2-$, $-\text{S}(\text{O})_2\text{O}-$, $-\text{OS}(\text{O})_2\text{O}-$, $-\text{N}(\text{R}^{\text{N}})\text{S}(\text{O})-$, $-\text{S}(\text{O})\text{N}(\text{R}^{\text{N}})-$, $-\text{N}(\text{R}^{\text{N}})\text{S}(\text{O})\text{N}(\text{R}^{\text{N}})-$, $-\text{OS}(\text{O})\text{N}(\text{R}^{\text{N}})-$, $-\text{N}(\text{R}^{\text{N}})\text{S}(\text{O})\text{O}-$, $-\text{S}(\text{O})_2-$, $-\text{N}(\text{R}^{\text{N}})\text{S}(\text{O})_2-$, $-\text{S}(\text{O})_2\text{N}(\text{R}^{\text{N}})-$, $-\text{N}(\text{R}^{\text{N}})\text{S}(\text{O})_2\text{N}(\text{R}^{\text{N}})-$, $-\text{OS}(\text{O})_2\text{N}(\text{R}^{\text{N}})-$, or $-\text{N}(\text{R}^{\text{N}})\text{S}(\text{O})_2\text{O}-$.

[00375] In some embodiments, the compound of Formula (PL-I) is of Formula (PL-I-c):

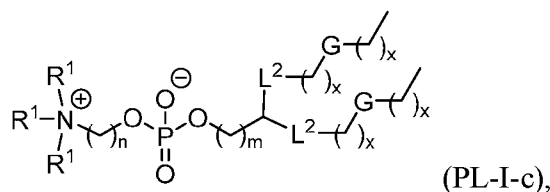

or a salt thereof, wherein:

each x is independently an integer between 0-30, inclusive; and

each instance is G is independently selected from the group consisting of optionally substituted carbocyclylene, optionally substituted heterocyclylene, optionally substituted arylene, optionally substituted heteroarylene, $-N(R^N)-$, $-O-$, $-S-$, $-C(O)-$, $-C(O)N(R^N)-$, $-NR^NC(O)-$, $-NR^NC(O)N(R^N)-$, $-C(O)O-$, $-OC(O)-$, $-OC(O)O-$, $-OC(O)N(R^N)-$, $-NR^NC(O)O-$, $-C(O)S-$, $-SC(O)-$, $-C(=NR^N)-$, $-C(=NR^N)N(R^N)-$, $-NR^NC(=NR^N)-$, $-NR^NC(=NR^N)N(R^N)-$, $-C(S)-$, $-C(S)N(R^N)-$, $-NR^NC(S)-$, $-NR^NC(S)N(R^N)-$, $-S(O)-$, $-OS(O)-$, $-S(O)O-$, $-OS(O)O-$, $-OS(O)_2-$, $-S(O)_2O-$, $-OS(O)_2O-$, $-N(R^N)S(O)-$, $-S(O)N(R^N)-$, $-N(R^N)S(O)N(R^N)-$, $-OS(O)N(R^N)-$, $-N(R^N)S(O)O-$, $-S(O)_2-$, $-N(R^N)S(O)_2-$, $-S(O)_2N(R^N)-$, $-N(R^N)S(O)_2N(R^N)-$, $-OS(O)_2N(R^N)-$, or $-N(R^N)S(O)_2O-$. Each possibility represents a separate embodiment of the present invention.

[00376] In some embodiments, a phospholipid useful or potentially useful in the present invention comprises a modified phosphocholine moiety, wherein the alkyl chain linking the quaternary amine to the phosphoryl group is not ethylene (*e.g.*, n is not 2). Therefore, in some embodiments, a phospholipid useful or potentially useful in the present invention is a compound of Formula (PL-I), wherein n is 1, 3, 4, 5, 6, 7, 8, 9, or 10. In some embodiments, a compound of Formula (PL-I) is of one of the following formulae:

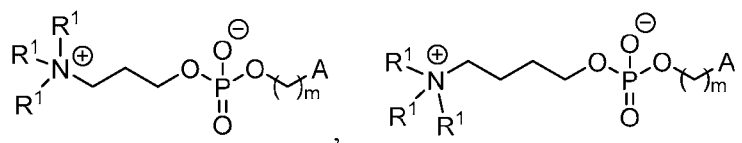

or a salt thereof.

Alternative lipids

[00377] In some embodiments, an alternative lipid is used in place of a phospholipid of the present disclosure. Non-limiting examples of such alternative lipids include the following:

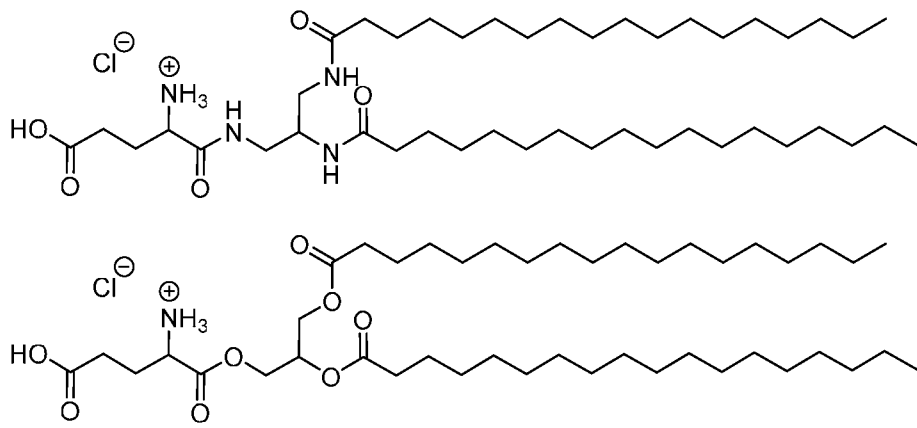

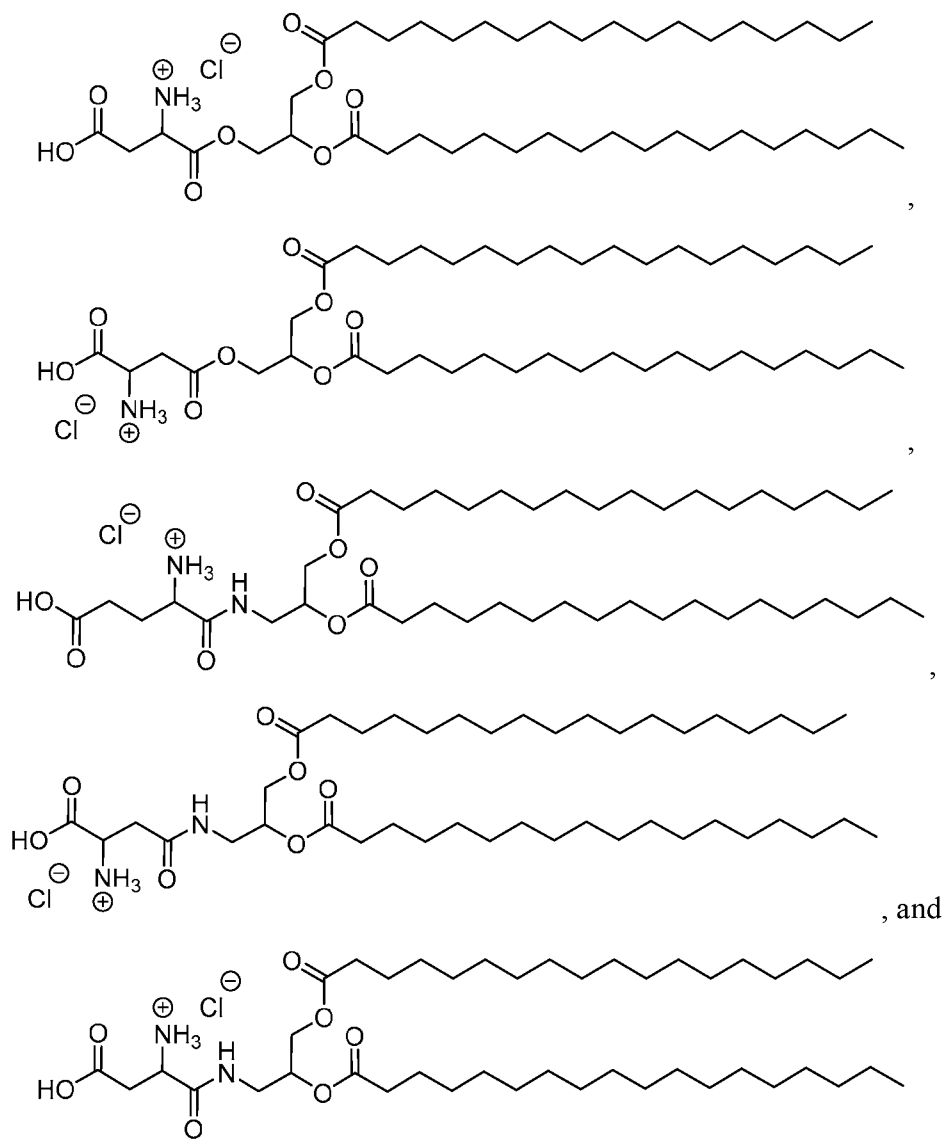

Adjuvants

[00378] In some embodiments, a LNP that includes one or more lipids described herein may further include one or more adjuvants, e.g., Glucopyranosyl Lipid Adjuvant (GLA), CpG oligodeoxynucleotides (e.g., Class A or B), poly(I:C), aluminum hydroxide, and Pam3CSK4.

Therapeutic Agents

[00379] Lipid nanoparticles may include one or more therapeutics and/or prophylactics, such as a nucleic acid. The disclosure features methods of delivering a therapeutic and/or

prophylactic, such as a nucleic acid, to a mammalian cell or organ, producing a polypeptide of interest in a mammalian cell, and treating a disease or disorder in a mammal in need thereof comprising administering to a mammal and/or contacting a mammalian cell with a LNP including a therapeutic and/or prophylactic, such as a nucleic acid.

[00380] Therapeutics and/or prophylactics include biologically active substances and are alternately referred to as “active agents”. A therapeutic and/or prophylactic may be a substance that, once delivered to a cell or organ, brings about a desirable change in the cell, organ, or other bodily tissue or system. Such species may be useful in the treatment of one or more diseases, disorders, or conditions. In some embodiments, a therapeutic and/or prophylactic is a small molecule drug useful in the treatment of a particular disease, disorder, or condition. Examples of drugs useful in the lipid nanoparticles include, but are not limited to, antineoplastic agents (*e.g.*, vincristine, doxorubicin, mitoxantrone, camptothecin, cisplatin, bleomycin, cyclophosphamide, methotrexate, and streptozotocin), antitumor agents (*e.g.*, actinomycin D, vincristine, vinblastine, cytosine arabinoside, anthracyclines, alkylating agents, platinum compounds, antimetabolites, and nucleoside analogs, such as methotrexate and purine and pyrimidine analogs), anti-infective agents, local anesthetics (*e.g.*, dibucaine and chlorpromazine), beta-adrenergic blockers (*e.g.*, propranolol, timolol, and labetalol), antihypertensive agents (*e.g.*, clonidine and hydralazine), anti-depressants (*e.g.*, imipramine, amitriptyline, and doxepin), anti-convulsants (*e.g.*, phenytoin), antihistamines (*e.g.*, diphenhydramine, chlorpheniramine, and promethazine), antibiotic/antibacterial agents (*e.g.*, gentamycin, ciprofloxacin, and cefoxitin), antifungal agents (*e.g.*, miconazole, terconazole, econazole, isoconazole, butaconazole, clotrimazole, itraconazole, nystatin, naftifine, and amphotericin B), antiparasitic agents, hormones, hormone antagonists, immunomodulators, neurotransmitter antagonists, antiglaucoma agents, vitamins, narcotics, and imaging agents.

[00381] In some embodiments, a therapeutic and/or prophylactic is a cytotoxin, a radioactive ion, a chemotherapeutic, a vaccine, a compound that elicits an immune response, and/or another therapeutic and/or prophylactic. A cytotoxin or cytotoxic agent includes any agent that may be detrimental to cells. Examples include, but are not limited to, taxol, cytochalasin B, gramicidin D, ethidium bromide, emetine, mitomycin, etoposide, teniposide, vincristine, vinblastine, colchicine, doxorubicin, daunorubicin, dihydroxyanthracenedione, mitoxantrone, mithramycin, actinomycin D, 1-dehydrotestosterone, glucocorticoids, procaine, tetracaine, lidocaine,

propranolol, puromycin, maytansinoids, *e.g.*, maytansinol, rachelmycin (CC-1065), and analogs or homologs thereof. Radioactive ions include, but are not limited to iodine (*e.g.*, iodine 125 or iodine 131), strontium 89, phosphorous, palladium, cesium, iridium, phosphate, cobalt, yttrium 90, samarium 153, and praseodymium. Vaccines include compounds and preparations that are capable of providing immunity against one or more conditions related to infectious diseases such as influenza, measles, human papillomavirus (HPV), rabies, meningitis, whooping cough, tetanus, plague, hepatitis, and tuberculosis and can include mRNAs encoding infectious disease derived antigens and/or epitopes. Vaccines also include compounds and preparations that direct an immune response against cancer cells and can include mRNAs encoding tumor cell derived antigens, epitopes, and/or neoepitopes. Compounds eliciting immune responses may include, but are not limited to, vaccines, corticosteroids (*e.g.*, dexamethasone), and other species.

[00382] In some embodiments, a therapeutic and/or prophylactic is a protein. Therapeutic proteins useful in the nanoparticles in the disclosure include, but are not limited to, gentamycin, amikacin, insulin, erythropoietin (EPO), granulocyte-colony stimulating factor (G-CSF), granulocyte-macrophage colony stimulating factor (GM-CSF), Factor VIR, luteinizing hormone-releasing hormone (LHRH) analogs, interferons, heparin, Hepatitis B surface antigen, typhoid vaccine, and cholera vaccine. In some embodiments, a vaccine and/or a compound capable of eliciting an immune response is administered intramuscularly via a composition including a compound according to Formula (IL-I), (IL-IA), (IL-IB), (IL-II), (IL-IIa), (IL-IIb), (IL-IIc), (IL-IId), (IL-IIe), (IL-IIf), (IL-IIg), (IL-III), (IL-IIIa1), (IL-IIIa2), (IL-IIIa3), (IL-IIIa4), (IL-IIIa5), (IL-IIIa6), (IL-IIIa7), or (IL-IIIa8) (*e.g.*, Compound 3, 18, 20, 26, or 29). Other therapeutics and/or prophylactics include, but are not limited to, antimetabolites (*e.g.*, methotrexate, 6-mercaptopurine, 6-thioguanine, cytarabine, 5-fluorouracil dacarbazine), alkylating agents (*e.g.*, mechlorethamine, thiotepa chlorambucil, rachelmycin (CC-1065), melphalan, carmustine (BSNU), lomustine (CCNU), cyclophosphamide, busulfan, dibromomannitol, streptozotocin, mitomycin C, and cis-dichlorodiamine platinum (II) (DDP) cisplatin), anthracyclines (*e.g.*, daunorubicin (formerly daunomycin) and doxorubicin), antibiotics (*e.g.*, dactinomycin (formerly actinomycin), bleomycin, mithramycin, and anthramycin (AMC)), and anti-mitotic agents (*e.g.*, vincristine, vinblastine, taxol and maytansinoids).

Polynucleotides and Nucleic Acids

[00383] In some embodiments, a therapeutic agent is a polynucleotide or nucleic acid (*e.g.*, ribonucleic acid or deoxyribonucleic acid). The term “polynucleotide”, in its broadest sense, includes any compound and/or substance that is or can be incorporated into an oligonucleotide chain. Exemplary polynucleotides for use in accordance with the present disclosure include, but are not limited to, one or more of deoxyribonucleic acid (DNA), ribonucleic acid (RNA) including messenger RNA (mRNA), hybrids thereof, RNAi-inducing agents, RNAi agents, siRNAs, shRNAs, miRNAs, antisense RNAs, ribozymes, catalytic DNA, RNAs that induce triple helix formation, aptamers, vectors, etc. In some embodiments, a thereapeutic and/or prophylactic is an RNA. RNAs useful in the compositions and methods described herein can be selected from the group consisting of, but are not limited to, shortmers, antagomirs, antisense, ribozymes, small interfering RNA (siRNA), asymmetrical interfering RNA (aiRNA), microRNA (miRNA), Dicer-substrate RNA (dsRNA), small hairpin RNA (shRNA), transfer RNA (tRNA), messenger RNA (mRNA), and mixtures thereof. In some embodiments, the RNA is an mRNA.

[00384] In some embodiments, a therapeutic and/or prophylactic is an mRNA. An mRNA may encode any polypeptide of interest, including any naturally or non-naturally occurring or otherwise modified polypeptide. A polypeptide encoded by an mRNA may be of any size and may have any secondary structure or activity. In some embodiments, a polypeptide encoded by an mRNA may have a therapeutic effect when expressed in a cell.

[00385] In some embodiments, a therapeutic and/or prophylactic is an siRNA. An siRNA may be capable of selectively knocking down or down regulating expression of a gene of interest. In some embodiments, an siRNA could be selected to silence a gene associated with a particular disease, disorder, or condition upon administration to a subject in need thereof of a LNP including the siRNA. An siRNA may comprise a sequence that is complementary to an mRNA sequence that encodes a gene or protein of interest. In some embodiments, the siRNA may be an immunomodulatory siRNA.

[00386] In some embodiments, a therapeutic and/or prophylactic is an shRNA or a vector or plasmid encoding the same. An shRNA may be produced inside a target cell upon delivery of an appropriate construct to the nucleus. Constructs and mechanisms relating to shRNA are well known in the relevant arts.

[00387] Nucleic acids and polynucleotides useful in the disclosure typically include a first region of linked nucleosides encoding a polypeptide of interest (*e.g.*, a coding region), a first

flanking region located at the 5'-terminus of the first region (*e.g.*, a 5'-UTR), a second flanking region located at the 3'-terminus of the first region (*e.g.*, a 3'-UTR) at least one 5'-cap region, and a 3'-stabilizing region. In some embodiments, a nucleic acid or polynucleotide further includes a poly-A region or a Kozak sequence (*e.g.*, in the 5'-UTR). In some cases, polynucleotides may contain one or more intronic nucleotide sequences capable of being excised from the polynucleotide. In some embodiments, a polynucleotide or nucleic acid (*e.g.*, an mRNA) may include a 5' cap structure, a chain terminating nucleotide, a stem loop, a polyA sequence, and/or a polyadenylation signal. Any one of the regions of a nucleic acid may include one or more alternative components (*e.g.*, an alternative nucleoside). In some embodiments, the 3'-stabilizing region may contain an alternative nucleoside such as an L-nucleoside, an inverted thymidine, or a 2'-O-methyl nucleoside and/or the coding region, 5'-UTR, 3'-UTR, or cap region may include an alternative nucleoside such as a 5-substituted uridine (*e.g.*, 5-methoxyuridine), a 1-substituted pseudouridine (*e.g.*, 1-methyl-pseudouridine), and/or a 5-substituted cytidine (*e.g.*, 5-methyl-cytidine).

[00388] Generally, the shortest length of a polynucleotide can be the length of the polynucleotide sequence that is sufficient to encode for a dipeptide. In another embodiment, the length of the polynucleotide sequence is sufficient to encode for a tripeptide. In another embodiment, the length of the polynucleotide sequence is sufficient to encode for a tetrapeptide. In another embodiment, the length of the polynucleotide sequence is sufficient to encode for a pentapeptide. In another embodiment, the length of the polynucleotide sequence is sufficient to encode for a hexapeptide. In another embodiment, the length of the polynucleotide sequence is sufficient to encode for a heptapeptide. In another embodiment, the length of the polynucleotide sequence is sufficient to encode for an octapeptide. In another embodiment, the length of the polynucleotide sequence is sufficient to encode for a nonapeptide. In another embodiment, the length of the polynucleotide sequence is sufficient to encode for a decapeptide.

[00389] Examples of dipeptides that the alternative polynucleotide sequences can encode for include, but are not limited to, carnosine and anserine.

[00390] In some cases, a polynucleotide is greater than 30 nucleotides in length. In another embodiment, the polynucleotide molecule is greater than 35 nucleotides in length. In another embodiment, the length is at least 40 nucleotides. In another embodiment, the length is at least 45 nucleotides. In another embodiment, the length is at least 50 nucleotides. In another

embodiment, the length is at least 55 nucleotides. In another embodiment, the length is at least 60 nucleotides. In another embodiment, the length is at least 80 nucleotides. In another embodiment, the length is at least 90 nucleotides. In another embodiment, the length is at least 100 nucleotides. In another embodiment, the length is at least 120 nucleotides. In another embodiment, the length is at least 140 nucleotides. In another embodiment, the length is at least 160 nucleotides. In another embodiment, the length is at least 180 nucleotides. In another embodiment, the length is at least 200 nucleotides. In another embodiment, the length is at least 250 nucleotides. In another embodiment, the length is at least 300 nucleotides. In another embodiment, the length is at least 350 nucleotides. In another embodiment, the length is at least 400 nucleotides. In another embodiment, the length is at least 450 nucleotides. In another embodiment, the length is at least 500 nucleotides. In another embodiment, the length is at least 600 nucleotides. In another embodiment, the length is at least 700 nucleotides. In another embodiment, the length is at least 800 nucleotides. In another embodiment, the length is at least 900 nucleotides. In another embodiment, the length is at least 1000 nucleotides. In another embodiment, the length is at least 1100 nucleotides. In another embodiment, the length is at least 1200 nucleotides. In another embodiment, the length is at least 1300 nucleotides. In another embodiment, the length is at least 1400 nucleotides. In another embodiment, the length is at least 1500 nucleotides. In another embodiment, the length is at least 1600 nucleotides. In another embodiment, the length is at least 1800 nucleotides. In another embodiment, the length is at least 2000 nucleotides. In another embodiment, the length is at least 2500 nucleotides. In another embodiment, the length is at least 3000 nucleotides. In another embodiment, the length is at least 4000 nucleotides. In another embodiment, the length is at least 5000 nucleotides, or greater than 5000 nucleotides.

[00391] Nucleic acids and polynucleotides may include one or more naturally occurring components, including any of the canonical nucleotides A (adenosine), G (guanosine), C (cytosine), U (uridine), or T (thymidine). In some embodiments, all or substantially all of the nucleotides comprising (a) the 5'-UTR, (b) the open reading frame (ORF), (c) the 3'-UTR, (d) the poly A tail, and any combination of (a, b, c, or d above) comprise naturally occurring canonical nucleotides A (adenosine), G (guanosine), C (cytosine), U (uridine), or T (thymidine).

[00392] Nucleic acids and polynucleotides may include one or more alternative components, as described herein, which impart useful properties including increased stability and/or the lack

of a substantial induction of the innate immune response of a cell into which the polynucleotide is introduced. In some embodiments, an alternative polynucleotide or nucleic acid exhibits reduced degradation in a cell into which the polynucleotide or nucleic acid is introduced, relative to a corresponding unaltered polynucleotide or nucleic acid. These alternative species may enhance the efficiency of protein production, intracellular retention of the polynucleotides, and/or viability of contacted cells, as well as possess reduced immunogenicity.

[00393] Polynucleotides and nucleic acids may be naturally or non-naturally occurring. Polynucleotides and nucleic acids may include one or more modified (*e.g.*, altered or alternative) nucleobases, nucleosides, nucleotides, or combinations thereof. The nucleic acids and polynucleotides useful in a LNP can include any useful modification or alteration, such as to the nucleobase, the sugar, or the internucleoside linkage (*e.g.*, to a linking phosphate, to a phosphodiester linkage, to the phosphodiester backbone). In some embodiments, alterations (*e.g.*, one or more alterations) are present in each of the nucleobase, the sugar, and the internucleoside linkage. Alterations according to the present disclosure may be alterations of ribonucleic acids (RNAs) to deoxyribonucleic acids (DNAs), *e.g.*, the substitution of the 2'-OH of the ribofuranosyl ring to 2'-H, threose nucleic acids (TNAs), glycol nucleic acids (GNAs), peptide nucleic acids (PNAs), locked nucleic acids (LNAs), or hybrids thereof. Additional alterations are described herein.

[00394] Polynucleotides and nucleic acids may or may not be uniformly altered along the entire length of the molecule. In some embodiments, one or more or all types of nucleotide (*e.g.*, purine or pyrimidine, or any one or more or all of A, G, U, C) may or may not be uniformly altered in a polynucleotide or nucleic acid, or in a given predetermined sequence region thereof. In some instances, all nucleotides X in a polynucleotide (or in a given sequence region thereof) are altered, wherein X may be any one of nucleotides A, G, U, C, or any one of the combinations A+G, A+U, A+C, G+U, G+C, U+C, A+G+U, A+G+C, G+U+C, or A+G+U+C.

[00395] Different sugar alterations and/or internucleoside linkages (*e.g.*, backbone structures) may exist at various positions in a polynucleotide. One of ordinary skill in the art will appreciate that the nucleotide analogs or other alteration(s) may be located at any position(s) of a polynucleotide such that the function of the polynucleotide is not substantially decreased. An alteration may also be a 5'- or 3'-terminal alteration. In some embodiments, the polynucleotide includes an alteration at the 3'-terminus. The polynucleotide may contain from about 1% to

about 100% alternative nucleotides (either in relation to overall nucleotide content, or in relation to one or more types of nucleotide, i.e., any one or more of A, G, U, or C) or any intervening percentage (*e.g.*, from 1% to 20%, from 1% to 25%, from 1% to 50%, from 1% to 60%, from 1% to 70%, from 1% to 80%, from 1% to 90%, from 1% to 95%, from 10% to 20%, from 10% to 25%, from 10% to 50%, from 10% to 60%, from 10% to 70%, from 10% to 80%, from 10% to 90%, from 10% to 95%, from 10% to 100%, from 20% to 25%, from 20% to 50%, from 20% to 60%, from 20% to 70%, from 20% to 80%, from 20% to 90%, from 20% to 95%, from 20% to 100%, from 50% to 60%, from 50% to 70%, from 50% to 80%, from 50% to 90%, from 50% to 95%, from 50% to 100%, from 70% to 80%, from 70% to 90%, from 70% to 95%, from 70% to 100%, from 80% to 90%, from 80% to 95%, from 80% to 100% from 90% to 95%, from 90% to 100%, and from 95% to 100%). It will be understood that any remaining percentage is accounted for by the presence of a canonical nucleotide (*e.g.*, A, G, U, or C).

[00396] Polynucleotides may contain at a minimum zero and at a maximum 100% alternative nucleotides, or any intervening percentages, such as at least 5% alternative nucleotides, at least 10% alternative nucleotides, at least 25% alternative nucleotides, at least 50% alternative nucleotides, at least 80% alternative nucleotides, or at least 90% alternative nucleotides. In some embodiments, polynucleotides may contain an alternative pyrimidine such as an alternative uracil or cytosine. In some embodiments, at least 5%, at least 10%, at least 25%, at least 50%, at least 80%, at least 90% or 100% of the uracil in a polynucleotide is replaced with an alternative uracil (*e.g.*, a 5-substituted uracil). The alternative uracil can be replaced by a compound having a single unique structure, or can be replaced by a plurality of compounds having different structures (*e.g.*, 2, 3, 4 or more unique structures). In some instances, at least 5%, at least 10%, at least 25%, at least 50%, at least 80%, at least 90% or 100% of the cytosine in the polynucleotide is replaced with an alternative cytosine (*e.g.*, a 5-substituted cytosine). The alternative cytosine can be replaced by a compound having a single unique structure, or can be replaced by a plurality of compounds having different structures (*e.g.*, 2, 3, 4 or more unique structures).

[00397] In some embodiments, nucleic acids do not substantially induce an innate immune response of a cell into which the polynucleotide (*e.g.*, mRNA) is introduced. Features of an induced innate immune response include 1) increased expression of pro-inflammatory cytokines,

2) activation of intracellular PRRs (RIG-I, MDA5, etc.), and/or 3) termination or reduction in protein translation.

[00398] The nucleic acids can optionally include other agents (*e.g.*, RNAi-inducing agents, RNAi agents, siRNAs, shRNAs, miRNAs, antisense RNAs, ribozymes, catalytic DNA, tRNA, RNAs that induce triple helix formation, aptamers, vectors). In some embodiments, the nucleic acids may include one or more messenger RNAs (mRNAs) having one or more alternative nucleoside or nucleotides (*i.e.*, alternative mRNA molecules).

[00399] In some embodiments, a nucleic acid (*e.g.*, mRNA) molecule, formula, composition or method associated therewith comprises one or more polynucleotides comprising features as described in WO2002/098443, WO2003/051401, WO2008/052770, WO2009127230, WO2006122828, WO2008/083949, WO2010088927, WO2010/037539, WO2004/004743, WO2005/016376, WO2006/024518, WO2007/095976, WO2008/014979, WO2008/077592, WO2009/030481, WO2009/095226, WO2011069586, WO2011026641, WO2011/144358, WO2012019780, WO2012013326, WO2012089338, WO2012113513, WO2012116811, WO2012116810, WO2013113502, WO2013113501, WO2013113736, WO2013143698, WO2013143699, WO2013143700, WO2013/120626, WO2013120627, WO2013120628, WO2013120629, WO2013174409, WO2014127917, WO2015/024669, WO2015/024668, WO2015/024667, WO2015/024665, WO2015/024666, WO2015/024664, WO2015101415, WO2015101414, WO2015024667, WO2015062738, WO2015101416, all of which are incorporated by reference herein.

Nucleobase Alternatives

[00400] The alternative nucleosides and nucleotides can include an alternative nucleobase. A nucleobase of a nucleic acid is an organic base such as a purine or pyrimidine or a derivative thereof. A nucleobase may be a canonical base (*e.g.*, adenine, guanine, uracil, thymine, and cytosine). These nucleobases can be altered or wholly replaced to provide polynucleotide molecules having enhanced properties, *e.g.*, increased stability such as resistance to nucleases. Non-canonical or modified bases may include, for example, one or more substitutions or modifications including, but not limited to, alkyl, aryl, halo, oxo, hydroxyl, alkyloxy, and/or thio substitutions; one or more fused or open rings; oxidation; and/or reduction.

[00401] Alternative nucleotide base pairing encompasses not only the standard adenine-thymine, adenine-uracil, or guanine-cytosine base pairs, but also base pairs formed between nucleotides and/or alternative nucleotides including non-standard or alternative bases, wherein the arrangement of hydrogen bond donors and hydrogen bond acceptors permits hydrogen bonding between a non-standard base and a standard base or between two complementary non-standard base structures. One example of such non-standard base pairing is the base pairing between the alternative nucleotide inosine and adenine, cytosine, or uracil.

[00402] In some embodiments, the nucleobase is an alternative uracil. Exemplary nucleobases and nucleosides having an alternative uracil include, but are not limited to, pseudouridine (ψ), pyridin-4-one ribonucleoside, 5-aza-uracil, 6-aza-uracil, 2-thio-5-aza-uracil, 2-thio-uracil (s^2U), 4-thio-uracil (s^4U), 4-thio-pseudouridine, 2-thio-pseudouridine, 5-hydroxy-uracil (ho^5U), 5-aminoallyl-uracil, 5-halo-uracil (*e.g.*, 5-iodo-uracil or 5-bromo-uracil), 3-methyl-uracil (m^3U), 5-methoxy-uracil (mo^5U), uracil 5-oxyacetic acid (cmo^5U), uracil 5-oxyacetic acid methyl ester ($mcmo^5U$), 5-carboxymethyl-uracil (cm^5U), 1-carboxymethyl-pseudouridine, 5-carboxyhydroxymethyl-uracil (chm^5U), 5-carboxyhydroxymethyl-uracil methyl ester ($mchm^5U$), 5-methoxycarbonylmethyl-uracil (mcm^5U), 5-methoxycarbonylmethyl-2-thio-uracil (mcm^5s^2U), 5-aminomethyl-2-thio-uracil (nm^5s^2U), 5-methylaminomethyl-uracil (mm^5U), 5-methylaminomethyl-2-thio-uracil (mm^5s^2U), 5-methylaminomethyl-2-seleno-uracil (mm^5se^2U), 5-carbamoylmethyl-uracil (ncm^5U), 5-carboxymethylaminomethyl-uracil ($cmnm^5U$), 5-carboxymethylaminomethyl-2-thio-uracil ($cmnm^5s^2U$), 5-propynyl-uracil, 1-propynyl-pseudouracil, 5-taurinomethyl-uracil (τm^5U), 1-taurinomethyl-pseudouridine, 5-taurinomethyl-2-thio-uracil (τm^5s^2U), 1-taurinomethyl-4-thio-pseudouridine, 5-methyl-uracil (m^5U , *i.e.*, having the nucleobase deoxythymine), 1-methyl-pseudouridine ($m^1\psi$), 5-methyl-2-thio-uracil (m^5s^2U), 1-methyl-4-thio-pseudouridine ($m^1s^4\psi$), 4-thio-1-methyl-pseudouridine, 3-methyl-pseudouridine ($m^3\psi$), 2-thio-1-methyl-pseudouridine, 1-methyl-1-deaza-pseudouridine, 2-thio-1-methyl-1-deaza-pseudouridine, dihydrouracil (D), dihydropseudouridine, 5,6-dihydrouracil, 5-methyl-dihydrouracil (m^5D), 2-thio-dihydrouracil, 2-thio-dihydropseudouridine, 2-methoxy-uracil, 2-methoxy-4-thio-uracil, 4-methoxy-pseudouridine, 4-methoxy-2-thio-pseudouridine, N1-methyl-pseudouridine, 3-(3-amino-3-carboxypropyl)uracil (acp^3U), 1-methyl-3-(3-amino-3-carboxypropyl)pseudouridine ($acp^3\psi$), 5-(isopentenylaminomethyl)uracil (inm^5U), 5-(isopentenylaminomethyl)-2-thio-uracil (inm^5s^2U), 5,2'-O-dimethyl-uridine (m^5Um),

2-thio-2'-O-methyl-uridine (s^2Um), 5-methoxycarbonylmethyl-2'-O-methyl-uridine (mcm^5Um), 5-carbamoylmethyl-2'-O-methyl-uridine (ncm^5Um), 5-carboxymethylaminomethyl-2'-O-methyl-uridine ($cmnm^5Um$), 3,2'-O-dimethyl-uridine (m^3Um), and 5-(isopentenylaminomethyl)-2'-O-methyl-uridine (inm^5Um), 1-thio-uracil, deoxythymidine, 5-(2-carbomethoxyvinyl)-uracil, 5-(carbamoylhydroxymethyl)-uracil, 5-carbamoylmethyl-2-thio-uracil, 5-carboxymethyl-2-thio-uracil, 5-cyanomethyl-uracil, 5-methoxy-2-thio-uracil, and 5-[3-(1-E-propenylamino)]uracil.

[00403] In some embodiments, the nucleobase is an alternative cytosine. Exemplary nucleobases and nucleosides having an alternative cytosine include, but are not limited to, 5-aza-cytosine, 6-aza-cytosine, pseudoisocytidine, 3-methyl-cytosine ($m3C$), N4-acetyl-cytosine ($ac4C$), 5-formyl-cytosine ($f5C$), N4-methyl-cytosine ($m4C$), 5-methyl-cytosine ($m5C$), 5-halo-cytosine (*e.g.*, 5-iodo-cytosine), 5-hydroxymethyl-cytosine ($hm5C$), 1-methyl-pseudoisocytidine, pyrrolo-cytosine, pyrrolo-pseudoisocytidine, 2-thio-cytosine ($s2C$), 2-thio-5-methyl-cytosine, 4-thio-pseudoisocytidine, 4-thio-1-methyl-pseudoisocytidine, 4-thio-1-methyl-1-deaza-pseudoisocytidine, 1-methyl-1-deaza-pseudoisocytidine, zebularine, 5-aza-zebularine, 5-methyl-zebularine, 5-aza-2-thio-zebularine, 2-thio-zebularine, 2-methoxy-cytosine, 2-methoxy-5-methyl-cytosine, 4-methoxy-pseudoisocytidine, 4-methoxy-1-methyl-pseudoisocytidine, lysidine ($k2C$), 5,2'-O-dimethyl-cytidine ($m5Cm$), N4-acetyl-2'-O-methyl-cytidine ($ac4Cm$), N4,2'-O-dimethyl-cytidine ($m4Cm$), 5-formyl-2'-O-methyl-cytidine ($f5Cm$), N4,N4,2'-O-trimethyl-cytidine ($m42Cm$), 1-thio-cytosine, 5-hydroxy-cytosine, 5-(3-azidopropyl)-cytosine, and 5-(2-azidoethyl)-cytosine.

[00404] In some embodiments, the nucleobase is an alternative adenine. Exemplary nucleobases and nucleosides having an alternative adenine include, but are not limited to, 2-amino-purine, 2,6-diaminopurine, 2-amino-6-halo-purine (*e.g.*, 2-amino-6-chloro-purine), 6-halo-purine (*e.g.*, 6-chloro-purine), 2-amino-6-methyl-purine, 8-azido-adenine, 7-deaza-adenine, 7-deaza-8-aza-adenine, 7-deaza-2-amino-purine, 7-deaza-8-aza-2-amino-purine, 7-deaza-2,6-diaminopurine, 7-deaza-8-aza-2,6-diaminopurine, 1-methyl-adenine ($m1A$), 2-methyl-adenine ($m2A$), N6-methyl-adenine ($m6A$), 2-methylthio-N6-methyl-adenine ($ms2m6A$), N6-isopentenyl-adenine ($i6A$), 2-methylthio-N6-isopentenyl-adenine ($ms2i6A$), N6-(cis-hydroxyisopentenyl)adenine ($io6A$), 2-methylthio-N6-(cis-hydroxyisopentenyl)adenine ($ms2io6A$), N6-glycylcarbonyl-adenine ($g6A$), N6-threonylcarbonyl-adenine ($t6A$), N6-methyl-N6-threonylcarbonyl-adenine ($m6t6A$), 2-methylthio-N6-threonylcarbonyl-adenine

(ms2g6A), N6,N6-dimethyl-adenine (m62A), N6-hydroxynorvalylcarbamoyl-adenine (hn6A), 2-methylthio-N6-hydroxynorvalylcarbamoyl-adenine (ms2hn6A), N6-acetyl-adenine (ac6A), 7-methyl-adenine, 2-methylthio-adenine, 2-methoxy-adenine, N6,2'-O-dimethyl-adenosine (m6Am), N6,N6,2'-O-trimethyl-adenosine (m62Am), 1,2'-O-dimethyl-adenosine (m1Am), 2-amino-N6-methyl-purine, 1-thio-adenine, 8-azido-adenine, N6-(19-amino-pentaoxonadecyl)-adenine, 2,8-dimethyl-adenine, N6-formyl-adenine, and N6-hydroxymethyl-adenine.

[00405] In some embodiments, the nucleobase is an alternative guanine. Exemplary nucleobases and nucleosides having an alternative guanine include, but are not limited to, inosine (I), 1-methyl-inosine (m1I), wyosine (imG), methylwyosine (mimG), 4-demethyl-wyosine (imG-14), isowyosine (imG2), wybutosine (yW), peroxywybutosine (o2yW), hydroxywybutosine (OHyW), undermodified hydroxywybutosine (OHyW*), 7-deaza-guanine, queuosine (Q), epoxyqueuosine (oQ), galactosyl-queuosine (galQ), mannosyl-queuosine (manQ), 7-cyano-7-deaza-guanine (preQ0), 7-aminomethyl-7-deaza-guanine (preQ1), archaeosine (G+), 7-deaza-8-aza-guanine, 6-thio-guanine, 6-thio-7-deaza-guanine, 6-thio-7-deaza-8-aza-guanine, 7-methyl-guanine (m7G), 6-thio-7-methyl-guanine, 7-methyl-inosine, 6-methoxy-guanine, 1-methyl-guanine (m1G), N2-methyl-guanine (m2G), N2,N2-dimethyl-guanine (m22G), N2,7-dimethyl-guanine (m2,7G), N2, N2,7-dimethyl-guanine (m2,2,7G), 8-oxo-guanine, 7-methyl-8-oxo-guanine, 1-methyl-6-thio-guanine, N2-methyl-6-thio-guanine, N2,N2-dimethyl-6-thio-guanine, N2-methyl-2'-O-methyl-guanosine (m2Gm), N2,N2-dimethyl-2'-O-methyl-guanosine (m22Gm), 1-methyl-2'-O-methyl-guanosine (m1Gm), N2,7-dimethyl-2'-O-methyl-guanosine (m2,7Gm), 2'-O-methyl-inosine (Im), 1,2'-O-dimethyl-inosine (m1Im), 1-thio-guanine, and O-6-methyl-guanine.

[00406] The alternative nucleobase of a nucleotide can be independently a purine, a pyrimidine, a purine or pyrimidine analog. In some embodiments, the nucleobase can be an alternative to adenine, cytosine, guanine, uracil, or hypoxanthine. In another embodiment, the nucleobase can also include, for example, naturally-occurring and synthetic derivatives of a base, including, but not limited to, pyrazolo[3,4-d]pyrimidines, 5-methylcytosine (5-me-C), 5-hydroxymethyl cytosine, xanthine, hypoxanthine, 2-aminoadenine, 6-methyl and other alkyl derivatives of adenine and guanine, 2-propyl and other alkyl derivatives of adenine and guanine, 2-thiouracil, 2-thiothymine and 2-thiocytosine, 5-propynyl uracil and cytosine, 6-azo uracil, cytosine and thymine, 5-uracil (pseudouracil), 4-thiouracil, 8-halo (*e.g.*, 8-bromo), 8-amino, 8-

thiol, 8-thioalkyl, 8-hydroxy and other 8-substituted adenines and guanines, 5-halo particularly 5-bromo, 5-trifluoromethyl and other 5-substituted uracils and cytosines, 7-methylguanine and 7-methyladenine, 8-azaguanine and 8-azaadenine, deazaguanine, 7-deazaguanine, 3-deazaguanine, deazaadenine, 7-deazaadenine, 3-deazaadenine, pyrazolo[3,4-d]pyrimidine, imidazo[1,5-a]1,3,5 triazinones, 9-deazapurines, imidazo[4,5-d]pyrazines, thiazolo[4,5-d]pyrimidines, pyrazin-2-ones, 1,2,4-triazine, pyridazine; or 1,3,5 triazine. When the nucleotides are depicted using the shorthand A, G, C, T or U, each letter refers to the representative base and/or derivatives thereof, *e.g.*, A includes adenine or adenine analogs, *e.g.*, 7-deaza adenine).

Alterations on the Sugar

[00407] Nucleosides include a sugar molecule (*e.g.*, a 5-carbon or 6-carbon sugar, such as pentose, ribose, arabinose, xylose, glucose, galactose, or a deoxy derivative thereof) in combination with a nucleobase, while nucleotides are nucleosides containing a nucleoside and a phosphate group or alternative group (*e.g.*, boranophosphate, thiophosphate, selenophosphate, phosphonate, alkyl group, amidate, and glycerol). A nucleoside or nucleotide may be a canonical species, *e.g.*, a nucleoside or nucleotide including a canonical nucleobase, sugar, and, in the case of nucleotides, a phosphate group, or may be an alternative nucleoside or nucleotide including one or more alternative components. In some embodiments, alternative nucleosides and nucleotides can be altered on the sugar of the nucleoside or nucleotide. In some embodiments, the alternative nucleosides or nucleotides include the structure:

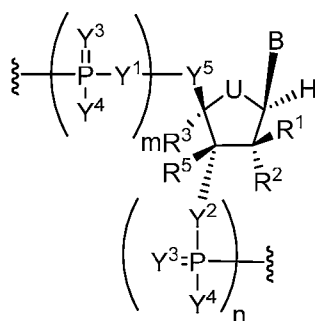

Formula IV,

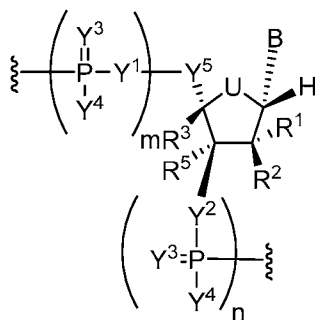

Formula V,

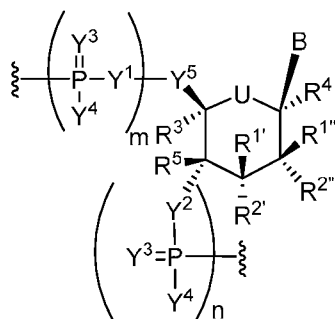

Formula VI, or

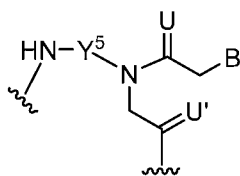

Formula VII.

In each of the Formulae IV, V, VI and VII,

each of m and n is independently, an integer from 0 to 5,

each of U and U' independently, is O, S, $N(R^U)_{nu}$, or $C(R^U)_{nu}$, wherein nu is an integer from 0 to 2 and each R^U is, independently, H, halo, or optionally substituted alkyl;

each of $R^{1'}$, $R^{2'}$, $R^{1''}$, $R^{2''}$, R^1 , R^2 , R^3 , R^4 , and R^5 is, independently, if present, H, halo, hydroxy, thiol, optionally substituted alkyl, optionally substituted alkoxy, optionally substituted alkenyloxy, optionally substituted alkynyloxy, optionally substituted aminoalkoxy, optionally substituted alkoxyalkoxy, optionally substituted hydroxyalkoxy, optionally substituted amino, azido, optionally substituted aryl, optionally substituted aminoalkyl, optionally substituted aminoalkenyl, optionally substituted aminoalkynyl, or absent; wherein the combination of R^3 with one or more of $R^{1'}$, $R^{1''}$, $R^{2'}$, $R^{2''}$, or R^5 (e.g., the combination of $R^{1'}$ and R^3 , the combination of $R^{1''}$ and R^3 , the combination of $R^{2'}$ and R^3 , the combination of $R^{2''}$ and R^3 , or the combination of R^5 and R^3) can join together to form optionally substituted alkylene or optionally substituted heteroalkylene and, taken together with the carbons to which they are attached, provide an optionally substituted heterocyclyl (e.g., a bicyclic, tricyclic, or tetracyclic heterocyclyl);

wherein the combination of R⁵ with one or more of R^{1'}, R^{1''}, R^{2'}, or R^{2''} (e.g., the combination of R^{1'} and R⁵, the combination of R^{1''} and R⁵, the combination of R^{2'} and R⁵, or the combination of R^{2''} and R⁵) can join together to form optionally substituted alkylene or optionally substituted heteroalkylene and, taken together with the carbons to which they are attached, provide an optionally substituted heterocyclyl (e.g., a bicyclic, tricyclic, or tetracyclic heterocyclyl); and wherein the combination of R⁴ and one or more of R^{1'}, R^{1''}, R^{2'}, R^{2''}, R³, or R⁵ can join together to form optionally substituted alkylene or optionally substituted heteroalkylene and, taken together with the carbons to which they are attached, provide an optionally substituted heterocyclyl (e.g., a bicyclic, tricyclic, or tetracyclic heterocyclyl); each of m' and m'' is, independently, an integer from 0 to 3 (e.g., from 0 to 2, from 0 to 1, from 1 to 3, or from 1 to 2);

each of Y¹, Y², and Y³, is, independently, O, S, Se, —NR^{N1}—, optionally substituted alkylene, or optionally substituted heteroalkylene, wherein R^{N1} is H, optionally substituted alkyl, optionally substituted alkenyl, optionally substituted alkynyl, optionally substituted aryl, or absent;

each Y⁴ is, independently, H, hydroxy, thiol, boranyl, optionally substituted alkyl, optionally substituted alkenyl, optionally substituted alkynyl, optionally substituted alkoxy, optionally substituted alkenyloxy, optionally substituted alkynyloxy, optionally substituted thioalkoxy, optionally substituted alkoxyalkoxy, or optionally substituted amino;

each Y⁵ is, independently, O, S, Se, optionally substituted alkylene (e.g., methylene), or optionally substituted heteroalkylene; and

B is a nucleobase, either modified or unmodified.

[00408] In some embodiments, the 2'-hydroxy group (OH) can be modified or replaced with a number of different substituents. Exemplary substitutions at the 2'-position include, but are not limited to, H, azido, halo (e.g., fluoro), optionally substituted C₁₋₆ alkyl (e.g., methyl); optionally substituted C₁₋₆ alkoxy (e.g., methoxy or ethoxy); optionally substituted C₆₋₁₀ aryloxy; optionally substituted C₃₋₈ cycloalkyl; optionally substituted C₆₋₁₀ aryl-C₁₋₆ alkoxy, optionally substituted C₁₋₁₂ (heterocyclyl)oxy; a sugar (e.g., ribose, pentose, or any described herein); a polyethyleneglycol (PEG), -O(CH₂CH₂O)_nCH₂CH₂OR, where R is H or optionally substituted alkyl, and n is an integer from 0 to 20 (e.g., from 0 to 4, from 0 to 8, from 0 to 10, from 0 to 16, from 1 to 4, from 1 to 8, from 1 to 10, from 1 to 16, from 1 to 20, from 2 to 4, from 2 to 8, from 2 to 10, from 2 to 16, from 2 to 20, from 4 to 8, from 4 to 10, from 4 to 16, and from 4 to 20);

“locked” nucleic acids (LNA) in which the 2'-hydroxy is connected by a C₁₋₆ alkylene or C₁₋₆ heteroalkylene bridge to the 4'-carbon of the same ribose sugar, where exemplary bridges included methylene, propylene, ether, or amino bridges; aminoalkyl, as defined herein; aminoalkoxy, as defined herein; amino as defined herein; and amino acid, as defined herein.

[00409] Generally, RNA includes the sugar group ribose, which is a 5-membered ring having an oxygen. Exemplary, non-limiting alternative nucleotides include replacement of the oxygen in ribose (*e.g.*, with S, Se, or alkylene, such as methylene or ethylene); addition of a double bond (*e.g.*, to replace ribose with cyclopentenyl or cyclohexenyl); ring contraction of ribose (*e.g.*, to form a 4-membered ring of cyclobutane or oxetane); ring expansion of ribose (*e.g.*, to form a 6- or 7-membered ring having an additional carbon or heteroatom, such as for anhydrohexitol, altritol, mannitol, cyclohexanyl, cyclohexenyl, and morpholino (that also has a phosphoramidate backbone)); multicyclic forms (*e.g.*, tricyclo and “unlocked” forms, such as glycol nucleic acid (GNA) (*e.g.*, R-GNA or S-GNA, where ribose is replaced by glycol units attached to phosphodiester bonds), threose nucleic acid (TNA, where ribose is replaced with α -L-threofuranosyl-(3'→2')), and peptide nucleic acid (PNA, where 2-amino-ethyl-glycine linkages replace the ribose and phosphodiester backbone).

[00410] In some embodiments, the sugar group contains one or more carbons that possess the opposite stereochemical configuration of the corresponding carbon in ribose. Thus, a polynucleotide molecule can include nucleotides containing, *e.g.*, arabinose or L-ribose, as the sugar.

[00411] In some embodiments, the polynucleotide includes at least one nucleoside wherein the sugar is L-ribose, 2'-O-methyl-ribose, 2'-fluoro-ribose, arabinose, hexitol, an LNA, or a PNA.

Alterations on the Internucleoside Linkage

[00412] Alternative nucleotides can be altered on the internucleoside linkage (*e.g.*, phosphate backbone). Herein, in the context of the polynucleotide backbone, the phrases “phosphate” and “phosphodiester” are used interchangeably. Backbone phosphate groups can be altered by replacing one or more of the oxygen atoms with a different substituent.

[00413] The alternative nucleotides can include the wholesale replacement of an unaltered phosphate moiety with another internucleoside linkage as described herein. Examples of

alternative phosphate groups include, but are not limited to, phosphorothioate, phosphoroselenates, boranophosphates, boranophosphate esters, hydrogen phosphonates, phosphoramidates, phosphorodiamidates, alkyl or aryl phosphonates, and phosphotriesters. Phosphorodithioates have both non-linking oxygens replaced by sulfur. The phosphate linker can also be altered by the replacement of a linking oxygen with nitrogen (bridged phosphoramidates), sulfur (bridged phosphorothioates), and carbon (bridged methylene-phosphonates).

[00414] The alternative nucleosides and nucleotides can include the replacement of one or more of the non-bridging oxygens with a borane moiety (BH₃), sulfur (thio), methyl, ethyl, and/or methoxy. As a non-limiting example, two non-bridging oxygens at the same position (*e.g.*, the alpha (α), beta (β) or gamma (γ) position) can be replaced with a sulfur (thio) and a methoxy.

[00415] The replacement of one or more of the oxygen atoms at the α position of the phosphate moiety (*e.g.*, α -thio phosphate) is provided to confer stability (such as against exonucleases and endonucleases) to RNA and DNA through the unnatural phosphorothioate backbone linkages. Phosphorothioate DNA and RNA have increased nuclease resistance and subsequently a longer half-life in a cellular environment.

[00416] Other internucleoside linkages that may be employed according to the present disclosure, including internucleoside linkages which do not contain a phosphorous atom, are described herein.

Internal Ribosome Entry Sites

[00417] Polynucleotides may contain an internal ribosome entry site (IRES). An IRES may act as the sole ribosome binding site, or may serve as one of multiple ribosome binding sites of an mRNA. A polynucleotide containing more than one functional ribosome binding site may encode several peptides or polypeptides that are translated independently by the ribosomes (*e.g.*, multicistronic mRNA). When polynucleotides are provided with an IRES, further optionally provided is a second translatable region. Examples of IRES sequences that can be used according to the present disclosure include without limitation, those from picornaviruses (*e.g.*, FMDV), pest viruses (CFFV), polio viruses (PV), encephalomyocarditis viruses (ECMV), foot-and-mouth disease viruses (FMDV), hepatitis C viruses (HCV), classical swine fever viruses

(CSFV), murine leukemia virus (MLV), simian immune deficiency viruses (SIV) or cricket paralysis viruses (CrPV).

5'-Cap Structure

[00418] A polynucleotide (*e.g.*, an mRNA) may include a 5'-cap structure. The 5'-cap structure of a polynucleotide is involved in nuclear export and increasing polynucleotide stability and binds the mRNA Cap Binding Protein (CBP), which is responsible for polynucleotide stability in the cell and translation competency through the association of CBP with poly-A binding protein to form the mature cyclic mRNA species. The cap further assists the removal of 5'-proximal introns removal during mRNA splicing.

[00419] Endogenous polynucleotide molecules may be 5'-end capped generating a 5'-ppp-5'-triphosphate linkage between a terminal guanosine cap residue and the 5'-terminal transcribed sense nucleotide of the polynucleotide. This 5'-guanylate cap may then be methylated to generate an N7-methyl-guanylate residue. The ribose sugars of the terminal and/or anteterminal transcribed nucleotides of the 5' end of the polynucleotide may optionally also be 2'-O-methylated. 5'-decapping through hydrolysis and cleavage of the guanylate cap structure may target a polynucleotide molecule, such as an mRNA molecule, for degradation.

[00420] Alterations to polynucleotides may generate a non-hydrolyzable cap structure preventing decapping and thus increasing polynucleotide half-life. Because cap structure hydrolysis requires cleavage of 5'-ppp-5' phosphodiester linkages, alternative nucleotides may be used during the capping reaction. In some embodiments, a Vaccinia Capping Enzyme from New England Biolabs (Ipswich, MA) may be used with α -thio-guanosine nucleotides according to the manufacturer's instructions to create a phosphorothioate linkage in the 5'-ppp-5' cap. Additional alternative guanosine nucleotides may be used such as α -methyl-phosphonate and seleno-phosphate nucleotides.

[00421] Additional alterations include, but are not limited to, 2'-O-methylation of the ribose sugars of 5'-terminal and/or 5'-anteterminal nucleotides of the polynucleotide (as mentioned above) on the 2'-hydroxy group of the sugar. Multiple distinct 5'-cap structures can be used to generate the 5'-cap of a polynucleotide, such as an mRNA molecule.

[00422] 5'-Cap structures include those described in International Patent Publication Nos. WO2008127688, WO 2008016473, and WO 2011015347, the cap structures of each of which are incorporated herein by reference.

[00423] Cap analogs, which herein are also referred to as synthetic cap analogs, chemical caps, chemical cap analogs, or structural or functional cap analogs, differ from natural (i.e., endogenous, wild-type, or physiological) 5'-caps in their chemical structure, while retaining cap function. Cap analogs may be chemically (i.e., non-enzymatically) or enzymatically synthesized and/linked to a polynucleotide.

[00424] For example, the Anti-Reverse Cap Analog (ARCA) cap contains two guanosines linked by a 5'-5'-triphosphate group, wherein one guanosine contains an N7-methyl group as well as a 3'-O-methyl group (i.e., N7,3'-O-dimethyl-guanosine-5'-triphosphate-5'-guanosine, m⁷G-3'mppp-G, which may equivalently be designated 3' O-Me-m⁷G(5')ppp(5')G). The 3'-O atom of the other, unaltered, guanosine becomes linked to the 5'-terminal nucleotide of the capped polynucleotide (e.g., an mRNA). The N7- and 3'-O-methylated guanosine provides the terminal moiety of the capped polynucleotide (e.g., mRNA).

[00425] Another exemplary cap is mCAP, which is similar to ARCA but has a 2'-O-methyl group on guanosine (i.e., N7,2'-O-dimethyl-guanosine-5'-triphosphate-5'-guanosine, m⁷Gm-ppp-G).

[00426] A cap may be a dinucleotide cap analog. As a non-limiting example, the dinucleotide cap analog may be modified at different phosphate positions with a boranophosphate group or a phosphoroselenoate group such as the dinucleotide cap analogs described in US Patent No. 8,519,110, the cap structures of which are herein incorporated by reference.

[00427] Alternatively, a cap analog may be a N7-(4-chlorophenoxyethyl) substituted dinucleotide cap analog known in the art and/or described herein. Non-limiting examples of N7-(4-chlorophenoxyethyl) substituted dinucleotide cap analogs include a N7-(4-chlorophenoxyethyl)-G(5')ppp(5')G and a N7-(4-chlorophenoxyethyl)-m3'-OG(5')ppp(5')G cap analog (see, e.g., the various cap analogs and the methods of synthesizing cap analogs described in Kore et al. *Bioorganic & Medicinal Chemistry* 2013 21:4570-4574; the cap structures of which are herein incorporated by reference). In other instances, a cap analog useful in the polynucleotides of the present disclosure is a 4-chloro/bromophenoxyethyl analog.

[00428] While cap analogs allow for the concomitant capping of a polynucleotide in an *in vitro* transcription reaction, up to 20% of transcripts remain uncapped. This, as well as the structural differences of a cap analog from endogenous 5'-cap structures of polynucleotides produced by the endogenous, cellular transcription machinery, may lead to reduced translational competency and reduced cellular stability.

[00429] Alternative polynucleotides may also be capped post-transcriptionally, using enzymes, in order to generate more authentic 5'-cap structures. As used herein, the phrase “more authentic” refers to a feature that closely mirrors or mimics, either structurally or functionally, an endogenous or wild type feature. That is, a “more authentic” feature is better representative of an endogenous, wild-type, natural or physiological cellular function, and/or structure as compared to synthetic features or analogs of the prior art, or which outperforms the corresponding endogenous, wild-type, natural, or physiological feature in one or more respects. Non-limiting examples of more authentic 5'-cap structures useful in the polynucleotides of the present disclosure are those which, among other things, have enhanced binding of cap binding proteins, increased half-life, reduced susceptibility to 5'-endonucleases, and/or reduced 5'-decapping, as compared to synthetic 5'-cap structures known in the art (or to a wild-type, natural or physiological 5'-cap structure). In some embodiments, recombinant Vaccinia Virus Capping Enzyme and recombinant 2'-O-methyltransferase enzyme can create a canonical 5'-5'-triphosphate linkage between the 5'-terminal nucleotide of a polynucleotide and a guanosine cap nucleotide wherein the cap guanosine contains an N7-methylation and the 5'-terminal nucleotide of the polynucleotide contains a 2'-O-methyl. Such a structure is termed the Cap1 structure. This cap results in a higher translational-competency, cellular stability, and a reduced activation of cellular pro-inflammatory cytokines, as compared, *e.g.*, to other 5' cap analog structures known in the art. Other exemplary cap structures include 7mG(5')ppp(5')N,pN2p (Cap 0), 7mG(5')ppp(5')NlmpNp (Cap 1), 7mG(5')-ppp(5')NlmpN2mp (Cap 2), and m(7)Gpppm(3)(6,6,2')Apm(2')Apm(2')Cpm(2)(3,2')Up (Cap 4).

[00430] Because the alternative polynucleotides may be capped post-transcriptionally, and because this process is more efficient, nearly 100% of the alternative polynucleotides may be capped. This is in contrast to ~80% when a cap analog is linked to a polynucleotide in the course of an *in vitro* transcription reaction.

[00431] 5'-terminal caps may include endogenous caps or cap analogs. A 5'-terminal cap may include a guanosine analog. Useful guanosine analogs include inosine, N1-methyl-guanosine, 2'-fluoro-guanosine, 7-deaza-guanosine, 8-oxo-guanosine, 2-amino-guanosine, LNA-guanosine, and 2-azido-guanosine.

[00432] In some cases, a polynucleotide contains a modified 5'-cap. A modification on the 5'-cap may increase the stability of polynucleotide, increase the half-life of the polynucleotide, and could increase the polynucleotide translational efficiency. The modified 5'-cap may include, but is not limited to, one or more of the following modifications: modification at the 2'- and/or 3'-position of a capped guanosine triphosphate (GTP), a replacement of the sugar ring oxygen (that produced the carbocyclic ring) with a methylene moiety (CH₂), a modification at the triphosphate bridge moiety of the cap structure, or a modification at the nucleobase (G) moiety.

5'-UTRs

[00433] A 5'-UTR may be provided as a flanking region to polynucleotides (*e.g.*, mRNAs). A 5'-UTR may be homologous or heterologous to the coding region found in a polynucleotide. Multiple 5'-UTRs may be included in the flanking region and may be the same or of different sequences. Any portion of the flanking regions, including none, may be codon optimized and any may independently contain one or more different structural or chemical alterations, before and/or after codon optimization.

[00434] Shown in Table 21 in US Provisional Application No 61/775,509, and in Table 21 and in Table 22 in US Provisional Application No. 61/829,372, of which are incorporated herein by reference, is a listing of the start and stop site of alternative polynucleotides (*e.g.*, mRNA). In Table 21 each 5'-UTR (5'-UTR-005 to 5'-UTR 68511) is identified by its start and stop site relative to its native or wild type (homologous) transcript (ENST; the identifier used in the ENSEMBL database).

[00435] To alter one or more properties of a polynucleotide (*e.g.*, mRNA), 5'-UTRs which are heterologous to the coding region of an alternative polynucleotide (*e.g.*, mRNA) may be engineered. The polynucleotides (*e.g.*, mRNA) may then be administered to cells, tissue or organisms and outcomes such as protein level, localization, and/or half-life may be measured to evaluate the beneficial effects the heterologous 5'-UTR may have on the alternative polynucleotides (mRNA). Variants of the 5'-UTRs may be utilized wherein one or more

nucleotides are added or removed to the termini, including A, T, C or G. 5'-UTRs may also be codon-optimized, or altered in any manner described herein.

5'-UTRs, 3'-UTRs, and Translation Enhancer Elements (TEEs)

[00436] The 5'-UTR of a polynucleotides (*e.g.*, mRNA) may include at least one translation enhancer element. The term “translational enhancer element” refers to sequences that increase the amount of polypeptide or protein produced from a polynucleotide. As a non-limiting example, the TEE may be located between the transcription promoter and the start codon. The polynucleotides (*e.g.*, mRNA) with at least one TEE in the 5'-UTR may include a cap at the 5'-UTR. Further, at least one TEE may be located in the 5'-UTR of polynucleotides (*e.g.*, mRNA) undergoing cap-dependent or cap-independent translation.

[00437] In one aspect, TEEs are conserved elements in the UTR which can promote translational activity of a polynucleotide such as, but not limited to, cap-dependent or cap-independent translation. The conservation of these sequences has been previously shown by Panek et al. (Nucleic Acids Research, 2013, 1-10) across 14 species including humans.

[00438] In one non-limiting example, the TEEs known may be in the 5'-leader of the Gtx homeodomain protein (Chappell et al., Proc. Natl. Acad. Sci. USA 101:9590-9594, 2004, the TEEs of which are incorporated herein by reference).

[00439] In another non-limiting example, TEEs are disclosed in US Patent Publication Nos. 2009/0226470 and 2013/0177581, International Patent Publication Nos. WO2009/075886, WO2012/009644, and WO1999/024595, US Patent Nos. 6,310,197, and 6,849,405, the TEE sequences of each of which are incorporated herein by reference.

[00440] In yet another non-limiting example, the TEE may be an internal ribosome entry site (IRES), HCV-IRES or an IRES element such as, but not limited to, those described in US Patent No. 7,468,275, US Patent Publication Nos. 2007/0048776 and 2011/0124100 and International Patent Publication Nos. WO2007/025008 and WO2001/055369, the IRES sequences of each of which are incorporated herein by reference. The IRES elements may include, but are not limited to, the Gtx sequences (*e.g.*, Gtx9-nt, Gtx8-nt, Gtx7-nt) described by Chappell et al. (Proc. Natl. Acad. Sci. USA 101:9590-9594, 2004) and Zhou et al. (PNAS 102:6273-6278, 2005) and in US Patent Publication Nos. 2007/0048776 and 2011/0124100 and International Patent Publication

No. WO2007/025008, the IRES sequences of each of which are incorporated herein by reference.

[00441] “Translational enhancer polynucleotides” are polynucleotides which include one or more of the specific TEE exemplified herein and/or disclosed in the art (see *e.g.*, U.S. Patent Nos. 6,310,197, 6,849,405, 7,456,273, 7,183,395, U.S. Patent Publication Nos. 20090/226470, 2007/0048776, 2011/0124100, 2009/0093049, 2013/0177581, International Patent Publication Nos. WO2009/075886, WO2007/025008, WO2012/009644, WO2001/055371 WO1999/024595, and European Patent Nos. 2610341 and 2610340; the TEE sequences of each of which are incorporated herein by reference) or their variants, homologs or functional derivatives. One or multiple copies of a specific TEE can be present in a polynucleotide (*e.g.*, mRNA). The TEEs in the translational enhancer polynucleotides can be organized in one or more sequence segments. A sequence segment can harbor one or more of the specific TEEs exemplified herein, with each TEE being present in one or more copies. When multiple sequence segments are present in a translational enhancer polynucleotide, they can be homogenous or heterogeneous. Thus, the multiple sequence segments in a translational enhancer polynucleotide can harbor identical or different types of the specific TEEs exemplified herein, identical or different number of copies of each of the specific TEEs, and/or identical or different organization of the TEEs within each sequence segment.

[00442] A polynucleotide (*e.g.*, mRNA) may include at least one TEE that is described in International Patent Publication Nos. WO1999/024595, WO2012/009644, WO2009/075886, WO2007/025008, WO1999/024595, European Patent Publication Nos. 2610341 and 2610340, US Patent Nos. 6,310,197, 6,849,405, 7,456,273, 7,183,395, and US Patent Publication Nos. 2009/0226470, 2011/0124100, 2007/0048776, 2009/0093049, and 2013/0177581 the TEE sequences of each of which are incorporated herein by reference. The TEE may be located in the 5'-UTR of the polynucleotides (*e.g.*, mRNA).

[00443] A polynucleotide (*e.g.*, mRNA) may include at least one TEE that has at least 50%, at least 55%, at least 60%, at least 65%, at least 70%, at least 75%, at least 80%, at least 85%, at least 90%, at least 95% or at least 99% identity with the TEEs described in US Patent Publication Nos. 2009/0226470, 2007/0048776, 2013/0177581 and 2011/0124100, International Patent Publication Nos. WO1999/024595, WO2012/009644, WO2009/075886 and WO2007/025008,

European Patent Publication Nos. 2610341 and 2610340, US Patent Nos. 6,310,197, 6,849,405, 7,456,273, 7,183,395, the TEE sequences of each of which are incorporated herein by reference.

[00444] The 5'-UTR of a polynucleotide (*e.g.*, mRNA) may include at least 1, at least 2, at least 3, at least 4, at least 5, at least 6, at least 7, at least 8, at least 9, at least 10, at least 11, at least 12, at least 13, at least 14, at least 15, at least 16, at least 17, at least 18 at least 19, at least 20, at least 21, at least 22, at least 23, at least 24, at least 25, at least 30, at least 35, at least 40, at least 45, at least 50, at least 55 or more than 60 TEE sequences. The TEE sequences in the 5'-UTR of a polynucleotide (*e.g.*, mRNA) may be the same or different TEE sequences. The TEE sequences may be in a pattern such as ABABAB, AABBAABBAABB, or ABCABCABC, or variants thereof, repeated once, twice, or more than three times. In these patterns, each letter, A, B, or C represent a different TEE sequence at the nucleotide level.

[00445] In some cases, the 5'-UTR may include a spacer to separate two TEE sequences. As a non-limiting example, the spacer may be a 15 nucleotide spacer and/or other spacers known in the art. As another non-limiting example, the 5'-UTR may include a TEE sequence-spacer module repeated at least once, at least twice, at least 3 times, at least 4 times, at least 5 times, at least 6 times, at least 7 times, at least 8 times, at least 9 times, or more than 9 times in the 5'-UTR.

[00446] In other instances, the spacer separating two TEE sequences may include other sequences known in the art which may regulate the translation of the polynucleotides (*e.g.*, mRNA) of the present disclosure such as, but not limited to, miR sequences (*e.g.*, miR binding sites and miR seeds). As a non-limiting example, each spacer used to separate two TEE sequences may include a different miR sequence or component of a miR sequence (*e.g.*, miR seed sequence).

[00447] In some instances, the TEE in the 5'-UTR of a polynucleotide (*e.g.*, mRNA) may include at least 5%, at least 10%, at least 15%, at least 20%, at least 25%, at least 30%, at least 35%, at least 40%, at least 45%, at least 50%, at least 55%, at least 60%, at least 65%, at least 70%, at least 75%, at least 80%, at least 85%, at least 90%, at least 95%, at least 99% or more than 99% of the TEE sequences disclosed in US Patent Publication Nos. 2009/0226470, 2007/0048776, 2013/0177581 and 2011/0124100, International Patent Publication Nos. WO1999/024595, WO2012/009644, WO2009/075886 and WO2007/025008, European Patent Publication Nos. 2610341 and 2610340, and US Patent Nos. 6,310,197, 6,849,405, 7,456,273,

and 7,183,395 the TEE sequences of each of which are incorporated herein by reference. In another embodiment, the TEE in the 5'-UTR of the polynucleotides (*e.g.*, mRNA) of the present disclosure may include a 5-30 nucleotide fragment, a 5-25 nucleotide fragment, a 5-20 nucleotide fragment, a 5-15 nucleotide fragment, a 5-10 nucleotide fragment of the TEE sequences disclosed in US Patent Publication Nos. 2009/0226470, 2007/0048776, 2013/0177581 and 2011/0124100, International Patent Publication Nos. WO1999/024595, WO2012/009644, WO2009/075886 and WO2007/025008, European Patent Publication Nos. 2610341 and 2610340, and US Patent Nos. 6,310,197, 6,849,405, 7,456,273, and 7,183,395; the TEE sequences of each of which are incorporated herein by reference.

[00448] In certain cases, the TEE in the 5'-UTR of the polynucleotides (*e.g.*, mRNA) of the present disclosure may include at least 5%, at least 10%, at least 15%, at least 20%, at least 25%, at least 30%, at least 35%, at least 40%, at least 45%, at least 50%, at least 55%, at least 60%, at least 65%, at least 70%, at least 75%, at least 80%, at least 85%, at least 90%, at least 95%, at least 99% or more than 99% of the TEE sequences disclosed in Chappell et al. (Proc. Natl. Acad. Sci. USA 101:9590-9594, 2004) and Zhou et al. (PNAS 102:6273-6278, 2005), in Supplemental Table 1 and in Supplemental Table 2 disclosed by Wellensiek et al (Genome-wide profiling of human cap-independent translation-enhancing elements, Nature Methods, 2013; DOI:10.1038/NMETH.2522); the TEE sequences of each of which are herein incorporated by reference. In another embodiment, the TEE in the 5'-UTR of the polynucleotides (*e.g.*, mRNA) of the present disclosure may include a 5-30 nucleotide fragment, a 5-25 nucleotide fragment, a 5-20 nucleotide fragment, a 5-15 nucleotide fragment, a 5-10 nucleotide fragment of the TEE sequences disclosed in Chappell et al. (Proc. Natl. Acad. Sci. USA 101:9590-9594, 2004) and Zhou et al. (PNAS 102:6273-6278, 2005), in Supplemental Table 1 and in Supplemental Table 2 disclosed by Wellensiek et al (Genome-wide profiling of human cap-independent translation-enhancing elements, Nature Methods, 2013; DOI:10.1038/NMETH.2522); the TEE sequences of each of which is incorporated herein by reference.

[00449] In some cases, the TEE used in the 5'-UTR of a polynucleotide (*e.g.*, mRNA) is an IRES sequence such as, but not limited to, those described in US Patent No. 7,468,275 and International Patent Publication No. WO2001/055369, the TEE sequences of each of which are incorporated herein by reference.

[00450] In some instances, the TEEs used in the 5'-UTR of a polynucleotide (*e.g.*, mRNA) may be identified by the methods described in US Patent Publication Nos. 2007/0048776 and 2011/0124100 and International Patent Publication Nos. WO2007/025008 and WO2012/009644, the methods of each of which are incorporated herein by reference.

[00451] In some cases, the TEEs used in the 5'-UTR of a polynucleotide (*e.g.*, mRNA) of the present disclosure may be a transcription regulatory element described in US Patent Nos. 7,456,273 and 7,183,395, US Patent Publication No. 2009/0093049, and International Publication No. WO2001/055371, the TEE sequences of each of which is incorporated herein by reference. The transcription regulatory elements may be identified by methods known in the art, such as, but not limited to, the methods described in US Patent Nos. 7,456,273 and 7,183,395, US Patent Publication No. 2009/0093049, and International Publication No. WO2001/055371, the methods of each of which is incorporated herein by reference.

[00452] In yet other instances, the TEE used in the 5'-UTR of a polynucleotide (*e.g.*, mRNA) is a polynucleotide or portion thereof as described in US Patent Nos. 7,456,273 and 7,183,395, US Patent Publication No. 2009/0093049, and International Publication No. WO2001/055371, the TEE sequences of each of which are incorporated herein by reference.

[00453] The 5'-UTR including at least one TEE described herein may be incorporated in a monocistronic sequence such as, but not limited to, a vector system or a polynucleotide vector. As a non-limiting example, the vector systems and polynucleotide vectors may include those described in US Patent Nos. 7,456,273 and 7,183,395, US Patent Publication Nos. 2007/0048776, 2009/0093049 and 2011/0124100, and International Patent Publication Nos. WO2007/025008 and WO2001/055371, the TEE sequences of each of which are incorporated herein by reference.

[00454] The TEEs described herein may be located in the 5'-UTR and/or the 3'-UTR of the polynucleotides (*e.g.*, mRNA). The TEEs located in the 3'-UTR may be the same and/or different than the TEEs located in and/or described for incorporation in the 5'-UTR.

[00455] In some cases, the 3'-UTR of a polynucleotide (*e.g.*, mRNA) may include at least 1, at least 2, at least 3, at least 4, at least 5, at least 6, at least 7, at least 8, at least 9, at least 10, at least 11, at least 12, at least 13, at least 14, at least 15, at least 16, at least 17, at least 18 at least 19, at least 20, at least 21, at least 22, at least 23, at least 24, at least 25, at least 30, at least 35, at least 40, at least 45, at least 50, at least 55 or more than 60 TEE sequences. The TEE sequences

in the 3'-UTR of the polynucleotides (*e.g.*, mRNA) of the present disclosure may be the same or different TEE sequences. The TEE sequences may be in a pattern such as ABABAB, AABBAABBAABB, or ABCABCABC, or variants thereof, repeated once, twice, or more than three times. In these patterns, each letter, A, B, or C represent a different TEE sequence at the nucleotide level.

[00456] In one instance, the 3'-UTR may include a spacer to separate two TEE sequences. As a non-limiting example, the spacer may be a 15 nucleotide spacer and/or other spacers known in the art. As another non-limiting example, the 3'-UTR may include a TEE sequence-spacer module repeated at least once, at least twice, at least 3 times, at least 4 times, at least 5 times, at least 6 times, at least 7 times, at least 8 times, at least 9 times, or more than 9 times in the 3'-UTR.

[00457] In other cases, the spacer separating two TEE sequences may include other sequences known in the art which may regulate the translation of the polynucleotides (*e.g.*, mRNA) of the present disclosure such as, but not limited to, miR sequences described herein (*e.g.*, miR binding sites and miR seeds). As a non-limiting example, each spacer used to separate two TEE sequences may include a different miR sequence or component of a miR sequence (*e.g.*, miR seed sequence).

[00458] In some embodiments, a polyribonucleotide of the disclosure comprises a miR and/or TEE sequence. In some embodiments, the incorporation of a miR sequence and/or a TEE sequence into a polyribonucleotide of the disclosure can change the shape of the stem loop region, which can increase and/or decrease translation. See *e.g.*, Kedde et al., *Nature Cell Biology* 2010 12(10):1014-20, herein incorporated by reference in its entirety).

Sensor Sequences and MicroRNA (miRNA) Binding Sites

[00459] Sensor sequences include, for example, microRNA (miRNA) binding sites, transcription factor binding sites, structured mRNA sequences and/or motifs, artificial binding sites engineered to act as pseudo-receptors for endogenous nucleic acid binding molecules, and combinations thereof. Non-limiting examples of sensor sequences are described in U.S. Publication 2014/0200261, the contents of which are incorporated herein by reference in their entirety.

[00460] In some embodiments, a polyribonucleotide (e.g., a ribonucleic acid (RNA), e.g., a messenger RNA (mRNA)) of the disclosure comprising an open reading frame (ORF) encoding a polypeptide further comprises a sensor sequence. In some embodiments, the sensor sequence is a miRNA binding site.

[00461] A miRNA is a 19-25 nucleotide long noncoding RNA that binds to a polyribonucleotide and down-regulates gene expression either by reducing stability or by inhibiting translation of the polyribonucleotide. A miRNA sequence comprises a “seed” region, i.e., a sequence in the region of positions 2-8 of the mature miRNA. A miRNA seed can comprise positions 2-8 or 2-7 of the mature miRNA. In some embodiments, a miRNA seed can comprise 7 nucleotides (e.g., nucleotides 2-8 of the mature miRNA), wherein the seed-complementary site in the corresponding miRNA binding site is flanked by an adenosine (A) opposed to miRNA position 1. In some embodiments, a miRNA seed can comprise 6 nucleotides (e.g., nucleotides 2-7 of the mature miRNA), wherein the seed-complementary site in the corresponding miRNA binding site is flanked by an adenosine (A) opposed to miRNA position 1. See, for example, Grimson A, Farh KK, Johnston WK, Garrett-Engele P, Lim LP, Bartel DP; Mol Cell. 2007 Jul 6;27(1):91-105. miRNA profiling of the target cells or tissues can be conducted to determine the presence or absence of miRNA in the cells or tissues. In some embodiments, a polyribonucleotide (e.g., a ribonucleic acid (RNA), e.g., a messenger RNA (mRNA)) of the disclosure comprises one or more microRNA target sequences, microRNA sequences, or microRNA seeds. Such sequences can correspond to any known microRNA such as those taught in US Publication US2005/0261218 and US Publication US2005/0059005, the contents of each of which are incorporated herein by reference in their entirety.

[00462] As used herein, the term “microRNA (miRNA or miR) binding site” refers to a sequence within a polyribonucleotide, e.g., within a DNA or within an RNA transcript, including in the 5'UTR and/or 3'UTR, that has sufficient complementarity to all or a region of a miRNA to interact with, associate with or bind to the miRNA. In some embodiments, a polyribonucleotide of the disclosure comprising an ORF encoding a polypeptide further comprises a miRNA binding site. In exemplary embodiments, a 5'UTR and/or 3'UTR of the polyribonucleotide (e.g., a ribonucleic acid (RNA), e.g., a messenger RNA (mRNA)) comprises a miRNA binding site.

[00463] A miRNA binding site having sufficient complementarity to a miRNA refers to a degree of complementarity sufficient to facilitate miRNA-mediated regulation of a

polyribonucleotide, e.g., miRNA-mediated translational repression or degradation of the polyribonucleotide. In exemplary aspects of the disclosure, a miRNA binding site having sufficient complementarity to the miRNA refers to a degree of complementarity sufficient to facilitate miRNA-mediated degradation of the polyribonucleotide, e.g., miRNA-guided RNA-induced silencing complex (RISC)-mediated cleavage of mRNA. The miRNA binding site can have complementarity to, for example, a 19-25 nucleotide miRNA sequence, to a 19-23 nucleotide miRNA sequence, or to a 22 nucleotide miRNA sequence. A miRNA binding site can be complementary to only a portion of a miRNA, e.g., to a portion less than 1, 2, 3, or 4 nucleotides of the full length of a naturally-occurring miRNA sequence. Full or complete complementarity (e.g., full complementarity or complete complementarity over all or a significant portion of the length of a naturally-occurring miRNA) is preferred when the desired regulation is mRNA degradation.

[00464] In some embodiments, a miRNA binding site includes a sequence that has complementarity (e.g., partial or complete complementarity) with an miRNA seed sequence. In some embodiments, the miRNA binding site includes a sequence that has complete complementarity with a miRNA seed sequence. In some embodiments, a miRNA binding site includes a sequence that has complementarity (e.g., partial or complete complementarity) with an miRNA sequence. In some embodiments, the miRNA binding site includes a sequence that has complete complementarity with a miRNA sequence. In some embodiments, a miRNA binding site has complete complementarity with a miRNA sequence but for 1, 2, or 3 nucleotide substitutions, terminal additions, and/or truncations.

[00465] In some embodiments, the miRNA binding site is the same length as the corresponding miRNA. In some embodiments, the miRNA binding site is one, two, three, four, five, six, seven, eight, nine, ten, eleven or twelve nucleotide(s) shorter than the corresponding miRNA at the 5' terminus, the 3' terminus, or both. In still other embodiments, the microRNA binding site is two nucleotides shorter than the corresponding microRNA at the 5' terminus, the 3' terminus, or both. The miRNA binding sites that are shorter than the corresponding miRNAs are still capable of degrading the mRNA incorporating one or more of the miRNA binding sites or preventing the mRNA from translation.

[00466] In some embodiments, the miRNA binding site binds to the corresponding mature miRNA that is part of an active RISC containing Dicer. In another embodiment, binding of the

miRNA binding site to the corresponding miRNA in RISC degrades the mRNA containing the miRNA binding site or prevents the mRNA from being translated. In some embodiments, the miRNA binding site has sufficient complementarity to miRNA so that a RISC complex comprising the miRNA cleaves the polyribonucleotide comprising the miRNA binding site. In some embodiments, the miRNA binding site has imperfect complementarity so that a RISC complex comprising the miRNA induces instability in the polyribonucleotide comprising the miRNA binding site. In another embodiment, the miRNA binding site has imperfect complementarity so that a RISC complex comprising the miRNA represses transcription of the polyribonucleotide comprising the miRNA binding site.

[00467] In some embodiments, the miRNA binding site has one, two, three, four, five, six, seven, eight, nine, ten, eleven or twelve mismatch(es) from the corresponding miRNA.

[00468] In some embodiments, the miRNA binding site has at least about ten, at least about eleven, at least about twelve, at least about thirteen, at least about fourteen, at least about fifteen, at least about sixteen, at least about seventeen, at least about eighteen, at least about nineteen, at least about twenty, or at least about twenty-one contiguous nucleotides complementary to at least about ten, at least about eleven, at least about twelve, at least about thirteen, at least about fourteen, at least about fifteen, at least about sixteen, at least about seventeen, at least about eighteen, at least about nineteen, at least about twenty, or at least about twenty-one, respectively, contiguous nucleotides of the corresponding miRNA.

[00469] By engineering one or more miRNA binding sites into a polyribonucleotide of the disclosure, the polyribonucleotide can be targeted for degradation or reduced translation, provided the miRNA in question is available. This can reduce off-target effects upon delivery of the polyribonucleotide. In some embodiments, if a polyribonucleotide of the disclosure is not intended to be delivered to a tissue or cell but ends up there, then a miRNA abundant in the tissue or cell can inhibit the expression of the gene of interest if one or multiple binding sites of the miRNA are engineered into the 5'UTR and/or 3'UTR of the polyribonucleotide.

[00470] Conversely, miRNA binding sites can be removed from polyribonucleotide sequences in which they naturally occur in order to increase protein expression in specific tissues. In some embodiments, a binding site for a specific miRNA can be removed from a polyribonucleotide to improve protein expression in tissues or cells containing the miRNA.

[00471] In some embodiments, a polyribonucleotide of the disclosure can include at least one miRNA-binding site in the 5'UTR and/or 3'UTR in order to direct cytotoxic or cytoprotective mRNA therapeutics to specific cells such as, but not limited to, normal and/or cancerous cells. In another embodiment, a polyribonucleotide of the disclosure can include two, three, four, five, six, seven, eight, nine, ten, or more miRNA-binding sites in the 5'-UTR and/or 3'-UTR in order to direct cytotoxic or cytoprotective mRNA therapeutics to specific cells such as, but not limited to, normal and/or cancerous cells.

[00472] Regulation of expression in multiple tissues can be accomplished through introduction or removal of one or more miRNA binding sites. The decision whether to remove or insert a miRNA binding site can be made based on miRNA expression patterns and/or their profilings in diseases. Identification of miRNAs, miRNA binding sites, and their expression patterns and role in biology have been reported (e.g., Bonauer et al., *Curr Drug Targets* 2010 11:943-949; Anand and Cheresch *Curr Opin Hematol* 2011 18:171-176; Contreras and Rao *Leukemia* 2012 26:404-413 (2011 Dec 20. doi: 10.1038/leu.2011.356); Bartel *Cell* 2009 136:215-233; Landgraf et al, *Cell*, 2007 129:1401-1414; Gentner and Naldini, *Tissue Antigens*. 2012 80:393-403 and all references therein; each of which is incorporated herein by reference in its entirety).

[00473] miRNAs and miRNA binding sites can correspond to any known sequence, including non-limiting examples described in U.S. Publication Nos. 2014/0200261, 2005/0261218, and 2005/0059005, each of which are incorporated herein by reference in their entirety.

[00474] Examples of tissues where miRNA are known to regulate mRNA, and thereby protein expression, include, but are not limited to, liver (miR-122), muscle (miR-133, miR-206, miR-208), endothelial cells (miR-17-92, miR-126), myeloid cells (miR-142-3p, miR-142-5p, miR-16, miR-21, miR-223, miR-24, miR-27), adipose tissue (let-7, miR-30c), heart (miR-1d, miR-149), kidney (miR-192, miR-194, miR-204), and lung epithelial cells (let-7, miR-133, miR-126).

[00475] Specifically, miRNAs are known to be differentially expressed in immune cells (also called hematopoietic cells), such as antigen presenting cells (APCs) (e.g., dendritic cells and macrophages), macrophages, monocytes, B lymphocytes, T lymphocytes, granulocytes, natural killer cells, etc. Immune cell specific miRNAs are involved in immunogenicity, autoimmunity, the immune-response to infection, inflammation, as well as unwanted immune response after gene therapy and tissue/organ transplantation. Immune cells specific miRNAs also regulate many

aspects of development, proliferation, differentiation and apoptosis of hematopoietic cells (immune cells). In some embodiments, miR-142 and miR-146 are exclusively expressed in immune cells, particularly abundant in myeloid dendritic cells. It has been demonstrated that the immune response to a polyribonucleotide can be shut-off by adding miR-142 binding sites to the 3'-UTR of the polyribonucleotide, enabling more stable gene transfer in tissues and cells. miR-142 efficiently degrades exogenous polyribonucleotides in antigen presenting cells and suppresses cytotoxic elimination of transduced cells (e.g., Annoni A et al., blood, 2009, 114, 5152-5161; Brown BD, et al., Nat med. 2006, 12(5), 585-591; Brown BD, et al., blood, 2007, 110(13): 4144-4152, each of which is incorporated herein by reference in its entirety).

[00476] An antigen-mediated immune response can refer to an immune response triggered by foreign antigens, which, when entering an organism, are processed by the antigen presenting cells and displayed on the surface of the antigen presenting cells. T cells can recognize the presented antigen and induce a cytotoxic elimination of cells that express the antigen.

[00477] Introducing a miR-142 binding site into the 5'UTR and/or 3'UTR of a polyribonucleotide of the disclosure can selectively repress gene expression in antigen presenting cells through miR-142 mediated degradation, limiting antigen presentation in antigen presenting cells (e.g., dendritic cells) and thereby preventing antigen-mediated immune response after the delivery of the polyribonucleotide. The polyribonucleotide is then stably expressed in target tissues or cells without triggering cytotoxic elimination.

[00478] In some embodiments, binding sites for miRNAs that are known to be expressed in immune cells, in particular, antigen presenting cells, can be engineered into a polyribonucleotide of the disclosure to suppress the expression of the polyribonucleotide in antigen presenting cells through miRNA mediated RNA degradation, subduing the antigen-mediated immune response. Expression of the polyribonucleotide is maintained in non-immune cells where the immune cell specific miRNAs are not expressed. In some embodiments, in some embodiments, to prevent an immunogenic reaction against a liver specific protein, any miR-122 binding site can be removed and a miR-142 (and/or mirR-146) binding site can be engineered into the 5'UTR and/or 3'UTR of a polyribonucleotide of the disclosure.

[00479] To further drive the selective degradation and suppression in APCs and macrophage, a polyribonucleotide of the disclosure can include a further negative regulatory element in the 5'UTR and/or 3'UTR, either alone or in combination with miR-142 and/or miR-146 binding sites.

As a non-limiting example, the further negative regulatory element is a Constitutive Decay Element (CDE).

[00480] Immune cell specific miRNAs include, but are not limited to, hsa-let-7a-2-3p, hsa-let-7a-3p, hsa-7a-5p, hsa-let-7c, hsa-let-7e-3p, hsa-let-7e-5p, hsa-let-7g-3p, hsa-let-7g-5p, hsa-let-7i-3p, hsa-let-7i-5p, miR-10a-3p, miR-10a-5p, miR-1184, hsa-let-7f-1--3p, hsa-let-7f-2--5p, hsa-let-7f-5p, miR-125b-1-3p, miR-125b-2-3p, miR-125b-5p, miR-1279, miR-130a-3p, miR-130a-5p, miR-132-3p, miR-132-5p, miR-142-3p, miR-142-5p, miR-143-3p, miR-143-5p, miR-146a-3p, miR-146a-5p, miR-146b-3p, miR-146b-5p, miR-147a, miR-147b, miR-148a-5p, miR-148a-3p, miR-150-3p, miR-150-5p, miR-151b, miR-155-3p, miR-155-5p, miR-15a-3p, miR-15a-5p, miR-15b-5p, miR-15b-3p, miR-16-1-3p, miR-16-2-3p, miR-16-5p, miR-17-5p, miR-181a-3p, miR-181a-5p, miR-181a-2-3p, miR-182-3p, miR-182-5p, miR-197-3p, miR-197-5p, miR-21-5p, miR-21-3p, miR-214-3p, miR-214-5p, miR-223-3p, miR-223-5p, miR-221-3p, miR-221-5p, miR-23b-3p, miR-23b-5p, miR-24-1-5p, miR-24-2-5p, miR-24-3p, miR-26a-1-3p, miR-26a-2-3p, miR-26a-5p, miR-26b-3p, miR-26b-5p, miR-27a-3p, miR-27a-5p, miR-27b-3p, miR-27b-5p, miR-28-3p, miR-28-5p, miR-2909, miR-29a-3p, miR-29a-5p, miR-29b-1-5p, miR-29b-2-5p, miR-29c-3p, miR-29c-5p, miR-30e-3p, miR-30e-5p, miR-331-5p, miR-339-3p, miR-339-5p, miR-345-3p, miR-345-5p, miR-346, miR-34a-3p, miR-34a-5p, , miR-363-3p, miR-363-5p, miR-372, miR-377-3p, miR-377-5p, miR-493-3p, miR-493-5p, miR-542, miR-548b-5p, miR-548c-5p, miR-548i, miR-548j, miR-548n, miR-574-3p, miR-598, miR-718, miR-935, miR-99a-3p, miR-99a-5p, miR-99b-3p, and miR-99b-5p. Furthermore, novel miRNAs can be identified in immune cell through micro-array hybridization and microtome analysis (e.g., Jima DD et al, Blood, 2010, 116:e118-e127; Vaz C et al., BMC Genomics, 2010, 11,288, the content of each of which is incorporated herein by reference in its entirety.)

[00481] miRNAs that are known to be expressed in the liver include, but are not limited to, miR-107, miR-122-3p, miR-122-5p, miR-1228-3p, miR-1228-5p, miR-1249, miR-129-5p, miR-1303, miR-151a-3p, miR-151a-5p, miR-152, miR-194-3p, miR-194-5p, miR-199a-3p, miR-199a-5p, miR-199b-3p, miR-199b-5p, miR-296-5p, miR-557, miR-581, miR-939-3p, and miR-939-5p. miRNA binding sites from any liver specific miRNA can be introduced to or removed from a polyribonucleotide of the disclosure to regulate expression of the polyribonucleotide in the liver. Liver specific miRNA binding sites can be engineered alone or further in combination with immune cell (e.g., APC) miRNA binding sites in a polyribonucleotide of the disclosure.

[00482] miRNAs that are known to be expressed in the lung include, but are not limited to, let-7a-2-3p, let-7a-3p, let-7a-5p, miR-126-3p, miR-126-5p, miR-127-3p, miR-127-5p, miR-130a-3p, miR-130a-5p, miR-130b-3p, miR-130b-5p, miR-133a, miR-133b, miR-134, miR-18a-3p, miR-18a-5p, miR-18b-3p, miR-18b-5p, miR-24-1-5p, miR-24-2-5p, miR-24-3p, miR-296-3p, miR-296-5p, miR-32-3p, miR-337-3p, miR-337-5p, miR-381-3p, and miR-381-5p. MiRNA binding sites from any lung specific miRNA can be introduced to or removed from a polyribonucleotide of the disclosure to regulate expression of the polyribonucleotide in the lung. Lung specific miRNA binding sites can be engineered alone or further in combination with immune cell (e.g., APC) miRNA binding sites in a polyribonucleotide of the disclosure.

[00483] miRNAs that are known to be expressed in the heart include, but are not limited to, miR-1, miR-133a, miR-133b, miR-149-3p, miR-149-5p, miR-186-3p, miR-186-5p, miR-208a, miR-208b, miR-210, miR-296-3p, miR-320, miR-451a, miR-451b, miR-499a-3p, miR-499a-5p, miR-499b-3p, miR-499b-5p, miR-744-3p, miR-744-5p, miR-92b-3p, and miR-92b-5p. MiRNA binding sites from any heart specific microRNA can be introduced to or removed from a polyribonucleotide of the disclosure to regulate expression of the polyribonucleotide in the heart. Heart specific miRNA binding sites can be engineered alone or further in combination with immune cell (e.g., APC) miRNA binding sites in a polyribonucleotide of the disclosure.

[00484] miRNAs that are known to be expressed in the nervous system include, but are not limited to, miR-124-5p, miR-125a-3p, miR-125a-5p, miR-125b-1-3p, miR-125b-2-3p, miR-125b-5p, miR-1271-3p, miR-1271-5p, miR-128, miR-132-5p, miR-135a-3p, miR-135a-5p, miR-135b-3p, miR-135b-5p, miR-137, miR-139-5p, miR-139-3p, miR-149-3p, miR-149-5p, miR-153, miR-181c-3p, miR-181c-5p, miR-183-3p, miR-183-5p, miR-190a, miR-190b, miR-212-3p, miR-212-5p, miR-219-1-3p, miR-219-2-3p, miR-23a-3p, miR-23a-5p, miR-30a-5p, miR-30b-3p, miR-30b-5p, miR-30c-1-3p, miR-30c-2-3p, miR-30c-5p, miR-30d-3p, miR-30d-5p, miR-329, miR-342-3p, miR-3665, miR-3666, miR-380-3p, miR-380-5p, miR-383, miR-410, miR-425-3p, miR-425-5p, miR-454-3p, miR-454-5p, miR-483, miR-510, miR-516a-3p, miR-548b-5p, miR-548c-5p, miR-571, miR-7-1-3p, miR-7-2-3p, miR-7-5p, miR-802, miR-922, miR-9-3p, and miR-9-5p. MiRNAs enriched in the nervous system further include those specifically expressed in neurons, including, but not limited to, miR-132-3p, miR-132-5p, miR-148b-3p, miR-148b-5p, miR-151a-3p, miR-151a-5p, miR-212-3p, miR-212-5p, miR-320b, miR-320e, miR-323a-3p, miR-323a-5p, miR-324-5p, miR-325, miR-326, miR-328, miR-922 and those specifically

expressed in glial cells, including, but not limited to, miR-1250, miR-219-1-3p, miR-219-2-3p, miR-219-5p, miR-23a-3p, miR-23a-5p, miR-3065-3p, miR-3065-5p, miR-30e-3p, miR-30e-5p, miR-32-5p, miR-338-5p, and miR-657. MiRNA binding sites from any CNS specific miRNA can be introduced to or removed from a polyribonucleotide of the disclosure to regulate expression of the polyribonucleotide in the nervous system. Nervous system specific miRNA binding sites can be engineered alone or further in combination with immune cell (e.g., APC) miRNA binding sites in a polyribonucleotide of the disclosure.

[00485] miRNAs that are known to be expressed in the pancreas include, but are not limited to, miR-105-3p, miR-105-5p, miR-184, miR-195-3p, miR-195-5p, miR-196a-3p, miR-196a-5p, miR-214-3p, miR-214-5p, miR-216a-3p, miR-216a-5p, miR-30a-3p, miR-33a-3p, miR-33a-5p, miR-375, miR-7-1-3p, miR-7-2-3p, miR-493-3p, miR-493-5p, and miR-944. MiRNA binding sites from any pancreas specific miRNA can be introduced to or removed from a polyribonucleotide of the disclosure to regulate expression of the polyribonucleotide in the pancreas. Pancreas specific miRNA binding sites can be engineered alone or further in combination with immune cell (e.g., APC) miRNA binding sites in a polyribonucleotide of the disclosure.

[00486] miRNAs that are known to be expressed in the kidney include, but are not limited to, miR-122-3p, miR-145-5p, miR-17-5p, miR-192-3p, miR-192-5p, miR-194-3p, miR-194-5p, miR-20a-3p, miR-20a-5p, miR-204-3p, miR-204-5p, miR-210, miR-216a-3p, miR-216a-5p, miR-296-3p, miR-30a-3p, miR-30a-5p, miR-30b-3p, miR-30b-5p, miR-30c-1-3p, miR-30c-2-3p, miR-30c-5p, miR-324-3p, miR-335-3p, miR-335-5p, miR-363-3p, miR-363-5p, and miR-562. MiRNA binding sites from any kidney specific miRNA can be introduced to or removed from a polyribonucleotide of the disclosure to regulate expression of the polyribonucleotide in the kidney. Kidney specific miRNA binding sites can be engineered alone or further in combination with immune cell (e.g., APC) miRNA binding sites in a polyribonucleotide of the disclosure.

[00487] miRNAs that are known to be expressed in the muscle include, but are not limited to, let-7g-3p, let-7g-5p, miR-1, miR-1286, miR-133a, miR-133b, miR-140-3p, miR-143-3p, miR-143-5p, miR-145-3p, miR-145-5p, miR-188-3p, miR-188-5p, miR-206, miR-208a, miR-208b, miR-25-3p, and miR-25-5p. MiRNA binding sites from any muscle specific miRNA can be introduced to or removed from a polyribonucleotide of the disclosure to regulate expression of the polyribonucleotide in the muscle. Muscle specific miRNA binding sites can be engineered

alone or further in combination with immune cell (e.g., APC) miRNA binding sites in a polyribonucleotide of the disclosure.

[00488] miRNAs are also differentially expressed in different types of cells, such as, but not limited to, endothelial cells, epithelial cells, and adipocytes.

[00489] miRNAs that are known to be expressed in endothelial cells include, but are not limited to, let-7b-3p, let-7b-5p, miR-100-3p, miR-100-5p, miR-101-3p, miR-101-5p, miR-126-3p, miR-126-5p, miR-1236-3p, miR-1236-5p, miR-130a-3p, miR-130a-5p, miR-17-5p, miR-17-3p, miR-18a-3p, miR-18a-5p, miR-19a-3p, miR-19a-5p, miR-19b-1-5p, miR-19b-2-5p, miR-19b-3p, miR-20a-3p, miR-20a-5p, miR-217, miR-210, miR-21-3p, miR-21-5p, miR-221-3p, miR-221-5p, miR-222-3p, miR-222-5p, miR-23a-3p, miR-23a-5p, miR-296-5p, miR-361-3p, miR-361-5p, miR-421, miR-424-3p, miR-424-5p, miR-513a-5p, miR-92a-1-5p, miR-92a-2-5p, miR-92a-3p, miR-92b-3p, and miR-92b-5p. Many novel miRNAs are discovered in endothelial cells from deep-sequencing analysis (e.g., Voellenkle C et al., RNA, 2012, 18, 472-484, herein incorporated by reference in its entirety). MiRNA binding sites from any endothelial cell specific miRNA can be introduced to or removed from a polyribonucleotide of the disclosure to regulate expression of the polyribonucleotide in the endothelial cells.

[00490] miRNAs that are known to be expressed in epithelial cells include, but are not limited to, let-7b-3p, let-7b-5p, miR-1246, miR-200a-3p, miR-200a-5p, miR-200b-3p, miR-200b-5p, miR-200c-3p, miR-200c-5p, miR-338-3p, miR-429, miR-451a, miR-451b, miR-494, miR-802 and miR-34a, miR-34b-5p, miR-34c-5p, miR-449a, miR-449b-3p, miR-449b-5p specific in respiratory ciliated epithelial cells, let-7 family, miR-133a, miR-133b, miR-126 specific in lung epithelial cells, miR-382-3p, miR-382-5p specific in renal epithelial cells, and miR-762 specific in corneal epithelial cells. MiRNA binding sites from any epithelial cell specific miRNA can be introduced to or removed from a polyribonucleotide of the disclosure to regulate expression of the polyribonucleotide in the epithelial cells.

[00491] In addition, a large group of miRNAs are enriched in embryonic stem cells, controlling stem cell self-renewal as well as the development and/or differentiation of various cell lineages, such as neural cells, cardiac, hematopoietic cells, skin cells, osteogenic cells and muscle cells (e.g., Kuppasamy KT et al., Curr. Mol Med, 2013, 13(5), 757-764; Vidigal JA and Ventura A, Semin Cancer Biol. 2012, 22(5-6), 428-436; Goff LA et al., PLoS One, 2009, 4:e7192; Morin RD et al., Genome Res, 2008, 18, 610-621; Yoo JK et al., Stem Cells Dev. 2012,

21(11), 2049-2057, each of which is herein incorporated by reference in its entirety). MiRNAs abundant in embryonic stem cells include, but are not limited to, let-7a-2-3p, let-a-3p, let-7a-5p, let7d-3p, let-7d-5p, miR-103a-2-3p, miR-103a-5p, miR-106b-3p, miR-106b-5p, miR-1246, miR-1275, miR-138-1-3p, miR-138-2-3p, miR-138-5p, miR-154-3p, miR-154-5p, miR-200c-3p, miR-200c-5p, miR-290, miR-301a-3p, miR-301a-5p, miR-302a-3p, miR-302a-5p, miR-302b-3p, miR-302b-5p, miR-302c-3p, miR-302c-5p, miR-302d-3p, miR-302d-5p, miR-302e, miR-367-3p, miR-367-5p, miR-369-3p, miR-369-5p, miR-370, miR-371, miR-373, miR-380-5p, miR-423-3p, miR-423-5p, miR-486-5p, miR-520c-3p, miR-548e, miR-548f, miR-548g-3p, miR-548g-5p, miR-548i, miR-548k, miR-548l, miR-548m, miR-548n, miR-548o-3p, miR-548o-5p, miR-548p, miR-664a-3p, miR-664a-5p, miR-664b-3p, miR-664b-5p, miR-766-3p, miR-766-5p, miR-885-3p, miR-885-5p, miR-93-3p, miR-93-5p, miR-941, miR-96-3p, miR-96-5p, miR-99b-3p and miR-99b-5p. Many predicted novel miRNAs are discovered by deep sequencing in human embryonic stem cells (e.g., Morin RD et al., *Genome Res*, 2008, 18, 610-621; Goff LA et al., *PLoS One*, 2009, 4:e7192; Bar M et al., *Stem cells*, 2008, 26, 2496-2505, the content of each of which is incorporated herein by reference in its entirety).

[00492] In some embodiments, the binding sites of embryonic stem cell specific miRNAs can be included in or removed from the 3'UTR of a polyribonucleotide of the disclosure to modulate the development and/or differentiation of embryonic stem cells, to inhibit the senescence of stem cells in a degenerative condition (e.g., degenerative diseases), or to stimulate the senescence and apoptosis of stem cells in a disease condition (e.g., cancer stem cells).

[00493] Many miRNA expression studies are conducted to profile the differential expression of miRNAs in various cancer cells/tissues and other diseases. Some miRNAs are abnormally over-expressed in certain cancer cells and others are under-expressed. In some embodiments, miRNAs are differentially expressed in cancer cells (WO2008/154098, US2013/0059015, US2013/0042333, WO2011/157294); cancer stem cells (US2012/0053224); pancreatic cancers and diseases (US2009/0131348, US2011/0171646, US2010/0286232, US8389210); asthma and inflammation (US8415096); prostate cancer (US2013/0053264); hepatocellular carcinoma (WO2012/151212, US2012/0329672, WO2008/054828, US8252538); lung cancer cells (WO2011/076143, WO2013/033640, WO2009/070653, US2010/0323357); cutaneous T cell lymphoma (WO2013/011378); colorectal cancer cells (WO2011/0281756, WO2011/076142); cancer positive lymph nodes (WO2009/100430, US2009/0263803); nasopharyngeal carcinoma

(EP2112235); chronic obstructive pulmonary disease (US2012/0264626, US2013/0053263); thyroid cancer (WO2013/066678); ovarian cancer cells (US2012/0309645, WO2011/095623); breast cancer cells (WO2008/154098, WO2007/081740, US2012/0214699), leukemia and lymphoma (WO2008/073915, US2009/0092974, US2012/0316081, US2012/0283310, WO2010/018563, the content of each of which is incorporated herein by reference in its entirety).

[00494] As a non-limiting example, miRNA binding sites for miRNAs that are over-expressed in certain cancer and/or tumor cells can be removed from the 3'UTR of a polyribonucleotide of the disclosure, restoring the expression suppressed by the over-expressed miRNAs in cancer cells, thus ameliorating the corresponsive biological function, for instance, transcription stimulation and/or repression, cell cycle arrest, apoptosis and cell death. Normal cells and tissues, wherein miRNAs expression is not up-regulated, will remain unaffected.

[00495] MiRNA can also regulate complex biological processes such as angiogenesis (e.g., miR-132) (Anand and Cheresch Curr Opin Hematol 2011 18:171-176). In the polyribonucleotides of the disclosure, miRNA binding sites that are involved in such processes can be removed or introduced, in order to tailor the expression of the polyribonucleotides to biologically relevant cell types or relevant biological processes. In this context, the polyribonucleotides of the disclosure are defined as auxotrophic polyribonucleotides.

Stem Loops

[00496] Polynucleotides (e.g., mRNAs) may include a stem loop such as, but not limited to, a histone stem loop. The stem loop may be a nucleotide sequence that is about 25 or about 26 nucleotides in length such as, but not limited to, those as described in International Patent Publication No. WO2013/103659, which is incorporated herein by reference. The histone stem loop may be located 3'-relative to the coding region (e.g., at the 3'-terminus of the coding region). As a non-limiting example, the stem loop may be located at the 3'-end of a polynucleotide described herein. In some cases, a polynucleotide (e.g., an mRNA) includes more than one stem loop (e.g., two stem loops). Examples of stem loop sequences are described in International Patent Publication Nos. WO2012/019780 and WO201502667, the stem loop sequences of which are herein incorporated by reference. In some instances, a polynucleotide includes the stem loop sequence CAAAGGCTCTTTTCAGAGCCACCA (SEQ ID NO: 1). In

others, a polynucleotide includes the stem loop sequence

CAAAGGCUCUUUCAGAGCCACCA (SEQ ID NO: 2).

[00497] A stem loop may be located in a second terminal region of a polynucleotide. As a non-limiting example, the stem loop may be located within an untranslated region (*e.g.*, 3'-UTR) in a second terminal region.

[00498] In some cases, a polynucleotide such as, but not limited to mRNA, which includes the histone stem loop may be stabilized by the addition of a 3'-stabilizing region (*e.g.*, a 3'-stabilizing region including at least one chain terminating nucleoside). Not wishing to be bound by theory, the addition of at least one chain terminating nucleoside may slow the degradation of a polynucleotide and thus can increase the half-life of the polynucleotide.

[00499] In other cases, a polynucleotide such as, but not limited to mRNA, which includes the histone stem loop may be stabilized by an alteration to the 3'-region of the polynucleotide that can prevent and/or inhibit the addition of oligio(U) (see *e.g.*, International Patent Publication No. WO2013/103659).

[00500] In yet other cases, a polynucleotide such as, but not limited to mRNA, which includes the histone stem loop may be stabilized by the addition of an oligonucleotide that terminates in a 3'-deoxynucleoside, 2',3'-dideoxynucleoside 3'-O- methylnucleosides, 3'-O-ethylnucleosides, 3'-arabinosides, and other alternative nucleosides known in the art and/or described herein.

[00501] In some instances, the polynucleotides of the present disclosure may include a histone stem loop, a poly-A region, and/or a 5'-cap structure. The histone stem loop may be before and/or after the poly-A region. The polynucleotides including the histone stem loop and a poly-A region sequence may include a chain terminating nucleoside described herein.

[00502] In other instances, the polynucleotides of the present disclosure may include a histone stem loop and a 5'-cap structure. The 5'-cap structure may include, but is not limited to, those described herein and/or known in the art.

[00503] In some cases, the conserved stem loop region may include a miR sequence described herein. As a non-limiting example, the stem loop region may include the seed sequence of a miR sequence described herein. In another non-limiting example, the stem loop region may include a miR-122 seed sequence.

[00504] In certain instances, the conserved stem loop region may include a miR sequence described herein and may also include a TEE sequence.

[00505] In some cases, the incorporation of a miR sequence and/or a TEE sequence changes the shape of the stem loop region which may increase and/or decrease translation. (See, e.g., Kedde et al. A Pumilio-induced RNA structure switch in p27-3'UTR controls miR-221 and miR-22 accessibility. *Nature Cell Biology*. 2010, herein incorporated by reference in its entirety).

[00506] Polynucleotides may include at least one histone stem-loop and a poly-A region or polyadenylation signal. Non-limiting examples of polynucleotide sequences encoding for at least one histone stem-loop and a poly-A region or a polyadenylation signal are described in International Patent Publication No. WO2013/120497, WO2013/120629, WO2013/120500, WO2013/120627, WO2013/120498, WO2013/120626, WO2013/120499 and WO2013/120628, the sequences of each of which are incorporated herein by reference. In certain cases, the polynucleotide encoding for a histone stem loop and a poly-A region or a polyadenylation signal may code for a pathogen antigen or fragment thereof such as the polynucleotide sequences described in International Patent Publication No WO2013/120499 and WO2013/120628, the sequences of both of which are incorporated herein by reference. In other cases, the polynucleotide encoding for a histone stem loop and a poly-A region or a polyadenylation signal may code for a therapeutic protein such as the polynucleotide sequences described in International Patent Publication No WO2013/120497 and WO2013/120629, the sequences of both of which are incorporated herein by reference. In some cases, the polynucleotide encoding for a histone stem loop and a poly-A region or a polyadenylation signal may code for a tumor antigen or fragment thereof such as the polynucleotide sequences described in International Patent Publication No WO2013/120500 and WO2013/120627, the sequences of both of which are incorporated herein by reference. In other cases, the polynucleotide encoding for a histone stem loop and a poly-A region or a polyadenylation signal may code for an allergenic antigen or an autoimmune self-antigen such as the polynucleotide sequences described in International Patent Publication No WO2013/120498 and WO2013/120626, the sequences of each of which is incorporated herein by reference in its entirety.

Poly-A Regions

[00507] A polynucleotide or nucleic acid (e.g., an mRNA) may include a polyA sequence and/or polyadenylation signal. A polyA sequence may be comprised entirely or mostly of

adenine nucleotides or analogs or derivatives thereof. A polyA sequence may be a tail located adjacent to a 3' untranslated region of a nucleic acid.

[00508] During RNA processing, a long chain of adenosine nucleotides (poly-A region) is normally added to messenger RNA (mRNA) molecules to increase the stability of the molecule. Immediately after transcription, the 3'-end of the transcript is cleaved to free a 3'-hydroxy. Then poly-A polymerase adds a chain of adenosine nucleotides to the RNA. The process, called polyadenylation, adds a poly-A region that is between 100 and 250 residues long.

[00509] Unique poly-A region lengths may provide certain advantages to the alternative polynucleotides of the present disclosure.

[00510] Generally, the length of a poly-A region of the present disclosure is at least 30 nucleotides in length. In another embodiment, the poly-A region is at least 35 nucleotides in length. In another embodiment, the length is at least 40 nucleotides. In another embodiment, the length is at least 45 nucleotides. In another embodiment, the length is at least 55 nucleotides. In another embodiment, the length is at least 60 nucleotides. In another embodiment, the length is at least 70 nucleotides. In another embodiment, the length is at least 80 nucleotides. In another embodiment, the length is at least 90 nucleotides. In another embodiment, the length is at least 100 nucleotides. In another embodiment, the length is at least 120 nucleotides. In another embodiment, the length is at least 140 nucleotides. In another embodiment, the length is at least 160 nucleotides. In another embodiment, the length is at least 180 nucleotides. In another embodiment, the length is at least 200 nucleotides. In another embodiment, the length is at least 250 nucleotides. In another embodiment, the length is at least 300 nucleotides. In another embodiment, the length is at least 350 nucleotides. In another embodiment, the length is at least 400 nucleotides. In another embodiment, the length is at least 450 nucleotides. In another embodiment, the length is at least 500 nucleotides. In another embodiment, the length is at least 600 nucleotides. In another embodiment, the length is at least 700 nucleotides. In another embodiment, the length is at least 800 nucleotides. In another embodiment, the length is at least 900 nucleotides. In another embodiment, the length is at least 1000 nucleotides. In another embodiment, the length is at least 1100 nucleotides. In another embodiment, the length is at least 1200 nucleotides. In another embodiment, the length is at least 1300 nucleotides. In another embodiment, the length is at least 1400 nucleotides. In another embodiment, the length is at least 1500 nucleotides. In another embodiment, the length is at least 1600 nucleotides. In

another embodiment, the length is at least 1700 nucleotides. In another embodiment, the length is at least 1800 nucleotides. In another embodiment, the length is at least 1900 nucleotides. In another embodiment, the length is at least 2000 nucleotides. In another embodiment, the length is at least 2500 nucleotides. In another embodiment, the length is at least 3000 nucleotides.

[00511] In some instances, the poly-A region may be 80 nucleotides, 120 nucleotides, 160 nucleotides in length on an alternative polynucleotide molecule described herein.

[00512] In other instances, the poly-A region may be 20, 40, 80, 100, 120, 140 or 160 nucleotides in length on an alternative polynucleotide molecule described herein.

[00513] In some cases, the poly-A region is designed relative to the length of the overall alternative polynucleotide. This design may be based on the length of the coding region of the alternative polynucleotide, the length of a particular feature or region of the alternative polynucleotide (such as mRNA), or based on the length of the ultimate product expressed from the alternative polynucleotide. When relative to any feature of the alternative polynucleotide (*e.g.*, other than the mRNA portion which includes the poly-A region) the poly-A region may be 10, 20, 30, 40, 50, 60, 70, 80, 90 or 100% greater in length than the additional feature. The poly-A region may also be designed as a fraction of the alternative polynucleotide to which it belongs. In this context, the poly-A region may be 10, 20, 30, 40, 50, 60, 70, 80, or 90% or more of the total length of the construct or the total length of the construct minus the poly-A region.

[00514] In certain cases, engineered binding sites and/or the conjugation of polynucleotides (*e.g.*, mRNA) for poly-A binding protein may be used to enhance expression. The engineered binding sites may be sensor sequences which can operate as binding sites for ligands of the local microenvironment of the polynucleotides (*e.g.*, mRNA). As a non-limiting example, the polynucleotides (*e.g.*, mRNA) may include at least one engineered binding site to alter the binding affinity of poly-A binding protein (PABP) and analogs thereof. The incorporation of at least one engineered binding site may increase the binding affinity of the PABP and analogs thereof.

[00515] Additionally, multiple distinct polynucleotides (*e.g.*, mRNA) may be linked together to the PABP (poly-A binding protein) through the 3'-end using alternative nucleotides at the 3'-terminus of the poly-A region. Transfection experiments can be conducted in relevant cell lines at and protein production can be assayed by ELISA at 12 hours, 24 hours, 48 hours, 72 hours, and day 7 post-transfection. As a non-limiting example, the transfection experiments may be

used to evaluate the effect on PABP or analogs thereof binding affinity as a result of the addition of at least one engineered binding site.

[00516] In certain cases, a poly-A region may be used to modulate translation initiation.

While not wishing to be bound by theory, the poly-A region recruits PABP which in turn can interact with translation initiation complex and thus may be essential for protein synthesis.

[00517] In some cases, a poly-A region may also be used in the present disclosure to protect against 3'-5'-exonuclease digestion.

[00518] In some instances, a polynucleotide (*e.g.*, mRNA) may include a polyA-G Quartet. The G-quartet is a cyclic hydrogen bonded array of four guanosine nucleotides that can be formed by G-rich sequences in both DNA and RNA. In this embodiment, the G-quartet is incorporated at the end of the poly-A region. The resultant polynucleotides (*e.g.*, mRNA) may be assayed for stability, protein production and other parameters including half-life at various time points. It has been discovered that the polyA-G quartet results in protein production equivalent to at least 75% of that seen using a poly-A region of 120 nucleotides alone.

[00519] In some cases, a polynucleotide (*e.g.*, mRNA) may include a poly-A region and may be stabilized by the addition of a 3'-stabilizing region. The polynucleotides (*e.g.*, mRNA) with a poly-A region may further include a 5'-cap structure.

[00520] In other cases, a polynucleotide (*e.g.*, mRNA) may include a poly-A-G Quartet. The polynucleotides (*e.g.*, mRNA) with a poly-A-G Quartet may further include a 5'-cap structure.

[00521] In some cases, the 3'-stabilizing region which may be used to stabilize a polynucleotide (*e.g.*, mRNA) including a poly-A region or poly-A-G Quartet may be, but is not limited to, those described in International Patent Publication No. WO2013/103659, the poly-A regions and poly-A-G Quartets of which are incorporated herein by reference. In other cases, the 3'-stabilizing region which may be used with the present disclosure include a chain termination nucleoside such as 3'-deoxyadenosine (cordycepin), 3'-deoxyuridine, 3'-deoxycytosine, 3'-deoxyguanosine, 3'-deoxythymine, 2',3'-dideoxynucleosides, such as 2',3'-dideoxyadenosine, 2',3'-dideoxyuridine, 2',3'-dideoxycytosine, 2',3'-dideoxyguanosine, 2',3'-dideoxythymine, a 2'-deoxynucleoside, or an O-methylnucleoside.

[00522] In other cases, a polynucleotide such as, but not limited to mRNA, which includes a polyA region or a poly-A-G Quartet may be stabilized by an alteration to the 3'-region of the

polynucleotide that can prevent and/or inhibit the addition of oligio(U) (see *e.g.*, International Patent Publication No. WO2013/103659).

[00523] In yet other instances, a polynucleotide such as, but not limited to mRNA, which includes a poly-A region or a poly-A-G Quartet may be stabilized by the addition of an oligonucleotide that terminates in a 3'-deoxynucleoside, 2',3'-dideoxynucleoside 3'-O-methylnucleosides, 3'-O-ethylnucleosides, 3'-arabinosides, and other alternative nucleosides known in the art and/or described herein.

Chain Terminating Nucleosides

[00524] A nucleic acid may include a chain terminating nucleoside. In some embodiments, a chain terminating nucleoside may include those nucleosides deoxygenated at the 2' and/or 3' positions of their sugar group. Such species may include 3'-deoxyadenosine (cordycepin), 3'-deoxyuridine, 3'-deoxycytosine, 3'-deoxyguanosine, 3'-deoxythymine, and 2',3'-dideoxynucleosides, such as 2',3'-dideoxyadenosine, 2',3'-dideoxyuridine, 2',3'-dideoxycytosine, 2',3'-dideoxyguanosine, and 2',3'-dideoxythymine.

Genome Editing Techniques

[00525] In some embodiments, the nucleic acid is suitable for a genome editing technique.

[00526] In some embodiments, the genome editing technique is clustered regularly interspaced short palindromic repeats (CRISPR) or transcription activator-like effector nuclease (TALEN).

[00527] In some embodiments, the nucleic acid is at least one nucleic acid suitable for a genome editing technique selected from the group consisting of a CRISPR RNA (crRNA), a trans-activating crRNA (tracrRNA), a single guide RNA (sgRNA), and a DNA repair template.

Vaccines

[00528] In some embodiments, the therapeutic and/or prophylactic is a ribonucleic acid (RNA) cancer vaccine of an RNA (*e.g.*, messenger RNA (mRNA)) that can safely direct the body's cellular machinery to produce nearly any cancer protein or fragment thereof of interest. In some embodiments, the RNA is a modified RNA. The RNA vaccines of the present disclosure may be used to induce a balanced immune response against cancers, comprising both cellular and humoral immunity, without risking the possibility of insertional mutagenesis, for example.

[00529] The RNA vaccines may be utilized in various settings depending on the prevalence of the cancer or the degree or level of unmet medical need. The RNA vaccines may be utilized to treat and/or prevent a cancer of various stages or degrees of metastasis. The RNA vaccines have superior properties in that they produce much larger antibody titers and produce responses earlier than alternative anti-cancer therapies including cancer vaccines. While not wishing to be bound by theory, it is believed that the RNA vaccines, as mRNA polynucleotides, are better designed to produce the appropriate protein conformation upon translation as the RNA vaccines co-opt natural cellular machinery. Unlike traditional vaccines which are manufactured *ex vivo* and may trigger unwanted cellular responses, the RNA vaccines are presented to the cellular system in a more native fashion.

[00530] Some embodiments of the present disclosure provide cancer vaccines that include at least one ribonucleic acid (RNA) polynucleotide having an open reading frame encoding at least one cancer antigenic polypeptide or an immunogenic fragment thereof {e.g., an immunogenic fragment capable of inducing an immune response to cancer). Other embodiments include at least one ribonucleic acid (RNA) polynucleotide having an open reading frame encoding two or more antigens or epitopes capable of inducing an immune response to cancer.

[00531] The invention in some aspects is a vaccine of an mRNA having an open reading frame encoding a cancer antigen and a mRNA having an open reading frame encoding an immune checkpoint modulator. In some embodiments the immune checkpoint modulator is an inhibitory checkpoint polypeptide. In some embodiments, the inhibitory checkpoint polypeptide is an antibody or fragment thereof that specifically binds to a molecule selected from the group consisting of PD-1, TIM-3, VISTA, A2AR, B7-H3, B7-H4, BTLA, CTLA-4, IDO, KIR and LAG3. The inhibitory checkpoint polypeptide is an anti-CTLA4 or anti-PD1 antibody in some embodiments. Optionally the vaccine includes a lipid nanoparticle. In some embodiments a vaccine of a mRNA having an open reading frame encoding a cancer antigen is administered to a subject. In some embodiments a checkpoint inhibitor 3-10 weeks later. In some embodiments the checkpoint inhibitor is administered 4 weeks later.

[00532] In some aspects the invention is a personalized cancer vaccine of a mRNA having an open reading frame encoding at least 2 cancer antigens, wherein the at least 2 cancer antigens are patient specific cancer antigens, and a lipid nanoparticle carrier. In some embodiments the lipid nanoparticle has a mean diameter of 50-200 nm.

[00533] In some aspects, the invention is a personalized cancer vaccine of a mRNA having an open reading frame encoding at least 2 cancer antigens wherein the at least 2 cancer antigens are representative of antigens of a patient. In some embodiments, the antigens of a patient are exosome identified antigens of the patient. In some embodiments a single mRNA encodes the cancer antigens. In some embodiments a plurality of mRNA encode the cancer antigens.

[00534] Each mRNA may encode 5-10 cancer antigens or a single cancer antigen in some embodiments. In some embodiments the mRNA encodes 2-100 cancer antigens. In some embodiments mRNA encodes 10-100, 20-100, 50-100, 100-200, 300-400, 500-600, 600-700, 700-800, 900-1,000, or 1,000-10,000 cancer antigens.

[00535] In some embodiments,

- a) the mRNA encoding each cancer antigen is interspersed by cleavage sensitive sites;
- b) the mRNA encoding each cancer antigen is linked directly to one another without a linker ;
- c) the mRNA encoding each cancer antigen is linked to one another with a single nucleotide linker;
- d) each cancer antigen comprises a 25-35 amino acids and includes a centrally located SNP mutation;
- e) at least 30% of the cancer antigens have a highest affinity for class I MHC molecules from the subject;
- f) at least 30% of the cancer antigens have a highest affinity for class II MHC molecules from the subject;
- g) at least 50% of the cancer antigens have a predicted binding affinity of $IC_{50} > 500nM$ for HLA-A, HLA-B and/or DRB 1;
- h) the mRNA encodes 20 cancer antigens;
- i) 50% of the cancer antigens have a binding affinity for class I MHC and 50% of the cancer antigens have a binding affinity for class II MHC; and/or
- j) the mRNA encoding the cancer antigens is arranged such that the cancer antigens are ordered to minimize pseudo-epitopes.

[00536] In some embodiments, each cancer antigen comprises 31 amino acids and includes a centrally located SNP mutation with 15 flanking amino acids on each side of the SNP mutation.

[00537] In some embodiments the vaccine is a personalized cancer vaccine and wherein the cancer antigen is a subject specific cancer antigen. In some embodiments, the subject specific

cancer antigen may be representative of an exome of a tumor sample of the subject, or of a transcriptome of a tumor sample of the subject. In some embodiments, the subject specific cancer antigen may be representative of an exosome of the subject.

[00538] In some embodiments, the open reading frame further encodes one or more traditional cancer antigens. In some embodiments, the traditional cancer antigen is a non-mutated antigen. In some embodiments, the traditional cancer antigen is a mutated antigen.

[00539] In some embodiments, the mRNA vaccine further comprises an mRNA having an open reading frame encoding one or more traditional cancer antigens.

[00540] In some embodiments a single mRNA encodes the cancer antigens. In some embodiments a plurality of mRNA encode the cancer antigens. Each cancer antigen is 10-50 amino acids in length in some embodiments. In some embodiments each cancer antigen is 15- 20 amino acids in length. In some embodiments the cancer antigen is 20-50, 25-100, 100-200, 200-300, 300-400, 400-500, 500-1,000, or 1,000-10,000 amino acids in length.

[00541] In some embodiments, the vaccines further comprise an adjuvant.

[00542] Some embodiments of the present disclosure provide a cancer vaccine that includes at least one ribonucleic acid (RNA) polynucleotide having an open reading frame encoding at least one cancer polypeptide, at least one 5' terminal cap and at least one chemical modification, formulated within a lipid nanoparticle. In some embodiments, a 5' terminal cap is 7mG(5')ppp(5')NlmpNp.

[00543] In some embodiments, at least one chemical modification is selected from pseudouridine, N1-methylpseudouridine, N1-ethylpseudouridine, 2-thiouridine, 4'- thiouridine, 5-methylcytosine, 2-thio-1 -methyl- 1-deaza-pseudouridine, 2-thio-1-methyl- pseudouridine, 2-thio-5-aza-uridine , 2-thio-dihydropseudouridine, 2-thio-dihydrouridine, 2- thio-pseudouridine, 4-methoxy-2-thio-pseudouridine, 4-methoxy-pseudouridine, 4-thio-1- methyl-pseudouridine, 4-thio-pseudouridine, 5-aza-uridine, dihydropseudouridine, 5- methyluridine, 5-methoxyuridine and 2' -O-methyl uridine. In some embodiments the extent of incorporation of chemically modified nucleotides has been optimized for improved immune responses to the vaccine formulation.

[00544] In some embodiments, a lipid nanoparticle comprises a cationic lipid, a PEG-modified lipid, a sterol and a non-cationic lipid. In some embodiments, a cationic lipid is an ionizable cationic lipid and the non-cationic lipid is a neutral lipid, and the sterol is a cholesterol.

In some embodiments, a cationic lipid is selected from 2,2-dilinoleyl-4-dimethylaminoethyl-[1,3]-dioxolane (DLin-KC2-DMA), dilinoleyl-methyl-4-dimethylaminobutyrate (DLin-MC3-DMA), and di((Z)-non-2-en-1-yl) 9-((4-(dimethylamino)butanoyl)oxy)heptadecanedioate (L319).

[00545] In some embodiments the lipid nanoparticle formulation includes an immune potentiator (e.g., TLR agonist) to enhance immunogenicity of the vaccine (formulation).

[00546] In some embodiments, 100% of the uracil in the open reading frame have a chemical modification. In some embodiments, a chemical modification is in the 5-position of the uracil. In some embodiments, a chemical modification is a N1-methyl pseudouridine.

[00547] In some embodiments a mRNA encoding an APC reprogramming molecule is included in the vaccine or coadministered with the vaccine. The APC reprogramming molecule may be a CIITA, a chaperone protein such as CLIP, HLA-DO, HLA-DM, a costimulatory molecule such as CD40, CD80, CD86, a CIITA fragment such as amino acids 26-137 of CIITA or a protein having 80% sequence identity to CIITA.

[00548] In other aspects a method of eliciting an immune response in a subject by identifying at least 2 cancer antigens from a sample of a subject, wherein the at least 2 cancer antigens include mutations selected from the group consisting of frame-shift mutations and recombinations, and administering a mRNA vaccine having an open reading frame encoding the at least 2 cancer antigens to the subject is provided.

[00549] In some embodiments, the cancer antigens are identified from an exosome of the subject. In some embodiments 2-100 antigens are identified from the exosome. In some embodiments the mRNA vaccine has an open reading frame encoding the 2-100 antigens. A single mRNA or a plurality of mRNA may encode the antigens.

[00550] In some embodiments the antigens are cancer antigens. The cancer antigens may have mutations selected from point mutations, frame-shift mutations and recombinations. The method may further involve confirming that the cancer antigens are subject specific by exome analysis.

[00551] In some embodiments the method may further involve confirming that the cancer antigens are subject specific by transcriptome analysis.

[00552] In some embodiments the method also involves at least one month after the administration of the mRNA vaccine, identifying at least 2 cancer antigens from a sample of the subject to produce a second set of cancer antigens, and administering to the subject a mRNA vaccine having an open reading frame encoding the second set of cancer antigens to the subject.

[00553] In some embodiments the sample of the subject is a tumor sample.

[00554] In other aspects the invention comprises a method of eliciting an immune response in a subject by identifying at least 2 cancer antigens from a sample of a subject to produce a first set of cancer antigens, administering to the subject a mRNA vaccine having an open reading frame encoding the first set of cancer antigens to the subject, at least one month after the administration of the mRNA vaccine, identifying at least 2 cancer antigens from a sample of a subject to produce a second set of cancer antigens, and administering to the subject a mRNA vaccine having an open reading frame encoding the second set of cancer antigens to the subject.

[00555] The mRNA vaccine having an open reading frame encoding second set of antigens, in some embodiments, is administered to the subject 6 months to 1 year after the mRNA vaccine having an open reading frame encoding first set of cancer antigens. In some embodiments the mRNA vaccine having an open reading frame encoding second set of antigens is administered to the subject 1-2 years after the mRNA vaccine having an open reading frame encoding first set of cancer antigens.

[00556] In some embodiments a single mRNA has an open reading frame encoding the cancer antigens. In some embodiments a plurality of mRNA encode the antigens. In some embodiments the second set of cancer antigens includes 2-100 antigens. In some embodiments the cancer antigens have mutations selected from point mutations, frame-shift mutations and recombinations.

[00557] In other aspects the invention comprises a method of eliciting an immune response in a subject, by identifying at least 2 cancer antigens from a sample of a subject, administering a mRNA having an open reading frame encoding the at least 2 cancer antigens to the subject, and administering a cancer therapeutic agent to the subject. In some embodiments the cancer therapeutic agent is a targeted therapy. The targeted therapy may be a BRAF inhibitor such as vemurafenib (PLX4032) or dabrafenib.

[00558] In some embodiments the cancer therapeutic agent is a T-cell therapeutic agent. The T-cell therapeutic agent may be a checkpoint inhibitor such as an anti-PD- 1 antibody or an anti-CTLA-4 antibody. In some embodiments the anti-PD- 1 antibody is BMS-936558 (nivolumab). In some embodiments the anti-CTLA-4 antibody is ipilimumab. The T-cell therapeutic agent in some embodiments is OX40L. In some embodiments the cancer therapeutic agent is a vaccine comprising a population based tumor specific antigen.

[00559] In some embodiments the cancer therapeutic agent is a vaccine comprising an mRNA having an open reading frame encoding one or more traditional cancer antigens.

[00560] In some embodiments, the mRNA having an open reading frame encoding the at least 2 cancer antigens is administered to the subject simultaneously with the cancer therapeutic agent. In some embodiments, the mRNA having an open reading frame encoding the at least 2 cancer antigens is administered to the subject before administration of the cancer therapeutic agent. In some embodiments, the mRNA having an open reading frame encoding the at least 2 cancer antigens is administered to the subject after administration of the cancer therapeutic agent.

[00561] A method comprising mixing a mRNA having an open reading frame encoding a cancer antigen with a lipid nanoparticle formulation to produce a mRNA cancer vaccine, and administering the mRNA cancer vaccine to a subject within 24 hours of mixing is provided in other aspects of the invention. In some embodiments the mRNA cancer vaccine is administered to the subject within 12 hours of mixing. In some embodiments the mRNA cancer vaccine is administered to the subject within 1 hour of mixing. The mRNA cancer vaccine encodes 2-100 cancer antigens or 10-100 cancer antigens in some embodiments.

[00562] In some embodiments the vaccine is a personalized cancer vaccine and wherein the cancer antigen is a subject specific cancer antigen.

[00563] In some embodiments a single mRNA encodes the cancer antigens. In some embodiments a plurality of mRNA encode the cancer antigens. Each mRNA encodes 5-10 cancer antigens or a single cancer antigen in some embodiments. In some embodiments each cancer antigen is 10-50 amino acids in length or 15-20 amino acids in length.

[00564] Further provided herein are uses of cancer vaccines in the manufacture of a medicament for use in a method of inducing an antigen specific immune response in a subject, the method comprising administering the cancer vaccine to the subject in an amount effective to produce an antigen specific immune response.

[00565] A method of treating cancer in a subject in need thereof by identifying at least 2 cancer antigens from an exosome isolated from the subject; producing, based on the identified antigens, a mRNA vaccine having an open reading frame encoding the antigens; and administering the mRNA vaccine to the subject, wherein the mRNA vaccine induces a tumor-specific immune response in the subject, thereby treating cancer in the subject is provided in other aspects. The invention in other aspects is a RNA vaccine preparable according to a method

involving identifying at least 2 cancer antigens from an exosome isolated from a subject; producing, based on the identified antigens, a mRNA vaccine having an open reading frame encoding the antigens.

[00566] A method of eliciting an immune response in a subject against a cancer antigen is provided in aspects of the invention. The method involves administering to the subject a RNA vaccine comprising at least one RNA polynucleotide having an open reading frame encoding at least one antigenic polypeptide or an immunogenic fragment thereof, thereby inducing in the subject an immune response specific to the antigenic polypeptide or an immunogenic fragment thereof, wherein the anti-antigenic polypeptide antibody titer in the subject is increased following vaccination relative to anti-antigenic polypeptide antibody titer in a subject vaccinated with a prophylactically effective dose of a traditional vaccine against the cancer. An "anti-antigenic polypeptide antibody" is a serum antibody the binds specifically to the antigenic polypeptide.

[00567] A prophylactically effective dose is a therapeutically effective dose that prevents advancement of cancer at a clinically acceptable level. In some embodiments the therapeutically effective dose is a dose listed in a package insert for the vaccine. A traditional vaccine, as used herein, refers to a vaccine other than the mRNA vaccines of the invention. For instance, a traditional vaccine includes but is not limited to live microorganism vaccines, killed microorganism vaccines, subunit vaccines, protein antigen vaccines, DNA vaccines, etc. In exemplary embodiments, a traditional vaccine is a vaccine that has achieved regulatory approval and/or is registered by a national drug regulatory body, for example the Food and Drug Administration (FDA) in the United States or the European Medicines Agency (EMA.)

[00568] In some embodiments the anti-antigenic polypeptide antibody titer in the subject is increased 1 log to 10 log following vaccination relative to anti-antigenic polypeptide antibody titer in a subject vaccinated with a prophylactically effective dose of a traditional vaccine against the cancer.

[00569] In some embodiments the anti-antigenic polypeptide antibody titer in the subject is increased 1 log following vaccination relative to anti-antigenic polypeptide antibody titer in a subject vaccinated with a prophylactically effective dose of a traditional vaccine against the cancer.

[00570] In some embodiments the anti-antigenic polypeptide antibody titer in the subject is increased 2 log following vaccination relative to anti-antigenic polypeptide antibody titer in a subject vaccinated with a prophylactically effective dose of a traditional vaccine against the cancer.

[00571] In some embodiments the anti-antigenic polypeptide antibody titer in the subject is increased 3 log following vaccination relative to anti-antigenic polypeptide antibody titer in a subject vaccinated with a prophylactically effective dose of a traditional vaccine against the cancer.

[00572] In some embodiments the anti-antigenic polypeptide antibody titer in the subject is increased 5 log following vaccination relative to anti-antigenic polypeptide antibody titer in a subject vaccinated with a prophylactically effective dose of a traditional vaccine against the or cancer.

[00573] In some embodiments the anti-antigenic polypeptide antibody titer in the subject is increased 10 log following vaccination relative to anti-antigenic polypeptide antibody titer in a subject vaccinated with a prophylactically effective dose of a traditional vaccine against the or cancer.

[00574] A method of eliciting an immune response in a subject against a cancer antigen is provided in other aspects of the invention. The method involves administering to the subject a RNA vaccine comprising at least one RNA polynucleotide having an open reading frame encoding at least one antigenic polypeptide or an immunogenic fragment thereof, thereby inducing in the subject an immune response specific to antigenic polypeptide or an immunogenic fragment thereof, wherein the immune response in the subject is equivalent to an immune response in a subject vaccinated with a traditional vaccine against the cancer antigen at 2 times to 100 times the dosage level relative to the RNA vaccine.

[00575] In some embodiments the immune response in the subject is equivalent to an immune response in a subject vaccinated with a traditional vaccine at twice the dosage level relative to the RNA vaccine.

[00576] In some embodiments the immune response in the subject is equivalent to an immune response in a subject vaccinated with a traditional vaccine at three times the dosage level relative to the RNA vaccine.

[00577] In some embodiments the immune response in the subject is equivalent to an immune response in a subject vaccinated with a traditional vaccine at 4 times the dosage level relative to the RNA vaccine.

[00578] In some embodiments the immune response in the subject is equivalent to an immune response in a subject vaccinated with a traditional vaccine at 5 times the dosage level relative to the RNA vaccine. In some embodiments the immune response in the subject is equivalent to an immune response in a subject vaccinated with a traditional vaccine at 10 times the dosage level relative to the RNA vaccine.

[00579] In some embodiments the immune response in the subject is equivalent to an immune response in a subject vaccinated with a traditional vaccine at 50 times the dosage level relative to the RNA vaccine.

[00580] In some embodiments the immune response in the subject is equivalent to an immune response in a subject vaccinated with a traditional vaccine at 100 times the dosage level relative to the RNA vaccine.

[00581] In some embodiments the immune response in the subject is equivalent to an immune response in a subject vaccinated with a traditional vaccine at 10 times to 1000 times the dosage level relative to the RNA vaccine.

[00582] In some embodiments the immune response in the subject is equivalent to an immune response in a subject vaccinated with a traditional vaccine at 100 times to 1000 times the dosage level relative to the RNA vaccine.

[00583] In some embodiments the immune response is assessed by determining antibody titer in the subject.

[00584] In other aspects the invention comprises a method of eliciting an immune response in a subject against a by administering to the subject a RNA vaccine comprising at least one RNA polynucleotide having an open reading frame encoding at least one cancer antigenic polypeptide or an immunogenic fragment thereof, thereby inducing in the subject an immune response specific to the antigenic polypeptide or an immunogenic fragment thereof, wherein the immune response in the subject is induced 2 days to 10 weeks earlier relative to an immune response induced in a subject vaccinated with a prophylactically effective dose of a traditional vaccine against the cancer antigen. In some embodiments the immune response in the subject is induced

in a subject vaccinated with a prophylactically effective dose of a traditional vaccine at 2 times to 100 times the dosage level relative to the RNA vaccine.

[00585] In some embodiments the immune response in the subject is induced 2 days earlier relative to an immune response induced in a subject vaccinated with a prophylactically effective dose of a traditional vaccine.

[00586] In some embodiments the immune response in the subject is induced 3 days earlier relative to an immune response induced in a subject vaccinated a prophylactically effective dose of a traditional vaccine. In some embodiments the immune response in the subject is induced 1 week earlier relative to an immune response induced in a subject vaccinated with a prophylactically effective dose of a traditional vaccine.

[00587] In some embodiments the immune response in the subject is induced 2 weeks earlier relative to an immune response induced in a subject vaccinated with a prophylactically effective dose of a traditional vaccine.

[00588] In some embodiments the immune response in the subject is induced 3 weeks earlier relative to an immune response induced in a subject vaccinated with a prophylactically effective dose of a traditional vaccine.

[00589] In some embodiments the immune response in the subject is induced 5 weeks earlier relative to an immune response induced in a subject vaccinated with a prophylactically effective dose of a traditional vaccine.

[00590] In some embodiments the immune response in the subject is induced 10 weeks earlier relative to an immune response induced in a subject vaccinated with a prophylactically effective dose of a traditional vaccine.

[00591] A method of eliciting an immune response in a subject against an cancer by administering to the subject a cancer RNA vaccine having an open reading frame encoding a first antigenic polypeptide, wherein the RNA polynucleotide does not include a stabilization element, and wherein an adjuvant is not coformulated or co-administered with the vaccine.

[00592] In yet other aspects the invention comprises a method of producing an mRNA encoding a concatemeric cancer antigen comprising between 1000 and 3000 nucleotides, the method by

- (a) binding a first polynucleotide comprising an open reading frame encoding the concatemeric cancer antigen and a second polynucleotide comprising a 5'-UTR to a polynucleotide conjugated to a solid support;
- (b) ligating the 3'-terminus of the second polynucleotide to the 5'-terminus of the first polynucleotide under suitable conditions, wherein the suitable conditions comprise a DNA Ligase, thereby producing a first ligation product;
- (c) ligating the 5' terminus of a third polynucleotide comprising a 3'-UTR to the 3'-terminus of the first ligation product under suitable conditions, wherein the suitable conditions comprise an RNA Ligase, thereby producing a second ligation product; and
- (d) releasing the second ligation product from the solid support, thereby producing an mRNA encoding the concatemeric cancer antigen comprising between 1000 and 3000 nucleotides. In some embodiments of any one of the provided compositions or methods the mRNA encodes one or more recurrent polymorphisms. In some embodiments, the one or more recurrent polymorphisms comprises a recurrent somatic cancer mutation in p53. In some such embodiments, the one or more recurrent somatic cancer mutation in p53 are selected from the group consisting of:
- (1) mutations at the canonical 5' splice site neighboring codon p.T125;
 - (2) mutations at the canonical 5' splice site neighboring codon p.331;
 - (3) mutations at the canonical 3' splice site neighboring codon p.126;
 - (4) mutations at the canonical 5' splice site neighboring codon p.224, inducing a cryptic alternative intronic 5' splice site.

[00593] In some embodiments, the invention provides a cancer therapeutic vaccine comprising mRNA encoding an open reading frame (ORF) coding for one or more of neoantigen peptides (1) through (4). In some embodiments, the invention provides the selective administration of a vaccine containing or coding for one or more of peptides (1)-(4), based on the patient's tumor containing any of the above mutations. In some embodiments, the invention provides the selective administration of the vaccine based on the dual criteria of the subject's tumor containing any of the above mutations and the subject's normal HLA type containing the corresponding HLA allele predicted to bind to the resulting neoantigen.

[00594] A method for treating a subject with a personalized mRNA cancer vaccine, by isolating a sample from a subject, identifying a set of neoepitopes by analyzing a patient

transcriptome and/or a patient exome from the sample to produce a patient specific mutanome, selecting a set of neoepitopes for the vaccine from the mutanome based on MHC binding strength, MHC binding diversity, predicted degree of immunogenicity, low self-reactivity, and/or T cell reactivity, preparing the mRNA vaccine to encode the set of neoepitopes and administering the mRNA vaccine to the subject within two months of isolating the sample from the subject is provided in other aspects of the invention. In some embodiments the mRNA vaccine is administered to the subject within one month of isolating the sample from the subject.

[00595] In other aspects the invention comprises a method of identifying a set of neoepitopes for use in a personalized mRNA cancer vaccine having one or more polynucleotides that encode the set of neoepitopes by a. identifying a patient specific mutanome by analyzing a patient transcriptome and a patient exome, b. selecting a subset of 15-500 neoepitopes from the mutanome using a weighted value for the neoepitopes based on at least three of: an assessment of gene or transcript-level expression in patient RNA-seq; variant call confidence score; RNA-seq allele-specific expression; conservative vs. non-conservative amino acid substitution; position of point mutation (Centering Score for increased TCR engagement); position of point mutation (Anchoring Score for differential HLA binding); Selfness: <100% core epitope homology with patient WES data; HLA-A and -B IC50 for 8mers-11mers; HLA-DRB 1 IC50 for 15mers-20mers; promiscuity Score (i.e. number of patient HLAs predicted to bind); HLA-C IC50 for 8mers-11mers; HLA-DRB3-5 IC50 for 15mers-20mers; HLA-DQB 1/A1 IC50 for 15mers-20mers; HLA-DPB 1/A1 IC50 for 15mers-20mers; Class I vs Class II proportion; Diversity of patient HLA-A, -B and DRB 1 allotypes covered; proportion of point mutation vs complex epitopes (e.g. frameshifts); and /or pseudo-epitope HLA binding scores, and c. selecting the set of neoepitopes for use in a personalized mRNA cancer vaccine from the subset based on the highest weighted value, wherein the set of neoepitopes comprise 15-40 neoepitopes.

[00596] In some embodiments the nucleic acid vaccines described herein are chemically modified. In some embodiments the nucleic acid vaccines are unmodified.

[00597] Some aspects provide compositions for and methods of vaccinating a subject comprising administering to the subject a nucleic acid vaccine comprising one or more RNA polynucleotides having an open reading frame encoding a first antigenic polypeptide or a concatemeric polypeptide, wherein the RNA polynucleotide does not include a stabilization element, and wherein an adjuvant is not coformulated or co-administered with the vaccine.

[00598] In other aspects the invention is a composition for or method of vaccinating a subject comprising administering to the subject a nucleic acid vaccine comprising one or more RNA polynucleotides having an open reading frame encoding a first antigenic polypeptide wherein a dosage of between 10 ug/kg and 400 ug/kg of the nucleic acid vaccine is administered to the subject. In some embodiments the dosage of the RNA polynucleotide is 1-5 ug, 5-10 ug, 10-15 ug, 15-20 ug, 10-25 ug, 20-25 ug, 20-50 ug, 30-50 ug, 40-50 ug, 40-60 ug, 60-80 ug, 60-100 ug, 50-100 ug, 80-120 ug, 40-120 ug, 40-150 ug, 50-150 ug, 50-200 ug, 80-200 ug, 100-200 ug, 120-250 ug, 150-250 ug, 180-280 ug, 200-300 ug, 50-300 ug, 80-300 ug, 100-300 ug, 40-300 ug, 50-350 ug, 100-350 ug, 200-350 ug, 300-350 ug, 320-400 ug, 40-380 ug, 40-100 ug, 100-400 ug, 200-400 ug, or 300-400 ug per dose. In some embodiments, the nucleic acid vaccine is administered to the subject by intradermal or intramuscular injection. In some embodiments, the nucleic acid vaccine is administered to the subject on day zero. In some embodiments, a second dose of the nucleic acid vaccine is administered to the subject on day twenty one.

[00599] In some embodiments, a dosage of 25 micrograms of the RNA polynucleotide is included in the nucleic acid vaccine administered to the subject. In some embodiments, a dosage of 100 micrograms of the RNA polynucleotide is included in the nucleic acid vaccine administered to the subject. In some embodiments, a dosage of 50 micrograms of the RNA polynucleotide is included in the nucleic acid vaccine administered to the subject. In some embodiments, a dosage of 75 micrograms of the RNA polynucleotide is included in the nucleic acid vaccine administered to the subject. In some embodiments, a dosage of 150 micrograms of the RNA polynucleotide is included in the nucleic acid vaccine administered to the subject. In some embodiments, a dosage of 400 micrograms of the RNA polynucleotide is included in the nucleic acid vaccine administered to the subject. In some embodiments, a dosage of 200 micrograms of the RNA polynucleotide is included in the nucleic acid vaccine administered to the subject. In some embodiments, the RNA polynucleotide accumulates at a 100 fold higher level in the local lymph node in comparison with the distal lymph node. In some embodiments the nucleic acid vaccine is chemically modified and in some embodiments the nucleic acid vaccine is not chemically modified.

[00600] Aspects of the invention provide a nucleic acid vaccine comprising one or more RNA polynucleotides having an open reading frame encoding a first antigenic polypeptide or a concatemeric polypeptide, wherein the RNA polynucleotide does not include a stabilization

element, and a pharmaceutically acceptable carrier or excipient, wherein an adjuvant is not included in the vaccine. In some embodiments, the stabilization element is a histone stem-loop. In some embodiments, the stabilization element is a nucleic acid sequence having increased GC content relative to wild type sequence.

[00601] Aspects of the invention provide nucleic acid vaccines comprising one or more RNA polynucleotides having an open reading frame encoding a first antigenic polypeptide, wherein the RNA polynucleotide is present in the formulation for in vivo administration to a host, which confers an antibody titer superior to the criterion for seroprotection for the first antigen for an acceptable percentage of human subjects. In some embodiments, the antibody titer produced by the mRNA vaccines of the invention is a neutralizing antibody titer. In some embodiments the neutralizing antibody titer is greater than a protein vaccine. In some embodiments the neutralizing antibody titer produced by the mRNA vaccines of the invention is greater than an adjuvanted protein vaccine. In some embodiments the neutralizing antibody titer produced by the mRNA vaccines of the invention is 1,000- 10,000, 1,200- 10,000, 1,400- 10,000, 1,500- 10,000, 1,000- 5,000, 1,000- 4,000, 1,800- 10,000, 2000-10,000, 2,000- 5,000, 2,000- 3,000, 2,000- 4,000, 3,000- 5,000, 3,000- 4,000, or 2,000- 2,500. A neutralization titer is typically expressed as the highest serum dilution required to achieve a 50% reduction in the number of plaques.

[00602] In preferred aspects, vaccines of the invention (e.g., LNP-encapsulated mRNA vaccines) produce prophylactically- and/or therapeutically efficacious levels, concentrations and/or titers of antigen-specific antibodies in the blood or serum of a vaccinated subject. As defined herein, the term antibody titer refers to the amount of antigen-specific antibody produced in a subject, e.g., a human subject. In exemplary embodiments, antibody titer is expressed as the inverse of the greatest dilution (in a serial dilution) that still gives a positive result. In exemplary embodiments, antibody titer is determined or measured by enzyme-linked immunosorbent assay (ELISA). In exemplary embodiments, antibody titer is determined or measured by neutralization assay, e.g., by microneutralization assay. In certain aspects, antibody titer measurement is expressed as a ratio, such as 1:40, 1: 100, etc.

[00603] In exemplary embodiments of the invention, an efficacious vaccine produces an antibody titer of greater than 1:40, greater than 1: 100, greater than 1:400, greater than 1: 1000, greater than 1:2000, greater than 1:3000, greater than 1:4000, greater than 1:500, greater than 1:6000, greater than 1:7500, greater than 1: 10000. In exemplary embodiments, the antibody titer

is produced or reached by 10 days following vaccination, by 20 days following vaccination, by 30 days following vaccination, by 40 days following vaccination, or by 50 or more days following vaccination. In exemplary embodiments, the titer is produced or reached following a single dose of vaccine administered to the subject. In some embodiments, the titer is produced or reached following multiple doses, e.g., following a first and a second dose (e.g., a booster dose.)

[00604] In exemplary aspects of the invention, antigen-specific antibodies are measured in units of $\mu\text{g/ml}$ or are measured in units of IU/L (International Units per liter) or mIU/ml (milli International Units per ml). In exemplary embodiments of the invention, an efficacious vaccine produces $>0.5 \mu\text{g/ml}$, $>0.1 \mu\text{g/ml}$, $>0.2 \mu\text{g/ml}$, $>0.35 \mu\text{g/ml}$, $>0.5 \mu\text{g/ml}$, $>1 \mu\text{g/ml}$, $>2 \mu\text{g/ml}$, $>5 \mu\text{g/ml}$ or $>10 \mu\text{g/ml}$. In exemplary embodiments of the invention, an efficacious vaccine produces $>10 \text{ mIU/ml}$, $>20 \text{ mIU/ml}$, $>50 \text{ mIU/ml}$, $>100 \text{ mIU/ml}$, $>200 \text{ mIU/ml}$, $>500 \text{ mIU/ml}$ or $>1000 \text{ mIU/ml}$. In exemplary embodiments, the antibody level or concentration is produced or reached by 10 days following vaccination, by 20 days following vaccination, by 30 days following vaccination, by 40 days following vaccination, or by 50 or more days following vaccination. In exemplary embodiments, the level or concentration is produced or reached following a single dose of vaccine administered to the subject. In some embodiments, the level or concentration is produced or reached following multiple doses, e.g., following a first and a second dose (e.g., a booster dose.) In exemplary embodiments, antibody level or concentration is determined or measured by enzyme-linked immunosorbent assay (ELISA). In exemplary embodiments, antibody level or concentration is determined or measured by neutralization assay, e.g., by microneutralization assay. Also provided are nucleic acid vaccines comprising one or more RNA polynucleotides having an open reading frame encoding a first antigenic polypeptide or a concatemeric polypeptide, wherein the RNA polynucleotide is present in a formulation for in vivo administration to a host for eliciting a longer lasting high antibody titer than an antibody titer elicited by an mRNA vaccine having a stabilizing element or formulated with an adjuvant and encoding the first antigenic polypeptide. In some embodiments, the RNA polynucleotide is formulated to produce neutralizing antibodies within one week of a single administration. In some embodiments, the adjuvant is selected from a cationic peptide and an immunostimulatory nucleic acid. In some embodiments, the cationic peptide is protamine.

[00605] Aspects provide nucleic acid vaccines comprising one or more RNA polynucleotides having an open reading frame comprising at least one chemical modification or optionally no

nucleotide modification, the open reading frame encoding a first antigenic polypeptide or a concatemeric polypeptide, wherein the RNA polynucleotide is present in the formulation for in vivo administration to a host such that the level of antigen expression in the host significantly exceeds a level of antigen expression produced by an mRNA vaccine having a stabilizing element or formulated with an adjuvant and encoding the first antigenic polypeptide.

[00606] Other aspects provide nucleic acid vaccines comprising one or more RNA polynucleotides having an open reading frame comprising at least one chemical modification or optionally no nucleotide modification, the open reading frame encoding a first antigenic polypeptide or a concatemeric polypeptide, wherein the vaccine has at least 10 fold less RNA polynucleotide than is required for an unmodified mRNA vaccine to produce an equivalent antibody titer. In some embodiments, the RNA polynucleotide is present in a dosage of 25- 100 micrograms.

[00607] Aspects of the invention also provide a unit of use vaccine, comprising between 10ug and 400 ug of one or more RNA polynucleotides having an open reading frame comprising at least one chemical modification or optionally no nucleotide modification, the open reading frame encoding a first antigenic polypeptide or a concatemeric polypeptide, and a pharmaceutically acceptable carrier or excipient, formulated for delivery to a human subject. In some embodiments, the vaccine further comprises a cationic lipid nanoparticle.

[00608] Aspects of the invention provide methods of creating, maintaining or restoring antigenic memory to a tumor in an individual or population of individuals comprising administering to said individual or population an antigenic memory booster nucleic acid vaccine comprising (a) at least one RNA polynucleotide, said polynucleotide comprising at least one chemical modification or optionally no nucleotide modification and two or more codon-optimized open reading frames, said open reading frames encoding a set of reference antigenic polypeptides, and (b) optionally a pharmaceutically acceptable carrier or excipient. In some embodiments, the vaccine is administered to the individual via a route selected from the group consisting of intramuscular administration, intradermal administration and subcutaneous administration. In some embodiments, the administering step comprises contacting a muscle tissue of the subject with a device suitable for injection of the composition. In some embodiments, the administering step comprises contacting a muscle tissue of the subject with a device suitable for injection of the composition in combination with electroporation.

[00609] Aspects of the invention provide methods of vaccinating a subject comprising administering to the subject a single dosage of between 25 ug/kg and 400 ug/kg of a nucleic acid vaccine comprising one or more RNA polynucleotides having an open reading frame encoding a first antigenic polypeptide or a concatemeric polypeptide in an effective amount to vaccinate the subject.

[00610] Other aspects provide nucleic acid vaccines comprising one or more RNA polynucleotides having an open reading frame comprising at least one chemical modification, the open reading frame encoding a first antigenic polypeptide or a concatemeric polypeptide, wherein the vaccine has at least 10 fold less RNA polynucleotide than is required for an unmodified mRNA vaccine to produce an equivalent antibody titer. In some embodiments, the RNA polynucleotide is present in a dosage of 25-100 micrograms.

[00611] Other aspects provide nucleic acid vaccines comprising an LNP formulated RNA polynucleotide having an open reading frame comprising no nucleotide modifications (unmodified), the open reading frame encoding a first antigenic polypeptide or a concatemeric polypeptide, wherein the vaccine has at least 10 fold less RNA polynucleotide than is required for an unmodified mRNA vaccine not formulated in a LNP to produce an equivalent antibody titer. In some embodiments, the RNA polynucleotide is present in a dosage of 25-100 micrograms.

[00612] In other aspects the invention encompasses a method of treating an elderly subject age 60 years or older comprising administering to the subject a nucleic acid vaccine comprising one or more RNA polynucleotides having an open reading frame encoding an antigenic polypeptide or a concatemeric polypeptide in an effective amount to vaccinate the subject.

[00613] In other aspects the invention encompasses a method of treating a young subject age 17 years or younger comprising administering to the subject a nucleic acid vaccine comprising one or more RNA polynucleotides having an open reading frame encoding an antigenic polypeptide or a concatemeric polypeptide in an effective amount to vaccinate the subject.

[00614] In other aspects the invention encompasses a method of treating an adult subject comprising administering to the subject a nucleic acid vaccine comprising one or more RNA polynucleotides having an open reading frame encoding an antigenic polypeptide or a concatemeric polypeptide in an effective amount to vaccinate the subject.

[00615] In some aspects the invention comprises a method of vaccinating a subject with a combination vaccine including at least two nucleic acid sequences encoding antigens wherein the dosage for the vaccine is a combined therapeutic dosage wherein the dosage of each individual nucleic acid encoding an antigen is a sub therapeutic dosage. In some embodiments, the combined dosage is 25 micrograms of the RNA polynucleotide in the nucleic acid vaccine administered to the subject. In some embodiments, the combined dosage is 100 micrograms of the RNA polynucleotide in the nucleic acid vaccine administered to the subject. In some embodiments the combined dosage is 50 micrograms of the RNA polynucleotide in the nucleic acid vaccine administered to the subject. In some embodiments, the combined dosage is 75 micrograms of the RNA polynucleotide in the nucleic acid vaccine administered to the subject. In some embodiments, the combined dosage is 150 micrograms of the RNA polynucleotide in the nucleic acid vaccine administered to the subject. In some embodiments, the combined dosage is 400 micrograms of the RNA polynucleotide in the nucleic acid vaccine administered to the subject. In some embodiments, the sub therapeutic dosage of each individual nucleic acid encoding an antigen is 1, 2, 3, 4, 5, 6, 7, 8, 9, 10, 11, 12, 13, 14, 15, 16, 17, 18, 19, or 20 micrograms. In some embodiments the nucleic acid vaccine is chemically modified and in some embodiments the nucleic acid vaccine is not chemically modified.

Other Components

[00616] A LNP may include one or more components in addition to those described in the preceding sections. In some embodiments, a LNP may include one or more small hydrophobic molecules such as a vitamin (*e.g.*, vitamin A or vitamin E) and/or a sterol.

[00617] Lipid nanoparticles may also include one or more permeability enhancer molecules, carbohydrates, polymers, surface altering agents, or other components. A permeability enhancer molecule may be a molecule described by U.S. patent application publication No. 2005/0222064, the contents of which is incorporated herein by reference in its entirety. Carbohydrates may include simple sugars (*e.g.*, glucose) and polysaccharides (*e.g.*, glycogen and derivatives and analogs thereof).

[00618] A polymer may be included in and/or used to encapsulate or partially encapsulate a LNP. A polymer may be biodegradable and/or biocompatible. A polymer may be selected from, but is not limited to, polyamines, polyethers, polyamides, polyesters, polycarbamates, polyureas,

polycarbonates, polystyrenes, polyimides, polysulfones, polyurethanes, polyacetylenes, polyethylenes, polyethyleneimines, polyisocyanates, polyacrylates, polymethacrylates, polyacrylonitriles, and polyarylates. In some embodiments, a polymer may include poly(caprolactone) (PCL), ethylene vinyl acetate polymer (EVA), poly(lactic acid) (PLA), poly(L-lactic acid) (PLLA), poly(glycolic acid) (PGA), poly(lactic acid-co-glycolic acid) (PLGA), poly(L-lactic acid-co-glycolic acid) (PLLGA), poly(D,L-lactide) (PDLA), poly(L-lactide) (PLLA), poly(D,L-lactide-co-caprolactone), poly(D,L-lactide-co-caprolactone-co-glycolide), poly(D,L-lactide-co-PEO-co-D,L-lactide), poly(D,L-lactide-co-PPO-co-D,L-lactide), polyalkyl cyanoacrylate, polyurethane, poly-L-lysine (PLL), hydroxypropyl methacrylate (HPMA), polyethyleneglycol, poly-L-glutamic acid, poly(hydroxy acids), polyanhydrides, polyorthoesters, poly(ester amides), polyamides, poly(ester ethers), polycarbonates, polyalkylenes such as polyethylene and polypropylene, polyalkylene glycols such as poly(ethylene glycol) (PEG), polyalkylene oxides (PEO), polyalkylene terephthalates such as poly(ethylene terephthalate), polyvinyl alcohols (PVA), polyvinyl ethers, polyvinyl esters such as poly(vinyl acetate), polyvinyl halides such as poly(vinyl chloride) (PVC), polyvinylpyrrolidone (PVP), polysiloxanes, polystyrene, polyurethanes, derivatized celluloses such as alkyl celluloses, hydroxyalkyl celluloses, cellulose ethers, cellulose esters, nitro celluloses, hydroxypropylcellulose, carboxymethylcellulose, polymers of acrylic acids, such as poly(methyl(meth)acrylate) (PMMA), poly(ethyl(meth)acrylate), poly(butyl(meth)acrylate), poly(isobutyl(meth)acrylate), poly(hexyl(meth)acrylate), poly(isodecyl(meth)acrylate), poly(lauryl(meth)acrylate), poly(phenyl(meth)acrylate), poly(methyl acrylate), poly(isopropyl acrylate), poly(isobutyl acrylate), poly(octadecyl acrylate) and copolymers and mixtures thereof, polydioxanone and its copolymers, polyhydroxyalkanoates, polypropylene fumarate, polyoxymethylene, poloxamers, poloxamines, poly(ortho)esters, poly(butyric acid), poly(valeric acid), poly(lactide-co-caprolactone), trimethylene carbonate, poly(*N*-acryloylmorpholine) (PACM), poly(2-methyl-2-oxazoline) (PMOX), poly(2-ethyl-2-oxazoline) (PEOZ), and polyglycerol.

[00619] Surface altering agents may include, but are not limited to, anionic proteins (*e.g.*, bovine serum albumin), surfactants (*e.g.*, cationic surfactants such as dimethyldioctadecyl-ammonium bromide), sugars or sugar derivatives (*e.g.*, cyclodextrin), nucleic acids, polymers (*e.g.*, heparin, polyethylene glycol, and poloxamer), mucolytic agents (*e.g.*, acetylcysteine,

mugwort, bromelain, papain, clerodendrum, bromhexine, carbocisteine, eprazinone, mesna, ambroxol, sobrerol, domiodol, letosteine, stepronin, tiopronin, gelsolin, thymosin β 4, dornase alfa, neltenexine, and erdosteine), and DNases (*e.g.*, rhDNase). A surface altering agent may be disposed within a nanoparticle and/or on the surface of a LNP (*e.g.*, by coating, adsorption, covalent linkage, or other process).

[00620] A LNP may also comprise one or more functionalized lipids. In some embodiments, a lipid may be functionalized with an alkyne group that, when exposed to an azide under appropriate reaction conditions, may undergo a cycloaddition reaction. In particular, a lipid bilayer may be functionalized in this fashion with one or more groups useful in facilitating membrane permeation, cellular recognition, or imaging. The surface of a LNP may also be conjugated with one or more useful antibodies. Functional groups and conjugates useful in targeted cell delivery, imaging, and membrane permeation are well known in the art.

[00621] In addition to these components, lipid nanoparticles may include any substance useful in pharmaceutical compositions. In some embodiments, the lipid nanoparticle may include one or more pharmaceutically acceptable excipients or accessory ingredients such as, but not limited to, one or more solvents, dispersion media, diluents, dispersion aids, suspension aids, granulating aids, disintegrants, fillers, glidants, liquid vehicles, binders, surface active agents, isotonic agents, thickening or emulsifying agents, buffering agents, lubricating agents, oils, preservatives, and other species. Excipients such as waxes, butters, coloring agents, coating agents, flavorings, and perfuming agents may also be included. Pharmaceutically acceptable excipients are well known in the art (see for example Remington's *The Science and Practice of Pharmacy*, 21st Edition, A. R. Gennaro; Lippincott, Williams & Wilkins, Baltimore, MD, 2006).

[00622] Examples of diluents may include, but are not limited to, calcium carbonate, sodium carbonate, calcium phosphate, dicalcium phosphate, calcium sulfate, calcium hydrogen phosphate, sodium phosphate lactose, sucrose, cellulose, microcrystalline cellulose, kaolin, mannitol, sorbitol, inositol, sodium chloride, dry starch, cornstarch, powdered sugar, and/or combinations thereof. Granulating and dispersing agents may be selected from the non-limiting list consisting of potato starch, corn starch, tapioca starch, sodium starch glycolate, clays, alginic acid, guar gum, citrus pulp, agar, bentonite, cellulose and wood products, natural sponge, cation-exchange resins, calcium carbonate, silicates, sodium carbonate, cross-linked poly(vinyl-pyrrolidone) (crospovidone), sodium carboxymethyl starch (sodium starch glycolate),

carboxymethyl cellulose, cross-linked sodium carboxymethyl cellulose (croscarmellose), methylcellulose, pregelatinized starch (starch 1500), microcrystalline starch, water insoluble starch, calcium carboxymethyl cellulose, magnesium aluminum silicate (VEEGUM®), sodium lauryl sulfate, quaternary ammonium compounds, and/or combinations thereof.

[00623] Surface active agents and/or emulsifiers may include, but are not limited to, natural emulsifiers (e.g., acacia, agar, alginic acid, sodium alginate, tragacanth, chondrux, cholesterol, xanthan, pectin, gelatin, egg yolk, casein, wool fat, cholesterol, wax, and lecithin), colloidal clays (e.g., bentonite [aluminum silicate] and VEEGUM® [magnesium aluminum silicate]), long chain amino acid derivatives, high molecular weight alcohols (e.g., stearyl alcohol, cetyl alcohol, oleyl alcohol, triacetin monostearate, ethylene glycol distearate, glyceryl monostearate, and propylene glycol monostearate, polyvinyl alcohol), carbomers (e.g., carboxy polymethylene, polyacrylic acid, acrylic acid polymer, and carboxyvinyl polymer), carrageenan, cellulosic derivatives (e.g., carboxymethylcellulose sodium, powdered cellulose, hydroxymethyl cellulose, hydroxypropyl cellulose, hydroxypropyl methylcellulose, methylcellulose), sorbitan fatty acid esters (e.g., polyoxyethylene sorbitan monolaurate [TWEEN®20], polyoxyethylene sorbitan [TWEEN® 60], polyoxyethylene sorbitan monooleate [TWEEN®80], sorbitan monopalmitate [SPAN®40], sorbitan monostearate [SPAN®60], sorbitan tristearate [SPAN®65], glyceryl monooleate, sorbitan monooleate [SPAN®80]), polyoxyethylene esters (e.g., polyoxyethylene monostearate [MYRJ® 45], polyoxyethylene hydrogenated castor oil, polyethoxylated castor oil, polyoxymethylene stearate, and SOLUTOL®), sucrose fatty acid esters, polyethylene glycol fatty acid esters (e.g., CREMOPHOR®), polyoxyethylene ethers, (e.g., polyoxyethylene lauryl ether [BRIJ® 30]), poly(vinyl-pyrrolidone), diethylene glycol monolaurate, triethanolamine oleate, sodium oleate, potassium oleate, ethyl oleate, oleic acid, ethyl laurate, sodium lauryl sulfate, PLURONIC®F 68, POLOXAMER® 188, cetrimonium bromide, cetylpyridinium chloride, benzalkonium chloride, docusate sodium, and/or combinations thereof.

[00624] A binding agent may be starch (e.g., cornstarch and starch paste); gelatin; sugars (e.g., sucrose, glucose, dextrose, dextrin, molasses, lactose, lactitol, mannitol); natural and synthetic gums (e.g., acacia, sodium alginate, extract of Irish moss, panwar gum, ghatti gum, mucilage of isapol husks, carboxymethylcellulose, methylcellulose, ethylcellulose, hydroxyethylcellulose, hydroxypropyl cellulose, hydroxypropyl methylcellulose, microcrystalline cellulose, cellulose acetate, poly(vinyl-pyrrolidone), magnesium aluminum

silicate (VEEGUM®), and larch arabogalactan); alginates; polyethylene oxide; polyethylene glycol; inorganic calcium salts; silicic acid; polymethacrylates; waxes; water; alcohol; and combinations thereof, or any other suitable binding agent.

[00625] Examples of preservatives may include, but are not limited to, antioxidants, chelating agents, antimicrobial preservatives, antifungal preservatives, alcohol preservatives, acidic preservatives, and/or other preservatives. Examples of antioxidants include, but are not limited to, alpha tocopherol, ascorbic acid, ascorbyl palmitate, butylated hydroxyanisole, butylated hydroxytoluene, monothioglycerol, potassium metabisulfite, propionic acid, propyl gallate, sodium ascorbate, sodium bisulfite, sodium metabisulfite, and/or sodium sulfite. Examples of chelating agents include ethylenediaminetetraacetic acid (EDTA), citric acid monohydrate, disodium edetate, dipotassium edetate, edetic acid, fumaric acid, malic acid, phosphoric acid, sodium edetate, tartaric acid, and/or trisodium edetate. Examples of antimicrobial preservatives include, but are not limited to, benzalkonium chloride, benzethonium chloride, benzyl alcohol, bronopol, cetrimide, cetylpyridinium chloride, chlorhexidine, chlorobutanol, chlorocresol, chloroxylenol, cresol, ethyl alcohol, glycerin, hexetidine, imidurea, phenol, phenoxyethanol, phenylethyl alcohol, phenylmercuric nitrate, propylene glycol, and/or thimerosal. Examples of antifungal preservatives include, but are not limited to, butyl paraben, methyl paraben, ethyl paraben, propyl paraben, benzoic acid, hydroxybenzoic acid, potassium benzoate, potassium sorbate, sodium benzoate, sodium propionate, and/or sorbic acid. Examples of alcohol preservatives include, but are not limited to, ethanol, polyethylene glycol, benzyl alcohol, phenol, phenolic compounds, bisphenol, chlorobutanol, hydroxybenzoate, and/or phenylethyl alcohol. Examples of acidic preservatives include, but are not limited to, vitamin A, vitamin C, vitamin E, beta-carotene, citric acid, acetic acid, dehydroascorbic acid, ascorbic acid, sorbic acid, and/or phytic acid. Other preservatives include, but are not limited to, tocopherol, tocopherol acetate, deteroxime mesylate, cetrimide, butylated hydroxyanisole (BHA), butylated hydroxytoluene (BHT), ethylenediamine, sodium lauryl sulfate (SLS), sodium lauryl ether sulfate (SLES), sodium bisulfite, sodium metabisulfite, potassium sulfite, potassium metabisulfite, GLYDANT PLUS®, PHENONIP®, methylparaben, GERMALL® 115, GERMABEN®II, NEOLONE™, KATHON™, and/or EUXYL®.

[00626] Examples of buffering agents include, but are not limited to, citrate buffer solutions, acetate buffer solutions, phosphate buffer solutions, ammonium chloride, calcium carbonate,

calcium chloride, calcium citrate, calcium gluconate, calcium gluceptate, calcium gluconate, d-gluconic acid, calcium glycerophosphate, calcium lactate, calcium lactobionate, propanoic acid, calcium levulinate, pentanoic acid, dibasic calcium phosphate, phosphoric acid, tribasic calcium phosphate, calcium hydroxide phosphate, potassium acetate, potassium chloride, potassium gluconate, potassium mixtures, dibasic potassium phosphate, monobasic potassium phosphate, potassium phosphate mixtures, sodium acetate, sodium bicarbonate, sodium chloride, sodium citrate, sodium lactate, dibasic sodium phosphate, monobasic sodium phosphate, sodium phosphate mixtures, tromethamine, amino-sulfonate buffers (*e.g.*, HEPES), magnesium hydroxide, aluminum hydroxide, alginic acid, pyrogen-free water, isotonic saline, Ringer's solution, ethyl alcohol, and/or combinations thereof. Lubricating agents may selected from the non-limiting group consisting of magnesium stearate, calcium stearate, stearic acid, silica, talc, malt, glyceryl behenate, hydrogenated vegetable oils, polyethylene glycol, sodium benzoate, sodium acetate, sodium chloride, leucine, magnesium lauryl sulfate, sodium lauryl sulfate, and combinations thereof.

[00627] Examples of oils include, but are not limited to, almond, apricot kernel, avocado, babassu, bergamot, black current seed, borage, cade, camomile, canola, caraway, carnauba, castor, cinnamon, cocoa butter, coconut, cod liver, coffee, corn, cotton seed, emu, eucalyptus, evening primrose, fish, flaxseed, geraniol, gourd, grape seed, hazel nut, hyssop, isopropyl myristate, jojoba, kukui nut, lavandin, lavender, lemon, litsea cubeba, macademia nut, mallow, mango seed, meadowfoam seed, mink, nutmeg, olive, orange, orange roughly, palm, palm kernel, peach kernel, peanut, poppy seed, pumpkin seed, rapeseed, rice bran, rosemary, safflower, sandalwood, sasquana, savoury, sea buckthorn, sesame, shea butter, silicone, soybean, sunflower, tea tree, thistle, tsubaki, vetiver, walnut, and wheat germ oils as well as butyl stearate, caprylic triglyceride, capric triglyceride, cyclomethicone, diethyl sebacate, dimethicone 360, simethicone, isopropyl myristate, mineral oil, octyldodecanol, oleyl alcohol, silicone oil, and/or combinations thereof.

Pharmaceutical compositions

[00628] Formulations comprising lipid nanoparticles may be formulated in whole or in part as pharmaceutical compositions. Pharmaceutical compositions may include one or more lipid nanoparticles. In some embodiments, a pharmaceutical composition may include one or more

lipid nanoparticles including one or more different therapeutics and/or prophylactics.

Pharmaceutical compositions may further include one or more pharmaceutically acceptable excipients or accessory ingredients such as those described herein. General guidelines for the formulation and manufacture of pharmaceutical compositions and agents are available, for example, in Remington's *The Science and Practice of Pharmacy*, 21st Edition, A. R. Gennaro; Lippincott, Williams & Wilkins, Baltimore, MD, 2006. Conventional excipients and accessory ingredients may be used in any pharmaceutical composition, except insofar as any conventional excipient or accessory ingredient may be incompatible with one or more components of a LNP in the formulation of the disclosure. An excipient or accessory ingredient may be incompatible with a component of a LNP of the formulation if its combination with the component or LNP may result in any undesirable biological effect or otherwise deleterious effect.

[00629] In some embodiments, one or more excipients or accessory ingredients may make up greater than 50% of the total mass or volume of a pharmaceutical composition including a LNP. In some embodiments, the one or more excipients or accessory ingredients may make up 50%, 60%, 70%, 80%, 90%, or more of a pharmaceutical convention. In some embodiments, a pharmaceutically acceptable excipient is at least 95%, at least 96%, at least 97%, at least 98%, at least 99%, or 100% pure. In some embodiments, an excipient is approved for use in humans and for veterinary use. In some embodiments, an excipient is approved by United States Food and Drug Administration. In some embodiments, an excipient is pharmaceutical grade. In some embodiments, an excipient meets the standards of the United States Pharmacopoeia (USP), the European Pharmacopoeia (EP), the British Pharmacopoeia, and/or the International Pharmacopoeia.

[00630] Relative amounts of the one or more lipid nanoparticles, the one or more pharmaceutically acceptable excipients, and/or any additional ingredients in a pharmaceutical composition in accordance with the present disclosure will vary, depending upon the identity, size, and/or condition of the subject treated and further depending upon the route by which the composition is to be administered. By way of example, a pharmaceutical composition may comprise between 0.1% and 100% (wt/wt) of one or more lipid nanoparticles. As another example, a pharmaceutical composition may comprise between 0.1% and 15% (wt/vol) of one or more amphiphilic polymers (e.g., 0.5%, 1%, 2.5%, 5%, 10%, or 12.5% w/v).

[00631] In some embodiments, the lipid nanoparticles and/or pharmaceutical compositions of the disclosure are refrigerated or frozen for storage and/or shipment (e.g., being stored at a temperature of 4 °C or lower, such as a temperature between about -150 °C and about 0 °C or between about -80 °C and about -20 °C (e.g., about -5 °C, -10 °C, -15 °C, -20 °C, -25 °C, -30 °C, -40 °C, -50 °C, -60 °C, -70 °C, -80 °C, -90 °C, -130 °C or -150 °C). For example, the pharmaceutical composition comprising one or more lipid nanoparticles is a solution or solid (e.g., via lyophilization) that is refrigerated for storage and/or shipment at, for example, about -20 °C, -30 °C, -40 °C, -50 °C, -60 °C, -70 °C, or -80 °C. In certain embodiments, the disclosure also relates to a method of increasing stability of the lipid nanoparticles and by storing the lipid nanoparticles and/or pharmaceutical compositions thereof at a temperature of 4 °C or lower, such as a temperature between about -150 °C and about 0 °C or between about -80 °C and about -20 °C, e.g., about -5 °C, -10 °C, -15 °C, -20 °C, -25 °C, -30 °C, -40 °C, -50 °C, -60 °C, -70 °C, -80 °C, -90 °C, -130 °C or -150 °C).

[00632] Lipid nanoparticles and/or pharmaceutical compositions including one or more lipid nanoparticles may be administered to any patient or subject, including those patients or subjects that may benefit from a therapeutic effect provided by the delivery of a therapeutic and/or prophylactic to one or more particular cells, tissues, organs, or systems or groups thereof, such as the renal system. Although the descriptions provided herein of lipid nanoparticles and pharmaceutical compositions including lipid nanoparticles are principally directed to compositions which are suitable for administration to humans, it will be understood by the skilled artisan that such compositions are generally suitable for administration to any other mammal. Modification of compositions suitable for administration to humans in order to render the compositions suitable for administration to various animals is well understood, and the ordinarily skilled veterinary pharmacologist can design and/or perform such modification with merely ordinary, if any, experimentation. Subjects to which administration of the compositions is contemplated include, but are not limited to, humans, other primates, and other mammals, including commercially relevant mammals such as cattle, pigs, horses, sheep, cats, dogs, mice, and/or rats.

[00633] A pharmaceutical composition including one or more lipid nanoparticles may be prepared by any method known or hereafter developed in the art of pharmacology. In general, such preparatory methods include bringing the active ingredient into association with an

excipient and/or one or more other accessory ingredients, and then, if desirable or necessary, dividing, shaping, and/or packaging the product into a desired single- or multi-dose unit.

[00634] A pharmaceutical composition in accordance with the present disclosure may be prepared, packaged, and/or sold in bulk, as a single unit dose, and/or as a plurality of single unit doses. As used herein, a “unit dose” is discrete amount of the pharmaceutical composition comprising a predetermined amount of the active ingredient (*e.g.*, lipid nanoparticle). The amount of the active ingredient is generally equal to the dosage of the active ingredient which would be administered to a subject and/or a convenient fraction of such a dosage such as, for example, one-half or one-third of such a dosage.

[00635] Pharmaceutical compositions may be prepared in a variety of forms suitable for a variety of routes and methods of administration. In some embodiments, pharmaceutical compositions may be prepared in liquid dosage forms (*e.g.*, emulsions, microemulsions, nanoemulsions, solutions, suspensions, syrups, and elixirs), injectable forms, solid dosage forms (*e.g.*, capsules, tablets, pills, powders, and granules), dosage forms for topical and/or transdermal administration (*e.g.*, ointments, pastes, creams, lotions, gels, powders, solutions, sprays, inhalants, and patches), suspensions, powders, and other forms.

[00636] Liquid dosage forms for oral and parenteral administration include, but are not limited to, pharmaceutically acceptable emulsions, microemulsions, nanoemulsions, solutions, suspensions, syrups, and/or elixirs. In addition to active ingredients, liquid dosage forms may comprise inert diluents commonly used in the art such as, for example, water or other solvents, solubilizing agents and emulsifiers such as ethyl alcohol, isopropyl alcohol, ethyl carbonate, ethyl acetate, benzyl alcohol, benzyl benzoate, propylene glycol, 1,3-butylene glycol, dimethylformamide, oils (in particular, cottonseed, groundnut, corn, germ, olive, castor, and sesame oils), glycerol, tetrahydrofurfuryl alcohol, polyethylene glycols and fatty acid esters of sorbitan, and mixtures thereof. Besides inert diluents, oral compositions can include additional therapeutics and/or prophylactics, additional agents such as wetting agents, emulsifying and suspending agents, sweetening, flavoring, and/or perfuming agents. In certain embodiments for parenteral administration, compositions are mixed with solubilizing agents such as Cremophor[®], alcohols, oils, modified oils, glycols, polysorbates, cyclodextrins, polymers, and/or combinations thereof.

[00637] Injectable preparations, for example, sterile injectable aqueous or oleaginous suspensions may be formulated according to the known art using suitable dispersing agents, wetting agents, and/or suspending agents. Sterile injectable preparations may be sterile injectable solutions, suspensions, and/or emulsions in nontoxic parenterally acceptable diluents and/or solvents, for example, as a solution in 1,3-butanediol. Among the acceptable vehicles and solvents that may be employed are water, Ringer's solution, U.S.P., and isotonic sodium chloride solution. Sterile, fixed oils are conventionally employed as a solvent or suspending medium. For this purpose any bland fixed oil can be employed including synthetic mono- or diglycerides. Fatty acids such as oleic acid can be used in the preparation of injectables.

[00638] Injectable formulations can be sterilized, for example, by filtration through a bacterial-retaining filter, and/or by incorporating sterilizing agents in the form of sterile solid compositions which can be dissolved or dispersed in sterile water or other sterile injectable medium prior to use.

[00639] In order to prolong the effect of an active ingredient, it is often desirable to slow the absorption of the active ingredient from subcutaneous or intramuscular injection. This may be accomplished by the use of a liquid suspension of crystalline or amorphous material with poor water solubility. The rate of absorption of the drug then depends upon its rate of dissolution which, in turn, may depend upon crystal size and crystalline form. Alternatively, delayed absorption of a parenterally administered drug form is accomplished by dissolving or suspending the drug in an oil vehicle. Injectable depot forms are made by forming microencapsulated matrices of the drug in biodegradable polymers such as polylactide-polyglycolide. Depending upon the ratio of drug to polymer and the nature of the particular polymer employed, the rate of drug release can be controlled. Examples of other biodegradable polymers include poly(orthoesters) and poly(anhydrides). Depot injectable formulations are prepared by entrapping the drug in liposomes or microemulsions which are compatible with body tissues.

[00640] Compositions for rectal or vaginal administration are typically suppositories which can be prepared by mixing compositions with suitable non-irritating excipients such as cocoa butter, polyethylene glycol or a suppository wax which are solid at ambient temperature but liquid at body temperature and therefore melt in the rectum or vaginal cavity and release the active ingredient.

[00641] Solid dosage forms for oral administration include capsules, tablets, pills, films, powders, and granules. In such solid dosage forms, an active ingredient is mixed with at least one inert, pharmaceutically acceptable excipient such as sodium citrate or dicalcium phosphate and/or fillers or extenders (e.g., starches, lactose, sucrose, glucose, mannitol, and silicic acid), binders (e.g., carboxymethylcellulose, alginates, gelatin, polyvinylpyrrolidone, sucrose, and acacia), humectants (e.g., glycerol), disintegrating agents (e.g., agar, calcium carbonate, potato or tapioca starch, alginic acid, certain silicates, and sodium carbonate), solution retarding agents (e.g., paraffin), absorption accelerators (e.g., quaternary ammonium compounds), wetting agents (e.g., cetyl alcohol and glycerol monostearate), absorbents (e.g., kaolin and bentonite clay, silicates), and lubricants (e.g., talc, calcium stearate, magnesium stearate, solid polyethylene glycols, sodium lauryl sulfate), and mixtures thereof. In the case of capsules, tablets and pills, the dosage form may comprise buffering agents.

[00642] Solid compositions of a similar type may be employed as fillers in soft and hard-filled gelatin capsules using such excipients as lactose or milk sugar as well as high molecular weight polyethylene glycols and the like. Solid dosage forms of tablets, dragees, capsules, pills, and granules can be prepared with coatings and shells such as enteric coatings and other coatings well known in the pharmaceutical formulating art. They may optionally comprise opacifying agents and can be of a composition that they release the active ingredient(s) only, or preferentially, in a certain part of the intestinal tract, optionally, in a delayed manner. Examples of embedding compositions which can be used include polymeric substances and waxes. Solid compositions of a similar type may be employed as fillers in soft and hard-filled gelatin capsules using such excipients as lactose or milk sugar as well as high molecular weight polyethylene glycols and the like.

[00643] Dosage forms for topical and/or transdermal administration of a composition may include ointments, pastes, creams, lotions, gels, powders, solutions, sprays, inhalants, and/or patches. Generally, an active ingredient is admixed under sterile conditions with a pharmaceutically acceptable excipient and/or any needed preservatives and/or buffers as may be required. Additionally, the present disclosure contemplates the use of transdermal patches, which often have the added advantage of providing controlled delivery of a compound to the body. Such dosage forms may be prepared, for example, by dissolving and/or dispensing the compound in the proper medium. Alternatively or additionally, rate may be controlled by either

providing a rate controlling membrane and/or by dispersing the compound in a polymer matrix and/or gel.

[00644] Suitable devices for use in delivering intradermal pharmaceutical compositions described herein include short needle devices such as those described in U.S. Patents 4,886,499; 5,190,521; 5,328,483; 5,527,288; 4,270,537; 5,015,235; 5,141,496; and 5,417,662. Intradermal compositions may be administered by devices which limit the effective penetration length of a needle into the skin, such as those described in PCT publication WO 99/34850 and functional equivalents thereof. Jet injection devices which deliver liquid compositions to the dermis via a liquid jet injector and/or via a needle which pierces the stratum corneum and produces a jet which reaches the dermis are suitable. Jet injection devices are described, for example, in U.S. Patents 5,480,381; 5,599,302; 5,334,144; 5,993,412; 5,649,912; 5,569,189; 5,704,911; 5,383,851; 5,893,397; 5,466,220; 5,339,163; 5,312,335; 5,503,627; 5,064,413; 5,520,639; 4,596,556; 4,790,824; 4,941,880; 4,940,460; and PCT publications WO 97/37705 and WO 97/13537. Ballistic powder/particle delivery devices which use compressed gas to accelerate vaccine in powder form through the outer layers of the skin to the dermis are suitable. Alternatively or additionally, conventional syringes may be used in the classical mantoux method of intradermal administration.

[00645] Formulations suitable for topical administration include, but are not limited to, liquid and/or semi liquid preparations such as liniments, lotions, oil in water and/or water in oil emulsions such as creams, ointments and/or pastes, and/or solutions and/or suspensions. Topically-administrable formulations may, for example, comprise from about 1% to about 10% (wt/wt) active ingredient, although the concentration of active ingredient may be as high as the solubility limit of the active ingredient in the solvent. Formulations for topical administration may further comprise one or more of the additional ingredients described herein.

[00646] A pharmaceutical composition may be prepared, packaged, and/or sold in a formulation suitable for pulmonary administration via the buccal cavity. Such a formulation may comprise dry particles which comprise the active ingredient. Such compositions are conveniently in the form of dry powders for administration using a device comprising a dry powder reservoir to which a stream of propellant may be directed to disperse the powder and/or using a self-propelling solvent/powder dispensing container such as a device comprising the active ingredient dissolved and/or suspended in a low-boiling propellant in a sealed container.

Dry powder compositions may include a solid fine powder diluent such as sugar and are conveniently provided in a unit dose form.

[00647] Low boiling propellants generally include liquid propellants having a boiling point of below 65 °F at atmospheric pressure. Generally the propellant may constitute 50% to 99.9% (wt/wt) of the composition, and active ingredient may constitute 0.1% to 20% (wt/wt) of the composition. A propellant may further comprise additional ingredients such as a liquid non-ionic and/or solid anionic surfactant and/or a solid diluent (which may have a particle size of the same order as particles comprising the active ingredient).

[00648] Pharmaceutical compositions formulated for pulmonary delivery may provide an active ingredient in the form of droplets of a solution and/or suspension. Such formulations may be prepared, packaged, and/or sold as aqueous and/or dilute alcoholic solutions and/or suspensions, optionally sterile, comprising active ingredient, and may conveniently be administered using any nebulization and/or atomization device. Such formulations may further comprise one or more additional ingredients including, but not limited to, a flavoring agent such as saccharin sodium, a volatile oil, a buffering agent, a surface active agent, and/or a preservative such as methylhydroxybenzoate. Droplets provided by this route of administration may have an average diameter in the range from about 1 nm to about 200 nm.

[00649] Formulations described herein as being useful for pulmonary delivery are useful for intranasal delivery of a pharmaceutical composition. Another formulation suitable for intranasal administration is a coarse powder comprising the active ingredient and having an average particle from about 0.2 μm to 500 μm . Such a formulation is administered in the manner in which snuff is taken, i.e. by rapid inhalation through the nasal passage from a container of the powder held close to the nose.

[00650] Formulations suitable for nasal administration may, for example, comprise from about as little as 0.1% (wt/wt) and as much as 100% (wt/wt) of active ingredient, and may comprise one or more of the additional ingredients described herein. A pharmaceutical composition may be prepared, packaged, and/or sold in a formulation suitable for buccal administration. Such formulations may, for example, be in the form of tablets and/or lozenges made using conventional methods, and may, for example, 0.1% to 20% (wt/wt) active ingredient, the balance comprising an orally dissolvable and/or degradable composition and, optionally, one or more of the additional ingredients described herein. Alternately, formulations suitable for

buccal administration may comprise a powder and/or an aerosolized and/or atomized solution and/or suspension comprising active ingredient. Such powdered, aerosolized, and/or aerosolized formulations, when dispersed, may have an average particle and/or droplet size in the range from about 0.1 nm to about 200 nm, and may further comprise one or more of any additional ingredients described herein.

[00651] A pharmaceutical composition may be prepared, packaged, and/or sold in a formulation suitable for ophthalmic administration. Such formulations may, for example, be in the form of eye drops including, for example, a 0.1/1.0% (wt/wt) solution and/or suspension of the active ingredient in an aqueous or oily liquid excipient. Such drops may further comprise buffering agents, salts, and/or one or more other of any additional ingredients described herein. Other ophthalmically-administrable formulations which are useful include those which comprise the active ingredient in microcrystalline form and/or in a liposomal preparation. Ear drops and/or eye drops are contemplated as being within the scope of this present disclosure.

Methods of producing polypeptides in cells

[00652] The present disclosure provides methods of producing a polypeptide of interest in a mammalian cell. Methods of producing polypeptides involve contacting a cell with a formulation of the disclosure comprising a LNP including an mRNA encoding the polypeptide of interest. Upon contacting the cell with the lipid nanoparticle, the mRNA may be taken up and translated in the cell to produce the polypeptide of interest.

[00653] In general, the step of contacting a mammalian cell with a LNP including an mRNA encoding a polypeptide of interest may be performed *in vivo*, *ex vivo*, in culture, or *in vitro*. The amount of lipid nanoparticle contacted with a cell, and/or the amount of mRNA therein, may depend on the type of cell or tissue being contacted, the means of administration, the physiochemical characteristics of the lipid nanoparticle and the mRNA (*e.g.*, size, charge, and chemical composition) therein, and other factors. In general, an effective amount of the lipid nanoparticle will allow for efficient polypeptide production in the cell. Metrics for efficiency may include polypeptide translation (indicated by polypeptide expression), level of mRNA degradation, and immune response indicators.

[00654] The step of contacting a LNP including an mRNA with a cell may involve or cause transfection. A phospholipid including in the lipid component of a LNP may facilitate

transfection and/or increase transfection efficiency, for example, by interacting and/or fusing with a cellular or intracellular membrane. Transfection may allow for the translation of the mRNA within the cell.

[00655] In some embodiments, the lipid nanoparticles described herein may be used therapeutically. For example, an mRNA included in a LNP may encode a therapeutic polypeptide (*e.g.*, in a translatable region) and produce the therapeutic polypeptide upon contacting and/or entry (*e.g.*, transfection) into a cell. In some embodiments, an mRNA included in a LNP may encode a polypeptide that may improve or increase the immunity of a subject. In some embodiments, an mRNA may encode a granulocyte-colony stimulating factor or trastuzumab.

[00656] In some embodiments, an mRNA included in a LNP may encode a recombinant polypeptide that may replace one or more polypeptides that may be substantially absent in a cell contacted with the lipid nanoparticle. The one or more substantially absent polypeptides may be lacking due to a genetic mutation of the encoding gene or a regulatory pathway thereof. Alternatively, a recombinant polypeptide produced by translation of the mRNA may antagonize the activity of an endogenous protein present in, on the surface of, or secreted from the cell. An antagonistic recombinant polypeptide may be desirable to combat deleterious effects caused by activities of the endogenous protein, such as altered activities or localization caused by mutation. In another alternative, a recombinant polypeptide produced by translation of the mRNA may indirectly or directly antagonize the activity of a biological moiety present in, on the surface of, or secreted from the cell. Antagonized biological moieties may include, but are not limited to, lipids (*e.g.*, cholesterol), lipoproteins (*e.g.*, low density lipoprotein), nucleic acids, carbohydrates, and small molecule toxins. Recombinant polypeptides produced by translation of the mRNA may be engineered for localization within the cell, such as within a specific compartment such as the nucleus, or may be engineered for secretion from the cell or for translocation to the plasma membrane of the cell.

[00657] In some embodiments, contacting a cell with a LNP including an mRNA may reduce the innate immune response of a cell to an exogenous nucleic acid. A cell may be contacted with a first lipid nanoparticle including a first amount of a first exogenous mRNA including a translatable region and the level of the innate immune response of the cell to the first exogenous mRNA may be determined. Subsequently, the cell may be contacted with a second composition

including a second amount of the first exogenous mRNA, the second amount being a lesser amount of the first exogenous mRNA compared to the first amount. Alternatively, the second composition may include a first amount of a second exogenous mRNA that is different from the first exogenous mRNA. The steps of contacting the cell with the first and second compositions may be repeated one or more times. Additionally, efficiency of polypeptide production (e.g., translation) in the cell may be optionally determined, and the cell may be re-contacted with the first and/or second composition repeatedly until a target protein production efficiency is achieved.

Methods of delivering therapeutic agents to cells and organs

[00658] The present disclosure provides methods of delivering a therapeutic and/or prophylactic, such as a nucleic acid, to a mammalian cell or organ. Delivery of a therapeutic and/or prophylactic to a cell involves administering a formulation of the disclosure that comprises a LNP including the therapeutic and/or prophylactic, such as a nucleic acid, to a subject, where administration of the composition involves contacting the cell with the composition. In some embodiments, a protein, cytotoxic agent, radioactive ion, chemotherapeutic agent, or nucleic acid (such as an RNA, *e.g.*, mRNA) may be delivered to a cell or organ. In the instance that a therapeutic and/or prophylactic is an mRNA, upon contacting a cell with the lipid nanoparticle, a translatable mRNA may be translated in the cell to produce a polypeptide of interest. However, mRNAs that are substantially not translatable may also be delivered to cells. Substantially non-translatable mRNAs may be useful as vaccines and/or may sequester translational components of a cell to reduce expression of other species in the cell.

[00659] In some embodiments, a LNP may target a particular type or class of cells (*e.g.*, cells of a particular organ or system thereof). In some embodiments, a LNP including a therapeutic and/or prophylactic of interest may be specifically delivered to a mammalian liver, kidney, spleen, femur, or lung. Specific delivery to a particular class of cells, an organ, or a system or group thereof implies that a higher proportion of lipid nanoparticles including a therapeutic and/or prophylactic are delivered to the destination (*e.g.*, tissue) of interest relative to other destinations, *e.g.*, upon administration of a LNP to a mammal. In some embodiments, specific delivery may result in a greater than 2 fold, 5 fold, 10 fold, 15 fold, or 20 fold increase in the amount of therapeutic and/or prophylactic per 1 g of tissue of the targeted destination (*e.g.*, tissue

of interest, such as a liver) as compared to another destination (*e.g.*, the spleen). In some embodiments, the tissue of interest is selected from the group consisting of a liver, kidney, a lung, a spleen, a femur, vascular endothelium in vessels (*e.g.*, intra-coronary or intra-femoral) or kidney, and tumor tissue (*e.g.*, via intratumoral injection).

[00660] As another example of targeted or specific delivery, an mRNA that encodes a protein-binding partner (*e.g.*, an antibody or functional fragment thereof, a scaffold protein, or a peptide) or a receptor on a cell surface may be included in a LNP. An mRNA may additionally or instead be used to direct the synthesis and extracellular localization of lipids, carbohydrates, or other biological moieties. Alternatively, other therapeutics and/or prophylactics or elements (*e.g.*, lipids or ligands) of a LNP may be selected based on their affinity for particular receptors (*e.g.*, low density lipoprotein receptors) such that a LNP may more readily interact with a target cell population including the receptors. In some embodiments, ligands may include, but are not limited to, members of a specific binding pair, antibodies, monoclonal antibodies, Fv fragments, single chain Fv (scFv) fragments, Fab' fragments, F(ab')₂ fragments, single domain antibodies, camelized antibodies and fragments thereof, humanized antibodies and fragments thereof, and multivalent versions thereof; multivalent binding reagents including mono- or bi-specific antibodies such as disulfide stabilized Fv fragments, scFv tandems, diabodies, tribodies, or tetrabodies; and aptamers, receptors, and fusion proteins.

[00661] In some embodiments, a ligand may be a surface-bound antibody, which can permit tuning of cell targeting specificity. This is especially useful since highly specific antibodies can be raised against an epitope of interest for the desired targeting site. In some embodiments, multiple antibodies are expressed on the surface of a cell, and each antibody can have a different specificity for a desired target. Such approaches can increase the avidity and specificity of targeting interactions.

[00662] A ligand can be selected, *e.g.*, by a person skilled in the biological arts, based on the desired localization or function of the cell. In some embodiments an estrogen receptor ligand, such as tamoxifen, can target cells to estrogen-dependent breast cancer cells that have an increased number of estrogen receptors on the cell surface. Other non-limiting examples of ligand/receptor interactions include CCR1 (*e.g.*, for treatment of inflamed joint tissues or brain in rheumatoid arthritis, and/or multiple sclerosis), CCR7, CCR8 (*e.g.*, targeting to lymph node tissue), CCR6, CCR9, CCR10 (*e.g.*, to target to intestinal tissue), CCR4, CCR10 (*e.g.*, for

targeting to skin), CXCR4 (*e.g.*, for general enhanced transmigration), HCELL (*e.g.*, for treatment of inflammation and inflammatory disorders, bone marrow), Alpha4beta7 (*e.g.*, for intestinal mucosa targeting), and VLA-4NCAM-1 (*e.g.*, targeting to endothelium). In general, any receptor involved in targeting (*e.g.*, cancer metastasis) can be harnessed for use in the methods and compositions described herein.

[00663] Targeted cells may include, but are not limited to, hepatocytes, epithelial cells, hematopoietic cells, epithelial cells, endothelial cells, lung cells, bone cells, stem cells, mesenchymal cells, neural cells, cardiac cells, adipocytes, vascular smooth muscle cells, cardiomyocytes, skeletal muscle cells, beta cells, pituitary cells, synovial lining cells, ovarian cells, testicular cells, fibroblasts, B cells, T cells, reticulocytes, leukocytes, granulocytes, and tumor cells.

[00664] In some embodiments, a LNP may target hepatocytes. Apolipoproteins such as apolipoprotein E (apoE) have been shown to associate with neutral or near neutral lipid-containing lipid nanoparticles in the body, and are known to associate with receptors such as low-density lipoprotein receptors (LDLRs) found on the surface of hepatocytes. Thus, a LNP including a lipid component with a neutral or near neutral charge that is administered to a subject may acquire apoE in a subject's body and may subsequently deliver a therapeutic and/or prophylactic (*e.g.*, an RNA) to hepatocytes including LDLRs in a targeted manner.

Methods of treating diseases and disorders

[00665] Lipid nanoparticles may be useful for treating a disease, disorder, or condition. In particular, such compositions may be useful in treating a disease, disorder, or condition characterized by missing or aberrant protein or polypeptide activity. In some embodiments, a formulation of the disclosure that comprises a LNP including an mRNA encoding a missing or aberrant polypeptide may be administered or delivered to a cell. Subsequent translation of the mRNA may produce the polypeptide, thereby reducing or eliminating an issue caused by the absence of or aberrant activity caused by the polypeptide. Because translation may occur rapidly, the methods and compositions may be useful in the treatment of acute diseases, disorders, or conditions such as sepsis, stroke, and myocardial infarction. A therapeutic and/or prophylactic included in a LNP may also be capable of altering the rate of transcription of a given species, thereby affecting gene expression.

[00666] Diseases, disorders, and/or conditions characterized by dysfunctional or aberrant protein or polypeptide activity for which a composition may be administered include, but are not limited to, rare diseases, infectious diseases (as both vaccines and therapeutics), cancer and proliferative diseases, genetic diseases (*e.g.*, cystic fibrosis), autoimmune diseases, diabetes, neurodegenerative diseases, cardio- and reno-vascular diseases, and metabolic diseases.

Multiple diseases, disorders, and/or conditions may be characterized by missing (or substantially diminished such that proper protein function does not occur) protein activity. Such proteins may not be present, or they may be essentially non-functional. A specific example of a dysfunctional protein is the missense mutation variants of the cystic fibrosis transmembrane conductance regulator (CFTR) gene, which produce a dysfunctional protein variant of CFTR protein, which causes cystic fibrosis. The present disclosure provides a method for treating such diseases, disorders, and/or conditions in a subject by administering a LNP including an RNA and a lipid component including a lipid according to Formula (I), a phospholipid (optionally unsaturated), a PEG lipid, and a structural lipid, wherein the RNA may be an mRNA encoding a polypeptide that antagonizes or otherwise overcomes an aberrant protein activity present in the cell of the subject.

[00667] The disclosure provides methods involving administering lipid nanoparticles including one or more therapeutic and/or prophylactic agents, such as a nucleic acid, and pharmaceutical compositions including the same. The terms therapeutic and prophylactic can be used interchangeably herein with respect to features and embodiments of the present disclosure. Therapeutic compositions, or imaging, diagnostic, or prophylactic compositions thereof, may be administered to a subject using any reasonable amount and any route of administration effective for preventing, treating, diagnosing, or imaging a disease, disorder, and/or condition and/or any other purpose. The specific amount administered to a given subject may vary depending on the species, age, and general condition of the subject; the purpose of the administration; the particular composition; the mode of administration; and the like. Compositions in accordance with the present disclosure may be formulated in dosage unit form for ease of administration and uniformity of dosage. It will be understood, however, that the total daily usage of a composition of the present disclosure will be decided by an attending physician within the scope of sound medical judgment. The specific therapeutically effective, prophylactically effective, or otherwise appropriate dose level (*e.g.*, for imaging) for any particular patient will depend upon a

variety of factors including the severity and identify of a disorder being treated, if any; the one or more therapeutics and/or prophylactics employed; the specific composition employed; the age, body weight, general health, sex, and diet of the patient; the time of administration, route of administration, and rate of excretion of the specific pharmaceutical composition employed; the duration of the treatment; drugs used in combination or coincidental with the specific pharmaceutical composition employed; and like factors well known in the medical arts.

[00668] A LNP including one or more therapeutics and/or prophylactics, such as a nucleic acid, may be administered by any route. In some embodiments, compositions, including prophylactic, diagnostic, or imaging compositions including one or more lipid nanoparticles described herein, are administered by one or more of a variety of routes, including oral, intravenous, intramuscular, intra-arterial, intramedullary, intrathecal, subcutaneous, intraventricular, trans- or intra-dermal, interdermal, rectal, intravaginal, intraperitoneal, topical (e.g., by powders, ointments, creams, gels, lotions, and/or drops), mucosal, nasal, buccal, enteral, intravitreal, intratumoral, sublingual, intranasal; by intratracheal instillation, bronchial instillation, and/or inhalation; as an oral spray and/or powder, nasal spray, and/or aerosol, and/or through a portal vein catheter. In some embodiments, a composition may be administered intravenously, intramuscularly, intradermally, intra-arterially, intratumorally, subcutaneously, or by inhalation. However, the present disclosure encompasses the delivery or administration of compositions described herein by any appropriate route taking into consideration likely advances in the sciences of drug delivery. In general, the most appropriate route of administration will depend upon a variety of factors including the nature of the lipid nanoparticle including one or more therapeutics and/or prophylactics (e.g., its stability in various bodily environments such as the bloodstream and gastrointestinal tract), the condition of the patient (e.g., whether the patient is able to tolerate particular routes of administration), etc.

[00669] In certain embodiments, compositions in accordance with the present disclosure may be administered at dosage levels sufficient to deliver from about 0.0001 mg/kg to about 10 mg/kg, from about 0.001 mg/kg to about 10 mg/kg, from about 0.005 mg/kg to about 10 mg/kg, from about 0.01 mg/kg to about 10 mg/kg, from about 0.05 mg/kg to about 10 mg/kg, from about 0.1 mg/kg to about 10 mg/kg, from about 1 mg/kg to about 10 mg/kg, from about 2 mg/kg to about 10 mg/kg, from about 5 mg/kg to about 10 mg/kg, from about 0.0001 mg/kg to about 5 mg/kg, from about 0.001 mg/kg to about 5 mg/kg, from about 0.005 mg/kg to about 5 mg/kg,

from about 0.01 mg/kg to about 5 mg/kg, from about 0.05 mg/kg to about 5 mg/kg, from about 0.1 mg/kg to about 5 mg/kg, from about 1 mg/kg to about 5 mg/kg, from about 2 mg/kg to about 5 mg/kg, from about 0.0001 mg/kg to about 2.5 mg/kg, from about 0.001 mg/kg to about 2.5 mg/kg, from about 0.005 mg/kg to about 2.5 mg/kg, from about 0.01 mg/kg to about 2.5 mg/kg, from about 0.05 mg/kg to about 2.5 mg/kg, from about 0.1 mg/kg to about 2.5 mg/kg, from about 1 mg/kg to about 2.5 mg/kg, from about 2 mg/kg to about 2.5 mg/kg, from about 0.0001 mg/kg to about 1 mg/kg, from about 0.001 mg/kg to about 1 mg/kg, from about 0.005 mg/kg to about 1 mg/kg, from about 0.01 mg/kg to about 1 mg/kg, from about 0.05 mg/kg to about 1 mg/kg, from about 0.1 mg/kg to about 1 mg/kg, from about 0.0001 mg/kg to about 0.25 mg/kg, from about 0.001 mg/kg to about 0.25 mg/kg, from about 0.005 mg/kg to about 0.25 mg/kg, from about 0.01 mg/kg to about 0.25 mg/kg, from about 0.05 mg/kg to about 0.25 mg/kg, or from about 0.1 mg/kg to about 0.25 mg/kg of a therapeutic and/or prophylactic (*e.g.*, an mRNA) in a given dose, where a dose of 1 mg/kg (mpk) provides 1 mg of a therapeutic and/or prophylactic per 1 kg of subject body weight. In some embodiments, a dose of about 0.001 mg/kg to about 10 mg/kg of a therapeutic and/or prophylactic (*e.g.*, mRNA) of a LNP may be administered. In some embodiments, a dose of about 0.005 mg/kg to about 2.5 mg/kg of a therapeutic and/or prophylactic may be administered. In certain embodiments, a dose of about 0.1 mg/kg to about 1 mg/kg may be administered. In some embodiments, a dose of about 0.05 mg/kg to about 0.25 mg/kg may be administered. A dose may be administered one or more times per day, in the same or a different amount, to obtain a desired level of mRNA expression and/or therapeutic, diagnostic, prophylactic, or imaging effect. The desired dosage may be delivered, for example, three times a day, two times a day, once a day, every other day, every third day, every week, every two weeks, every three weeks, or every four weeks. In certain embodiments, the desired dosage may be delivered using multiple administrations (*e.g.*, two, three, four, five, six, seven, eight, nine, ten, eleven, twelve, thirteen, fourteen, or more administrations). In some embodiments, a single dose may be administered, for example, prior to or after a surgical procedure or in the instance of an acute disease, disorder, or condition.

[00670] Lipid nanoparticles including one or more therapeutics and/or prophylactics, such as a nucleic acid, may be used in combination with one or more other therapeutic, prophylactic, diagnostic, or imaging agents. By “in combination with,” it is not intended to imply that the agents must be administered at the same time and/or formulated for delivery together, although

these methods of delivery are within the scope of the present disclosure. In some embodiments, one or more lipid nanoparticles including one or more different therapeutics and/or prophylactics may be administered in combination. Compositions can be administered concurrently with, prior to, or subsequent to, one or more other desired therapeutics or medical procedures. In general, each agent will be administered at a dose and/or on a time schedule determined for that agent. In some embodiments, the present disclosure encompasses the delivery of compositions, or imaging, diagnostic, or prophylactic compositions thereof in combination with agents that improve their bioavailability, reduce and/or modify their metabolism, inhibit their excretion, and/or modify their distribution within the body.

[00671] It will further be appreciated that therapeutically, prophylactically, diagnostically, or imaging active agents utilized in combination may be administered together in a single composition or administered separately in different compositions. In general, it is expected that agents utilized in combination will be utilized at levels that do not exceed the levels at which they are utilized individually. In some embodiments, the levels utilized in combination may be lower than those utilized individually.

[00672] The particular combination of therapies (therapeutics or procedures) to employ in a combination regimen will take into account compatibility of the desired therapeutics and/or procedures and the desired therapeutic effect to be achieved. It will also be appreciated that the therapies employed may achieve a desired effect for the same disorder (for example, a composition useful for treating cancer may be administered concurrently with a chemotherapeutic agent), or they may achieve different effects (*e.g.*, control of any adverse effects, such as infusion related reactions).

[00673] A LNP may be used in combination with an agent to increase the effectiveness and/or therapeutic window of the composition. Such an agent may be, for example, an anti-inflammatory compound, a steroid (*e.g.*, a corticosteroid), a statin, an estradiol, a BTK inhibitor, an S1P1 agonist, a glucocorticoid receptor modulator (GRM), or an anti-histamine. In some embodiments, a LNP may be used in combination with dexamethasone, methotrexate, acetaminophen, an H1 receptor blocker, or an H2 receptor blocker. In some embodiments, a method of treating a subject in need thereof or of delivering a therapeutic and/or prophylactic to a subject (*e.g.*, a mammal) may involve pre-treating the subject with one or more agents prior to administering a LNP. In some embodiments, a subject may be pre-treated with a useful amount

(*e.g.*, 10 mg, 20 mg, 30 mg, 40 mg, 50 mg, 60 mg, 70 mg, 80 mg, 90 mg, 100 mg, or any other useful amount) of dexamethasone, methotrexate, acetaminophen, an H1 receptor blocker, or an H2 receptor blocker. Pre-treatment may occur 24 or fewer hours (*e.g.*, 24 hours, 20 hours, 16 hours, 12 hours, 8 hours, 4 hours, 2 hours, 1 hour, 50 minutes, 40 minutes, 30 minutes, 20 minutes, or 10 minutes) before administration of the lipid nanoparticle and may occur one, two, or more times in, for example, increasing dosage amounts.

[00674] Those skilled in the art will recognize, or be able to ascertain using no more than routine experimentation, many equivalents to the specific embodiments in accordance with the disclosure described herein. The scope of the present disclosure is not intended to be limited to the above Description, but rather is as set forth in the appended claims.

[00675] In the claims, articles such as “a,” “an,” and “the” may mean one or more than one unless indicated to the contrary or otherwise evident from the context. Claims or descriptions that include “or” between one or more members of a group are considered satisfied if one, more than one, or all of the group members are present in, employed in, or otherwise relevant to a given product or process unless indicated to the contrary or otherwise evident from the context. The disclosure includes embodiments in which exactly one member of the group is present in, employed in, or otherwise relevant to a given product or process. The disclosure includes embodiments in which more than one, or all, of the group members are present in, employed in, or otherwise relevant to a given product or process.

[00676] It is also noted that the term “comprising” is intended to be open and permits but does not require the inclusion of additional elements or steps. When the term “comprising” is used herein, the terms “consisting essentially of” and “consisting of” are thus also encompassed and disclosed. Throughout the description, where compositions are described as having, including, or comprising specific components, it is contemplated that compositions also consist essentially of, or consist of, the recited components. Similarly, where methods or processes are described as having, including, or comprising specific process steps, the processes also consist essentially of, or consist of, the recited processing steps. Further, it should be understood that the order of steps or order for performing certain actions is immaterial so long as the invention remains operable. Moreover, two or more steps or actions can be conducted simultaneously.

[00677] Where ranges are given, endpoints are included. Furthermore, it is to be understood that unless otherwise indicated or otherwise evident from the context and understanding of one

of ordinary skill in the art, values that are expressed as ranges can assume any specific value or sub-range within the stated ranges in different embodiments of the disclosure, to the tenth of the unit of the lower limit of the range, unless the context clearly dictates otherwise.

[00678] In addition, it is to be understood that any particular embodiment of the present disclosure that falls within the prior art may be explicitly excluded from any one or more of the claims. Since such embodiments are deemed to be known to one of ordinary skill in the art, they may be excluded even if the exclusion is not set forth explicitly herein.

[00679] All cited sources, for example, references, publications, patent applications, databases, database entries, and art cited herein, are incorporated into this application by reference, even if not expressly stated in the citation. In case of conflicting statements of a cited source and the instant application, the statement in the instant application shall control.

[00680] The disclosure having been described, the following examples are offered by way of illustration and not limitation.

Examples

Example 1: Preparation of organic soluble mRNA

[00681] It was found that mRNA can be solubilized in organic solvents to enable formulation with diverse nanoparticle delivery platforms and approaches. Organic soluble mRNA may simplify the mixing requirements during nanoprecipitation (Figure 1). Simplification of mixing has shown promise towards enabling high-throughput formulation approaches and strategies contemplated for bedside applications. Intermediate salts of mRNA enable incorporation of mRNA into nanoparticles via the organic phase. Standard LNP formulation techniques rely on mRNA extraction from aqueous streams during particle formulation in processes that limit control prior to and during particle formation.

[00682] Directly forming cationic lipid-mRNA salts from water-soluble mRNA is challenging. Mixing aqueous mRNA and cationic lipids generally leads to interface precipitation where precipitates are no longer water soluble but generally not soluble in organic solvents either. Rapid precipitation may result in inefficient cation exchange where products are mRNA salts containing both hydrophilic (e.g. sodium) and hydrophobic (e.g. cationic lipid) counterions. Thus, proceeding through intermediate mRNA salt forms that straddle aqueous and organic solubility spectrum were examined. Intermediate salt forms (e.g. TBA-mRNA, the tributylamine

salt form) may be pulled from reversed-phase ion pairing chromatography techniques for oligonucleotide purification. The approach is envisioned to impart enough hydrophobicity to mRNA to achieve organic solubility while avoiding mRNA precipitation.

[00683] Pretreatment of the mRNA with a heat cycle can be included in the organic soluble mRNA conversion process. A solution of approximately 1 mg/mL mRNA in the initial aqueous soluble form is heated to 65 °C, held at the target temperature for 5 minutes, then rapidly cooled in a water/ice bath.

[00684] Simple buffer exchange results in intermediate salts and can be accomplished by a variety of ways depending on the scale of mRNA needed. For example, mRNA (1-10 mg/mL) may be diluted in 10 mM tributylammonium acetate (TBAA, ~pH 6.5) and placed in an appropriate MWCO dialysis tube or cassette. The mRNA may be dialyzed extensively against the buffer to replace the hydrophilic cations with TBA molecules. For example, dialysis against 10 diavolumes of 10 mM TBAA ~pH 6.5 with replacement of buffer ~3 times over 24 hours may be performed, and the dialysis bag/cassette contents may be lyophilized to a white powder. For larger scales a tangential flow filtration (TFF) may be performed with fundamental processes, buffers, and concepts remaining the same.

[00685] The intermediate cation remaining in the particle is undesirable. Chemical properties of the intermediate cation and cationic lipid may dictate removal efficiency during formulation. Alternative intermediate cations may be screened to define the hydrophobicity needed for mRNA solubility in organic solvents. This may be focused on finding the least hydrophobic counter ion capable of generating organic solvent soluble mRNA salts with the lower hydrophobicity of intermediate cations promoting extraction and ion exchange with cationic lipids during nanoparticle formation. A combination of large delta in log D values between cations and large surface to volume ratio for collapsing organic droplets may result in efficient exchange. Exemplary suitable cations identified as possible intermediate salts include, but are not limited to, tributylamine (TBA, cLog P = 4.7, cLog D5.0 = 1.6), tripropylamine (TPA, cLog P = 3.2, cLog D5.0 = 0.1), triethylamine (TEA, cLog P = 1.7, cLog D5.0 = -1.5), diisopropanolamine (cLog P = -1.1, cLog D5.0 = -4.1), and the like.

Preparation of (TBAA) stock solution

[00686] A stock concentration of tributylammonium acetate (TBAA) was initially prepared from tributylamine and acetic acid. In brief, tributyl amine was prepared at 100 mM in water

and allowed to stir at room temperature for 1 hour. Glacial acetic acid (initial 1:1 stoichiometry) was added and the pH monitored. Additional glacial acetic acid was added until the pH was adjusted between 6.3-6.6. The TBAA stock is mixed thoroughly and allowed to stir overnight in a fume hood. This solution is then cooled at 4 °C.

Dialysis method for the preparation of TBA:mRNA salt

[00687] A stock 100 mM TBAA solution was first diluted down to 10 mM with water and cooled to ~4 °C. This procedure is specific for preparing a volume of 15 mL, but can be adjusted based on amount of mRNA salt required. A specific mass of mRNA was added to a 50 mL conical tube. Based on an average nucleoside monophosphate molecular weight of 344 g/mol, the number of moles of mRNA was calculated. The ratio of TBA:mRNA was initially kept between 1:1 and 3:1. An appropriate amount of TBAA stock was added to the mRNA and the volume adjusted to 15 mL. This solution was kept on ice until addition to a dialysis cassette (20 kDa MWCO). The mRNA:TBA solution was dialyzed against cold TBAA (10 mM, 2 L) for 2 hours. The dialysis medium was changed to fresh TBAA (10 mM, 2 L). After 2 additional hours the mRNA:TBA solution was removed from the dialysis cassette and flash frozen in a 50 mL conical tube with liquid nitrogen. This material was lyophilized, resulting in a flaky white powder.

Tangential flow filtration (TFF) method for the preparation of TBA:mRNA salt

[00688] The 100 mM TBAA solution was first diluted down to 10 mM with water and cooled to ~4 °C. This procedure was specific to converting 200 mg mRNA to TBA salt, but can be adjusted accordingly. To get an initial ratio of 1:1 TBA:mRNA, TBAA (10 mM, 104 mL) was added and the total volume brought to 200 mL with water. This solution was kept on ice and circulated through a cold TFF (300 kDa MWCO membrane) against 5 diavolumes of TBAA (10mM) for 5-10 minutes. The 5 diavolumes are then sent to waste and the retained mRNA:TBA solution is collected (~200 mL). This solution is divided into an appropriate number of 50 mL conical tubes and flash frozen with liquid nitrogen. This material is lyophilized, resulting in a flaky white powder.

Dissolution of mRNA-TBA in benzyl alcohol and ethanol

[00689] Initial stock solutions of mRNA-tributylamine (TBA) salt were prepared at 10 mg/mL (6.5 mg/mL free mRNA) in benzyl alcohol. After addition of benzyl alcohol to the respective mRNA-TBA salt, the solution was placed on a vortex shaker for 15-60 minutes at room

temperature. Once dissolved in benzyl alcohol, further dilution with ethanol can be performed. The mRNA content in the ethanol/benzyl alcohol stock solutions was determined using a RiboGreen assay.

Example 2: Preparation of organic feed mRNA (OFM) lipid nanoparticle (LNP) formulations

Characterization of nanoparticle compositions

[00690] A Zetasizer Nano ZS (Malvern Instruments Ltd, Malvern, Worcestershire, UK) can be used to determine the particle size, the polydispersity index (PDI) and the zeta potential of the nanoparticle compositions in 1×PBS in determining particle size and 15 mM PBS in determining zeta potential.

[00691] Ultraviolet-visible spectroscopy can be used to determine the concentration of a therapeutic and/or prophylactic agent (e.g., RNA) in nanoparticle compositions. 100 µL of the diluted formulation in 1×PBS is added to 900 µL of a 4:1 (v/v) mixture of methanol and chloroform. After mixing, the absorbance spectrum of the solution is recorded, for example, between 230 nm and 330 nm on a DU 800 spectrophotometer (Beckman Coulter, Beckman Coulter, Inc., Brea, CA). The concentration of therapeutic and/or prophylactic agent in the nanoparticle composition can be calculated based on the extinction coefficient of the therapeutic and/or prophylactic agent used in the composition and on the difference between the absorbance at a wavelength of, for example, 260 nm and the baseline value at a wavelength of, for example, 330 nm.

[00692] For nanoparticle composition including an RNA, a QUANT-IT™ RIBOGREEN® RNA assay (Invitrogen Corporation, Carlsbad, CA) can be used to evaluate the encapsulation of an RNA by the nanoparticle composition. The samples are diluted to a concentration of approximately 5 µg/mL in a TE buffer solution (10 mM Tris-HCl, 1 mM EDTA, pH 7.5). 50 µL of the diluted samples are transferred to a polystyrene 96 well plate and either 50 µL of TE buffer or 50 µL of a 2% Triton X-100 solution is added to the wells. The plate is incubated at a temperature of 37 °C for 15 minutes. The RIBOGREEN® reagent is diluted 1:100 in TE buffer, and 100 µL of this solution is added to each well. The fluorescence intensity can be measured using a fluorescence plate reader (Wallac Victor 1420 Multilabel Counter; Perkin Elmer, Waltham, MA) at an excitation wavelength of, for example, about 480 nm and an emission

wavelength of, for example, about 520 nm. The fluorescence values of the reagent blank are subtracted from that of each of the samples and the percentage of free RNA is determined by dividing the fluorescence intensity of the intact sample (without addition of Triton X-100) by the fluorescence value of the disrupted sample (caused by the addition of Triton X-100).

General procedure for organic feed mRNA

[00693] In order to investigate safe and efficacious nanoparticle compositions for use in the delivery of therapeutic and/or prophylactic agents to cells, a range of formulations are prepared and tested. Specifically, the particular elements and ratios thereof in the lipid component of nanoparticle compositions are optimized. Nanoparticles can be made with mixing processes such as microfluidics and T-junction mixing of two fluid streams, one of which is organic containing the therapeutic and/or prophylactic agent (i.e. mRNA) as well as the lipid components (i.e. ionizable/cationic lipid, structural lipid, phospholipid/helper lipids, PEG lipid) and the other aqueous buffered to facilitate formation of the lipid nanoparticle.

[00694] Organic soluble mRNA (prepared as described herein) can be co-solubilized with standard lipid mixtures in ethanol to produce functional lipid nanoparticles (LNPs). Organic feed solutions of lipid compositions and mRNA may be prepared by combining a lipid according to one of formulae described herein, a phospholipid (such as DOPE or DSPC, obtainable from Avanti Polar Lipids, Alabaster, AL), a PEG lipid (such as 1,2-dimyristoyl-sn-glycerol methoxypolyethylene glycol, also known as PEG-DMG, obtainable from Avanti Polar Lipids, Alabaster, AL, or a PEG lipid according to one of the formulae described herein), and a structural lipid (such as cholesterol, obtainable from Sigma-Aldrich, Taufkirchen, Germany) at concentrations of about 50 mM in ethanol and mRNA at a concentration of approximately 0.05-0.50 mg/mL. Solutions should be refrigerated for storage at, for example, -20° C. Lipids are combined to yield desired molar ratios and diluted with water and/or ethanol to a final lipid concentration of between about 5.5 mM and about 25 mM.

[00695] Nanoparticle compositions including a therapeutic and/or prophylactic agent (i.e. RNA, mRNA) and a lipid component are prepared by combining the organic feed solution with an aqueous solution (i.e. acetate buffer 5-10 mM, pH ~5.0) at volume ratios between about 1:1 and about 50:1. The organic solution may be rapidly injected using a NanoAssemblr microfluidic based system at flow rates between about 10 ml/min and about 18 ml/min into the

aqueous solution to produce a suspension with a water to ethanol ratio between about 1:1 and about 4:1.

[00696] Nanoparticle compositions can be processed by dialysis to remove ethanol and achieve buffer exchange. Formulations may be dialyzed twice against phosphate buffered saline (PBS), pH 7.4, at volumes 200 times that of the primary product using Slide-A-Lyzer cassettes (Thermo Fisher Scientific Inc., Rockford, IL) with a molecular weight cutoff of 10 kD. The first dialysis may be carried out at room temperature for 3 hours. The formulations may then be dialyzed overnight at 4° C. The resulting nanoparticle suspension may be filtered through 0.2 µm sterile filters (Sarstedt, Nümbrecht, Germany) into glass vials and sealed with crimp closures. Nanoparticle composition solutions of 0.01 mg/ml to 0.10 mg/ml are generally obtained.

[00697] The general method described above induces nano-precipitation and particle formation. Alternative processes including, but not limited to, T-junction and direct injection, as well as stirring by tumbling disc or high-throughput mixing may be used to achieve the same nano-precipitation. Organic soluble mRNA in ethanol feed has the potential to improve process efficiencies, reproducibility, and scalability of mRNA LNPs. Broadly, potential for organic (i.e. ethanol) feeding mRNA with standard lipid mixtures is high including simplified mixing, reduced fouling, and composition flexibility. In terms of simplified mixing there is no need to extract mRNA from the aqueous phase during particle formation. This may allow for greater size control through traditional surfactant and mixing energy techniques. The expected reduction in fouling is in prevention of mRNA precipitation at the water/ethanol interface during particle formation. In terms of composition flexibility, the removal of mRNA partitioning during the formulation process should allow for increased excipient flexibility, especially with regards to oil/water interface species, such as PEG lipids. These methods have further potential to reduce the reliance on post insertion of LNP surface modifying stabilizers and the flexibility of alternative organic solvents and solvent ratios,

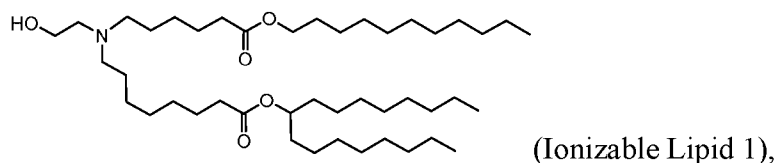

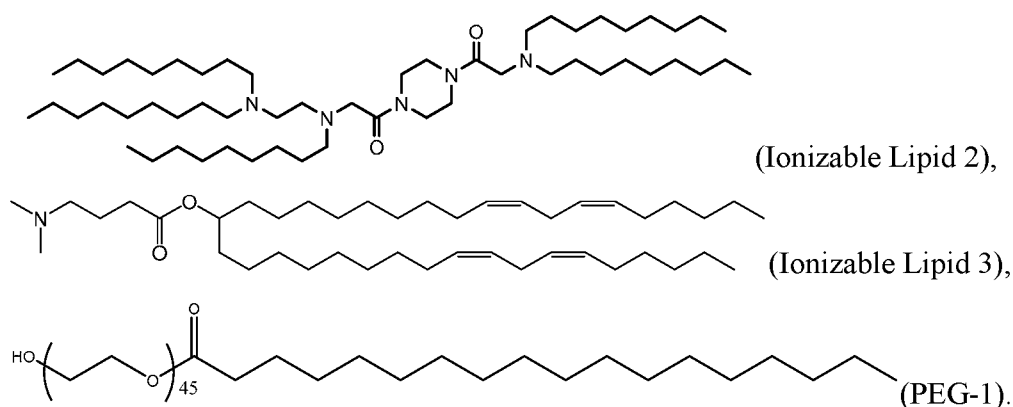

[00698] To assess activity of mRNA passed through the intermediate salt form hydrophobic luciferase mRNA organic feed was used to generate LNPs from standard lipid compositions by nanoprecipitation. The formulations can be made using simple mixing in a stirring vial or NanoAssemblr™ microfluidic mixing device. Ethanol feeding TBA-mRNA with standard LNP lipid mixtures formed functional particles demonstrating high encapsulation efficiencies and fairly uniform sizes over various combinations (Table 1). Cryo images for nanoprecipitated particles show well-defined, fairly uniform particle structures with a well-defined multilamellar architecture even when using relatively crude mixing approaches (Figure 2). Similar *in vitro* expression was observed when comparing NanoAssemblr mixing processes with traditional aqueous feed mRNA or organic ethanol feed TBA-mRNA (Figure 3 and Figure 4).

Table 1: Summary of organic feed nanoprecipitated LNPs using TBA-mRNA

Lipid mix	Size Diameter (nm)	PDI	%EE (RiboGreen)	[mRNA] _{total} (μg/mL)
Ionizable Lipid - 1/DSPC/Cholesterol/PEG- DMG	101	0.13	98%	63
Ionizable Lipid - 1/DSPC/Cholesterol/PEG-1	97	0.12	99%	61
Ionizable Lipid - 3/DSPC/Cholesterol/PEG- DMG	104	0.15	98%	59

Ionizable Lipid - 2/DSPC/Cholesterol/PEG- DMG	100	0.10	99%	52
-----------------------------------------------------	-----	------	-----	----

Organic mRNA feed NanoAssemblr™ mixing procedure

[00699] Lipid nanoparticles (LNPs) may be formed using a microfluidics mixing chamber (NanoAssemblr™) combining an aqueous solution of buffer (acetate buffer 6.25 mM, pH 5.0) with an ethanol solution containing organic fed mRNA (~ 0.1-0.5 mg/mL) cationic lipid (Ionizable Lipid 1), cholesterol as structural lipid, helper lipids (DSPC) as phospholipid, and PEG lipids (PEG2K-DMG) (48:40.5:10:1.5 mole ratio) at a 3:1 volume ratio. The resulting LNP containing solution may be dialyzed at 4 °C against 4000 mL of PBS buffer (pH 7.4) and exchanged 2 times over 18 hours. The collected nanoparticles were tested for accessible mRNA using Ribogreen quantification assay and particle sizing by dynamic light scattering (DLS). Prior to in vivo dosing, particles were concentrated using centrifugal filter devices (Millipore Amicon Ultra 100 kDA MWCO, 4 °C). After concentration, the sample was filtered (0.2 µm)..

T-mixing procedure of organic feed mRNA procedure

[00700] A lipid stock containing a cationic lipid (Ionizable Lipid 1), cholesterol as structural lipid, helper lipid DSPC as phospholipid and PEG lipid in a molar ratio of 50:38.5:10:1.5 was mixed with mRNA dissolved in benzyl alcohol/ethanol. The organic feed containing lipids mRNA were loaded into a syringe and mixed in a volume ratio of 3:1 with sodium acetate using a PEEK T junction. An initial T-mix batch at a 5 mg scale was successfully run employing a Tech Dev apparatus. The T-mixed product (TMP) was inline diluted, adjusted to the desired final pH, and the mRNA-loaded lipid nanoparticles were concentrated, and residual ethanol removed by tangential flow filtration.

[00701] A T-mixing process was developed to evaluate larger scale LNP batches and validate the reduced fouling with improved encapsulation efficiency. A brief schematic diagram and outline of the T-mix process is presented in Figure 5. Briefly the components included organic feed mRNA (OFM) Luc-TBA mRNA prepared as described herein, Ionizable Lipid – 1 (50 mol%), DSPC phospholipid (10 mol%), cholesterol structural lipid (38.5 mol%) and PEG-DMG PEG lipid (1.5 mol%). The process parameters included a 60 mL/min mRNA stream, a 20

mL/min lipid stream, a 30 minute hold prior to pH adjustment and a 5% by weight, 0.1 mL/s pH adjustment. Further modifications may be made to the setup including aqueous:ethanol ratio and organic solvents to solidify particles more rapidly, as well as dehydrate the organic phase during mixing. Consistent and desirable sizing and encapsulation efficiency values (EE%, RiboGreen assay) were obtained for the final lipid nanoparticle formulations (Table 2) and excellent correlation between encapsulation values calculated across additional assays was noted. A generally uniform particle morphology was observed with cryo-electron microscopy (cryo-EM) (Figure 6).

Table 2: Summary of organic feed T-mix LNPs using TBA-mRNA/DSPC/ Cholesterol/PEG-DMG/Ionizable Lipid - 1

Process Group	Size Diameter (nm)	PDI	%EE (RiboGreen)	mRNA Quant (mg/mL)
after mixing	74.96	0.212	-	-
after pH	82.72	0.257	-	-
Tmix + dialysis (1) in Figure 5	87.91	0.064	94.79	0.103
Tmix + in-line + dialysis (2) in Figure 5	69.96	0.143	97.27	0.019
after tangential flow filtration (TFF) (3) in Figure 5	70.17	0.096	94.91	0.235

96-well plate mixing of organic feed mRNA procedure

[00702] Organic soluble mRNA reduces the need for stringent mixing environments. Rapid parallel mixing and purification could significantly increase formulation screening bandwidth. Another organic soluble mRNA fed particle formulation employed high-throughput mixing to generate particles. In this manner, individual formulations were prepared having the same composition. Organic soluble mRNA was dissolved in an ethanol phase and particles were generated by simple mixing in a 96-well format. Each particle composition was identical and

contained 50 µg of mRNA. After formation, particle formulations may be pooled together and dialyzed against PBS.

[00703] The LNPs of this process were formed in stirring wells of a 96 well plate mixer (VP710E3) using tumble disc stirring at 800 rpm. Briefly, 0.412 mL of buffer (acetate buffer 6.25 mM, pH 5.0) was added to each well and stirred using the tumbling disc approach. An ethanol solution (0.137 mL) containing an mRNA-TBA salt (0.364 mg/mL) and cationic lipid (Ionizable Lipid - 1), cholesterol as structural lipid, helper lipids (DSPC) as phospholipid, and PEG lipids (PEG2K-DMG) (50:38.5:10:1.5 mole ratio) was added by manual pipette to the stirring aqueous solution to form the LNPs. Replicate wells (N = 20) were combined, and the resulting LNP containing solution was dialyzed at 4 °C against 4000 mL of PBS buffer and exchanged 2 times over 18 hours. The collected nanoparticles were tested for accessible mRNA using a Ribogreen quantification assay and particle sizing with DLS. Prior to in vivo dosing, particles were concentrated using centrifugal filter devices (Millipore Amicon Ultra 100 kDA MWCO, 4 °C). After concentrations, the sample was filtered (0.2 µm). Consistent and desirable sizing and encapsulation efficiency values (EE%, RiboGreen assay) were obtained for the final lipid nanoparticle formulations (Table 3). Further, in vitro expression for 96 well plate LNP formulation particles is comparable to vial stirring and NanoAssemblr formulations over both individual and pooled wells (Figure 7). It was additionally demonstrated that organic feed mRNA (OFM) is best suited for parallel mixing particle formation (Figure 8). Organic phase mRNA is more amenable to lower energy mixing than aqueous phase mRNA. High energy mixing (i.e. micro Tee, Gilson) shows no particle difference based on mRNA phase. Further, a fluorescence assay utilizing Laurdan indicated less surface disruption for high throughput 96-well plate mixing and T-mixing organic feed mRNA (OFM) sample formulations compared to an aqueous feed mRNA (AFM) NanoAssemblr mixing sample formulation. Fluorescence measurements suggest a less polar surface for OFM particles compared to traditional AFM particles.

Table 3: Summary of organic feed high-throughput 96-well mixing LNPs using TBA-mRNA/DSPC/ Cholesterol/PEG-DMG/Ionizable Lipid - 1

Process Description	Size (nm)	PDI	%EE (RiboGreen)	[mRNA] _{final} (µg/mL)	B _{max} (10 ⁶)
Aqueous Feed mRNA (AFM) – 96 well plate	197	0.15	76%	-	0.83

Organic Feed mRNA (OFM) – 96-well plate, A	89	0.09	96%	60	1.68
Organic Feed mRNA (OFM) – 96-well plate, B	89	0.07	96%	51	1.77
Organic Feed mRNA (OFM) – 96-well plate, C	95	0.06	96%	55	1.93
Organic Feed mRNA (OFM) – 96-well plate, Pooled	87	0.10	97%	58	1.56

Example 3: Luciferase (Luc) expression in mice after dosing with organic feed mRNA (OFM) formulated LNPs

In vivo formulation studies

[00704] In order to monitor how effectively various nanoparticle compositions deliver therapeutic and/or prophylactic agents to targeted cells, different nanoparticle compositions including a particular therapeutic and/or prophylactic agent (for example, a modified or naturally occurring RNA such as an mRNA) are prepared and administered to rodent populations. Mice are intravenously, intramuscularly, intraarterially, or intratumorally administered a single dose including a nanoparticle composition with a formulation such as those provided herein. In some instances, mice may be made to inhale doses. Dose sizes may range from 0.001 mg/kg to 10 mg/kg, where 10 mg/kg describes a dose including 10 mg of a therapeutic and/or prophylactic agent in a nanoparticle composition for each 1 kg of body mass of the mouse. A control composition including PBS may also be employed.

[00705] Upon administration of nanoparticle compositions to mice, dose delivery profiles, dose responses, and toxicity of particular formulations and doses thereof can be measured by enzyme-linked immunosorbent assays (ELISA), bioluminescent imaging, or other methods. For nanoparticle compositions including mRNA, time courses of protein expression can also be evaluated. Samples collected from the rodents for evaluation may include blood, sera, and tissue (for example, muscle tissue from the site of an intramuscular injection and internal tissue); sample collection may involve sacrifice of the animals.

[00706] Nanoparticle compositions including mRNA are useful in the evaluation of the efficacy and usefulness of various formulations for the delivery of therapeutic and/or prophylactic agents. Higher levels of protein expression induced by administration of a

composition including an mRNA will be indicative of higher mRNA translation and/or nanoparticle composition mRNA delivery efficiencies. As the non-RNA components are not thought to affect translational machineries themselves, a higher level of protein expression is likely indicative of higher efficiency of delivery of the therapeutic and/or prophylactic agent by a given nanoparticle composition relative to other nanoparticle compositions or the absence thereof.

[00707] The efficacy of nanoparticle compositions described herein was evaluated with a bioluminescence study. The study evaluated expression of organic feed LNP formulated Luciferase (Luc) mRNA in mice dosed intramuscularly (i.m.) or intravenously (i.v.). The study tested the expression and similarity of biodistribution in mice as compared to the standard aqueous feed LNP formulations. Formulations included Ionizable Lipid 1 and various organic soluble mRNA feed solutions produced by methods described herein employing organic soluble mRNA tributylamine (TBA) salts. Two organic soluble mRNA feed particle preparation methods (T-mix organic feed mRNA and 96-well plate mixing organic feed mRNA) for LNP formulation were compared to a traditional aqueous mRNA NanoAssemblr™ LNP formulation. Formulations were administered intramuscularly (i.m.) or intravenously (i.v.) to mice (female strain CD-1, 6 weeks, 20-22 g, n = 10) at a dosage of 0.1 mg/kg (mpk) intramuscularly and 0.5 mg/kg (mpk) intravenously. Expression of luciferase was evaluated at 6 hours (n = 5) and 24 hours (n = 5) post dosing by whole body and ex vivo IVIS imaging of liver, lung, spleen, and the site of injection for intramuscular administration. Blood was collected at 6 hours (n = 5) and 24 hours (n = 5) for cytokine analysis. The standard aqueous feed LNP formulation and a PBS control were evaluated for comparison.

Standard aqueous mRNA feed with NanoAssemblr™ mixing procedure (Comparative Control)

[00708] The comparative control process was a standard aqueous mRNA formulation generated using NanoAssemblr™ microfluidic mixing. This was a standard LNP process with standard aqueous feed mRNA (AFM) conditions. The aqueous phase contained mRNA and was buffered with acetate buffer (pH 5, 6.25 mM). Particles were formed using NanoAssemblr™ and dialyzed into PBS.

[00709] Lipid nanoparticles (LNPs) for the comparative control process were formed using a microfluidics mixing chamber (NanoAssemblr™) combining an aqueous solution of mRNA (0.121 mg/mL) in buffer (acetate buffer 6.25 mM, pH 5.0) with an ethanol solution containing

cationic lipid (Ionizable Lipid 1), cholesterol as structural lipid, helper lipids (DSPC) as phospholipid, and PEG lipids (PEG2K-DMG) (48:40.5:10:1.5 mole ratio) at a 3:1 volume ratio. The resulting LNP containing solution was dialyzed at 4 °C against 4000 mL of PBS buffer (pH 7.4) and exchanged 2 times over 18 hours. The collected nanoparticles were tested for accessible mRNA using Ribogreen quantification assay and particle sizing by dynamic light scattering (DLS). Prior to in vivo dosing, particles were concentrated using centrifugal filter devices (Millipore Amicon Ultra 100 kDA MWCO, 4 °C). After concentration, the sample was filtered (0.2 µm).

T-mixing procedure of organic feed mRNA procedure

[00710] A lipid stock containing a cationic lipid (Ionizable Lipid 1), cholesterol as structural lipid, helper lipid DSPC as phospholipid and PEG lipid in a molar ratio of 50:38.5:10:1.5 was mixed with mRNA dissolved in benzyl alcohol/ethanol. The organic feed containing lipids mRNA were loaded into a syringe and mixed in a volume ratio of 3:1 with sodium acetate using a PEEK T junction. An initial T-mix batch at a 5 mg scale was successfully run employing a Tech Dev apparatus. The T-mixed product (TMP) was inline diluted, adjusted to the desired final pH, and the mRNA-loaded lipid nanoparticles were concentrated, and residual ethanol removed by tangential flow filtration.

96-well plate mixing of organic feed mRNA procedure

[00711] A second organic soluble mRNA fed particle formulation employed high-throughput mixing to generate particles. In this manner, 20 individual formulations were prepared having the same composition. Organic soluble mRNA was dissolved in an ethanol phase and particles were generated by simple mixing in a 96-well format. Each particle composition was identical and contained 50 µg of mRNA. After formation, particle formulations were pooled together and dialyzed against PBS.

[00712] The LNPs of this process were formed in stirring wells of a 96 well plate mixer (VP710E3) using tumble disc stirring at 800 rpm. Briefly, 0.412 mL of buffer (acetate buffer 6.25 mM, pH 5.0) was added to each well and stirred using the tumbling disc approach. An ethanol solution (0.137 mL) containing an mRNA-TBA salt (0.364 mg/mL) and cationic lipid (Ionizable Lipid - 1), cholesterol as structural lipid, helper lipids (DSPC) as phospholipid, and PEG lipids (PEG2K-DMG) (48:40.5:10:1.5 mole ratio) was added by manual pipette to the stirring aqueous solution to form the LNPs. Replicate wells (N = 20) were combined, and the

resulting LNP containing solution was dialyzed at 4 °C against 4000 mL of PBS buffer and exchanged 2 times over 18 hours. The collected nanoparticles were tested for accessible mRNA using a Ribogreen quantification assay and particle sizing with DLS. Prior to in vivo dosing, particles were concentrated using centrifugal filter devices (Millipore Amicon Ultra 100 kDA MWCO, 4 °C). After concentrations, the sample was filtered (0.2 µm).

[00713] The size and PDI values looked consistent for all groups, even those prepared by 96-well plate mixing and pooling. Further, good encapsulation was observed across all groups as measured using the RiboGreen assay. Characterization of the formulations employed in this study are summarized in Table 4.

Table 4: Summary of LNP formulation methods and associated properties employed for in vivo bioluminescence study

Formulation	Process Description	Size (nm)	PDI	%EE (RiboGreen)
1	PBS control – Buffer only	-	-	-
2	Aqueous Feed mRNA (AFM) - NanoAssemblr™	96	0.11	94%
3	Organic Feed mRNA (OFM) – T-mix, TBA salt	78	0.13	94%
4	Organic Feed mRNA (OFM) – 96-well plate, TBA salt	110	0.07	93%

[00714] The experimental formulations administered intravenously and intramuscularly expressed well in vivo. The T-mixing formulation was comparable to traditional aqueous feed mRNA LNP formulations. The 96-well plate mixing formulation was approximately 10X lower but promising considering the simplicity of the mixing performed (Figure 9, Figure 10, Figures 11A-11D, Figures 12A-12D, Figures 13A-13C, Figures 14A-14D, Figure 15, Figure 16, Figures 17A-17D, Figures 18A-18D, Figures 19A-19D, Figures 20A-20D, Figures 21A-21D, and Figures 22A-22D).

[00715] All organic feed formulated LNPs dosed intramuscularly displayed luciferase expression in whole body imaging with the highest expression peaking at 6 hours that drops in signal by 24 hours (~ 1-1.5 logs). The T-mixing organic feed mRNA tributylamine (TBA) salt formulation resulted in comparable expression to the standard aqueous feed comparative control formulation whereas the 96-well plate mixing organic feed mRNA tributylamine (TBA) salt formulation displayed a slightly lower expression by whole body imaging (< 0.5 log). All

formulations tested displayed injection site, live, lung and spleen expression comparable to or lower than the standard aqueous feed comparative control formulation. In all formulations tested, expression peaked at 6 hours in all tissues imaged and showed drops in signal by 24 hours. In addition to comparable protein expression in intramuscularly treated mice between aqueous feed mRNA (AFM) (NanoAssemblr) and organic feed mRNA (OFM) (T-mix) there was also comparable cytokine induction for AFM-NanoAssemblr and OFM-Tmix particle formulations (Figure 23). The protein expression retained good correlation between in vitro (studied in primary mouse hepatocytes) and in vivo data (Figure 24). Aqueous feed mRNA (AFM) (NanoAssemblr) and organic feed mRNA (OFM) (T-mix) samples show similar expression at each concentration. The organic feed mRNA (OFM) (96 well) sample displays ~ 8-fold decrease in protein expression. The overall trends in expression in vitro match well with the in vivo data.

Example 4: Preparation of Lipid nanoparticles from various organic feed mRNA (OFM) salts exchanged into ethanol and solubilized by tangential flow filtration (TFF) with no lyophilization

[00716] To evaluate a new organic soluble mRNA process a tangential flow filtration (TFF) process was developed without the need for lyophilization. A conversion with cation exchange was performed via tangential flow filtration, followed by tangential flow filtration exchange into ethanol. The process was designed to eliminate the need for any benzyl alcohol in the ethanol solution to solubilize the lyophilized dried powder. Additionally, processes of this design enable faster turnaround times (hours as compared to days) to go from water soluble to organic soluble mRNA. Furthermore, these processes facilitate less hydrophobic cations (i.e. trimethylamine) which have proven more difficult to generate soluble mRNA using lyophilization/reconstitution procedures. Comparisons were made between various organic mRNA salts [triethylamine (TEA), tripropylamine (TPA), and tributylamine (TBA)] prepared using the tangential flow filtration (TFF). Acetate buffer (6.25 mM), pH 5) was used as aqueous phase. Ionizable Lipid - 1/DSPC/Cholesterol/PEG-DMG (50:10:38.5:1.5 mole ratio) was used as the lipid mix. The lipid nanoparticle was prepared by simple stir plate benchtop vial mixing (~ 1000 rpm) and dialyzed against 1×PBS with no filtering. Dynamic light scattering (DLS) measurements were taken after particle formation, dialysis and concentration.

Conversion to tributylamine (TBA) salt, tripropylamine (TPA) salt, and triethylamine (TEA) salt

[00717] A solution of 100 mM tributylammonium acetate (TBAA), tripropylammonium acetate (TPAA), or triethylammonium acetate (TEAA) in water was prepared by combining tributylamine, tripropylamine, or triethylamine, respectively, and acetic acid at a 1:1 molar ratio (i.e., final concentrations of 100 mM each) and bringing to volume with deionized water. The pH of the solution was expected to be approximately 6.0-6.5 when fully dissolved. The stock was then diluted to the working concentration of 10 mM with deionized water. The pre-treated mRNA was added to the reservoir of the tangential flow filtration (TFF) device and diluted approximately 5-fold with 10 mM TBAA, TPAA, or TEAA. The mRNA was incubated with the TBAA, TPAA, or TEA while recirculating in the cold TFF system for approximately 10 minutes. The mRNA was then washed with an additional 10 diavolumes of 10 mM TBAA. The mRNA-TBA, mRNA-TPA, or mRNA-TEA was exchanged into absolute ethanol by washing with 20 diavolumes, followed by collection of the mRNA-TBA, mRNA-TPA, or mRNA-TEA in ethanol, generally at concentrations of approximately 0.5 – 1.0 mg/mL.

Vial mixing of organic feed mRNA procedure

[00718] The organic phase contained cationic lipid (Ionizable Lipid - 1), cholesterol as structural lipid, helper lipid (DSPC) as phospholipid, and PEG lipid (PEG2K-DMG) in a 50:38.5:10:1.5 mole ratio and the organic-soluble mRNA salt (0.37 mg/mL mRNA in the TEA, TPA, or TBA salt form) in ethanol. The aqueous phase contained 6.25 mM acetate buffer, pH 5.0. LNPs were formed by nanoprecipitation: the organic phase was added to a vial containing aqueous buffer while stirring at 1000 rpm with a magnetic stir bar, at a volume ratio of 3:1 (aqueous to organic). The resulting LNP-containing solution was dialyzed at 4 °C against 4000 mL of PBS buffer (pH 7.4) and exchanged two times over 18 hours. The collected nanoparticles were tested for accessible mRNA using a Ribogreen quantification assay, and particle sizing was performed by DLS. Particles were concentrated using centrifugal filter devices (Millipore Amicon Ultra 100 kDa MWCO, 4 °C).

[00719] The sizing remains relatively uniform and around 100 nm with vial mixing (Figure 25 and Figure 26). Further, the encapsulation efficiency (%EE) as determined using RiboGreen assay remains high for all salt forms (Figure 27), the trends for %EE were maintained as measured Ribo* assay but demonstrated lower absolute values.

Example 5: Physiological pH formulations and aqueous solution flexibility with organic feed mRNA (OFM)

[00720] To investigate behavior of the lipid nanoparticle formulations at near physiological pH a study was performed on particle formation using either Tris/sucrose (pH ~7.3), 20 mM Tris 8% sucrose (pH ~7.4), or glucose (5% w/v, pH ~4.5) as aqueous phase comparing the organic (OFM) and aqueous (AFM) feed stocks of mRNA-TBA, DSPC/Cholesterol/PEG-DMG/Ionizable Lipid – 1 lipid mix (Table 5). The particle size, evaluated by DLS immediately after formation are all greater than 150 nm with good polydispersity. Reasonable encapsulation efficiency, size, and polydispersity was achieved from these simple mixing approaches. The good EE% maintained in glucose is likely due to lower pH (Figure 28). Additionally, particles were dialyzed against 1×PBS and mRNA encapsulation was reevaluated using the RiboGreen assay post-dialysis.

Table 5: Aqueous solution flexibility with organic feed mRNA (OFM)

mRNA form	Aqueous Phase	Size (nm)	PDI	%EE (RiboGreen) After dialysis
Organic	Tris/sucrose, pH 7.3	155	0.17	79%
	5% glucose, pH 4.5	181	0.16	86%
	25 mM acetate, pH 5	87.1	0.16	98%
	20 mM tris 8% sucrose, pH 7.4	65.4	0.10	98%
Aqueous	Tris/sucrose, pH 7.3	165	0.15	35%
	5% glucose, pH 4.5	187	0.17	70%
	25 mM acetate, pH 5	81.4	0.18	98%
	20 mM tris 8% sucrose, pH 7.4	185.2	0.52	36%

Example 6: Pilot in vivo study of bedside formulated lipid nanoparticles

[00721] The in vivo expression after intramuscular administration of LNPs prepared using a simplified benchtop nanoprecipitation method (K-syringe mixing) was evaluated for potential application as bedside formulations. The study included Ionizable Lipid 1 formulations that contain either organic soluble mRNA or standard aqueous soluble mRNA. Additionally, ethyl lauroyl arginate (EA-1) was used in some formulations to drive encapsulation without the requirement for an initial pH adjustment. The study compared the expression profile of discovery formulations to a standard Ionizable Lipid 1 LNP formulation. Due to the bedside

applications, these formulations contained residual solvent and were injected at a lower pH (~ 5). The study as designed included female Cd-1 mice (n =8 per group) treated intramuscularly (IM) with a 2 µg dose (~ 0.1 mpk). The standard formulations included Ionizable Lipid-1:DSPC:Cholesterol:PEG-DMG (50:10:38.5:1.5) with readouts including clinical observation at the injection site, EPO ELISA (3h, 6h, 24h) and cytokine levels (6h). Due to mixing volumes for syringe type, particles formed at an aqueous:organic ratio of 4:1. The organic feed mRNA (OFM) included hEPO TBA lyophilized and DMSO in contrast to the aqueous feed mRNA (AFM). The EA-1/DMSO was incorporated at N:P = 2. All bedside mixed groups were prepared ~ 24 h prior to dosing. The control formulation (1) was processed using standard workup procedures (i.e. NanoAssemblr mixing and dialysis prior to dosing). Bedside formulations were dosed without further processing or purification post mixing. All bedside formulations show good performance in vivo, with hEPO expression comparable to the NanoAssemblr control (See Figure 29 and Figure 30).

Table 6: Summary of LNP formulation methods and associated properties employed for in vivo bedside formulation study

Formulation	Process Description	Diameter (nm)	PDI	%EE (RiboGreen)	Apparent pH	% Organic (v/v) solvent in dose prep
1	NanoAssemblr control (1x PBS) – Buffer only	71	0.07	99%	7.02	-
2	Organic Feed mRNA (OFM) – (6.25 mM acetate 8% sucrose, pH 5)	64	0.10	99%	5.52	0.97% DMSO 10.1% ethanol
3	Organic Feed mRNA (OFM) – (20 mM tris 8% sucrose, pH 7.4) + EA-1	84	0.11	92%	7.40	1% DMSO 10.1% ethanol
4	Aqueous Feed mRNA (AFM) – (6.25 mM acetate 8% sucrose, pH 5)	71	0.08	98%	5.67	10.5% ethanol
5	Aqueous Feed mRNA (AFM) – (20 mM tris 8% sucrose, pH 7.4) + EA-1	92	0.15	92%	7.43	0.11% DMSO 11.6% ethanol

[00722] Small amounts of DMSO were required to solubilize the lyophilized TBA salt in groups 2 and 3, and the EA-1 in groups 3 and 5. This DMSO may be avoided in future studies. Values calculated based on 2 µg mRNA dose with 0.02 kg animal body weight assuming 100 mg/mL EA-1 in DMSO stock; 4.2 mg/mL hEPO TBA in DMSO stock. Groups 2-5 were diluted ~1.75x prior to dosing. Groups 2-5 contain ~11% ethanol at dosing concentration. Groups 2 and 4 were diluted with 6.25 mM acetate 8% sucrose, pH 5. Groups 3 and 5 were diluted with 20 mM tris 8% sucrose, pH 7.4

[00723] In summary, in vivo evaluation showed good hEPO expression for all point of care (“bedside”) formulated LNPs compared to NanoAssemblr mixed control particles. A dual syringe apparatus with inline static mixing produced LNPs with good particle properties (size, %EE, and PDI). Both organic and aqueous mRNA feedstocks were successful in vivo. The physical stability for particles and mRNA over 24 hours at 5 °C is good. The addition of ethyl lauroyl arginate (ELA) enabled formulation under physiological pH conditions for organic and aqueous mRNA. Further, the residual organic solvent levels did not adversely impact in vivo expression.

[00724] In addition the effect of mixing on LNP formulations and biological performance was examined to determine the influence of mixing stringency on the in vitro performance of lipid nanoparticles to correspond with the in vivo study. The study as designed included standard formulations including Ionizable Lipid-1:DSPC:Cholesterol:PEG-DMG (50:10:38.5:1.5), N:P 5.8. The OFM was hEPO TEA salt in EtOH and the AFM was untreated hEPO. The organic solvent was ethanol and the aqueous was 6.25 mM acetate, pH 5, the mixing volumes for syringe type result in particle formation at an aqueous:organic ratio of 4:1. The processing included dialyzing in 1X PBS, concentrating by centrifugal filtration and 0.2 µm filtered. All mixing strategies generate particles with good size and high %EE (RiboGreen), the AFM particles tend to be slightly smaller in diameter compared to OFM. The hEPO expression was tested in primary mouse hepatocyte cells and for all three mixing techniques, AFM outperformed OFM in vitro. The expression of AFM for K- and L-syringe mixing was comparable to that of the NanoAssemblr control, making these devices ideal for future studies (Figure 31, Figure 32, Figure 33, and Figure 34)

Table 7: Summary of LNP formulation methods and associated properties employed for in vivo bedside formulation study

Formulation	Mixing Technique	mRNA form	Diameter (nm)	PDI	%EE (RiboGreen)
1	NanoAssemblr	AFM	78	0.07	99%
2	96-well plate, pooled	AFM	109	0.11	99%
3	96-well plate, pooled	OFM	121	0.07	99%
4	K-syringe	AFM	78	0.11	99%
5	K-syringe	OFM	95	0.14	99%
6	L-syringe	AFM	90	0.08	98%
7	L-syringe	OFM	103	0.13	99%

Example 7: Dosing at pH 5 vs. 7.4 with varied N:P

[00725] Four unique bedside AFM formulations were generated by nanoprecipitation using AFM and static mixing 4:1 aqueous: organic at pH 5. Each hEPO mRNA formulation was dosed at either the acidic nanoprecipitation pH 5, and after neutralization to 1X pH 7.4 with PBS. A control formulation was also dosed at neutral pH. Table 8 shows the lipid concentrations in the ethanol phase during the nanoprecipitation, the % PEG_{2k} DMG, N:P ratio, and pH of the aqueous phase. Higher lipid stock concentrations result in higher output mRNA concentrations increasing the achievable dose in a bedside setting. Example compositions for groups 2 and 3 were: Ionizable Lipid-1:DSPC:Chol:PEG_{2k}-DMG 50:10:38.5:1.5. Groups 4 and 5 ratios were Ionizable Lipid-1:DSPC:Chol:PEG_{2k}-DMG 50:10:39.5:0.5. No purification post nanoprecipitation was performed for groups 2-9. The N:P ratio was adjusted for formulation 6-9 to determine the impact on performance. Formulations were held for 20 hrs at 5 °C and characterized prior to dosing. Particle characteristics are detailed in Table 8.

[00726] The Dose Prep Diluent corresponds to the buffer used diluting the samples prior to injection to achieve and mRNA dose of 2 µg per animal at the desired pH.

Table 8: Formulations characterization and dose preparation diluent

Group	Formulation Description	Dose Prep Diluent	Size (nm)	PDI	%EE (RiboGreen)
-------	-------------------------	-------------------	-----------	-----	-----------------

1	Standard Process LNP 1.5% PEG _{2k} - DMG	1x PBS, pH 7.4	80	0.18	99%
2	12.5 mM Stock Lipid, 1.5% PEG _{2k} -DMG, N:P 5.8	6.25 mM acetate 8% sucrose, pH 5	59	0.18	98%
3		1x PBS, pH 7.4	69	0.20	97%
4	40 mM Stock Lipid, 0.5% PEG _{2k} -DMG, N:P 5.8	6.25 mM acetate 8% sucrose, pH 5	75	0.22	98%
5		1x PBS, pH 7.4	132	0.09	97%
6	40 mM Stock Lipid, 0.5% PEG _{2k} -DMG, N:P 4	6.25 mM acetate 8% sucrose, pH 5	77	0.20	98%
7		1x PBS, pH 7.4	95	0.09	98%
8	40 mM Stock Lipid, 0.5% PEG _{2k} -DMG, N:P 3	6.25 mM acetate 8% sucrose, pH 5	93	0.14	97%
9		1x PBS, pH 7.4	100	0.09	97%

[00727] An in vivo study was conducted using female CD-1 mice (n=5) dosed IM at 2 µg per animal. Cytokines were analyzed at 6 hr, and hEPO levels were measured at 6 and 24 hrs (Figures 35–38). Formulations which were neutralized to pH 7.4 with PBS expressed more hEPO than those dosed at pH 5 across all the study groups. This trend held for both the 6 and 24 hr time points. Decreases cytokines were also observed with neutralized formulations except for IP10. Group 10 is a 1X PBS. The cytokine response from CD-1 mice at 6 hours comparing dosing pH on formulations and N:P ratio is shown in Figures 39A–39C.

Example 8: Neutral pH Formulation Comparison

[00728] The impact of dosing pH observed in Example 7 highlighted the benefit afforded by neutral pH dosing with aqueous feed mRNA (AFM). Acidic formulation procedures would require an additional neutralization step complicating point of use or bedside applications. Cations with pKa values higher than pH 7.4 remove the need for acidification during nanoprecipitation, eliminating the need for neutralization prior to dosing. The EA-5 and EA-13 cations used in the neutral pH formulations are shown in Figure 40.

[00729] LNPs were generated using the bedside static mixing approach (groups 2-5) under the conditions described in Example 7 and formulation specifics described in Table 9 with

characterization data shown for time 0 and after a 20 hr hold at 5 °C. Female CD-1 mice (n=5) were dosed 2 µg of hEPO mRNA in with cytokines read at 6 hr and hEPO at 6 and 24hr. The LNP control made using traditional nanoprecipitation procedures. Groups 4 and 5 had 2 charge equivalents relative to phosphates of either EA-5 or EA-13 added in addition to the 5.8 N:P of traditional cationic lipid.

Table 9: Formulation description and characterization data at time zero

Group	Formulation Description	Size (nm)	PDI	%EE (RiboGreen)
1	Standard Process LNP	79	0.09	99%
2/3	40 mM Lipid Stock, 0.5% PEG _{2k} -DMG, pH 5	75	0.10	100%
4	40 mM Lipid Stock, 0.5% PEG _{2k} -DMG, pH 7.4 EA-13	95	0.18	100%
5	40 mM Lipid Stock, 0.5% PEG _{2k} -DMG, pH 7.4 EA-5	98	0.11	100%

[00730] Formulations were held at 5 °C for 20 hours before dosing Table 10. Groups 2 and 3 were generated from the same pH 5 nanoprecipitation with group 3 split off and neutralized to pH 7.4 with PBS. Formulations were characterized again prior to dosing. A tris sucrose solution matching the neutral pH formulation diluent was also dosed as a control.

Table 10: Formulation description and characterization data after a 20 hr hold at 5 °C prior to dosing

Group	Formulation Description	Size (nm)	PDI	%EE (RiboGreen)
1	Standard Process LNP	82	0.08	98%
2	40 mM Lipid Stock, 0.5% PEG _{2k} -DMG, pH 5	88	0.07	99%

3	40 mM Lipid Stock, 0.5% PEG _{2k} - DMG, pH 5 → 7.4 (Neutralized)	125	0.09	98%
4	40 mM Lipid Stock, 0.5% PEG _{2k} -DMG, pH 7.4 EA-13	95	0.16	99%
5	40 mM Lipid Stock, 0.5% PEG _{2k} - DMG, pH 7.4 EA-5	98	0.14	99%

[00731] An in vivo study was conducted using female CD-1 mice (n=5) dosing 2 µg of hEPO mRNA IM at per animal. Cytokines were analyzed at 6 hr, and hEPO levels were measured at 6 (Figure 41) and 24 hrs (Figure 42). Group 3 formulations were neutralized to pH 7.4 prior to dosing while groups 4 and 6 were made and dosed at pH 7.4. The cytokine response from CD-1 mice at 6 hours comparing formulation process and high pKa lipid addition is shown in Figures 43A–43C.

[00732] Expression remained high for formulations dose at neutral pH, including formulations made at pH 7.4 in the presence of the higher pKa lipid.

Example 9: Direct pH Formulation Screening EA-III series

[00733] Additional high pKa lipids (Figure 44) were screened to determine suitable properties for aqueous feed mRNA (AFM), neutral pH, and static mixing bedside formulation procedures designed to enable bedside formulation of mRNA. Neutral pH formulation conditions outlined in example 8 were employed to formulate hEPO mRNA. Formulation mole ratios were Ionizable Lipid-1:DSPC:Chol:PEG_{2k}-DMG 50:10:38.5:1.5 or Ionizable Lipid-1:DSPC:Chol:PEG_{2k}-DMG 50:10:39.5:0.5 depending on PEG_{2k}-DMG levels, with 2 charge equivalents of higher pKa cation (Figure 44) added relative to mRNA phosphate input.

Table 11: Formulation descriptions and characterization at time = 0

Group	Formulation Description	Size (nm)	PDI	%EE (RiboGreen)
1	Standard Process LNP	93	0.19	96%

2	12.5 mM Lipid Stock, 1.5% PEG _{2k} - DMG, EA-1	82	0.22	96%
3	40 mM Lipid Stock, 1.5% PEG _{2k} - DMG, EA-12	74	0.14	100%
4	40 mM Lipid Stock, 0.5% PEG _{2k} - DMG, EA-12	88	0.20	100%
5	40 mM Lipid Stock, 1.5% PEG _{2k} - DMG, EA-13	65	0.09	100%
6	40 mM Lipid Stock, 0.5% PEG _{2k} - DMG, EA-13	85	0.14	100%
7	40 mM Lipid Stock, 1.5% PEG _{2k} - DMG, EA-14	78	0.13	99%
8	40 mM Lipid Stock, 0.5% PEG _{2k} - DMG, EA-14	92	0.15	100%

Table 12: Formulation descriptions and characterization prior to dosing after 20 hr at 5 °C.

Group	Formulation Description	Size (nm)	PDI	%EE (RiboGreen)
1	Standard Process LNP	116	0.17	98%
2	12.5 mM Lipid Stock, 1.5% PEG _{2k} -DMG, EA-1	81	0.20	96%
3	40 mM Lipid Stock, 1.5% PEG _{2k} - DMG, EA-12	73	0.13	99%
4	40 mM Lipid Stock, 0.5% PEG _{2k} - DMG, EA-12	88	0.14	100%
5	40 mM Lipid Stock, 1.5% PEG _{2k} - DMG, EA-13	70	0.12	100%
6	40 mM Lipid Stock, 0.5% PEG _{2k} - DMG, EA-13	90	0.13	100%
7	40 mM Lipid Stock, 1.5% PEG _{2k} - DMG, EA-14	83	0.17	100%
8	40 mM Lipid Stock, 0.5% PEG _{2k} - DMG, EA-14	95	0.17	100%

[00734] An in vivo study was conducted using female CD-1 mice (n=5) dosing 2ug hEPO mRNA IM at per animal. Expression levels for hEPO were measured at 6 (Figure 45) and 24 hrs (Figure 46) with cytokines analyzed at 6 hr (Figures 47A–47B). Group 9 is a 1X PBS control.

Example 10: Study 2869: CMV Example

[00735] The neutral pH bedside AFM nanoprecipitation technique was applied to validate their efficacy in a vaccine application. A cytomegalovirus (CMV) vaccine composed of 6 individual mRNA encoding both the pentamer protein complex (5 mRNA) and the gB protein (1 mRNA) was used.

[00736] All formulations, used the same propriety cationic lipid but differed in formulation process. Groups 1 and 2 were traditionally made LNPs which were manufactured in a traditional nanoprecipitation manner and purified before dosing according to industry norms. Groups 3 through 6 were made using the static mixing bedside nanoprecipitation process without purification prior to dosing. Groups 3 and 4 were dosed directly at pH 5 without neutralization. Groups 5 and 6 were constructed using the neutral pH bedside procedure through the addition of 2 charge equivalents of EA-1 as the high pKa encapsulation lipid.

[00737] Formulation mole ratios for groups 3 through 6 were Ionizable Lipid-1:DSPC:Chol:PEG_{2k}-DMG 50:10:38.5:1.5 or Ionizable Lipid-1:DSPC:Chol:PEG_{2k}-DMG 50:10:39.5:0.5 depending on PEG_{2K}-DMG levels, with 2 charge equivalents of higher pKa cation EA-1 added for groups 5 and 6.

[00738] Female BALB/c mice (n=8) were administered 2.5 ug/dose of CMV mRNA IM. Doses were administered on day 1 and day 22 (Figure 48). CMV pentamer and gB ELISA were performed on days 21 and 36. All bedside doses were prepared fresh the day before dosing and held at 5 °C for 24 hours. Mice were bled 3 weeks post prime (Day 21), and 2 weeks post boost (Day 36) to measure pentamer and gB titers.

Table 13: Dose1 formulation description and characterization at time zero

Group	Formulation Description	Size (nm)	PDI	%EE Ribogreen
1	Standard Process 1.5% PEG _{2k} -DMG	66	0.18	-
2	Standard Process 2	100	0.11	-

3	Bedside pH 5, 1.5% PEG _{2k} -DMG	69	0.10	99%
4	Bedside pH 5, 0.5% PEG _{2k} -DMG	89	0.12	100%
5	Bedside pH 7.4, 1.5% PEG _{2k} -DMG + EA-1	94	0.08	94%
6	Bedside pH 7.4, 0.5% PEG + EA-1	144	0.15	99%

Table 14: Dose 1 formulation description and characterization prior to dosing after a 24 hr 5 °C hold

Group	Formulation Description	Size (nm)	PDI	%EE Ribogreen
1	Standard Process 1.5% PEG _{2k} -DMG	80	0.21	99%
2	Standard Process 2	107	0.05	98%
3	Bedside pH 5, 1.5% PEG _{2k} -DMG	75	0.05	99%
4	Bedside pH 5, 0.5% PEG _{2k} -DMG	97	0.09	100%
5	Bedside pH 7.4, 1.5% PEG _{2k} -DMG + EA-1	80	0.14	98%
6	Bedside pH 7.4, 0.5% PEG PEG _{2k} + EA-1	122	0.14	99%

[00739] Dose 2 was prepared in a similar manner to dose 1.

Table 15 Example 10 Dose 2 formulation description and characterization at time zero

Group	Formulation Description	Size (nm)	PDI	%EE Ribogreen
1	Standard Process 1.5% PEG _{2k} -DMG	66	0.18	-
2	Standard Process 2	100	0.11	-
3	Bedside pH 5, 1.5% PEG _{2k} -DMG	69	0.10	99%
4	Bedside pH 5, 0.5% PEG _{2k} -DMG	89	0.12	100%

5	Bedside pH 7.4, 1.5% PEG _{2k} -DMG + EA-1	94	0.08	94%
6	Bedside pH 7.4, 0.5% PEG _{2k} + EA-1	144	0.15	99%

Table 16: Dose 2 formulation description and characterization prior to dosing after a 24 hr 5 °C hold

Group	Formulation Description	Size (nm)	PDI	%EE Ribogreen
1	Standard Process 1.5% PEG _{2k} -DMG	80	0.21	99%
2	Standard Process 2	107	0.05	98%
3	Bedside pH 5, 1.5% PEG _{2k} -DMG	75	0.05	99%
4	Bedside pH 5, 0.5% PEG _{2k} -DMG	97	0.09	100%
5	Bedside pH 7.4, 1.5% PEG _{2k} -DMG + EA-1	80	0.14	98%
6	Bedside pH 7.4, 0.5% PEG _{2k} + EA-1	122	0.14	99%

[00740] Large particle count measurements were taken for dose 2 at 0 and 24 hours. Particles >0.8 µm are shown in Figure 49, and >2 µm in Figure 50.

[00741] The ELISA titers for the pentamer (Figure 51) and the gB protein (Figure 52) showed immunological responses across all formulations including those prepared with acidic or neutral bedside nanoprecipitation processes.

Example 11: Bedside Nanoprecipitation for Personalized Vaccination

[00742] Bedside aqueous feed mRNA (AFM) nanoprecipitation could reduce times and costs associated with personalized treatments such as patient specific cancer or other vaccines. To validate the biological performance of formulations generated using the bedside nanoprecipitation process, a known murine epitope construct was formulated and tested for construct specific immune responses.

[00743] Three bedside nanoprecipitation formulations made with the static mixing approach were compared to a standard formulation containing the same mRNA construct, and an empty

lipid nanoparticle formulation absent any mRNA. Both acidic (pH 5) and neutral (pH 7.4) bedside formulations were tested. Formulations contained the following compositions Ionizable Lipid-1:DSPC:Chol:PEG_{2k}-DMG at N:P 5.8 and lipid mole ratios of 50:10:38.5:1.5 or 50:10:39.5:0.5 depending on PEG levels and EA-1 added at 2 charge equivalents relative to mRNA phosphates for neutral pH formulations. EA-1 was dissolved in DMSO prior to addition to the lipid mix. The final DMSO concentration when dosed was <0.1% by volume.

Table 1: Formulation, process, and dosing descriptions

Group	Process and Formulation Description	n	Total Dose (µg)	Dose Prep Diluent
1	No mRNA LNP control	2	10	0.9 N saline
2	Standard Process	6	10	0.9 N saline
3	Bedside pH 5, 0.5% PEG _{2k} -DMG	6	10	6.25 mM acetate 8% sucrose, pH 5
4	Bedside, pH 5, 1.5% PEG _{2k} -DMG	6	10	6.25 mM acetate 8% sucrose, pH 5
5	Bedside pH 7.4 + EA-1, 1.5% PEG _{2k} -DMG	6	10	20 mM tris 8% sucrose, pH 7.4

[00744] Female Bl/6 mice were given 2 doses (day 1, 8) of 5 ug/dose (split into 2.5 ug/quad/dose) IM (Figure 53). Diluents for each are noted in Table 1. Cytokines were read 6 hr post each dosing with IFN γ ELISpot analysis for three Class I cancer antigens (CA-A, CA-B, and CA-C) (Figure 54), as well as two Class II cancer antigens (CA-D, and CA-E) (Figure 55).

Table 28: Dose 1 Formulation Characterization

Group	Process and Formulation Description	Size (nm)	PDI	%EE Ribogreen
3	Bedside pH 5, 0.5% PEG _{2k} -DMG	71	0.17	99%
4	Bedside, pH 5, 1.5% PEG _{2k} -DMG	73	0.13	99%
5	Bedside pH 7.4 + EA-1, 1.5% PEG _{2k} -DMG	88	0.17	97%

Table 3: Dose 2 Formulation Characterization

Group	Process and Formulation Description	Size (nm)	PDI	%EE Ribogreen
-------	-------------------------------------	-----------	-----	---------------

3	Bedside pH 5, 0.5% PEG _{2k} -DMG	87	0.14	100%
4	Bedside, pH 5, 1.5% PEG _{2k} -DMG	79	0.11	99%
5	Bedside pH 7.4 + EA-1, 1.5% PEG _{2k} -DMG	81	0.18	97%

Example 12: Low and no PEG LNP by bedside nanoprecipitation

[00745] Lipid nanoparticles with reduced PEG coverage or no PEG input were formulated to determine if the short stability window needed for bedside nanoprecipitation procedures lessens the need for steric stabilizers like PEG in the formulation.

[00746] Bedside nanoprecipitation formulation made with the static mixing approach under the acidic (pH 5 conditions) were compared to a standard formulation. Formulations were dose either in acidic (pH 5) diluent or neutralized with PBS (pH 7.4) prior to dosing. Formulations contained the following compositions Ionizable Lipid-1:DSPC:Chol: (PEG_{2k}-DMG or PEG-Substitute) at N:P 5.8 and lipid mole ratios of 50:10:39.5:0.5. Three PEG_{2k}-DMG replacements were screened: Brij C2, Brij O2, and Cetyl Alcohol. Final ethanol concentrations were diluted to ~8% by volume prior to dosing. Formulation descriptions and dosing diluent for each group are shown in Table along with the particle characterization data.

Table 20: Formulation descriptions for reduced PEG and no-PEG formulations dosed in vivo

Group	PEG _{2k} -DMG Replacement	Dose Prep Diluent	Size (nm)	PDI	[mRNA] (µg/mL)	%EE (Ribogreen)
1	Standard LNP Control	1x PBS, pH 7.4	77	0.06	110	99%
2	0.5% Brij C2	6.25 mM acetate 8% sucrose, pH 5	89	0.10	94	99%
3	0.5% Brij O2	6.25 mM acetate 8% sucrose, pH 5	91	0.13	90	99%
4	0.5% cetyl alcohol	6.25 mM acetate 8% sucrose, pH 5	92	0.11	104	99%
5	0.5% Brij C2	1x PBS, pH 7.4	108	0.10	93	98%
6	0.5% Brij O2	1x PBS, pH 7.4	110	0.07	90	98%
7	0.5% cetyl alcohol	1x PBS, pH 7.4	280	0.22	93	71%

[00747] Female CD-1 mice (n=5) were dosed IV at 0.5 mg/kg of luciferase mRNA with whole body (Figure 56), and ex vivo liver (Figure 57), spleen (Figure 58), and lung (Figure 59) readouts at 6 hrs. PBS was dosed as a control group.

Example 13: Bedside Nanoprecipitation N to P Ratio Screen with EA-13

[00748] Bedside nanoprecipitation formulations were made with the static mixing approach and EA-13 as a high pKa lipid to drive encapsulation. Formulations were nanoprecipitated and dosed at neutral pH. EA-13 was added to each formulation at 2 charge equivalents relative to mRNA phosphates. The EA-13 lipids used in the formulations in Example 13 are shown in Figure 60.

[00749] Female Cd-1 mice were dosed 2 ug hEPO mRNA IM with hEPO readouts at 6 (Figure 61) and 24 hours (Figure 62) and Cytokines at 6hr for IP10 (Figure 63) and MCP-1 (Figure 64).

Table 21: Characterization of Example 13 dosed formulations at time zero

Group	Formulation Description	Size (nm)	PDI	%EE (RiboGreen)
1	Standard LNP Control	79	0.09	99%
2	1.5% PEG _{2k} -DMG, N:P 5.8	70	0.16	99%
3	1.5% PEG _{2k} -DMG, N:P 5	72	0.12	99%
4	1.5% PEG _{2k} -DMG, N:P 4	78	0.06	99%
5	1.5% PEG _{2k} -DMG, N:P 3	85	0.08	99%

Table 22: Characterization of Example 13 dosed formulations after 20 hr at 5 °C

Group	Formulation Description	Size (nm)	PDI	%EE (RiboGreen)
1	Standard LNP Control	83	0.08	98%
2	1.5% PEG _{2k} -DMG, N:P 5.8	71	0.07	98%
3	1.5% PEG _{2k} -DMG, N:P 5	76	0.06	99%

4	1.5% PEG _{2k} -DMG, N:P 4	83	0.09	99%
5	1.5% PEG _{2k} -DMG, N:P 3	101	0.11	98%

Equivalents

[00750] The details of one or more embodiments of the invention are set forth in the accompanying description above. Although any methods and materials similar or equivalent to those described herein can be used in the practice or testing of the present disclosure, the preferred methods and materials are now described. Other features, objects, and advantages of the disclosure will be apparent from the description and from the claims. In the specification and the appended claims, the singular forms include plural referents unless the context clearly dictates otherwise. Unless defined otherwise, all technical and scientific terms used herein have the same meaning as commonly understood by one of ordinary skill in the art to which this disclosure belongs. All patents and publications cited in this specification are incorporated by reference.

[00751] The foregoing description has been presented only for the purposes of illustration and is not intended to limit the invention to the precise form disclosed, but by the claims appended hereto.

CLAIMS

1. A method of producing a lipid nanoparticle (LNP) composition, the method comprising:
 - i) mixing an aqueous buffer solution and an organic solution, thereby forming a lipid nanoparticle (LNP) formulation comprising a lipid nanoparticle (LNP) encapsulating a nucleic acid; and
 - ii) processing the lipid nanoparticle (LNP) formulation, thereby forming the lipid nanoparticle composition;wherein the organic solution comprises an organic solvent-soluble nucleic acid and an ionizable lipid in an organic solvent; and
wherein the organic solvent-soluble nucleic acid comprises a hydrophobic organic cation.
2. The method of claim 1, further comprising:
 - ia) converting a water-soluble salt of a nucleic acid to an organic solvent-soluble nucleic acid prior to the mixing, thereby forming the organic solvent-soluble nucleic acid.
3. The method of claim 2, further comprising:
 - iaa) lyophilizing the organic solvent-soluble nucleic acid after the converting.
4. The method of any one of the preceding claims, further comprising:
 - iaa) filtering the LNP formulation.
5. The method of any one of the preceding claims, wherein the processing removes an organic solvent from the LNP formulation.
6. The method of any one of the preceding claims, wherein the filtering is a tangential flow filtration (TFF).
7. The method of any one of the preceding claims, wherein the step of processing the LNP further comprises packing the LNP formulation.

8. The method of any one of the preceding claims, wherein the step of packing the LNP solution comprises one or more of the following steps:
 - iib) adding a cryoprotectant to the LNP formulation;
 - iic) lyophilizing the LNP formulation, thereby forming a lyophilized LNP composition;
 - iid) storing the LNP formulation or the lyophilized LNP composition; and
 - iie) adding a buffering solution to the LNP formulation or the lyophilized LNP composition, thereby forming the LNP composition.
9. The method of any one of the preceding claims, wherein the mixing comprises turbulent mixing.
10. The method of any one of the preceding claims, wherein the mixing comprises laminar mixing.
11. The method of any one of the preceding claims, wherein the mixing comprises microfluidic mixing.
12. The method of any one of the preceding claims, wherein the mixing is automated.
13. The method of any one of the preceding claims, wherein the mixing is not automated.
14. The method of any one of the preceding claims, wherein the mixing has a Reynolds number of less than 5.0×10^4 , less than 1.0×10^4 , less than 5.0×10^3 , or less than 2.5×10^3 .
15. The method of any one of the preceding claims, wherein the mixing has a Reynolds number of less than about 1000, less than about 500, or less than about 250.
16. The method of any one of the preceding claims, wherein the converting comprises at least one selected from the group consisting of a dialysis, a tangential flow filtration (TFF), employing a hydrophobic ion pairing reverse phase column, employing an ion exchange resin, and employing a size exclusion column.

17. The method of any one of the preceding claims, wherein the organic-solvent soluble nucleic acid is a tertiary amine salt.
18. The method of any one of the preceding claims, wherein the organic-solvent soluble nucleic acid is at least one selected from the group consisting of a tributylamine (TBA) salt, a tripropylamine (TPA), and a triethylamine (TEA) salt.
19. The method of any one of the preceding claims, wherein the water-soluble salt of a nucleic acid is selected from the group consisting of a sodium salt and a tris(hydroxymethyl)aminomethane (Tris) salt.
20. The method of any one of the preceding claims, wherein the aqueous buffer solution has a pH in a range of from about 4 to about 6, about 4.5 to about 5.5, or about 4.8 to about 5.2.
21. The method of any one of the preceding claims, wherein the organic solution has a pH in a range of from about 7.0 to about 9.0, about 7.0 to about 8.1, or about 7.1 to about 7.8, or about 7.2 to about 7.7, or about 7.3 to about 7.6, or about 7.4 to about 7.5
22. A method of administering a lipid nanoparticle (LNP) formulation to a patient, the method comprising:
- providing an aqueous solution having a first pH in a range of from about 7.0 to about 9.0 comprising a therapeutic and/or prophylactic agent in an aqueous buffer and an organic solution comprising an ionizable lipid and an encapsulation agent in an organic solvent;
 - forming a lipid nanoparticle formulation comprising a lipid nanoparticle encapsulating the therapeutic and/or prophylactic agent by mixing the aqueous solution and the organic solution such that the lipid nanoparticle formulation has a second pH in a range of from about 7.0 to about 9.0 and comprises at least 1% by volume of the organic solvent relative to the total volume of the lipid nanoparticle formulation; and
 - administering the lipid nanoparticle formulation to the patient less than about 72 hours after the mixing.

23. A method of administering a lipid nanoparticle (LNP) formulation to a patient, the method comprising:
- providing an aqueous solution having a first pH in a range of from about 4.5 to about less than 7.0 comprising a therapeutic and/or prophylactic agent in an aqueous buffer and an organic solution comprising an ionizable lipid in an organic solvent;
 - forming a lipid nanoparticle formulation comprising a lipid nanoparticle encapsulating the therapeutic and/or prophylactic agent by mixing the aqueous solution and the organic solution such that the lipid nanoparticle formulation has a second pH in a range of from about 4.5 to about less than 7.0 and comprises at least 1% by volume of the organic solvent relative to the total volume of the lipid nanoparticle formulation; and
 - administering the lipid nanoparticle formulation to the patient less than about 72 hours after the mixing.
24. A method of administering a lipid nanoparticle (LNP) formulation to a patient, the method comprising:
- providing an aqueous buffer solution having a first pH in a range of from about 7.0 to about 9.0 and an organic solution comprising an ionizable lipid, an encapsulation agent, and a therapeutic and/or prophylactic agent in an organic solvent;
 - forming a lipid nanoparticle formulation comprising a lipid nanoparticle encapsulating the therapeutic and/or prophylactic agent by mixing the aqueous buffer solution and the organic solution such that the lipid nanoparticle formulation has a second pH in a range of from about 7.0 to about 9.0 and comprises at least about 1% by volume of the organic solvent relative to the total volume of the lipid nanoparticle formulation; and
 - administering the lipid nanoparticle formulation to the patient less than about 72 hours after the mixing.
25. A method of administering a lipid nanoparticle (LNP) formulation to a patient, the method comprising:

providing an aqueous buffer solution having a first pH in a range of from about 4.5 to about less than 7.0 and an organic solution comprising an ionizable lipid and a therapeutic and/or prophylactic agent in an organic solvent;

forming a lipid nanoparticle formulation comprising a lipid nanoparticle encapsulating the therapeutic and/or prophylactic agent by mixing the aqueous buffer solution and the organic solution such that the lipid nanoparticle formulation has a second pH in a range of from about 4.5 to about less than 7.0 and comprises at least 1% by volume of the organic solvent relative to the total volume of the lipid nanoparticle formulation; and

administering the lipid nanoparticle formulation to the patient less than about 72 hours after the mixing.

26. The method of claim 19 or claim 21, wherein the first pH and the second pH are in a range of from about 7.0 to about 8.1, or about 7.1 to about 7.8, or about 7.2 to about 7.7, or about 7.3 to about 7.6, or about 7.4 to about 7.5.

27. The method of claim 20 or claim 22, wherein the first pH and the second pH are in a range of from about 4.5 to about 6.5, or about 4.6 to about 6.0, or about 4.8 to about 5.5.

28. The method of any one of the preceding claims, wherein the administering is performed less than about 72 hours after the mixing, preferably less than about 60 hours after the mixing, preferably less than about 48 hours after the mixing, preferably less than about 36 hours after the mixing, preferably less than about 24 hours after the mixing, preferably less than about 20 hours after the mixing, preferably less than about 16 hours after the mixing, preferably less than about 12 hours after the mixing, preferably less than about 8 hours after the mixing.

29. The method of any one of the preceding claims, wherein the administering is performed less than about 120 minutes after the mixing, preferably less than about 100 minutes after the mixing, preferably less than about 90 minutes after the mixing, preferably less than about 80 minutes after the mixing, preferably less than about 70 minutes after the mixing, preferably less than about 60 minutes after the mixing, preferably less than about 50 minutes after the mixing, preferably less than about 40 minutes after the mixing, preferably less than about 30 minutes

after the mixing, preferably less than about 20 minutes after the mixing, preferably less than about 15 minutes after the mixing, preferably less than about 10 minutes after the mixing.

30. The method of any one of the preceding claims, wherein the lipid nanoparticle formulation is not processed between the mixing and the administering.
31. The method of any one of the preceding claims, which does not comprise a pH adjustment between the mixing and the administering.
32. The method of any one of the preceding claims, wherein the lipid nanoparticle formulation is not filtered between the mixing and the administering.
33. The method of any one of the preceding claims, wherein the method further comprises receiving at a first inlet of a mixing and administration device the organic solution.
34. The method of any one of the preceding claims, wherein the method further comprises receiving at a second inlet of a mixing and administration device the aqueous buffer solution.
35. The method of any one of the preceding claims, wherein the mixing is performed at a mixer site of a mixing and administration device.
36. The method of any one of the preceding claims, wherein the lipid nanoparticle formulation is administered via an outlet of a mixing and administration device.
37. The method of any one of the preceding claims, wherein the providing, the forming, the mixing and the administering are all performed employing a single mixing and administration device.
38. The method of any one of the preceding claims, wherein the mixing and administration device comprises a double-barrel syringe.

39. The method of any one of the preceding claims, wherein the mixing and administration device comprises a least one selected from the group consisting of a K-syringe and a L-syringe.
40. The method of any one of the preceding claims, wherein the mixing and administration device comprises a static mixer at the mixer site.
41. The method of any one of the preceding claims, wherein the static mixer is a helical static mixer.
42. The method of any one of the preceding claims, wherein the pH of the aqueous buffer solution and the pH of the lipid nanoparticle formulation are about the same.
43. The method of any one of the preceding claims, wherein the lipid nanoparticle formulation comprises about 1% by volume to about 50% by volume of the organic solvent relative to the total volume of the lipid nanoparticle formulation, preferably about 2% by volume to about 45% by volume, preferably about 3% by volume to about 40% by volume, preferably about 4% by volume to about 35% by volume, preferably about 5% by volume to about 33% by volume of the organic solvent relative to the total volume of the lipid nanoparticle formulation.
44. The method of any one of the preceding claims, wherein the organic solvent is an alcohol.
45. The method of any one of the preceding claims, wherein the organic solvent is ethanol.
46. The method of any one of the preceding claims, wherein the organic solvent comprises a first organic solvent and a second organic solvent.
47. The method of any one of the preceding claims, wherein the first organic solvent is an alcohol and the second organic solvent is an alcohol.

48. The method of any one of the preceding claims, wherein the first organic solvent is ethanol and the second organic solvent is benzyl alcohol.
49. The method of any one of the preceding claims, wherein a wt/wt ratio of the first organic solvent to the second organic solvent is in a range of from about 100:1 to about 1:1, or about 50:1 to about 1:1, or about 20:1 to about 1:1, or about 10:1 to about 1:1.
50. The method of any one of the preceding claims, wherein the organic solution further comprises a wetting agent.
51. The method of any one of the preceding claims, wherein the wetting agent is an organic solvent.
52. The method of any one of the preceding claims, wherein the wetting agent is dimethyl sulfoxide (DMSO).
53. The method of any one of the preceding claims, wherein a wt/wt ratio of the wetting agent to the organic solvent is in a range of from about 1000:1 to about 1:1, or about 500:1 to about 5:1, or about 100:1 to about 10:1.
54. The method of any one of the preceding claims, wherein the aqueous buffer solution is at least one selected from the group consisting of an acetate buffer, citrate buffer, phosphate buffer, and a tris buffer.
55. The method of any one of the preceding claims, wherein the aqueous buffer solution further comprises a tonicity agent.
56. The method of any one of the preceding claims, wherein the tonicity agent is a sugar.
57. The method of any one of the preceding claims, wherein the sugar is sucrose.

58. The method of any one of the preceding claims, wherein the organic solution further comprises an encapsulation agent.

59. The method of any one of the preceding claims, wherein the encapsulation agent is a compound of Formula (EA-I):

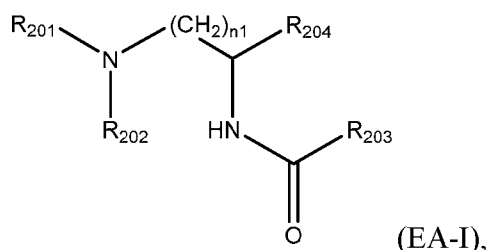

or salts or isomers thereof, wherein

R₂₀₁ and R₂₀₂ are each independently selected from the group consisting of H, C₁-C₆ alkyl, C₂-C₆ alkenyl, and (C=NH)N(R₁₀₁)₂ wherein each R₁₀₁ is independently selected from the group consisting of H, C₁-C₆ alkyl, and C₂-C₆ alkenyl;

R₂₀₃ is selected from the group consisting of C₁-C₂₀ alkyl and C₂-C₂₀ alkenyl;

R₂₀₄ is selected from the group consisting of H, C₁-C₂₀ alkyl, C₂-C₂₀ alkenyl, C(O)(OC₁-C₂₀ alkyl), C(O)(OC₂-C₂₀ alkenyl), C(O)(NHC₁-C₂₀ alkyl), and C(O)(NHC₂-C₂₀ alkenyl);

n₁ is selected from 1, 2, 3, 4, 5, 6, 7, 8, 9, and 10.

60. The method of any one of the preceding claims, wherein the encapsulation agent is a compound of Formula (EA-II):

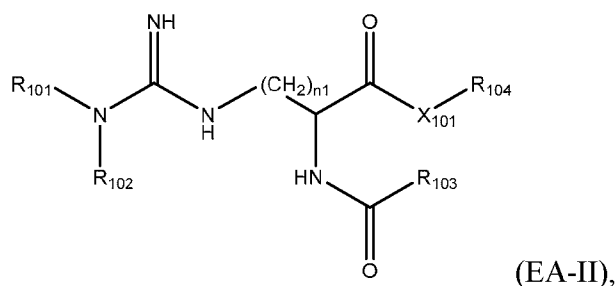

or salts or isomers thereof, wherein

X₁₀₁ is a bond, NH, or O;

R₁₀₁ and R₁₀₂ are each independently selected from the group consisting of H, C₁-C₆ alkyl, and C₂-C₆ alkenyl;

65. The method of any of the preceding claims, wherein the encapsulation agent is

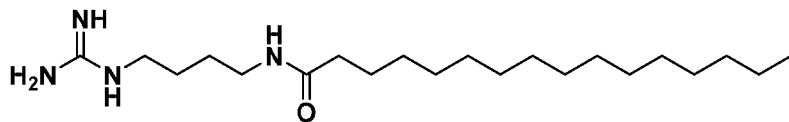

(EA-14), or a salt thereof.

66. The method of any of the preceding claims, wherein the encapsulation agent is

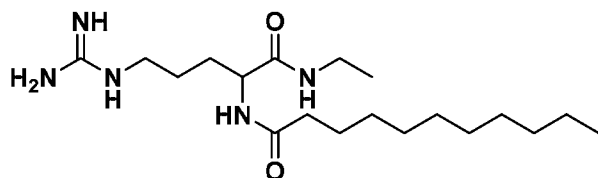

(EA-15), or a salt thereof.

67. The method of any of the preceding claims, wherein the encapsulation agent is

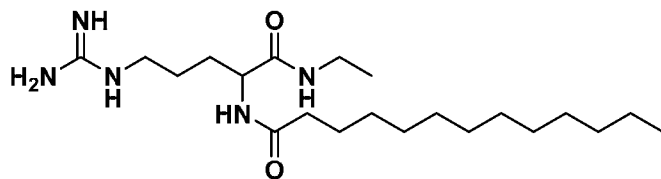

(EA-16), or a salt thereof.

68. The method of any of the preceding claims, wherein the encapsulation agent is

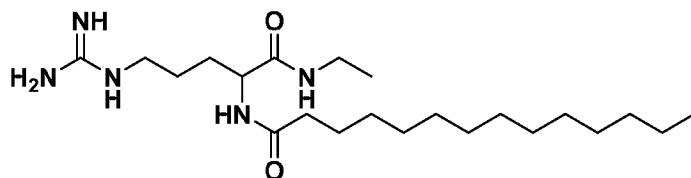

(EA-17), or a salt thereof.

69. The method of any of the preceding claims, wherein the encapsulation agent is

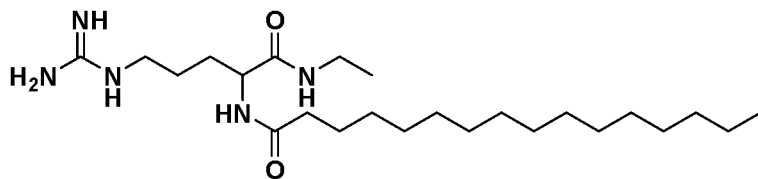

(EA-18), or a salt thereof.

70. The method of any one of the preceding claims, wherein the encapsulation agent is ethyl lauroyl arginate or a salt or isomer thereof.

71. The method of any one of the preceding claims, wherein the therapeutic and/or prophylactic agent is a vaccine or a compound capable of eliciting an immune response.
72. The method of any one of the preceding claims, wherein the therapeutic and/or prophylactic agent is a nucleic acid.
73. The method of any one of the preceding claims, wherein the nucleic acid is a ribonucleic acid (RNA).
74. The method of any one of the preceding claims, wherein the ribonucleic acid is at least one ribonucleic acid selected from the group consisting of a small interfering RNA (siRNA), an asymmetrical interfering RNA (aiRNA), a microRNA (miRNA), a Dicer-substrate RNA (dsRNA), a small hairpin RNA (shRNA), a messenger RNA (mRNA), and a long non-coding RNA (lncRNA).
75. The method of any one of the preceding claims, wherein the nucleic acid is a messenger RNA (mRNA).
76. The method of any one of the preceding claims, wherein the vaccine comprises a mRNA having an open reading frame encoding a cancer antigen
77. The method of any one of the preceding claims, wherein the vaccine is a personalized cancer vaccine and wherein the cancer antigen is a subject specific cancer antigen.
78. The method of any one of the preceding claims, wherein the vaccine further comprises a mRNA having an open reading frame encoding an immune checkpoint modulator.
79. The method of any one of the preceding claims, wherein the personalized cancer vaccine comprises an open reading frame encoding at least 2 cancer antigen epitomes.

80. The method of any one of the preceding claims, wherein the mRNA encodes 2-100 cancer antigens.
81. The method of any one of the preceding claims, wherein the mRNA encodes 10-100 cancer antigens.
82. The method of any one of the preceding claims, wherein the mRNA encodes 10-1000 cancer antigens.
83. The method of any one of the preceding claims, wherein the mRNA encodes one or more recurrent polymorphisms.
84. The method of any one of the preceding claims, wherein the recurrent polymorphisms comprise a recurrent somatic cancer mutation in p53.
85. The method of any one of the preceding claims, wherein the mRNA includes at least one motif selected from the group consisting of a stem loop, a chain terminating nucleoside, a polyA sequence, a polyadenylation signal, and a 5' cap structure.
86. The method of any one of the preceding claims, wherein the nucleic acid is suitable for a genome editing technique.
87. The method of any one of the preceding claims, wherein the genome editing technique is clustered regularly interspaced short palindromic repeats (CRISPR) or transcription activator-like effector nuclease (TALEN).
88. The method of any one of the preceding claims, wherein the nucleic acid is at least one nucleic acid suitable for a genome editing technique selected from the group consisting of a CRISPR RNA (crRNA), a trans-activating crRNA (tracrRNA), a single guide RNA (sgRNA), and a DNA repair template.

89. The method of any one of the preceding claims, wherein the mRNA is at least 30 nucleotides in length.
90. The method of any one of the preceding claims, wherein the mRNA is at least 300 nucleotides in length.
91. The method of any one of the preceding claims, wherein the wt/wt ratio of the LNP formulation and/or LNP composition to the nucleic acid is in a range from about 5:1 to about 60:1.
92. The method of any one of the preceding claims, wherein the wt/wt ratio of the LNP formulation and/or LNP composition to the nucleic acid is in a range from about 10:1 to about 50:1
93. The method of any one of the preceding claims, wherein the LNP further comprises a phospholipid, a PEG lipid, a structural lipid, an encapsulation agent or any combination thereof.
94. The method of any one of the preceding claims, wherein the LNP formulation and/or LNP composition further comprises a phospholipid, a PEG lipid, a structural lipid, an encapsulation agent or any combination thereof.
95. The method of any one of the preceding claims, wherein the organic solution further comprises a phospholipid, a PEG lipid, a structural lipid, or any combination thereof.
96. The method of any one of the preceding claims, wherein the LNP formulation and/or LNP composition comprises
- about 30-60 mol% ionizable lipid;
 - about 0-30 mol% phospholipid;
 - about 15-50 mol% structural lipid; and
 - about 0.01-10 mol% PEG lipid.

97. The method of any one of the preceding claims, wherein the LNP formulation and/or LNP composition comprises
- about 30-60 mol% ionizable lipid;
 - about 0-30 mol% phospholipid;
 - about 15-50 mol% structural lipid; and
 - about 0.01-2.5 mol% PEG lipid.
98. The method of any one of the preceding claims, wherein the LNP formulation and/or LNP composition comprises
- about 40-60 mol% ionizable lipid;
 - about 5-15 mol% phospholipid;
 - about 35-45 mol% structural lipid;
 - about 0.01-2.0 mol% PEG lipid.
99. The method of any one of the preceding claims, wherein the PEG lipid is selected from the group consisting of a PEG-modified phosphatidylethanolamine, a PEG-modified phosphatidic acid, a PEG-modified ceramide, a PEG-modified dialkylamine, a PEG-modified diacylglycerol, and a PEG-modified dialkylglycerol.
100. The method of any one of the preceding claims, wherein the PEG lipid is a compound of Formula (PL-I):

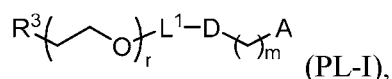

or salts thereof, wherein:

- R^3 is $-\text{OR}^0$;
- R^0 is hydrogen, optionally substituted alkyl, or an oxygen protecting group;
- r is an integer between 1 and 100, inclusive;
- L^1 is optionally substituted C_{1-10} alkylene, wherein at least one methylene of the optionally substituted C_{1-10} alkylene is independently replaced with optionally substituted carbocyclylene, optionally substituted heterocyclylene, optionally substituted arylene, optionally

substituted heteroarylene, O, N(R^N), S, C(O), C(O)N(R^N), NR^NC(O), C(O)O, OC(O), OC(O)O, OC(O)N(R^N), NR^NC(O)O, or NR^NC(O)N(R^N);

D is a moiety obtained by click chemistry or a moiety cleavable under physiological conditions;

m is 0, 1, 2, 3, 4, 5, 6, 7, 8, 9, or 10;

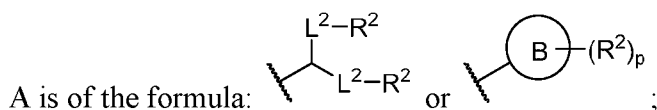

each instance of of L² is independently a bond or optionally substituted C₁₋₆ alkylene, wherein one methylene unit of the optionally substituted C₁₋₆ alkylene is optionally replaced with O, N(R^N), S, C(O), C(O)N(R^N), NR^NC(O), C(O)O, OC(O), OC(O)O, OC(O)N(R^N), NR^NC(O)O, or NR^NC(O)N(R^N);

each instance of R² is independently optionally substituted C₁₋₃₀ alkyl, optionally substituted C₁₋₃₀ alkenyl, or optionally substituted C₁₋₃₀ alkynyl; optionally wherein one or more methylene units of R² are independently replaced with optionally substituted carbocyclylene, optionally substituted heterocyclylene, optionally substituted arylene, optionally substituted heteroarylene, N(R^N), O, S, C(O), C(O)N(R^N), NR^NC(O), NR^NC(O)N(R^N), C(O)O, OC(O), -OC(O)O, OC(O)N(R^N), NR^NC(O)O, C(O)S, SC(O), C(=NR^N), C(=NR^N)N(R^N), NR^NC(=NR^N), NR^NC(=NR^N)N(R^N), C(S), C(S)N(R^N), NR^NC(S), NR^NC(S)N(R^N), S(O), OS(O), S(O)O, -OS(O)O, OS(O)₂, S(O)₂O, OS(O)₂O, N(R^N)S(O), S(O)N(R^N), N(R^N)S(O)N(R^N), OS(O)N(R^N), N(R^N)S(O)O, S(O)₂, N(R^N)S(O)₂, S(O)₂N(R^N), N(R^N)S(O)₂N(R^N), OS(O)₂N(R^N), or -N(R^N)S(O)₂O;

each instance of R^N is independently hydrogen, optionally substituted alkyl, or a nitrogen protecting group;

Ring B is optionally substituted carbocyclyl, optionally substituted heterocyclyl, optionally substituted aryl, or optionally substituted heteroaryl; and

p is 1 or 2.

101. The method of any one of the preceding claims, wherein the PEG lipid is a compound of Formula (PL-I-OH):

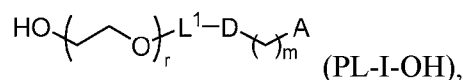

or a salt thereof.

102. The method of any one of the preceding claims, wherein the PEG lipid is a compound of Formula (PL-II):

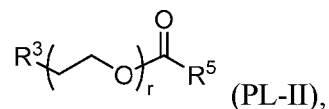

or a salt thereof, wherein:

R^3 is $-\text{OR}^0$;

R^0 is hydrogen, optionally substituted alkyl or an oxygen protecting group;

r is an integer between 1 and 100;

R^5 is optionally substituted C_{10-40} alkyl, optionally substituted C_{10-40} alkenyl, or optionally substituted C_{10-40} alkynyl; and optionally one or more methylene groups of R^5 are replaced with optionally substituted carbocyclene, optionally substituted heterocyclene, optionally substituted arylene, optionally substituted heteroarylene, $\text{N}(\text{R}^N)$, O, S, $\text{C}(\text{O})$, $\text{C}(\text{O})\text{N}(\text{R}^N)$, $-\text{NR}^N\text{C}(\text{O})$, $\text{NR}^N\text{C}(\text{O})\text{N}(\text{R}^N)$, $\text{C}(\text{O})\text{O}$, $\text{OC}(\text{O})$, $\text{OC}(\text{O})\text{O}$, $\text{OC}(\text{O})\text{N}(\text{R}^N)$, $\text{NR}^N\text{C}(\text{O})\text{O}$, $\text{C}(\text{O})\text{S}$, $\text{SC}(\text{O})$, $\text{C}(=\text{NR}^N)$, $\text{C}(=\text{NR}^N)\text{N}(\text{R}^N)$, $\text{NR}^N\text{C}(=\text{NR}^N)$, $\text{NR}^N\text{C}(=\text{NR}^N)\text{N}(\text{R}^N)$, $\text{C}(\text{S})$, $\text{C}(\text{S})\text{N}(\text{R}^N)$, $\text{NR}^N\text{C}(\text{S})$, $-\text{NR}^N\text{C}(\text{S})\text{N}(\text{R}^N)$, $\text{S}(\text{O})$, $\text{OS}(\text{O})$, $\text{S}(\text{O})\text{O}$, $\text{OS}(\text{O})\text{O}$, $\text{OS}(\text{O})_2$, $\text{S}(\text{O})_2\text{O}$, $\text{OS}(\text{O})_2\text{O}$, $\text{N}(\text{R}^N)\text{S}(\text{O})$, $-\text{S}(\text{O})\text{N}(\text{R}^N)$, $\text{N}(\text{R}^N)\text{S}(\text{O})\text{N}(\text{R}^N)$, $\text{OS}(\text{O})\text{N}(\text{R}^N)$, $\text{N}(\text{R}^N)\text{S}(\text{O})\text{O}$, $\text{S}(\text{O})_2$, $\text{N}(\text{R}^N)\text{S}(\text{O})_2$, $\text{S}(\text{O})_2\text{N}(\text{R}^N)$, $-\text{N}(\text{R}^N)\text{S}(\text{O})_2\text{N}(\text{R}^N)$, $\text{OS}(\text{O})_2\text{N}(\text{R}^N)$, or $\text{N}(\text{R}^N)\text{S}(\text{O})_2\text{O}$; and

each instance of R^N is independently hydrogen, optionally substituted alkyl, or a nitrogen protecting group.

103. The method of any one of the preceding claims, wherein the PEG lipid is a compound of Formula (PL-II-OH):

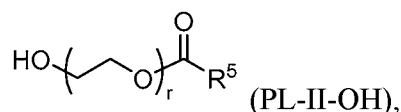

or a salt thereof, wherein:

r is an integer between 1 and 100;

R^5 is optionally substituted C_{10-40} alkyl, optionally substituted C_{10-40} alkenyl, or optionally substituted C_{10-40} alkynyl; and optionally one or more methylene groups of R^5 are replaced with

optionally substituted carbocyclylene, optionally substituted heterocyclylene, optionally substituted arylene, optionally substituted heteroarylene, $N(R^N)$, O, S, C(O), C(O) $N(R^N)$, - NR^N C(O), NR^N C(O) $N(R^N)$, C(O)O, OC(O), OC(O)O, OC(O) $N(R^N)$, NR^N C(O)O, C(O)S, SC(O), C(=NR^N), C(=NR^N) $N(R^N)$, NR^N C(=NR^N), NR^N C(=NR^N) $N(R^N)$, C(S), C(S) $N(R^N)$, NR^N C(S), - NR^N C(S) $N(R^N)$, S(O), OS(O), S(O)O, OS(O)O, OS(O)₂, S(O)₂O, OS(O)₂O, $N(R^N)$ S(O), -S(O) $N(R^N)$, $N(R^N)$ S(O) $N(R^N)$, OS(O) $N(R^N)$, $N(R^N)$ S(O)O, S(O)₂, $N(R^N)$ S(O)₂, S(O)₂ $N(R^N)$, - $N(R^N)$ S(O)₂ $N(R^N)$, OS(O)₂ $N(R^N)$, or $N(R^N)$ S(O)₂O; and

each instance of R^N is independently hydrogen, optionally substituted alkyl, or a nitrogen protecting group.

104. The method of any one of the preceding claims, wherein r is an integer between 40 and 50.

105. The method of any one of the preceding claims, wherein r is 45.

106. The method of any one of the preceding claims, wherein R^5 is C₁₇ alkyl.

107. The method of any one of the preceding claims, wherein the PEG lipid is a compound of Formula (PL-II) is:

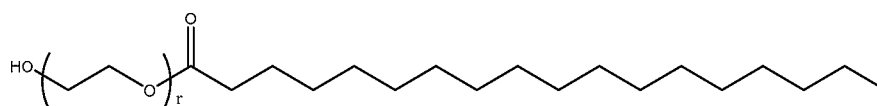

or a salt thereof.

108. The method of any one of the preceding claims, wherein the PEG lipid is a compound of Formula (PL-II) is

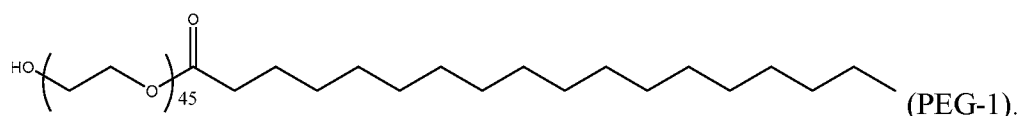

109. The method of any one of the preceding claims, wherein the PEG lipid is a compound of Formula (PL-III):

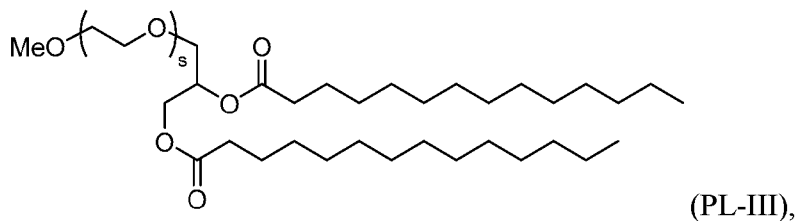

or a salt or isomer thereof, wherein s is an integer between 1 and 100.

110. The method of any one of the preceding claims, wherein the PEG lipid is a compound of following formula:

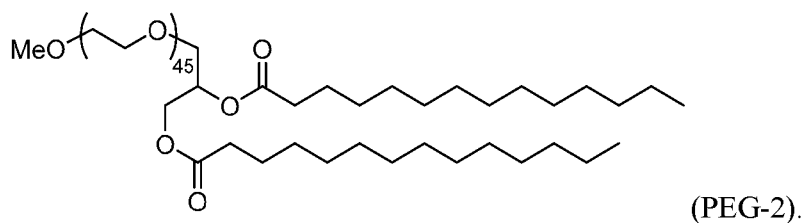

111. The method of any of the preceding claims, wherein the PEG lipid is a compound of Formula (PL-IV):

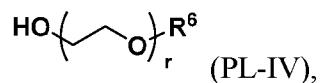

or salts thereof, wherein:

R^6 is C_1 - C_{20} alkyl;

r is an integer between 0 and 100, inclusive.

In some embodiments, r is 0.

In some embodiments, R^6 is C_{16} alkyl.

In some embodiments, R^6 is C_{18} alkyl.

112. The method of any of the preceding claims, wherein the PEG lipid is

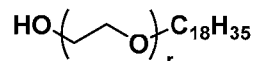

113. The method of any of the preceding claims, wherein the PEG lipid is

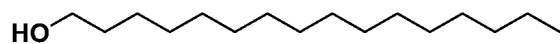

114. The method of any one of the preceding claims, wherein the structural lipid is selected from the group consisting of cholesterol, fecosterol, sitosterol, ergosterol, campesterol, stigmasterol, brassicasterol, tomatidine, ursolic acid, alpha-tocopherol, and derivatives thereof.

115. The method of any one of the preceding claims, wherein the phospholipid is selected from the group consisting of 1,2-dilinoleoyl-sn-glycero-3-phosphocholine (DLPC), 1,2-dimyristoyl-sn-glycero-phosphocholine (DMPC), 1,2-dioleoyl-sn-glycero-3-phosphocholine (DOPC), 1,2-dipalmitoyl-sn-glycero-3-phosphocholine (DPPC), 1,2-distearoyl-sn-glycero-3-phosphocholine (DSPC), 1,2-diundecanoyl-sn-glycero-phosphocholine (DUPC), 1-palmitoyl-2-oleoyl-sn-glycero-3-phosphocholine (POPC), 1,2-di-O-octadecenyl-sn-glycero-3-phosphocholine (18:0 Diether PC), 1-oleoyl-2-cholesterylhemisuccinoyl-sn-glycero-3-phosphocholine (OChemPC), 1-hexadecyl-sn-glycero-3-phosphocholine (C16 Lyso PC), 1,2-dilinolenoyl-sn-glycero-3-phosphocholine, 1,2-diarachidonoyl-sn-glycero-3-phosphocholine, 1,2-didocosahexaenoyl-sn-glycero-3-phosphocholine, 1,2-dioleoyl-sn-glycero-3-phosphoethanolamine (DOPE), 1,2-diphytanoyl-sn-glycero-3-phosphoethanolamine (ME 16.0 PE), 1,2-distearoyl-sn-glycero-3-phosphoethanolamine, 1,2-dilinoleoyl-sn-glycero-3-phosphoethanolamine, 1,2-dilinolenoyl-sn-glycero-3-phosphoethanolamine, 1,2-diarachidonoyl-sn-glycero-3-phosphoethanolamine, 1,2-didocosahexaenoyl-sn-glycero-3-phosphoethanolamine, 1,2-dioleoyl-sn-glycero-3-phospho-rac-(1-glycerol) sodium salt (DOPG), sphingomyelin, and derivatives thereof.

116. The method of any one of the preceding claims, wherein the phospholipid is 1,2-distearoyl-sn-glycero-3-phosphocholine (DSPC).

117. The method of any one of the preceding claims, wherein the ionizable lipid comprises an ionizable amino lipid.

118. The method of any one of the preceding claims, wherein the ionizable lipid is a compound of Formula (IL-1):

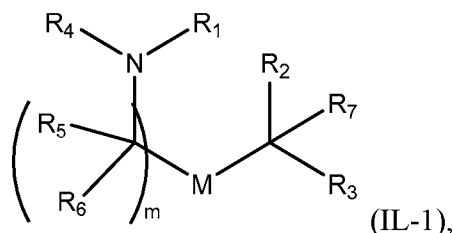

or their N-oxides, or salts or isomers thereof, wherein:

R₁ is selected from the group consisting of C₅₋₃₀ alkyl, C₅₋₂₀ alkenyl, -R*YR'', -YR'', and -R''M'R';

R₂ and R₃ are independently selected from the group consisting of H, C₁₋₁₄ alkyl, C₂₋₁₄ alkenyl, -R*YR'', -YR'', and -R*OR'', or R₂ and R₃, together with the atom to which they are attached, form a heterocycle or carbocycle;

R₄ is selected from the group consisting of hydrogen, a C₃₋₆ carbocycle, -(CH₂)_nQ, -(CH₂)_nCHQR, -CHQR, -CQ(R)₂, and unsubstituted C₁₋₆ alkyl, where Q is selected from a carbocycle, heterocycle, -OR, -O(CH₂)_nN(R)₂, -C(O)OR, -OC(O)R, -CX₃, -CX₂H, -CXH₂, -CN, -N(R)₂, -C(O)N(R)₂, -N(R)C(O)R, -N(R)S(O)₂R, -N(R)C(O)N(R)₂, -N(R)C(S)N(R)₂, -N(R)R₈, N(R)S(O)₂R₈, -O(CH₂)_nOR, -N(R)C(=NR₉)N(R)₂, -N(R)C(=CHR₉)N(R)₂, -OC(O)N(R)₂, -N(R)C(O)OR, -N(OR)C(O)R, -N(OR)S(O)₂R, -N(OR)C(O)OR, -N(OR)C(O)N(R)₂, -N(OR)C(S)N(R)₂, -N(OR)C(=NR₉)N(R)₂, -N(OR)C(=CHR₉)N(R)₂, -C(=NR₉)N(R)₂, -C(=NR₉)R, -C(O)N(R)OR, and -C(R)N(R)₂C(O)OR, and each n is independently selected from 1, 2, 3, 4, and 5;

each R₅ is independently selected from the group consisting of C₁₋₃ alkyl, C₂₋₃ alkenyl, and H;

each R₆ is independently selected from the group consisting of C₁₋₃ alkyl, C₂₋₃ alkenyl, and H;

M and M' are independently selected from -C(O)O-, -OC(O)-, -OC(O)-M'-C(O)O-, -C(O)N(R')-, -N(R')C(O)-, -C(O)-, -C(S)-, -C(S)S-, -SC(S)-, -CH(OH)-, -P(O)(OR')O-, -S(O)₂-, -S-S-, an aryl group, and a heteroaryl group, in which M' is a bond, C₁₋₁₃ alkyl or C₂₋₁₃ alkenyl;

R₇ is selected from the group consisting of C₁₋₃ alkyl, C₂₋₃ alkenyl, and H;

R₈ is selected from the group consisting of C₃₋₆ carbocycle and heterocycle;

R₉ is selected from the group consisting of H, CN, NO₂, C₁₋₆ alkyl, -OR, -S(O)₂R, -S(O)₂N(R)₂, C₂₋₆ alkenyl, C₃₋₆ carbocycle and heterocycle;

each R is independently selected from the group consisting of C₁₋₃ alkyl, C₂₋₃ alkenyl, and H;

each R' is independently selected from the group consisting of C₁₋₁₈ alkyl, C₂₋₁₈ alkenyl, -R*YR'', -YR'', and H;

each R'' is independently selected from the group consisting of C₃₋₁₅ alkyl and C₃₋₁₅ alkenyl;

each R* is independently selected from the group consisting of C₁₋₁₂ alkyl and C₂₋₁₂ alkenyl;

each Y is independently a C₃₋₆ carbocycle;

each X is independently selected from the group consisting of F, Cl, Br, and I; and

m is selected from 5, 6, 7, 8, 9, 10, 11, 12, and 13; and wherein when R₄ is -(CH₂)_nQ, -(CH₂)_nCHQR, -CHQR, or -CQ(R)₂, then (i) Q is not -N(R)₂ when n is 1, 2, 3, 4 or 5, or (ii) Q is not 5, 6, or 7-membered heterocycloalkyl when n is 1 or 2.

119. The method of any one of the preceding claims, wherein the ionizable lipid is a compound of Formula (IL-IA):

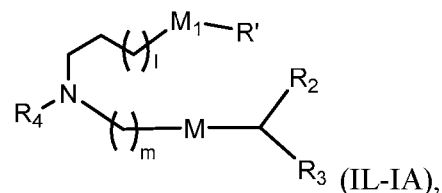

or its N-oxide, or a salt or isomer thereof, wherein l is selected from 1, 2, 3, 4, and 5; m is selected from 5, 6, 7, 8, and 9; M₁ is a bond or M'; R₄ is hydrogen, unsubstituted C₁₋₃ alkyl, or -(CH₂)_nQ, in which Q is OH, -NHC(S)N(R)₂, -NHC(O)N(R)₂, -N(R)C(O)R, -N(R)S(O)₂R, -N(R)R₈, -NHC(=NR₉)N(R)₂, -NHC(=CHR₉)N(R)₂, -OC(O)N(R)₂, -N(R)C(O)OR, heteroaryl or heterocycloalkyl; M and M' are independently selected from -C(O)O-, -OC(O)-, -OC(O)-M'-C(O)O-, -C(O)N(R')-, -P(O)(OR')O-, -S-S-, an aryl group, and a heteroaryl group; and R₂ and R₃ are independently selected from the group consisting of H, C₁₋₁₄ alkyl, and C₂₋₁₄ alkenyl.

120. The method of any one of the preceding claims, wherein the ionizable lipid is a compound of Formula (IL-IB):

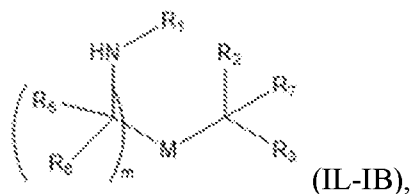

or its N-oxide, or a salt or isomer thereof, in which all variables are as defined herein. In some embodiments, m is selected from 5, 6, 7, 8, and 9; R_4 is hydrogen, unsubstituted C_{1-3} alkyl, or $-(CH_2)_nQ$, in which Q is $-OH$, $-NHC(S)N(R)_2$, $-NHC(O)N(R)_2$, $-N(R)C(O)R$, $-N(R)S(O)_2R$, $-N(R)R_8$, $-NHC(=NR_9)N(R)_2$, $-NHC(=CHR_9)N(R)_2$, $-OC(O)N(R)_2$, $-N(R)C(O)OR$, heteroaryl or heterocycloalkyl; M and M' are independently selected from $-C(O)O-$, $-OC(O)-$, $-OC(O)-M'-C(O)O-$, $-C(O)N(R')$, $-P(O)(OR')O-$, $-S-S-$, an aryl group, and a heteroaryl group; and R_2 and R_3 are independently selected from the group consisting of H, C_{1-14} alkyl, and C_{2-14} alkenyl.

121. The method of any one of the preceding claims, wherein the ionizable lipid is a compound of Formula (IL-II):

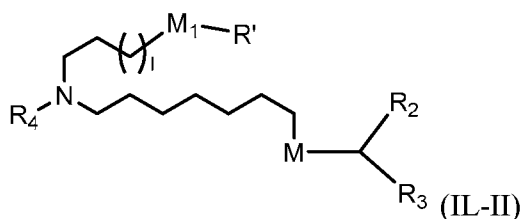

or its N-oxide, or a salt or isomer thereof, wherein l is selected from 1, 2, 3, 4 and 5; M_1 is a bond or M' ; R_4 is hydrogen, unsubstituted C_{1-3} alkyl, or $-(CH_2)_nQ$, in which n is 2, 3, or 4, and Q is $-OH$, $-NHC(S)N(R)_2$, $-NHC(O)N(R)_2$, $-N(R)C(O)R$, $-N(R)S(O)_2R$, $-N(R)R_8$, $-NHC(=NR_9)N(R)_2$, $-NHC(=CHR_9)N(R)_2$, $-OC(O)N(R)_2$, $-N(R)C(O)OR$, heteroaryl or heterocycloalkyl; M and M' are independently selected from $-C(O)O-$, $-OC(O)-$, $-OC(O)-M'-C(O)O-$, $-C(O)N(R')$, $-P(O)(OR')O-$, $-S-S-$, an aryl group, and a heteroaryl group; and R_2 and R_3 are independently selected from the group consisting of H, C_{1-14} alkyl, and C_{2-14} alkenyl.

122. The method of any one of the preceding claims, wherein the ionizable lipid is a compound of Formula (IL-IIa):

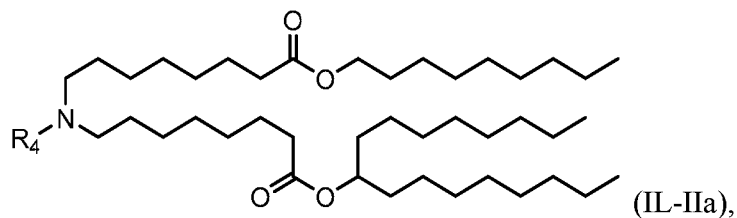

or their N-oxides, or salts or isomers thereof, wherein R₄ is as described herein.

123. The method of any one of the preceding claims, wherein the ionizable lipid is a compound of Formula (IL-IIb):

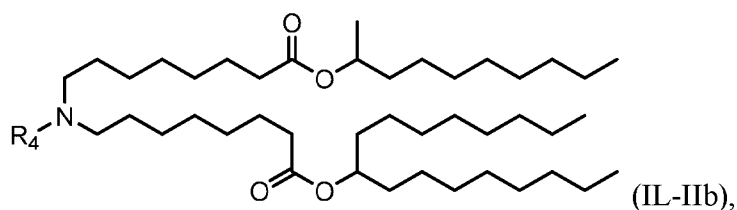

or their N-oxides, or salts or isomers thereof, wherein R₄ is as described herein.

124. The method of any one of the preceding claims, wherein the ionizable lipid is a compound of Formula (IL-IIc) or (IL-IIe):

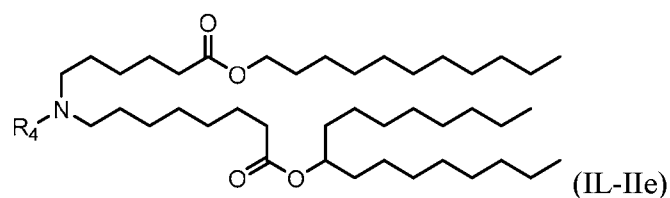
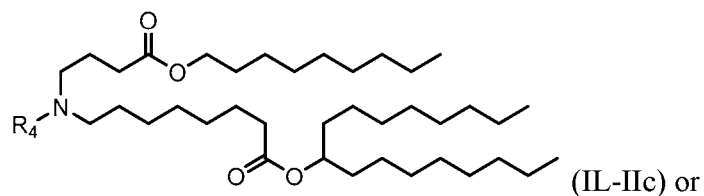

or their N-oxides, or salts or isomers thereof, wherein R₄ is as described herein.

125. The method of any one of the preceding claims, wherein the ionizable lipid is a compound of Formula (IL-IIf):

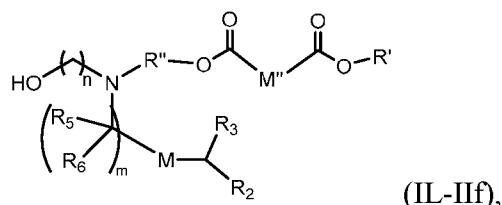

or their N-oxides, or salts or isomers thereof, wherein M is $-\text{C}(\text{O})\text{O}-$ or $-\text{OC}(\text{O})-$, M' is C_{1-6} alkyl or C_{2-6} alkenyl, R_2 and R_3 are independently selected from the group consisting of C_{5-14} alkyl and C_{5-14} alkenyl, and n is selected from 2, 3, and 4.

126. The method of any one of the preceding claims, wherein the ionizable lipid is a compound of Formula (IL-IIId):

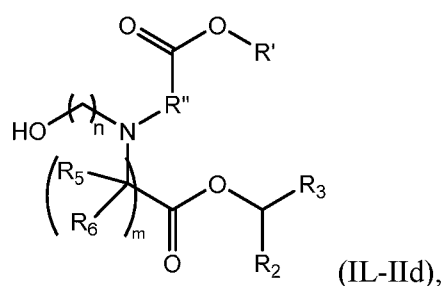

or their N-oxides, or salts or isomers thereof, wherein n is 2, 3, or 4; and m , R' , R'' , and R_2 through R_6 are as described herein. In some embodiments, each of R_2 and R_3 may be independently selected from the group consisting of C_{5-14} alkyl and C_{5-14} alkenyl.

127. The method of any one of the preceding claims, wherein the ionizable lipid is a compound of Formula (IL-IIIg):

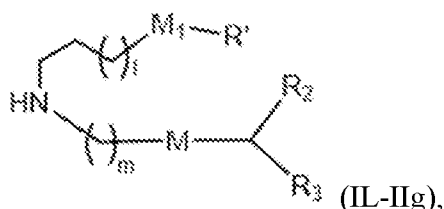

or their N-oxides, or salts or isomers thereof, wherein l is selected from 1, 2, 3, 4, and 5; m is selected from 5, 6, 7, 8, and 9; M_1 is a bond or M' ; M and M' are independently selected from $-\text{C}(\text{O})\text{O}-$, $-\text{OC}(\text{O})-$, $-\text{OC}(\text{O})-\text{M}'-\text{C}(\text{O})\text{O}-$, $-\text{C}(\text{O})\text{N}(\text{R}')-$, $-\text{P}(\text{O})(\text{OR}')\text{O}-$, $-\text{S}-\text{S}-$, an aryl group, and a heteroaryl group; and R_2 and R_3 are independently selected from the group consisting of H, C_{1-14} alkyl, and C_{2-14} alkenyl.

128. The method of any one of the preceding claims, wherein the ionizable lipid is

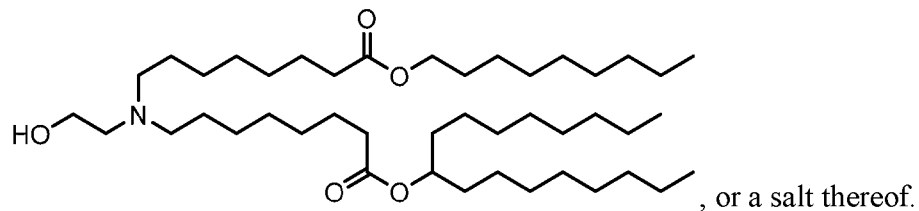

129. The method of any one of the preceding claims, wherein the ionizable lipid is

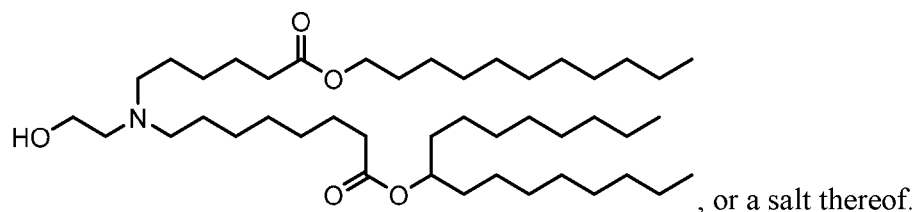

130. The method of any one of the preceding claims, wherein the ionizable lipid is

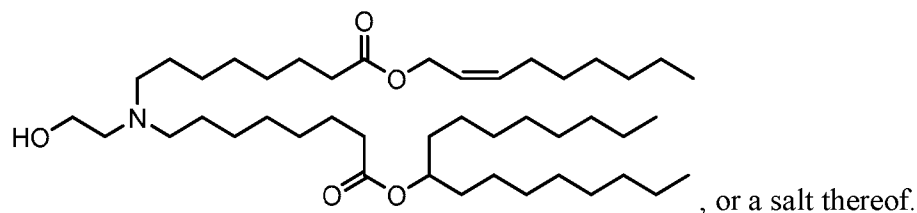

131. The method of any one of the preceding claims, wherein the ionizable lipid is

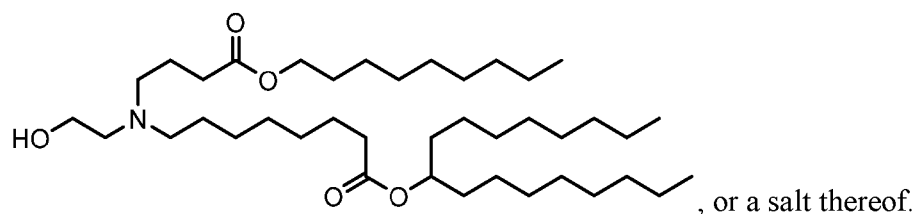

132. The method of any one of the preceding claims, wherein the ionizable lipid is

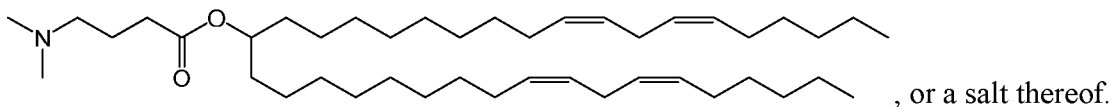

133. The method of any one of the preceding claims, wherein the ionizable lipid is a compound of formula (IL-III):

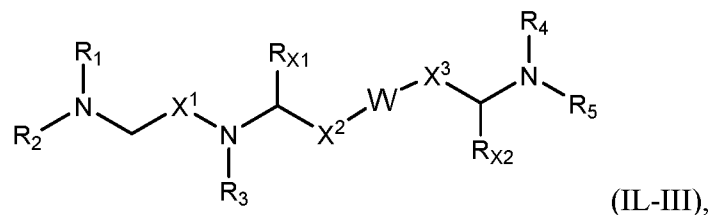

or salts or isomers thereof, wherein,

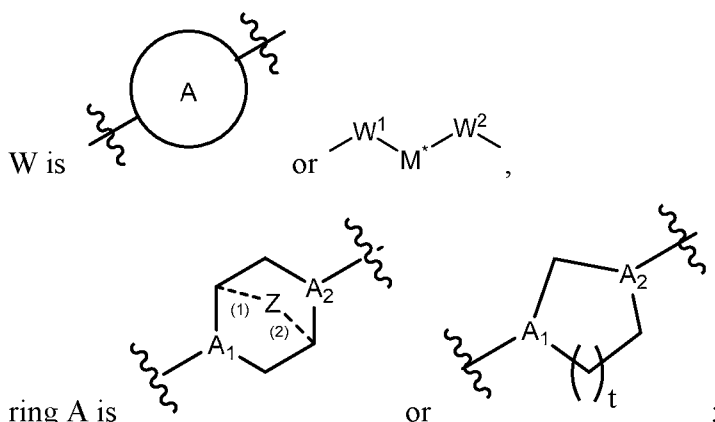

R₁, R₂, R₃, R₄, and R₅ are independently selected from the group consisting of C₅₋₂₀ alkyl, C₅₋₂₀ alkenyl, -R''MR', -R''YR'', -YR'', and -R''OR'';

R_{X1} and R_{X2} are each independently H or C₁₋₃ alkyl;

each M is independently selected from the group consisting of -C(O)O-, -OC(O)-, -OC(O)O-, -C(O)N(R')-, -N(R')C(O)-, -C(O)-, -C(S)-, -C(S)S-, -SC(S)-, -CH(OH)-, -P(O)(OR')O-, -S(O)₂-, -C(O)S-, -SC(O)-, an aryl group, and a heteroaryl group;

M* is C₁₋₆ alkyl,

W¹ and W² are each independently selected from the group consisting of -O- and -N(R₆)-;

each R₆ is independently selected from the group consisting of H and C₁₋₅ alkyl;

X¹, X², and X³ are independently selected from the group consisting of a bond, -CH₂-, -(CH₂)₂-, -CHR-, -CHY-, -C(O)-, -C(O)O-, -OC(O)-, -(CH₂)_n-C(O)-, -C(O)-(CH₂)_n-,

$-(\text{CH}_2)_n\text{-C(O)O-}$, $-\text{OC(O)-}(\text{CH}_2)_n-$, $-(\text{CH}_2)_n\text{-OC(O)-}$, $-\text{C(O)O-}(\text{CH}_2)_n-$, $-\text{CH(OH)-}$, $-\text{C(S)-}$, and $-\text{CH(SH)-}$;

each Y is independently a C₃₋₆ carbocycle;

each R* is independently selected from the group consisting of C₁₋₁₂ alkyl and C₂₋₁₂ alkenyl;

each R is independently selected from the group consisting of C₁₋₃ alkyl and a C₃₋₆ carbocycle;

each R' is independently selected from the group consisting of C₁₋₁₂ alkyl, C₂₋₁₂ alkenyl, and H;

each R'' is independently selected from the group consisting of C₃₋₁₂ alkyl, C₃₋₁₂ alkenyl and $-\text{R}^*\text{MR}'$; and

n is an integer from 1-6;

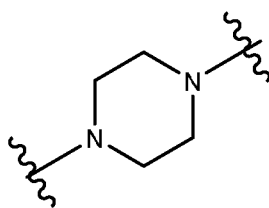

wherein when ring A is , then

i) at least one of X¹, X², and X³ is not $-\text{CH}_2-$; and/or

ii) at least one of R₁, R₂, R₃, R₄, and R₅ is $-\text{R}''\text{MR}'$.

134. The method of any one of the preceding claims, wherein the ionizable lipid is a compound of any of formulae (IL-IIIa1)-(IL-IIIa8):

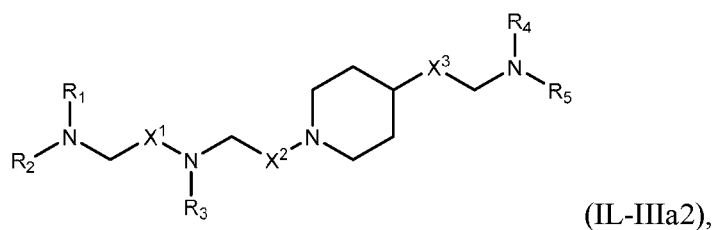
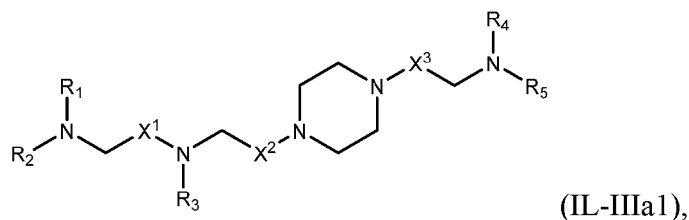

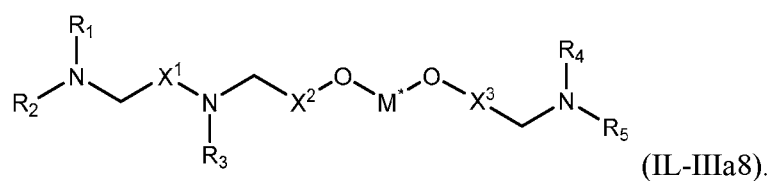
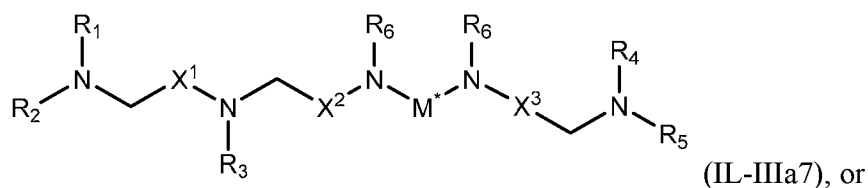
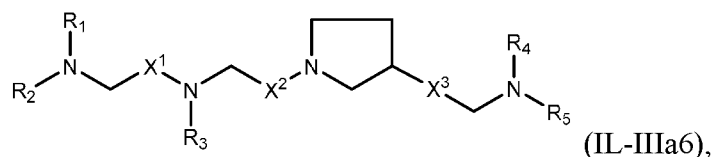
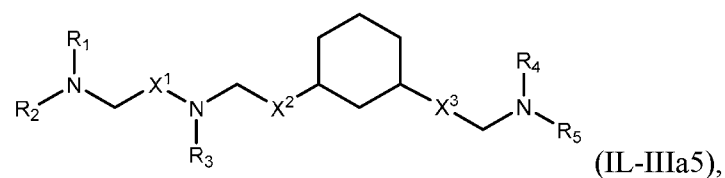
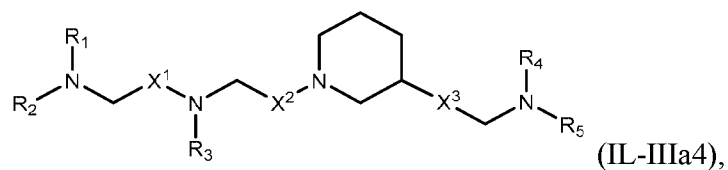
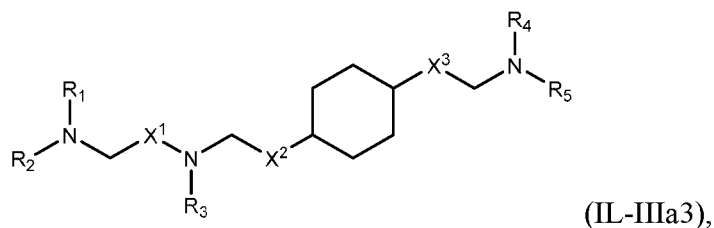

135. The method of any one of the preceding claims, wherein the ionizable lipid is

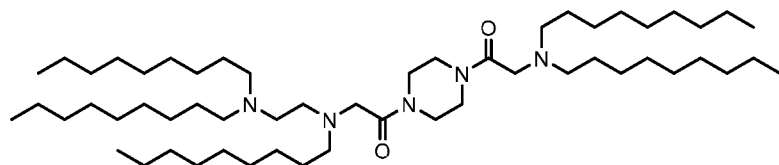

, or a salt thereof.

136. The method of any one of the preceding claims, wherein the ionizable lipid is selected from the group consisting of 3-(didodecylamino)-N1,N1,4-tridodecyl-1-piperazineethanamine (KL10), N1-[2-(didodecylamino)ethyl]-N1,N4,N4-tridodecyl-1,4-piperazinediethanamine

(KL22), 14,25-ditridecyl-15,18,21,24-tetraaza-octatriacontane (KL25),
 1,2-dilinoleyloxy-N,N-dimethylaminopropane (DLin-DMA),
 2,2-dilinoleyloxy-4-dimethylaminomethyl-[1,3]-dioxolane (DLin-K-DMA),
 heptatriaconta-6,9,28,31-tetraen-19-yl 4-(dimethylamino)butanoate (DLin-MC3-DMA),
 2,2-dilinoleyloxy-4-(2-dimethylaminoethyl)-[1,3]-dioxolane (DLin-KC2-DMA),
 1,2-dioleyloxy-N,N-dimethylaminopropane (DODMA),
 2-({8-[(3 β)-cholest-5-en-3-yloxy]octyl}oxy)-N,N-dimethyl-3-[(9Z,12Z)-octadeca-9,12-dien-1-yl
 oxy]propan-1-amine (Octyl-CLinDMA),
 (2R)-2-({8-[(3 β)-cholest-5-en-3-yloxy]octyl}oxy)-N,N-dimethyl-3-[(9Z,12Z)-octadeca-9,12-die
 n-1-yloxy]propan-1-amine (Octyl-CLinDMA (2R)), and
 (2S)-2-({8-[(3 β)-cholest-5-en-3-yloxy]octyl}oxy)-N,N-dimethyl-3-[(9Z,12Z)-octadeca-9,12-dien
 -1-yloxy]propan-1-amine (Octyl-CLinDMA (2S)).

137. The method of any one of the preceding claims, wherein the LNP formulation and/or LNP composition has a N:P ratio from about 1.1:1 to about 30:1.

138. The method of any one of the preceding claims, wherein the LNP formulation and/or LNP composition has a N:P ratio from about 2:1 to about 20:1.

139. The method of any one of the preceding claims, wherein the LNP formulation and/or LNP composition has a N:P ratio from about 2:1 to about 10:1 or from about 2:1 to about 5:1.

140. The method of any one of the preceding claims, wherein the LNP formulation and/or LNP composition has an average LNP diameter of about 40 nm to about 150 nm.

141. The method of any one of the preceding claims, wherein the LNP formulation and/or LNP composition has a polydispersity index from about 0.01 to about 0.25.

142. The method of any one of the preceding claims, wherein the LNP formulation and/or LNP composition has an encapsulation efficiency of at least about 50%, at least about 60%, at least about 70%, at least about 80%, or at least about 90%.

143. The method of any one of the preceding claims, wherein the average LNP diameter of the LNP formulation is about 99% or less, about 98% or less, about 97% or less, about 96% or less, about 95% or less, about 90% or less, about 85% or less, about 80% or less, about 75% or less, about 70% or less, about 65% or less, about 60% or less, about 55% or less, about 50% or less, about 40% or less, about 30% or less, about 20% or less, or about 10% or less as compared to the LNP formulation produced by a comparable method.

144. The method of any one of the preceding claims, wherein the encapsulation efficiency of the LNP formulation is higher than the encapsulation efficiency of the LNP formulation produced by a comparable method by about 5% or higher, about 10% or more, about 15% or more, about 20% or more, about 30% or more, about 40% or more, about 50% or more, about 60% or more, about 70% or more, about 80% or more, about 90% or more, about 1 folds or more, about 2 folds or more, about 3 folds or more, about 4 folds or more, about 5 folds or more, about 10 folds or more, about 20 folds or more, about 30 folds or more, about 40 folds or more, about 50 folds or more, about 100 folds or more, about 200 folds or more, about 300 folds or more, about 400 folds or more, about 500 folds or more, about 1000 folds or more, about 2000 folds or more, about 3000 folds or more, about 4000 folds or more, about 5000 folds or more, or about 10000 folds or more.

145. The method of any one of the preceding claims, wherein the nucleic acid expression (e.g., the mRNA expression) of the LNP formulation is about 20% or higher, about 25% or higher, about 30% or higher, about 35% or higher, about 40% or higher, about 45% or higher, about 50% or higher, about 55% or higher, about 60% or higher, about 65% or higher, about 70% or higher, about 75% or higher, about 80% or higher, about 85% or higher, about 90% or higher, about 95% or higher, about 96% or higher, about 97% or higher, about 98% or higher, or about 99% or higher.

146. The method of any one of the preceding claims, wherein the nucleic acid expression (e.g., the mRNA expression) of the LNP formulation is higher than the nucleic acid expression (e.g., the mRNA expression) of the LNP formulation produced by a comparable method by about 5%

or higher, about 10% or more, about 15% or more, about 20% or more, about 30% or more, about 40% or more, about 50% or more, about 60% or more, about 70% or more, about 80% or more, about 90% or more, about 1 folds or more, about 2 folds or more, about 3 folds or more, about 4 folds or more, about 5 folds or more, about 10 folds or more, about 20 folds or more, about 30 folds or more, about 40 folds or more, about 50 folds or more, about 100 folds or more, about 200 folds or more, about 300 folds or more, about 400 folds or more, about 500 folds or more, about 1000 folds or more, about 2000 folds or more, about 3000 folds or more, about 4000 folds or more, about 5000 folds or more, or about 10000 folds or more.

147. A method of treating or preventing a disease or disorder, comprising administering a lipid nanoparticle (LNP) formulation to a subject in need thereof according to the method of any one of the preceding claims.

148. A lipid nanoparticle (LNP) formulation and/or lipid nanoparticle (LNP) composition being prepared by the method of any one of the preceding claims.

149. A lipid nanoparticle (LNP) formulation and/or lipid nanoparticle (LNP) composition, prepared by the method of any one of the preceding claims, for treating or preventing a disease or disorder.

150. The aqueous buffer solution and/or the organic solution of any one of the preceding claims.

151. Use of the aqueous buffer solution and/or the organic solution of any one of the preceding claims in the manufacture of a medicament (e.g., a lipid nanoparticle (LNP) formulation and/or lipid nanoparticle (LNP) composition) for treating or preventing a disease or disorder.

152. A kit comprising an aqueous buffer solution according to any one of the preceding claims and an organic solution according to any one of the preceding claims.

153. The kit of claim 152 further comprising a mixing and administering device according to any one of the preceding claims.

1/44

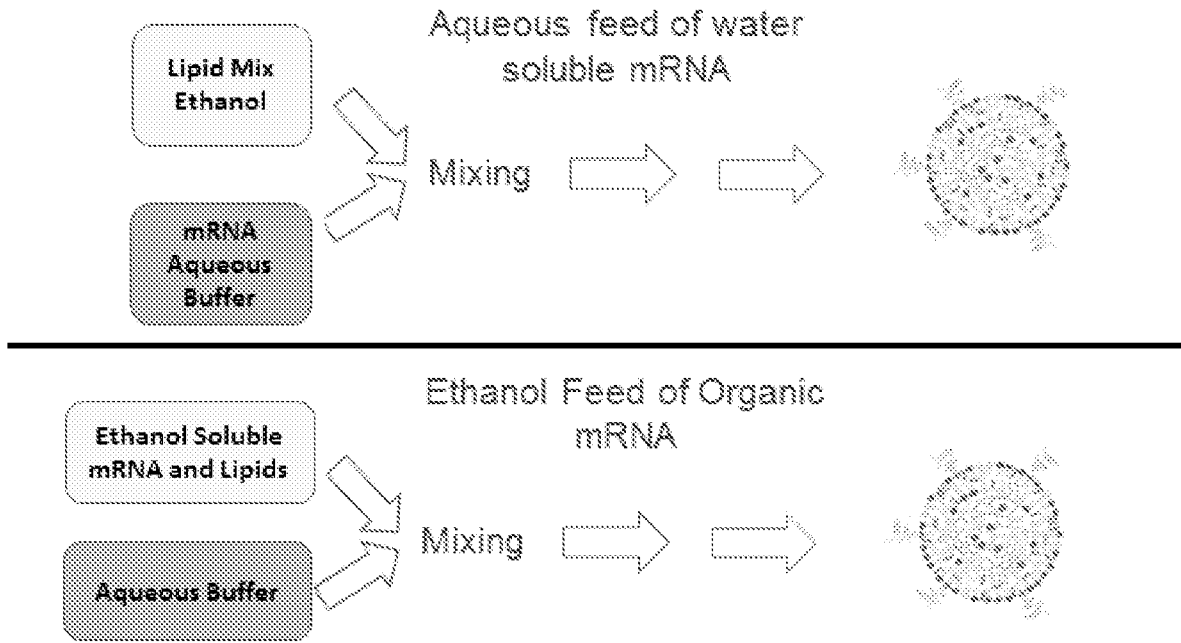

Figure 1

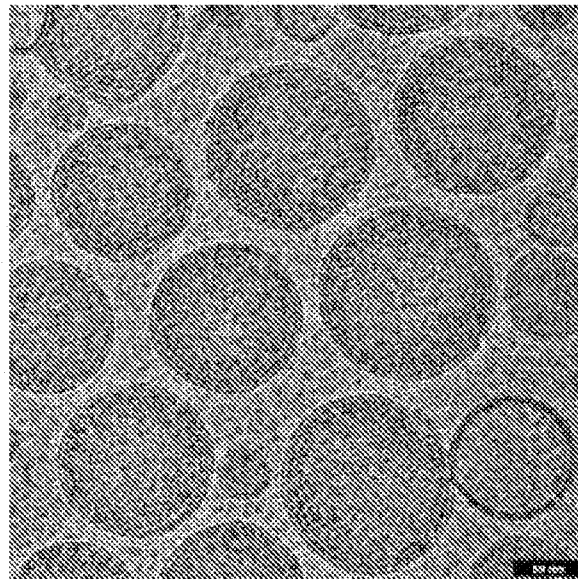

Figure 2

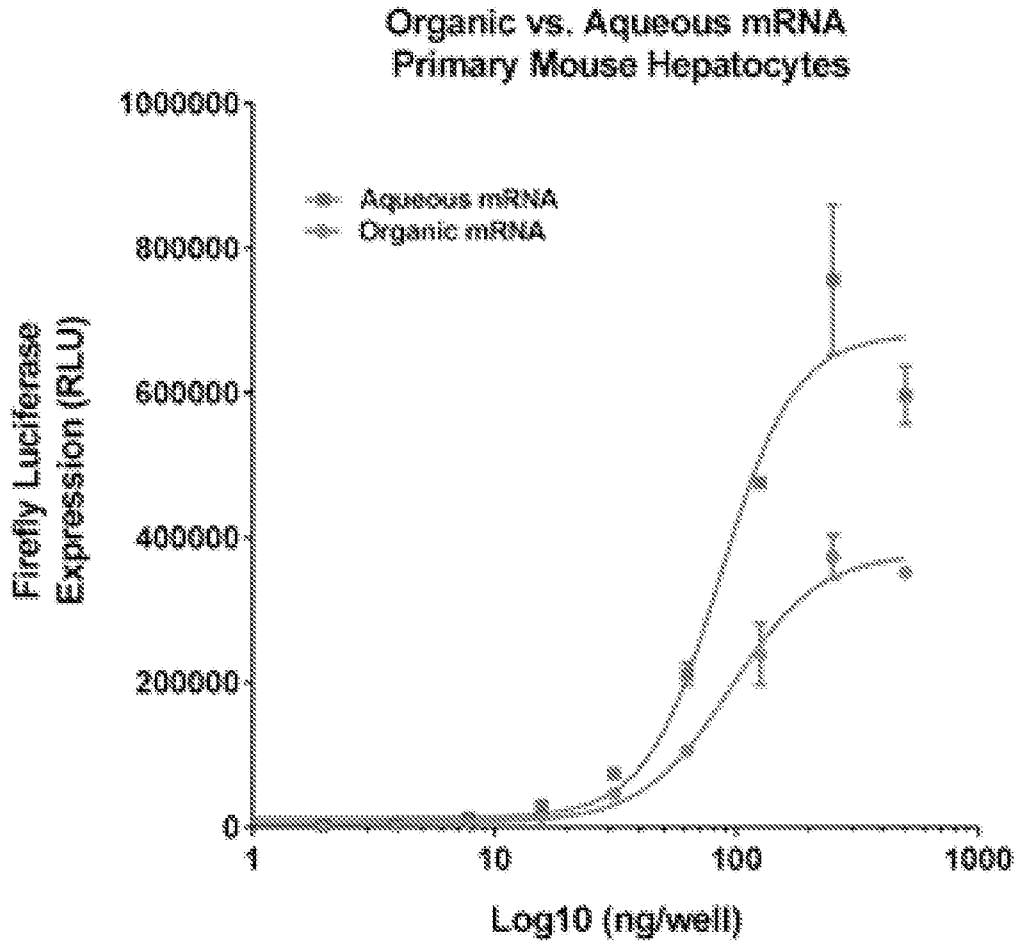

Figure 3

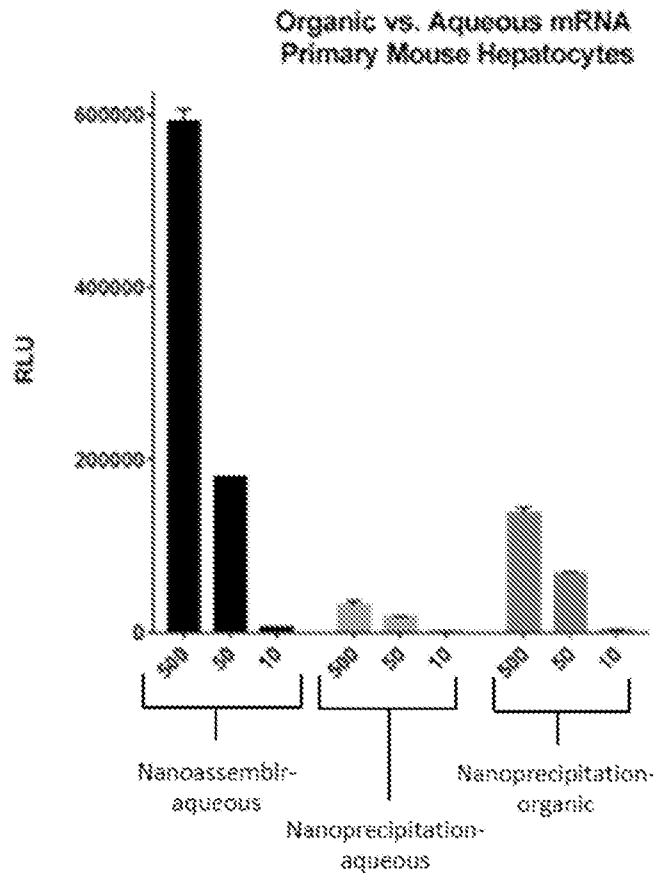

Figure 4

4/44

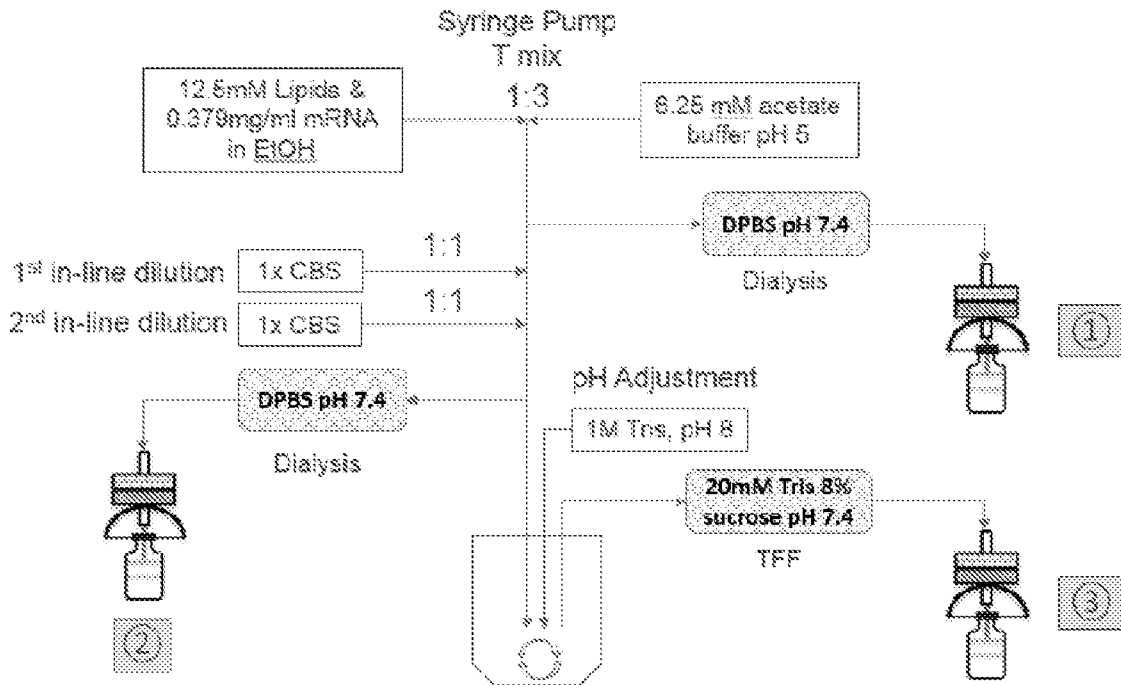

Figure 5

5/44

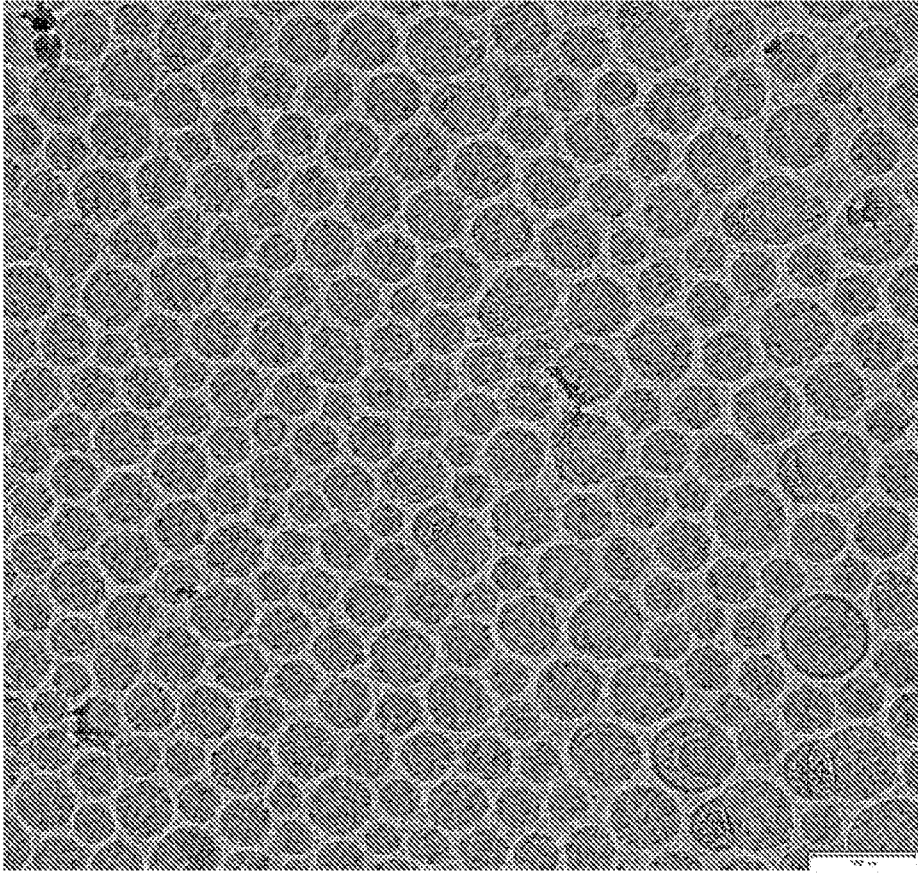

Figure 6

6/44

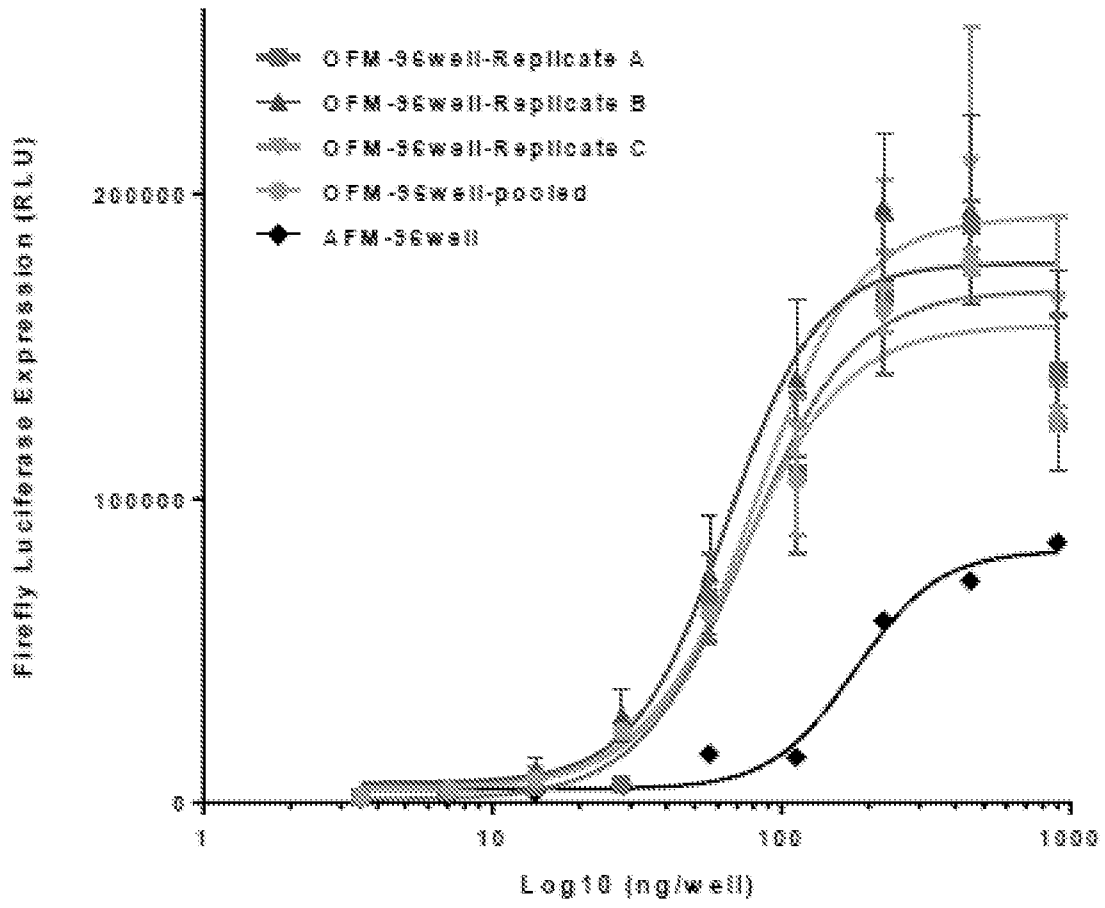

Figure 7

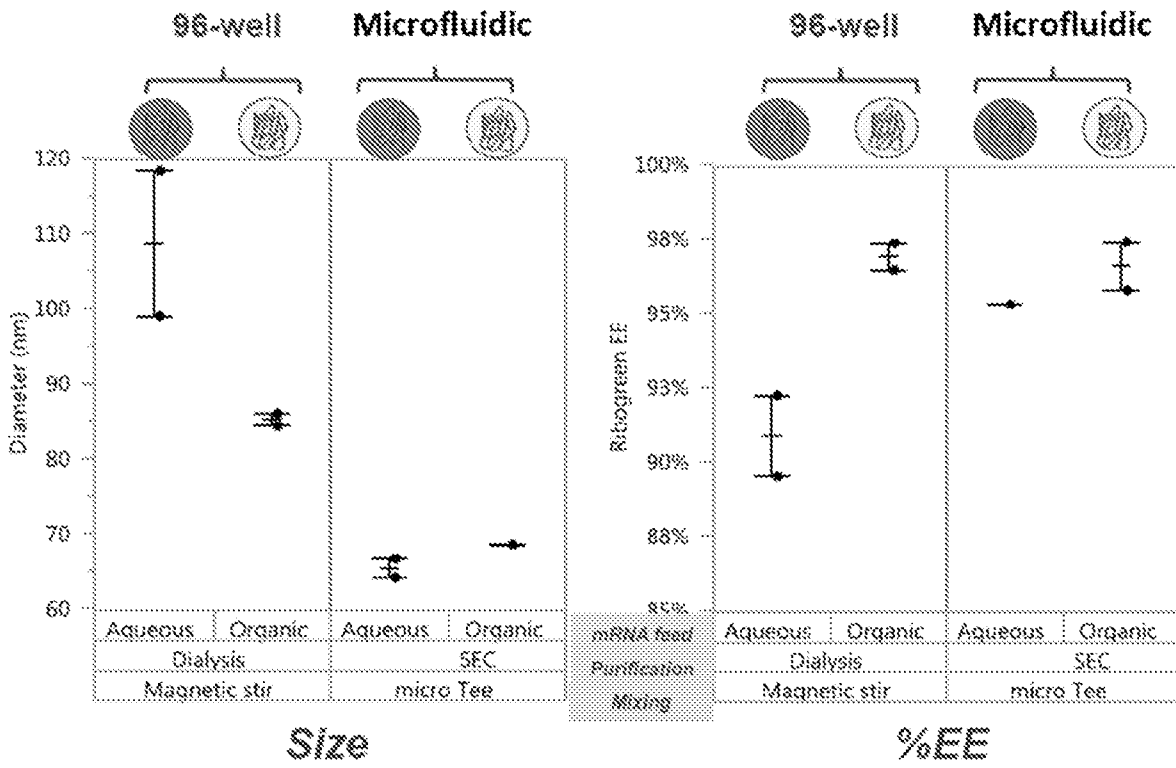

Figure 8

8/44

6 Hr WB
IV administration

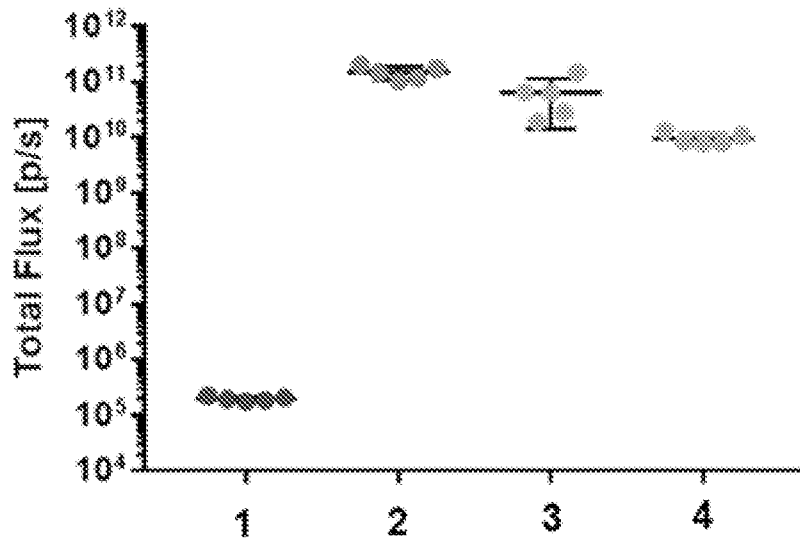

Figure 9

24 Hr WB
IV administration

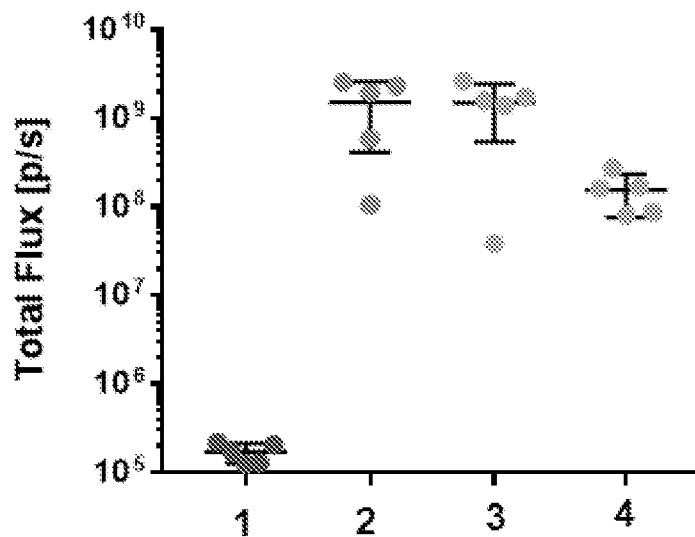

Figure 10

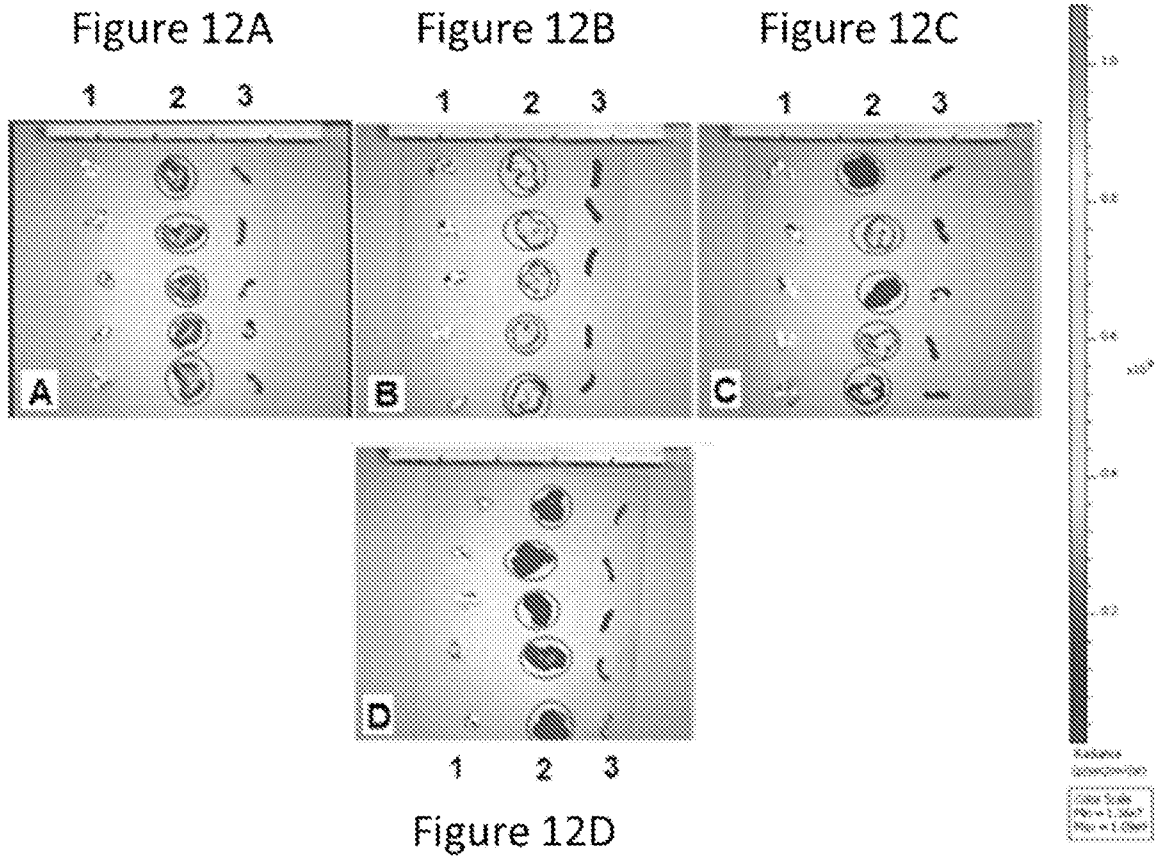

Figure 13A

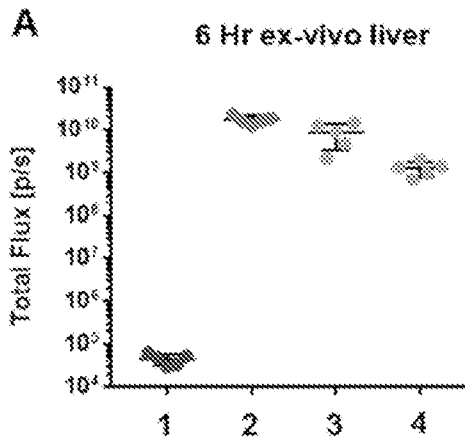
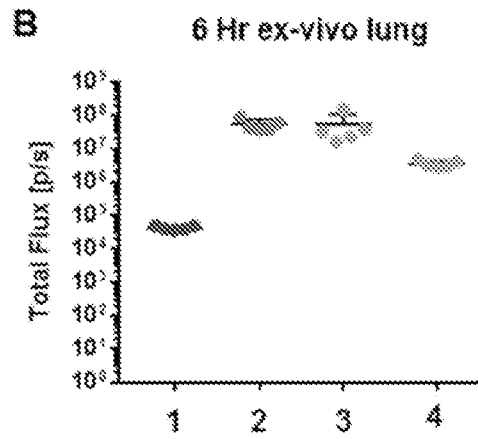

Figure 13B



C 6 Hr ex-vivo spleen

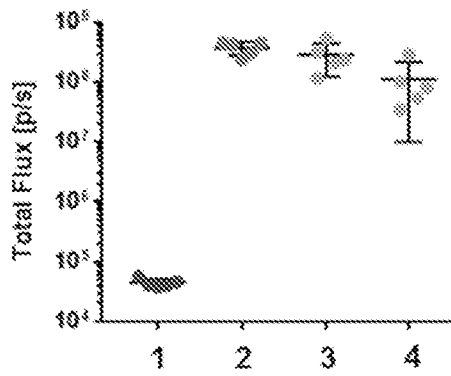

Figure 13C

Figure 14A

Figure 14B

Figure 14C

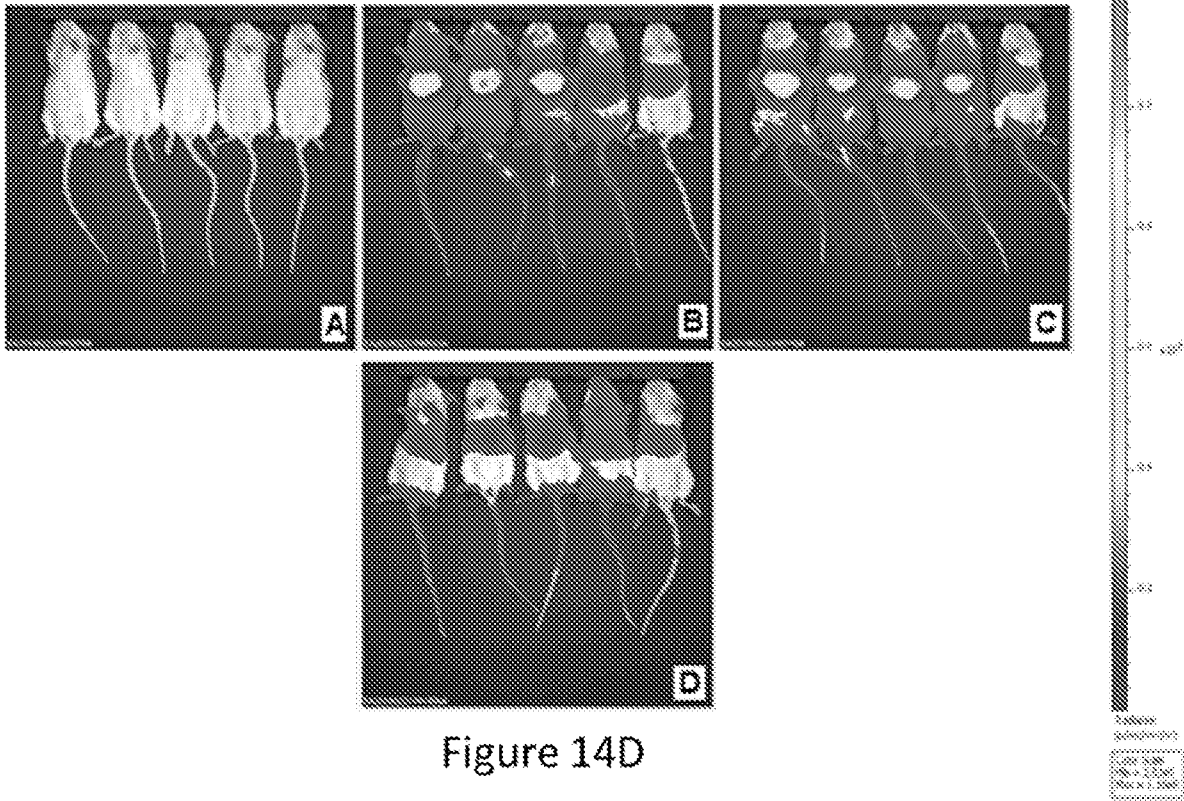

Figure 14D

13/44

6 Hr WB dorsal

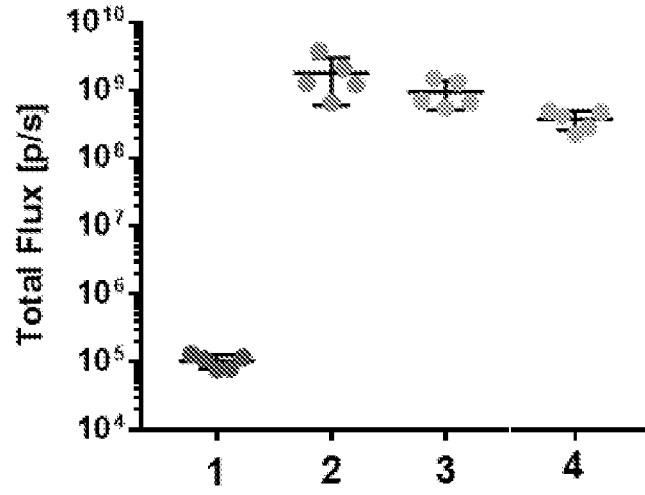

Figure 15

24 Hr WB dorsal

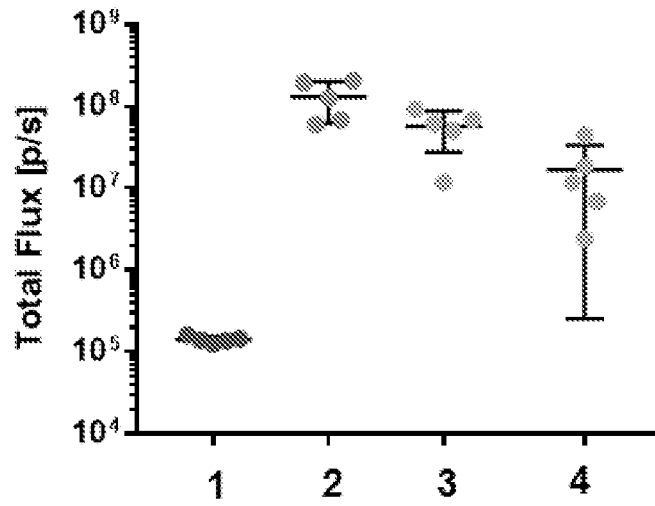

Figure 16

Figure 17A

Figure 17B

Figure 17C

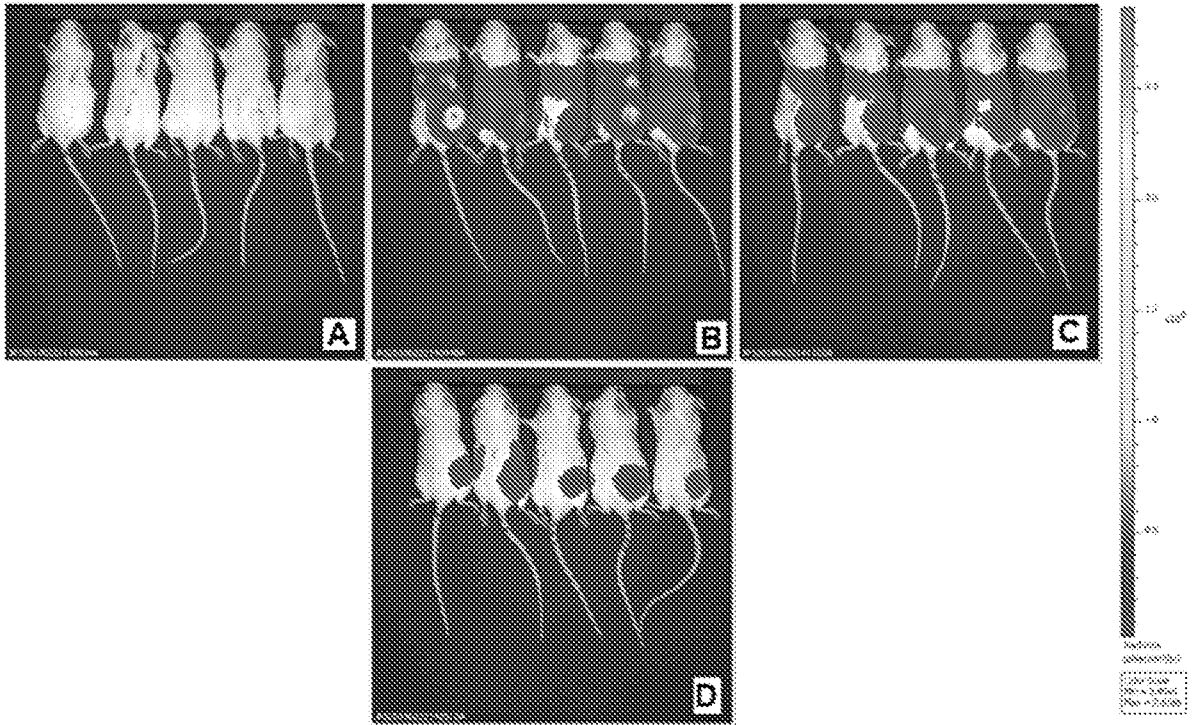

Figure 17D

Figure 18A

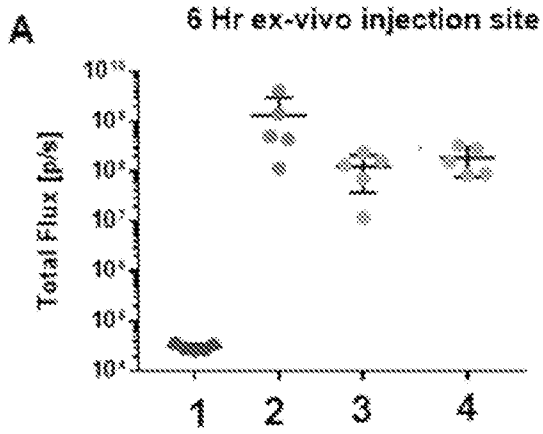
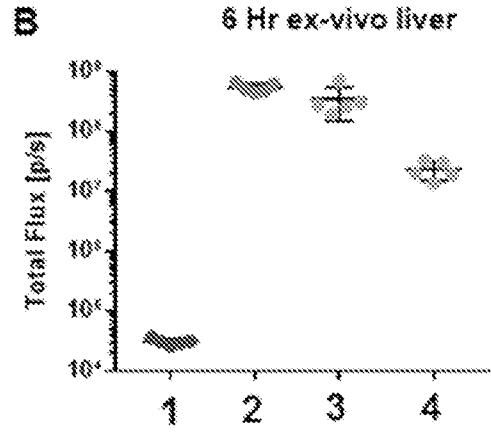

Figure 18B



C 6 Hr ex-vivo lung

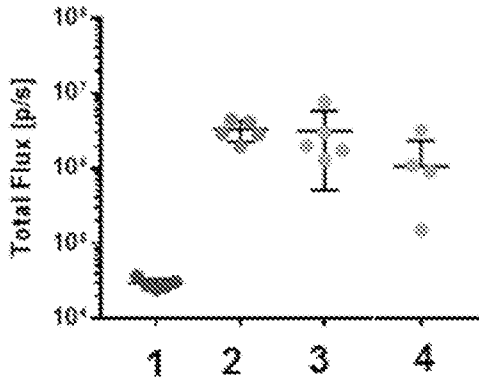

Figure 18C

D 6 Hr ex-vivo spleen

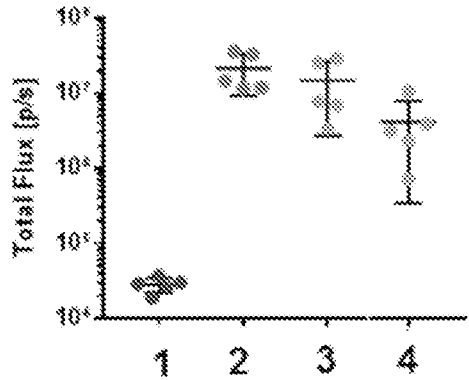

Figure 18D

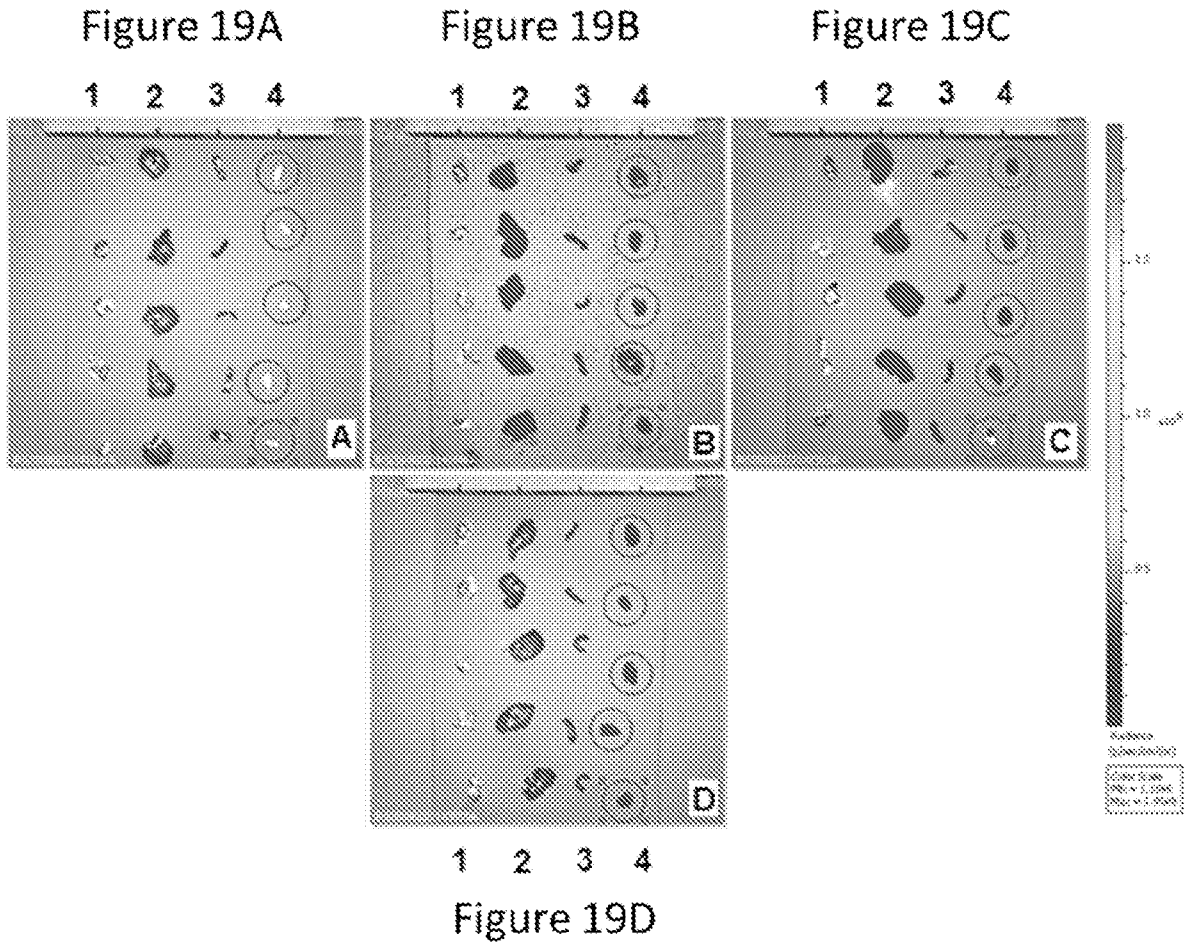

Figure 20A

Figure 20B

Figure 20C

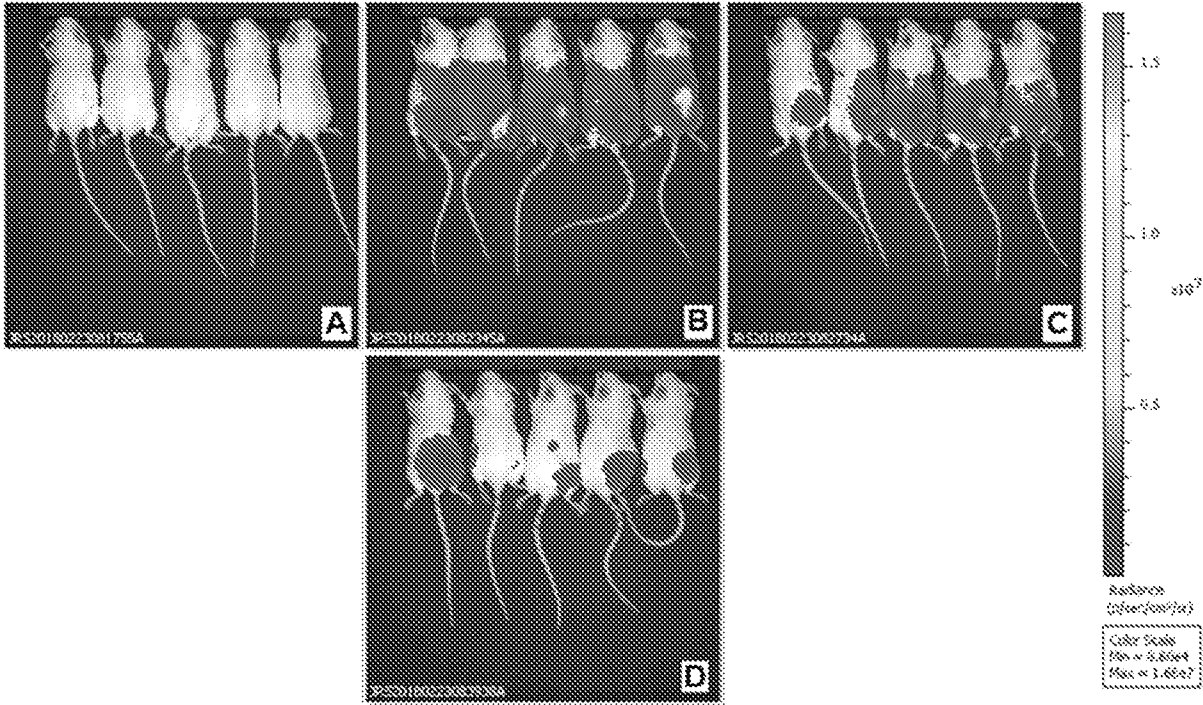

Figure 20D

Figure 21A

A 24 Hr ex-vivo injection site

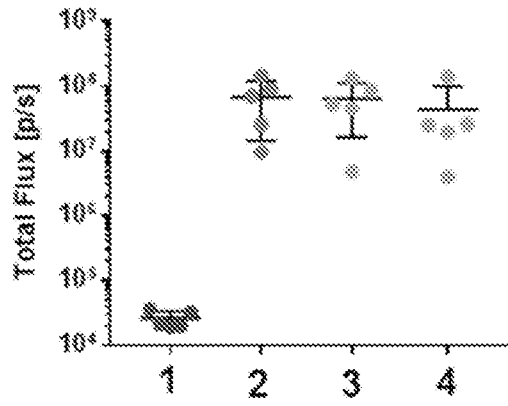
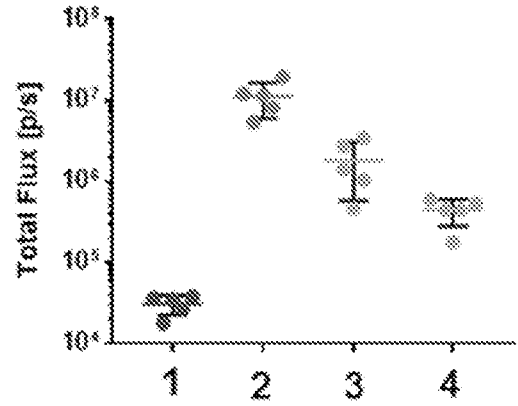

Figure 21B

B 24 Hr ex-vivo liver



C 24 Hr ex-vivo lung

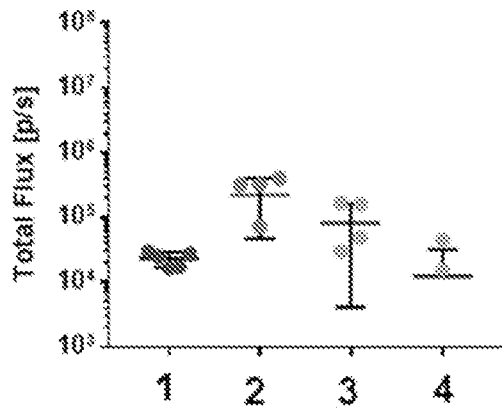

Figure 21C

D 24 Hr ex-vivo spleen

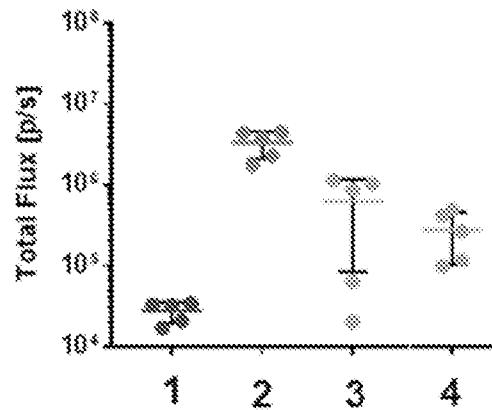
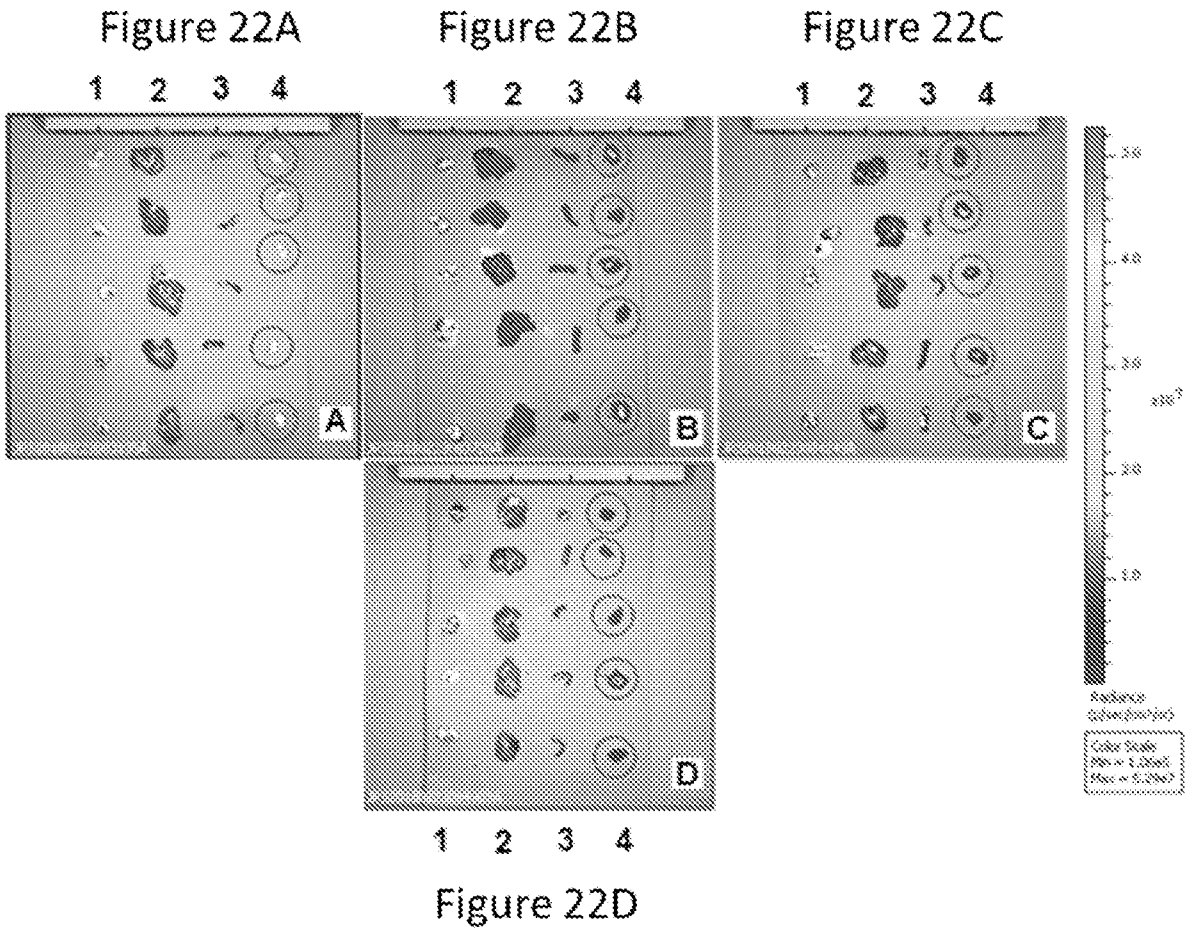

Figure 21D



20/44

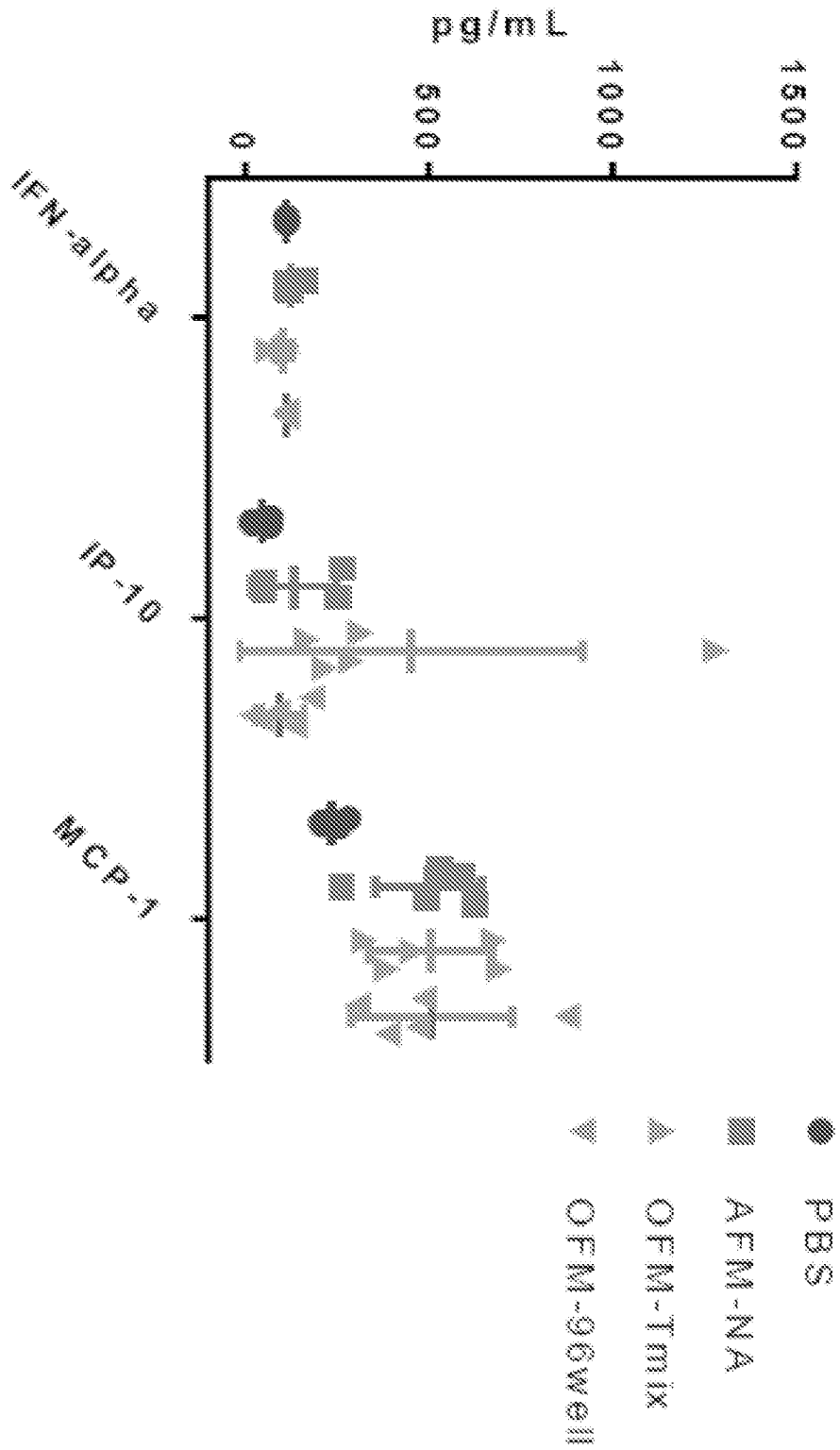

Figure 23

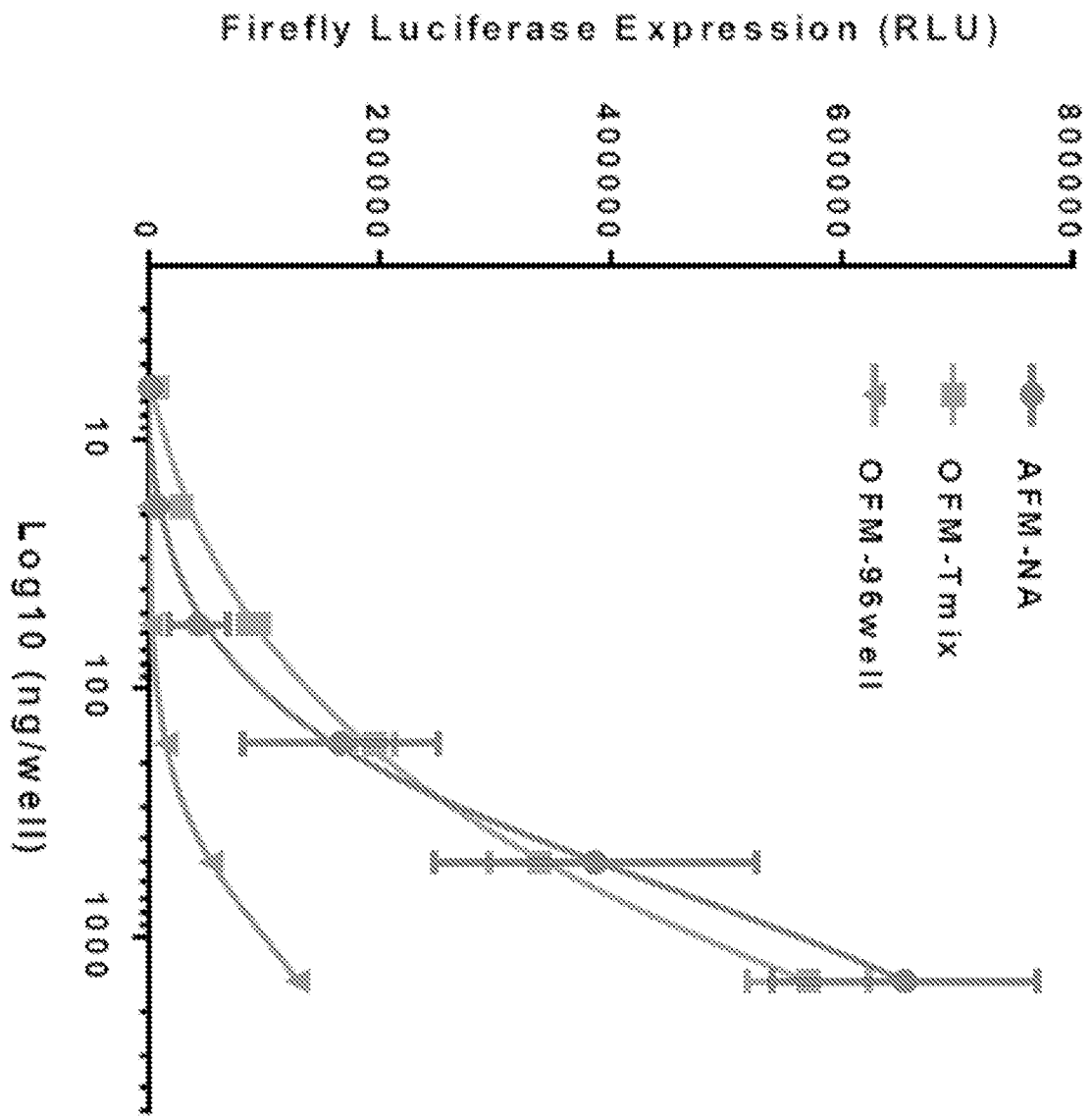

Figure 24

22/44

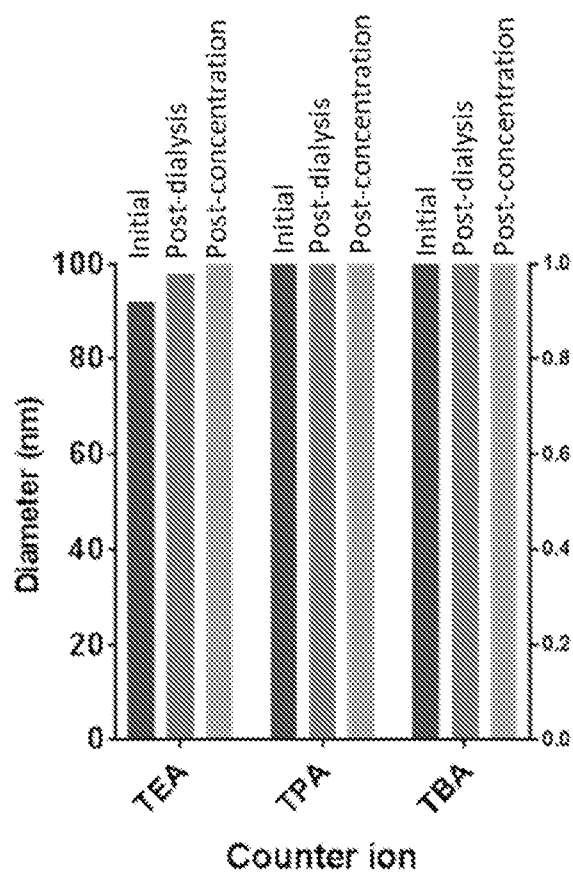

Figure 25

23/44

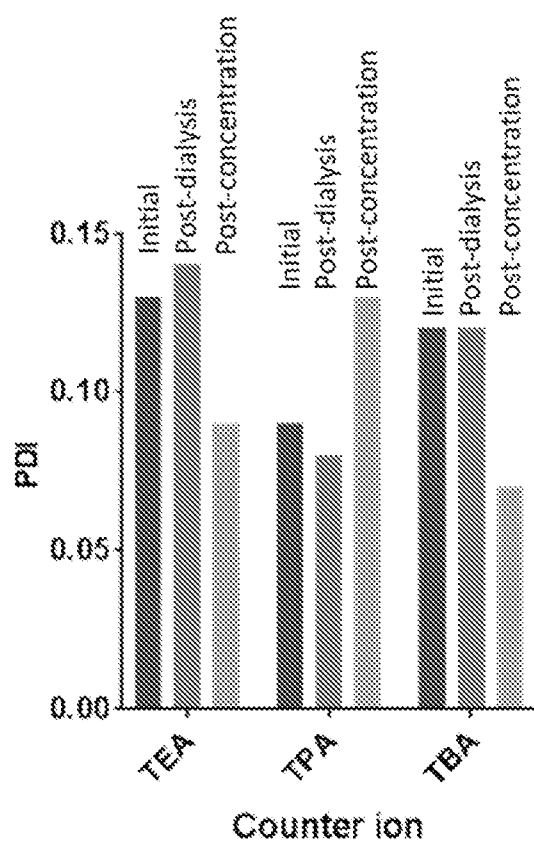

Figure 26

24/44

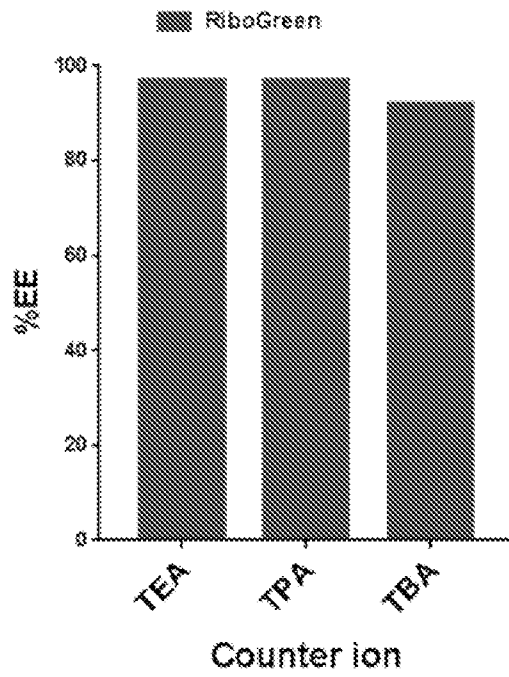

Figure 27

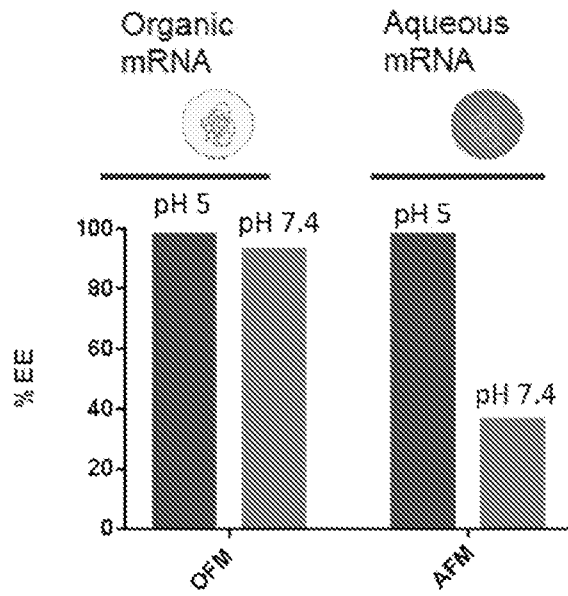

Figure 28

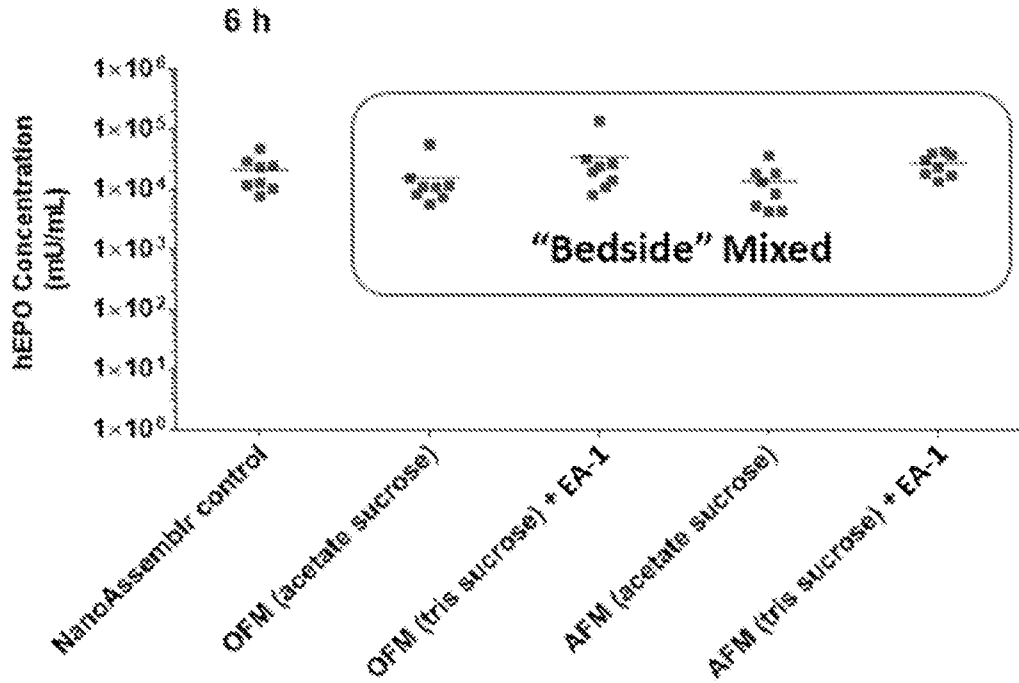

Figure 29

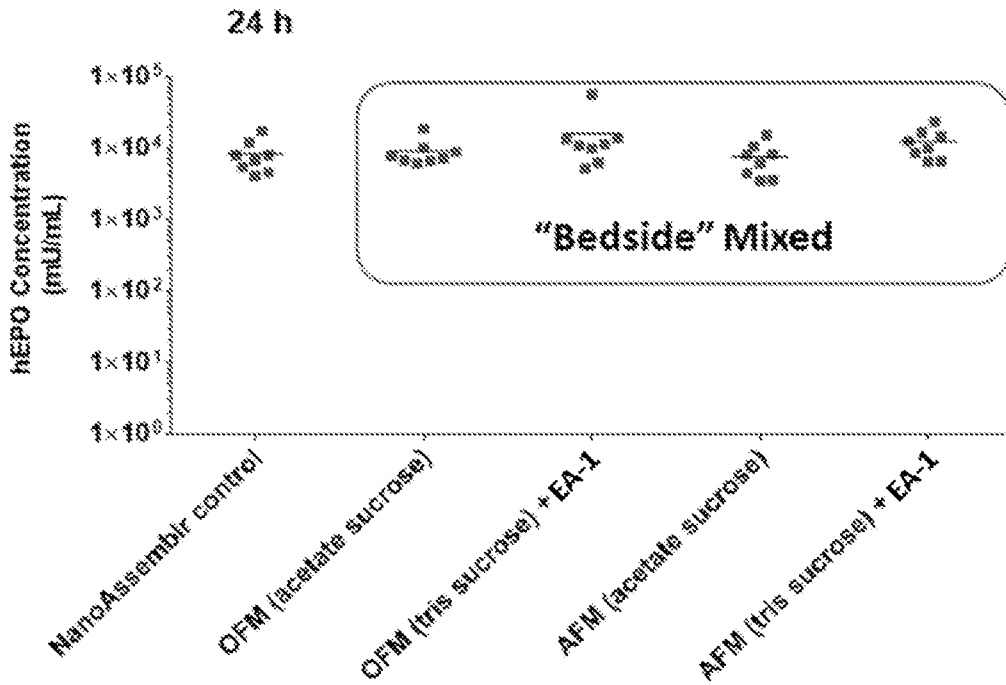

Figure 30

26/44

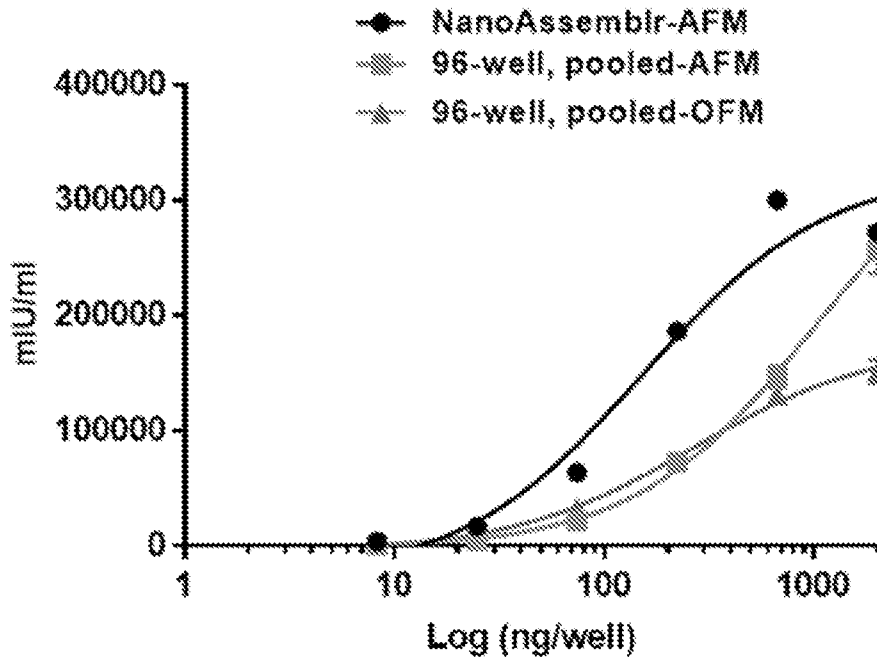

Figure 31

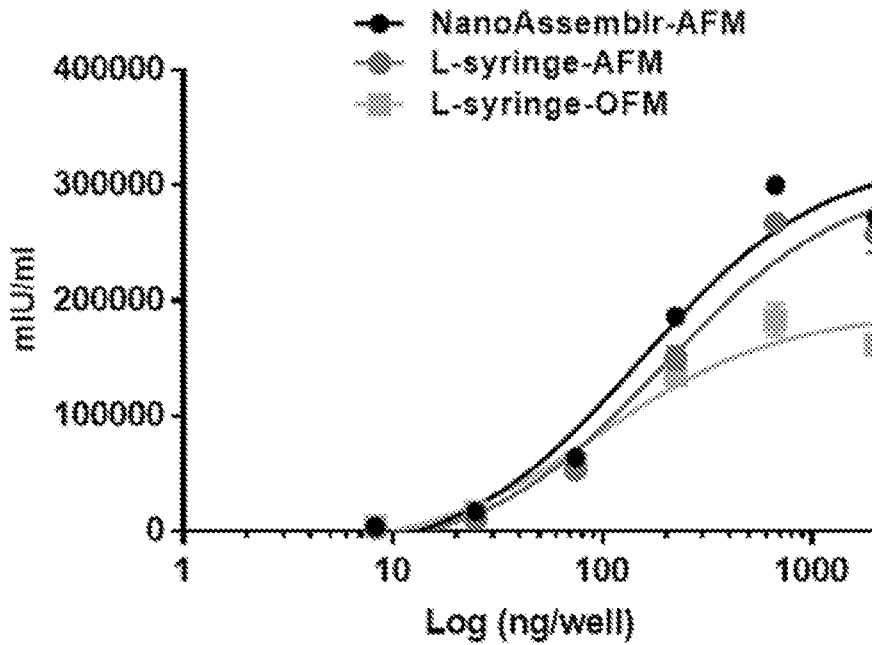

Figure 32

27/44

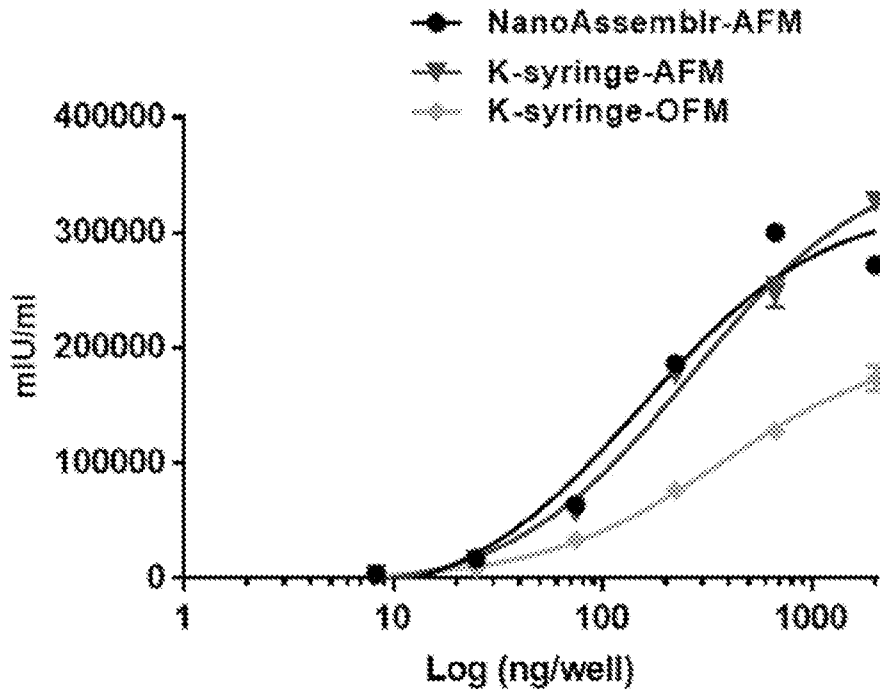

Figure 33

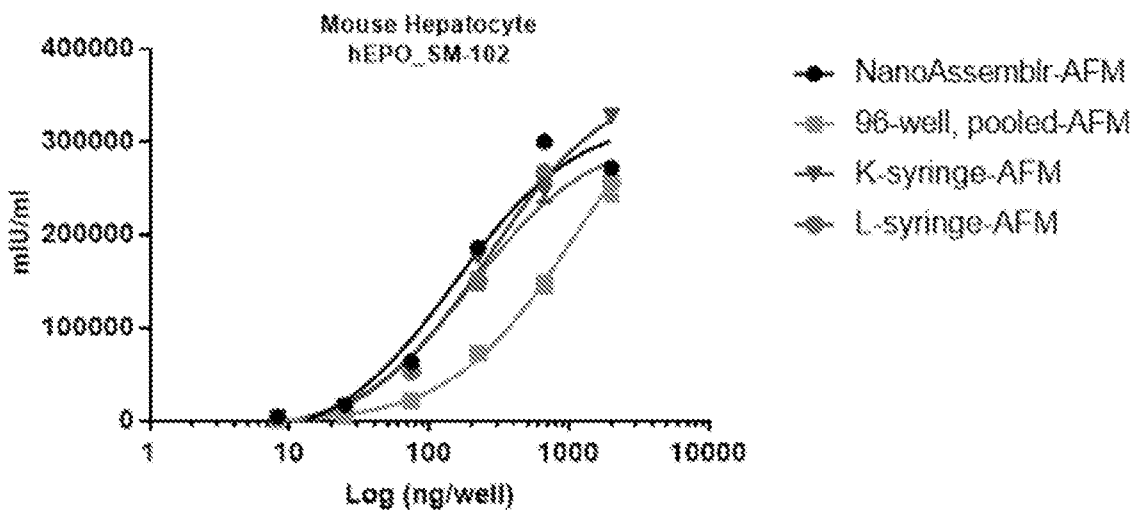

Figure 34

28/44

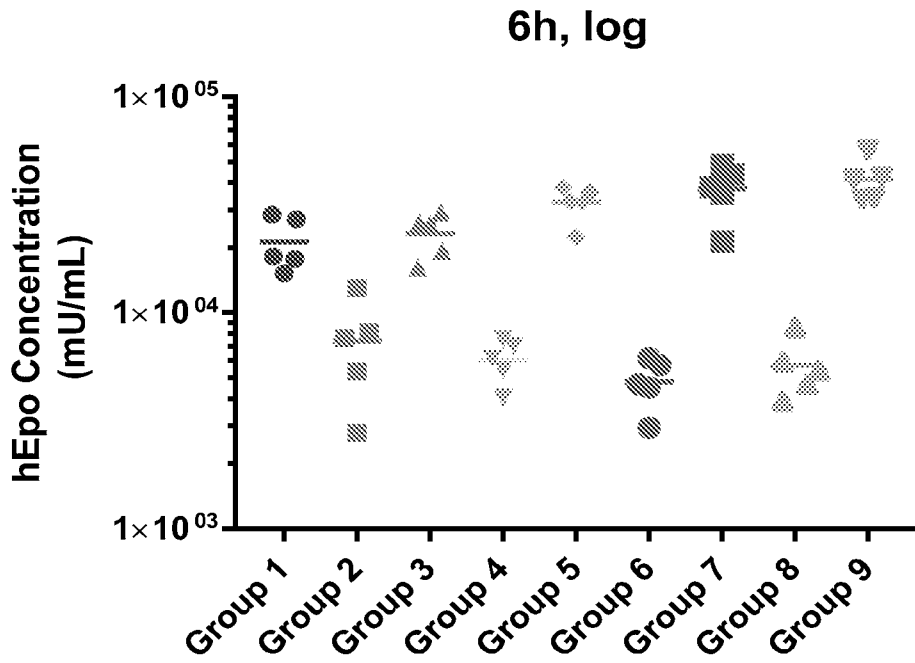

Figure 35

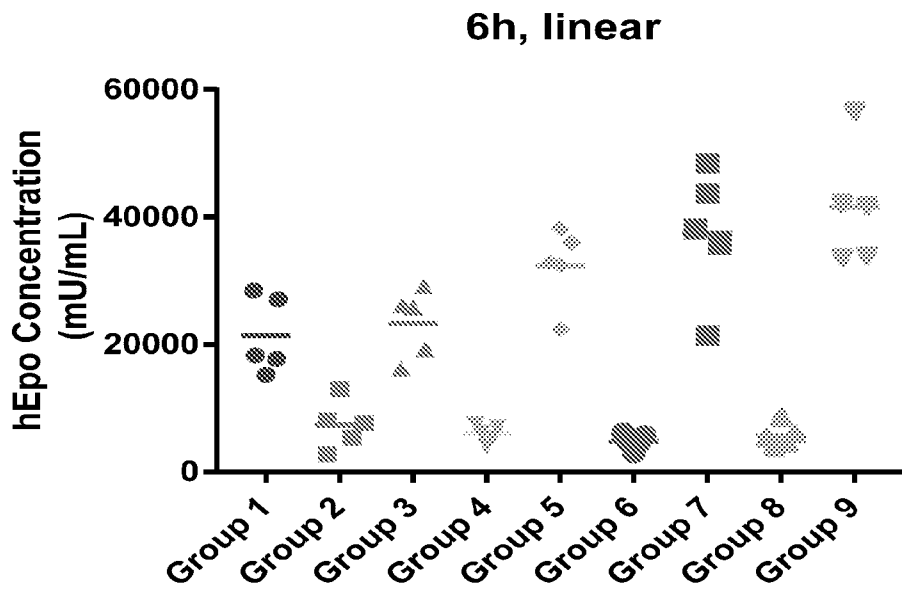

Figure 36

29/44

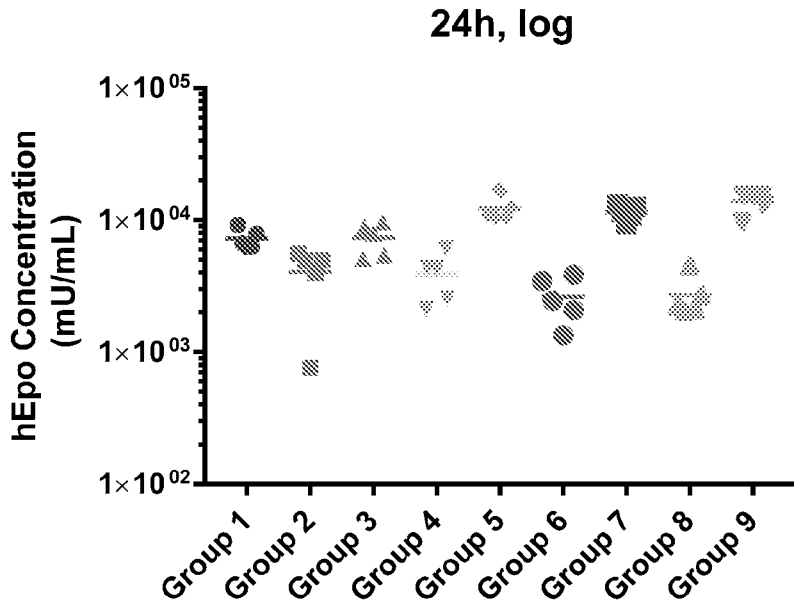

Figure 37

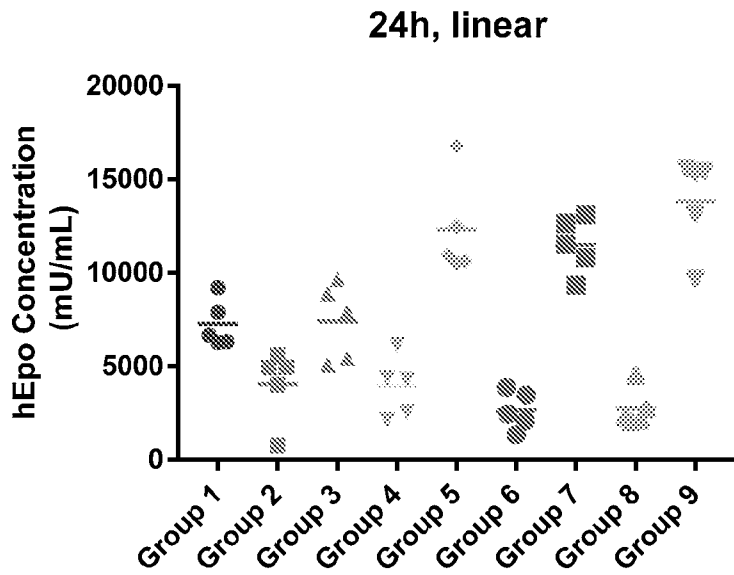

Figure 38

30/44

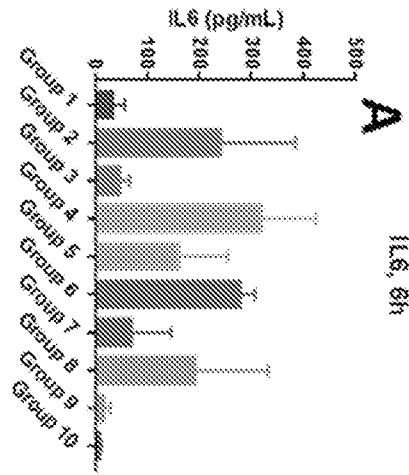

Figure 39A

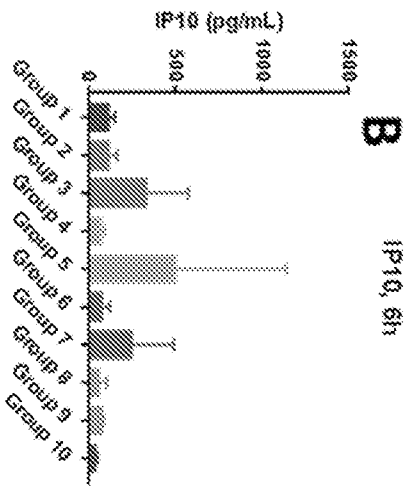

Figure 39B

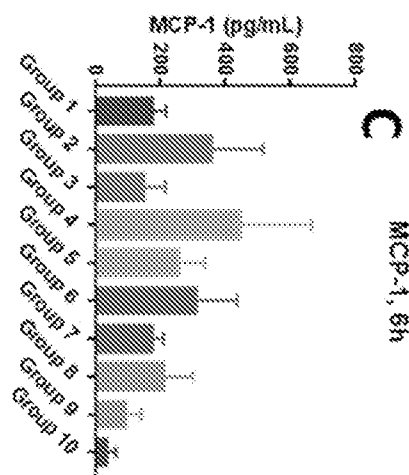

Figure 39C

31/44

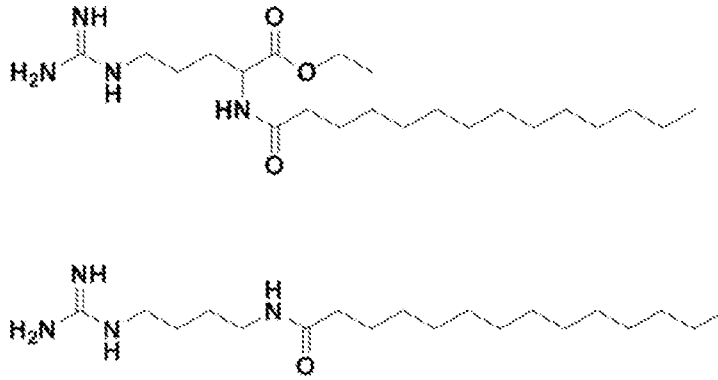

Figure 40

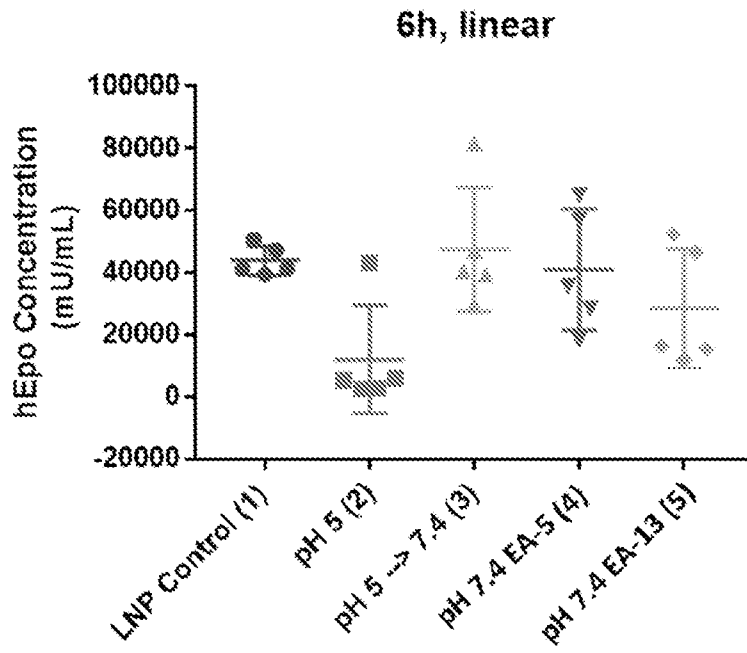

Figure 41

32/44

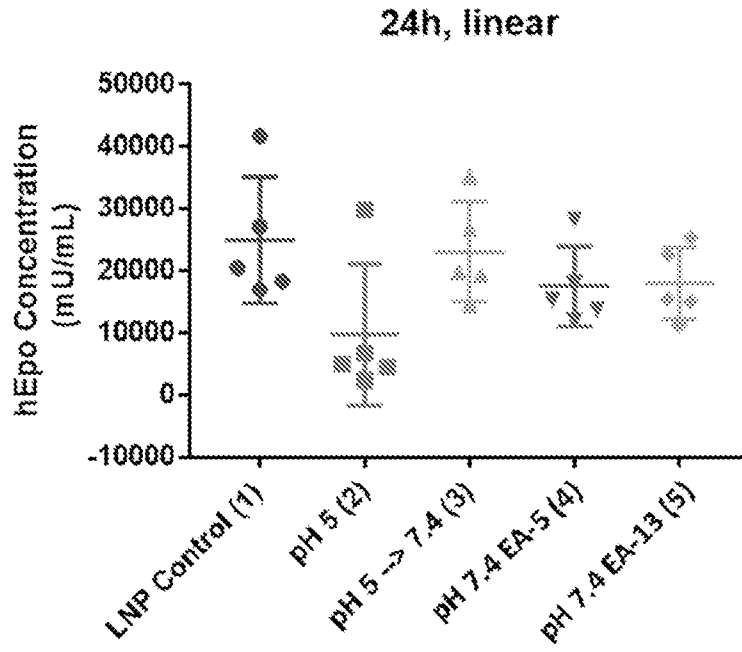

Figure 42

33/44

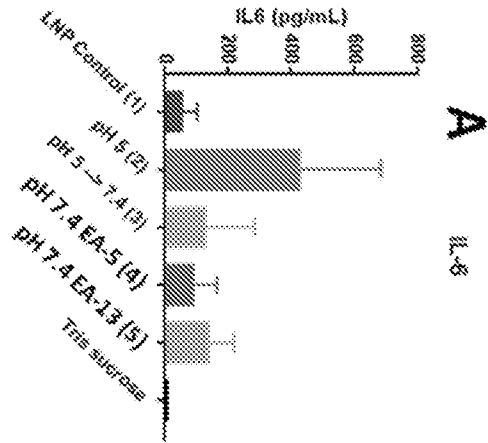

Figure 43A

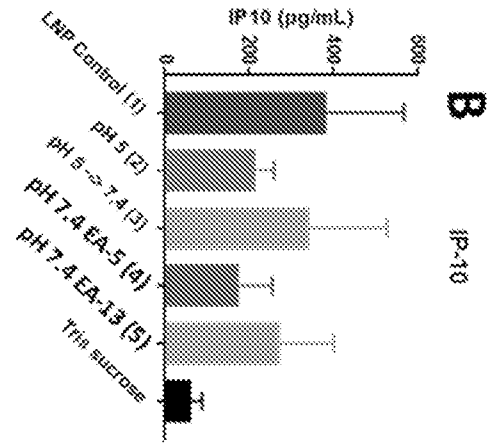

Figure 43B

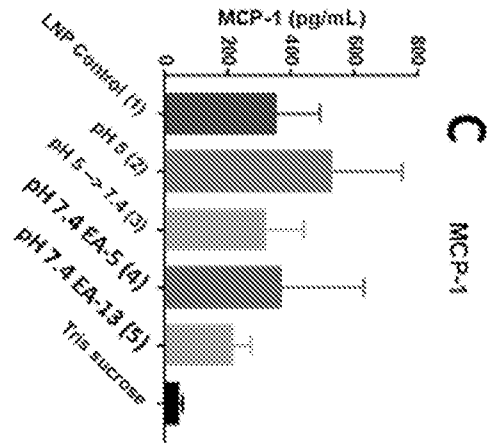

Figure 43C

34/44

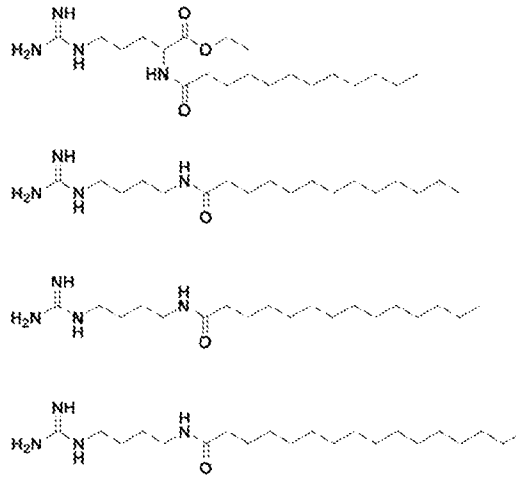

Figure 44

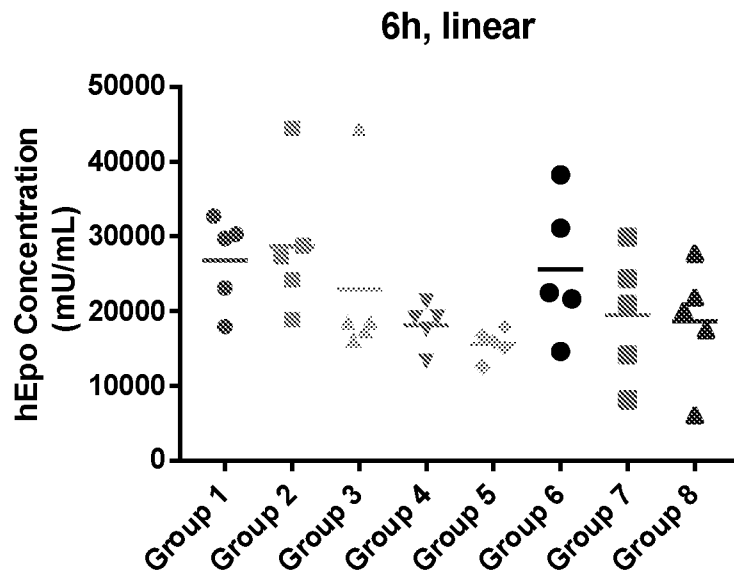

Figure 45

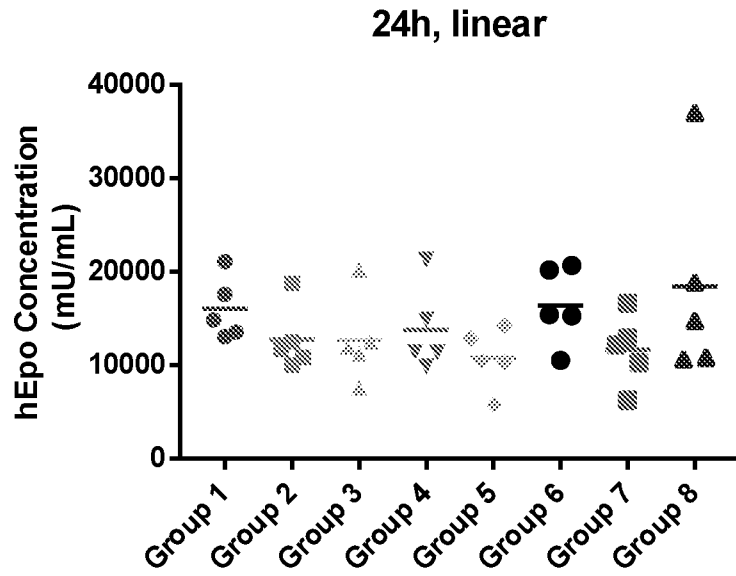

Figure 46

Figure 47A

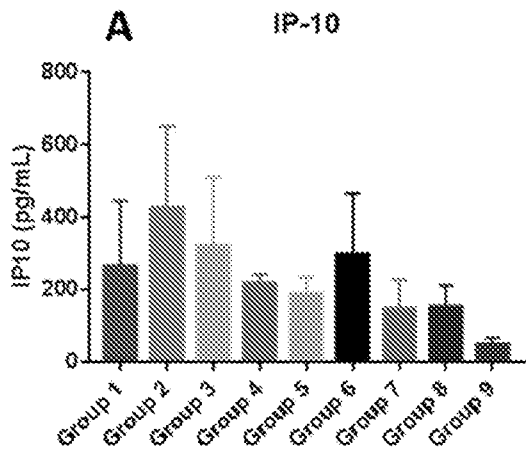
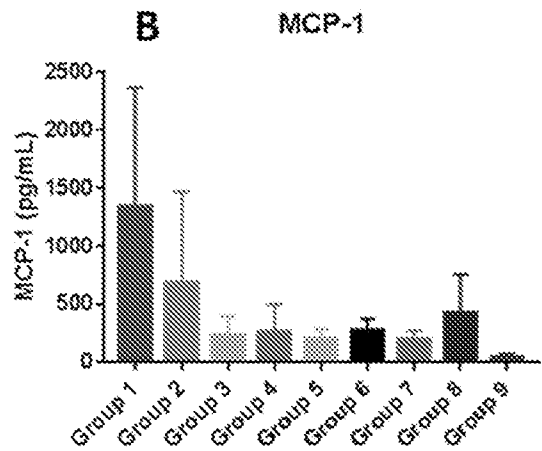

Figure 47B



36/44

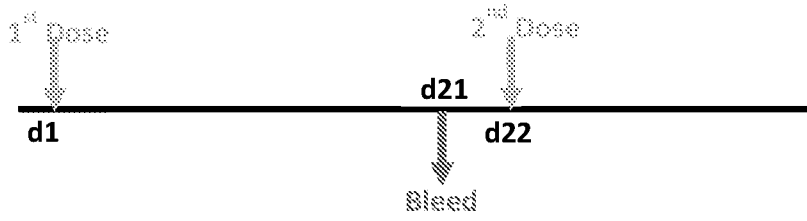

Figure 48

Dose 2 Particle Count >0.8 μm

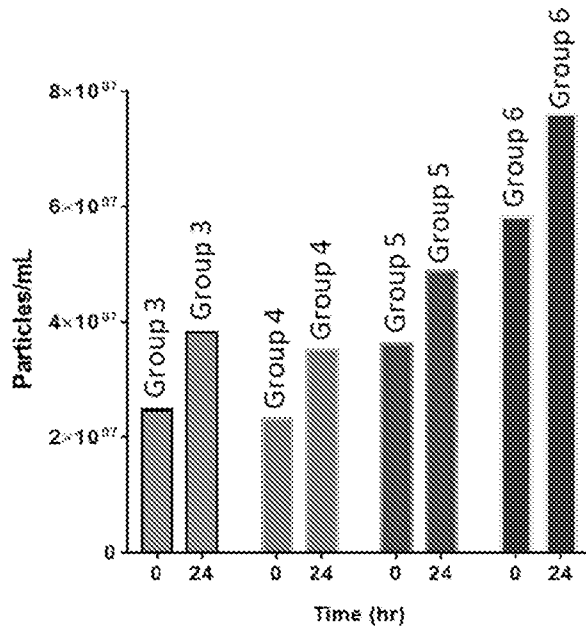

Figure 49

37/44

Dose 2 Particle Count >2 μm

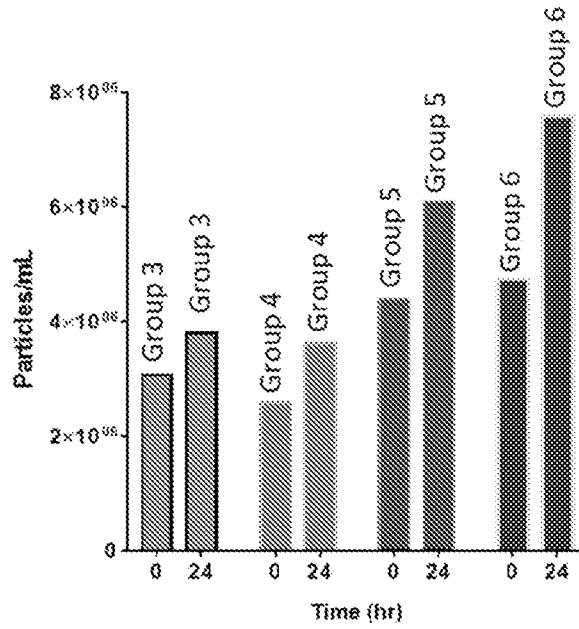

Figure 50

- ◆ D21 (3 weeks post prime) IgG (pentamer)
- D36 (2 weeks post boost)

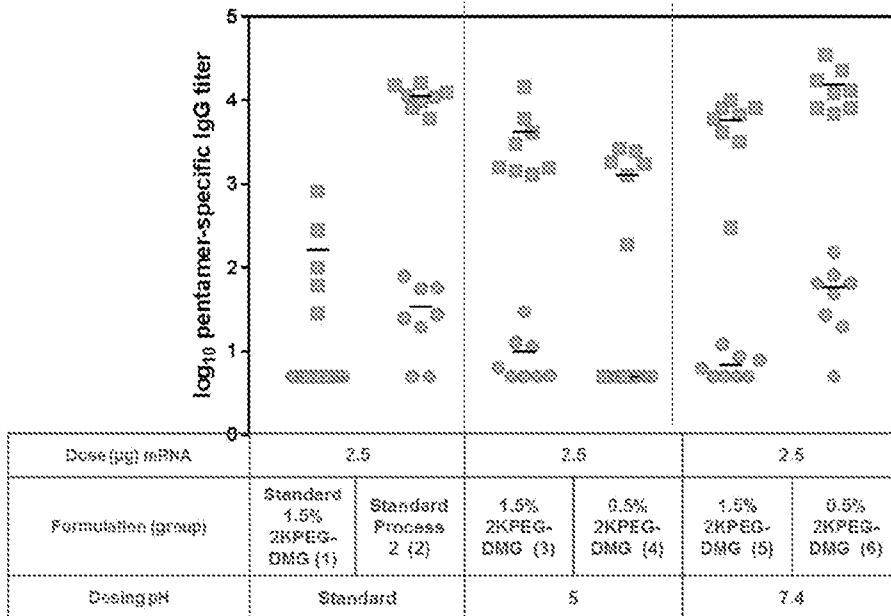

Figure 51

38/44

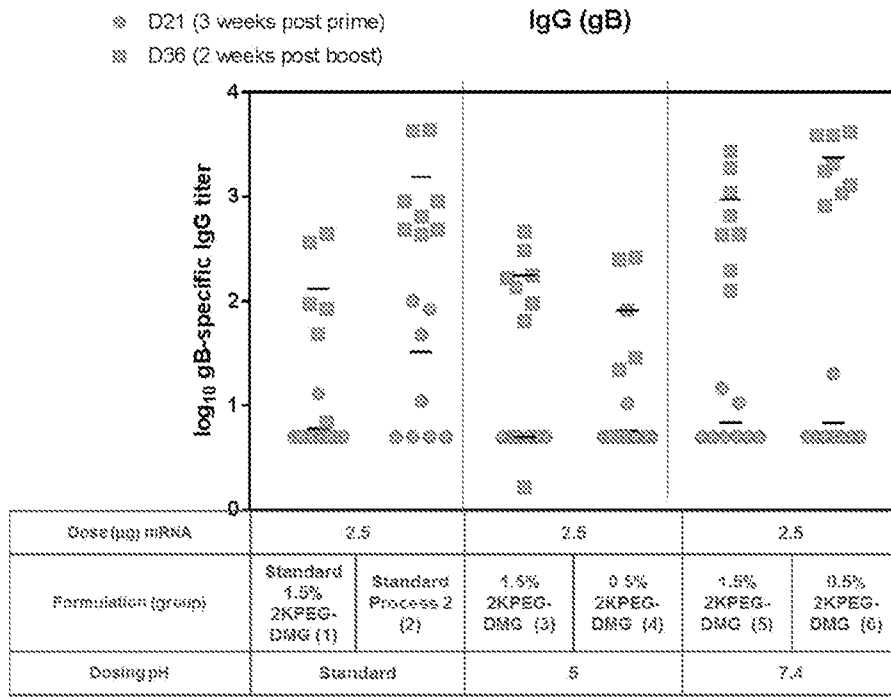

Figure 52

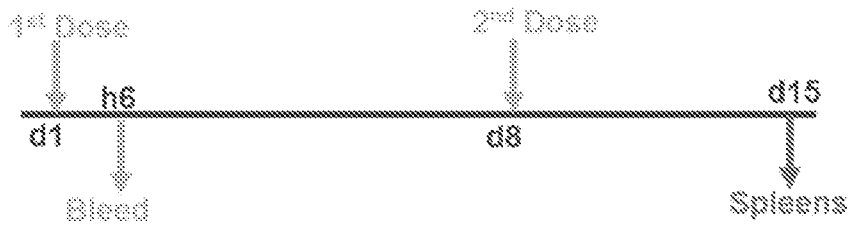

Figure 53

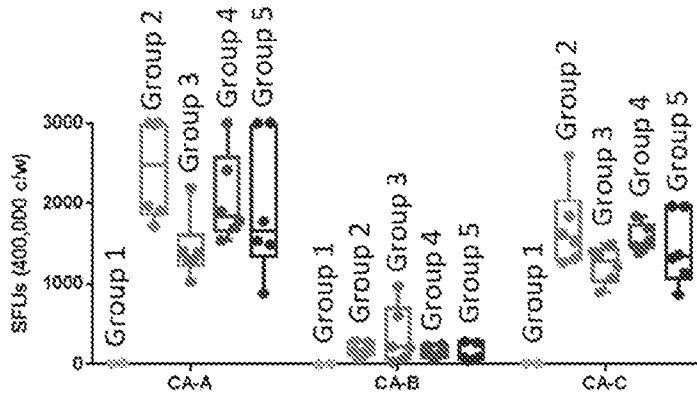

Figure 54

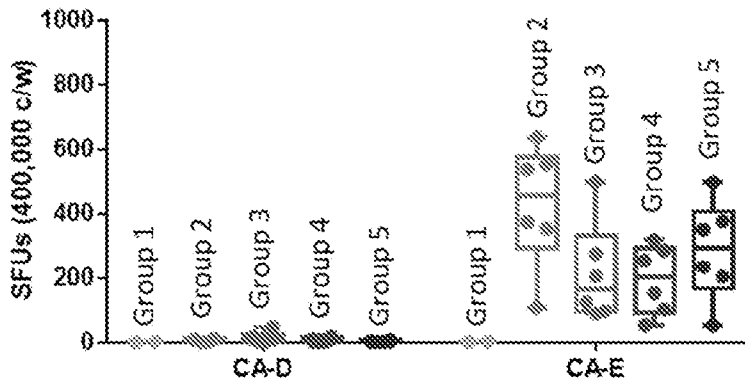

Figure 55

40/44

Whole Body, 6h

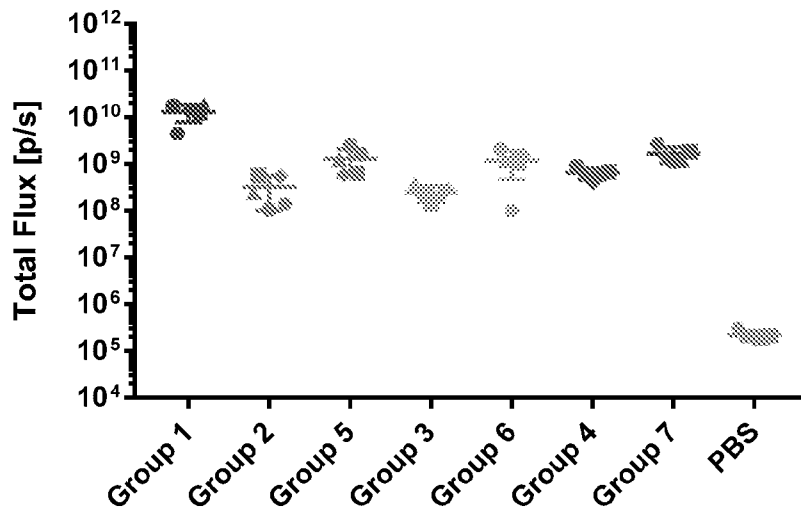

Figure 56

ExVivo Liver, 6h

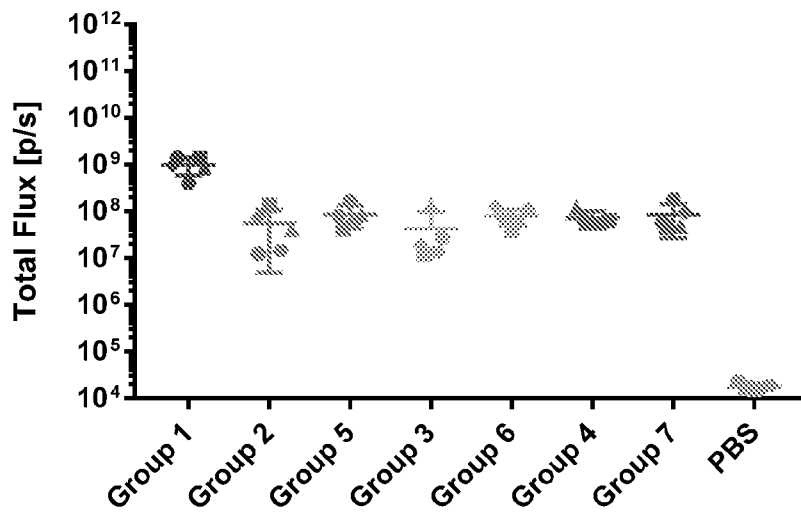

Figure 57

41/44

ExVivo Spleen, 6h

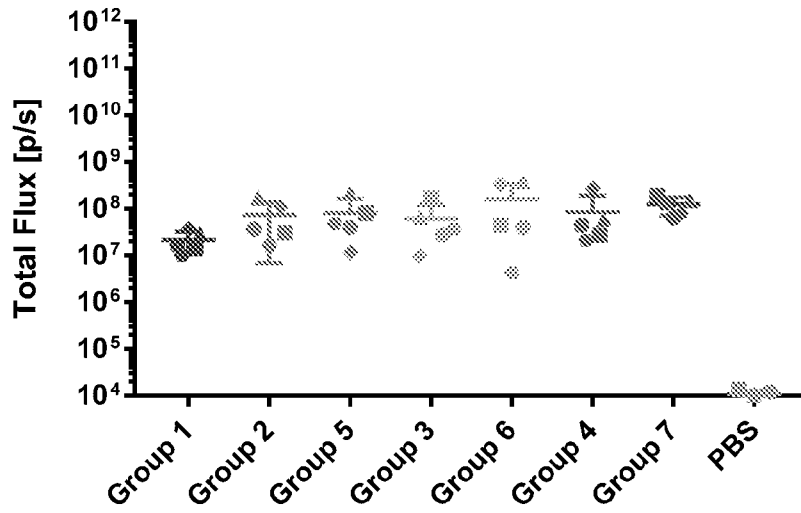

Figure 58

ExVivo Lung, 6h

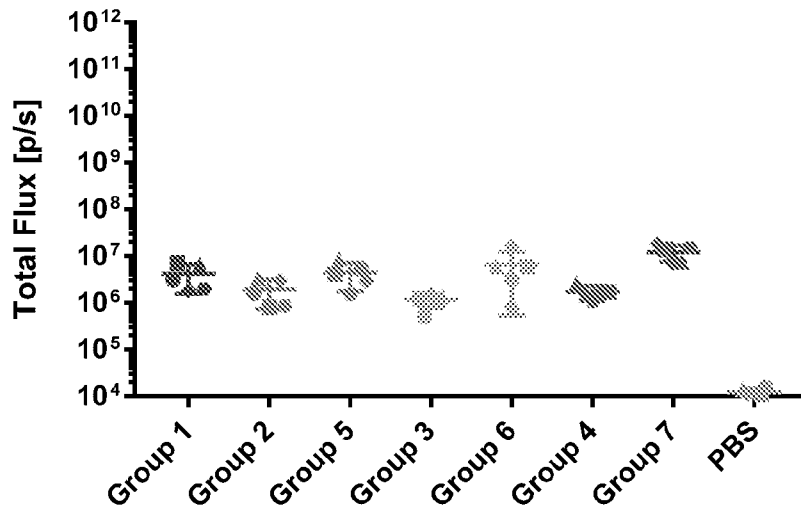

Figure 59

42/44

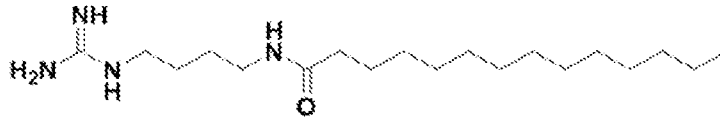

Figure 60

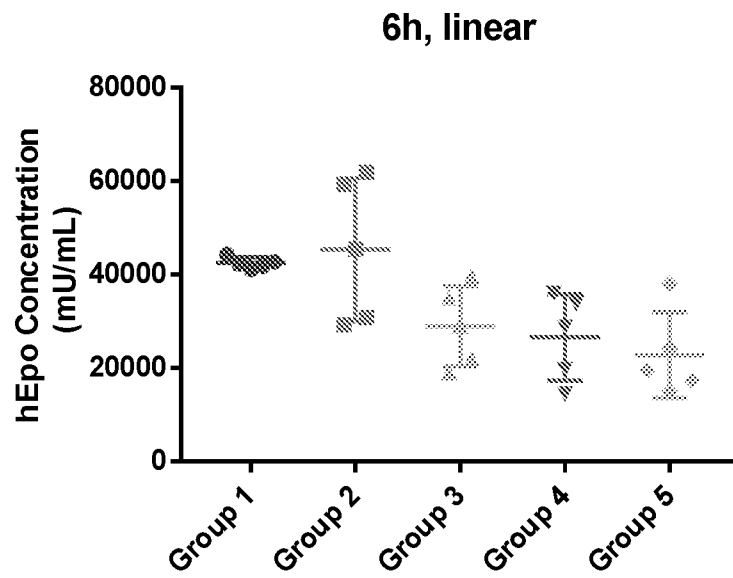

Figure 61

43/44

24h, linear

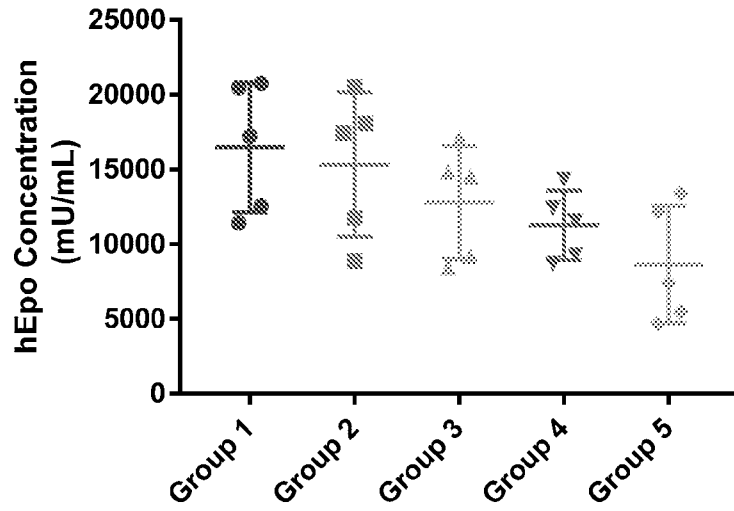

Figure 62

IP-10

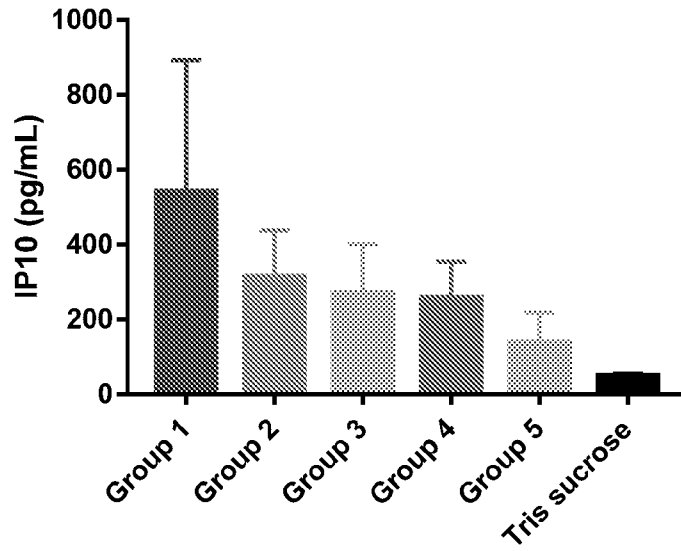

Figure 63

44/44

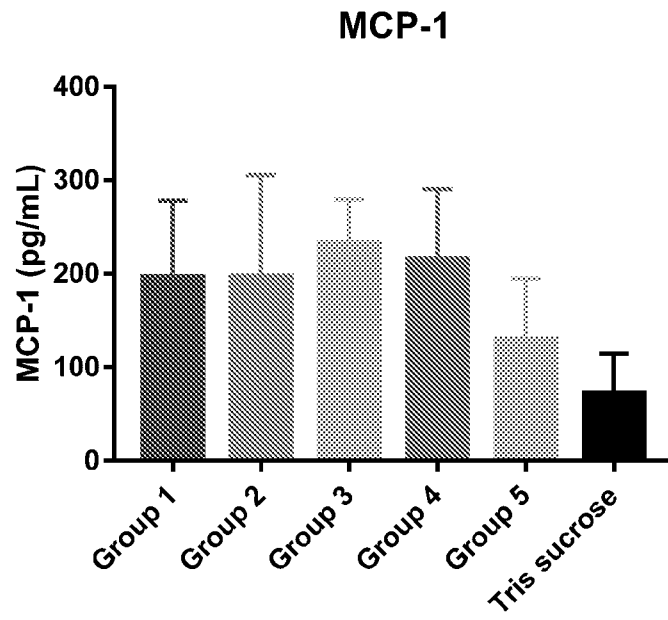

Figure 64

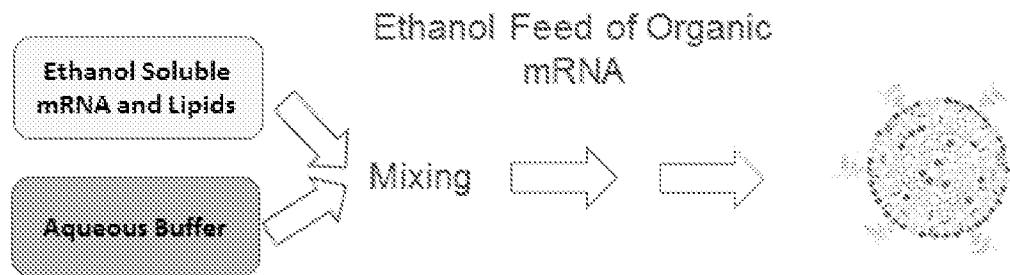
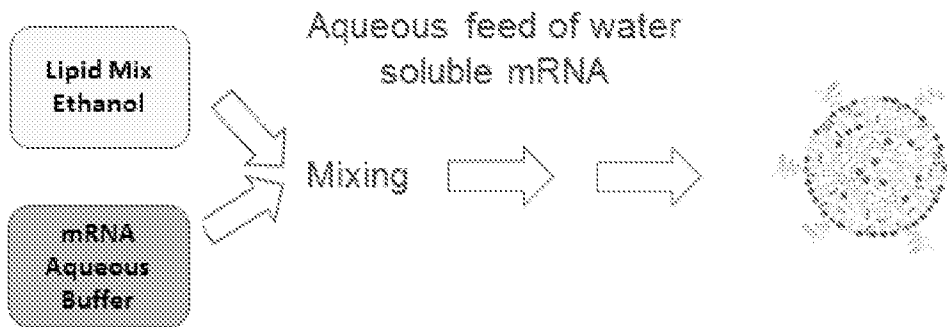

Figure 1