



(11) **EP 2 240 660 B1**

(12) **EUROPEAN PATENT SPECIFICATION**

(45) Date of publication and mention of the grant of the patent:
22.02.2012 Bulletin 2012/08

(21) Application number: **09705886.1**

(22) Date of filing: **19.01.2009**

(51) Int Cl.:
E05D 15/10 (2006.01)

(86) International application number:
PCT/IB2009/000103

(87) International publication number:
WO 2009/095755 (06.08.2009 Gazette 2009/32)

(54) **DEVICE FOR SUPPORTING AND ACTUATING SLIDABLE DOORS FOR WARDROBES**

VORRICHTUNG ZUM HALTEN UND BETÄTIGEN VON SCHIEBETÜREN FÜR KLEIDERSCHRÄNKE
DISPOSITIF DE SUPPORT ET D'ACTIONNEMENT DE PORTES COULISSANTES POUR ARMOIRES

(84) Designated Contracting States:
AT BE BG CH CY CZ DE DK EE ES FI FR GB GR HR HU IE IS IT LI LT LU LV MC MK MT NL NO PL PT RO SE SI SK TR

(30) Priority: **28.01.2008 IT PN20080003**

(43) Date of publication of application:
20.10.2010 Bulletin 2010/42

(73) Proprietor: **Intechse Innovation & Technology Service di Fornasari Paolo & C. S.a.s. 33084 Cordenons (PN) (IT)**

(72) Inventor: **Fornasari, Paolo 33084 Cordenons (PN) (IT)**

(74) Representative: **Dalla Rosa, Adriano SEBRINT Via del Troi, 2 33170 Pordenone (IT)**

(56) References cited:
CH-A5- 616 720 DE-A1-102006 049 479 GB-A- 2 146 517

EP 2 240 660 B1

Note: Within nine months of the publication of the mention of the grant of the European patent in the European Patent Bulletin, any person may give notice to the European Patent Office of opposition to that patent, in accordance with the Implementing Regulations. Notice of opposition shall not be deemed to have been filed until the opposition fee has been paid. (Art. 99(1) European Patent Convention).

Description

[0001] The present invention refers to a support and actuation arrangement for the sliding doors of wardrobes and similar cabinets having doors of a kind capable of sliding in an alternate longitudinal direction along upper and lower rectilinear rails, that are applied to run along the ceiling and the bottom of the related cabinet, respectively, wherein such doors are capable of being actuated at the same time to symmetrically slide, i.e. following symmetrical sliding directions, from the opened position to the closed position thereof, and vice-versa.

[0002] From CH 616720 A5 is known a support and actuation device for a wardrobe cabinet provided with three front sliding doors having first upper and slide means, of the upper portion of the doors, second lower support and slide means of the lower portion of the doors, wherein the first and second support and slide means are adapted to support the relative door when the same is shifted in the closed or opened position thereof and to guide the alternate longitudinal sliding movement of the door, and wherein the doors are also further provided with a third upper support and slide means of the upper portion of the door and with a fourth lower support and slide means of the lower portion of the door, which third and fourth support and slide means are adapted to support the doors when the same are shifted in the closed or opened position thereof and are further adapted to determine the alternate sliding movement of the doors transversally in the depth direction of the cabinet to and from said closed and opened position thereof.

[0003] The doors are also provided with fifth guide and synchronism means cooperating with said third upper support and slide means and fourth support and slide means to enable respectively said upper and lower portion of the doors to slide in a synchronized manner transversally in the depth direction of the cabinet to and from said closed and opened position of the same doors.

[0004] The object of the present invention is to provide a support and actuation arrangement for slidable doors of wardrobes and similar cabinets, which makes use of mechanisms that are made in a manner different than those disclosed by CH 616720 A5.

[0005] According to the present invention, this aim is reached in a support and actuation arrangement for slidable doors of wardrobes and similar cabinets, which incorporates the features and characteristics as recited in the appended claims.

[0006] Further features and advantages of the present invention will anyway be readily understood from the description that is given below by way of non-limiting example with reference to the accompanying drawings, in which:

- Figure 1 is a perspective front elevational view of a wardrobe incorporating the door support and actuation arrangement according to a preferred embodiment of the present invention, in which all doors are

moved and set in the closed position thereof;

- Figure 2 is a perspective rear elevational view of the wardrobe shown in Figure 1;
- Figure 3 is a perspective front elevational view of the wardrobe shown in Figure 1, in which a door is shown to be shifted into a half-opened position;
- Figure 4 is a plan view of the wardrobe shown in Figure 3;
- Figure 5 is a perspective rear view of a first component part of the door support and actuation arrangement according to a preferred embodiment of the present invention, as applied onto the top portion of the wardrobe illustrated in Figure 1;
- Figure 6 is perspective rear view of an enlarged construction detail of Figure 5;
- Figure 7 is a perspective bottom rear view of a second component part of the door support and actuation arrangement according to a preferred embodiment of the present invention, as applied onto the bottom portion of the wardrobe illustrated in Figure 1;
- Figure 8 is perspective rear view of an enlarged construction detail of Figure 7;
- Figure 9 is a perspective front view of a third component part of the door support and actuation arrangement according to a preferred embodiment of the present invention;
- Figure 10 is a perspective rear view of the third component part shown in Figure 9;
- Figure 11 is a perspective front view of a fourth component part of the door support and actuation arrangement according to a preferred embodiment of the present invention, as applied onto the top portion of the wardrobe illustrated in Figure 1;
- Figure 12 is an exploded perspective rear view of the fourth component part of the arrangement shown in Figure 11, as it is being assembled onto the wardrobe shown in Figure 1;
- Figure 13 is a perspective front view of a fifth component part of the door support and actuation arrangement according to a preferred embodiment of the present invention, as applied onto the bottom portion of the wardrobe illustrated in Figure 1;
- Figure 14 is an exploded perspective front view of the fifth component part of the arrangement shown in Figure 13, as it is being assembled onto the wardrobe shown in Figure 1;
- Figure 15 is an exploded perspective rear view of the fifth component part of the arrangement shown in Figures 13 and 14;
- Figure 16 is a perspective front view of a sixth component part of the door support and actuation arrangement according to a preferred embodiment of the present invention;
- Figure 17 is an enlarged perspective front view of two construction details of the sixth component part shown in Figure 16;
- Figure 18 is a perspective front view of one of the construction details shown in Figure 17, as it is being

- assembled onto the wardrobe shown in Figure 1;
- Figure 19 is a front cross-sectional view along the line A-A of the construction detail shown in Figure 18;
 - Figure 20 is a front cross-sectional view along the line B-B of the construction detail shown in Figure 18;
 - Figure 21 is a perspective rear view of the construction detail shown in Figure 18, as shifted in an operating position thereof;
 - Figure 22 is a perspective rear view of the construction detail shown in Figure 18, as shifted in another operating position thereof;
 - Figures 23, 24 and 25 are perspective front views of three possible embodiments, respectively, of the sixth component part of the door support and actuation arrangement according to a preferred embodiment of the present invention;
 - Figure 26 is a perspective front view of a further possible embodiment of the sixth component part of the door support and actuation arrangement according to a preferred embodiment of the present invention;
 - Figure 27 is a perspective front view of the sixth component part shown in Figure 26, as viewed in the assembled state thereof for mounting on to a wardrobe;
 - Figures 28 and 29 are enlarged exploded perspective views of the upper portion and the lower portion, respectively, of the component part shown in Figure 27;
 - Figure 30 is a perspective rear view of the upper portion of the sixth component part of the inventive arrangement, in another modified embodiment thereof, as viewed in a state in which it is shifted in an operating position thereof;
 - Figure 31 is a perspective rear view of the upper portion shown in Figure 30, as shifted in another operating position thereof;
 - Figure 32 is a side cross-sectional view of all component parts of the system used for moving the door of the wardrobe shown in Figure 1 forwards, as viewed in the assembled state thereof and with the door moved outwards relative to the wardrobe cabinet;
 - Figure 33 is a same view as the one shown in Figure 32 of the wardrobe cabinet comprising the same component parts as the ones illustrated in Figure 32, in which the door, however, lies close to the wardrobe cabinet;
 - Figure 34 is a perspective front view of the two different construction details of the first component part of the door support and actuation arrangement according to a preferred embodiment of the present invention, which is mounted on to the door of the wardrobe shown in Figure 1;
 - figure 35 is an exploded perspective rear view of a construction detail of the fifth component part of the door support and actuation arrangement according to a preferred embodiment of the present invention;
 - Figure 36 is a same view as the one shown in Figure 35 of the same construction detail as assembled into the wardrobe and shifted into an operating position thereof;
 - Figure 37 is a same view as the one shown in Figure 35 of the same construction detail as assembled into the wardrobe and shifted into another operating position thereof;
 - Figure 38 is a side cross-sectional view of the fourth component part of the arrangement, as assembled onto the wardrobe as shown in Figure 12 and shifted into an operating position thereof;
 - Figure 39 is a same view as the one shown in Figure 38 of the same component part shifted into another operating position thereof;
 - Figure 40 is a same view as the one shown in Figure 38 of the same component part shifted into a further operating position thereof;
 - Figure 41 is a perspective front view of the fourth component part of the inventive arrangement, as shifted into the operating position shown in Figure 40;
 - Figure 42 is a perspective front view of the wardrobe incorporating the door support and actuation arrangement according to the present invention in a modified embodiment thereof and with one of its doors shifted into an operating position thereof;
 - Figures 43 and 44 are a same view as the one shown in Figure 42 of the wardrobe shown in Figure 42, with its door viewed in two different steps as it is being shifted towards the other operating position thereof;
 - Figure 45 is a same view as the one shown in Figure 42 of the wardrobe having its door shifted into the other operating position thereof.
- [0007]** Illustrated in the above-listed Figures is a support and actuation arrangement for the sliding doors of wardrobe cabinets according to a preferred embodiment of the present invention, which is made and operates in the manner as described below, and which is adapted to support and slidably actuate the cabinet doors in alternate longitudinal directions into mutually co-planar positions, wherein such doors are actuated at the same time and move from a closed position, in which the doors are close to each other and aligned with each other relative to the front plane of the wardrobe cabinet, to an opened position, in which such doors are first shifted slightly forwards and then caused to slide sideways into the desired position in a parallel relation with the front plane of the wardrobe cabinet.
- [0008]** In particular, illustrated in Figures 1 and 2 there are three similar wardrobe cabinets 5 in a perspective front view and a perspective rear view thereof, respectively, wherein these cabinets are joined to each other in a juxtaposed arrangement. Each such cabinet is shown to incorporate the door support and -actuation arrangement according to the present invention, wherein each such wardrobe cabinet 5 in the illustrated example is provided with a front planar door 6 provided with two side

door handles 7 and 8 for shifting the door and cause it to slide in an alternate longitudinal direction; in the above-cited illustrations, the doors 6 of all cabinets 5 are shown to be shifted into their closed position, in which they are arranged so as to lie aligned with each other, thereby forming a smooth planar front face of the cabinet assembly. In addition, each wardrobe cabinet 5 is delimited by a rear wall 9 extending parallel to the door 6, a planar top ceiling 10, a planar lower bottom 11, and two side walls, wherein in the example illustrated in Figures 1 to 4 there can be noticed the outer side walls 12 and 13 delimiting the two outer sides of the corresponding cabinets joined with each other, and two inner side walls 14 and 15 delimiting each cabinet in the assembly. Shown again in Figures 3 and 4 there is the same assembly of the three similar wardrobe cabinets 5 illustrated in Figures 1 and 2. In this case, however, one of the cabinet doors, and namely the door of the middle cabinet in the example illustrated, is shown to be shifted into a half-opened position thereof in the manner as described in greater detail further on. In this position, such door turns out as being displaced forwards relative to the other doors lying in the closed position thereof. In this condition, it is then caused to slide sideways until the desired opened position thereof is reached. Finally, when such door has eventually to be brought again into its closed position, it is caused to slide back thereinto by following the same movements in the reverse sequence thereof.

[0009] Described in detail will now be the actual arrangement for supporting and actuating the sliding door of each wardrobe cabinet in the assembly, wherein such arrangement is substantially comprised of a first component part (see Figures 5 and 6) applied on to the upper side of the planar ceiling 10 of the cabinet; a second component part (see Figures 7 and 8) applied on to the planar bottom plate 11 of the cabinet; a third component part (see Figures 9 and 10) applied on to the rear wall of the cabinet; a fourth component part (see Figures 11 and 12) applied on to the planar ceiling 10 of the cabinet, as well; a fifth component part (see Figures 13 to 15) applied on to the planar bottom plate 11 of the cabinet, as well; and a sixth component part (see Figures 16 to 29) adapted to guide and synchronize the sliding movement of each door.

[0010] The first component part is substantially formed of a metal profile section 16 (see Figures 5 and 6) having the same length as each door 6 and configured to include a vertical rectilinear planar portion 17, which is fixedly secured to the upper portion of each door by means of screws 18 and bent inwardly, i.e. towards the interior of the cabinet, and supporting at the end portion thereof a further vertical rectilinear profile section 19 of aluminium or thermoplastic material, which is so shaped as to have a lower groove 20 formed therein and extending over the whole length thereof, such first component part being further comprised of an angle metal section 21 in an elongated rectilinear shape, which has the same length as the profile section 16 and is configured to include a hor-

izontal portion 22, which is secured to the front edge of the ceiling 10 of the cabinet, and an upwards facing short vertical portion 23, so as to be able to guide the alternate longitudinal sliding movement of the upper portion of the door 6 in the manner that shall be described in greater detail further on. In turn, the second component part is substantially comprised of an angle section 24 of metal or thermoplastic material (see Figures 7 and 8), having a rectilinear horizontal extension over a same length as the length of each door 6 and so shaped as to include a short horizontal portion 25, which is joined to the lower portion of each door 6 by means of brackets 26, and which is bent upwards to form a short vertical portion 27 acting as a guide, or runner, for the door to be able to perform the alternate longitudinal sliding movement thereof in the manner that shall be described in greater detail further on.

[0011] The third component part is substantially comprised of a robust vertical metal profile section 28 (see Figures 9 and 10) having a length that is equal to the height of the cabinet, which is secured in an intermediate position against the rear wall 9 of each cabinet so as to extend all over the height of such rear wall (see also Figure 2), wherein the upper and lower end portions thereof are bent horizontally and configured in the manner and to the purposes that shall be described and explained in greater detail further on.

[0012] The fourth component part is substantially comprised of an upper skid 29 (see Figure 11 and 12) adapted to allow the upper portion of each door 6 to perform the alternate longitudinal sliding movement thereof and substantially comprised of an elongated rectilinear metal profile section 30 having a length that is slightly shorter than the length of each door 6 and so shaped as to include a front planar edge 31 in which there are pivotally hinged, in a freely rotatable manner, various rather thin wheels 32 regularly spaced from, similar to and aligned with each other, which are adapted to slide in an alternate longitudinal direction along the corresponding groove 20 in the profile section 19 that is secured, jointly with the profile section 16, to the upper portion of each door 6. This elongated rectilinear metal profile section 30 is further provided with two side wheels 33, which are similar to each other and are pivotally hinged in a freely rotatable manner at the side end portions of the same profile section in an orthogonal position relative to the above-cited wheels 32; additionally, it is also provided with two further wheels 34, similar and situated close to each other, that are pivotally hinged in a freely rotatable manner in the lower planar edge 35 of the profile section with a downward-facing orientation, wherein all these wheels are provided to the purposes that shall be described in greater detail further on. The elongated profile section 30 of the above-described skid is further joined with a middle rectilinear transverse profile section 36 that is bent downwards so as to delimit an inner cavity opening downwards, wherein such profile section is arranged orthogonally to said elongated profile section, at the rear thereof, thereby forming

a T-shaped structure, and extends over the entire depth of each cabinet; between these profile sections 30 and 36 there is further secured a reinforcement and stiffening structure formed of two inclined profile sections 37 and 38 in a mutually symmetrical arrangement. The free rear end portion of the transverse profile section 36 is inserted onto the corresponding bent upper end portion of the vertical profile section 28, by which it is therefore supported, and this end portion of the vertical profile section 28 is provided with an actuation mechanism that is so shaped and configured as this shall be described in greater detail further on, wherein such mechanism is adapted to cause the assembly formed by the transverse profile section 36 and the skid 29 to displace, jointly with the door 6, by just a limited extent in the alternate transversal direction of each cabinet.

[0013] The upper skid 29 is laid to rest upon and fixed with the lower edge 35 thereof to the planar horizontal portion 22 of the angle section 21 and cannot displace from such position owing to the side wheels 33 thereof, which are resting against corresponding raised portions 39 of such planar horizontal portion 22 of the angle section 21, and the lower wheels 34 thereof, which engage, on both sides thereof, a middle rib 40 provided transversally on the same planar horizontal portion of the angle section, and owing also to the upper skid 29 being laterally delimited by the vertical section portion 23 and a further short vertical portion 41 of the afore-cited profile section 16 formed along the other side edge of the above-cited planar horizontal section portion 22 in a position lying parallel to said vertical section portion 23. The upper skid 29 is kept in this position also by means of the transverse profile section 36 joined to the same skid, the free rear end portion of which is caused to pass through a bracket 42 attached to the ceiling 10 of the cabinet, by which such profile section 36 is therefore supported, and in this bracket 42 there are pivotally hinged in a freely rotatable manner and in mutually opposing positions two vertical-axis idle wheels 43 and 44 acting from both sides against the related side surface of the transverse profile section 36, to the purpose of guiding the sliding movement of the profile section in the transversal direction of the cabinet, in the manner and to the purposes that shall be described in greater detail further on, as well as preventing the same profile section from displacing in the longitudinal direction of the cabinet. The longitudinal sliding movement of the door 6 in each cabinet occurs by placing the profile section 16 supporting the door 6 in a position above and corresponding to the upper skid 29, while fitting all idle wheels 32 of such skid in the groove 20 defined by the vertical profile section 19. In this condition, this profile section 19 will then be able to slide on all above-cited idle wheels in the longitudinal direction of the cabinet, wherein it will, be guided in this sliding movement thereof by a guide plane formed of a sequence of regularly spaced guide wheels 45 provided in a mutually aligned arrangement and pivotally hinged in a freely rotatable manner in the vertical portion 23 of such angle

section 21 in positions that are parallel to the ones of the wheels 32 of the upper skid.

[0014] In the condition in which the door 6 of each cabinet is closed, the skid 29-transverse profile section 36 assembly is displaced rearwards in the transverse direction of the cabinet, in the position shown in Figure 38, in which all idle wheels 32 of the upper skid 29 are engaged in the groove 20 of the vertical profile section 19, whereas the wheels 45 of the angle section 21 are not engaged therein, so that such wheels 45 solely perform as a guide plane for the longitudinal sliding movement of the profiler section 19 and, as a result, the corresponding sliding movement of the door 6. In the condition in which the door 6 of each cabinet is open, i.e. a condition that is reached by acting on the handle of the door and pulling such door forwards, the skid 29-transverse profile section 36 assembly is displaced forwards in the transverse direction of the cabinet, jointly with the door 6, and shifted into the position illustrated in Figure 39, in which the vertical profile section 19 and the related groove 20 come to be also aligned with the idle wheels 45 of the angle section 21, so that, in this position, to be engaged in the groove 20 of the vertical profile section 19 there are not solely the wheels 32 of the upper skid 29, but also the wheels 45 of the angle section 21, during the longitudinal sliding movement of the profile section 19 and, as a result, the door 6 shifted into the opened position thereof lying over the front plane of the cabinet in front thereof. Upon having slidably displaced the door into the desired opening position in the above-described manner, the same door can be of course caused to slide back into the afore-described closed position thereof in the reverse sequence of the above-described movements.

[0015] With reference to Figures 13-15, the fifth component part of the door support and actuation arrangement according to a preferred embodiment of the present invention shall now be illustrated. This fifth component part is substantially comprised of a lower skid 46 adapted to allow the lower portion of each door 6 to perform the alternate longitudinal sliding movement thereof and substantially comprised of an elongated angle section 47 having the same length as the door and located in a position lying under the bottom 11 of the cabinet, this elongated angle section being further shaped so as to include a planar vertical portion 48 that is bent at the upper portion thereof to form a short horizontal planar portion 49, said elongated angle section being further provided in the middle region thereof with two similar idle wheels 50 situated close to each other and pivotally hinged in a freely rotatable manner, and being joined with a transverse profile section 51 arranged orthogonally to said elongated profile section, at the rear thereof, thereby forming a T-shaped structure, and extends over the entire depth of each cabinet; as in the preceding case, between these profile sections 47 and 51 there is further secured a reinforcement and stiffening structure formed of two inclined profile sections 52 and 53 in a mutually symmetrical arrangement. The free rear end portion of the trans-

verse profile section 51 is inserted onto the corresponding bent lower end portion of the vertical profile section 28, by which it is therefore supported, and this end portion of the vertical profile section 28 is provided with an actuation mechanism similar to the afore-considered upper one, as this shall anyway be described in greater detail further on, adapted to cause the assembly formed by the transverse profile section 51 and the lower skid 46 to displace, jointly with the door 6, by just a limited extent in the alternate transversal direction of each cabinet, synchronously with the movement of the upper assembly formed of the transverse profile section 36 and the upper skid 29. Against the front surface of the vertical planar portion 48 of the angle section 47 there are secured and supported two similar shoes 54 and 55, in the side position of said angle section, wherein each such shoe is shaped so as to include a rectilinear shank 56, which is applied and appropriately secured against said front angle-section surface, as well as two short side shanks 57 similar to each other and projecting forwards from the same section, said side shanks being so spaced from each other as to form a free space therebetween, in which there is accommodated a related idle roller 58 supported by a short arm 59 secured against the angle section 47 and provided there to the purposes that shall be described in greater detail further on. In each one of said side shanks 57 of the shoes 54 and 55 there is provided a slit 60 extending thereunder and through all such slits 60 of the shoes 54 and 55 there is fitted the vertical portion 27 of the angle section 24, which is joined against the lower portion of the door 6, so that the same door is allowed to slide in the longitudinal direction through all slits 60, which therefore perform as a support and a sliding guide for the door. Onto the horizontal planar portion 49 of the lower skid 46 there is applied an angle section 61 having the same length as said skid, wherein this angle section is so shaped as to include a horizontal planar portion 62, having a greater width than the horizontal portion 49 of the skid 46 thereunder, and a vertical and front planar portion 63, wherein the horizontal portion 62 of the angle section 61 is provided with side flanks 64 and 65 that are so bent as to form a respective short horizontal planar border 66 and 67; these borders are fitted onto the corresponding side end portion of the horizontal portion 49 of the lower skid 46 lying thereunder, thereby joining the angle section 61 lying thereabove and said skid 46 with each other. In this condition, the upper wheels 50 of the lower skid 46 come to rest against the sides of a transverse rib 68 formed in the lower surface of the horizontal portion 62 of the angle section under the bottom 11 of the cabinet.

[0016] In turn, laterally against the rear surface of the vertical angle-section portion 63 there are applied two vertical shoes 69 and 70 similar to each other, the purpose of which shall be described in greater detail further on; each such shoe is comprised of a respective rear quadrangular plate 71 (see Figures 35 to 37) attached against the vertical angle-section portion 63, as well as

a front moveable quadrangular plate 72, which is arranged above the rear plate 71 and supported by the latter so as to be able to slide relative thereto by a limited extent in the vertical direction, by means of a linkage system of a kind largely known as such in the art, along corresponding vertical guides 73 provided on the same rear plate, wherein both such plates are made so as to have a width enabling them to fit into the free space defined between the side shanks 57 of the respective shoes 54 and 55, and each movable front plate 72 is so shaped over the entire width thereof to include a rear and lower front recess 74 (see also Figures 32 and 33) and a thin projecting front lug 75 provided with a wall 76 slanting with an inclination rising from the bottom upwards, which is situated in a position opposite to and coincident with the position of the idle roller 58 of the respective shoe 54, 55, so as to interact with such idle roller in a manner that shall be described in greater detail further on. Each front plate 72 is furthermore provided with an upper receptacle 77 adapted to receive and accommodate the end portion of a corresponding compression spring 78, the other end, portion of which is accommodated in the lower surface of the horizontal angle-section portion 62, and this movable front plate is displaceable from a lowered position thereof, as illustrated in Figures 8, 15 and 33, in which it is biased into such position by the spring 78 when the door 6 is shifted in the closed position thereof, to the raised position thereof shown in Figure 32 against the action of said spring 78, which is compressed, when the door 6 is shifted into the opened position thereof. The lower skid 46 is kept in the above-described position also by the effect of the transverse profile section 51 joined to the same skid and bent upwards to delimit an inner cavity opening upwards, and the free rear end portion of such transverse profile section 51 is caused to pass through a bracket 79, similar to and arranged symmetrically relative to the previously described bracket 42, which is attached to both the bottom 11 of the cabinet and the profile section 51, and pivotally hinged in a freely rotatable manner to such bracket 79 in mutually opposing positions there are two vertical-axis idle wheels 80 and 81 acting from both sides against the related side surface of the transverse profile section 51, and also in this case there occurs a sliding movement of the profile section by just a limited extent in the transversal direction of the cabinet, in the manner and to the purposes that shall be described in greater detail further on, while the same profile section is prevented from displacing in the longitudinal direction of the cabinet.

[0017] With reference to Figures 16 to 29, the sixth component part of the door support and actuation arrangement according to the present invention shall now be illustrated in various embodiments thereof. In particular, illustrated in Figures 16 to 23 there is this sixth component part in a first embodiment thereof, wherein it can be noticed to be substantially comprised of a first upper horizontal-axis cylindrical roller 82 pivotally hinged in a rotatable manner between two parallel and mutually

spaced shanks 83 and 84 of a metal bracket 85 attached to the upper end portion of the vertical profile section 28 of each cabinet, wherein such cylindrical roller is co-axially aligned and cooperates with the respectively opposite transverse profile section 36 attached to the cabinet, and wherein such cylindrical roller is further firmly joined with a rotating pulley 86 pivotally hinged on to the shank 84 of the bracket 85 and connected with motion transmission systems that shall be described in greater detail further on. Furthermore, the cylindrical roller is so shaped as to include a double-start helical groove 87 extending all along the peripheral surface thereof. In turn, at the free end portion thereof facing the cylindrical roller 82, the hollow transverse profile section 36 is provided with two short rectilinear pins 88 and 89, which are similar to, aligned with and slightly spaced from each other, and which are fitted transversally through the wall of the same profile section and are so sized as to ensure that they keep constantly engaging the helical groove 87 of the cylindrical roller 82 regardless of the rotational position thereof. As already noted hereinbefore, the transverse profile section 36 can be displaced jointly with the door 6 in the transverse direction of the cabinet by acting on the handle of the same door and, in particular, when the door 6 is shifted backwards into its closed position, the transverse profile section 36 is displaced in the same direction, too, by sliding along the cylindrical roller 82 that rotates in a corresponding direction, jointly with the related pulley 86, with the result that also the associated motion transmission system will slide in the same direction, until the free end portion of the transverse profile section 36 comes to rest against the abutment position (see Figure 21), in which the door 6 is closed. On the other hand, when the door 6 is shifted from the closed position to the opened position thereof by first displacing the same door forwards relative to the cabinet, the transverse profile section 36 will slide along the cylindrical roller 82 in the reverse direction, and the same roller rotates, jointly with the related pulley 86, in the opposite direction as compared with the previous one, with the result that also the associated motion transmission system will slide in the same direction, until the free end portion of the transverse profile section 36 comes to rest against the other abutment position (see Figure 22), in which the door 6 is fully open.

[0018] The sixth component part of the inventive door support and actuation arrangement is further comprised of a second lower horizontal-axis cylindrical roller 90 similar to and mounted in a parallel arrangement relative to the above-described roller and, as in the case of the latter, supported by two parallel and mutually spaced shanks 91 and 92 of a metal bracket 93 attached to the lower end portion of the vertical profile section 28 of each cabinet in an overturned position as compared with the afore-described bracket 85, wherein such cylindrical roller is co-axially aligned and cooperating with the respectively opposite transverse profile section 51 attached to the cabinet, and wherein such cylindrical roller is further firm-

ly joined with a rotating pulley 94 pivotally hinged on to the shank 92 of the bracket 93 and connected with the same motion transmission system that is connected with the upper pulley 86. Furthermore, the cylindrical roller is so shaped as to include a double-start helical groove 95 extending all along the peripheral surface thereof with the same winding pattern as the helical groove 87 of the upper roller 82. As in the previous case, also this lower cylindrical roller 90 is engaged by two short rectilinear pins (not shown), which are fitted through the wall of the transverse profile section 51 and are so sized as to ensure that they keep constantly engaging the helical groove 95 of the cylindrical roller 90 regardless of the rotational position thereof. In this manner, when the door 6 is shifted into either of the closed or opened positions thereof by acting on the handle of the same door, also the transverse profile section 51 is displaced in the same direction by sliding along the cylindrical roller 90 that rotates in a corresponding direction, jointly with the related pulley 94, with the result that also the associated motion transmission system will move in the same direction along with the opposite pulley 86, the upper cylindrical roller 82 and the upper transverse profile section 36. In these conditions, the door 6 is displaced at both the lower portion thereof, by means of the lower transverse profile section 51 and the lower cylindrical roller 90, and the upper portion thereof, by means of the upper transverse profile section 36 and the upper cylindrical roller 82, with a synchronized movement.

[0019] Figure 23 solely illustrates the upper rotating pulley 86 of the upper cylindrical roller 82, in the race 96 of which there are wound several turns of a flexible steel cord 97 forming the motion transmission system to and from the upper transverse profile section 36 and the lower transverse profile section 51, said flexible steel cord being also wound in the same manner round the other pulley 94 of the lower cylindrical roller 90.

[0020] Shown in Figure 24 is the motion transmission system used as a motion transmission means to and from said upper and lower transverse profile sections, in a second embodiment thereof. In this case, the motion transmission system is comprised of a cog belt 98 wound round a corresponding rotating cog-pulley 99 co-axially coupled to the upper cylindrical roller 82, and such cog belt is also wound round the other rotating cog-pulley (not shown) that is co-axially coupled to the lower cylindrical roller 90. Shown in Figure 25 is the motion transmission system used as a motion transmission means to and from said upper and lower transverse profile sections, in a third embodiment thereof, wherein such motion transmission system is in this case comprised of a metal perforated strap 100 wound round a corresponding rotating cog-pulley 101 co-axially coupled to the upper cylindrical roller 82, and such perforated strap is also wound round the other rotating cog-pulley (not shown) that is co-axially coupled to the lower cylindrical roller 90. A further embodiment of the motion transmission system used as a motion transmission means to and from said upper

and lower transverse profile sections is shown in Figures 26 to 31, wherein such motion transmission system is in this case comprised again of a flexible steel cord 97, which is wound round the races 102 of two upper horizontal-axis pulleys 103 similar to each other and firmly joined with each other in a coaxial arrangement relative to each other, which are rotatably hinged on to the upper end portion of the vertical profile section 28 of each cabinet (see Figures 27 and 28), and said flexible steel cord is also wound round the race 104 of a vertical-axis deviation pulley 105 that is rotatably hinged on to a support bracket 106 attached to said upper end portion of the vertical profile section 28 and a securing bolt 107 that is inserted transversally in the profile section 36. Furthermore, the steel cord 97 is also wound round the races 108 of two lower horizontal-axis pulleys 109 similar to each other and firmly joined with each other in a coaxial arrangement relative to each other, which are rotatably hinged on to the lower end portion of the vertical profile section 28 (see Figure 29), and also in this case said flexible steel cord is wound round the race 110 of a vertical-axis deviation pulley 111 that is rotatably hinged on to a support bracket 112 attached to said lower end portion of the vertical profile section 28, and the securing bolt 107 is inserted transversally in the transverse profile section 51. Figures 30 and 31 illustrate this motion transmission system using such flexible steel cord 97, as installed on the upper portion of the wardrobe cabinet. It can be noticed that the flexible steel cord 97 is deviated round the two upper horizontal-axis pulleys 103 and the vertical-axis deviation pulley (not to be seen in the Figures) rotatably hinged on to the bracket 106, and is secured with the related bolt 107 in the transverse direction of the upper profile section 36. so that this profile section 36 can still be displaced, in the afore-described manner, from the closed position of the door 6 in Figure 30 to the opened position of the same door in Figure 31, and vice-versa. It can on the other hand be most readily appreciated that the motion transmission system used as a motion transmission means to and from said upper and lower transverse profile sections 36, 51 may also be embodied using any other motion transmission member or means as largely known as such in the art and differing from the ones that have been described above by mere way of illustrative example, without this meaning any departure from the scope of the present invention, as defined by the claims.

[0021] Illustrated in greater detail in Figure 34 are the two different construction members making up the structure of the metal profile section 16 that forms the first component part of the inventive door support and actuation arrangement, which has been already described hereinbefore with reference to Figures 5 and 6 and, for the matter, substantially comprised of both said profile section 16, as shaped in the afore-described manner and attached to the upper portion of the door 6, and a rectilinear vertical profile section 19 secured to said profile section 16 and provided with a lower groove 20 for the

door to slide therein, as well as an angle section 21 attached to the ceiling 10 of the cabinet. As can be seen in this Figure, the profile section 16 is provided with a sequence of through-apertures 114 regularly spaced from each other over the entire length of the same profile section, the purpose of which consists in enabling the front wheels 45 rotatably hinged on to the angle section 21 to be received and accommodated there in the closed condition of the door (see Figure 38), as well as enabling also the front wheels 32 of the upper skid 29 to be received and accommodated there in the opened condition of the door (see Figures 39 to 41), in which said wheels 32 move into an arrangement in which they are longitudinally aligned with the wheels 45. In turn, the rectilinear vertical profile section 19 is so shaped all along the longitudinal extension thereof as to include an upper recess 115 that is fitted into the rectilinear bent border 116 of the profile section 16, thereby securing these profile sections to each other, and is further so shaped as to include the afore-described lower slit or groove 20, as well as a sequence of semi-circular recesses 117 provided all along a front face of the same profile section and regularly spaced from each other with a centre-to-centre distance between them that is equal to the one between the wheels 45, so as to be able to fit onto the corresponding front wheels 45 of the profile 16 in the closed position of the door 6.

[0022] Finally, illustrated in Figures 32 to 37 is the lower portion of the door 6 and the manner in which it is shifted from its closed position (see Figure 33), on the front side of the wardrobe cabinet, and into its opened position (see Figure 32). As can be seen in the illustration of Figure 33, where the door 6 is shown to be shifted in the closed position thereof, the angle section 24, which is secured to the lower portion of the door 6 by means of brackets 26, engages with the vertical portion 27 thereof the slits 60 in the shoes 54 and 55, which are secured to the angle section 47, to thereby be firmly retained there without being able to displace. In this condition, the middle roller 58 of each skid lies aligned with and spaced from the projecting lug 75 and the slanting wall 76 of the respective movable front plate 72 of the vertical shoes 69 and 70, which are applied against the angle section 61 attached to the lower skid 46, and such movable plate 72 is kept in its lowered resting position by the spring 78. When the door 6 is then shifted from the closed position into the opened position thereof, with a forward movement on the front side of the wardrobe cabinet, also the assembly comprised of the shoes 54 and 55 and the middle roller 58 is at the same time displaced forwards gradually by the action of the angle section 24 engaging the same shoes, whereas the angle section 61 and the movable front plate assembly 72 keep at rest, i.e. do not move. In this manner, the middle roller 58 moves gradually closer to the projecting lug 75 and the related slanting wall 76 and, as soon as it comes to abut against the slanting wall 76, it starts sliding thereupon, so that, as the roller 58 keeps in this way sliding forwards, it causes the projecting

lug 75 to gradually rise jointly with the related movable plate 72, which in turn causes the spring 78 to become gradually compressed, thereby clearing the rectilinear sliding path of the brackets 26 and the angle section 24. When the door 6 reaches into its opening position, in which it is fully displaced forwards (see Figure 32), the movable plate 71 of the vertical shoes 69 and 70 is fully lifted by the roller 58, so that the angle section 24 is able to freely move into the end-of-travel or abutment position thereof, in which its vertical portion 27 fits into the lower recess 74 of the related movable plate 71. In this condition, the opened door can be caused to slide sideways into the desired position, thanks to the vertical portion 27 of the angle section 24 being thus able to slide on the vertical shoes 69 and 70, wherein it is guided and held in position by the slits 60 in the shanks 57.

[0023] For the door to be then brought back into the closing position thereof, all it takes is pushing the same door towards the interior of the cabinet until it reaches such position, wherein all above-cited mechanic members will displace in the reverse order of the moving sequence.

[0024] In the modified embodiment of the door support and actuation arrangement which does not form part of the present invention and illustrated in Figures 42 to 45, there have been omitted the metal vertical profile section 28 of the third component part, as well as The motion transmission members 82, 90, 103, 105, 109 and 111 which, as associated with such vertical profile section 28 and the upper and lower transverse profile sections 36, 51, have been shown to be provided to guide and synchronize the movements of the door 6. In this manner, the displacements of each door 6 being actuated into closing or opening occur in this case with different movements that are no longer synchronized with each other. When each door is displaced in the closed position thereof, as shown in Figure 42, the door can be actuated into opening by first pulling its handle outwardly so as to first of all displace a side of the door, i.e. the lower side in the example being described (see Figure 43), until the related abutment is reached and the door is now inclined frontwards, and then pulling the remaining side of the door, i.e. the upper side in this case (see Figure 44), outwardly until the related abutment is reached, under a corresponding inclination of the door, so that, as soon as these movements are completed, the door turns out as being displaced frontwards in a parallel arrangement relative to the remaining doors of the wardrobe, in a condition in which it is ready for being shifted sideways.

[0025] Shown in Figure 45 there is finally the door 6 in the condition in which it is fully shifted sideways, i.e. to the right side in this case, so that the inner cavity of the wardrobe cabinet is accessible. Shifting the door into its closed position is done through a reverse sequence of the above-described movements, wherein the door is first caused to slide into its closing position, in which it is displaced frontwards in front of the inner cavity of the cabinet, and then pushing inwardly first a side and then the

other side of the door until the respective abutments are reached, thereby bringing the door back into the fully closed position thereof shown in Figure 42. Displacing the door into opening or closing through the sequence of the above-described movements can occur by initially displacing either of the lower or upper portions thereof and then displacing the remaining one.

10 Claims

1. Support and actuation device for the sliding doors (6) of wardrobe cabinets (5), wherein each cabinet (5) comprises a planar front face (6), a rear wall (9), a planar top ceiling (10), a planar lower bottom (11) and two side walls (12, 13), and each door (6) is provided with handles (7, 8) for it to be shifted from a closed position, in which it is slightly receded in the depth direction of the cabinet (5) relative to the front face thereof, into an opened position, in which it is first displaced frontwards by a limited extent in the depth direction of the cabinet (5), relative to the front face thereof, and is then caused to rectilinearly slide sideways into the desired position in a parallel arrangement relative to the front face of the cabinet (5), and then shifted back into its closed position through a reverse sequence of the above-described movements, comprising first upper support and slide means (16, 19, 21) of the upper portion of the door (6), which are adapted to support said upper door portion in the cabinet (5) when the door (6) is shifted in the closed or opened position thereof, and which are further adapted to guide the alternate longitudinal sliding movement of said upper door portion in the cabinet (5) when the door (6) is shifted in the opened position thereof; second lower support and slide means (24) of the lower portion of the door (6), which are adapted to support said lower door portion in the cabinet (5) when the door (6) is shifted in the closed or opened position thereof, and which are further adapted to guide the alternate longitudinal sliding movement of said lower door portion in the cabinet (5) when the door (6) is shifted in the opened position thereof; third upper support and slide means (29, 36) of the upper portion of the door (6), which in use are applied on to the top ceiling (10) of the cabinet (5) and adapted to support said upper door portion in the cabinet (5) when the door (6) is shifted in the closed or opened position thereof, and which are further adapted to determine the sliding movement of the door (6) transversally in the depth direction of the cabinet (5) to and from said closed and opened position thereof, and further adapted to determine the alternate longitudinal sliding movement of said upper door portion in the cabinet (5) when the door (6) is shifted in the opened position thereof; fourth lower support and slide means (46, 51) of the lower portion of the door (6), which in use are applied on

to the bottom (11) of the cabinet (5) and adapted to support said lower door portion in the cabinet (5) when the door (6) is shifted in the closed or opened position thereof, and which are further adapted to determine the sliding movement of the door (6) transversally in the depth direction of the cabinet (5) to and from said closed and opened position thereof, and further adapted to determine the alternate longitudinal sliding movement of said lower door portion in the cabinet (5) when the door (6) is shifted in the opened position thereof; and comprising fifth guide and synchronism means (28; 82, 90; 103, 105; 109, 111) cooperating with said third upper support and slide means (29, 36) and said fourth lower support and slide means (46, 51) to enable said upper portion and said lower portion of the door, respectively, to slide in a synchronized manner transversally in the depth direction of the cabinet (5) to and from said closed and opened positions of the same door, **characterized in that** said first upper support and slide means comprise a metal profile section (16) configured to include a vertical rectilinear planar portion (17), which in use is fixedly secured to the upper portion of each door (6) and bent inwardly towards the interior of the cabinet, and which supports at an end portion thereof a further vertical rectilinear profile section (19), which is so shaped as to include a lower groove (20) formed therein and extending over the whole length thereof, and further comprise an angle section (21) in an elongated rectilinear shape, which is configured to include a horizontal portion (22), which in use is secured to the top ceiling (10) of the cabinet, and an upwards facing short vertical portion (23), in which there rotatably hinged a sequence of guide wheels (45) similar to and regularly spaced from each other, which are provided in a mutually aligned arrangement along said vertical portion (23), and **characterized in that** said third upper support and slide means comprise an upper skid (29) comprised of an elongated rectilinear metal profile section (30), and a middle rectilinear transverse profile section (36) joined transversally to said elongated profile section (30), at the rear thereof, so as to form a T-shaped structure therewith, and extending over the entire depth of each cabinet (5), said elongated profile section (30) being provided with a sequence of front, freely rotatable idle wheels (32) similar to, regularly spaced from and aligned with each other along the same profile section (30), as well as freely rotatable idle side wheels (33) and lower wheels (34), said elongated profile section (30) being secured to said horizontal profile-section portion (22) of said first upper support and slide means, which is also engaged by said side wheels (33) and lower wheels (34), in such manner as to ensure that said front idle wheels (32) will constantly engage said lower groove (20) of said vertical rectilinear profile section (19) of said first upper support and slide means, in the

closed or opened position of said door (6), said elongated profile section (30) being displaceable in the transverse direction of the cabinet (5) jointly with said transverse profile section (36) and the upper portion of said door (6) so that, in the opened position of said door (6), also said guide wheels (45) of said angle section (21) are engaging said lower groove (20) of said vertical rectilinear profile section (19), and the door (6) is able to slide sideways into the desired opening position, the related sliding movement being guided by the guide plane formed of such guide wheels (45).

2. Device according to claim 1, **characterized in that** said second lower support and slide means comprise an angle section (24) of metal or thermoplastic material, having a rectilinear horizontal extension, and so shaped as to include a short portion (25), which in use is joined to the lower portion of each door (6) by means of brackets (26), and which is bent upwards to form a short vertical portion (27).
3. Device according to claim 2, **characterized in that** said fourth lower support and slide means comprise a lower skid (46) comprised of an elongated metal angle section (47), and a middle rectilinear transverse profile section (51) joined transversally to said elongated angle section (47), at the rear thereof, so as to form a T-shaped structure therewith, and extending over the entire depth of each cabinet (5), said elongated angle section (47) being shaped so as to include a planar vertical portion (48) that is bent to form a short horizontal upper planar portion (49), and being further provided in the middle region thereof with lower idle wheels (50) hinged in a freely rotatable manner thereto, said elongated angle section (47) joining with an angle section (61) thereabove, which is in turn so shaped as to include a horizontal planar portion (62) and a vertical and front planar portion (63), and is secured under the bottom (11) of the cabinet (5), said vertical portions (48, 63) of the respective angle sections (47, 61) being provided with guide and slide means (54, 55; 69, 70) that cooperate with each other and are adapted to support the angle section (24) of the second lower support and slide means in the closed or opened position of said door (6), and are further adapted to guide said door (6) in the alternate longitudinal movement thereof into the opened position thereof.
4. Device according to claim 3, **characterized in that** said guide and slide means of the fourth lower support and slide means comprise a pair of shoes (54, 55) secured in a mutually spaced arrangement against the front surface of said vertical portion (48) of said angle section (47), and so shaped as to include side shanks (57) projecting forwards and engaging the vertical portion (27) of said angle section

(24) of the second lower support and slide means, in both said closed and opened positions of the door (6), the side shanks (57) of each such shoe being spaced to accommodate an idle roller (58) projecting forwards, and secured to said vertical portion (48), therebetween, said guide and slide means further comprising a pair of vertical shoes (69, 70) secured in a mutually spaced arrangement against the rear surface of said vertical portion (63), in positions coincident with the positions of said shoes (54, 55), and provided with a plate (72) that is movable in the vertical direction and cooperates with elastic means (spring 78), as well as so shaped as to include a front projecting lug (75) provided with a slanting wall (76) facing the corresponding projecting roller (58), the arrangement being such that, when the door (6) is shifted towards the opened position thereof, each projecting roller (58), by acting against said respective slanting wall (76), causes said movable plates (72) to be gradually lifted upwards against the action of said elastic means (78), thereby enabling said vertical portion (27) of said angle section (24) of the second lower support and slide means to displace against the related vertical shoes (69, 70), and the open door to subsequently slide sideways relative to the same shoes.

5. Device according to claims 1, 3 and 4, **characterized in that** said fifth guide and synchronism means comprise motion transmission means (82, 90; 103, 105; 109, 111) attached to the upper end portion and the lower end portion of at least one vertical section (28), which is secured to the rear wall (9) of each cabinet (5) and extends over the full height of the same cabinet (5), and cooperating with the respective free rear end portions of the upper transverse profile section (36) of the third upper support and slide means and said lower transverse profile section (51) of the fourth lower support and slide means so that, as said door (6) is being shifted from one to the other of said closed or opened positions thereof by operating it through the handle thereof, the resulting transverse displacement in the same direction of said upper and lower transverse profile sections (36, 51) occurs in a synchronized manner through said motion transmission means (82, 90; 103, 105; 109, 111).
6. Device according to claim 5, **characterized in that** said motion transmission means comprise a first upper horizontal-axis rotating cylindrical roller (82) rotatably hinged on to the upper end portion of said vertical profile section (28) and co-axially aligned with said upper transverse profile section (36) of said third upper support and slide means, as well as joined with an upper rotating pulley (86), and further comprise second lower horizontal-axis rotating cylindrical roller (90) rotatably hinged on to the lower

end portion of said vertical profile section (28) and co-axially aligned with said lower transverse profile section (51) of said fourth lower support and slide means, as well as joined with a lower rotating pulley (94), which is connected with said upper rotating pulley (86) via a steel cord (97), a cog belt (98), a strap (100), or the like, and **characterized in that** each one of said first and second cylindrical rollers (82, 90) is so shaped as to include a double-start helical groove (87, 95) extending all along the peripheral surface thereof, said groove engaging rectilinear transverse pins (88, 89) of said upper and lower transverse profile sections (36, 51).

7. Device according to claim 5, **characterized in that** said motion transmission means comprise a pair of upper horizontal-axis rotating pulleys (103) and a vertical-axis rotating deviation pulley (105) that are rotatably hinged on to the upper end portion of said vertical profile section (28), and a pair of lower horizontal-axis rotating pulleys (108) and a vertical-axis rotating deviation pulley (111) that are rotatably hinged on to the lower end portion of said vertical profile section (28), and are joined with each other via a steel cord (97), or the like, engaging said upper transverse profile section (36) and said lower transverse profile section (51), respectively, with the aid of a bolt (107) or the like.
8. Device according to any of the preceding claims, **characterized in that** the profile section (16) of the first upper support and slide means is provided with a sequence of through-apertures (114), regularly spaced from each other over the entire length of the same profile section, for said front wheels (45) of the angle section (21) of said first upper support and slide means to be received and accommodated there, as well as for the front wheels (32) of said upper skid (29) to be received and accommodated there when said door (6) is in the opened condition thereof and said wheels (32) move into an arrangement in which they are longitudinally aligned with said wheels (45), and **characterized in that** said profile section (19) of said first upper support and slide means is so shaped in the lower portion thereof as to include a sequence of semi-circular recesses (117) provided all along a front face of the same profile section and regularly spaced from each other with a centre-to-centre distance between them that is equal to the one between said wheels (45), so as to be able to fit onto said front wheels (45) when the door (6) is shifted in the closed position thereof.

55 Patentansprüche

1. Halte- und Betätigungsvorrichtung für die Schiebetüren (6) von Kleiderschrankzellen (5), wobei jede

Zelle (5) eine ebene Frontfläche (6), eine Rückwand (9), eine ebene obere Decke (10), einen ebenen unteren Boden (11) und zwei Seitenwände (12,13) hat, und jede Tür (6) mit Handgriffen (7,8) versehen ist, damit sie aus einer geschlossenen Position, in der sie etwas zurück versetzt ist, in der Tiefenrichtung der Zelle (5) relativ zu deren Frontfläche, in eine geöffnete Position zu verschieben ist, in der sie zuerst in einem begrenzten Ausmaß in der Tiefenrichtung der Zelle (5) relativ zu deren Frontfläche nach vorne versetzt und dann veranlasst ist, geradlinig seitlich in die gewünschte Position in einer parallelen Anordnung relativ zu der Frontfläche der Zelle (5) zu gleiten, und dann durch eine umgekehrte Reihenfolge der oben beschriebenen Bewegungen in die geschlossene Position verschoben wird, enthaltend erste obere Halte- und Gleitmittel (16, 19, 21) des oberen Abschnitts der Tür (6), die geeignet sind, den oberen Türabschnitt in der Zelle (5) zu halten, wenn die Tür (6) in ihre geschlossene oder geöffnete Position verschoben ist, und die außerdem geeignet sind, die alternierende longitudinale Gleitbewegung des oberen Türabschnitts in der Zelle (5) zu führen, wenn die Tür (6) in ihre geöffnete Position verschoben wird;

zweite untere Halte- und Gleitmittel (24) des unteren Abschnitts der Tür (6), die geeignet sind, den unteren Türabschnitt in der Zelle (5) zu halten, wenn die Tür (6) in ihre geschlossene oder offene Position verschoben ist und die ferner geeignet sind, die alternierende longitudinale Gleitbewegung des unteren Türabschnitts in der Zelle (5) zu führen, wenn die Tür (6) in ihre geöffnete Position verschoben wird;

dritte obere Halte- und Gleitmittel (29,36) des oberen Abschnitts der Tür (6), die beim Gebrauch auf der oberen Decke (10) der Zelle (5) angebracht sind und geeignet sind, den oberen Türabschnitt in der Zelle (5) zu halten, wenn die Tür (6) in ihre geschlossene oder geöffnete Position verschoben ist, und die ferner geeignet sind, die Gleitbewegung der Tür (6) transversal in der Tiefenrichtung der Zelle (5) in und aus ihrer geschlossenen und geöffneten Position festzulegen, und die ferner geeignet sind, die alternierende longitudinale Gleitbewegung des oberen Türabschnitts in der Zelle (5) festzulegen, wenn die Tür (6) in ihre geöffnete Position verschoben wird;

vierte untere Halte- und Gleitmittel (46,51) des unteren Abschnitts der Tür (6), die beim Gebrauch an dem Boden (11) der Zelle angebracht sind, und die geeignet sind, den unteren Türabschnitt in der Zelle (6) zu halten, wenn die Tür (6) in ihre geschlossene oder geöffnete Position verschoben ist, und die ferner geeignet sind, die Gleitbewegung der Tür (6) transversal in der Tiefenrichtung der Zelle (5) in und aus ihrer geschlossenen und geöffneten Position festzulegen, und ferner geeignet sind, die alternierende longitudinale Gleitbewegung des unteren Türabschnitts in der Zelle (5) festzulegen, wenn die Tür

(6) in ihre geöffnete Position verschoben wird; und enthaltend fünfte Führungs- und Synchronisierungsmittel (28;82,90;103, 105;109,111), die mit den dritten oberen Halte- und Gleitmitteln (29,36) und den vierten unteren Halte- und Gleitmitteln (46,51) zusammenwirken, um es dem oberen Abschnitt und dem unteren Abschnitt der Tür zu ermöglichen, auf synchronisierte Weise transversal in der Tiefenrichtung der Zelle (5) in und aus der geschlossenen und geöffneten Position der Tür zu gleiten, **dadurch gekennzeichnet, dass** die ersten oberen Halte- und Gleitmittel einen metallischen Profilabschnitt (16) aufweisen, der konfiguriert ist, einen vertikalen geradlinigen ebenen Abschnitt (17) zu enthalten, der beim Gebrauch an dem oberen Abschnitt jeder Tür (6) fest angebracht und zu dem Inneren der Zelle einwärts gebogen ist, und der an einem Endabschnitt davon einen weiteren vertikalen geradlinigen Profilabschnitt (19) hält, der so geformt ist, dass er eine untere Nut (20) enthält, die darin geformt ist, und sich über dessen ganze Länge erstreckt und ferner einen Winkelabschnitt (21) in einer langgestreckten geradlinigen Form enthält, der konfiguriert ist, einen horizontalen Abschnitt (22) zu enthalten, der beim Gebrauch an der oberen Decke (10) der Zelle befestigt ist, und einen nach oben weisenden kurzen vertikalen Abschnitt (23), in dem eine Folge von Führungsrädern (45) drehbar gehalten sind, die zueinander gleich und gleichmäßig voneinander beabstandet sind, die in einer zueinander ausgerichteten Anordnung entlang des vertikalen Abschnitts(23) vorgesehen sind, und **dadurch gekennzeichnet, dass** die dritten oberen Halte- und Gleitmittel eine obere Schiene (29) enthalten, die aus einem lang gestreckten geradlinigen Metallprofilabschnitt (30) und einem mittleren geradlinigen transversalen Profilabschnitt (26) besteht, der transversal mit dem lang gestreckten Profilabschnitt (30) verbunden ist, an dessen Rückseite, um so damit eine T-förmige Struktur zu bilden, und sich über die gesamte Tiefe jeder Zelle (5) erstreckt, wobei der lang gestreckte Profilabschnitt (30) mit einer Folge von vorderen, frei drehbaren Leerlaufrädern (32) versehen ist, die einander gleich und gleichmäßig voneinander beabstandet und entlang des Profilabschnitts (30) aufeinander ausgerichtet sind, sowie mit frei drehbaren Leerlaufseitenrädern (33) und unteren Rädern (34), wobei der lang gestreckte Profilabschnitt (30) an dem horizontalen Profilabschnittteil (22) der ersten oberen Halte- und Gleitmittel befestigt ist, der außerdem im Eingriff mit den Seitenrädern (33) und unteren Rädern (34) auf solche Weise steht, um zu gewährleisten, dass die vorderen Leerlaufräder (32) stets in die untere Nut (20) des vertikalen geradlinigen Profilabschnitts (19) der oberen Halte- und Gleitmittel in der geschlossenen oder offenen Position der Tür (6) eingreifen, wobei der lang gestreckte Profilabschnitt (30) in der Querrich-

- tung der Zelle (5) gemeinsam mit dem transversalen Profilabschnitt (36) und dem oberen Abschnitt der Tür (6) verschiebbar ist, so dass in der offenen Position der Tür (6) auch die Führungsräder (45) des Winkelabschnitts (21) in die untere Nut (20) des vertikalen geradlinigen Profilabschnitts (19) eingreifen und die Tür (6) in der Lage ist, seitwärts in die gewünschte Öffnungsposition zu gleiten, wobei die zugehörige Gleitbewegung durch die Führungsebene geführt wird, die durch die Führungsräder (45) gebildet ist.
2. Vorrichtung nach Anspruch 1, **dadurch gekennzeichnet, dass** die zweiten unteren Halte- und Gleitmittel einen Winkelabschnitt (24) aus Metall oder thermoplastischem Material aufweisen, der eine geradlinige horizontale Erstreckung hat und so geformt ist, dass er einen kurzen horizontalen Abschnitt (25) enthält, der beim Gebrauch mit dem unteren Abschnitt jeder Tür (6) mit Hilfe von Bügeln verbunden ist und nach oben gebogen ist, um einen kurzen vertikalen Abschnitt (27) zu bilden.
3. Vorrichtung nach Anspruch 2, **dadurch gekennzeichnet, dass** die vierten unteren Halte- und Gleitmittel eine untere Schiene (46) aufweisen, die einen lang gestreckten metallischen Winkelabschnitt (47) aufweist, und einen mittleren geradlinigen transversalen Profilabschnitt (51), der transversal mit dem langgestreckten Winkelabschnitt (47) an dessen Rückseite verbunden ist, um so damit eine T-förmige Struktur zu bilden, die sich über die gesamte Tiefe jeder Zelle (5) erstreckt, wobei der lang gestreckte Winkelabschnitt (47) so geformt ist, dass er einen ebenen vertikalen Abschnitt (48) enthält, der gebogen ist, um einen kurzen horizontalen oberen ebenen Abschnitt (49) zu bilden, und wobei ferner in dem mittleren Bereich davon untere Leerlaufrollen (50) vorgesehen sind, die auf eine frei drehbare Weise daran angebracht sind, wobei der lang gestreckte Winkelabschnitt (47) mit einem Winkelabschnitt (61) da oben verbunden ist, der seinerseits so geformt ist, dass er einen horizontalen ebenen Abschnitt (62) und einen vertikalen und vorderen ebenen Abschnitt (63) enthält, und unter dem Boden (11) der Zelle (5) befestigt ist, wobei die vertikalen Abschnitte (48,63) der jeweiligen Winkelabschnitte (47,61) mit Führungs- und Gleitmitteln (54, 55; 69,70) versehen sind, die miteinander zusammen wirken und geeignet sind, den Winkelabschnitt (24) der zweiten unteren Halte- und Gleitmittel in der geschlossenen oder geöffneten Position der Tür (6) zu halten, und ferner geeignet sind, die Tür (6) in der alternierenden longitudinalen Bewegung in die geöffnete Position zu führen.
4. Vorrichtung nach Anspruch 3, **dadurch gekennzeichnet, dass** die Führungs- und Gleitmittel der vierten unteren Halte- und Gleitmittel ein Paar Auf-lagerschuhe (54,55) aufweisen, die in zueinander beabstandeter Anordnung an der Vorderseite des vertikalen Abschnitts (48) des Winkelabschnitts (47) befestigt und so geformt sind, dass sie seitliche Schenkel (57) haben, die nach vorne abstehen und den vertikalen Abschnitt (27) des Winkelabschnitts (24) der zweiten unteren Halte- und Gleitmittel sowohl in der geschlossenen als auch geöffneten Position der Tür (6) ergreifen, wobei die seitlichen Schenkel (57) jedes Auf-lagerschuhs beabstandet sind, um eine Leerlaufrolle (58) aufzunehmen, die nach vorne vorsteht und dazwischen an dem vertikalen Abschnitt (48) befestigt ist, wobei die Führungs- und Gleitmittel außerdem ein Paar vertikaler Auf-lagerschuhe (69,70) aufweisen, die in zueinander beabstandeter Anordnung an der Rückfläche des vertikalen Abschnitts (63) befestigt sind, an Positionen, die mit den Positionen der Auf-lagerschuhe (54,55) übereinstimmen, und mit einer Platte (72) versehen sind, die in der vertikalen Richtung bewegbar ist und mit elastischen Mitteln (Feder 78) zusammen wirkt und so geformt ist, dass sie einen nach vorne vorstehenden Ansatz (75) hat, der mit einer schrägen Wand (76) versehen ist, die der zugehörigen vorstehenden Rolle (58) zugewandt ist, wobei die Anordnung derart ist, dass dann, wenn die Tür (6) zu ihrer geöffneten Position verschoben wird, jede vorstehende Rolle (58) durch Einwirkung gegen die zugehörige schräge Wand (76) bewirkt, dass die bewegbaren Platten (72) gegen die Wirkung der elastischen Mittel (78) allmählich nach oben angehoben werden, wodurch es ermöglicht ist, dass der vertikale Abschnitt (27) des Winkelabschnitts (24) der zweiten unteren Halte- und Gleitmittel gegen die zugehörigen vertikalen Auf-lagerschuhe (69,79) verlagert wird und die offene Tür daraufhin relativ zu den Auf-lagerschuhen seitlich gleitet.
5. Vorrichtung nach den Ansprüchen 1, 3 und 4, **dadurch gekennzeichnet, dass** die fünften Führungs- und Synchronisierungsmittel Bewegungsübertragungsmittel (82,90;103,105;109,111) aufweisen, die an dem oberen Endabschnitt und an dem unteren Endabschnitt wenigstens eines vertikalen Abschnitts (28) befestigt sind, der an der Rückwand (9) jeder Zelle (5) befestigt ist und sich über die gesamte Höhe der Zelle (5) erstreckt, und mit den zugehörigen freien hinteren Endabschnitten des oberen transversalen Profilabschnitts (36) der dritten oberen Halte- und Gleitmittel und dem unteren transversalen Profilabschnitt (51) der vierten unteren Halte- und Gleitmittel zusammen wirken, so dass dann, wenn die Tür (6) von der einen in die andere Position der geschlossenen oder geöffneten Position durch Betätigung ihres Handgriffs verschoben wird, die resultierende transversale Versetzung in derselben Richtung der oberen und unteren transversalen Pro-

filabschnitte (36, 51) auf eine syn-chronisierte Weise durch die Bewegungsübertragungsmittel (82,90, 103,105; 109,111) erfolgt.

6. Vorrichtung nach Anspruch 5, **dadurch gekennzeichnet, dass** die Bewegungsübertragungsmittel eine erste obere um eine horizontale Achse drehbare zylindrische Rolle (82) aufweisen, die drehbar an dem oberen Endabschnitt des vertikalen Profilabschnitts (28) angebracht ist und koaxial mit dem oberen transversalen Profilabschnitt (36) der dritten oberen Halte- und Gleitmittel ausgerichtet und mit einer oberen drehenden Seilscheibe (86) verbunden ist, und ferner eine zweite untere um eine horizontale Achse drehende zylindrische Rolle (90) aufweisen, die drehbar an dem unteren Endabschnitt des vertikalen Profilabschnitts (28) angebracht und koaxial auf den unteren transversalen Profilabschnitt (51) der vierten unteren Halte- und Gleitmittel ausgerichtet ist und mit einer unteren drehenden Seilscheibe (94) verbunden ist, die mit der oberen drehenden Seilscheibe (86) über eine Stahlschnur (97), einen Zahnriemen (98), ein Band (100) oder dergleichen verbunden ist und **dadurch gekennzeichnet, dass** jede der ersten und zweiten zylindrischen Rollen (82,90) so geformt ist, dass sie eine Doppelstartschraubennut (87,95) enthält, die sich entlang ihres Umfangs erstreckt, wobei die Nut in Eingriff mit geradlinigen transversalen Stiften (88,89) der oberen und unteren transversalen Profilabschnitte (36,51) steht.
7. Vorrichtung nach Anspruch 5, **dadurch gekennzeichnet, dass** die Bewegungsübertragungsmittel ein Paar oberer um horizontale Achsen drehende Seilscheiben (103) und eine um eine vertikale Achse drehende Ablenkungsseilscheibe (105) aufweisen, die drehbar an dem oberen Endabschnitt des vertikalen Profilabschnitts (28) angebracht sind, und ein Paar unterer um horizontale Achsen drehende Seilscheiben (108) und eine um eine vertikale Achse drehende Ablenkungsseilscheibe (111), die drehbar an dem unterem Endabschnitt des vertikalen Profilabschnitts (28) angebracht sind und miteinander über eine Stahlschnur (87) oder dergleichen verbunden sind, die den oberen transversalen Profilabschnitt (36) und den unteren transversalen Profilabschnitt (51) jeweils mit der Hilfe einer Schraube (107) oder dergleichen ergreift.
8. Vorrichtung nach jedem der vorhergehenden Ansprüche, **dadurch gekennzeichnet, dass** der Profilabschnitt (16) der ersten oberen Halte- und Gleitmittel mit einer Folge von Durchgangsöffnungen (114) versehen ist, die über die gesamte Länge des Profilabschnitts gleichmäßig voneinander beabstandet sind, um die vorderen Räder (45) des Winkelabschnitts (21) der ersten oberen Halte- und Gleit-

mittel dort aufzunehmen, sowie um die vorderen Räder (32) der oberen Schiene (29) dort aufzunehmen, wenn die Tür (6) sich in dem offenen Zustand befindet, und die Räder (32) sich in eine Anordnung bewegen, in der sie longitudinal auf die Räder (45) ausgerichtet sind, und

dadurch gekennzeichnet, dass der Profilabschnitt (19) der ersten oberen Halte- und Gleitmittel in dem unteren Abschnitt so geformt ist, dass er eine Folge halbkreisförmigen Ausnehmungen (117) aufweist, die alle entlang einer Vorderseite des Profilabschnitts vorgesehen und regelmäßig voneinander beabstandet sind mit einer Mitte-zu-Mitte Distanz zwischen ihnen, auf die gleich derjenigen zwischen den Rädern (45) ist, um in der Lage zu sein, auf die Vorderräder (45) zu passen, wenn die Tür in ihre geschlossene Position verschoben ist.

20 Revendications

1. Dispositif de support et d'actionnement pour portes coulissantes (6) d'armoires (5), dans lequel chaque armoire (5) comprend une face avant plane (6), une paroi arrière (9), un plafond supérieur plan (10), un fond inférieur plan (11) et deux parois latérales (12, 13) et chaque porte (6) est dotée de poignées (7, 8) pour son déplacement d'une position fermée dans laquelle elle est légèrement rentrée dans le sens de la profondeur de l'armoire (5) par rapport à sa face avant, à une position ouverte, dans laquelle elle est tout d'abord déplacée vers l'avant sur une étendue limitée dans le sens de la profondeur de l'armoire (5) par rapport à sa face avant, et est ensuite amenée à coulisser de manière rectiligne latéralement dans la position souhaitée dans un agencement parallèle par rapport à la face avant de l'armoire (5) et revient ensuite dans sa position bloquée grâce à une série inverse des mouvements décrits ci-dessus, comprenant des premiers moyens de support et de coulissement (16, 19, 21) de la partie supérieure de la porte (6), qui sont adaptés pour supporter ladite partie de porte supérieure dans l'armoire (5) lorsque la porte (6) est déplacée dans sa position fermée ou ouverte, et qui sont en outre adaptés pour guider le mouvement coulissant longitudinal alterné de ladite partie de porte supérieure dans l'armoire (5) lorsque la porte (6) est déplacée dans sa position ouverte ; des deuxièmes moyens de support et de coulissement inférieurs (24) de la partie inférieure de la porte (6), qui sont adaptés pour supporter ladite partie de porte inférieure dans l'armoire (5) lorsque la porte (6) est déplacée dans sa position fermée ou ouverte, et qui sont en outre adaptés pour guider le mouvement coulissant longitudinal alterné de ladite partie de porte inférieure dans l'armoire (5), lorsque la porte (6) est déplacée dans sa position ouverte ; des troisièmes moyens de support et de coulissement (29,

36) de la partie supérieure de la porte (6) qui, à l'usage, sont appliqués sur le plafond supérieur (10) de l'armoire (5) et adaptés pour supporter ladite partie de porte supérieure dans l'armoire (5), lorsque la porte (6) est déplacée dans sa position fermée ou ouverte et qui sont en outre adaptés pour déterminer le mouvement coulissant de la porte (6) transversalement dans le sens de la profondeur de l'armoire (5) vers et depuis sa position fermée et ouverte, et en outre adaptés pour déterminer le mouvement coulissant longitudinal alterné de ladite partie de porte supérieure dans l'armoire (5) lorsque la porte (6) est déplacée dans sa position ouverte ; des quatrièmes moyens de support et de coulissement inférieurs (46, 51) de la partie inférieure de la porte (6) qui sont, à l'usage, appliqués sur le fond (11) de l'armoire (5) et adaptés pour supporter ladite partie de porte inférieure dans l'armoire (5) lorsque la porte (6) est déplacée dans sa position fermée ou ouverte, et qui sont en outre adaptés pour déterminer le mouvement coulissant de la porte (6) transversalement dans le sens de la profondeur de l'armoire (5) vers et depuis ladite position fermée et ouverte, et en outre adaptés pour déterminer le mouvement coulissant longitudinal alterné de ladite partie de porte inférieure dans l'armoire (5) lorsque la porte (6) est déplacée dans sa position ouverte ; et comprenant des cinquièmes moyens de synchronisme (28 ; 82, 90, ; 103, 105 ; 109, 111) coopérant avec lesdits troisièmes moyens de support et de coulissement supérieurs (29, 36) et lesdits quatrièmes moyens de support et de coulissement inférieurs (46, 51) pour permettre à ladite partie supérieure et ladite partie inférieure de la porte, respectivement, de coulisser d'une manière synchronisée transversalement dans le sens de la profondeur de l'armoire (5) vers et depuis lesdites positions fermée et ouverte de cette même porte, **caractérisé en ce que** lesdits premiers moyens de support et de coulissement supérieurs comprennent une section de profil métallique (16) configurée pour comprendre une partie plane rectiligne verticale (17) qui, à l'usage, est fixée sur la partie supérieure de chaque porte (6) et fléchie vers l'intérieur, vers l'intérieur de l'armoire et qui supporte au niveau de sa partie d'extrémité, une section de profil rectiligne verticale supplémentaire (19), qui est formée de sorte qu'elle comprend une rainure inférieure (20) formée à l'intérieur de cette dernière et s'étendant sur toute sa longueur et comprend en outre une section angulaire (21) dans une forme rectiligne allongée, qui est configurée pour comprendre une partie horizontale (22) qui, à l'usage, est fixée sur le plafond supérieur (10) de l'armoire, et une partie verticale courte (23) orientée vers le haut, dans laquelle on trouve une série de roues de guidage (45) articulées de manière rotative, similaires à et régulièrement espacées les unes des autres, qui sont prévues dans un agencement mutuellement ali-

gné le long de ladite partie verticale (23), et **caractérisé en ce que** lesdits troisièmes moyens de support et de coulissement supérieurs comprennent un patin supérieur (29) composé d'une section de profil métallique rectiligne (30) et d'une section de profil transversale rectiligne centrale (36) assemblée transversalement à ladite section de profil allongée (30), au niveau de sa partie arrière, afin de former une structure en forme de T avec cette dernière, et s'étendant sur toute la profondeur de chaque armoire (5), ladite section de profil allongée (30) étant prévue avec une série de roues intermédiaires avant (32) librement rotatives similaires à, régulièrement espacées et alignées les unes par rapport aux autres le long de la même section de profil (30), ainsi que des roues latérales intermédiaires (33) librement rotatives et des roues inférieures (34), ladite section de profil allongée (30) étant fixée sur ladite partie de section de profil horizontale (22) desdits premiers moyens de support et de coulissement supérieurs, qui est également mise en prise par lesdites roues latérales (33) et les roues inférieures (34), afin de garantir que lesdites roues intermédiaires avant (32) mettent en prise de manière constante ladite rainure inférieure (20) de ladite section de profil rectiligne verticale (19) desdits premiers moyens de support et de coulissement supérieurs, dans la position fermée ou ouverte de ladite porte (6), ladite section de profil allongée (30) étant déplaçable dans la direction transversale de l'armoire (5) conjointement avec ladite section de profil transversale (36) et la partie supérieure de ladite porte (6) de sorte que, dans la position ouverte de ladite porte (6), également lesdites roues de guidage (45) de ladite section angulaire (21) mettent en prise ladite rainure inférieure (20) de ladite section de profil rectiligne verticale (19) et la porte (6) peut coulisser latéralement dans la position d'ouverture souhaitée, le mouvement coulissant relatif étant guidé par le plan de guidage formé avec ces roues de guidage (45).

2. Dispositif selon la revendication 1, **caractérisé en ce que** lesdits deuxièmes moyens de support et de coulissement inférieurs comprennent une section angulaire (24) réalisée avec un métal ou un matériau thermoplastique, ayant une extension horizontale rectiligne, et formée afin de comprendre une partie horizontale courte (25) qui, à l'usage, est assemblée à la partie inférieure de chaque porte (6) au moyen de consoles (26) et qui est pliée vers le haut afin de former une partie verticale courte (27).
3. Dispositif selon la revendication 2, **caractérisé en ce que** lesdits quatrièmes moyens de support et de coulissement inférieurs comprennent un patin inférieur (46) composé d'une section angulaire métallique allongée (47), et d'une section de profil transversale rectiligne centrale (51) assemblée transver-

salement à ladite section angulaire allongée (47), au niveau de sa partie arrière, afin de former une structure en forme de T avec cette dernière, et s'étendant sur toute la profondeur de chaque armoire (5), ladite section angulaire allongée (47) étant formée afin de comprendre une partie verticale plane (48) qui est pliée afin de former une partie plane supérieure horizontale courte (49) et étant en outre prévue dans sa région centrale avec des roues intermédiaires inférieures (50) articulées d'une manière librement rotative avec cette dernière, ladite section angulaire allongée (47) s'assemblant avec une section angulaire (61) ci-dessus, qui est formée à son tour afin de comprendre une partie plane horizontale (62) et une partie plane verticale et avant (63), et est fixée sous le fond (11) de l'armoire (5), lesdites parties verticales (48, 63) des sections angulaires (47, 61) respectives étant prévues avec des moyens de guidage et de coulisement (54 ; 55 ; 69, 70) qui coopèrent entre eux et sont adaptés pour supporter la section angulaire (24) desdits deuxièmes moyens de support et de coulisement inférieurs dans la position fermée ou ouverte de ladite porte (6), et sont en outre adaptés pour guider ladite porte (6) dans son mouvement longitudinal alterné dans sa position ouverte.

4. Dispositif selon la revendication 3, **caractérisé en ce que** lesdits moyens de guidage et de coulisement des quatrièmes moyens de support et de coulisement inférieurs, comprennent une paire de sabots (54, 55) fixés selon un agencement mutuellement espacés contre une surface avant de ladite partie verticale (48) de ladite section angulaire (47) et formés afin de comprendre des tiges latérales (57) faisant saillie vers l'avant et mettant en prise la partie verticale (27) de ladite section angulaire (24) des deuxièmes moyens de support et de coulisement inférieurs, à la fois dans lesdites positions fermée et ouverte de la porte (6), les tiges latérales (57) de chacun de ces sabots étant espacées pour loger un galet fou (58) faisant saillie vers l'avant et fixé sur ladite partie verticale (48), entre elles, lesdits moyens de guidage et de coulisement comprenant en outre une paire de sabots verticaux (69, 70) fixés selon un agencement mutuellement espacés contre la surface arrière de ladite partie verticale (63), dans des positions qui coïncident avec les positions desdits sabots (54, 55), et prévus avec une plaque (72) qui est mobile dans la direction verticale et coopèrent avec des moyens élastiques (ressort 78), formés également afin de comprendre une partie en saillie avant (75) prévue avec une paroi inclinée (76) faisant face au rouleau en saillie (58) correspondant, l'agencement étant tel que, lorsque la porte (6) est déplacée vers sa position ouverte, chaque rouleau en saillie (58), en agissant contre ladite paroi inclinée (76) respective, amène lesdites plaques mobiles

(72) à être progressivement levées vers le haut contre l'action desdits moyens élastiques (78), permettant ainsi à ladite partie verticale (27) de ladite section angulaire (24) des deuxièmes moyens de support et de coulisement inférieurs, de se déplacer contre les sabots verticaux (69, 70) relatifs et la porte ouverte pour coulisser ensuite latéralement par rapport à ces mêmes sabots.

5. Dispositif selon les revendications 1, 3 et 4, **caractérisé en ce que** lesdits cinquièmes moyens de guidage et de synchronisme comprennent des moyens de transmission de mouvement (82, 90 ; 103, 105 ; 109, 111) fixés sur la partie d'extrémité supérieure et la partie d'extrémité inférieure d'au moins une section verticale (28), qui est fixée sur la paroi arrière (9) de chaque armoire (5) et s'étend sur toute la hauteur de cette même armoire (5) et coopérant avec les parties d'extrémité arrière libres respectives des sections de profil transversales supérieures (36) des troisièmes moyens de support et de coulisement supérieurs et ladite section de profil transversale inférieure (51) des quatrièmes moyens de support et de coulisement inférieurs de sorte que, lorsque ladite porte (6) est déplacée de l'une à l'autre de ses positions fermée et ouverte en l'actionnant par le biais de sa poignée, le déplacement transversal résultant dans la même direction desdites sections de profil transversales supérieure et inférieure (36, 51) se produit d'une manière synchronisée par lesdits moyens de transmission de mouvement (82, 90 ; 103, 105 ; 109, 111).
6. Dispositif selon la revendication 5, **caractérisé en ce que** lesdits moyens de transmission de mouvement comprennent un premier rouleau cylindrique rotatif supérieur d'axe horizontal (82) articulé de manière rotative sur la partie d'extrémité supérieure de ladite section de profil verticale (28) et aligné de manière coaxiale avec ladite section de profil transversale supérieure (36) desdits troisièmes moyens de support et de coulisement supérieurs assemblés avec une poulie rotative supérieure (86), et comprennent en outre un deuxième rouleau cylindrique rotatif inférieur d'axe horizontal (90) articulé de manière rotative sur la partie d'extrémité supérieure de ladite section de profil vertical (28) et aligné de manière coaxiale avec ladite section de profil transversale inférieure (51) desdits quatrièmes moyens de support et de coulisement inférieur, également assemblé avec une poulie rotative inférieure (94) qui est raccordée avec ladite poulie rotative supérieure (86) via un câble en acier (97), une courroie synchrone (98), une sangle (100) ou similaire, et **caractérisé en ce que** l'un desdits premier et deuxième rouleaux cylindriques (82, 90) est formé afin de comprendre une rainure hélicoïdale à double pas (87, 95) s'étendant tout le long de sa surface périphérique, ladite

rainure mettant en prise des broches transversales rectilignes (88, 89) desdites sections de profil transversales supérieure et inférieure (36, 51).

7. Dispositif selon la revendication 5, **caractérisé en ce que** lesdits moyens de transmission de mouvement comprennent une paire de poulies rotatives supérieures d'axe horizontal (103) et une poulie de déviation rotative d'axe vertical (105) qui sont articulées de manière rotative sur la partie d'extrémité supérieure de ladite section de profil verticale (28), et une paire de poulies rotatives inférieures d'axe horizontal (108) et une poulie de déviation de rotation d'axe vertical (111) qui sont articulées de manière rotative sur la partie d'extrémité inférieure de ladite section de profil verticale (28) et sont assemblées entre elles via un câble en acier (97) ou similaire, mettant en prise ladite section de profil transversale supérieure (36) et ladite section de profil transversale inférieure (51) respectivement, à l'aide d'un boulon (107) ou similaire.
8. Dispositif selon l'une quelconque des revendications précédentes, **caractérisé en ce que** la section de profil (16) des premiers moyens de support et de coulissement supérieurs est prévue avec une série d'ouvertures de passage (114), espacées régulièrement les unes des autres sur toute la longueur de la même section de profil, pour lesdites roues avant (45) de la section angulaire (21) desdits premiers moyens de support et de coulissement supérieurs destinés à être reçues et logées à cet endroit, ainsi que pour les roues avant (32) dudit patin supérieur (29) destinées à être reçues et logées à cet endroit, lorsque ladite porte (6) est dans sa condition ouverte et lesdites roues (32) se déplacent selon un agencement dans lequel elles sont alignées longitudinalement avec lesdites roues (45), et **caractérisé en ce que** ladite section de profil (19) desdits premiers moyens de support et de coulissement est formée dans sa partie inférieure afin de comprendre une série d'évidements semi-circulaires (117) prévus tout le long d'une face avant de la même section de profil et régulièrement espacés les uns des autres avec une distance de centre à centre entre eux qui est égale à la distance entre lesdites roues (45) afin de pouvoir s'adapter sur lesdites roues avant (45) lorsque la porte (6) est déplacée dans sa position fermée.

50

55

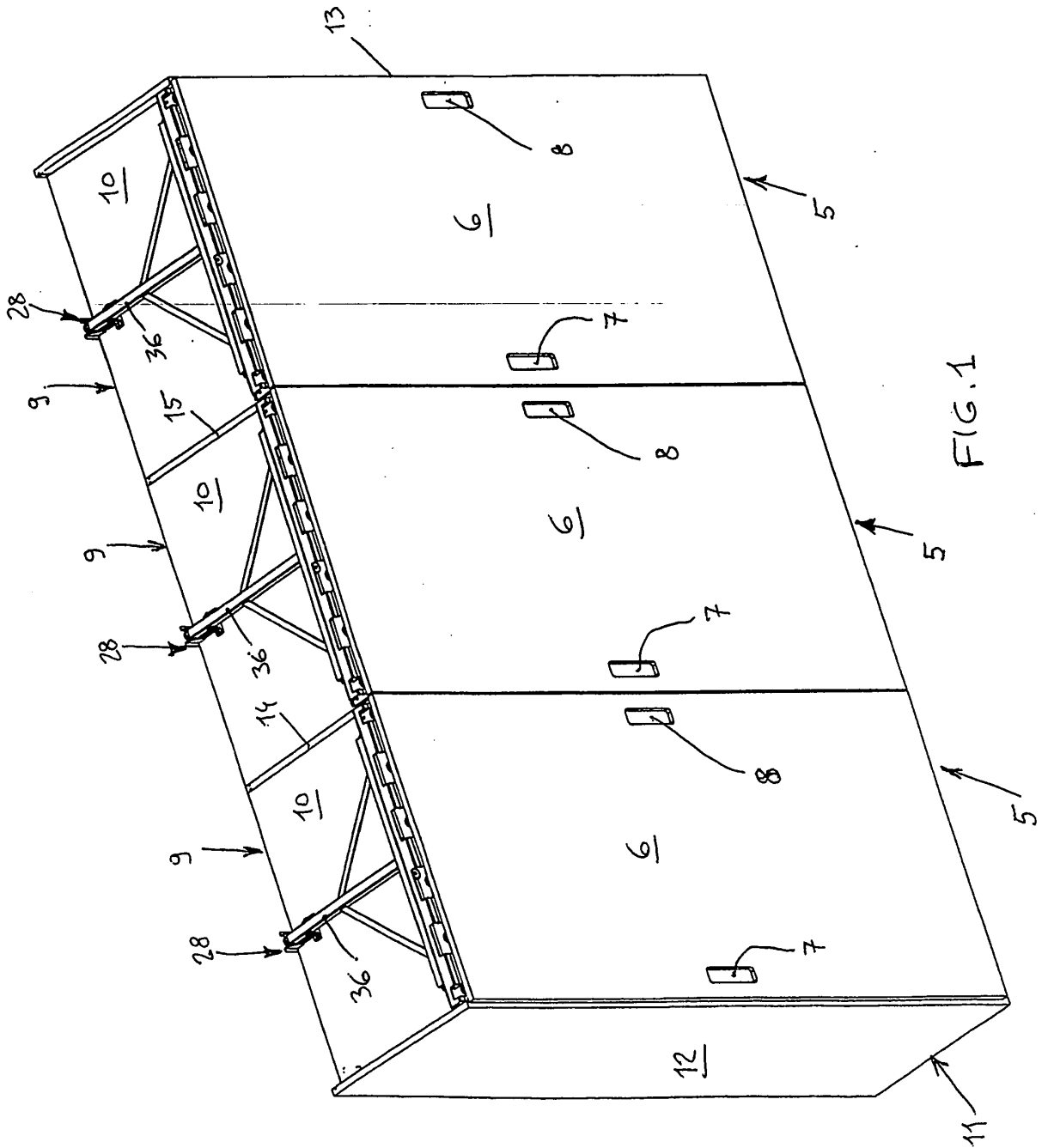

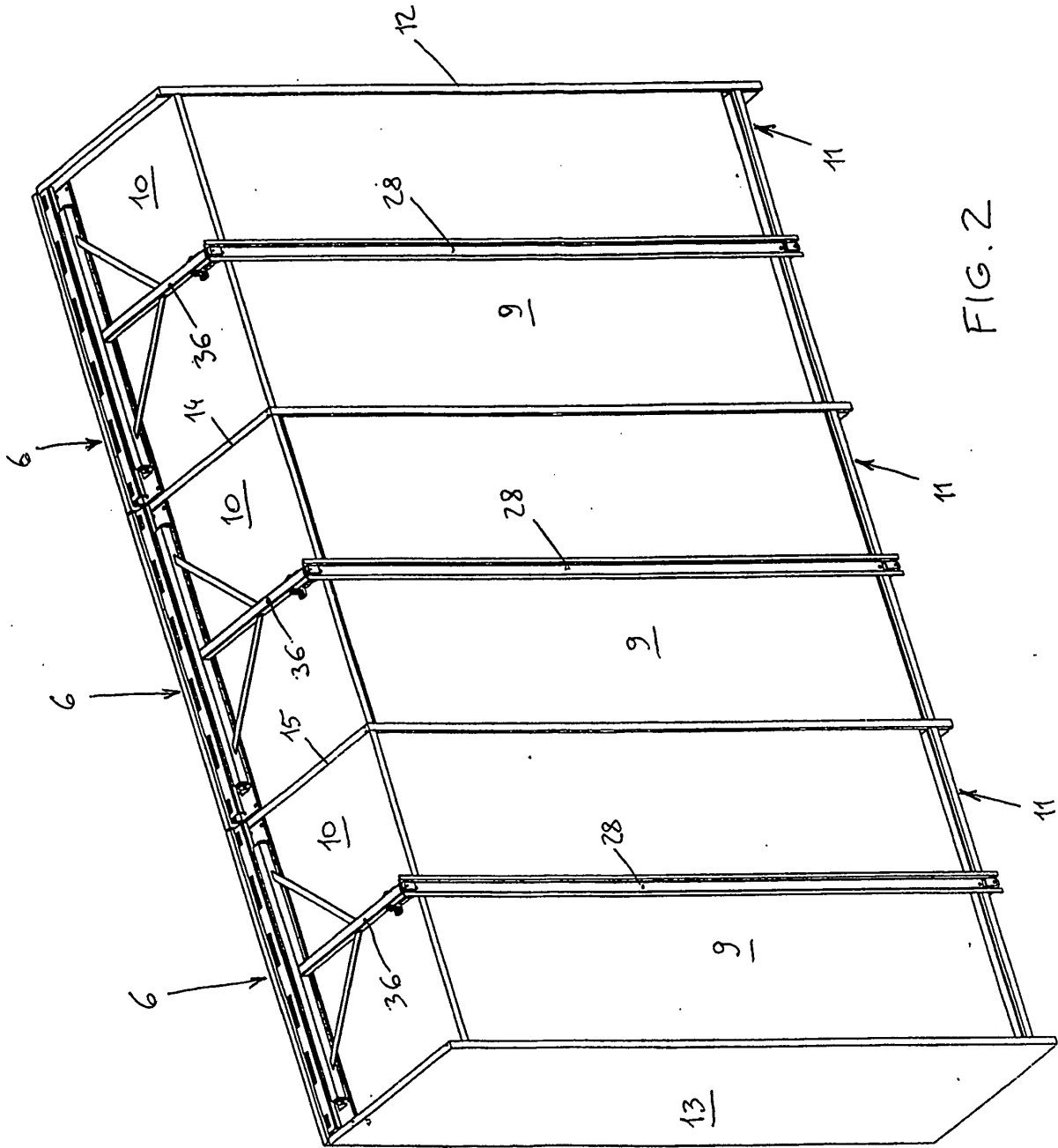

FIG. 2

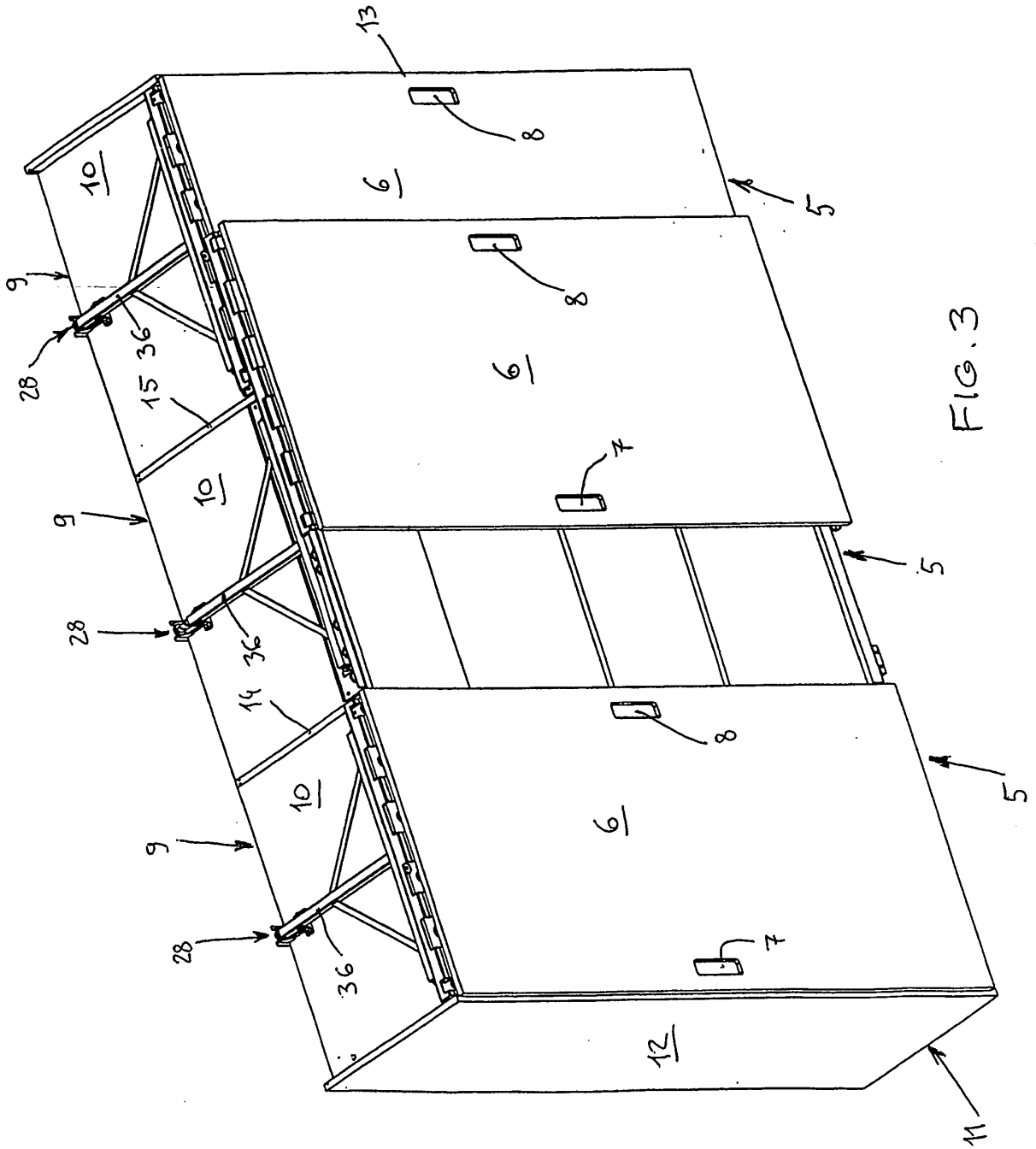

FIG. 3

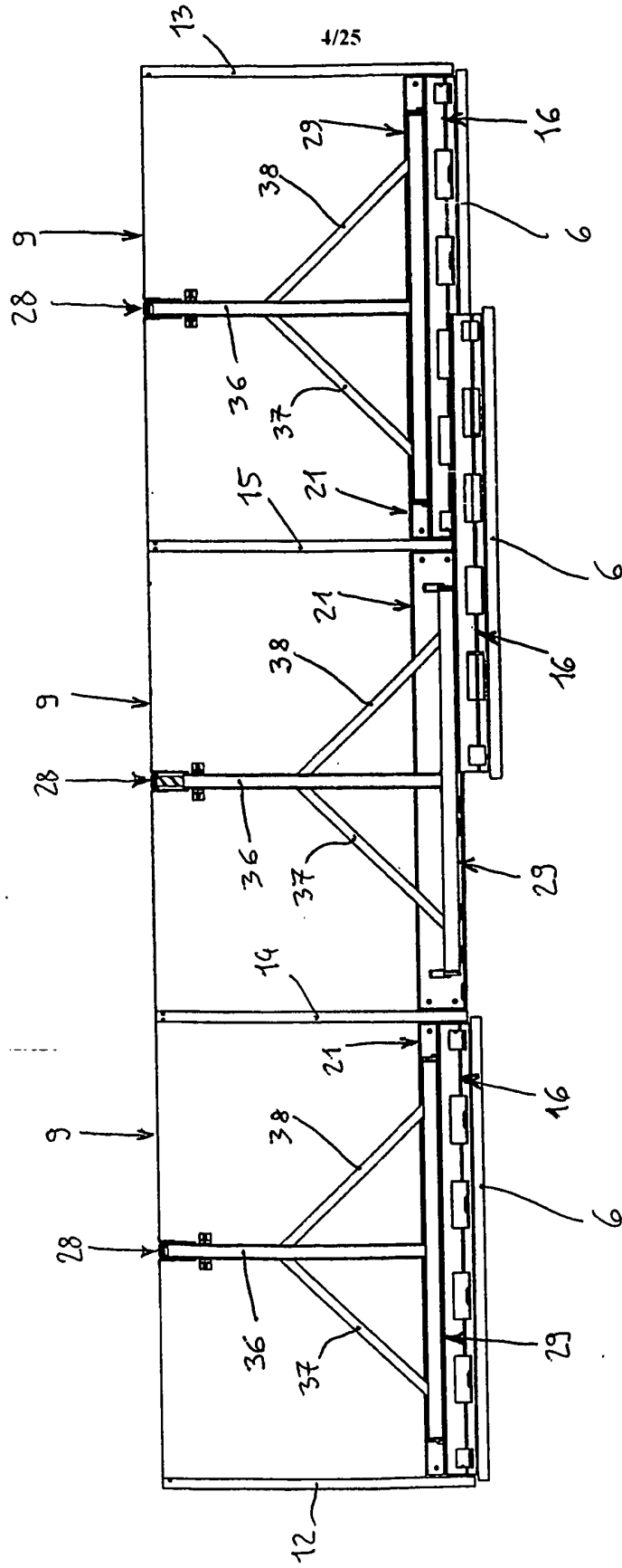

FIG. 4

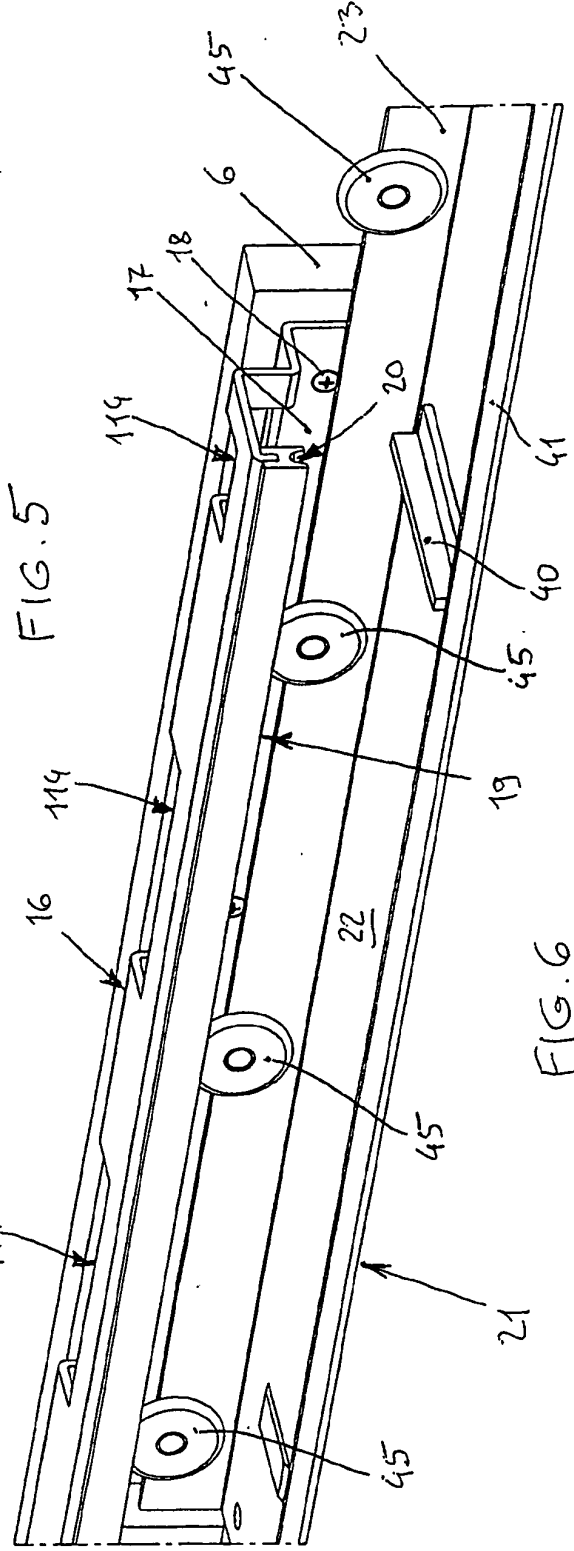
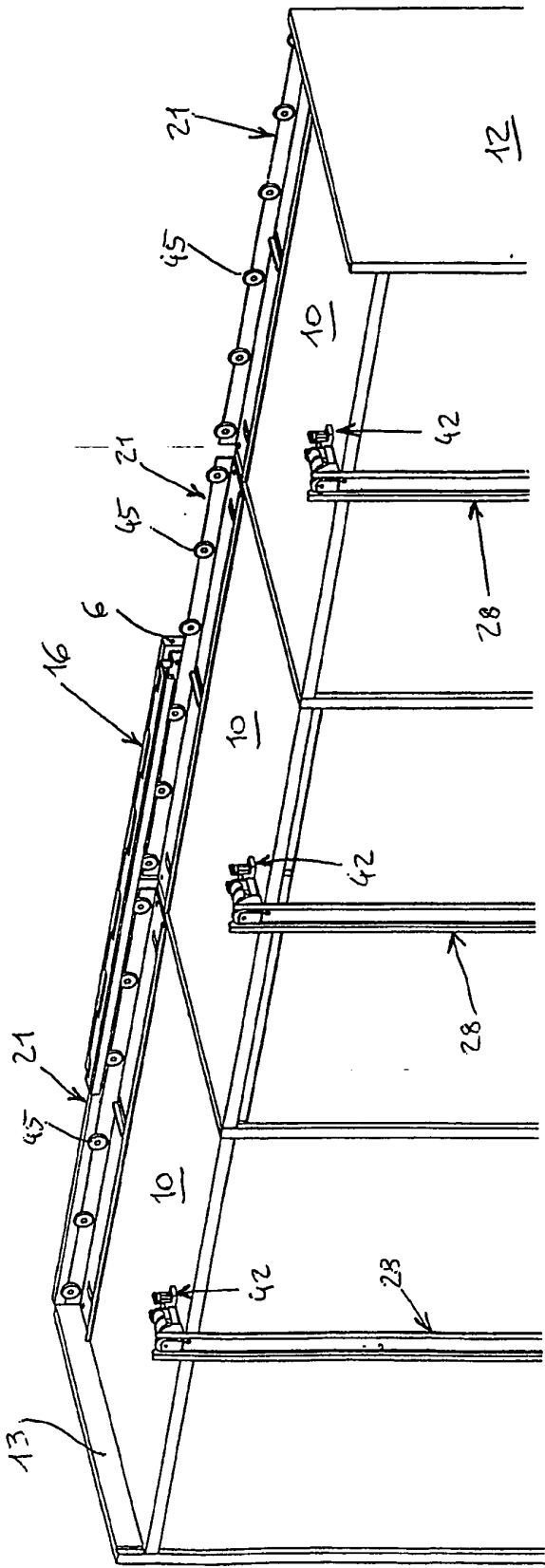
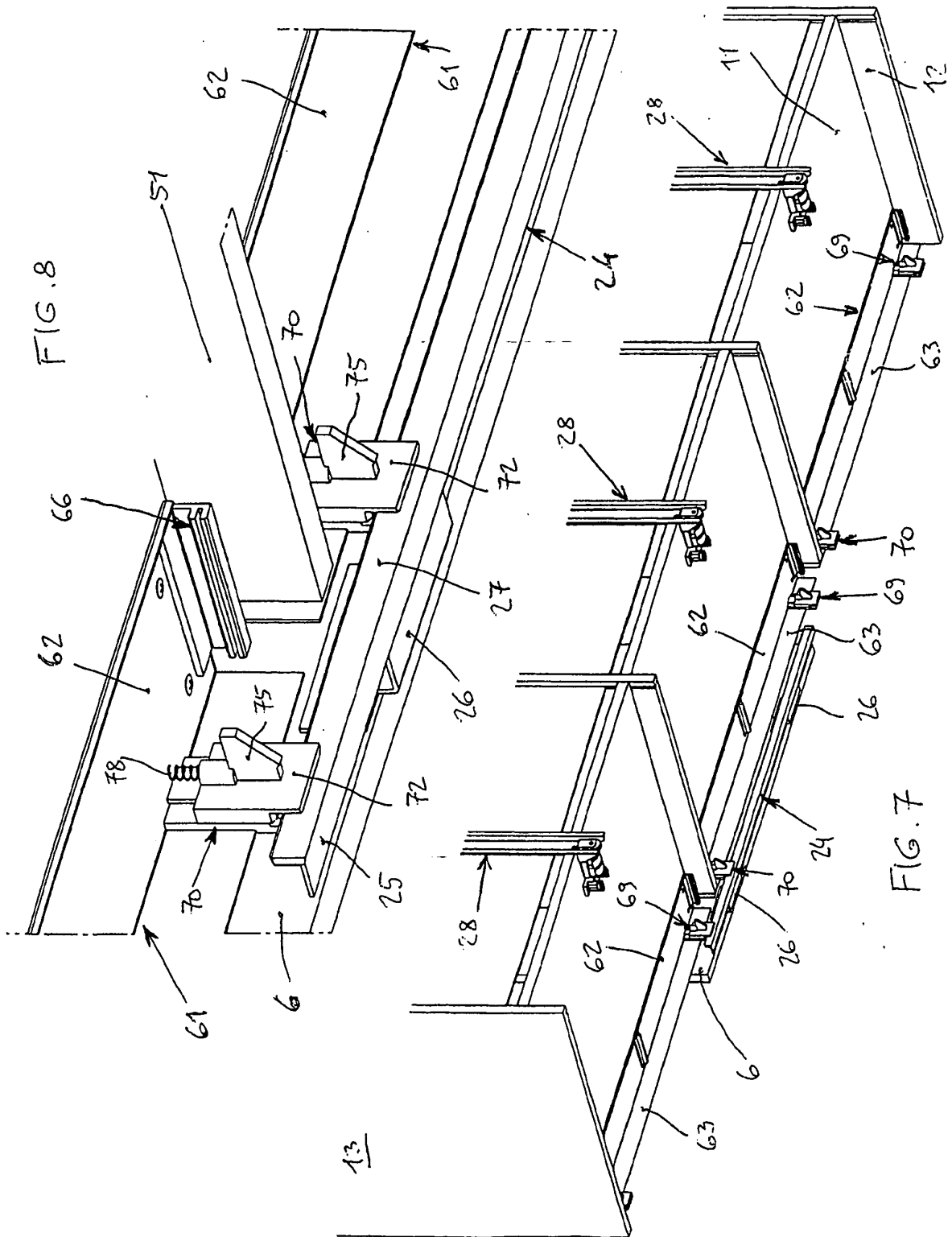

FIG. 5

FIG. 6



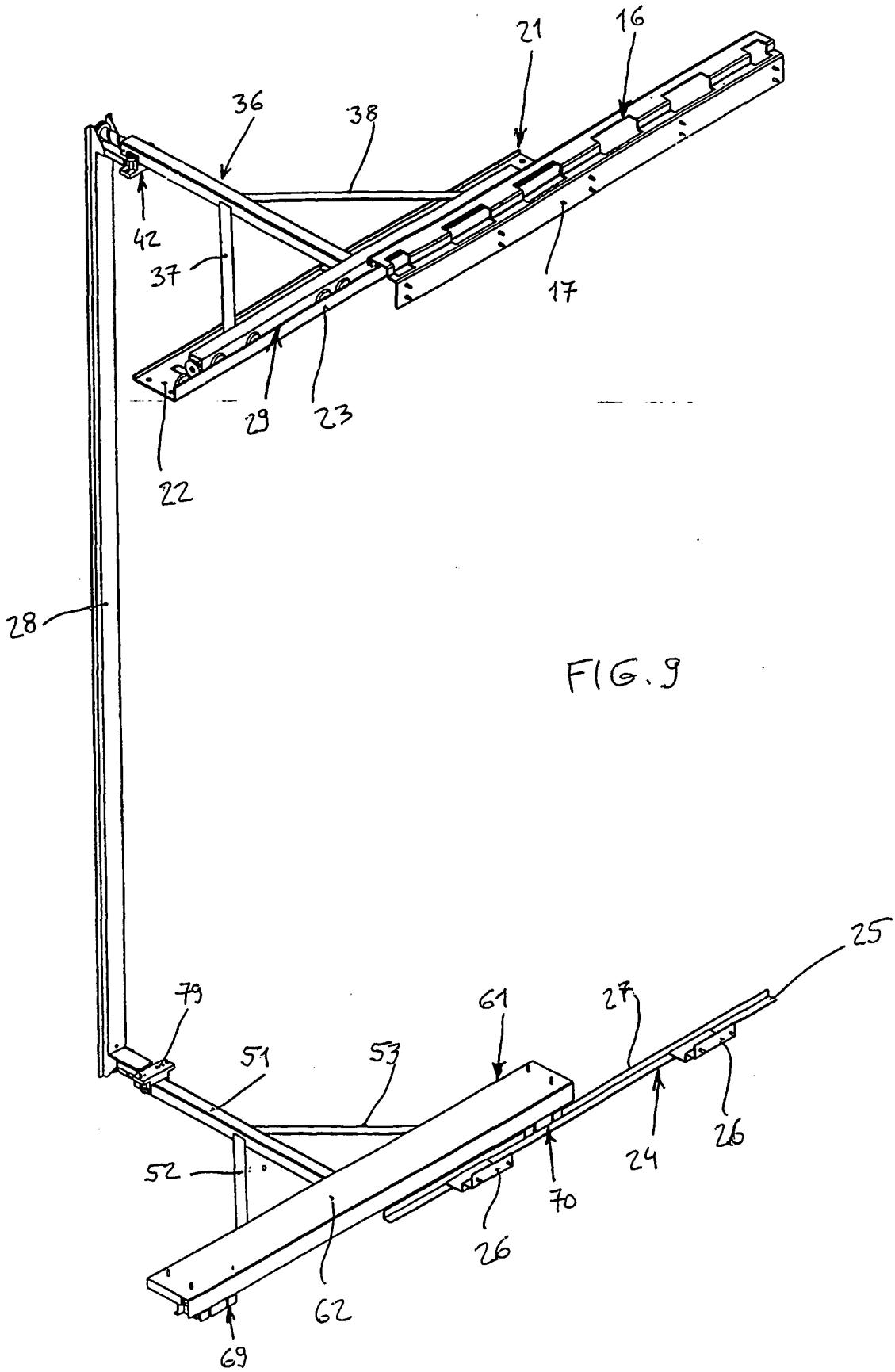
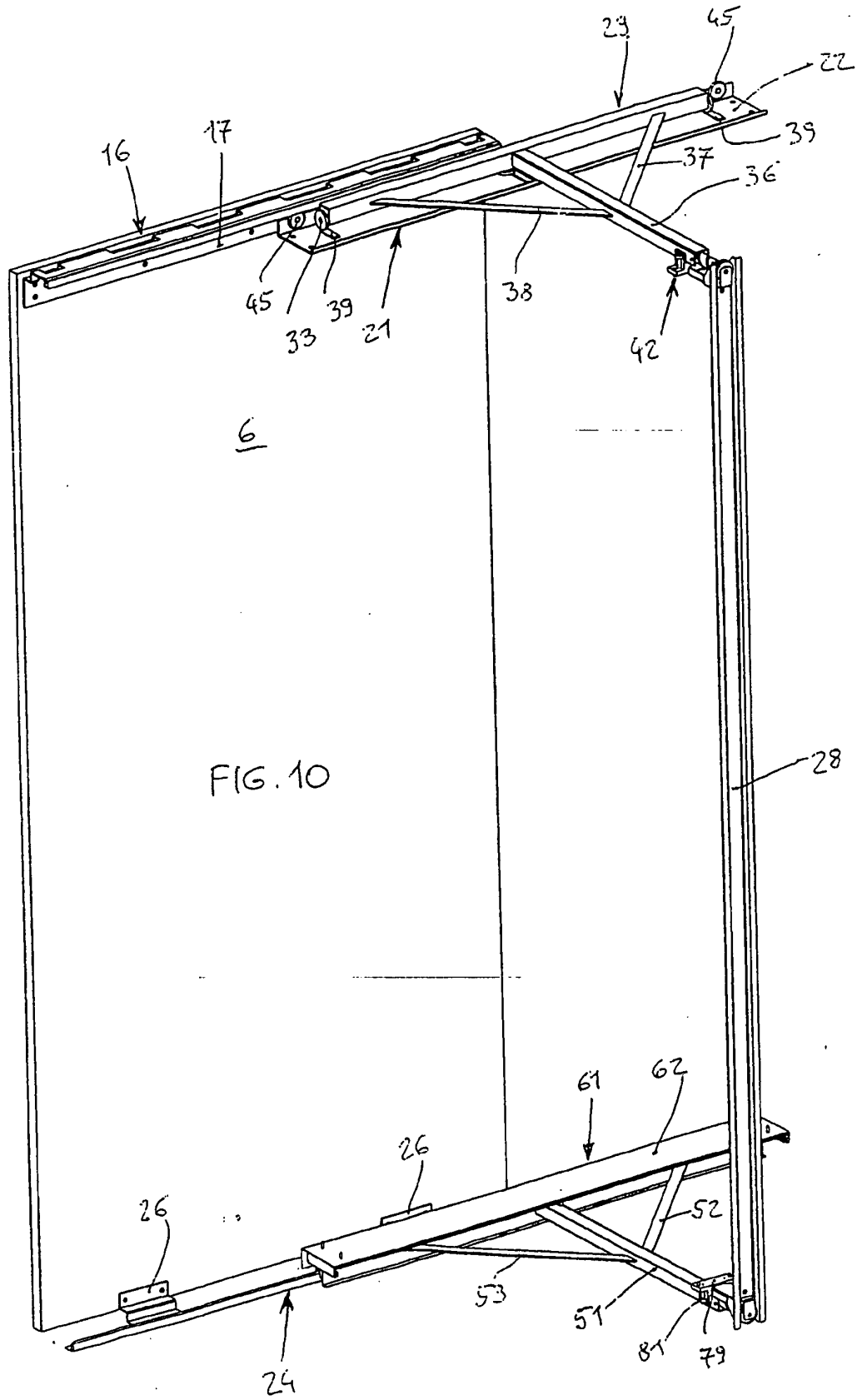
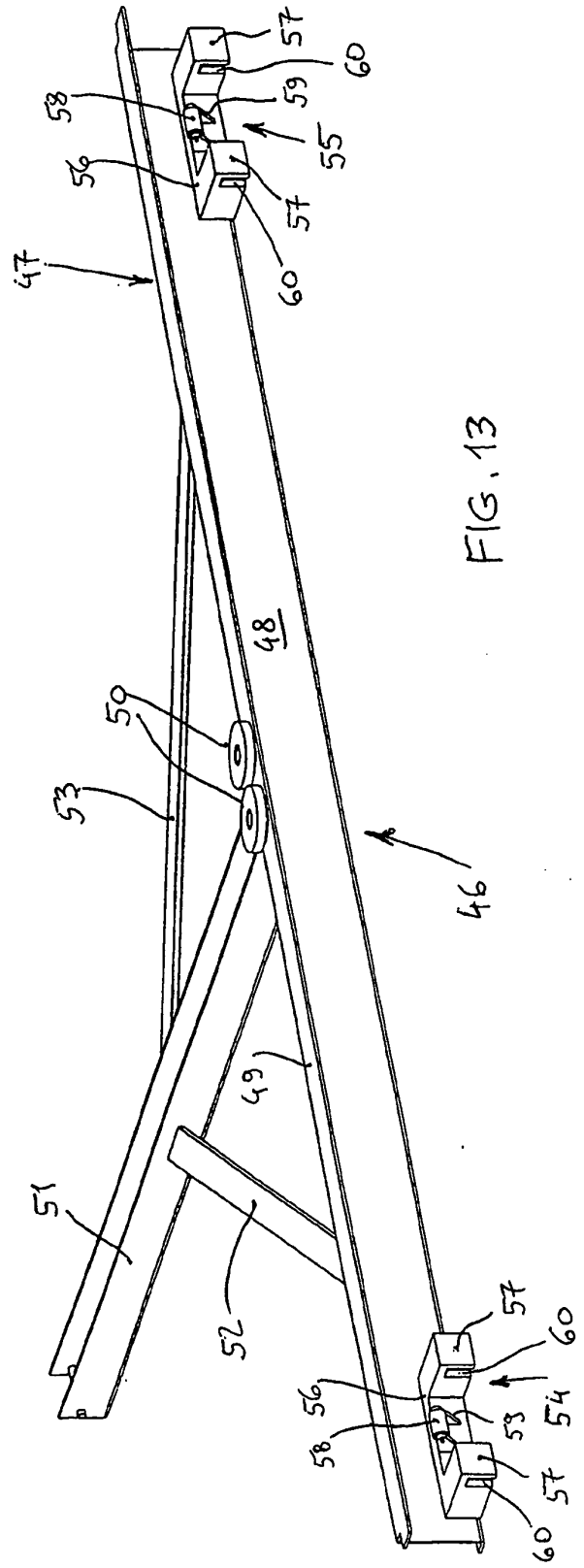
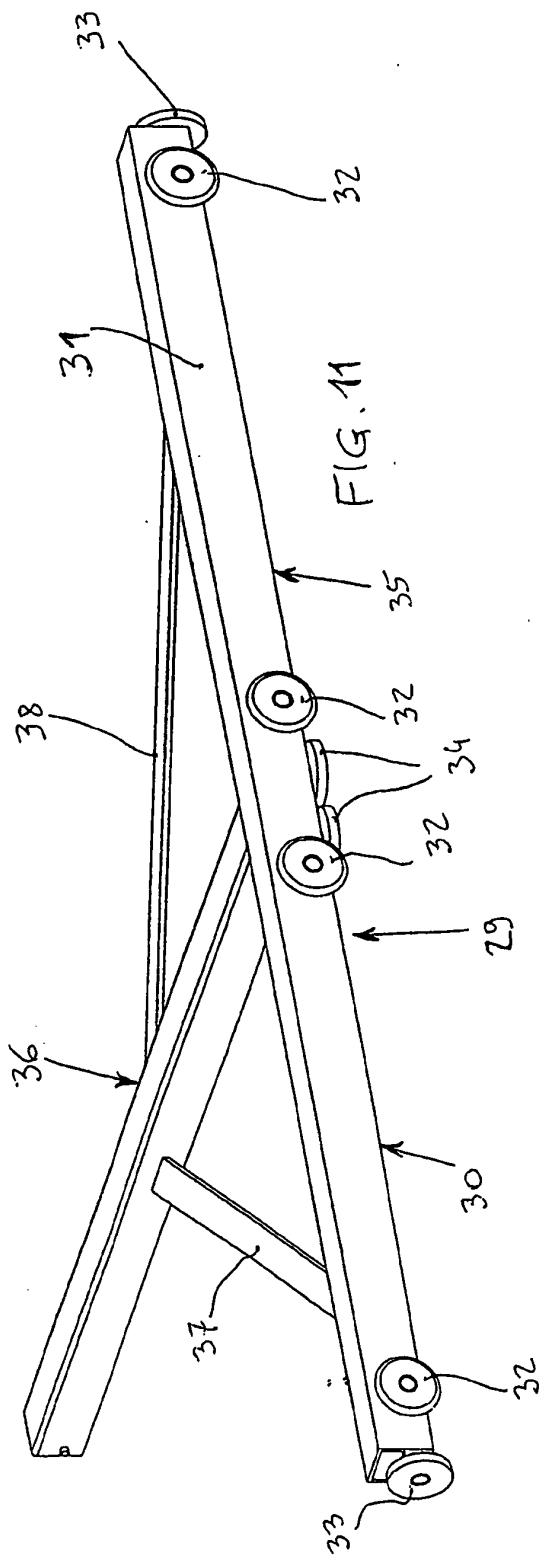

FIG. 9





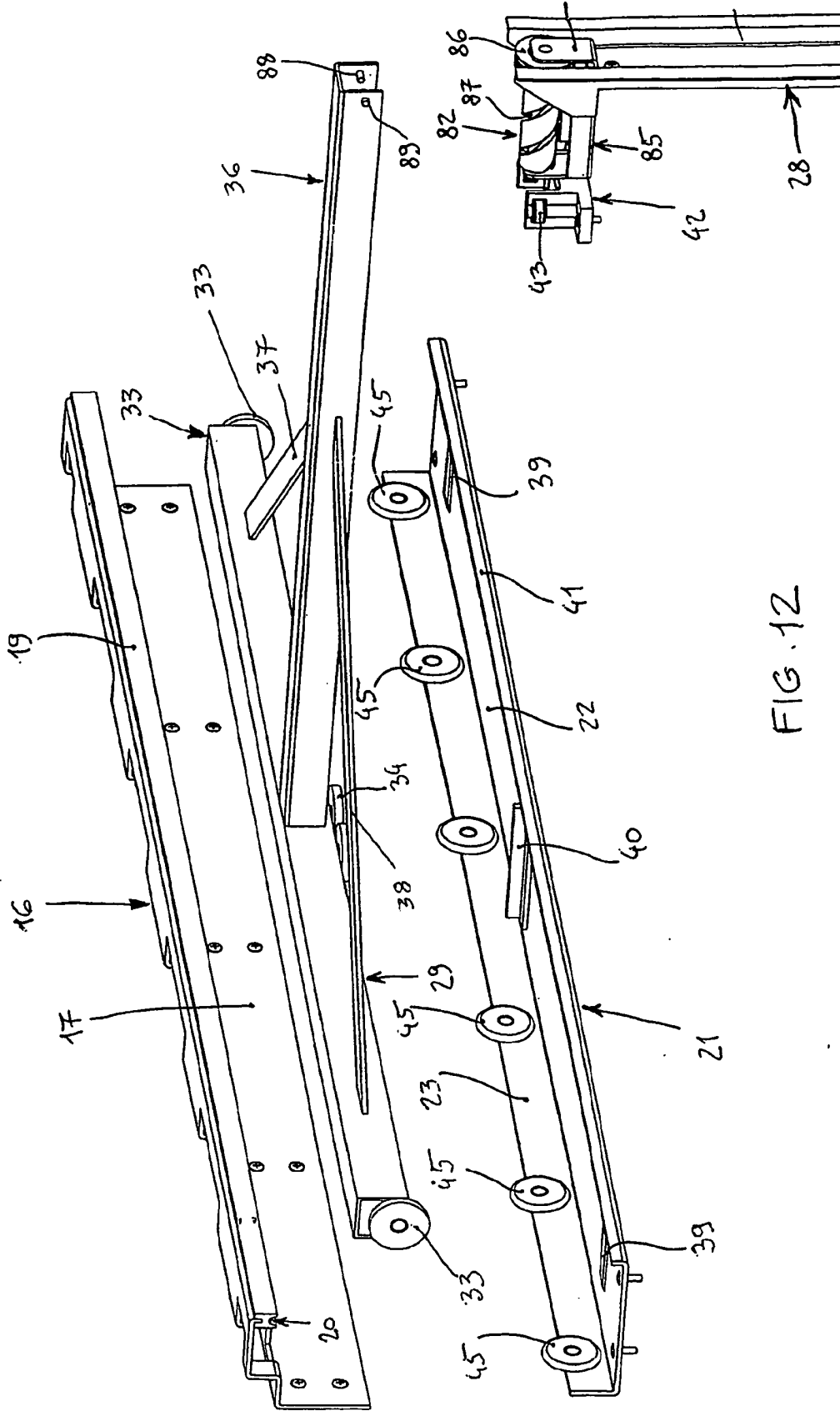
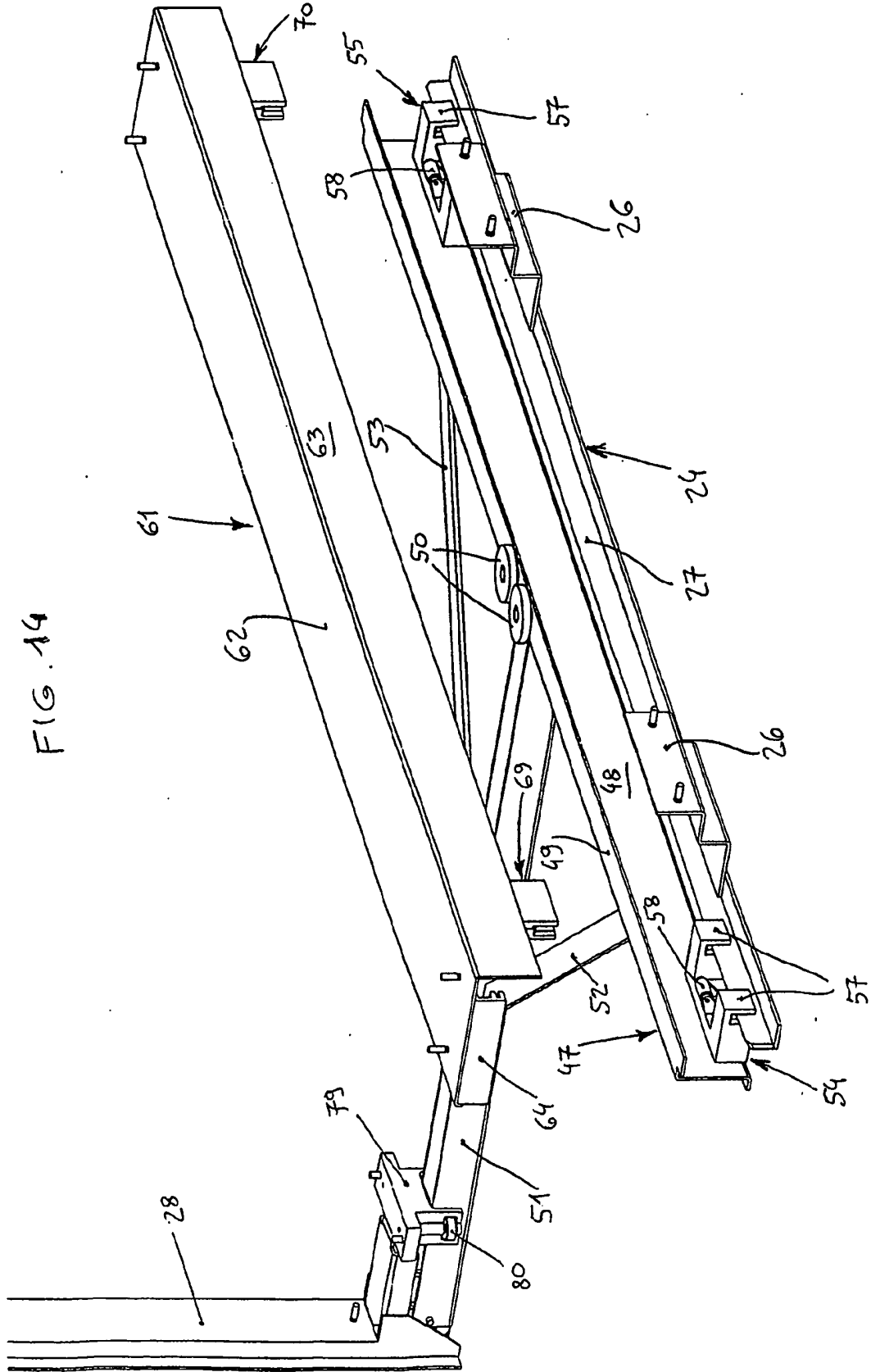

FIG. 12



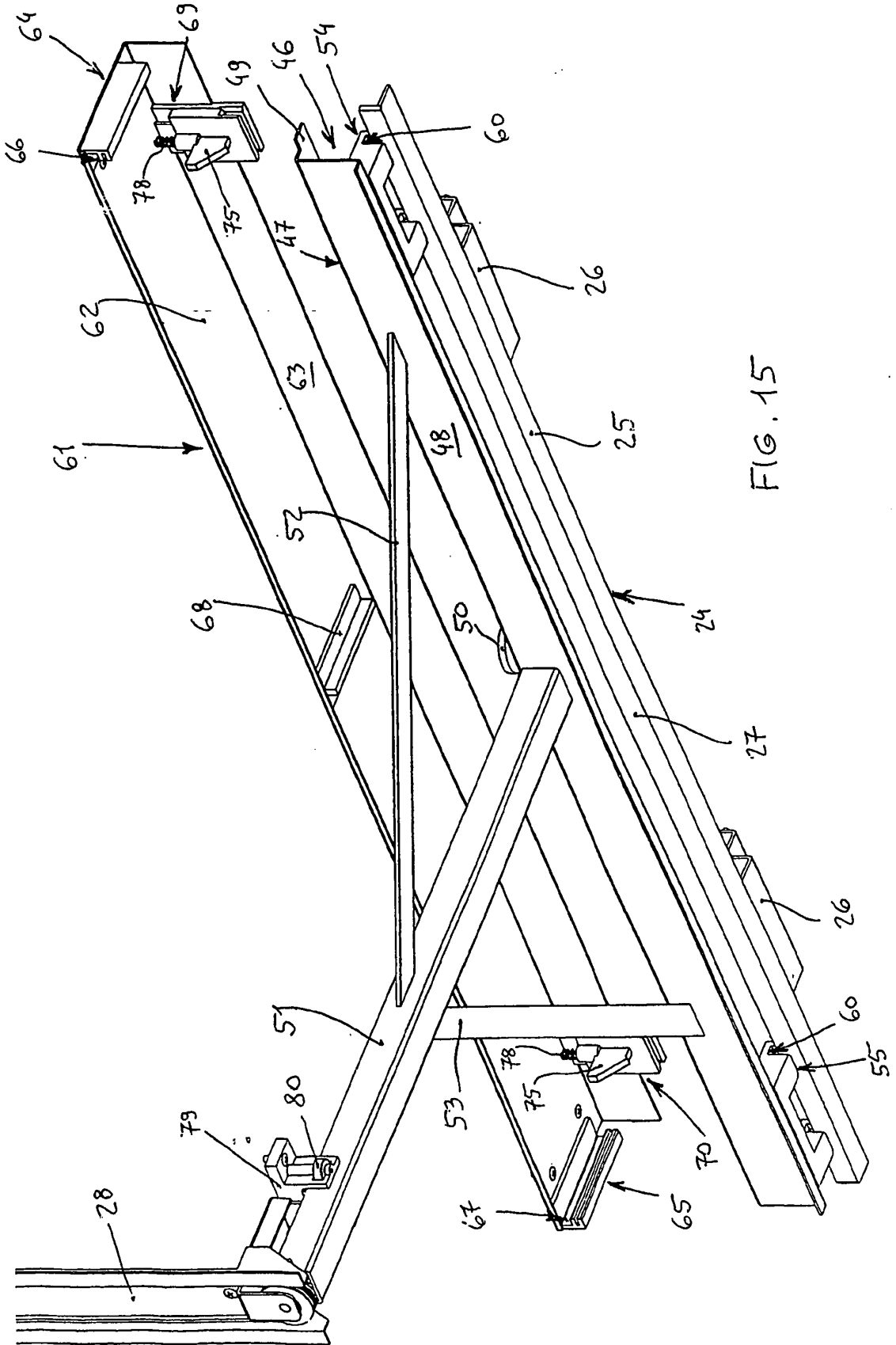

FIG. 15

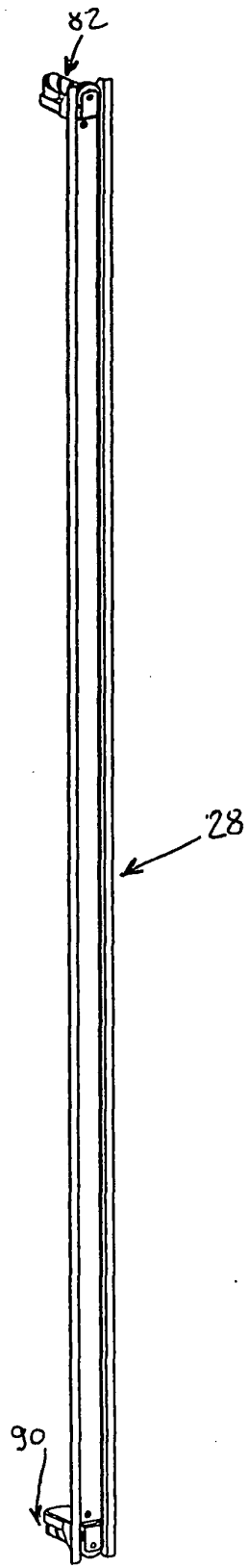

FIG. 16

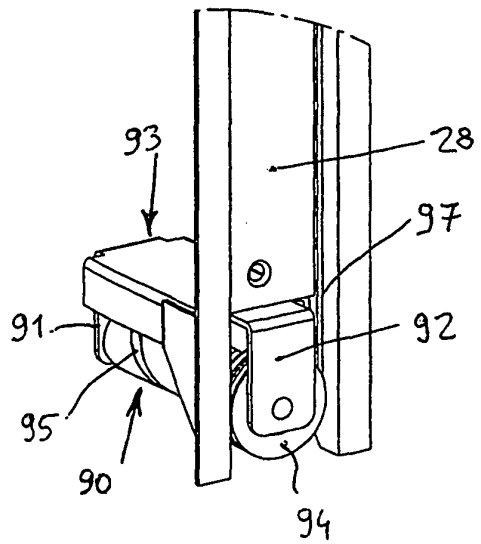
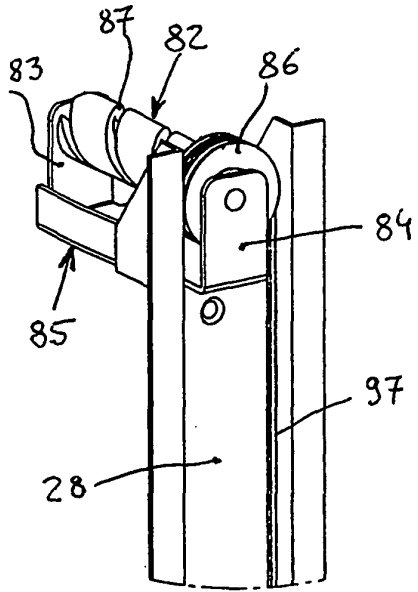

FIG. 17

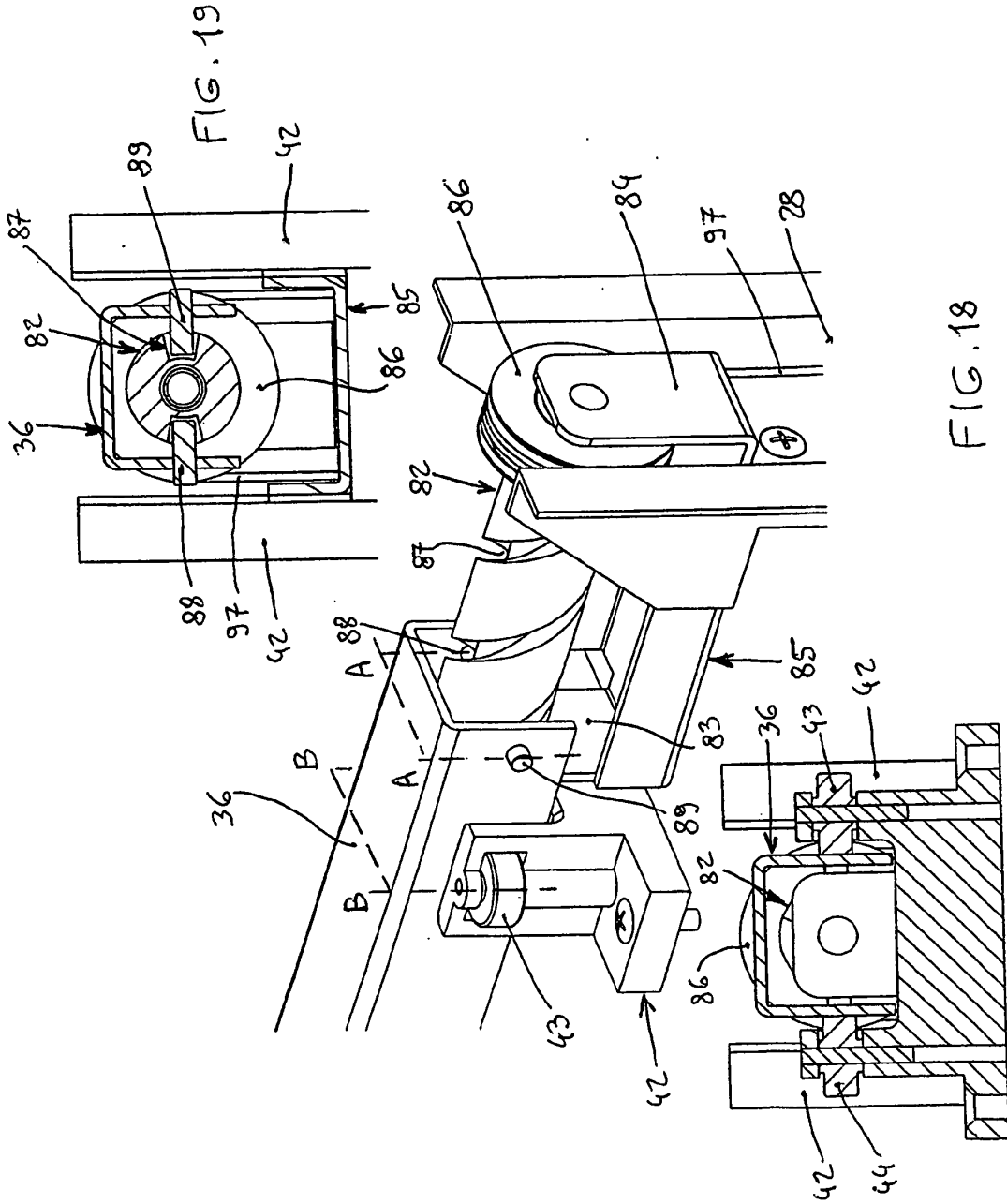
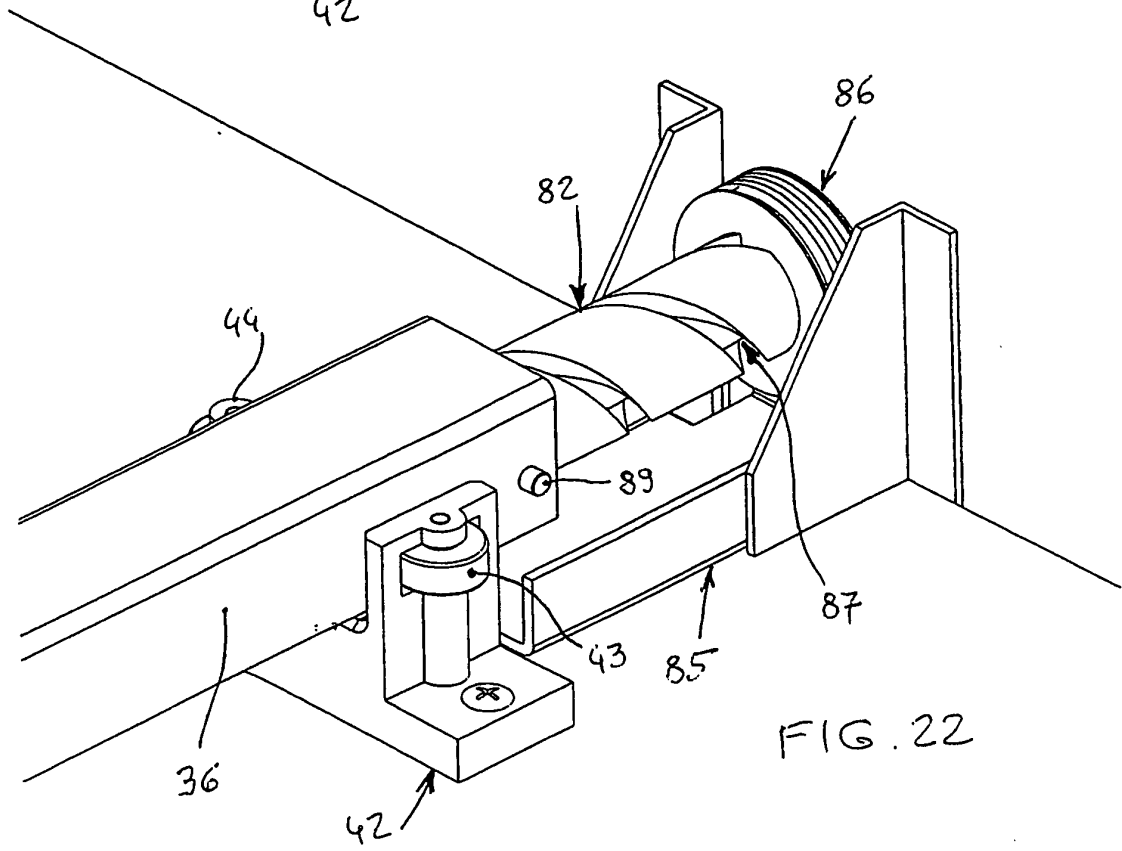
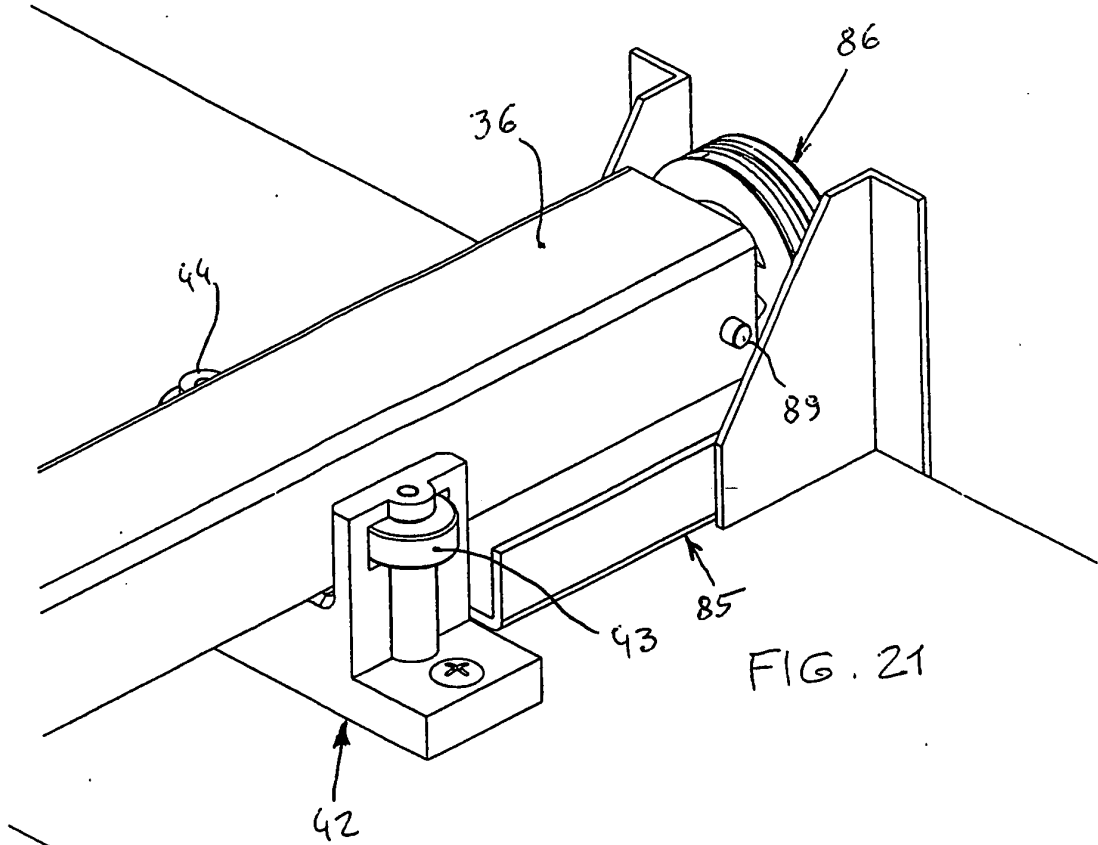

FIG. 18

FIG. 20



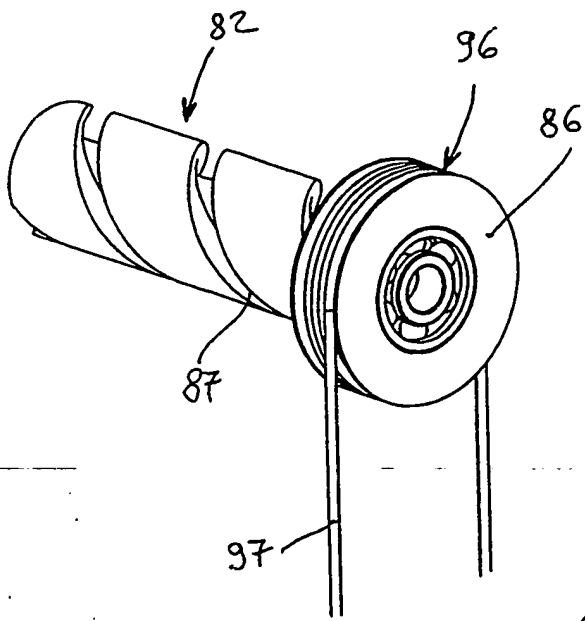

FIG. 23

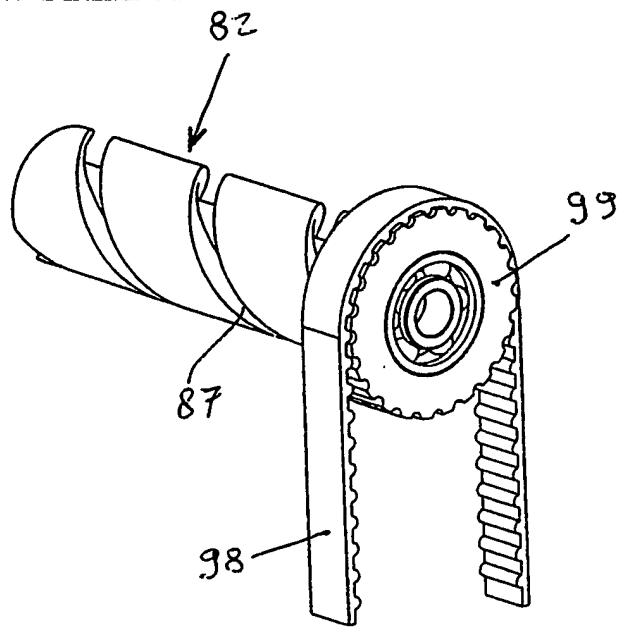

FIG. 24

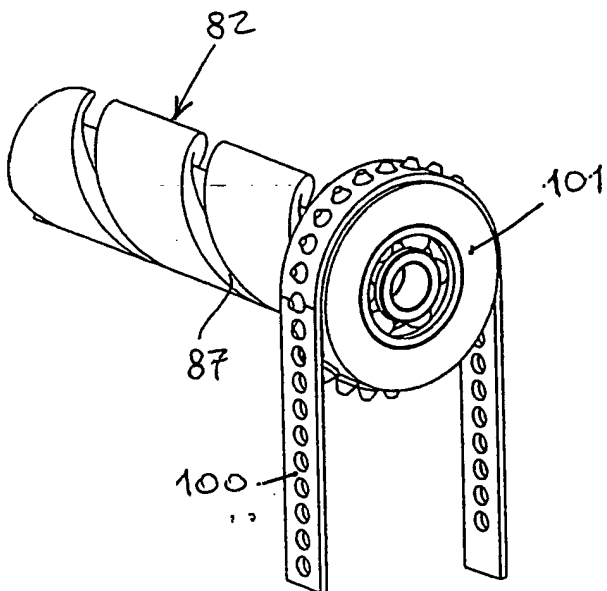

FIG. 25

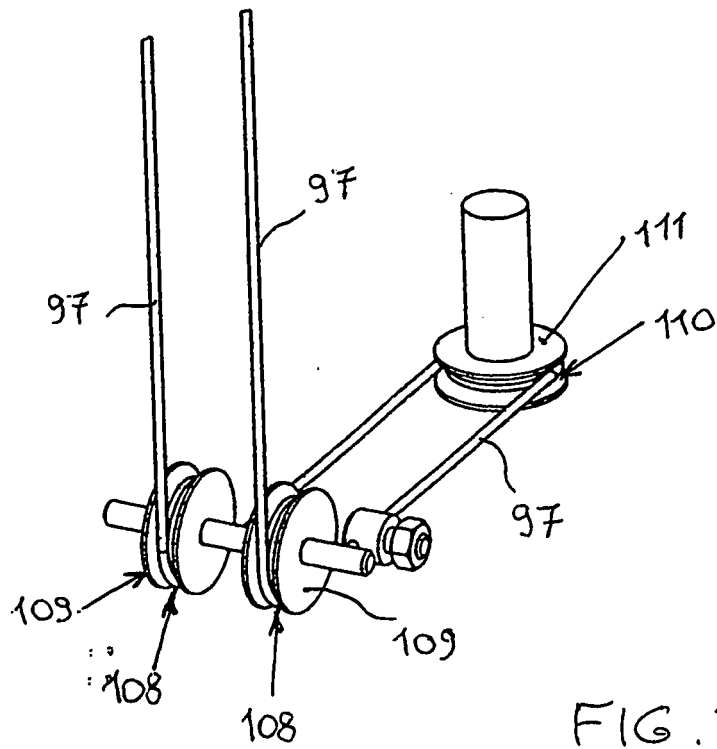
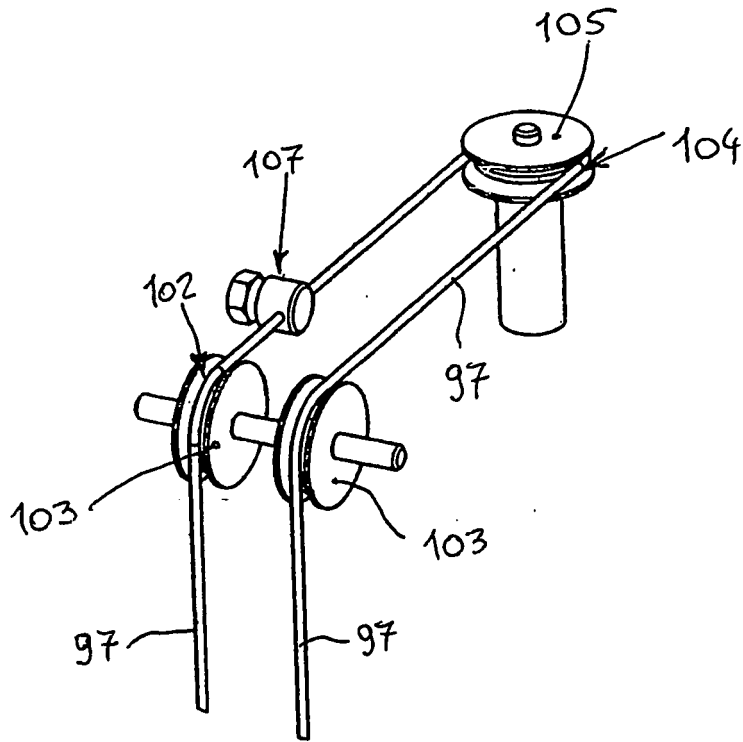
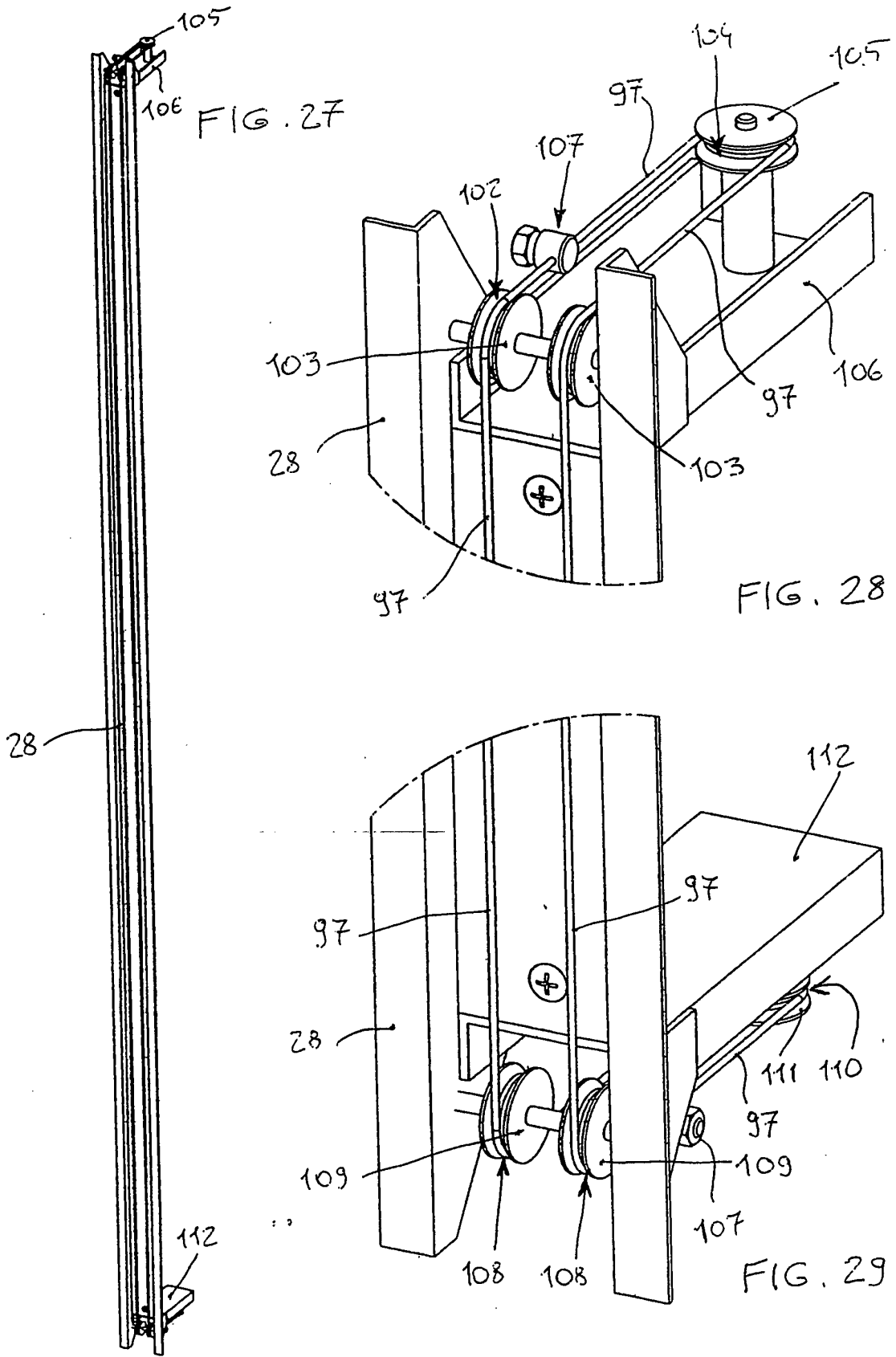
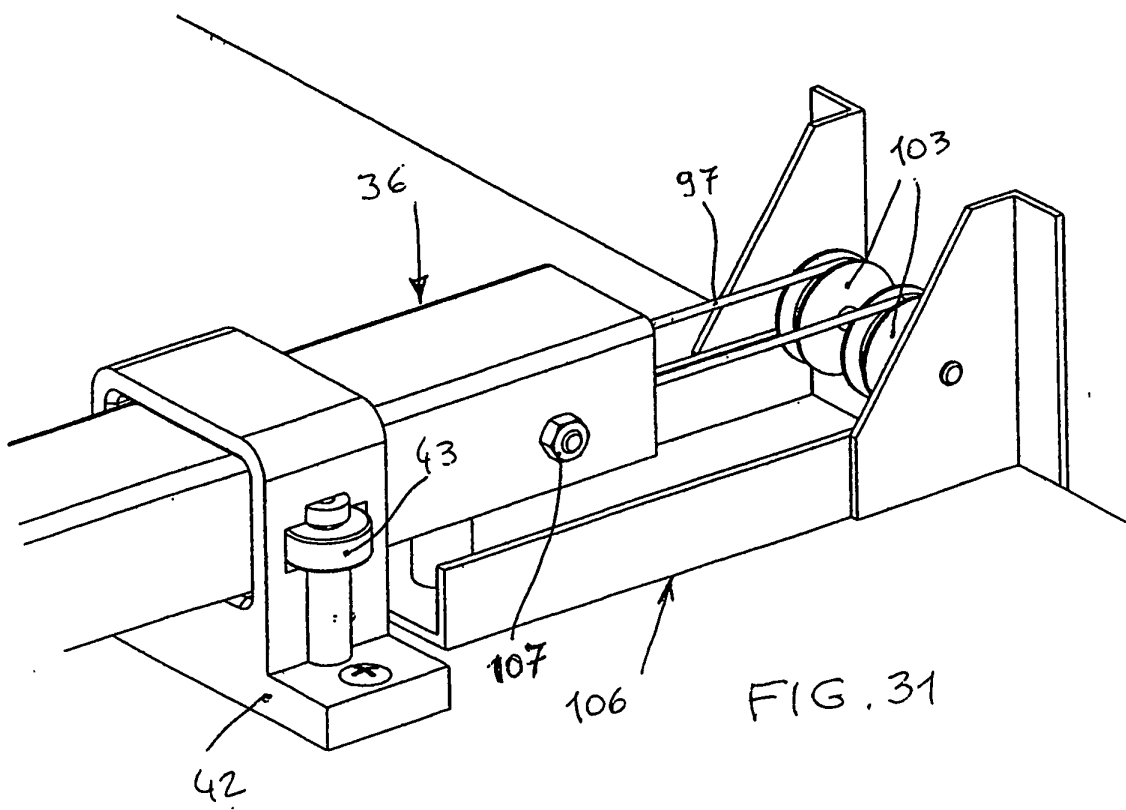
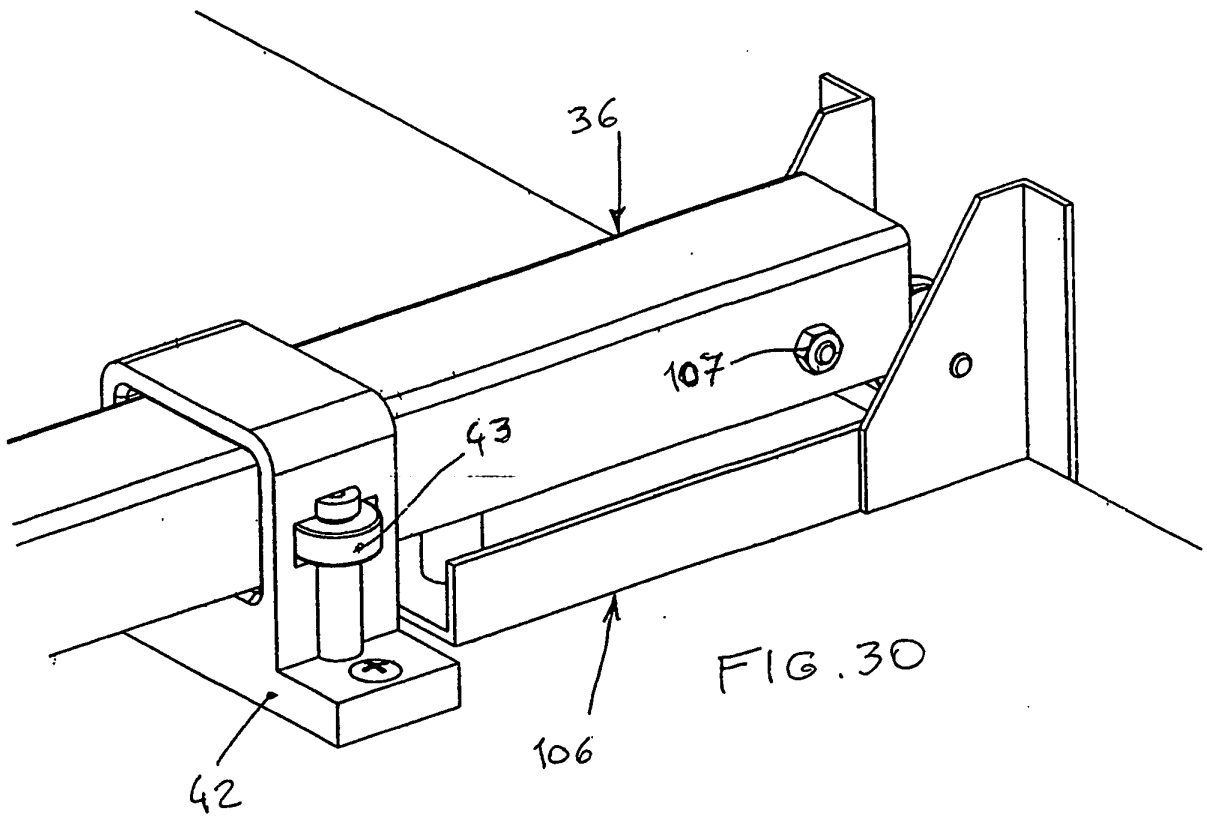
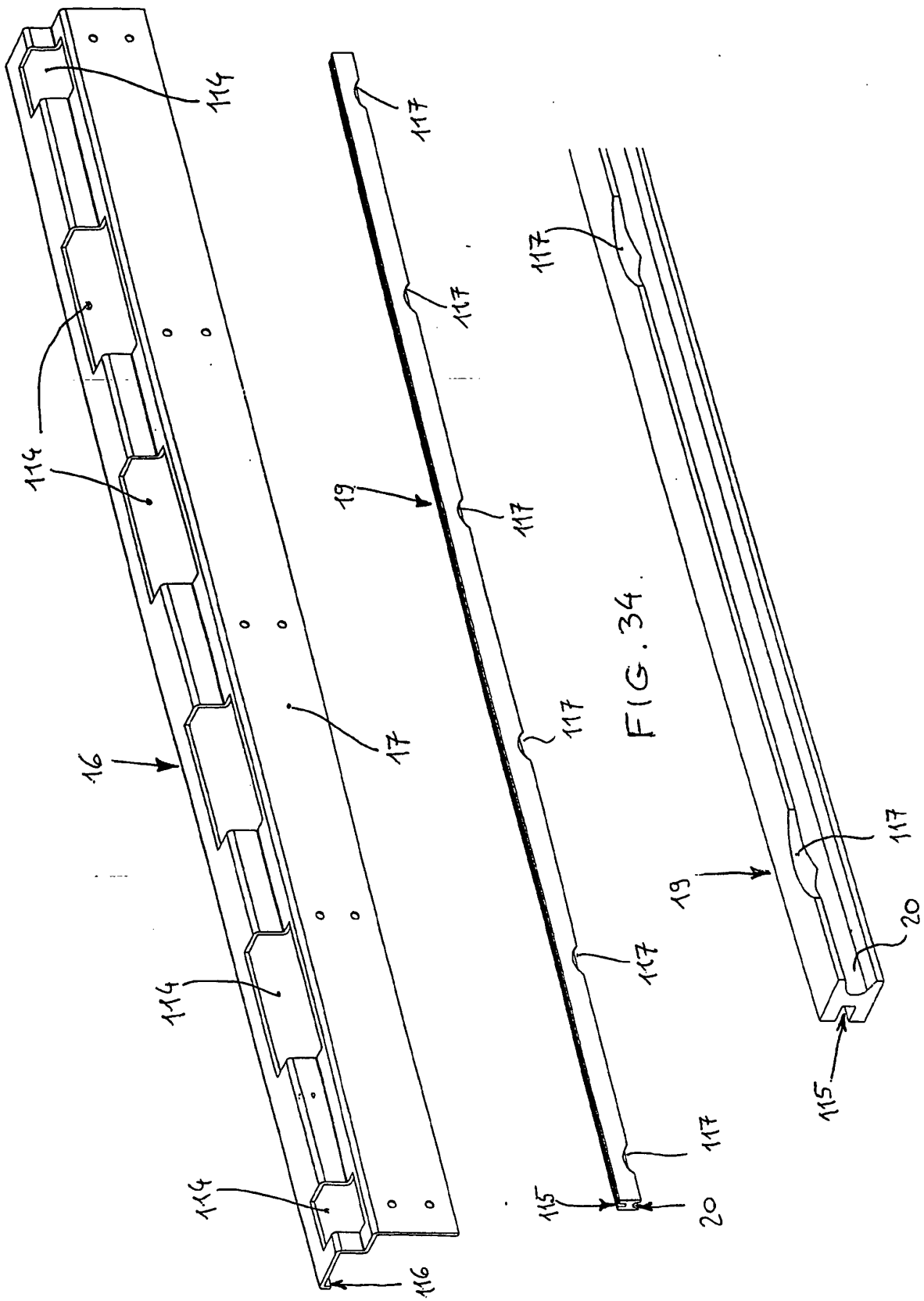

FIG. 26







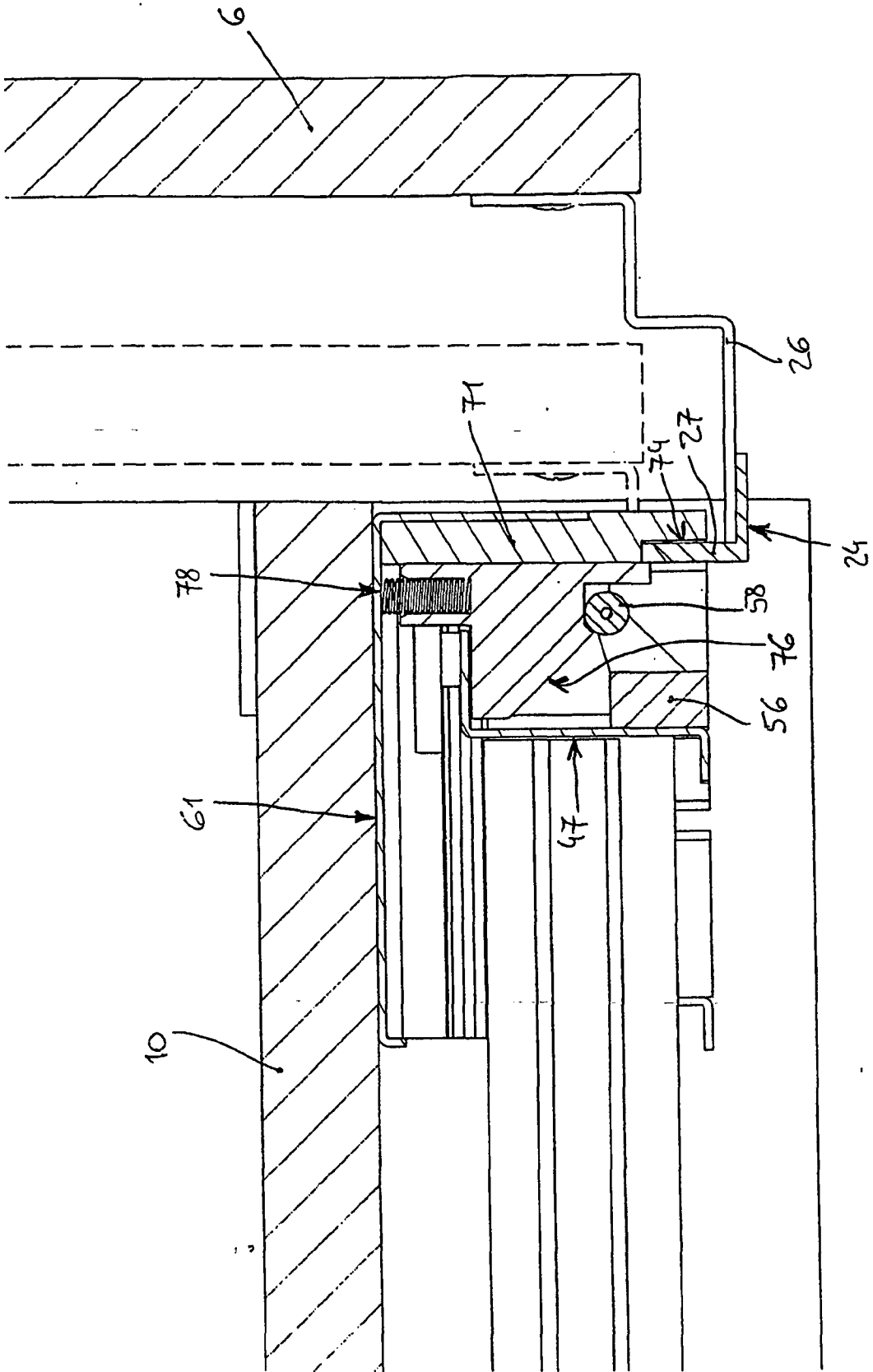
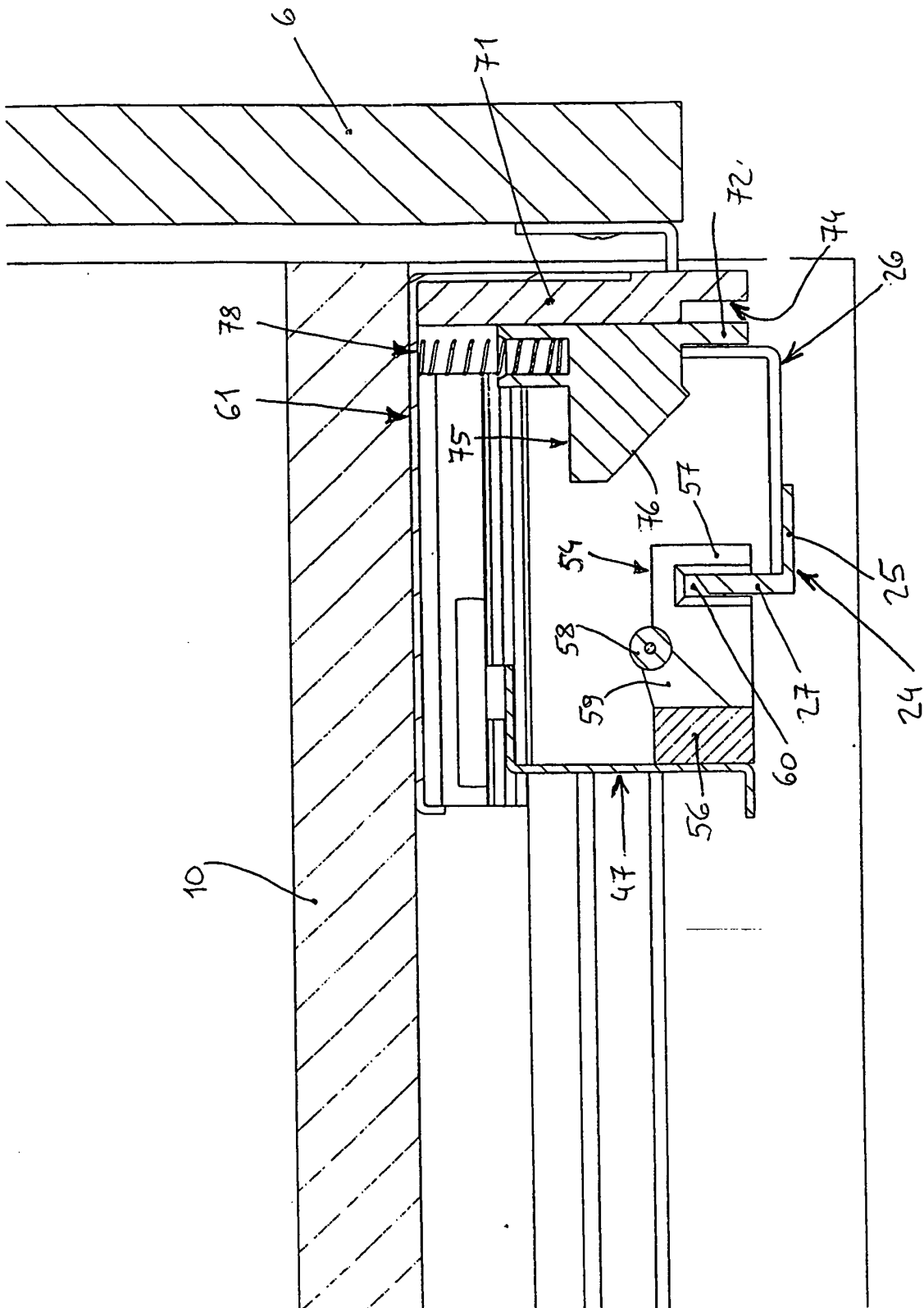
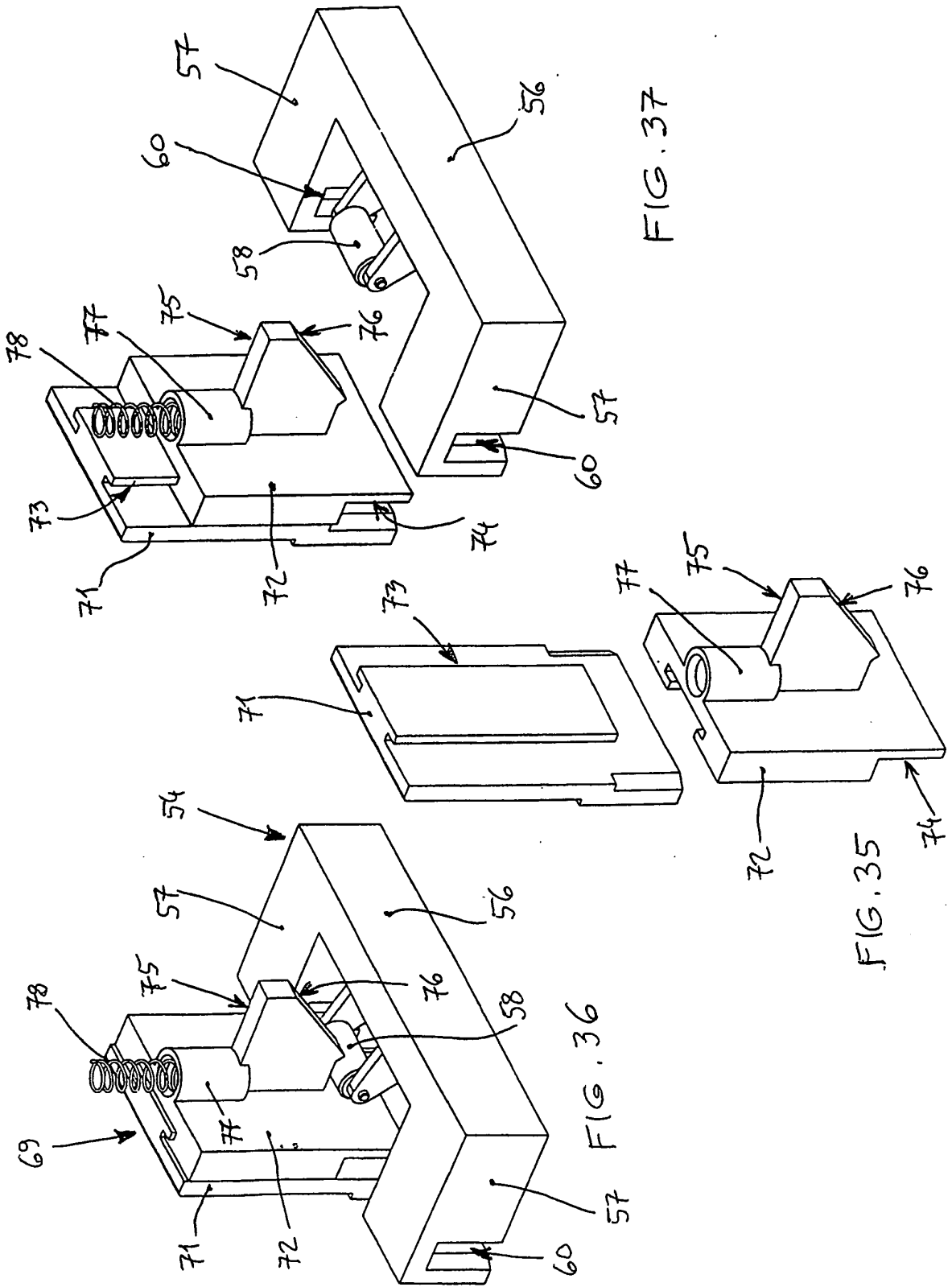

FIG. 32





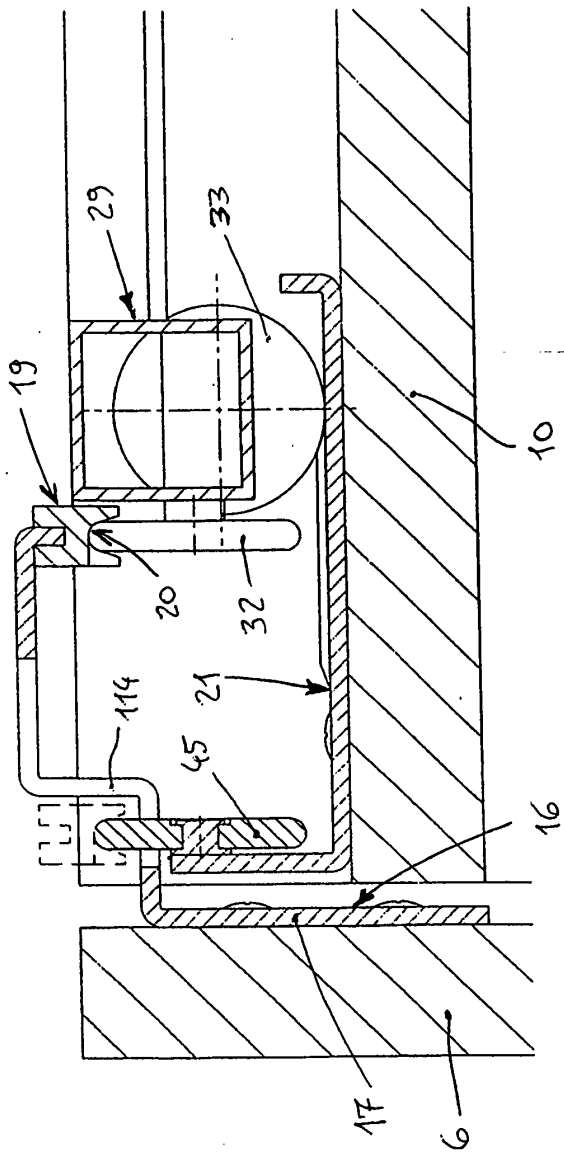

FIG. 38

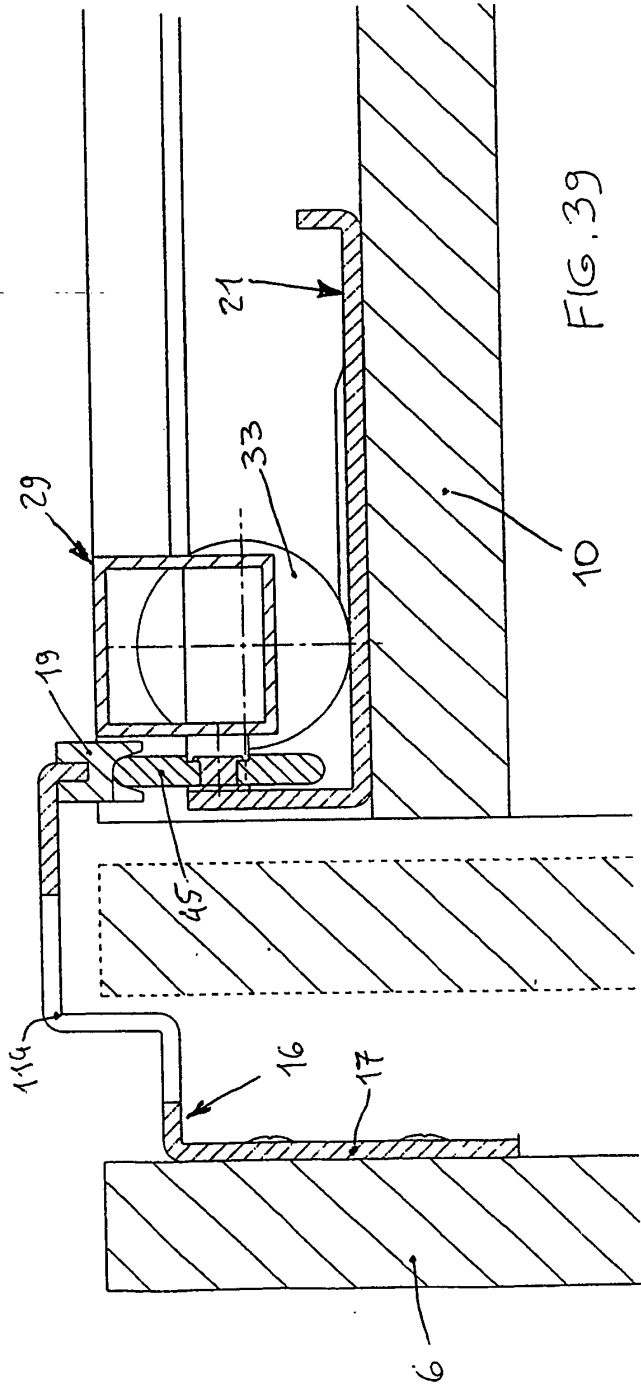
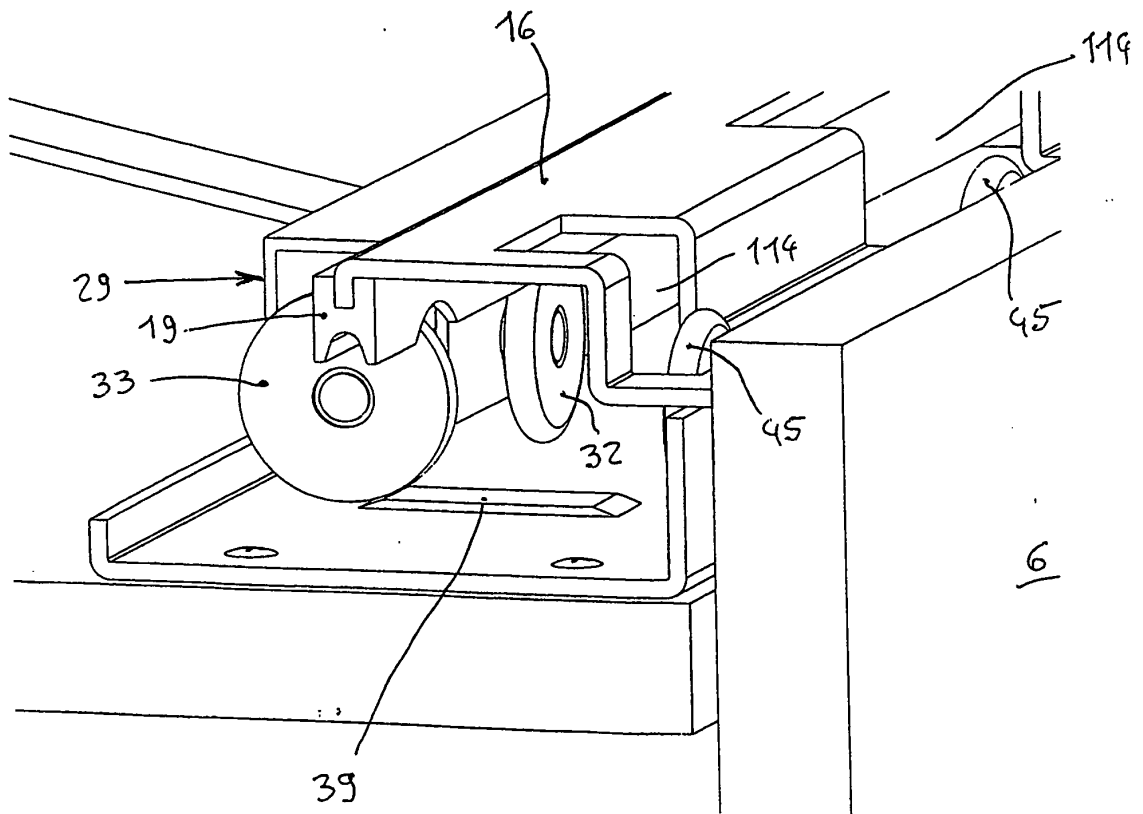
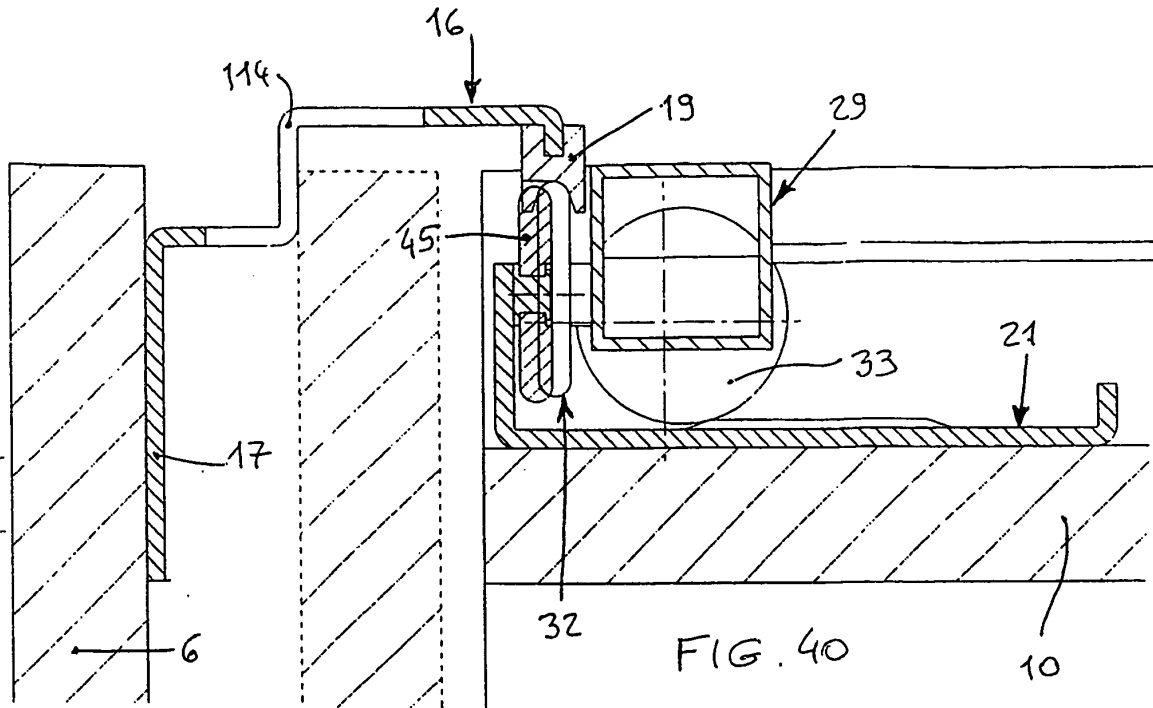

FIG. 39



REFERENCES CITED IN THE DESCRIPTION

This list of references cited by the applicant is for the reader's convenience only. It does not form part of the European patent document. Even though great care has been taken in compiling the references, errors or omissions cannot be excluded and the EPO disclaims all liability in this regard.

Patent documents cited in the description

- CH 616720 A5 [0002] [0004]