

(No Model.)

2 Sheets—Sheet 1.

A. V. CRONK.  
CAR COUPLING.

No. 417,991.

Patented Dec. 24, 1889.

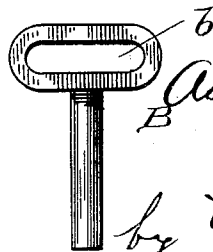
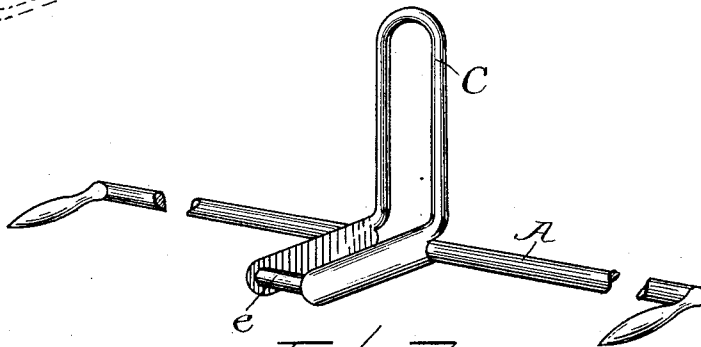
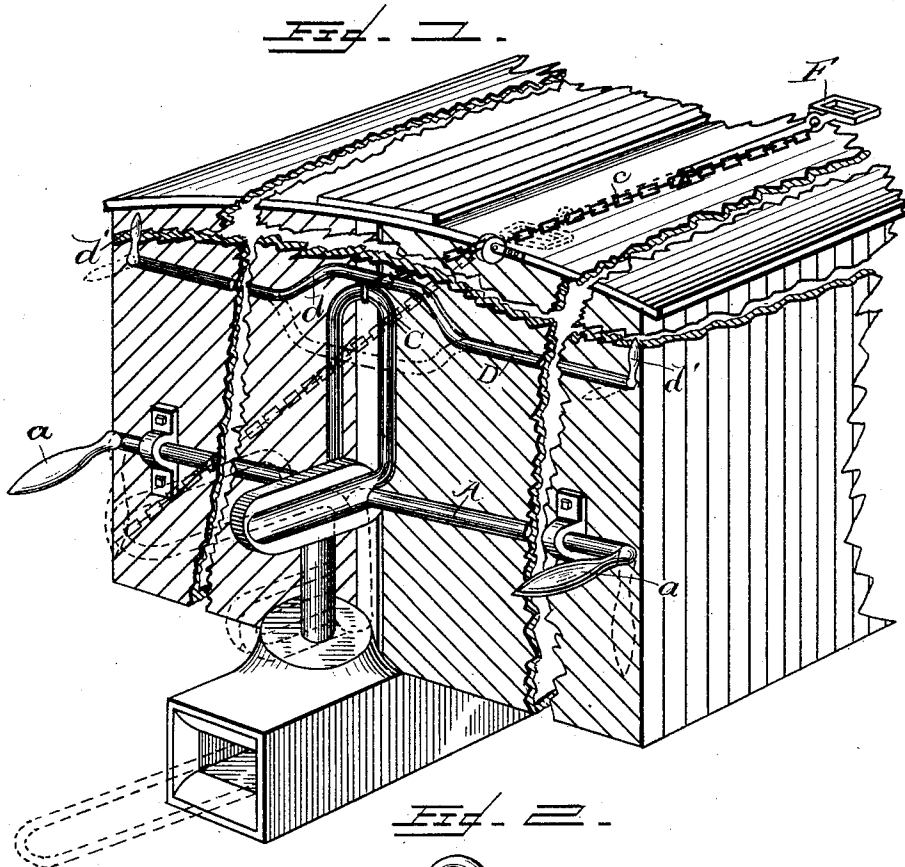

WITNESSES  
*A. J. Schwartz*  
*C. S. Fry*

*Adolphus V. Cronk*  
 INVENTOR.

by *W. Fitzgerald*  
 Attorney,

(No Model.)

2 Sheets—Sheet 2.

A. V. CRONK.  
CAR COUPLING.

No. 417,991.

Patented Dec. 24, 1889.

Fig. 4.

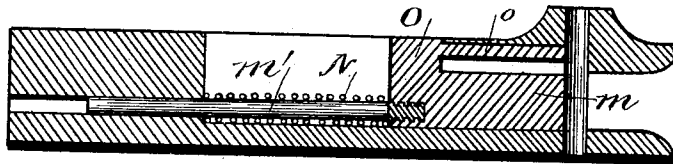
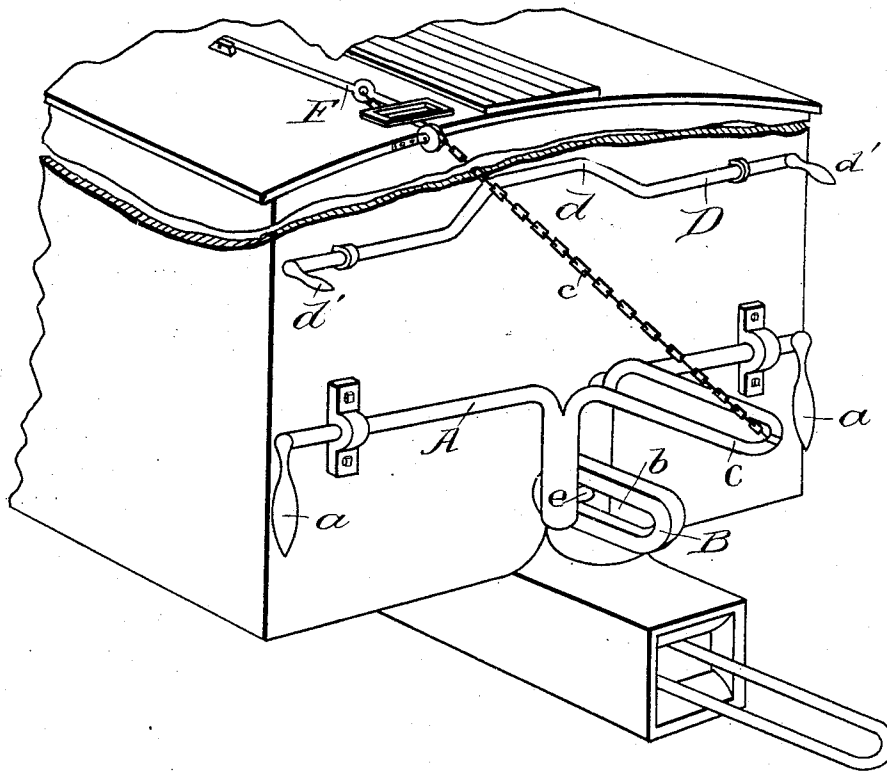

Fig. 5.



Adolphus V. Cronk

WITNESSES  
A. J. Schwartz  
C. S. Fry.

INVENTOR,  
by W. Fitzgerald  
Attorney.

# UNITED STATES PATENT OFFICE.

ADOLPHUS V. CRONK, OF ORD, NEBRASKA, ASSIGNOR OF TWO-THIRDS TO  
ARTHUR H. SCHAEFER AND JOHN W. BERAN, OF SAME PLACE.

## CAR-COUPLING.

SPECIFICATION forming part of Letters Patent No. 417,991, dated December 24, 1889.

Application filed August 13, 1889. Serial No. 320,599. (No model.)

*To all whom it may concern:*

Be it known that I, ADOLPHUS V. CRONK, a citizen of the United States, residing at Ord, in the county of Valley and State of Nebraska, have invented certain new and useful Improvements in Couplers for Railway-Cars; and I do hereby declare the following to be a full, clear, and exact description of the invention, such as will enable others skilled in the art to which it appertains to make and use the same.

My invention relates to certain novel features in constructing a simple and effective device for attaching railway-cars to each other and for readily disengaging them when it is desired that they shall be separated, the object of which is to perform this part of railway service with ready efficiency and great safety to the operator, and, while my invention is more especially applicable to the use of freight-cars, it may also prove equally efficient when applied to passenger-coaches.

I secure the above result by means of the construction shown in the following-described device, reference being had to the accompanying drawings, in which similar letters of reference designate corresponding parts in all the views.

Figure 1 is a perspective view of my invention as applied to use, showing the position occupied by my coupling device when the pin is raised, while the same view shows by means of the dotted lines the position occupied by my coupling device when the pin is lowered in position to hold the link. Fig. 2 shows the rod A, the crank formed in the middle thereof, and the upward-reaching loop, while Fig. 3 shows the locking-pin provided with a slotted head to receive the wrist in said crank. Fig. 4 is a longitudinal section of the draw-head. Fig. 5 is a perspective view of my invention, showing the pin lowered.

Referring by letter to the various parts of my invention, A is a rod, of iron or other suitable material, reaching horizontally across the end of the car and suitably journaled thereto near its outer ends, while at the middle of such rod A it is bent downward, so as to form a crank, the wrist *e* of which is to engage in the slot *b*, provided in the head of pin B, and it will be readily understood that

when such bent portion of the rod A is elevated to a horizontal position the wrist thereof, following the slot of said pin, will cause such pin to be withdrawn from the hole in the draw-head sufficiently to release the link.

To the rod A, I secure at right angles with the crank an upward-reaching bar or loop C, the object of which is to provide the means for attaching the operating-chain *c*, reaching to the top of the car, and serves the further purpose of preventing the pin from dropping back into the draw-head, as such loop may be secured snugly against the end of the car by means of the transverse bar D, properly journaled to the car and having near its middle a downward-reaching loop *d*, which may be raised to receive such loop C by means of the handles *d'*.

In order to operate the rod A, provided at its middle with the crank, as shown, I provide handles *a a*, which shall reach in a direction parallel with said crank.

The draw-head is to be provided in the usual manner with a properly-arranged spring, so that the rigidity of the blows upon the same will be mitigated.

In order to operate my coupling device from the top of the car, the chain *c* is attached to the top of the bar or loop C and secured to a properly-arranged lever F on top of the car.

I will now proceed to describe one of the essential and important features of my invention, consisting of the plunger-bolt M, having the rectangular longitudinal head *m* and cylindrical body *m'*, and further provided at the rear end and upper side of head *m* with the vertical rectangular projection O. Reaching from the front side and upper end of projection O is the longitudinal rectangular bar *o*. This plunger-bolt M, consisting of the various parts just described, is intended to fit into a correspondingly-shaped opening provided in the longitudinal draw-head, as shown in Fig. 4. A spiral spring N is to be placed around the cylindrical body *m'* before such body is entered into the longitudinal hole in the rear of the draw-head, for the obvious purpose of forcing the plunger-bolt A toward the front end of the draw-head. The rectangular bar *o* occupies a longitudinal opening immediately above that occupied by

the head *m*, thereby enabling the front end of such bar to reach forward against the coupling-pin, the obvious purpose of which is to so bear against such pin that it will be held in any position desired. It will be understood that when the link is forced inward it will strike the outer head *m*, and thereby force such head rearwardly, and as the same movement is given to the bar *o* it will also be forced backward and enable the pin to drop in place and secure the link. It will be further observed that when the pin is withdrawn the head *m*, by means of the spiral spring *N* on the cylindrical body *m'*, will force the link out of the draw-head.

Having thus described my invention, what I claim as new, and desire to secure by Letters Patent, is—

1. The combination, with a railway-car, of a coupling device consisting of the transverse rod *A*, so bent at its middle as to form the crank *E* and properly journaled to the end of the car, while the outer ends thereof are provided with handles *a a*, which reach parallel with said crank, as shown, while to the middle of such rod is attached at right angles with the crank the loop or bar *C*, to which is attached the operating-chain *c*, as shown.

2. In a coupling device for railway-cars, the lever *F*, properly secured to the top of the car and having a chain attached thereto reaching downward and secured to the top of the loop *C*, in combination with the rod *A*,

provided at its middle with the crank *E*, and further provided with loop *C*, arranged at right angles with said crank and also with handles *a a*, as shown.

3. In a coupling device for railway-cars, consisting of the draw-head provided with suitable openings for receiving the plunger-bolt *M*, consisting of the rectangular head *m* and cylindrical body *m'*, vertical projection *O*, and the forwardly-reaching bar *o*, attached to the front side and upper end of said projections, and further provided with the spiral spring *N*, as shown, the rod *A*, provided at its middle with crank *E* and loop *C*, arranged at right angles thereto, such crank being arranged to operate in the slotted head of pin *B*.

4. In a coupler for railway-cars, the combination of the rod *A*, provided near its middle with crank *E* and loop *C* and at its outer ends with handles *a a*, as shown, the pin *B*, provided with the slotted head *b*, the locking-bar *D*, provided near the middle thereof with a bend *d*, to engage with and secure the loop *C*, and handles *d' d'*, the operating-lever *F*, chain *c*, plunger-bolt *M*, and spiral spring *N*, all substantially as described, and for the purpose named.

In testimony whereof I affix my signature in presence of two witnesses.

ADOLPHUS V. CRONK.

Witnesses:

A. H. SCHAEFER,

J. W. BERAN.