



(43) International Publication Date  
26 September 2013 (26.09.2013)

(51) International Patent Classification:

*B29C 63/32* (2006.01)     *F16L 55/18* (2006.01)  
*B29C 53/78* (2006.01)     *F16L 55/162* (2006.01)

(21) International Application Number:

PCT/AU2013/000301

(22) International Filing Date:

22 March 2013 (22.03.2013)

(25) Filing Language:

English

(26) Publication Language:

English

(30) Priority Data:

2012901163     22 March 2012 (22.03.2012)     AU  
2012901162     22 March 2012 (22.03.2012)     AU

(71) Applicant: **SEKISUI RIB LOC AUSTRALIA PTY LTD** [AU/AU]; 587 Grand Junction Road, Gepps Cross, South Australia 5094 (AU).

(72) Inventors: **CENTOFANTI, Paul**; 587 Grand Junction Road, Gepps Cross, South Australia 5094 (AU). **TODD, Philip**; 587 Grand Junction Road, Gepps Cross, South Australia 5094 (AU). **WARNER, Geoff**; 587 Grand Junction Road, Gepps Cross, South Australia 5094 (AU).

(74) Agent: **MADDERNS**; GPO Box 2752, Adelaide, S. A. 5001 (AU).

(81) Designated States (unless otherwise indicated, for every kind of national protection available): AE, AG, AL, AM, AO, AT, AU, AZ, BA, BB, BG, BH, BN, BR, BW, BY, BZ, CA, CH, CL, CN, CO, CR, CU, CZ, DE, DK, DM, DO, DZ, EC, EE, EG, ES, FI, GB, GD, GE, GH, GM, GT, HN, HR, HU, ID, IL, IN, IS, JP, KE, KG, KM, KN, KP, KR, KZ, LA, LC, LK, LR, LS, LT, LU, LY, MA, MD, ME, MG, MK, MN, MW, MX, MY, MZ, NA, NG, NI, NO, NZ, OM, PA, PE, PG, PH, PL, PT, QA, RO, RS, RU, RW, SC, SD, SE, SG, SK, SL, SM, ST, SV, SY, TH, TJ, TM, TN, TR, TT, TZ, UA, UG, US, UZ, VC, VN, ZA, ZM, ZW.

(84) Designated States (unless otherwise indicated, for every kind of regional protection available): ARIPO (BW, GH, GM, KE, LR, LS, MW, MZ, NA, RW, SD, SL, SZ, TZ, UG, ZM, ZW), Eurasian (AM, AZ, BY, KG, KZ, RU, TJ, TM), European (AL, AT, BE, BG, CH, CY, CZ, DE, DK, EE, ES, FI, FR, GB, GR, HR, HU, IE, IS, IT, LT, LU, LV, MC, MK, MT, NL, NO, PL, PT, RO, RS, SE, SI, SK, SM, TR), OAPI (BF, BJ, CF, CG, CI, CM, GA, GN, GQ, GW, ML, MR, NE, SN, TD, TG).

Published:

— with international search report (Art. 21(3))

(54) Title: A WINDING MACHINE AND WINDING CAGE FOR A HELICALLY WOUND PIPE

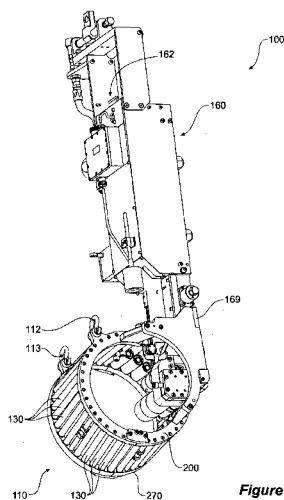

Figure 5

(57) Abstract: A winding cage, for winding a helically wound pipe from an elongate ribbed strip having at least one rib and having opposed joinable edge portions, is disclosed. The winding cage includes: a plurality of spaced apart strip guide rollers, the strip guide rollers spaced around a longitudinal winding cage axis; a proximal support frame; a distal support frame having the proximal and distal support frames spaced apart from each other and together supporting the plurality of spaced apart strip guide rollers; a proximal frame bridge, the bridge extending away from the proximal frame and bridging between spaced apart first and second ends of the proximal support frame; and a proximal mount on the bridge and a distal mount on the distal support frame, the proximal and distal mounts for receiving a strip driver assembly, the strip driver assembly for driving the strip into the winding cage. The bridge forms part of a mouth opening into the winding cage. The mouth is for accommodating the strip driver assembly.



**A WINDING MACHINE AND WINDING CAGE FOR A HELICALLY WOUND PIPE****PRIORITY DOCUMENTS**

**[0001]** The present application claims priority from:

Australian Provisional Patent Application No. 2012901162 titled "A WINDING MACHINE AND WINDING CAGE FOR A HELICALLY WOUND PIPE" and filed on 22 March 2012; and

Australian Provisional Patent Application No. 2012901163 titled "A WINDING MACHINE AND WINDING CAGE FOR A HELICALLY WOUND PIPE" and filed on 22 March 2012.

The content of each of these applications is hereby incorporated by reference in their entirety.

**TECHNICAL FIELD**

**[0002]** The invention relates to an apparatus for lining pipes or conduits with a helically wound pipe. The invention relates in particular to a winding machine for relining a conduit where the pipe is wound within the conduit.

**BACKGROUND**

**[0003]** The applicant has developed various technologies to allow trenchless pipe rehabilitation. The applicant's International Patent Application No. PCT/AU87/00069 titled "Method and Means for Lining and Overwrapping Conduits" described a method and means of lining conduits, pipes or tunnels. The method described in that patent included helically winding a strip into a pipe and holding the pipe at a selected diameter during placement within the pipe to be rehabilitated. The method described further included the step of applying pulling force to the newly helically wound pipe to cause the inter engaged edges of the strips forming the pipe to slip with respect with each other so as to increase the diameter of the pipe progressively until it engages the walls of the conduit to be relined.

**[0004]** A further patent application by the applicant, PCT/AU88/00311 titled "Slip Control for Helically Wound Pipes" deals with the problem of positively unlocking the pipe to allow for a controlled diameter change.

**[0005]** The technology described above can be described as an expanding helically wound pipe technology. The expanding helically wound pipe technology involves positioning a winding cage underground within a host conduit or pipe, or adjacent to a host conduit or pipe, as is described in the above mentioned International Patent Application No. PCT/AU87/00069. This often requires enlargement of the access area adjacent the pipe to be relined to accommodate the winding cage. Enlargement, or "chop-out", typically involves jack hammering concrete which takes considerable effort and time.

[0006] Even where pipes are wound at a final diameter using a winding cage underground within a host pipe (without subsequently expanding the wound pipe), enlargement of the access area adjacent the pipe to be relined to accommodate the winding cage is often required.

[0007] It is an object of the present invention to overcome at least some of the problems outlined above or to at least offer the public a useful choice.

## SUMMARY

[0008] According to a first aspect, there is provided a winding cage for winding a helically wound pipe from an elongate ribbed strip having at least one rib and having opposed joinable edge portions, the winding cage forming a guide for the helically wound pipe, the winding cage including:

- a plurality of spaced apart strip guide rollers, each strip guide roller having a proximal end and a distal end, the strip guide rollers spaced around a longitudinal winding cage axis;

- a proximal support frame having a plurality of guide roller proximal end supports for supporting the proximal ends of the strip guide rollers;

- a distal support frame having a plurality of guide roller distal end supports for supporting the distal ends of the strip guide rollers, the proximal and distal support frames spaced apart from each other and together supporting the plurality of spaced apart strip guide rollers;

- a proximal frame bridge, the bridge extending away from the proximal frame and bridging between spaced apart first and second ends of the proximal support frame; and

- a proximal mount on the bridge and a distal mount on the distal support frame, the proximal and distal mounts for receiving a strip driver assembly, the strip driver assembly for driving the strip into the winding cage,

- whereby the bridge forms part of a mouth opening into the winding cage, the mouth for accommodating the strip driver assembly.

[0009] In one embodiment, the mouth has a width greater than a length of a longest of the plurality of spaced apart strip guide rollers.

[0010] In one embodiment, a winding cage includes at least one rib support roller, the at least one rib support roller extending radially inwards from a shaft extending between the proximal and distal support frames, whereby, in use, the rib support roller engages at least one rib of the strip, thereby laterally guiding the strip.

[0011] In one embodiment the at least one rib support roller includes at least one flange, in use the flange engaging the at least one rib of the strip, thereby laterally guiding the strip.

**[0012]** In one embodiment, each strip guide roller is rotatable about a strip guide roller axis, the strip guide roller axes at a first radius spaced around the longitudinal winding cage axis and

wherein the at least one rib support roller is rotatable around a rib support roller axis, the rib support roller axis spaced from the longitudinal winding cage axis at a second radius, the second radius smaller than the first radius.

**[0013]** In one embodiment the winding cage includes a rib support roller, the rib support roller mounted to rotate about an axis that extends radially inwards from a shaft extending between the proximal and distal support frames,

whereby, in use, the rib support roller engages at least one rib of the strip, thereby laterally guiding the strip.

**[0014]** According to a second aspect, there is provided winding cage for winding a helically wound pipe from an elongate ribbed strip having at least one rib and having opposed joinable edge portions, the winding cage forming a guide for the helically wound pipe, the winding cage including:

a plurality of spaced apart strip guide rollers, each strip guide roller having a proximal end, a distal end and a strip guide roller axis, the strip guide rollers axes spaced around a longitudinal winding cage axis at a first radius, the strip guide rollers having a strip roller maximum radius;

a proximal support frame having a plurality of proximal guide roller supports for supporting the proximal ends of the strip guide rollers;

a distal support frame having a plurality of distal guide roller supports for supporting the distal ends of the strip guide rollers, the proximal and distal support frames spaced apart from each other and together supporting the plurality of spaced apart strip guide rollers; and

a plurality of rib support rollers, each rib support roller having a rib support roller axis, the rib support axes spaced around the longitudinal winding cage axis at a second radius, the second radius smaller than the first radius.

**[0015]** In one embodiment, the at least one rib support roller includes at least one flange, in use the flange engaging the at least one rib of the strip, thereby laterally guiding the strip.

**[0016]** In one embodiment, the rib support roller is mounted to rotate about an axis that extends radially inwards from a shaft extending between the proximal and distal support frames.

**[0017]** According to a third aspect, there is provided a winding machine for winding a helically wound pipe from an elongate ribbed strip having at least one rib and having opposed joinable edge portions, the winding machine including a winding cage and a powered strip driver assembly for driving the strip into the winding cage, the winding cage forming a guide for the helically wound pipe, the winding cage

including:

a plurality of spaced apart strip guide rollers, each strip guide roller having a proximal end and a distal end, the strip guide rollers spaced around a longitudinal winding cage axis;

a proximal support frame having a plurality of guide roller proximal end supports for supporting the proximal ends of the strip guide rollers; and

a distal support frame having a plurality of guide roller distal end supports for supporting the distal ends of the strip guide rollers, the proximal and distal support frames spaced apart from each other and together supporting the plurality of spaced apart strip guide rollers,

wherein the proximal support frame includes a first end and a second end, the first and second ends spaced apart so as to provide an opening for accommodating the strip driver assembly.

[0018] In one embodiment, the proximal support frame is shaped to describe part of an annulus between the spaced apart ends.

[0019] In one embodiment, the spaced apart ends of the proximal support frame form part of a mouth, the mouth having a width greater than a length of a longest of the plurality of spaced apart strip guide rollers.

[0020] In one embodiment, the bridge bridging between the spaced apart first and second ends of the proximal support frame,

whereby the bridge forms part of the mouth, the mouth for accommodating the strip driver assembly.

[0021] In one embodiment, wherein the bridge includes a mount, the mount connecting the strip driver assembly to the bridge and thereby to the proximal support frame.

[0022] In one embodiment, the strip driver assembly includes a strip entrance and a strip exit and a pair of pinch rollers for driving the strip, the pinch rollers located adjacent to the strip exit, wherein the pinch rollers include a driver mounted around a pinch roller drive shaft,

whereby the spaced apart ends of the annulus accommodate a portion of the strip driver assembly adjacent the driver.

[0023] In one embodiment, the driver includes a sprocket, the sprocket driven by a looped transmission member.

[0024] In one embodiment, the looped transmission member includes a chain.

[0025] In one embodiment, the looped transmission member includes a belt.

**[0026]** In one embodiment, the winding machine includes at least one rib support roller, the at least one rib support roller extending radially inwards from a shaft extending between the proximal and distal support frames, whereby, in use, the rib support roller engages at least one rib of the strip, thereby laterally guiding the strip.

**[0027]** In one embodiment, the at least one rib support roller includes at least one flange, in use the flange engaging the at least one rib of the strip, thereby laterally guiding the strip.

**[0028]** In one embodiment, each strip guide roller is rotatable about a strip guide roller axis, the strip guide roller axes at a first radius spaced around the longitudinal winding cage axis; and

the at least one rib support roller is rotatable around a rib support roller axis, the rib support roller axis spaced from the longitudinal winding cage axis at a second radius, the second radius smaller than the first radius.

**[0029]** In one embodiment, the winding machine includes a rib support roller, the rib support roller mounted to rotate about an axis that extends radially inwards from a shaft extending between the proximal and distal support frames,

whereby, in use, the rib support roller engages at least one rib of the strip, thereby laterally guiding the strip.

**[0030]** According to a fourth aspect, there is provided a winding machine for winding a helically wound pipe from an elongate ribbed strip having at least one rib and having opposed joinable edge portions, the winding machine including a winding cage and a powered strip driver assembly for driving the strip into the winding cage, the winding cage forming a guide for the helically wound pipe, the winding cage including:

a plurality of spaced apart strip guide rollers, each strip guide roller having a proximal end, a distal end and a strip guide roller axis, the strip guide rollers axes spaced around a longitudinal winding cage axis at a first radius, the strip guide rollers having a strip roller maximum radius;

a proximal support frame having a plurality of proximal guide roller supports for supporting the proximal ends of the strip guide rollers;

a distal support frame having a plurality of distal guide roller supports for supporting the distal ends of the strip guide rollers, the proximal and distal support frames spaced apart from each other and together supporting the plurality of spaced apart strip guide rollers; and

a plurality of rib support rollers, each rib support roller having a rib support roller axis, the rib support axes spaced around the longitudinal winding cage axis at a second radius, the second radius smaller than the first radius.

[0031] In one embodiment the at least one rib support roller includes at least one flange, in use the flange engaging the at least one rib of the strip, thereby laterally guiding the strip.

[0032] In one embodiment the rib support roller is mounted to rotate about an axis that extends radially inwards from a shaft extending between the proximal and distal support frames.

[0033] A detailed description of one or more embodiments of the invention is provided below along with accompanying figures that illustrate by way of example the principles of the invention. While the invention is described in connection with such embodiments, it should be understood that the invention is not limited to any embodiment. On the contrary, the scope of the invention is limited only by the appended claims and the invention encompasses numerous alternatives, modifications and equivalents. For the purpose of example, numerous specific details are set forth in the following description in order to provide a thorough understanding of the present invention.

[0034] The present invention may be practiced according to the claims without some or all of these specific details. For the purpose of clarity, technical material that is known in the technical fields related to the invention has not been described in detail so that the present invention is not unnecessarily obscured.

#### **BRIEF DESCRIPTION OF DRAWINGS**

[0035] Embodiments of the present invention will be discussed with reference to the accompanying drawings wherein:

[0036] Figure 1 shows a schematic cross-sectional view of an underground conduit being relined using a prior art winding machine.

[0037] Figure 2a is an isometric view of a winding machine that can be used in a conduit such as that shown in Figure 1.

[0038] Figure 2b shows a schematic cross-sectional view of the winding machine of Figure 2a within an invert of an underground conduit.

[0039] Figure 3a is a cross-sectional view of a strip (or "profile") used to helically wind pipe as shown in Figure 1.

[0040] Figure 3b is a cross-sectional view of an alternative strip used to helically wind pipe as shown in Figure 1.

[0041] Figure 3c is a cross-sectional view showing two convolutions of the strip of Figure 3a joined together.

[0042] Figure 4 is a similar view to Figure 1 but illustrates use of a winding machine according to the present invention.

[0043] Figure 5 is an isometric view of a winding machine according to the invention.

[0044] Figure 6 shows a schematic cross-sectional view of the winding machine of Figure 5 within an invert of an underground conduit.

[0045] Figure 7a is a front view of the winding machine shown in Figure 5.

[0046] Figure 7b is a magnified view of a portion of the winding machine shown in Figure 7a with portions of the machine removed to show internal detail.

[0047] Figure 7c is a cross sectional view taken through section line 7c-7c on Figure 7b.

[0048] Figures 8, 9 and 10 are an isometric view of the winding cage that forms part of the winding machine of Figure 5.

[0049] Figure 11 shows rib support rollers of the winding cage of Figures 8, 9 and 10.

[0050] Figure 12 is an isometric view of an alternative winding cage to that shown in Figure 8.

[0051] Figure 13 is an isometric view of a further alternative winding cage to that shown in Figure 8, the machine having different rib support rollers to the rib support rollers of Figure 12.

[0052] Figure 14 shows rib support rollers of the winding cage of Figure 13.

[0053] Figure 15 is a diagrammatic end view of view of the winding cage of Figure 13.

## **DESCRIPTION OF EMBODIMENTS**

[0054] Referring to Figures 1, 2a and 2b, it is known to reline conduits such as sewer or storm water conduits with helically wound pipe 9 using a pipe winding machine 50. The conduit or host pipe being relined may be of circular, oval, square or rectangular cross-section for instance. Irrespective of the shape of the host pipe, it is generally desirable to wind a new pipe with a cross-sectional area as close as possible to a cross-sectional area of the host pipe. Where winding a new pipe into a host pipe having a

circular cross-section, it is generally desirable to minimise the distance between the outside diameter of the newly wound pipe and the inside diameter of the host pipe. This is the case irrespective of whether, subsequent to winding, the new pipe is expanded out to a larger diameter or not.

[0055] Some clearance is required between the wound pipe 9 and the host pipe 5 in order to allow the newly wound pipe 9 to move longitudinally with respect to the host pipe 5 before the wound pipe 9 is expanded.

[0056] It is often necessary to enlarge the access area adjacent the pipe to be realigned to accommodate the winding cage 60 of the winding machine 50. The enlarged or "chop-out" area 6 is illustrated in Figure 1. The enlargement or chop-out typically involves jack-hammering concrete which takes considerable effort and time.

[0057] The extent of the chop-out required can be more clearly appreciated with reference to Figure 2b. In Figure 2b the inside wall of the host pipe 5 is illustrated and the winding cage 60 is shown protruding through into the concrete into the region 6. In practice, the arrangement shown in Figure 2b does not occur. Instead, the region of the conduit or host pipe 5 where the winding cage is to be positioned is enlarged in the region 6 as shown in Figure 1.

[0058] Turning now to Figures 3a and 3c, a composite strip useable with the winding machine illustrated in figure 2 or the winding machine according to the invention of Figure 5 are shown. These strips of profiles include a base 12, a male edge 14, a female edge 18 and a plurality (in this case 3) of upstanding ribs 20. Each rib 20 has a crown portion 25. The base 12 of the strip forms the inner surface of the wound pipe.

[0059] An alternative strip 10 that can also be wound into a helical pipe is shown in Figure 3b.

[0060] Figures 3a and 3c show the mechanical join between female edges 18 and male edges 14'. The strip 10 has a primary male locking portion 15 and a secondary, or sacrificial, male locking portion 16 on its male edge 14. On its female edge 18, the strip 10 has a female primary locking portion 35 and a female secondary locking portion 36.

[0061] The function of the primary and secondary locking portions are as described in the applicants earlier Patent Applications Nos PCT/AU87/00069 and PCT/AU88/00311 (referred to above) that are hereby incorporated by reference.

[0062] Various alternative joining methods may be used. For instance, welding or gluing may be used with different male and female edge portions (not shown).

[0063] A winding machine 100 according to the invention is shown in Figures 4, 5 and 6. The winding machine 100 is used for helically winding a helically wound pipe from an elongate rib strip such as the strip shown in Figure 3a. The winding machine 100 includes a winding cage 110 and a powered strip driver assembly in the form of a drive tray 160 for driving the strip into the winding cage 110. The winding cage 110 forms a guide for the helically wound pipe. The winding cage 110 includes a proximal and a distal support frame 200 and 270 respectively. The proximal frame 200 and the distal frame 270 are spaced apart from each other and support a plurality of circumferentially spaced apart strip guides in the form of rollers 130 that extend there-between. The proximal support frame 200 is shaped to form part of an annulus.

[0064] The drive tray 160 has a mounting plate 169 that attaches to the winding cage 110 as can be seen in figures 5 and 6. Drive tray mounting plate receiving mounts are most clearly shown in Figures 8, 9 and 10.

[0065] Lifting hooks 112 and 113 are provided at the top of the winding cage 110 for lifting and manoeuvring the winding cage 110 and winding machine 100.

[0066] Turning to Figure 8, the winding cage 110 is more clearly shown with the drive tray removed. The proximal support frame 200 has spaced apart ends 202 and 204 to accommodate the drive tray 160. This figure also shows how the proximal support frame 200 includes roller proximal end supports 134 and the distal support frame 270 includes roller distal end supports 136 to support rollers 130 that span between frame 200 and 270.

[0067] The winding cage 110 includes a proximal frame bridge 300, the bridge 300 bridging between the spaced apart first and second ends 202 and 204 of the proximal support frame 200. The bridge extends away from the proximal frame 200 and bridges between spaced apart first and second ends 202, 204 of the proximal support frame 200.

[0068] Again referring to Figure 8, a proximal mount 390 on an offset plate 315, which forms part of the bridge 300, and a distal mount 290 on the distal support frame 270 are shown. The proximal and distal mounts 390, 290 are for receiving the strip driver assembly.

[0069] The bridge 300 is shaped to form part of a mouth 320, the mouth 320 accommodating the strip driver assembly in the form of a drive tray 160.

[0070] Figure 8 shows that the bridge includes an offset plate 315 and a pair of linking plates 316 and 317. A slightly different linking plate 316' is shown for the winding cage of Figures 12 and 13.

[0071] Referring to Figures 7a and 7b, the axes 131 of two of the spaced apart strip guide rollers 130 are shown. These strip guide rollers axes 131 are spaced around a longitudinal winding cage axis 111 at a first radius  $R_1$ .

[0072] Again referring to Figure 7a, it can be seen that the drive tray 160 has a drive tray entrance 162 that, in use, receives a strip 10 having a male edge 14 and a female edge 18 (the strip shown in Figure 3a for instance). The drive tray also has a pair of pinch rollers that can be seen in the enlarged view of Figure 7b and the cross-sectional view taken through section line 7c-7c of Figure 7c. The pinch rollers drive the strip 10 into the cage 110. The pinch rollers 175 and 170, most clearly seen in Figure 7c, are located adjacent the drive tray strip exit 168 as indicated in Figure 7b.

[0073] Referring again to Figure 7b, this view has a number of the rollers 130 removed and has a portion of the proximal frame removed so as to better illustrate the pinch roller 175 and its associated bearings 178, 179 and driver in the form of a sprocket 180 driven by a looped transmission member in the form of a chain 190.

[0074] Referring again to figure 7c, the strip 10 enters the gap 10A between the rollers 175 and 170. Pinch roller 170 opposes the pinch roller 175 and acts on the opposite side of the strip 10 to the roller 175. The drive roller 175 frictionally engages with the base of the strip 10 and is driven by a sprocket 180.

[0075] The size and configuration of the gap 10A and the outer pinch roller 170 can both be varied to suit the strip being wound.

[0076] The pinch roller 175 is cantilevered out from the bearings into the pipe 9 being wound. The pinch roller 170 is mounted to the drive tray body 165 as illustrated in Figure 7c. With conventional winding cages, the proximal frame 200 is located well away from the sprocket 180 and associated drive tray body zone 165 illustrated in Figure 7c. This can be seen by referring to Figure 2a in which the primary frame 61 is spaced outboard of the drive tray 80 and a long distance from the secondary frame 62. With the arrangement shown in Figure 2a, it can be seen that the rollers 70 are long compared to the rollers 130 of the embodiment of the invention illustrated in Figure 8.

[0077] The shorter rollers 130 of the embodiment of the invention illustrated in Figure 8 can have a smaller diameter due to their reduced span. That is, for the same design load, the rollers 130 of the embodiment of the invention shown in Figure 8 can have a significantly smaller diameter than the required diameter of the roller 70 of the winding cage shown in Figure 2a. This is a significant advantage in that it allows the overall diameter to the winding cage 110 to be reduced.

[0078] A further feature that facilitates a reduction in the diameter of the cage 110 is shown in Figure 11. The arrangement includes a shaft 350 that extends from the proximal frame 200 to the distal frame 270. In the embodiment shown, the shaft 350 is fixed (it does not rotate). The shaft 350 is offset in a radial inwards direction when compared to the roller 140 and the remaining rollers 130 as illustrated in Figure 8. This radial offset allows a larger diameter roller 150 rotating about an axis 150A and having a surface 150E to be provided without increasing the overall outside diameter of the winding cage 110 (the axis 150A is radially inboard of the axes of rollers 130). At the same time, the roller 150 is of sufficient diameter such that its surface 150E engages the crowns 38 and 39 of the female locking portions 35 and 36.

[0079] Figure 11 also illustrates how the strip 10 is guided and stabilised in a direction lateral to the strip or longitudinal to the pipe. Specifically, Figure 11 shows rollers 616 and 626. These rollers rotate about shafts having axes that are substantially perpendicular to the base 12 of the strip 10. The rollers 616 and 626 are compact and, importantly, do not add to the overall outer diameter of the winding cage 110. The direction of rotation of the rollers 616 and 626 varies depending on whether they are supporting the strip 10 against a lateral load one way or the other. Having separate rollers 616 and 626 performing different functions provides additional design flexibility as compared to earlier arrangements where a large single roller 75 having ribs 76 was previously employed such as is shown in Figure 2a.

[0080] Figure 14 is a similar illustration to that of Figure 11, but illustrates an alternative strip guiding arrangement. Figure 14 shows roller 630. This roller rotates about an axis 639. Figure 13 shows a plurality of rib support rollers 630 circumferentially spaced around the longitudinal winding cage axis 111. The rib support roller axes 639 are spaced from the longitudinal winding cage axis 111 at a second radius  $R_2$ . The second radius  $R_2$  is smaller than the first radius  $R_1$  ( $R_2 < R_1$ ).

[0081] Figure 15 is a diagrammatic end view of the winding cage of Figure 13 and shows a rib support rollers, the rib support roller having a rib support roller axis. In practice there will be a number (3 or 4 for instance) of rib support rollers each having an axis. As stated above and as is also shown in figure 13, the rib support axes are spaced around the longitudinal winding cage axis at a second radius  $R_2$ , and the second radius is smaller than the first radius  $R_1$ . The smaller second radius  $R_2$  provides a significant advantage. It allows a flanged roller to be used without increasing the overall diameter of the winding cage (in contrast to the arrangement shown in Figure 2a).

[0082] Each rib support roller 630 has a plurality of flanges 638, the flanges 638 engaging the ribs 20 of the strip 10, thereby laterally guiding the strip 10.

**[0083]** The winding machine and winding cage described above with reference to the drawings provides many advantages as compared to earlier winding machines and winding cages. A number of those advantages have been explained above and some further advantages are that the cage 110 becomes smaller and is therefore able to be manoeuvred more easily below ground. This is particularly useful where access is tight and where there are direction changes from an access hole.

**[0084]** Throughout the specification and the claims that follow, unless the context requires otherwise, the words “comprise” and “include” and variations such as “comprising” and “including” will be understood to imply the inclusion of a stated integer or group of integers, but not the exclusion of any other integer or group of integers.

**[0085]** The reference to any prior art in this specification is not, and should not be taken as, an acknowledgement of any form of suggestion that such prior art forms part of the common general knowledge.

**[0086]** It will be appreciated by those skilled in the art that the invention is not restricted in its use to the particular application described. Neither is the present invention restricted in its preferred embodiment with regard to the particular elements and/or features described or depicted herein. It will be appreciated that the invention is not limited to the embodiment or embodiments disclosed, but is capable of numerous rearrangements, modifications and substitutions without departing from the scope of the invention as set forth and defined by the following claims.

**CLAIMS**

1. A winding cage for winding a helically wound pipe from an elongate ribbed strip having at least one rib and having opposed joinable edge portions, the winding cage forming a guide for the helically wound pipe, the winding cage including:

a plurality of spaced apart strip guide rollers, each strip guide roller having a proximal end and a distal end, the strip guide rollers spaced around a longitudinal winding cage axis;

a proximal support frame having a plurality of guide roller proximal end supports for supporting the proximal ends of the strip guide rollers;

a distal support frame having a plurality of guide roller distal end supports for supporting the distal ends of the strip guide rollers, the proximal and distal support frames spaced apart from each other and together supporting the plurality of spaced apart strip guide rollers;

a proximal frame bridge, the bridge extending away from the proximal frame and bridging between spaced apart first and second ends of the proximal support frame; and

a proximal mount on the bridge and a distal mount on the distal support frame, the proximal and distal mounts for receiving a strip driver assembly, the strip driver assembly for driving the strip into the winding cage,

whereby the bridge forms part of a mouth opening into the winding cage, the mouth for accommodating the strip driver assembly.

2. The cage as claimed in claim 1 wherein the mouth has a width greater than a length of a longest of the plurality of spaced apart strip guide rollers.

3. The winding cage as claimed in claim 1 including at least one rib support roller, the at least one rib support roller extending radially inwards from a shaft extending between the proximal and distal support frames, whereby, in use, the rib support roller engages at least one rib of the strip, thereby laterally guiding the strip.

4. The winding cage as claimed in the preceding claim wherein the at least one rib support roller includes at least one flange, in use the flange engaging the at least one rib of the strip, thereby laterally guiding the strip.

5. The winding cage as claimed in claim 4

wherein each strip guide roller is rotatable about a strip guide roller axis, the strip guide roller axes at a first radius spaced around the longitudinal winding cage axis and

wherein the at least one rib support roller is rotatable around a rib support roller axis, the rib support roller axis spaced from the longitudinal winding cage axis at a second radius, the second radius smaller than

the first radius.

6. The winding cage as claimed in claim 4 including a rib support roller, the rib support roller mounted to rotate about an axis that extends radially inwards from a shaft extending between the proximal and distal support frames,

whereby, in use, the rib support roller engages at least one rib of the strip, thereby laterally guiding the strip.

7. A winding cage for winding a helically wound pipe from an elongate ribbed strip having at least one rib and having opposed joinable edge portions, the winding cage forming a guide for the helically wound pipe, the winding cage including:

a plurality of spaced apart strip guide rollers, each strip guide roller having a proximal end, a distal end and a strip guide roller axis, the strip guide rollers axes spaced around a longitudinal winding cage axis at a first radius, the strip guide rollers having a strip roller maximum radius;

a proximal support frame having a plurality of proximal guide roller supports for supporting the proximal ends of the strip guide rollers;

a distal support frame having a plurality of distal guide roller supports for supporting the distal ends of the strip guide rollers, the proximal and distal support frames spaced apart from each other and together supporting the plurality of spaced apart strip guide rollers; and

a plurality of rib support rollers, each rib support roller having a rib support roller axis, the rib support axes spaced around the longitudinal winding cage axis at a second radius, the second radius smaller than the first radius.

8. The winding cage as claimed in the preceding claim wherein the at least one rib support roller includes at least one flange, in use the flange engaging the at least one rib of the strip, thereby laterally guiding the strip.

9. The winding cage as claimed in claim 7 wherein the rib support roller is mounted to rotate about an axis that extends radially inwards from a shaft extending between the proximal and distal support frames.

10. A winding machine for winding a helically wound pipe from an elongate ribbed strip having at least one rib and having opposed joinable edge portions, the winding machine including a winding cage and a powered strip driver assembly for driving the strip into the winding cage, the winding cage forming a guide for the helically wound pipe, the winding cage including:

a plurality of spaced apart strip guide rollers, each strip guide roller having a proximal end and a distal end, the strip guide rollers spaced around a longitudinal winding cage axis;

a proximal support frame having a plurality of guide roller proximal end supports for supporting the proximal ends of the strip guide rollers; and

a distal support frame having a plurality of guide roller distal end supports for supporting the distal ends of the strip guide rollers, the proximal and distal support frames spaced apart from each other and together supporting the plurality of spaced apart strip guide rollers,

wherein the proximal support frame includes a first end and a second end, the first and second ends spaced apart so as to provide an opening for accommodating the strip driver assembly.

11. The winding machine as claimed in claim 10 wherein the proximal support frame is shaped to describe part of an annulus between the spaced apart ends.

12. The winding machine as claimed in claim 10 wherein the spaced apart ends of the proximal support frame form part of a mouth, the mouth having a width greater than a length of a longest of the plurality of spaced apart strip guide rollers.

13. The winding machine as claimed in claim 10 including a proximal frame bridge, the bridge bridging between the spaced apart first and second ends of the proximal support frame,  
whereby the bridge forms part of the mouth, the mouth for accommodating the strip driver assembly.

14. The winding machine as claimed in the preceding claim wherein the bridge includes a mount, the mount connecting the strip driver assembly to the bridge and thereby to the proximal support frame.

15. The winding machine as claimed in claim 10 wherein the strip driver assembly includes a strip entrance and a strip exit and a pair of pinch rollers for driving the strip, the pinch rollers located adjacent to the strip exit, wherein the pinch rollers include a driver mounted around a pinch roller drive shaft,  
whereby the spaced apart ends of the annulus accommodate a portion of the strip driver assembly adjacent the driver.

16. The winding machine as claimed in the preceding claim wherein the driver includes a sprocket, the sprocket driven by a looped transmission member.

17. The winding machine as claimed in the preceding claim wherein the looped transmission member includes a chain.

18. The winding machine as claimed in the preceding claim wherein the looped transmission member includes a belt.

19. The winding machine as claimed in claim 10 including at least one rib support roller, the at least one rib support roller extending radially inwards from a shaft extending between the proximal and distal support frames, whereby, in use, the rib support roller engages at least one rib of the strip, thereby laterally guiding

the strip.

20. The winding machine as claimed in the preceding claim wherein the at least one rib support roller includes at least one flange, in use the flange engaging the at least one rib of the strip, thereby laterally guiding the strip.

21. The winding machine as claimed in the preceding claim wherein each strip guide roller is rotatable about a strip guide roller axis, the strip guide roller axes at a first radius spaced around the longitudinal winding cage axis; and wherein the at least one rib support roller is rotatable around a rib support roller axis, the rib support roller axis spaced from the longitudinal winding cage axis at a second radius, the second radius smaller than the first radius.

22. The winding machine as claimed in claim 10 including a rib support roller, the rib support roller mounted to rotate about an axis that extends radially inwards from a shaft extending between the proximal and distal support frames, whereby, in use, the rib support roller engages at least one rib of the strip, thereby laterally guiding the strip.

23. A winding machine for winding a helically wound pipe from an elongate ribbed strip having at least one rib and having opposed joinable edge portions, the winding machine including a winding cage and a powered strip driver assembly for driving the strip into the winding cage, the winding cage forming a guide for the helically wound pipe, the winding cage including:

a plurality of spaced apart strip guide rollers, each strip guide roller having a proximal end, a distal end and a strip guide roller axis, the strip guide rollers axes spaced around a longitudinal winding cage axis at a first radius, the strip guide rollers having a strip roller maximum radius;

a proximal support frame having a plurality of proximal guide roller supports for supporting the proximal ends of the strip guide rollers;

a distal support frame having a plurality of distal guide roller supports for supporting the distal ends of the strip guide rollers, the proximal and distal support frames spaced apart from each other and together supporting the plurality of spaced apart strip guide rollers; and

a plurality of rib support rollers, each rib support roller having a rib support roller axis, the rib support axes spaced around the longitudinal winding cage axis at a second radius, the second radius smaller than the first radius.

24. The winding machine as claimed in the preceding claim wherein the at least one rib support roller includes at least one flange, in use the flange engaging the at least one rib of the strip, thereby laterally

guiding the strip.

The winding machine as claimed in the preceding claim wherein the rib support roller is mounted to rotate about an axis that extends radially inwards from a shaft extending between the proximal and distal support frames.

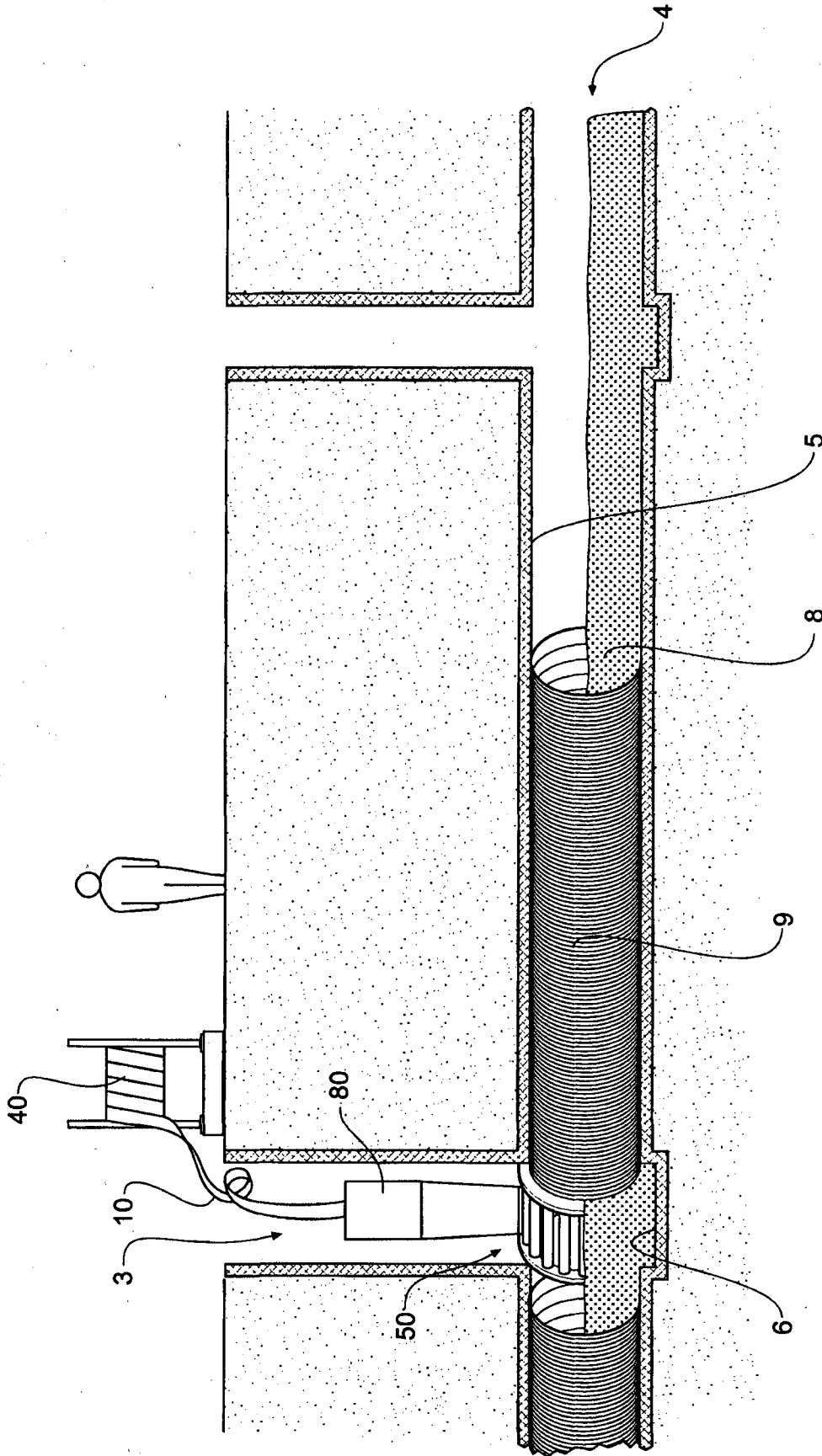

**Figure 1**  
Prior Art

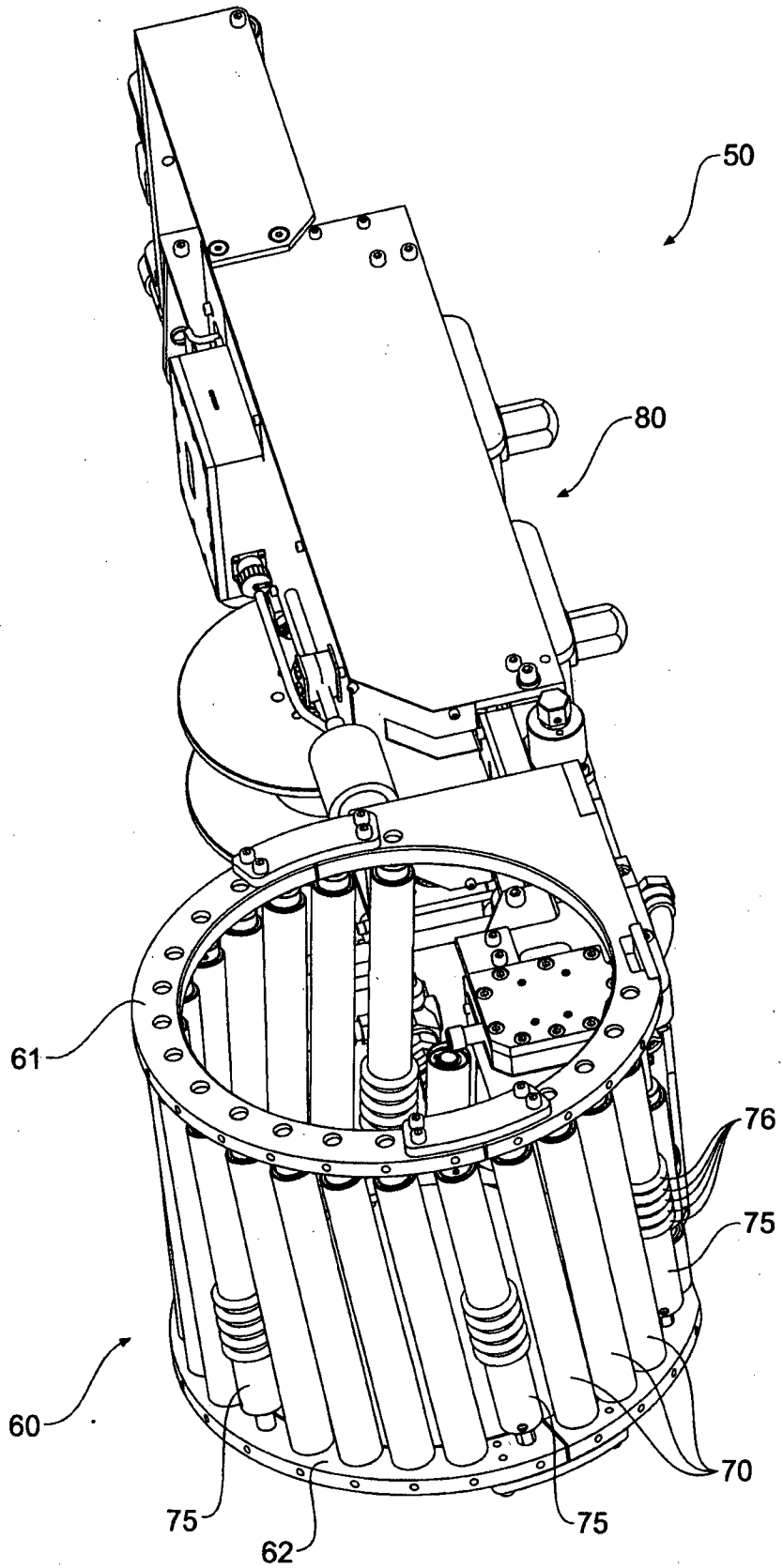

**Figure 2a**

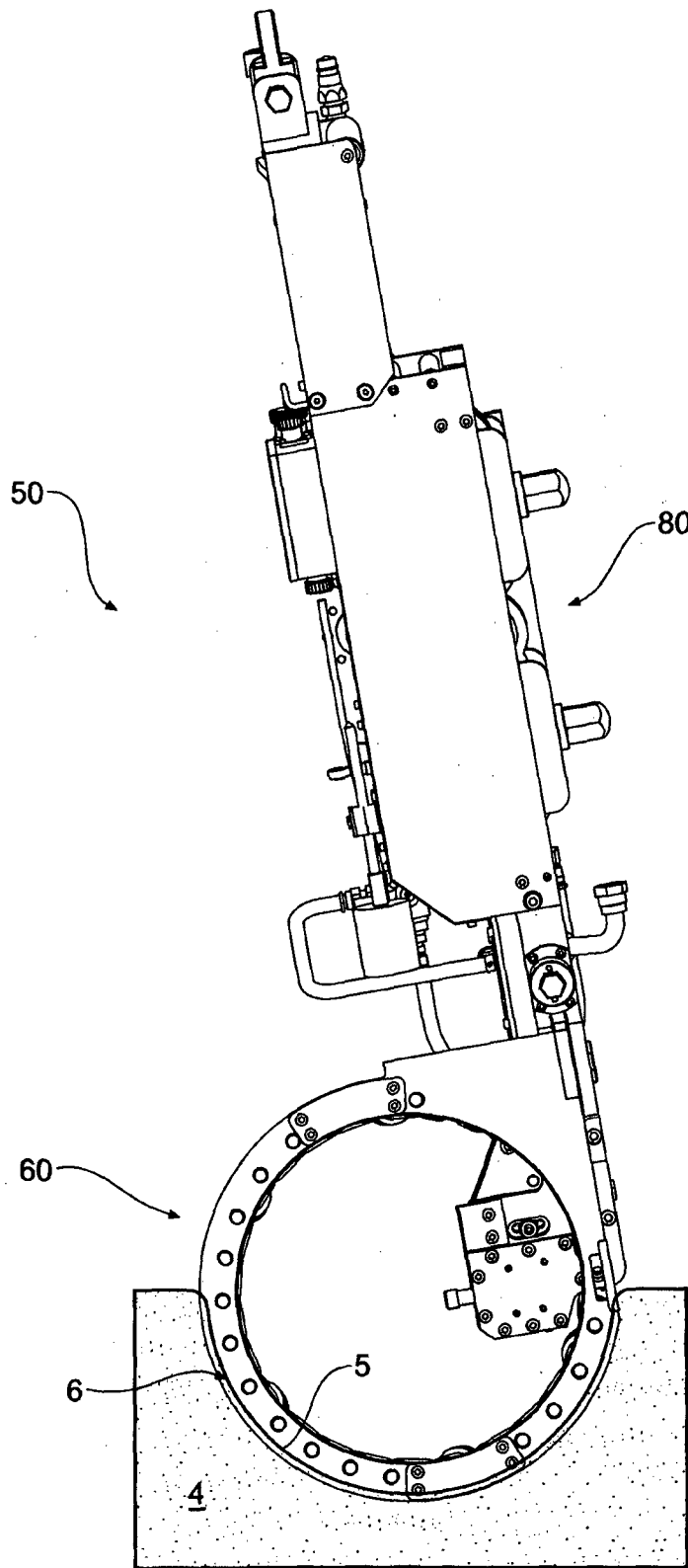

**Figure 2b**

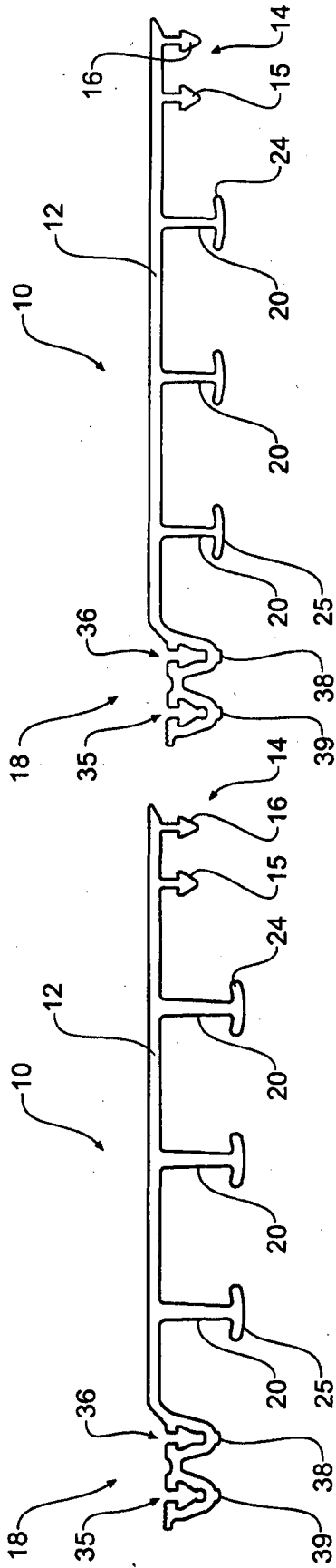

Figure 3a

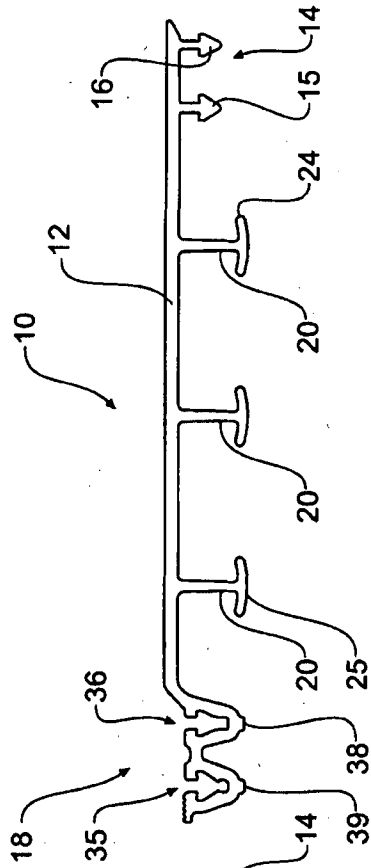

Figure 3b

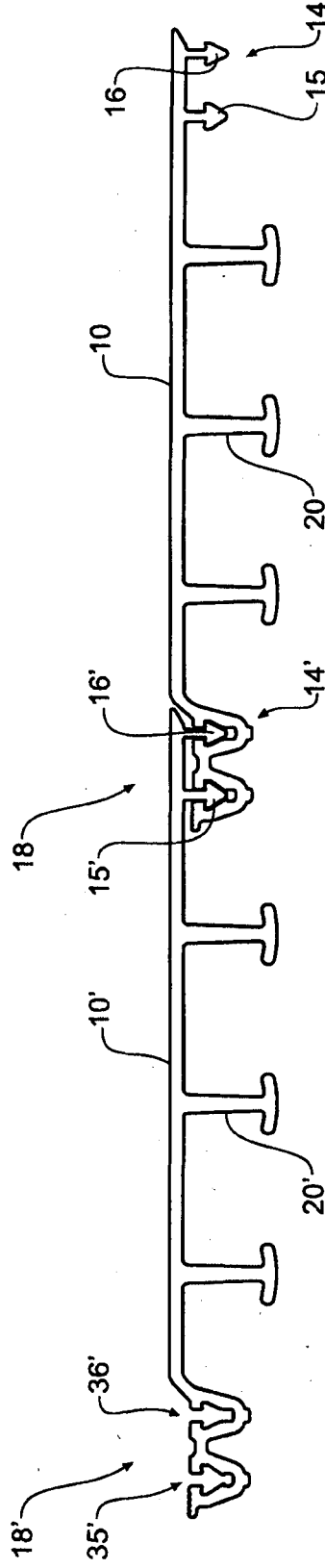

Figure 3c

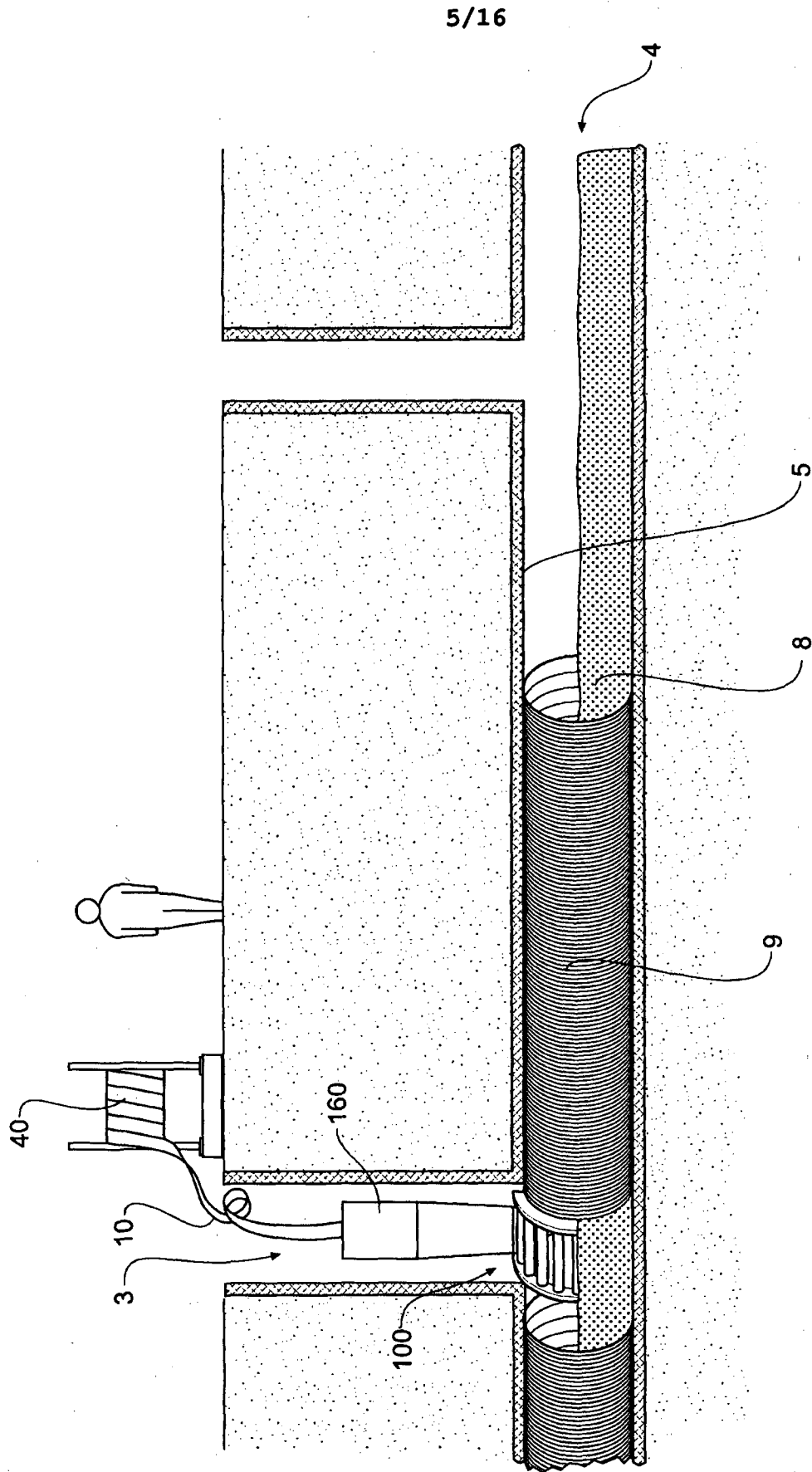

Figure 4

6/16

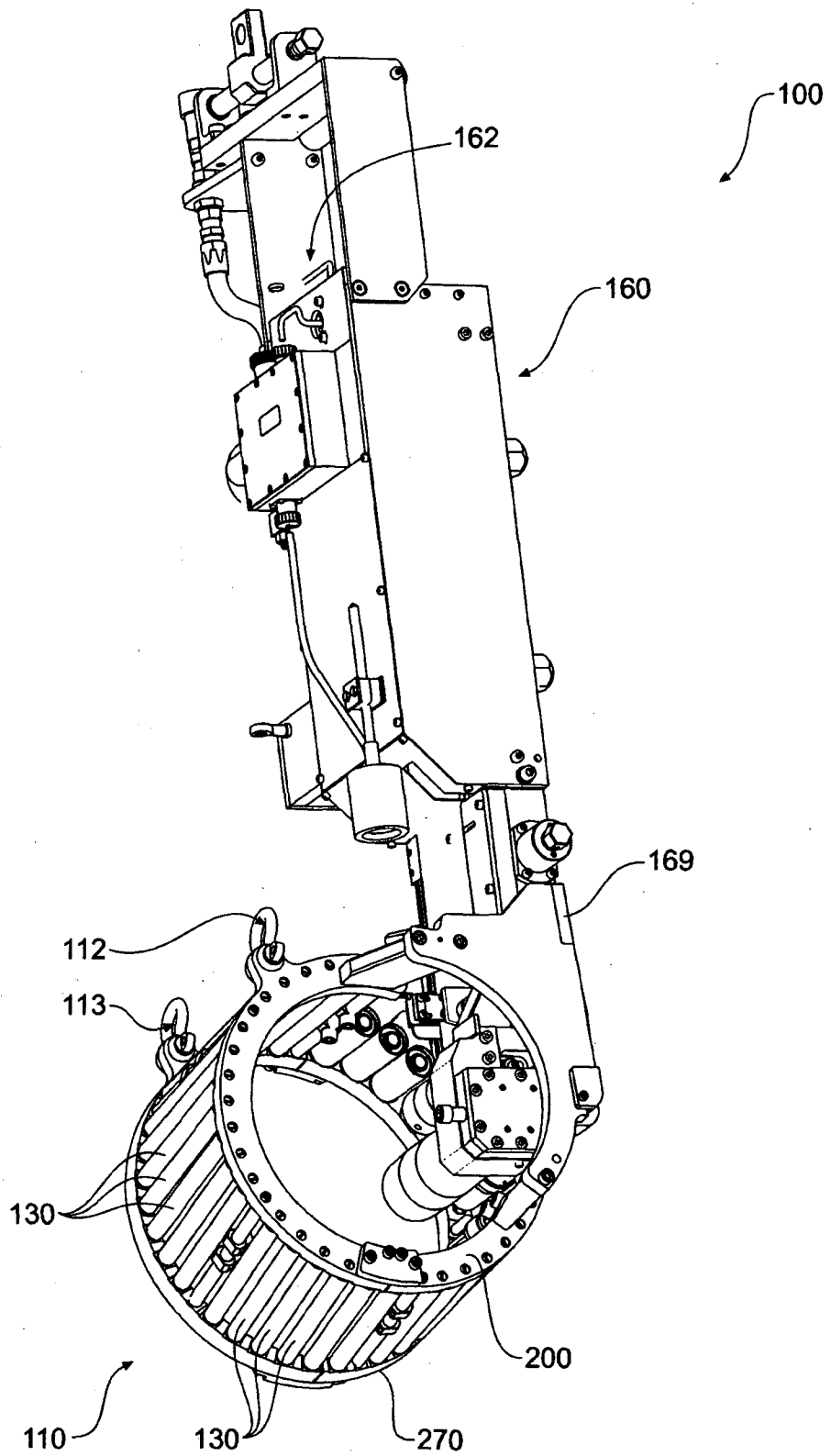
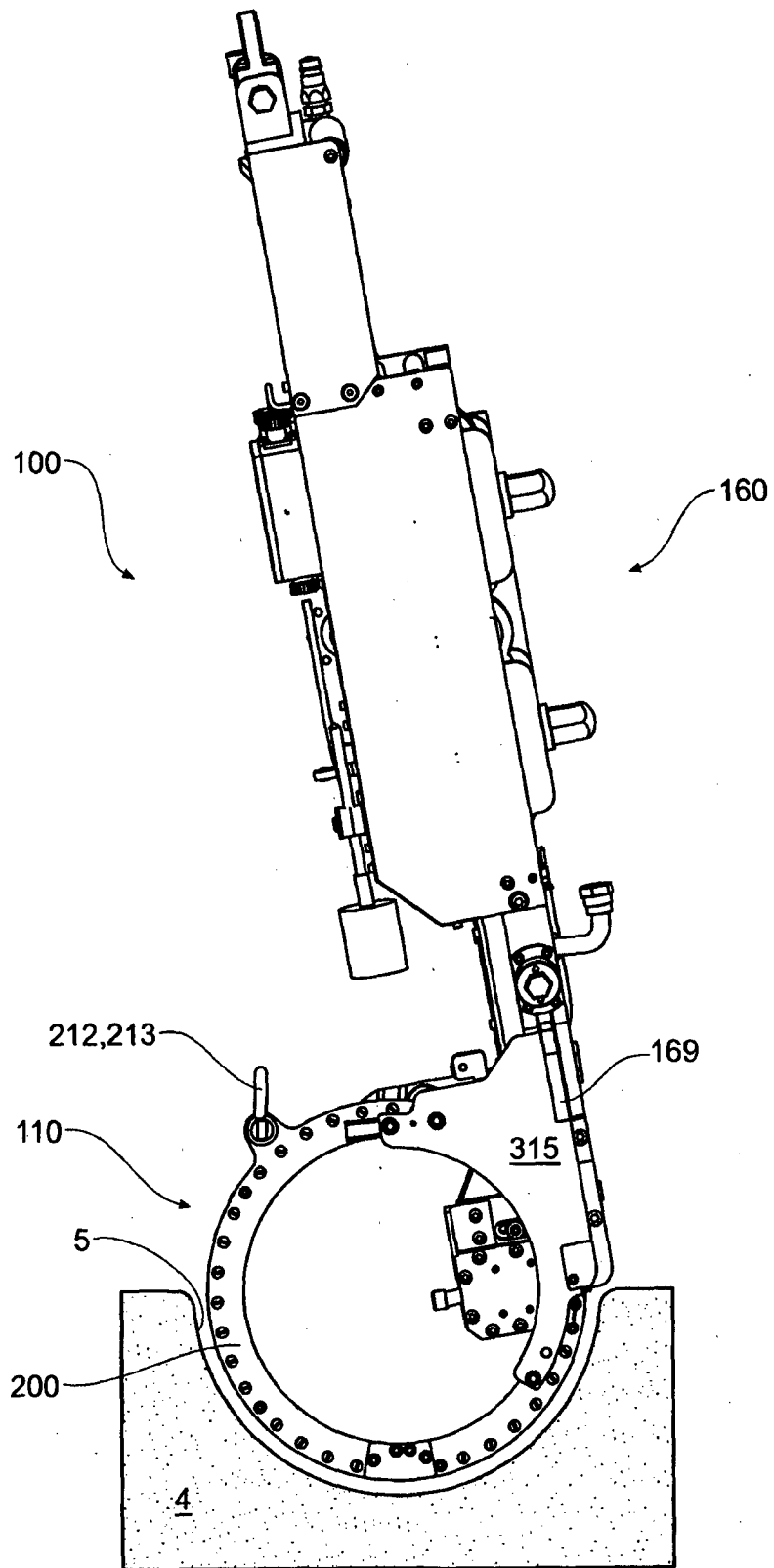

Figure 5

7/16



**Figure 6**

8/16

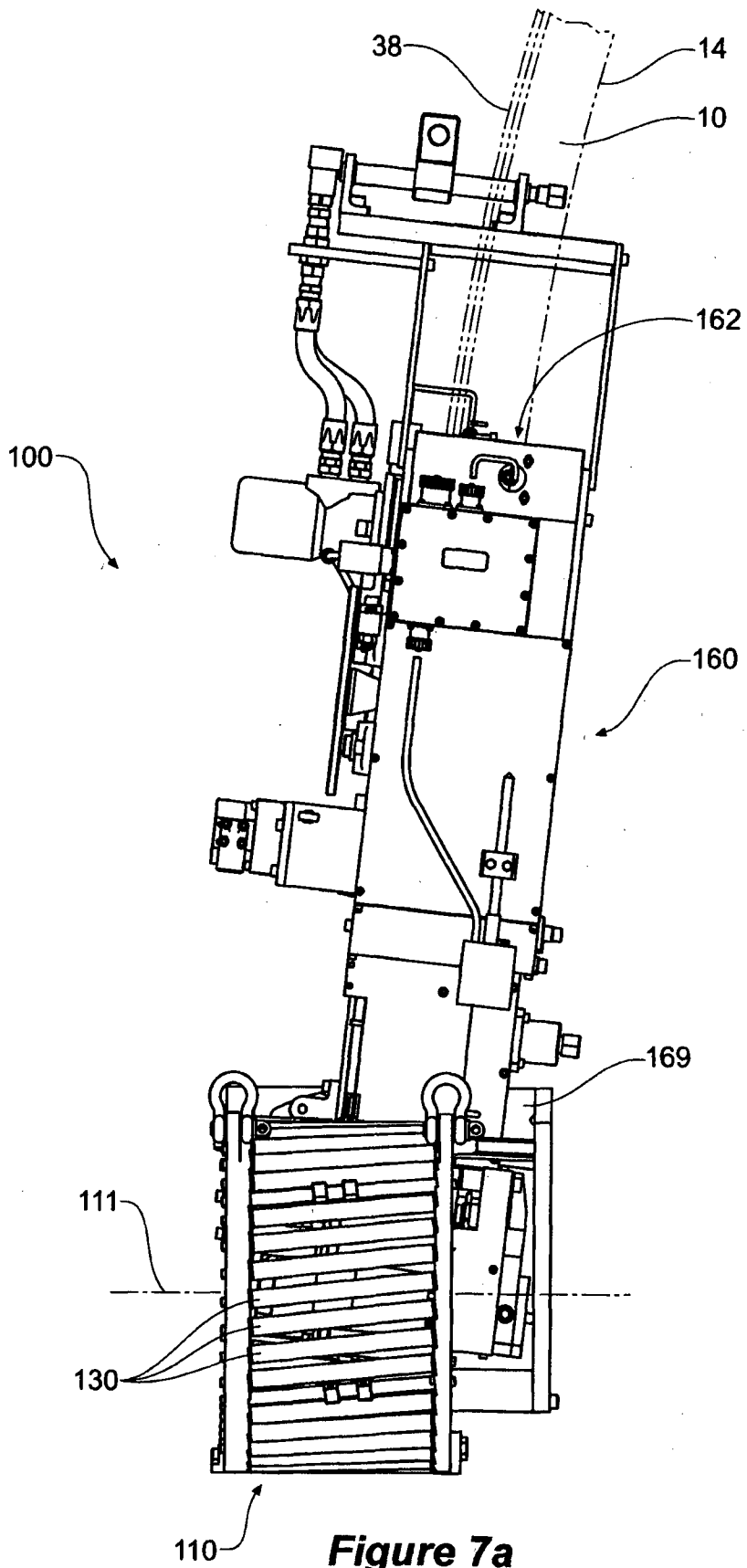

Figure 7a

9/16

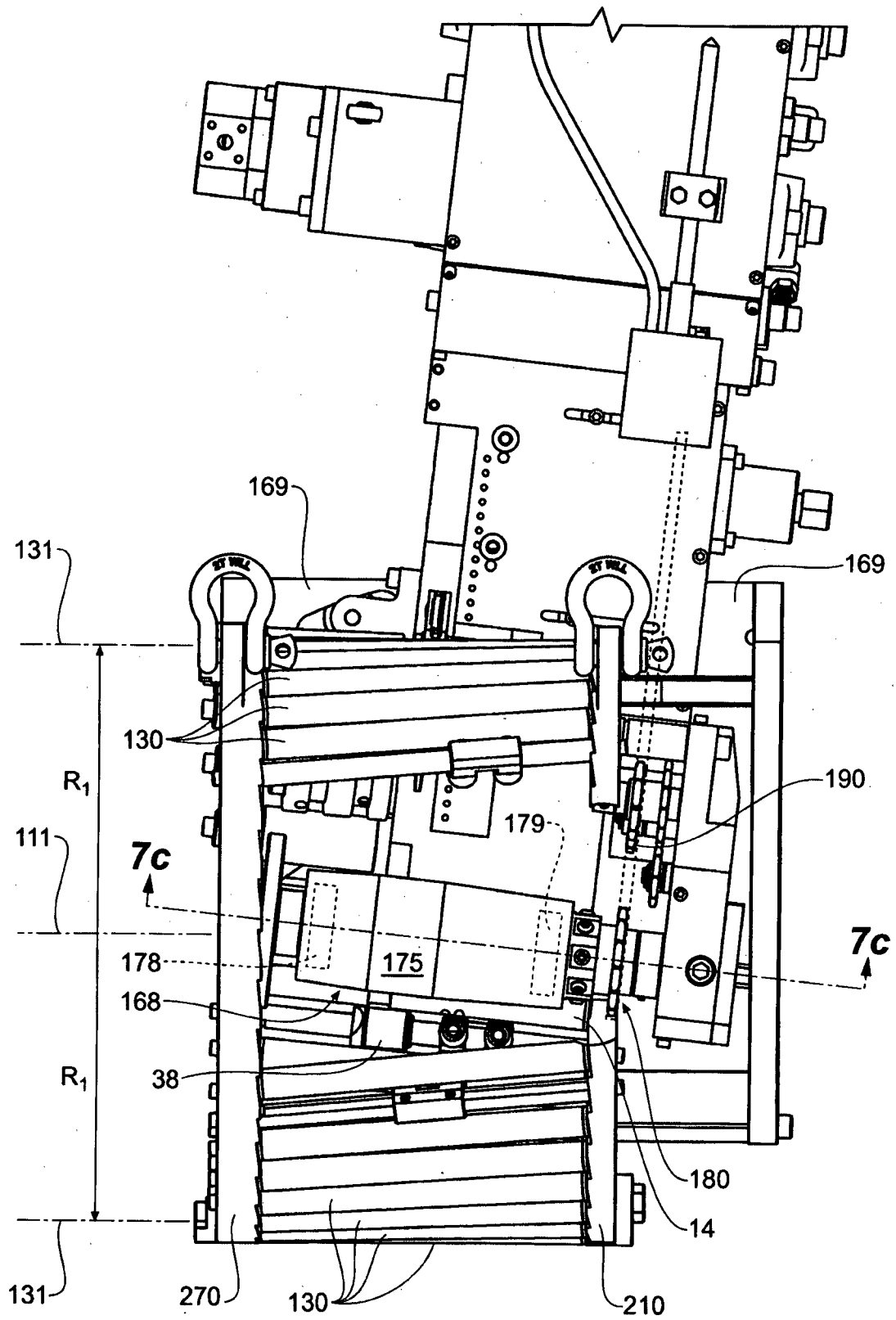

Figure 7b

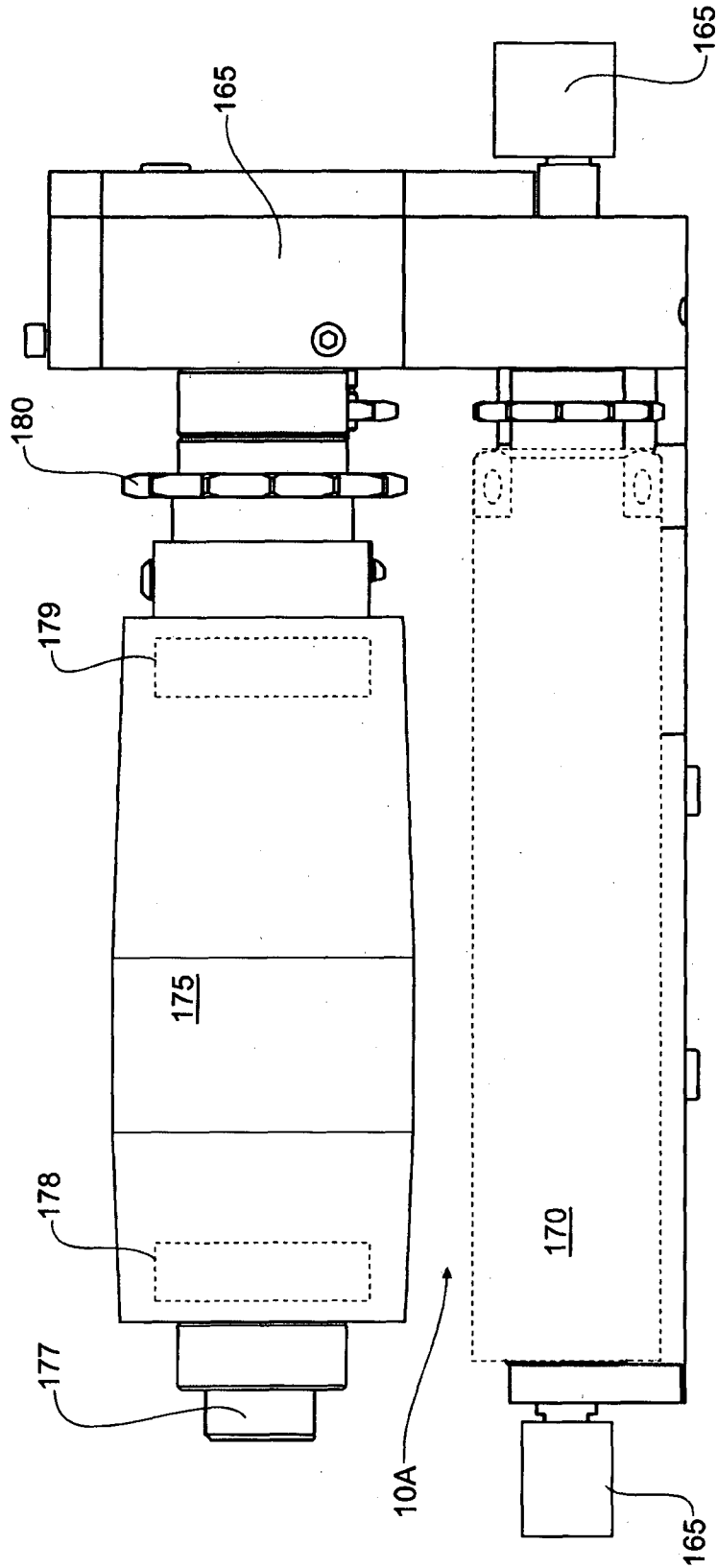
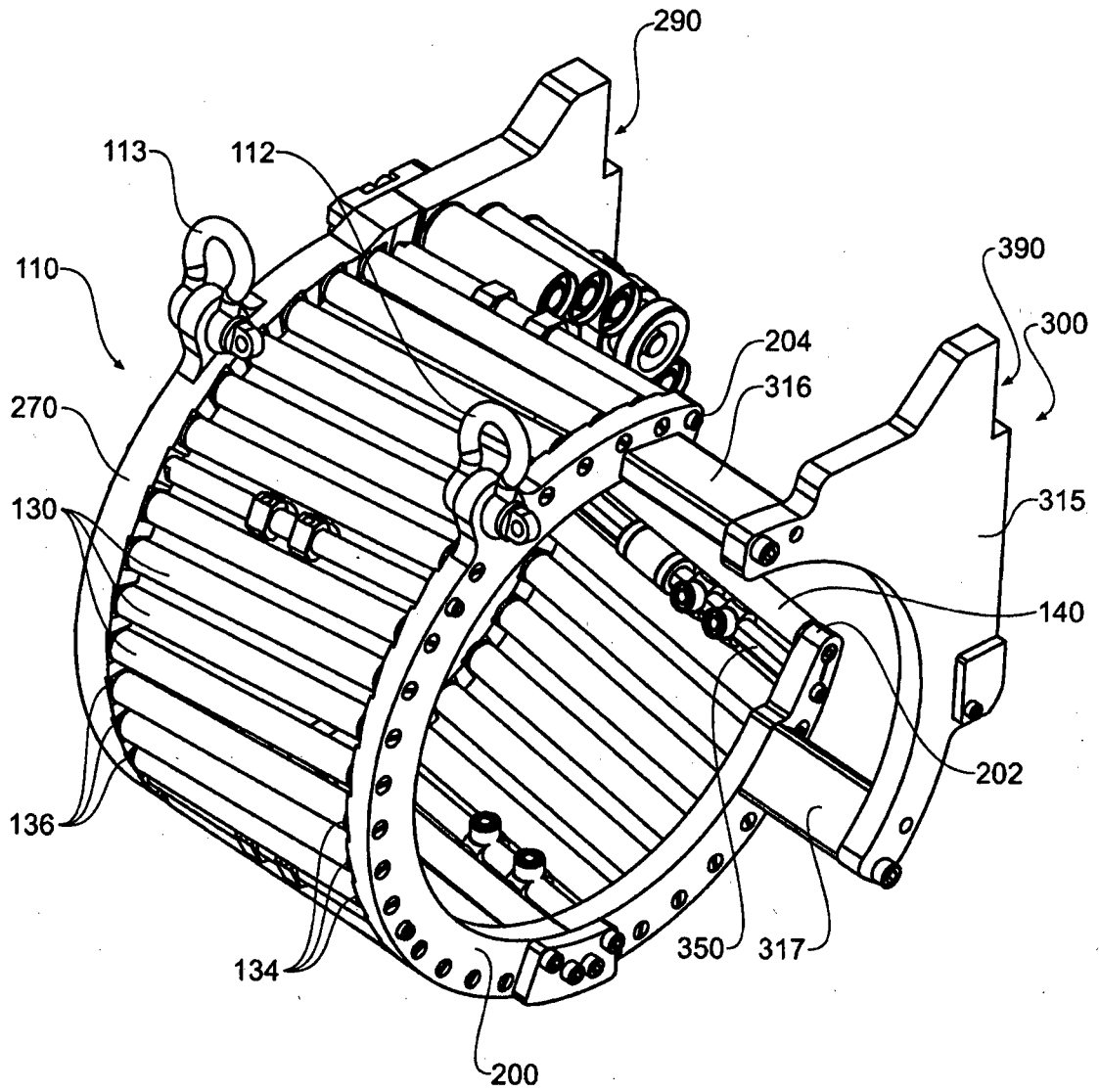
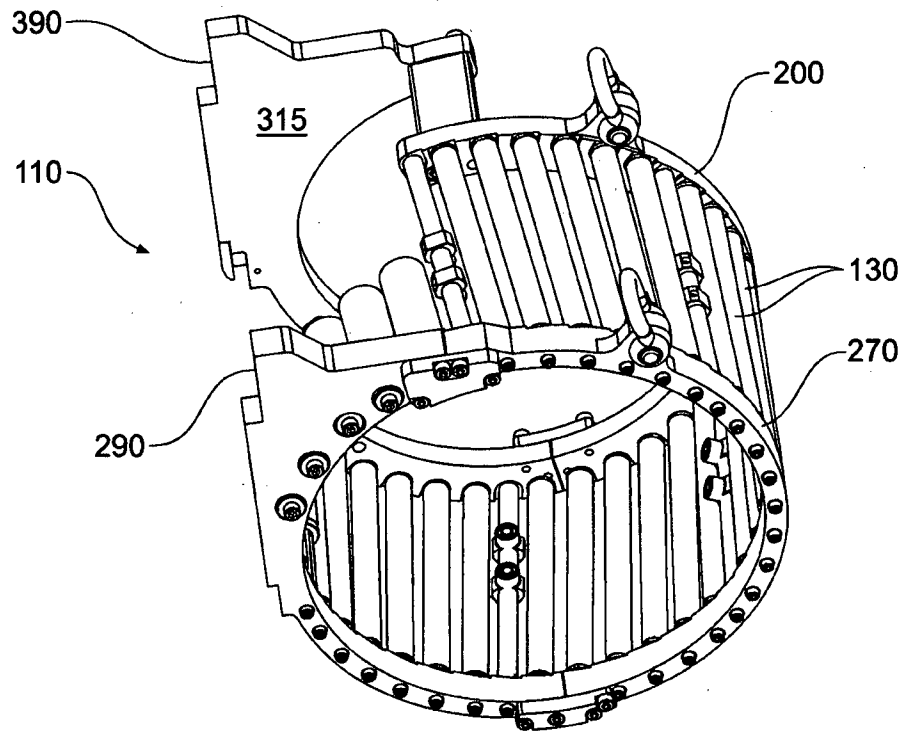

Figure 7c

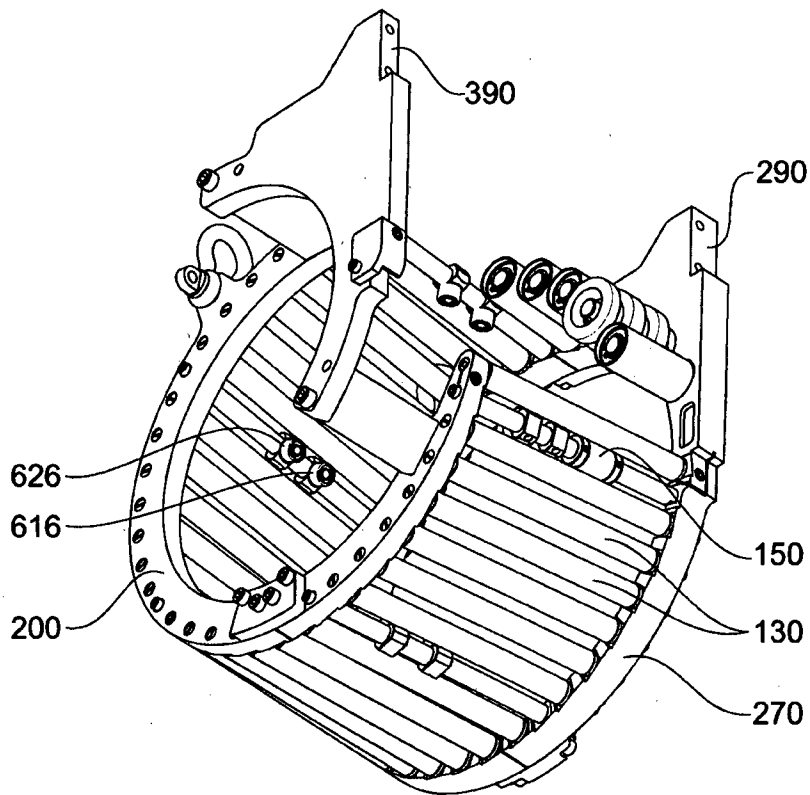

**Figure 8**

12/16



**Figure 9**



**Figure 10**

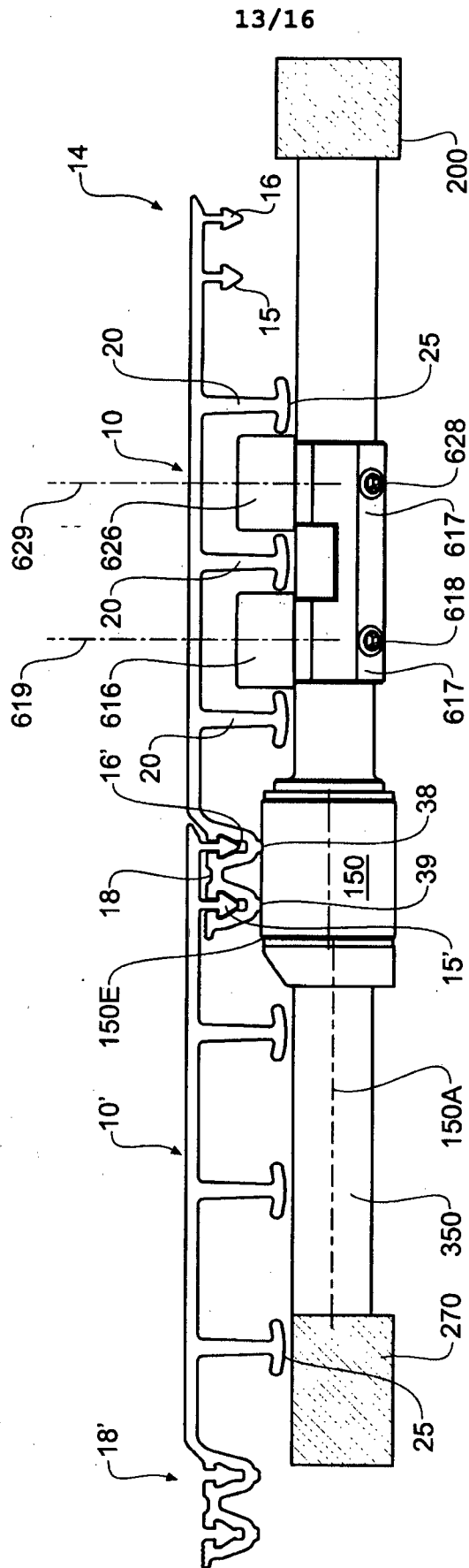
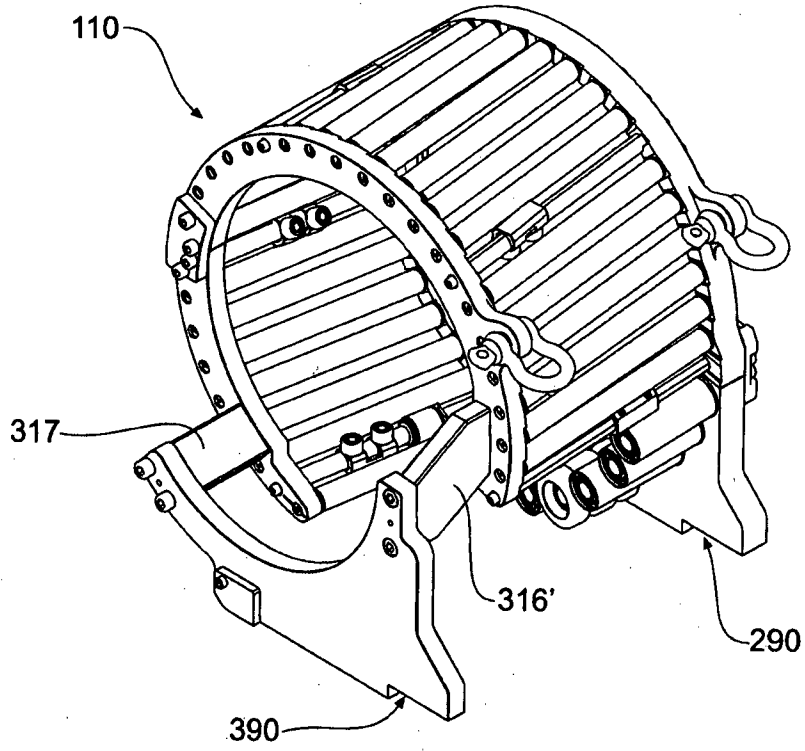
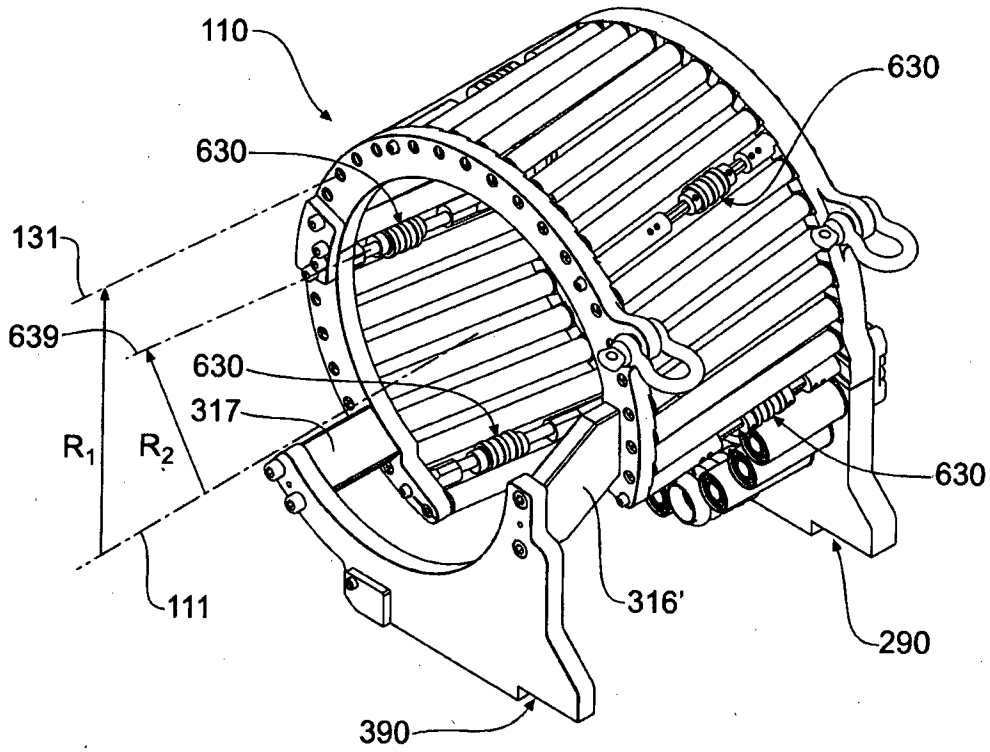

Figure 11

14/16



**Figure 12**



**Figure 13**

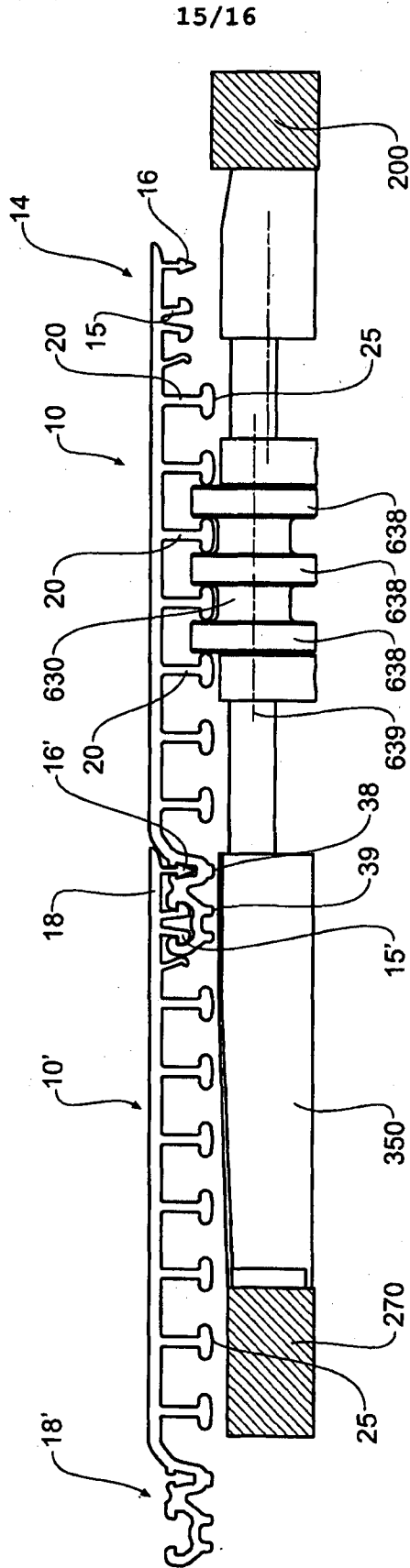
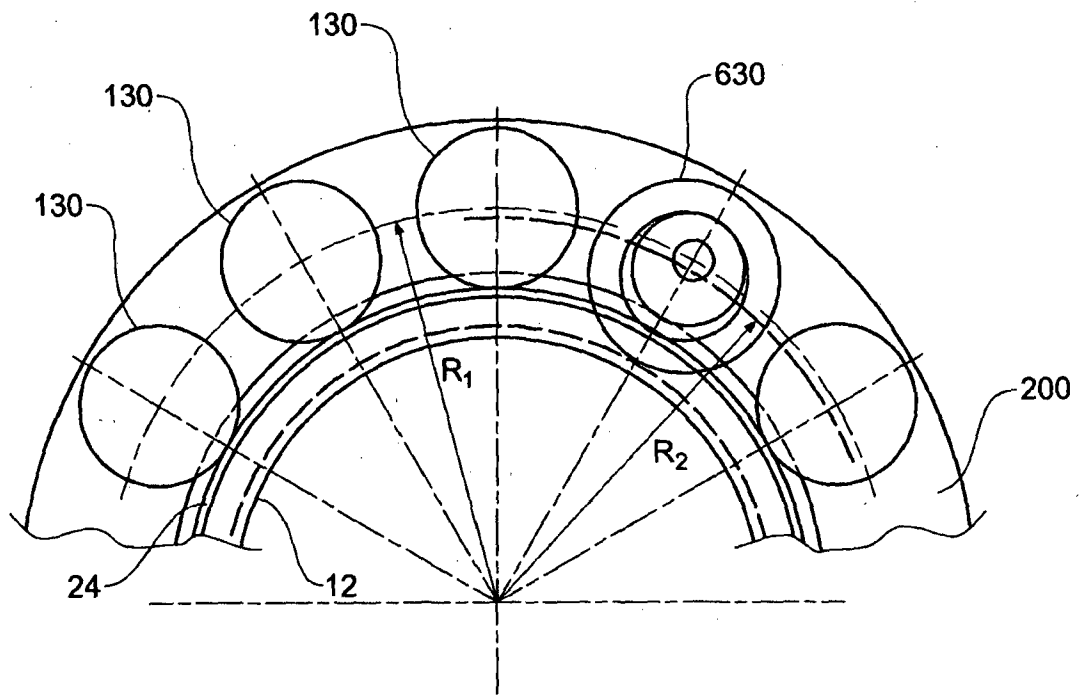

Figure 14



**Figure 15**

## INTERNATIONAL SEARCH REPORT

International application No.

PCT/AU2013/000301

## A. CLASSIFICATION OF SUBJECT MATTER

**B29C 63/32 (2006.01) B29C 53/78 (2006.01) F16L 55/18 (2006.01) F16L 55/162 (2006.01)**

According to International Patent Classification (IPC) or to both national classification and IPC

## B. FIELDS SEARCHED

Minimum documentation searched (classification system followed by classification symbols)

Documentation searched other than minimum documentation to the extent that such documents are included in the fields searched

Electronic data base consulted during the international search (name of data base and, where practicable, search terms used)

WPI &amp; EPODOC: IPC/CC - B29C53, B29C55, B29C63/26, B29C65, F16L1, F16L55, B29V66, B29D23 &amp; Keywords - pipe, conduit, tunnel, winding, cage, head, strip, profile, support, helical, spiral and similar terms.

## C. DOCUMENTS CONSIDERED TO BE RELEVANT

Category*	Citation of document, with indication, where appropriate, of the relevant passages	Relevant to claim No.
	Documents are listed in the continuation of Box C	

 Further documents are listed in the continuation of Box C See patent family annex

* Special categories of cited documents:		
"A" document defining the general state of the art which is not considered to be of particular relevance	"T"	later document published after the international filing date or priority date and not in conflict with the application but cited to understand the principle or theory underlying the invention
"E" earlier application or patent but published on or after the international filing date	"X"	document of particular relevance; the claimed invention cannot be considered novel or cannot be considered to involve an inventive step when the document is taken alone
"L" document which may throw doubts on priority claim(s) or which is cited to establish the publication date of another citation or other special reason (as specified)	"Y"	document of particular relevance; the claimed invention cannot be considered to involve an inventive step when the document is combined with one or more other documents, such combination being obvious to a person skilled in the art
"O" document referring to an oral disclosure, use, exhibition or other means	"&"	document member of the same patent family
"P" document published prior to the international filing date but later than the priority date claimed		

Date of the actual completion of the international search  
7 June 2013Date of mailing of the international search report  
07 June 2013

## Name and mailing address of the ISA/AU

AUSTRALIAN PATENT OFFICE  
PO BOX 200, WODEN ACT 2606, AUSTRALIA  
Email address: pct@ipaustalia.gov.au  
Facsimile No.: +61 2 6283 7999

## Authorised officer

Maruli Saputra  
AUSTRALIAN PATENT OFFICE  
(ISO 9001 Quality Certified Service)  
Telephone No. 0399359626

**INTERNATIONAL SEARCH REPORT**

International application No.

C (Continuation).

DOCUMENTS CONSIDERED TO BE RELEVANT

**PCT/AU2013/000301**

Category*	Citation of document, with indication, where appropriate, of the relevant passages	Relevant to claim No.
A	WO 1983/004196 A1 (RIB LOC HONG KONG LIMITED) 08 December 1983 Abstract, pages 3-4, 8-14, figures 7-11	1-25
A	WO 1998/034742 A1 (RIB LOC AUSTRALIA PTY LTD) 13 August 1998 Abstract, figures 2-6	1-25
A	US 5108283 A (SHAW, K.J. et al.) 28 April 1992 Abstract, figures 1-2	1-25
A	US 4995929 A (MENZEL, S.W.O.) 26 February 1991 Abstract, figures 1, 6, 11-13	1-25

**Box No. II Observations where certain claims were found unsearchable (Continuation of item 2 of first sheet)**

This international search report has not been established in respect of certain claims under Article 17(2)(a) for the following reasons:

1.  Claims Nos.:  
because they relate to subject matter not required to be searched by this Authority, namely:
  
2.  Claims Nos.:  
because they relate to parts of the international application that do not comply with the prescribed requirements to such an extent that no meaningful international search can be carried out, specifically:
  
3.  Claims Nos.:  
because they are dependent claims and are not drafted in accordance with the second and third sentences of Rule 6.4(a)

**Box No. III Observations where unity of invention is lacking (Continuation of item 3 of first sheet)**

This International Searching Authority found multiple inventions in this international application, as follows:

**See Supplemental Box for Details**

1.  As all required additional search fees were timely paid by the applicant, this international search report covers all searchable claims.
2.  As all searchable claims could be searched without effort justifying additional fees, this Authority did not invite payment of additional fees.
3.  As only some of the required additional search fees were timely paid by the applicant, this international search report covers only those claims for which fees were paid, specifically claims Nos.:
  
4.  No required additional search fees were timely paid by the applicant. Consequently, this international search report is restricted to the invention first mentioned in the claims; it is covered by claims Nos.:

**Remark on Protest**

- The additional search fees were accompanied by the applicant's protest and, where applicable, the payment of a protest fee.
- The additional search fees were accompanied by the applicant's protest but the applicable protest fee was not paid within the time limit specified in the invitation.
- No protest accompanied the payment of additional search fees.

**Supplemental Box****Continuation of: Box III**

This International Application does not comply with the requirements of unity of invention because it does not relate to one invention or to a group of inventions so linked as to form a single general inventive concept.

This Authority has found that there are different inventions based on the following features that separate the claims into distinct groups:

- Claims 1-6 are directed to a winding cage. Claims 10-22 are directed to a winding machine. The feature of having a proximal frame bridge, proximal mount on the bridge and a distal mount on a distal support frame for receiving a strip driver assembly, whereby the bridge forms part of a mouth opening into the winding cage to accommodate the strip driver assembly is specific to this group of claims.
- Claims 7-9 are directed to a winding cage. Claims 23-25 are directed to a winding machine. The feature of a plurality of rib support rollers, each rib support roller having a rib support roller axis, the rib support axes spaced around the longitudinal winding cage axis at a second radius, the second radius smaller than the first radius is specific to this group of claims.

PCT Rule 13.2, first sentence, states that unity of invention is only fulfilled when there is a technical relationship among the claimed inventions involving one or more of the same or corresponding special technical features. PCT Rule 13.2, second sentence, defines a special technical feature as a feature which makes a contribution over the prior art.

When there is no special technical feature common to all the claimed inventions there is no unity of invention.

In the above groups of claims, the identified features may have the potential to make a contribution over the prior art but are not common to all the claimed inventions and therefore cannot provide the required technical relationship. The only feature common to all of the claimed inventions and which provides a technical relationship among them is a plurality of spaced apart strip guide rollers, each strip guide roller having a proximal end and a distal end, the strip guide rollers spaced around a longitudinal winding cage axis, a proximal support frame having a plurality of guide roller proximal end supports for supporting the proximal ends of the strip guide rollers a distal support frame having a plurality of guide roller distal end supports for supporting the distal ends of the strip guide rollers, the proximal and distal support frames spaced apart from each other and together supporting the plurality of spaced apart strip guide rollers

However this feature does not make a contribution over the prior art because it is disclosed in:  
D1: WO 1983/004196 A1 (RIB LOC HONG KONG LIMITED) 08 December 1983.

D1 discloses a winding cage (*figure 1*) for winding a helically wound pipe from an elongate ribbed strip (*figure 12 item 15, figure 13 item 83*) having at least one rib and having opposed joinable edge portions (*figure 13 items 81-82*), the winding cage forming a guide for the helically wound pipe, the winding cage including:

- a plurality of spaced apart strip guide rollers (*figure 10 item 108, figures 7-9*), each strip guide roller having a proximal end and a distal end, the strip guide rollers spaced around a longitudinal winding cage axis (*figures 7-9, the rollers have two ends, proximal end and distal end*)

**Supplemental Box**

- a proximal support frame (*figure 7 item 51 - two parts, proximal and distal frame*) having a plurality of guide roller proximal end supports for supporting the proximal ends of the strip guide rollers (*figure 10 item 108, figure 7 item 49*)
- a distal support frame (*figure 7 item 51 - two parts, proximal and distal frame*) having a plurality of guide roller distal end supports for supporting the distal ends of the strip guide rollers, the proximal and distal support frames spaced apart from each other and together supporting the plurality of spaced apart strip guide rollers (*figures 7-8 item 77*).

Therefore in the light of this document this common feature cannot be a special technical feature. Therefore there is no special technical feature common to all the claimed inventions and the requirements for unity of invention are consequently not satisfied *a posteriori*.

**INTERNATIONAL SEARCH REPORT**

Information on patent family members

International application No.

**PCT/AU2013/000301**

This Annex lists known patent family members relating to the patent documents cited in the above-mentioned international search report. The Australian Patent Office is in no way liable for these particulars which are merely given for the purpose of information.

<b>Patent Document/s Cited in Search Report</b>		<b>Patent Family Member/s</b>	
<b>Publication Number</b>	<b>Publication Date</b>	<b>Publication Number</b>	<b>Publication Date</b>
WO 1983/004196 A1	08 Dec 1983	AU 562309 B2	04 Jun 1987
		AU 1556283 A	16 Dec 1983
		DK 33884 A	25 Jan 1984
		DK 159869 B	24 Dec 1990
		EG 16466 A	30 Dec 1990
		EP 0109413 A1	30 May 1984
		EP 0109413 B1	09 Nov 1988
		FI 840330 A	27 Jan 1984
		FI 85230 B	13 Dec 1991
		NO 840308 A	26 Jan 1984
		NO 162265 B	28 Aug 1989
		PH 21620 A	11 Dec 1987
		US 4616495 A	14 Oct 1986
		WO 8304196 A1	08 Dec 1983
WO 1998/034742 A1	13 Aug 1998	AU 5742298 A	26 Aug 1998
		TW 442378 B	23 Jun 2001
		WO 9834742 A1	13 Aug 1998
US 5108283 A	28 Apr 1992	CA 2007042 A1	05 Jul 1990
		EP 0377227 A2	11 Jul 1990
		EP 0377227 B1	01 May 1996
		EP 0381257 A2	08 Aug 1990
		FI 900036 A	06 Jul 1990
		HU T54558 A	28 Mar 1991
		HU 203699 B	30 Sep 1991
		NO 900029 A	06 Jul 1990
		PL 162283 B1	30 Sep 1993
		PT 92781 A	13 Sep 1991
		PT 92781 B	31 Jan 1996
		US 5108283 A	28 Apr 1992
		YU 249489 A	20 Oct 1993
		ZA 9000027 A	26 Sep 1990
US 4995929 A	26 Feb 1991	AU 595600 B2	05 Apr 1990
		AU 7204087 A	09 Oct 1987
		DK 602587 A	17 Nov 1987
		DK 168497 B1	05 Apr 1994

Due to data integration issues this family listing may not include 10 digit Australian applications filed since May 2001.

Form PCT/ISA/210 (Family Annex)(July 2009)

**INTERNATIONAL SEARCH REPORT**

Information on patent family members

International application No.

**PCT/AU2013/000301**

This Annex lists known patent family members relating to the patent documents cited in the above-mentioned international search report. The Australian Patent Office is in no way liable for these particulars which are merely given for the purpose of information.

<b>Patent Document/s Cited in Search Report</b>		<b>Patent Family Member/s</b>	
<b>Publication Number</b>	<b>Publication Date</b>	<b>Publication Number</b>	<b>Publication Date</b>
		EP 0262183 A1	06 Apr 1988
		EP 0262183 B1	22 Nov 1990
		FI 875033 A	13 Nov 1987
		FI 87396 B	15 Sep 1992
		GR 870455 A1	10 Jul 1987
		HK 112793 A	29 Oct 1993
		IN 167882 A1	05 Jan 1991
		JP S63503238 A	24 Nov 1988
		JP 2529320 B2	28 Aug 1996
		NO 874790 A	12 Jan 1988
		NO 175326 B	20 Jun 1994
		NZ 219615 A	29 Mar 1989
		PT 84520 A	01 Apr 1987
		PT 84520 B	10 Nov 1989
		TR 23936 A	21 Dec 1990
		US 4995929 A	26 Feb 1991
		WO 8705677 A1	24 Sep 1987
		ZA 8701966 A	07 Sep 1987

**End of Annex**

Due to data integration issues this family listing may not include 10 digit Australian applications filed since May 2001.

Form PCT/ISA/210 (Family Annex)(July 2009)