

*G. W. Fair,*

*Sand Screen.*

*No. 112,911.*

*Patented Mar. 21. 1871.*

*Fig. 1.*

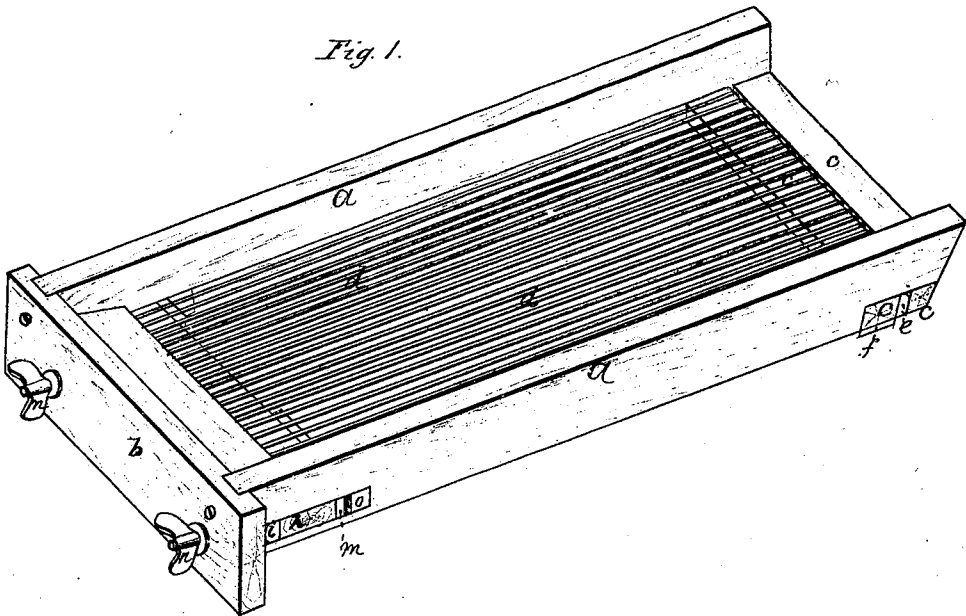

*Fig. 2.*

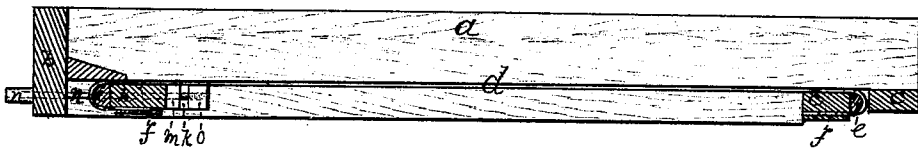

*Witnesses.*  
*H. J. Street*  
*G. C. Proun*

*Geo. W. Fair, Inventor.*  
*by Geo. C. Proun.*  
*his Attorney.*

# United States Patent Office.

GEORGE W. FAIR, OF DAYTON, OHIO

Letters Patent No. 112,911, dated March 21, 1871.

## IMPROVEMENT IN SAND-SCREENS.

The Schedule referred to in these Letters Patent and making part of the same.

I, GEORGE W. FAIR, of Dayton, in the county of Montgomery and State of Ohio, have invented certain Improvements in Screens for Cleansing Sand, Lime, &c., of which the following is a specification.

Figure 1 is a perspective view.

Figure 2, a sectional elevation.

This invention consists in the combination with a rectangular frame of wires stretched lengthwise of the same, and of a sliding head-block to which the wires are attached at their upper ends, and by moving which in the frame, by means of screws passing through said head-block, the wires may be tightened or loosened at pleasure.

In the drawing—

*a a* are the flaring side pieces;

*b* the upper cross-piece; and

*c c* the lower cross-pieces of the frame.

*d* are the wires which form the screen, the same being passed under a semi-cylindrical notched metal plate, *e*, that is situated between the two lower cross-pieces *c*, then bent upward and fastened at their lower ends between the cross-piece *c* and a metal plate, *f*, that is screwed upon the back of the same.

*h* is the head-block.

*i*, another semi-cylindrical notched plate, that is fastened upon the upper side of the head-block *h*, over which plate the wires *d* are led and then bent downward and fastened, at their upper ends, between the head-block *h* and another metal plate, *f*, screwed upon the back of the same.

The head-block enters slots, *k*, made lengthwise in the upper end of the side pieces *a*.

Within the slots *k*, and passing through the head-block, the plate *i*, and metal shoes *m*, on the under side of the head-block, are thumb-screws, *n*, which are stepped in metal blocks, *o*, that are placed at the lower ends of the slots *k*.

On turning the screws *n* in the proper direction the wires *d* are either tightened or loosened.

In ordinary screens the main wires are stiffened by cross-wires, forming lattice work. Cross-wires retain part of the material that is thrown upon the screen, and the workmen are compelled to thump the latter with their shovels in order to dislodge the material thus retained. This not only wastes time, but injures the screen. In my invention there are no cross-wires, and consequently no obstruction to the free passage of the dirt.

I claim as my invention—

1. The frame *a b c*, in combination with the wires *d*, sliding head-block *h*, and screws *n*, substantially as specified.

2. The combination of the wires *d*, head-block *h*, notched plate *i*, and back-plate *f*, constructed as described.

GEORGE W. FAIR.

Witnesses:

DENIS REGAN,  
H. B. CHANDLER.