

E. H. POOL.  
 GRAIN WEIGHING MACHINE.  
 APPLICATION FILED AUG. 25, 1910.

999,863.

Patented Aug. 8, 1911.

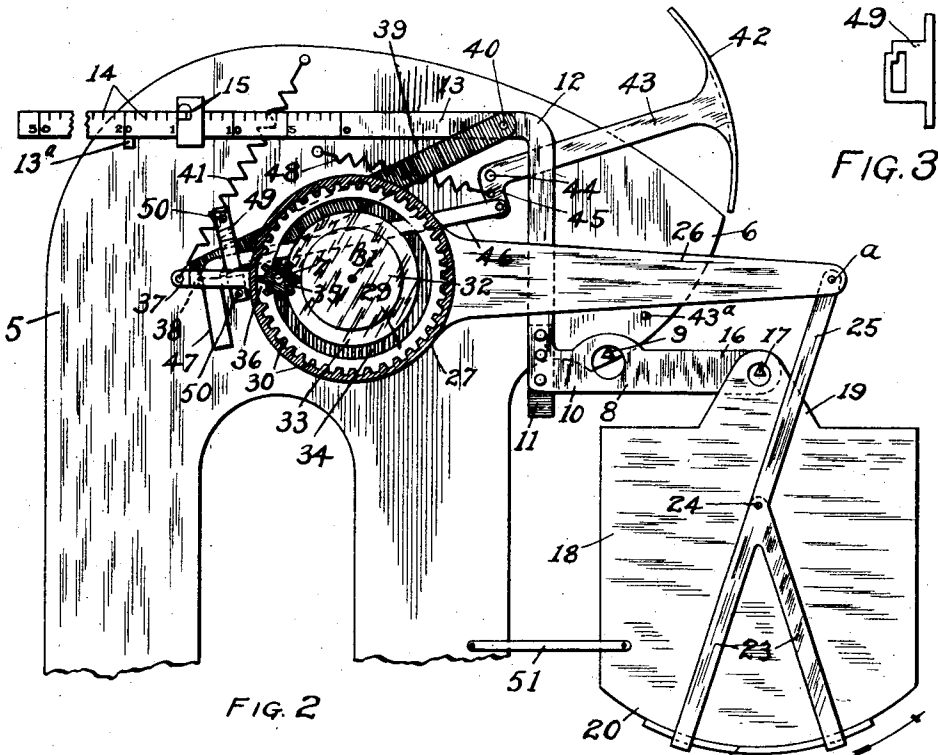
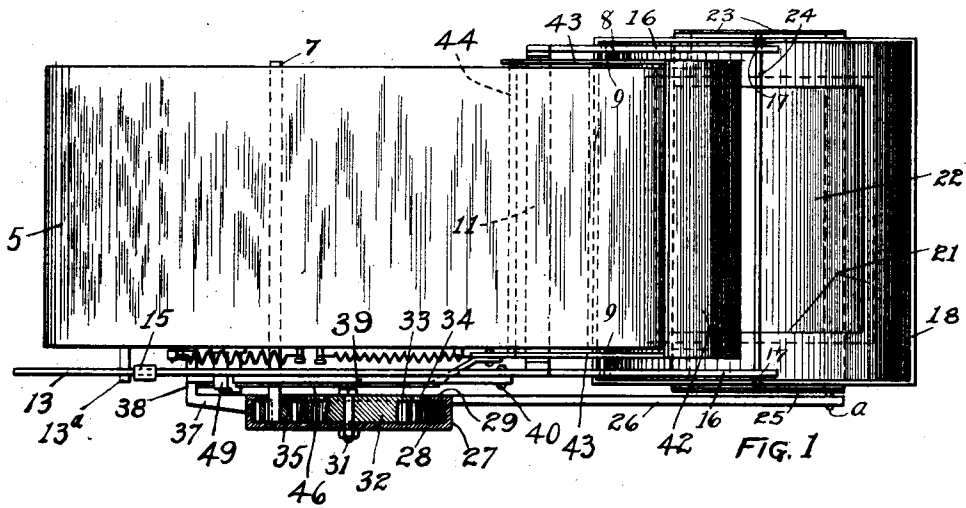

WITNESSES:  
*Amos Blomstrom*  
*M. A. Milob*

INVENTOR  
*Edgar H. Pool*  
 BY *Fredrick Bergman*  
 ATT'Y

# UNITED STATES PATENT OFFICE.

EDGAR H. POOL, OF YORKVILLE, ILLINOIS.

GRAIN-WEIGHING MACHINE.

999,863.

Specification of Letters Patent.

Patented Aug. 8, 1911.

Application filed August 25, 1910. Serial No. 578,869.

To all whom it may concern:

Be it known that I, EDGAR H. POOL, citizen of the United States, residing at Yorkville, in the county of Kendall and State of Illinois, have invented certain new and useful Improvements in Grain-Weighing Machines of which the following is a specification.

My invention relates to grain weighing machines, and has especial reference to apparatus adapted to be used on threshing machines and in connection with grain elevators in warehouses, or with any similar appliance for handling grain.

The chief objects of the improvements which constitute the subject matter of this application for patent are: to provide efficient means for the purpose stated, that may be readily connected to any of the grain elevating and conveying mechanisms in common use; to furnish a grain weighing apparatus that will automatically weigh, and discharge a predetermined quantity of grain while the latter is being conveyed from one place to another, and to so design and construct the machine that the quantity to be weighed may be readily and conveniently changed at any time, so that the amounts deposited may be varied at will, being limited only by the capacity of the particular apparatus in use.

Further objects of this invention, referred to in detail are: to furnish a grain weighing apparatus that may be attached directly to an elevator of the type in common use upon threshers; to provide a receptacle for receiving the grain to be weighed having connected therewith means for automatically dumping its contents; and to arrange a trip operated valve for controlling the grain supply, whereby the latter is cut off during the dumping process.

I accomplish the desired results above set forth and others of importance by the employment of the apparatus illustrated in the accompanying drawing, forming a part of this application and in which the details of construction are disclosed in the following views:—

Figure 1 is a top plan view showing my improved automatic grain weighing device attached to a grain elevator, the dump operating gears being shown in section. Fig. 2 is a side elevation of the apparatus shown in Fig. 1, with the gear housing and gear in section, only a portion of the elevator casing

being shown. Fig. 3 is a detail showing the guide block.

Referring to the details of the drawing, the numeral 5 indicates the casing of an ordinary grain elevator as used in connection with a threshing machine, 6 the supply chute through which the grain flows, and 7 the main driving shaft for the elevator mechanism (not shown). Arranged upon opposite sides of the chute 6 are horizontal scale levers 8, fulcrumed upon knife edges 9, conveniently supported upon the said chute. The rear ends or arms 10 of the said levers are rigidly connected together by a flat bar 11 bent into the form of a bail, which passes across underneath the chute. One of the arms 10 is continued upward a suitable distance and then bent backward at the point 12 and extended horizontally to form a scale beam 13, its movement being limited by a stop 13<sup>a</sup>. The scale beam 13 is marked with the usual graduations 14 indicating pounds and fractions, a balancing weight 15 being slidably mounted upon the beam as in ordinary scales. The front arms 16 of the levers 8 are somewhat longer than the rear arms and are furnished at their extremities with knife edges 17, upon which is suspended a weighing receptacle or hopper 18, having its ends extended upward in the form of ears 19 adapted to engage the said knife edges 17. The bottom of the receptacle 18 is made curved or rounded, as shown at 20, and has an opening 21, normally closed by a valve 22, extending longitudinally underneath the receptacle bottom, and supported at the ends by hanger 23, arranged to swing on a rod 24, extending through the hopper. One of the said hangers has an integral arm 25, extending upward to a suitable distance, and having its extremity pivotally connected to the forward end of a horizontal valve-operating lever 26, the rear end of the said lever being made in the form of a circular gear box or housing 27. The outer side 28 of this housing is entirely closed while the inner side is open with the exception of an annular peripheral inner flange 29, which lies parallel with the outer wall 28. The inner peripheral surface of the said box or housing is furnished with teeth 30, forming an internal gear. Attached to the center of the inner face of the wall 28 by a bolt 31, is a circular disk 32 having an annular flange 33, which lies in the same plane as the

flange 29. The said flange 33 is of less diameter than the opening of the peripheral flange 29, and consequently there is left an annular slot 34, between the inner and outer margins, respectively, of the said flanges 29 and 33. A spur gear or pinion 35, adapted to mesh with the internal gear 30, is mounted upon the outer end of the elevator shaft 7. This pinion is arranged within the housing 27 in the relation shown in the drawing, which illustrates the normal or position of rest of the lever 26. It will be seen that the shaft 7 passes through the annular slot 34, and several of the teeth 30 are omitted at the point 36 so that the pinion 35 is out of gear when in its normal position relatively to the gear box. Extending from the gear housing diametrically opposite the lever 26 is a finger 37, having a lug 38, projecting inwardly toward the casing 5. This lug is normally engaged by the lower end of an inclined trip bar or lever 39, pivoted at 40 to the scale beam 13. The lower end of the trip bar 39 extends above the lug 38, while a spring 41, attached to the end of the finger 37, tends to elevate the latter, but is prevented from doing so by the contact of the said trip bar, until the latter is moved out of the path of the lug 38 in a manner hereinafter explained.

The grain supply opening in the chute 6 is controlled by a supply valve 42, which extends entirely across the front of the chute and is attached to arms 43, pivoted to the sides of the elevator casing at 44, and limited in its downward movement by a stop 43<sup>a</sup>.

The arm 43 on the front side of the elevator casing is bent at an angle at the pivotal point so that it has a short downwardly projecting portion 45, to which is pivotally attached a valve operating member 46, inclined downwardly and rearwardly until it reaches the vicinity of the lug 38, where it is bent at a right angle to form a downwardly projecting arm 47. This arm, near its bend, rests against the front side of the said lug 38, so that the valve 42 is thus normally held in its open position. A spring 48 assists the action of gravity to close the said valve when the trip or operating member 46 is released. The members 39 and 46 are held in proper relation to the coacting parts by a guide block 49, provided with a suitable slot through which said members pass, and secured to the side of the elevator 5 by bolts 50. A link 51, pivotally connecting the hopper 18 to the elevator casing, steadies the former, preventing it from swinging forward when the valve 22 is opened.

Then general operation of the apparatus is as follows:—The various movable members being in their initial positions, as shown in the drawing, the balancing weight 15 is shifted to the position on the scale beam cor-

responding with the quantity of grain which it is desired to weigh in the hopper 18, and the shaft 7 set in motion by the usual connection (not shown) with any suitable source of power. All parts of the apparatus will remain at rest while the grain is passing through the chute 6 into the receptacle. As soon as the predetermined quantity has accumulated in the hopper 18 the scale beam 13 will rock on its fulcrum, carry the center 40 of the trip bar 39 forward until the lower end of the said bar is drawn entirely clear of the lug 38. The finger 37 being thus released the spring 41 will now move the rear end of the lever 26 upward, carrying the internal gear into mesh with the pinion 35 on the elevator shaft 7, and as the latter is continually in motion, the said pinion 35 will successively engage all the teeth of the gear 30. The effect of this gear action will be to carry the lug 38 in an approximately elliptical path at the end of which it will be returned to its initial position. The connection of the lever 26 to the arm 25, will reciprocate in an arc having its center at 24, moving the valve 22 in the direction of the arrow to its open position during the first half of the reciprocating movement, and carrying said valve back to its initial or closed position during the second half of the said movement. It will be readily seen that as the lug 38 is moved upward it will release the trip member 46, permitting the valve 42 to close and thus immediately shut off the flow of the grain from the chute. The resulting movement of the said trip member 46 will carry the pendant arm 47 into the path of the lug 38, and when the latter approaches its initial position it will engage the edge of said arm 47 and carry the valve 42 back to its open position. In the meantime the dumping of the grain from the hopper 18 will cause the scale beam to return to the initial position bringing the lower end of the trip bar 39 into the path of said lug 38, and preventing the latter from passing the initial point. The devices will now remain at rest, since the pinion 35 will be opposite the mutilated portion 36 of the internal gear, until the predetermined quantity of grain has been again discharged into the weighing hopper 18, when another cycle of movements will take place automatically.

Having thus described my invention, what I claim as new, is:—

1. In a grain weighing machine, the combination with a grain supply chute, a supply valve, a drive shaft, a pinion on said shaft, and a scale beam, of a grain hopper suspended on said scale beam and adapted to receive the grain from said chute, a discharge valve for said hopper, a lever connected with said discharge valve, a gear on said lever adapted to be engaged by said

pinion, a trip bar connected with said scale beam, an extension on said lever adapted to engage said bar and means adapted to be operated by said extension for opening said supply valve.

2. In a grain weighing machine, the combination with a supply chute, a supply valve, a drive shaft, a pinion on said shaft, and a scale beam, of a grain hopper, a discharge valve therefor, a lever connected with said discharge valve, an internal gear on said lever adapted to be engaged by said pinion, a trip bar pivoted on said scale beam and projecting into the path of said lever, and a trip member operatively connected with said supply valve and engaging said lever.

3. In a grain weighing apparatus, the combination with a grain supply chute, a grain supply valve therein, a drive shaft, a pinion on said shaft, a scale beam, a weighing hopper suspended on said scale beam and a discharge valve for the hopper, of a lever operatively connected at one end with said discharge valve, a spring suspending the other end of said lever, a gear on said lever adapted to be engaged by said pinion, a trip member connected to said scale beam and extending into the path of said lever, and means adapted to be engaged by said lever for automatically opening the said supply valve.

4. In a grain weighing apparatus, the combination with a grain supply chute, a grain supply valve, a drive shaft, a pinion on said shaft, a scale beam, a weighing hopper suspended on said scale beam, and a discharge valve for said hopper, of a lever operatively connected at one end with said discharge valve, and yieldingly suspended at the other end, an internal mutilated gear on said lever adapted to be engaged by said pinion, a trip bar attached to said scale beam and projecting into the path of said lever, means for automatically closing said supply valve and means for opening the supply valve by the action of said lever.

5. In a grain weighing apparatus, the combination with a drive shaft, a pinion therein, a grain supply chute, a valve therefor, a scale beam, a grain receptacle suspended on said scale beam, and a discharge valve for said receptacle, of means for automatically operating said valve, said operating means comprising a lever operatively connected with said discharge valve, a mutilated internal gear on said lever, a trip member connected to said scale beam and projecting into the path of said lever, and a supply valve opening member engaging said lever.

6. In a grain weighing apparatus, the combination with a drive shaft, a pinion thereon, a grain supply valve, a scale beam, a grain receptacle suspended on said beam, and a discharge valve for said receptacle, of a valve operating means comprising a lever yieldingly suspended at one end and operatively connected with one of said valves at the opposite end, a gear on said lever adapted to engage said pinion and means connected with said scale beam for controlling the operation of the lever.

7. In a grain weighing machine, the combination with a drive shaft, a pinion on said shaft, a supply valve, a grain weighing receptacle, and a discharge valve for said receptacle, of means for automatically operating said valves, said means comprising a lever yieldingly suspended at one end and connected with one of said valves at the other end, a mutilated gear on said lever and adapted to engage said pinion, and means controlled by said beam for engaging and disengaging said gear and pinion with each other.

In testimony whereof I affix my signature in the presence of two witnesses.

EDGAR H. POOL.

Witnesses:

GEO. N. RUBY,  
WILL OHSE.