

(No Model.)

4 Sheets—Sheet 1.

L. T. COOK.  
VARIABLE FEED FOR GANG STONE SAWS.

No. 559,441.

Patented May 5, 1896.

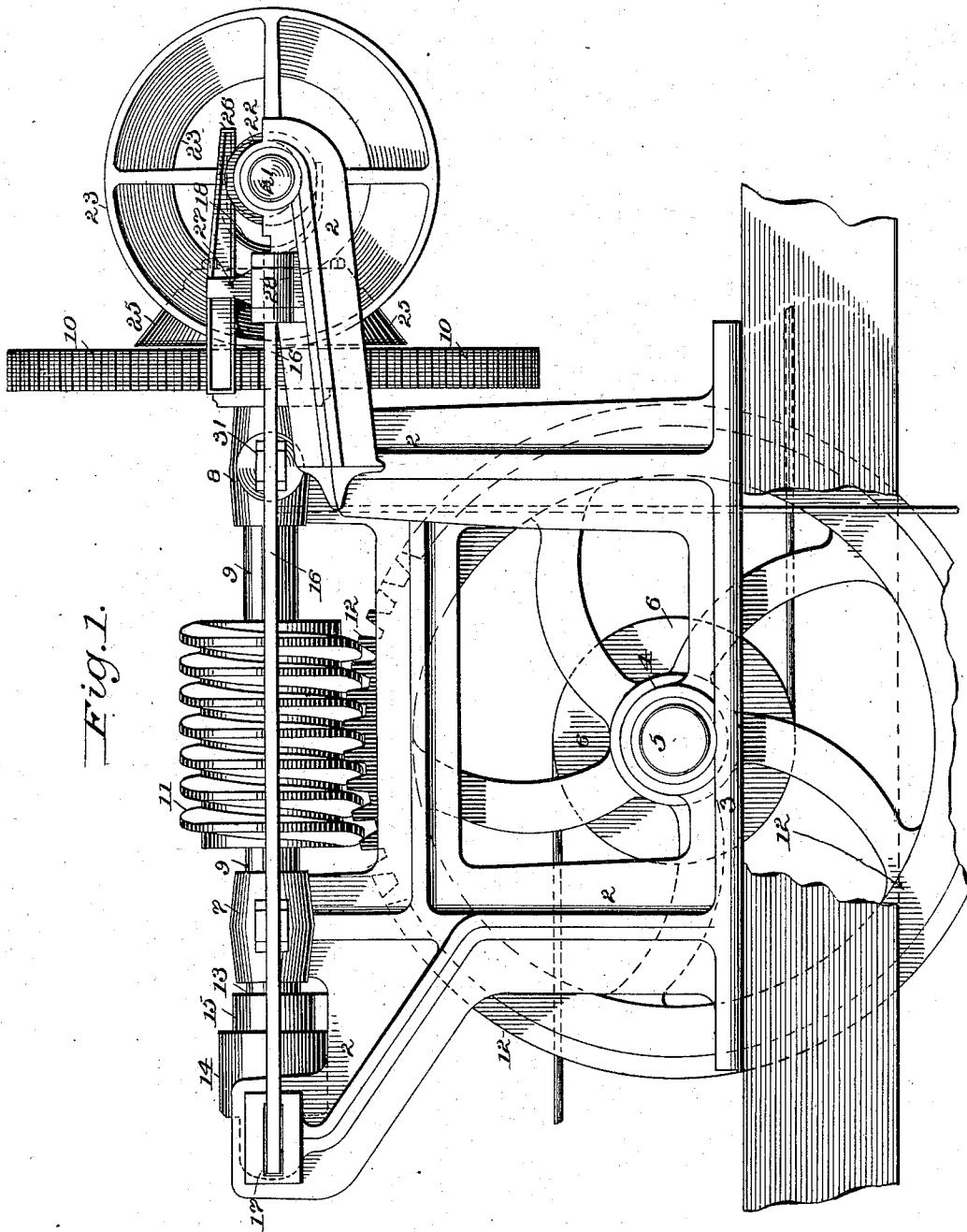

Fig. 1.

Witnesses  
*Arthur Bohley*  
*W. W. Deane*

Inventor  
*Louis T. Cook*  
by *Edward G. Weaver*  
his Attorney

(No Model.)

4 Sheets—Sheet 2.

L. T. COOK.  
VARIABLE FEED FOR GANG STONE SAWS.

No. 559,441.

Patented May 5, 1896.

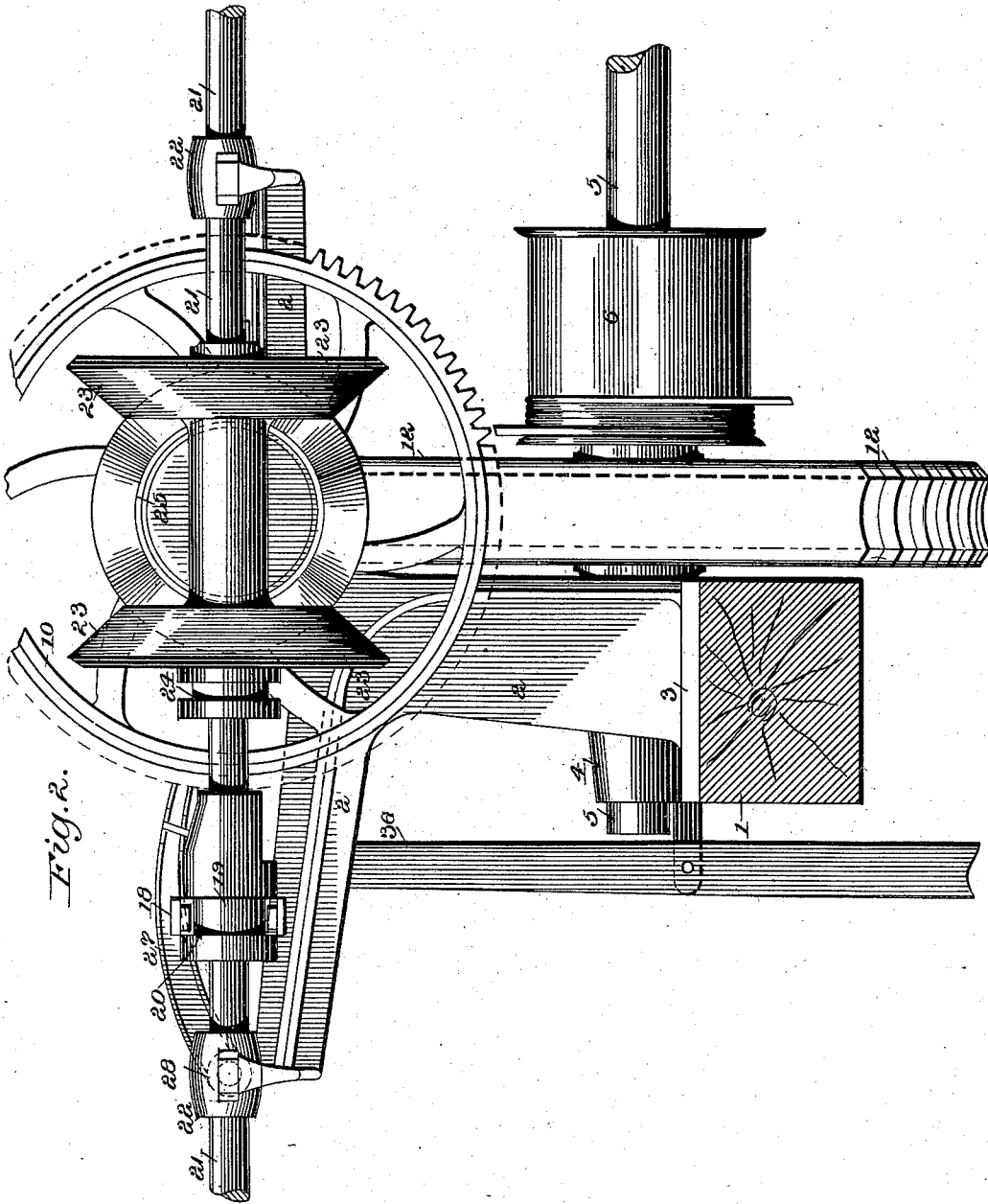

Witnesses  
William Ashley  
Wm W Deane

Inventor  
Louis T. Cook  
by Edward P. Weaver  
His Attorney

L. T. COOK.

VARIABLE FEED FOR GANG STONE SAWS.

No. 559,441.

Patented May 5, 1896.

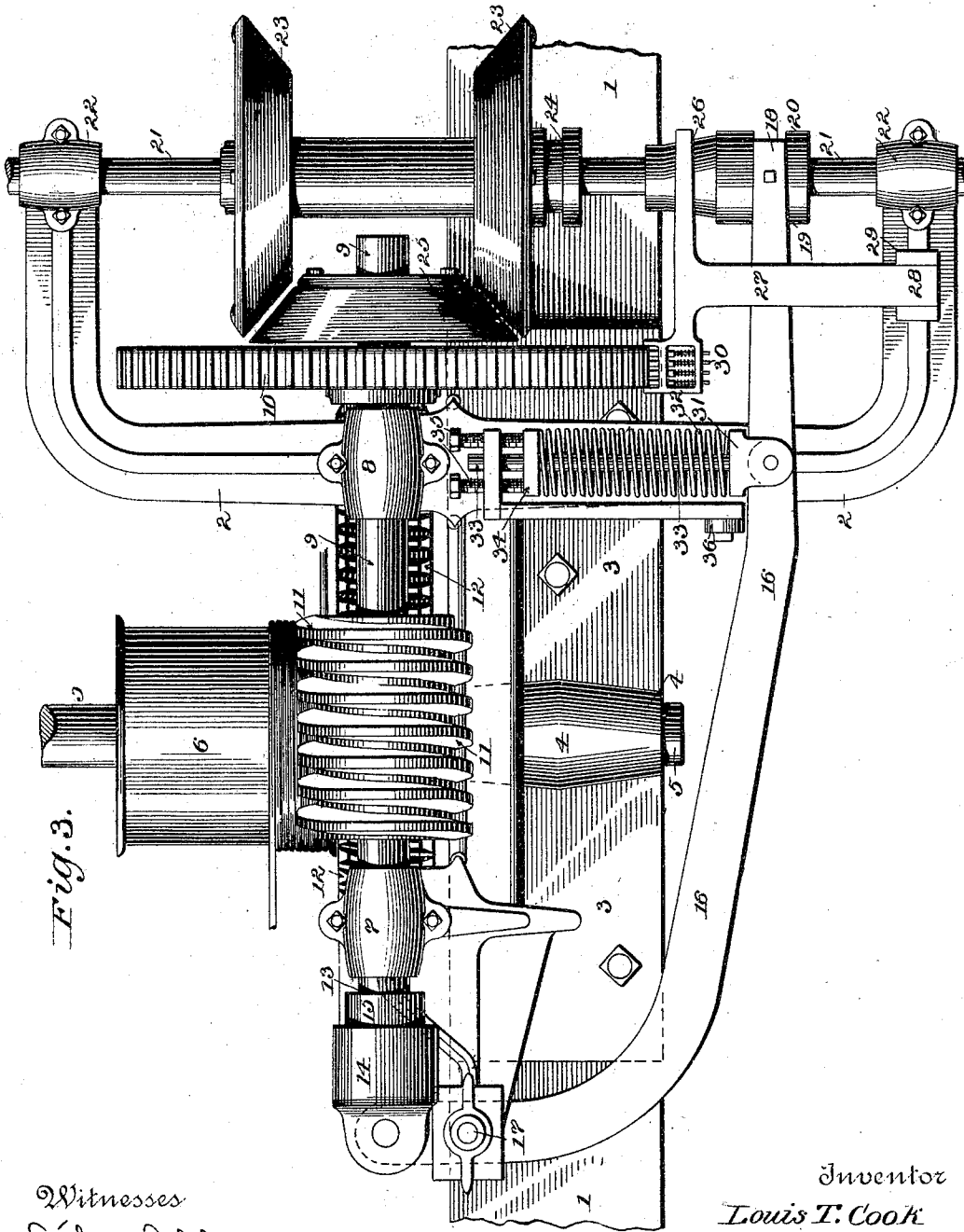

Fig. 3.

Witnesses  
*Arthur Ashley*  
*Wm W Deane*

Inventor  
*Louis T. Cook*  
 by *Edward P. Heaver*  
 his Attorney

L. T. COOK.

VARIABLE FEED FOR GANG STONE SAWS.

No. 559,441.

Patented May 5, 1896.

Fig. 4.

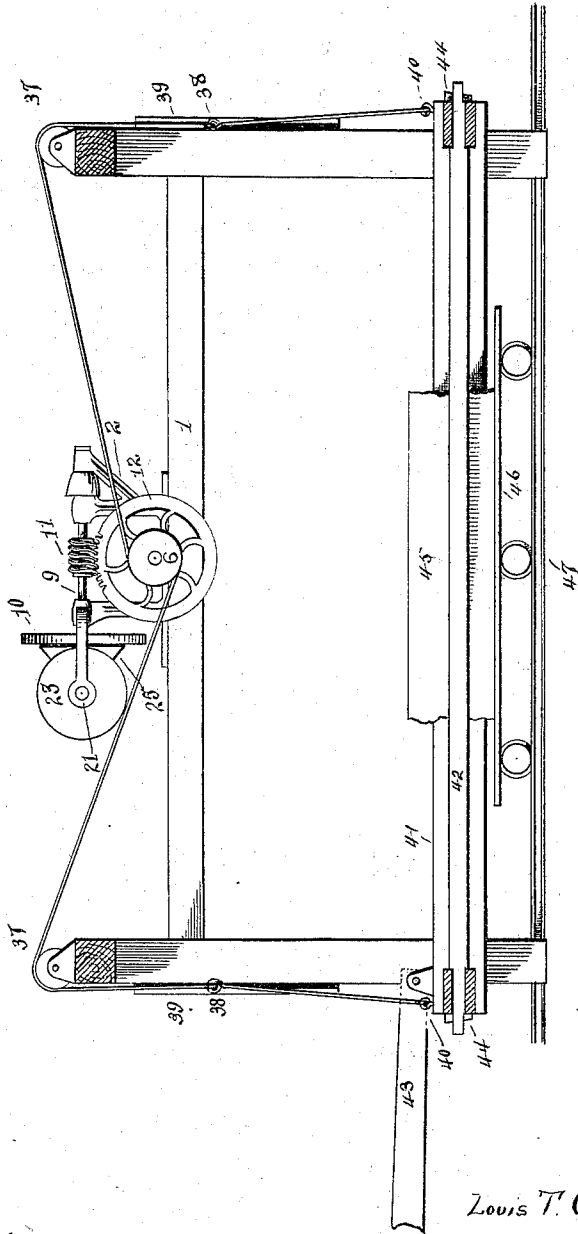

Witnesses

*J. M. Brown*  
*W. A. Huff*

Louis T. Cook, Inventor  
by

*Edward Weaver*

Attorney

# UNITED STATES PATENT OFFICE.

LOUIS THORP COOK, OF PORTSMOUTH, OHIO.

## VARIABLE FEED FOR GANG STONE-SAWS.

SPECIFICATION forming part of Letters Patent No. 559,441, dated May 5, 1896.

Application filed July 10, 1895. Serial No. 555,560. (No model.)

### *To all whom it may concern:*

Be it known that I, LOUIS THORP COOK, a citizen of the United States, residing at Portsmouth, in the county of Scioto and State of Ohio, have invented certain new and useful Improvements in Variable Feed for Gang Stone-Saws, of which the following is a specification, reference being had therein to the accompanying drawings.

My invention relates to feeding devices for stone gang-saws, more particularly for that class of gang-saws in which the gate or frame carrying the saw-blades proper is fed in and out of the work by means of a cable or rope, generally of wire.

It is often found in the cutting of blocks of stone of any size that there are portions much softer or harder than the remaining parts, and where this is the case positive feeding of the saw-blades results either in waste of time in the softer portions or the destruction of the saw in the harder portions.

It is the object of my invention to automatically vary the feed of the gate to conform to the hardness or density of the material being cut, and the mechanism by which I accomplish this result is hereinafter carefully described with the aid of the accompanying drawings. In them the same numeral always indicates the same part.

Figure 1 represents a side elevation of my invention; Fig. 2, an end elevation of the same, and Fig. 3 a plan view. Fig. 4 is a sectional view of the saw-frame with the gang and my feed device thereon.

1 represents the elevated beam usually found in the structure of a gang-saw such as has been designated. Upon this beam is placed a metallic framework 2, in the base-plate 3 of which is located a boxing 4, bearing shaft 5 of the drum 6, over which is rove the usual rope or cable supporting the saw-gate, and which operates to raise and lower the same.

Above the boxing 4 and in extremities of the framework or spider 2 are located two boxings 7 and 8, in which rotates shaft 9, which is slotted and carries the large keyed ratchet-wheel 10, the said ratchet-wheel while rotating with the said shaft having free longitudinal movement thereon. Between the boxings 7 and 8 there is firmly mounted upon

the shaft 9 a worm 11, engaging a worm gear-wheel 12, mounted upon the before-mentioned shaft 5 and actuating the same, as will be hereinafter described.

At the end 13 of the shaft 9 is a metallic thimble 14 with bushing 15, into which the extremity of the said shaft is inserted. This thimble 14 is pivoted to the end of lever 16, which is fulcrumed at 17 and is forked at its free end 18 to embrace an annular slot 19 in the body of a conical cam 20. This cam 20 is mounted upon the shaft 21, rotating in boxes or bearings 22 of the frame or spider 2. Also mounted upon this shaft 21 are the opposing bevel friction-gears 23, which, by means of sliding clutch 24, may be made to engage the bevel friction-gear 25, mounted upon the shaft 9 and firmly fastened to the ratchet-wheel 10 to give motion thereto.

Resting upon the face of the conical cam 20 is the free end 26 of a T-formed lever 27, the stem 28 of which is horizontally pivoted to the frame or spider 2 at 29. The other extremity of the lever 27 is provided with a plurality of pawl-points 30, which engage the ratchets of the ratchet-wheel and give rotation to the same.

Pivoted to the lever 16, between its fulcrum 17 and its fork 18, is a spring-head 31 of spring 32, mounted upon a keeper-rod 33 and provided with an end plate 34 with screw adjustment 35. This screw adjustment is governed in its position by the lever 36, the free end of which may be set to predetermined positions for purposes to be hereinafter mentioned.

Fig. 4 shows the operation of the before-mentioned ropes rove over the drum 6, the said ropes running over the fixed pulleys 37 to a guide 38, sliding in guideway 39 and fastened by eye 40 to gang-gate 41, carrying saw 42 and operated by pitman 43. The said saw is pinned into the gate by pins 44 and operates to cut stone 45 on car 46 running on trackway 47.

Having described my device I will now detail its operation.

We will presume that the gate or saw-frame is dragging upon its supporting-cable. This tends to rotate the worm-gear 12 and to thrust the worm 11 in the direction of the thimble 14 and carries its shaft 9 in the same direction. This pressure upon the thimble 14 ac-

tuates the lever 16 and moves the conical cam 20 upon its shaft 21 and thus places a larger portion of the said cam under the arm of the T-lever 27 and gives it an increased play, thus moving the ratchet-wheel 10 through a greater space. The increased rotation of the ratchet-wheel 10 gives increased rotation to the worm 11, the worm-gear 12, and to the drum 6, and thus feeding the cable out the more rapidly. Upon the other hand, we will presume that the saw-gate tends to ride upon the work, being fed too rapidly. The pressure at the thimble 14 will be removed and the spring 32 will press the said lever outward and slide the conical cam 20 in such direction that the lever 27 will rest upon a smaller portion of the said cam, and consequently reduce the space of travel of the pawl-points 30 and cause them to take up fewer teeth of the ratchet-wheel 10, and in the manner already described lessen the fall of the supporting-cables of the saw-gate.

By having the pawl-points 30 or a sectional pawl the effect of a greatly-increased number of ratchets upon the ratchet-wheel is obtained, increasing the sensitiveness of its action.

When it is desired to raise or lower the gate rapidly, the beveled wheels 23 are made to engage the bevel-wheel 25 and rapidly rotate the same in such direction as desired, according to which wheel 23 is so engaged. During this time the pawl 30 is raised from engagement with its ratchet. It is to be further noted that rotation is given to the shaft 21 from some convenient source of power not necessary to further describe.

The screw adjustment 35 operates to regulate the force of the spring 32, and thus determines the amount of weight necessary upon the gate-cable to actuate the variable mechanism and its conical cam 30 to the desired end.

What I desire to claim in my Letters Patent is—

1. A gang-saw feed, comprising a drum for the supporting-cable, worm-gearing rotating said drum, a ratchet-wheel operating said worm-gearing and a cam-actuated pawl having a variable sweep, controlled in its movements by the varying drag or weight of the saw-gate upon the cable-drum, substantially as described.

2. A gang-saw feed comprising a worm meshing the cable-drum gear, a ratchet-wheel

keyed to the worm, a pawl rotating the ratchet, a conical cam actuating the said pawl, combined with a mechanism for shifting the conical cam to vary the throw of the pawl, said mechanism comprising a shifting lever actuated by the longitudinal movement of the before-described worm caused by the pressure of the drum-gear upon the thread of the said worm, substantially as described.

3. A gang-saw feed, comprising a cable-drum with gear therefor, a revolubly-mounted shaft bearing at one end a bevel-wheel and a ratchet-wheel, and at its mid-portion a worm meshing the before-mentioned drum-gear, and impinging at its other end a lever 16, a line-shaft mounted at right angles to the said worm-shaft and bearing parallel bevel-wheels and a feathered conical cam, a pivoted pawl engaging the before mentioned ratchet-wheel and actuated by the said feathered conical cam, means for connecting the said cam with the lever 16, and an adjustable balance-spring for the said lever, substantially as described.

4. A gang-saw feed, comprising a cable-drum with gear therefor, a revolubly-mounted shaft bearing at one end a bevel-wheel and a ratchet-wheel, and at its mid-portion a worm meshing the before-mentioned drum-gear, and impinging at its other end a lever 16, a line-shaft mounted at right angles to the said worm-shaft and bearing parallel bevel-wheels and a feathered conical cam, a pivoted pawl engaging the before-mentioned ratchet-wheel and actuated by the said feathered conical cam, means for connecting the said cam with the lever 16, and an adjustable balance-spring for the said lever, combined with a mechanism for engaging the bevel-wheels for the purpose, and substantially as described.

5. In a gang-saw feed of the type described, a variable pawl movement comprising a truncated T-pawl, a conical cam actuating the said pawl, a pivoted lever, one end sliding the conical cam and the other end moved by the weight of the gate, combined with a regulating-spring for the said lever, substantially as described.

In testimony whereof I affix my signature in presence of two witnesses.

LOUIS THORP COOK.

Witnesses:

THOS. W. POWER,  
CHARLES E. RIORDAN.