

(19) World Intellectual Property Organization
International Bureau



(43) International Publication Date
12 January 2012 (12.01.2012)

(10) International Publication Number
WO 2012/005771 A2

- (51) **International Patent Classification:**
H01L 33/58 (2010.01)
- (21) **International Application Number:**
PCT/US20 11/001200
- (22) **International Filing Date:**
6 July 2011 (06.07.2011)
- (25) **Filing Language:** English
- (26) **Publication Language:** English
- (30) **Priority Data:**
61/399,084 6 July 2010 (06.07.2010) US
- (71) **Applicant (for all designated States except US):** CREE, INC. [US/US]; 4600 Silicon Drive, Durham, NC 27703 (US).
- (72) **Inventors; and**
- (75) **Inventors/Applicants (for US only):** BHAT, Chandan [IN/US]; 37 Dearborn Place #7, Goleta, CA 93117 (US). LOWES, Theodore, Douglas [CA/US]; 527 Cypress Ct., Lompoc, CA 93436 (US). GARCERAN, Julio [US/US]; 120 Morris Branch Court, Cary, NC 27519 (US). KELLER, Bernd [DE/US]; 1335 San Antonio Creek Road, Santa Barbara, CA 93111 (US).
- (74) **Agents:** HEYBL, Jaye, G. et al; Koppel, Patrick, Heybl & Philpott, 2815 Townsgate Road, Suite 215, Westlake Village, CA 91316 (US).
- (81) **Designated States (unless otherwise indicated, for every kind of national protection available):** AE, AG, AL, AM, AO, AT, AU, AZ, BA, BB, BG, BH, BR, BW, BY, BZ, CA, CH, CL, CN, CO, CR, CU, CZ, DE, DK, DM, DO, DZ, EC, EE, EG, ES, FI, GB, GD, GE, GH, GM, GT, HN, HR, HU, ID, IL, IN, IS, JP, KE, KG, KM, KN, KP, KR, KZ, LA, LC, LK, LR, LS, LT, LU, LY, MA, MD, ME, MG, MK, MN, MW, MX, MY, MZ, NA, NG, NI, NO, NZ, OM, PE, PG, PH, PL, PT, RO, RS, RU, SC, SD, SE, SG, SK, SL, SM, ST, SV, SY, TH, TJ, TM, TN, TR, TT, TZ, UA, UG, US, UZ, VC, VN, ZA, ZM, ZW.
- (84) **Designated States (unless otherwise indicated, for every kind of regional protection available):** ARIPO (BW, GH, GM, KE, LR, LS, MW, MZ, NA, SD, SL, SZ, TZ, UG, ZM, ZW), Eurasian (AM, AZ, BY, KG, KZ, MD, RU, TJ, TM), European (AL, AT, BE, BG, CH, CY, CZ, DE, DK, EE, ES, FI, FR, GB, GR, HR, HU, IE, IS, IT, LT, LU, LV, MC, MK, MT, NL, NO, PL, PT, RO, RS, SE, SI, SK, SM, TR), OAPI (BF, BJ, CF, CG, CI, CM, GA, GN, GQ, GW, ML, MR, NE, SN, TD, TG).

[Continued on next page]

(54) **Title:** COMPACT OPTICALLY EFFICIENT SOLID STATE LIGHT SOURCE WITH INTEGRATED THERMAL MANAGEMENT

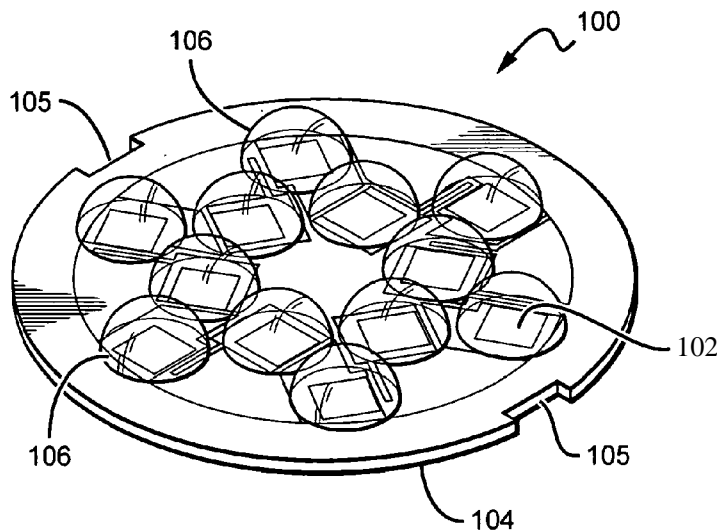
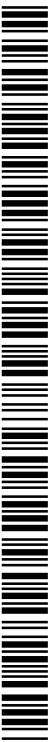

FIG. 10

(57) **Abstract:** A compact and efficient LED array lighting component comprising a circuit board with an array of LED chips mounted on it and electrically interconnected. A plurality of primary lenses is included, each of which is formed directly over each LED chip and/or a sub-group of the LED chips. A heat sink is included with the circuit board mounted to the heat sink so that heat from the LED chips spreads into the heat sink. In some embodiments the circuit board can be thermally conductive and electrically insulating. Method of forming an LED component are also disclosed utilizing chip-on-board mounting techniques for mounting the LED chips on the circuit board, and molding of the primary lenses directly over the LED chips individually or in sub-groups of LED chips.



WO 2012/005771 A2

P1295US1-7

PATENT

**COMPACT OPTICALLY EFFICIENT SOLID STATE LIGHT SOURCE WITH
INTEGRATED THERMAL MANAGEMENT**

This application claims the benefit of U.S. Provisional Patent Application serial number 61/339,084, filed on July 6, 2010.

BACKGROUND OF THE INVENTION

Field of the Invention

[0001] This invention relates to solid state lighting and in particular to solid state light sources or lamps that comprise a compact array of light emitting diodes (LEDs).

Description of the Related Art

[0002] Light emitting diodes (LED or LEDs) are solid state devices that convert electric energy to light, and generally comprise one or more active layers of semiconductor material sandwiched between oppositely doped layers. When a bias is applied across the doped layers, holes and electrons are injected into the active layer where they recombine to generate light. Light is emitted from the active layer and from all surfaces of the LED.

[0003] LEDs have certain characteristics that make them desirable for many lighting applications that were previously the realm of incandescent or fluorescent lights. Incandescent lights are very energy-inefficient light

sources with approximately ninety percent of the electricity they consume being released as heat rather than light. Fluorescent light bulbs are more energy efficient than incandescent light bulbs by a factor of about 10, but are still relatively inefficient. LEDs by contrast, can emit the same luminous flux as incandescent and fluorescent lights using a fraction of the energy.

[0004] In addition, LEDs can have a significantly longer operational lifetime. Incandescent light bulbs have relatively short lifetimes, with some having a lifetime in the range of about 750-1000 hours. Fluorescent bulbs can also have lifetimes longer than incandescent bulbs such as in the range of approximately 10,000-20,000 hours, but provide less desirable color reproduction. In comparison, LEDs can have lifetimes between 50,000 and 70,000 hours. The increased efficiency and extended lifetime of LEDs is attractive to many lighting suppliers and has resulted in their LED lights being used in place of conventional lighting in many different applications. It is predicted that further improvements will result in their general acceptance in more and more lighting applications. An increase in the adoption of LEDs in place of incandescent or fluorescent lighting would result in increased lighting efficiency and significant energy saving.

[0005] In order to use an LED chip in a circuit or other like arrangement, it is known to enclose an LED chip in a package to provide environmental and/or mechanical protection, color selection, light focusing and the like. An LED package also includes electrical leads, contacts or traces for electrically connecting the LED package to an

external circuit. In a typical LED package/component 10 illustrated in FIG. 1, a single LED chip 12 is mounted on a reflective cup 13 by means of a solder bond or conductive epoxy. One or more wire bonds 11 connect the ohmic contacts of the LED chip 12 to leads 15A and/or 15B, which may be attached to or integral with the reflective cup 13. The reflective cup 13 may be filled with an encapsulant material 16 which may contain a wavelength conversion material such as a phosphor. Light emitted by the LED at a first wavelength may be absorbed by the phosphor, which may responsively emit light at a second wavelength. The entire assembly is then encapsulated in a clear protective resin 14, which may be molded in the shape of a lens to collimate the light emitted from the LED chip 12. While the reflective cup 13 may direct light in an upward direction, optical losses may occur when the light is reflected (i.e. some light may be absorbed by the reflector cup due to the less than 100% reflectivity of practical reflector surfaces). In addition, heat retention may be an issue for a package such as the package 10 shown in FIG. 1, since it may be difficult to extract heat through the leads 15A, 15B.

[0006] LED component 20 illustrated in FIG. 2 may be more suited for high power operations which may generate more heat. In LED component 20, one or more LED chips 22 are mounted onto a carrier such as a printed circuit board (PCB) carrier, substrate or submount 23. A metal reflector 24 is mounted on the submount 23, surrounds the LED chip(s) 22, and reflects light emitted by the LED chips 22 away from the package 20. The reflector 24 also provides mechanical protection to the LED chips 22. One or more wire

bond connections 11 are made between ohmic contacts on the LED chips 22 and electrical traces 25A, 25B on the submount 23. The mounted LED chips 22 are then covered with an encapsulant 26, which may provide environmental and mechanical protection to the chips while also acting as a lens. The metal reflector 24 is typically attached to the carrier by means of a solder or epoxy bond.

[0007] Other LED components or lamps have been developed that comprise an array of multiple LED packages mounted to a (PCB), substrate or submount. The array of LED packages can comprise groups of LED packages emitting different colors, and specular reflector systems to reflect light emitted by the LED chips. Some of these LED components are arranged to produce a white light combination of the light emitted by the different LED chips.

[0008] Techniques for generating white light from a plurality of discrete light sources have been developed that utilize different hues from different discrete light sources, such as those described in U.S. Patent No. 7,213,940, entitled "Lighting Device and Lighting Method". These techniques mix the light from the discrete sources to provide white light. In some applications, mixing of light occurs in the far field such that when viewed directly the different hued sources of light can be separately identified, but in the far field the light combines to produce light which is perceived as white. One difficulty with mixing in the far field is that the individual discrete sources can be perceived when the lamp or luminaire is viewed directly. Accordingly, the use of only far field mixing may be most appropriate for these lighting

applications where the light sources are mechanically obscured from a user's view. However, mechanically obscuring the light sources may result in lower efficiency as light is typically lost by the mechanical shielding.

[0009] Current LED packages (e.g. XLamp® LEDs provided by Cree, Inc.) can be limited in the level of input power and for some the range is 0.5 to 4 Watts. Many of these conventional LED packages incorporate one LED chip and higher light output is achieved at the assembly level by mounting several of these LED packages onto a single circuit board. FIG. 3 shows a sectional view of one such distributed integrated LED array 30 comprising a plurality of LED packages 32 mounted to a substrate or submount 34 to achieve higher luminous flux. Typical arrays include many LED packages, with FIG. 3 only showing two for ease of understanding. Alternatively, higher flux components have been provided by utilizing arrays of cavities, with a single LED chip mounted in each of the cavities. (e.g. TitanTurbo™ LED Light Engines provided by Lamina, Inc.).

[0010] These LED array solutions are less compact than desired as they provide for extended non-light emitting "dead space" between adjacent LED packages and cavities. This dead space provides for larger devices, and can limit the ability to diffuse light from the LED packages and can limit the ability to shape the output beam by a single compact optical element like a collimating lens or reflector into a particular angular distribution. This makes the construction of solid state lighting luminaires that provide for directed or collimated light output within the form factor of existing lamps difficult to provide.

These present challenges in providing a compact LED lamp structure incorporating an LED component that delivers light flux levels in the 1000 lumen and higher range from a small optical source.

[0011] In other array technologies, individual blue LEDs can be assembled on a circuitized substrate (i.e. chip-on-board). The LEDs are then encapsulated together utilizing a flat profile where the encapsulant contains a phosphor to enable down conversion. This approach, however, is not efficient from a light extraction perspective because of the difference in the refractive index of the flat encapsulant and the surrounding material. A portion of the light can be reflected back at the surface of the encapsulant where a portion of it can be absorbed by components that are less than ideal reflectors. Additional light can be lost to total internal reflection (TIR). To be more efficient, these technologies can require optimal reflectivity within the regions where light is generated.

SUMMARY OF THE INVENTION

[0012] The present invention is directed to solid state light sources that are compact, efficient and compatible with high volume manufacturing processes. The present invention relates to improved arrangements of LED chips and lenses/optics on a substrate that provide efficiency improvements, such as first pass light extraction from the lenses/optics LED while maintaining efficient component thermal management.

[0013] One embodiment of LED component according to the present invention comprises a circuit board having a

plurality of die attach pads. A plurality of LED chips is included each of which is mounted on a respective one of the die attach pads. Primary lenses are included each of which is formed directly over a single one or a subgroup of the LED chips.

[0014] Another embodiment of an LED component according to the present invention comprises a circuit board with an array of LED chips mounted on it and electrically interconnected. A plurality of primary lenses is included, each of which is formed directly over a single one or a subgroup of the LED chips. A heat sink is included with the circuit board mounted to the heat sink so that heat from the LED chips spreads into the heat sink.

[0015] .One embodiment of a solid state lighting component according to the present invention comprises a circuit board that is thermally conductive and electrically insulating. A plurality of LED chips is included, each of which is chip-on-board mounted on a respective one of the die attach pads. A plurality of primary lenses is included each of which is formed directly over a single one or a subgroup of the LED chips.

[0016] A method of forming an LED component comprises providing a circuit board and chip-on-board mounting LED chips on the circuit board with the LED chips electrically interconnected. Primary lenses are molded directly over each of the LED chips individually or in sub-groups of the LED chips.

[0017] These and other aspects and advantages of the invention will become apparent from the following detailed

description and the accompanying drawings which illustrate by way of example the features of the invention.

BRIEF DESCRIPTION OF THE DRAWINGS

[0018] FIG. 1 shows a prior art LED package;

[0019] FIG. 2 shows another prior art LED package;

[0020] FIG. 3 shows a prior art LED component with an array of LED packages;

[0021] FIG. 4 is a perspective view of one embodiment of an LED component according to the present invention having an array of LED chips in sub-groups;

[0022] FIG. 5 is a perspective view of the LED component of FIG. 4 mounted to a heat sink;

[0023] FIG. 6 is a perspective view of the LED component of FIG. 4 mounted to a heat sink;

[0024] FIG. 7 is a perspective view of another embodiment of an LED component according to the present invention having an array of LED chips in sub-groups;

[0025] FIG. 8 is a perspective view of another embodiment of an LED component according to the present invention;

[0026] FIG. 9 is top view of the LED component shown in FIG. 8;

[0027] FIG. 10 is a perspective view of the LED component shown in FIG. 8 with primary lenses over the LED chips;

[0028] FIG. 11 is a side view of one embodiment of an LED component according to the present invention without the LED chips visible through the primary lenses;

[0029] FIG. 12 is a top view of the LED component shown in FIG. 11;

[0030] FIG. 13 is perspective view of the LED component shown in FIG. 11;

[0031] FIG. 14 is a perspective view of another embodiment of an LED component according to the present invention mounted to a heat sink;

[0032] FIG. 15 is a perspective view of another embodiment of an LED component according to the present invention mounted to a heat sink;

[0033] FIG. 16 is a perspective view of another embodiment of an LED component according to the present invention;

[0034] FIG. 17 is a perspective view of the LED component shown in FIG. 16;

[0035] FIG. 18 is a graph showing the operating characteristics of some embodiments of an LED component according to the present invention;

[0036] FIG. 19 is a top view of another embodiment of an LED component according to the present invention;

[0037] FIG. 20 is a top view of the LED component in FIG. 19 with primary optics over some of the LED chips;

[0038] FIG. 21 is a perspective view of the LED component in FIG. 19 with primary optics over all of the LED chips;

[0039] FIG. 22 is a top view of another embodiment of an LED component according to the present invention;

[0040] FIG. 23 is a top view of another embodiment of an LED component according to the present invention;

[0041] FIG. 24 is a top view of a reflective layer that can be used on LED components according to the present invention;

[0042] FIG. 25 is a perspective view of another embodiment of an LED component according to the present invention;

[0043] FIG. 26 is a top view of the LED component shown in FIG. 25;

[0044] FIG. 27 is a side view of the LED component shown in FIG. 25;

[0045] FIG. 28 is a top view of another embodiment of an LED component according to the present invention;

[0046] FIG. 29 is a side view of another embodiment of an LED component according to the present invention comprising secondary lens/optic;

[0047] FIG. 30 is a side view of another embodiment of an LED component according to the present invention comprising secondary lens/optic; and

[0048] FIG. 31 is a side view of still another embodiment of an LED component according to the present invention comprising secondary lens/optics.

DETAILED DESCRIPTION OF THE INVENTION

[0049] The present invention provides compact and efficient lighting components that utilize solid state devices as their light source. The different lighting components are sized such that they are capable of being used in many different lighting applications. In some embodiments the solid state light source can comprise an array of LEDs arranged to emit light in response to an electrical signal applied to the lighting component. Some embodiments of the present invention also provide LED array lighting components with improved light extraction efficiency enabled by improved optical and thermal properties. The present invention also incorporates optical designs that maximize first pass light extraction, and features that manage thermal loads to minimize thermal cross-talk between individual LED emitters.

[0050] Some embodiments of lighting components according to the present invention can comprise an LED chip array mounted on a thermally conductive substrate, with optics that minimizes emission crosstalk. Different embodiments can utilize chip-on-board (COB) technology to integrate multiple LEDs onto a single circuitized substrate with the "dead-space" between LEDs minimized and thereby minimizing the space required for the light source. COB refers to the semiconductor assembly techniques wherein a microchip or die, such as an LED, is directly mounted on and electrically interconnected to its final circuit board, instead of undergoing traditional assembly or packaging as an individual LED package or integrated circuit. The elimination of conventional device packaging when using COB

assemblies can simplify the over-all process of designing and manufacturing, can reduce space requirements, can reduce cost, and can improve performance as a result of the shorter interconnection paths. The COB process can consist of three primary steps: 1) LED die attach or die mount; 2) wire bonding; and 3) encapsulation of the die and wires. These COB arrangements can also provide the added advantage of allowing for direct mounting and interface with the main system heat sink.

[0051] In some embodiments LED array embodiments, each chip in the array can have its own primary lens formed onto it to facilitate light extraction and emission with the first pass. First pass light extraction/emission refers to light emitted from a particular LED chip passing out of its primary lens and the light's first pass from the LED chip to the surface of the primary lens. That is, the light is not reflected back, such as by total internal reflection (TIR), where some of the light can be absorbed. This first pass emission enhances the emission efficiency of the LED components by minimizing LED light that can be absorbed. The different embodiments can comprise a high density of light emitting components while maximizing the light extraction, which maximizes the efficiency of the overall component. Some embodiments of the present invention can be arranged in sub-groups of LED chips within the array, with each sub-group having its own primary lens for improved light extraction. In some embodiments, the lens can be hemispheric, which can further increase light extraction by providing a lens surface that promotes first pass light emission .

[0052] Different embodiments of the present invention can include LED arrays with LED chips emitting the same color or different color (e.g. red, green and blue LED chips or subgroups, white LED and red LED chips or subgroups, etc.) Techniques for generating white light from a plurality of discrete light sources to provide desired CRI at the desired color temperature have been developed that utilize different hues from different discrete light sources. Such techniques are described in U.S. Patent No. 7,213,940, entitled "Lighting Device and Lighting Method" mentioned above .

[0053] In other embodiments a secondary lens or optic may be used in addition to the primary lens or optics, e.g. a larger secondary optic over multiple groups of emitters with primary optics. With each emitter or groups of emitters having their own primary lens or optic, the invention may be scalable for larger arrays. Different arrays according to the present invention can have as little as three chips to 10s and 100s.

[0054] In some embodiments the LED array can be COB mounted to a board having characteristics that provide for improved operation. The board can provide electrical isolation characteristics, which allows for board level electrical isolation of the LED chips. At the same time the board can have properties that provide an efficient thermal path to spread heat from the LED chips. Efficient thermal spreading of heat from the LED chips can result in improved LED chip reliability and color consistency. The board can also be arranged to allow for easy and efficient mounting of the array to a primary heat sink. Some embodiments can comprise

a circuit board having features that allow it to be easily and efficiently mounted to the heat sink using mechanical means. In other embodiments, the circuit board can comprise a material that allows it to be efficiently and reliably soldered to a heat sink, such as through reflow processes.

[0055] The present invention comprises LED array arrangements that are scalable, such that some embodiments can have as few as three emitters and others can have as many as 10s or 100s of emitters. Different embodiments of LED arrays can be scalable.

[0056] The present invention is described herein with reference to certain embodiments, but it is understood that the invention can be embodied in many different forms and should not be construed as limited to the embodiments set forth herein. In particular, the present invention is described below in regards to certain lighting or LED components having arrays of LEDs or LED chips in different configurations, but it is understood that the present invention can be used for many other lamps having many different array configurations. The components can have different shapes and sizes beyond those shown and different numbers of LEDs can be included in the arrays. Some or all of the LEDs in the arrays can be coated with a down-converter coating that can comprise a phosphor loaded binder ("phosphor/binder coating"), but it is understood that LEDs without a conversion material can also be used.

[0057] It is also understood that when an element such as a layer, region or substrate is referred to as being "on", "over" or "coating" another element, it can be directly on, over or coating the other element or intervening elements

may also be present. Furthermore, relative terms such as "inner", "outer", "upper", "above", "lower", "beneath", and "below", and similar terms, may be used herein to describe a relationship of one layer or another region. It is understood that these terms are intended to encompass different orientations of the device in addition to the orientation depicted in the figures.

[0058] Although the terms first, second, etc. may be used herein to describe various elements, components, regions, layers and/or sections, these elements, components, regions, layers and/or sections should not be limited by these terms. These terms are only used to distinguish one element, component, region, layer or section from another region, layer or section. Thus, a first element, component, region, layer or section discussed below could be termed a second element, component, region, layer or section without departing from the teachings of the present invention.

[0059] Embodiments of the invention are described herein with reference to certain view illustrations that may be schematic illustrations of embodiments of the invention. As such, the actual size and thickness of elements can be different, and variations from the shapes of the illustrations as a result, for example, of manufacturing techniques and/or tolerances are expected. Embodiments of the invention should not be construed as limited to the particular shapes and sizes of the regions illustrated herein but are to include deviations in shapes that result, for example, from manufacturing. A region illustrated or described as square or rectangular can have rounded or curved features due to normal manufacturing tolerances.

Thus, the regions illustrated in the figures are schematic in nature and their shapes are not intended to illustrate the precise shape of a region of a device and are not intended to limit the scope of the invention.

[0060] FIG. 4 shows one embodiment of an LED component 40 according to the present invention comprising a circuit board or submount ("board") 42 for holding an array of LED chips 41, with the board 42 having die attach pads 44 and conductive traces 46 on its top surface. The LED array 41 comprises a plurality of LED chips 48 each of which is mounted to a respective one of the die pads 44 using COB techniques. That is, the LED chips 48 are not included in their own package, with the package then mounted to the board (e.g. surface mounted). Instead, the LED chips 48 are mounted directly to die pads 44 on the board, with this COB arrangement providing the advantages discussed above.

[0061] In some embodiments, wire bonds can be included that pass between the conductive traces 46 and each of the LED chips 48 with an electrical signal applied to each of the LED chips 48 through its respective one of the die pads 44 and the wire bonds. In other embodiments, LED chips 48 may comprise coplanar electrical contacts on one side of the LED (bottom side) with the majority of the light emitting surface being located on the LED side opposing the electrical contacts (upper side). Such flip-chip LEDs can be mounted onto the board 42 by mounting contacts corresponding to one electrode (anode or cathode, respectively) onto the die pad 44. The contacts of the other LED electrode (cathode or anode, respectively) can be mounted to the traces 46.

[0062] In the embodiment shown, the LED array 41 comprises twelve individual LED chips 48, but it is understood that other embodiments can have fewer or more LED chips. The LED chips 48 are also arranged in three sub-groups of four LED chips 48 each, with the sub-groups electrically interconnected by the traces 46. It is understood that other embodiments can comprise different numbers of sub-groups having different numbers of LED chips interconnected in different ways. It is also understood that other embodiments can comprise only individual interconnected LED chips, or combinations of individual LED chips and sub-groups of LED chips.

[0063] In the embodiment shown, the LED chips 48 can be connected in series such that an electrical signal applied to first and second wire bond pads 49a, 49b conducts to all the LED chips and causes them to emit light. The sub-groups of LED chips are connected in series and the LED chips within the sub-groups are connected in series. It is understood, however, that in other embodiments some or all of the LED chips can be connected in parallel between the contacts, while in other embodiments the LED chips can be interconnected in different series and parallel combinations. These different combinations can comprise separate LED chip circuits that can be driven by their own separate drive signal. This allows for the intensity of the different circuits to be individually controlled to control the LED component's emission color and intensity. In these embodiments, more than two wire bond pads can be included to accommodate more than one drive signal. The first and second wire bond pads 49a, 49b should be sized to allow convenient and reliable wire bond attachment, with some

embodiments having a surface area greater than 3mm^2 , while in other embodiments the surface area can be greater than 6mm^2 .

[0064] LEDs chips 48 can have many different semiconductor layers arranged in different ways and can emit many different colors in different embodiments according to the present invention. Many different commercially available LED chips can be used, including but not limited to the EZ LED chip commercially available from CREE, Inc. LED structures, features, and their fabrication and operation are generally known in the art and only briefly discussed herein.

[0065] The layers of the LEDs chips 48 can be fabricated using known processes with a suitable process being fabrication using metal organic chemical vapor deposition (MOCVD). The layers of the LED chips generally comprise an active layer/region sandwiched between first and second oppositely doped epitaxial layers all of which are formed successively on a growth substrate. LED chips can be formed on a wafer and then singulated for mounting in a package. It is understood that the growth substrate can remain as part of the final singulated LED or the growth substrate can be fully or partially removed.

[0066] It is also understood that additional layers and elements can also be included in the LED chips 48, including but not limited to buffer, nucleation, contact and current spreading layers as well as light extraction layers and elements. The active region can comprise single quantum well (SQW), multiple quantum well (MQW), double heterostructure or super lattice structures. The active

region and doped layers may be fabricated from different material systems, with preferred material systems being Group-III nitride based material systems. Group-III nitrides refer to those semiconductor compounds formed between nitrogen and the elements in the Group III of the periodic table, usually aluminum (Al), gallium (Ga), and indium (In). The term also refers to ternary and quaternary compounds such as aluminum gallium nitride (AlGaN) and aluminum indium gallium nitride (AlInGaN). In a preferred embodiment, the doped layers are gallium nitride (GaN) and the active region is InGaN. In alternative embodiments the doped layers may be AlGaN, aluminum gallium arsenide (AlGaAs) or aluminum gallium indium arsenide phosphide, aluminum indium gallium phosphide or Zinc Oxide

[0067] The growth substrate can be made of many materials such as silicon, glass, sapphire, silicon carbide, aluminum nitride (AlN), gallium nitride (GaN), with a suitable substrate being a 4H polytype of silicon carbide, although other silicon carbide polytypes can also be used including 3C, 6H and 15R polytypes. Silicon carbide has certain advantages, such as a closer crystal lattice match to Group III nitrides than sapphire and results in Group III nitride films of higher quality. Silicon carbide also has a very high thermal conductivity so that the total output power of Group-III nitride devices on silicon carbide is not limited by the thermal dissipation of the substrate (as may be the case with some devices formed on sapphire). SiC substrates are available from Cree Research, Inc., of Durham, North Carolina and methods for producing them are set forth in the scientific literature as well as in a U.S. Patents, Nos. Re. 34,861; 4,946,547; and 5,200,022.

[0068] The LED chips 48 can also comprise a conductive current spreading structure and wire bond pads on the top surface, both of which are made of a conductive material and be deposited using known methods. Some materials that can be used for these elements include Au, Cu, Ni, In, Al, Ag or combinations thereof and conducting oxides and transparent conducting oxides. The current spreading structure can comprise conductive fingers arranged in a grid on the LED chips 48 with the fingers spaced to enhance current spreading from the pads into the LED's top surface. In operation, an electrical signal is applied to the pads through a wire bond as described below, and the electrical signal spreads through the fingers of the current spreading structure and the top surface into the LED chips 48. Current spreading structures are often used in LEDs where the top surface is p-type, but can also be used for n-type materials .

[0069] Some or all of the LED chips 48 can be coated with one or more phosphors with the phosphors absorbing at least some of the LED light and emitting a different wavelength of light such that the LED emits a combination of light from the LED and the phosphor. As described in detail below, in one embodiment according to the present invention at least some of the LED chips can comprise an LED that emits light in the blue wavelength spectrum with its phosphor absorbing some of the blue light and re-emitting yellow light. These LED chips 48 emit a white light combination of blue and yellow light or a non-white light combination of blue and yellow light. As used herein, the term "white light" refers to light that is perceived as white and is within 7 MacAdam ellipses of the black body

locus on a 1931 CIE chromaticity diagram and has a CCT ranging from 2000 K to 10,000 K. In one embodiment the phosphor comprises commercially available YAG:Ce, although a full range of broad yellow spectral emission is possible using conversion particles made of phosphors based on the $(\text{Gd}, \text{Y})_3(\text{Al}, \text{Ga})_5\text{O}_{12}:\text{Ce}$ system, such as the $\text{Y}_3\text{Al}_5\text{O}_{12}:\text{Ce}$ (YAG). Other yellow phosphors that can be used for white emitting LED chips include:

$\text{Tb}_{3-x}\text{RE}_x\text{O}_{12}:\text{Ce}$ (TAG) ; RE=Y, Gd, La, Lu; or
 $\text{Sr}_{2-x-y}\text{Ba}_x\text{Ca}_y\text{SiO}_4:\text{Eu}$.

[0070] In some embodiments others of LED chips 48 can comprise blue emitting LED coated by other phosphors that absorb blue light and emit yellow or green light. Some of the phosphors that can be used for these LED chips include:

YELLOW/GREEN

$(\text{Sr}, \text{Ca}, \text{Ba}) (\text{Al}, \text{Ga})_2\text{S}_4:\text{Eu}^{2+}$
 $\text{Ba}_2(\text{Mg}, \text{Zn})\text{Si}_2\text{O}_7:\text{Eu}^{2+}$
 $\text{Gd}_{0.4}\text{Sr}_{0.6}\text{Sr}_{0.31}\text{Al}_{1.23}\text{O}_x\text{F}_{1.38}:\text{Eu}^{2+0.06}$
 $(\text{Ba}_{1-x-y}\text{Sr}_x\text{Ca}_y)\text{SiO}_4:\text{Eu}$
 $\text{Ba}_2\text{SiO}_4:\text{Eu}^{2+}$

[0071] The LED chips 48 emitting red light can comprise LED structures and materials that permit emission of red light directly from the active region. Alternatively, in other embodiments the red emitting LED chips 48 can comprise LEDs covered by a phosphor that absorbs the LED light and emits a red light. Some phosphors appropriate for this structures can comprise:

RED

$\text{Lu}_2\text{O}_3:\text{Eu}^{3+}$

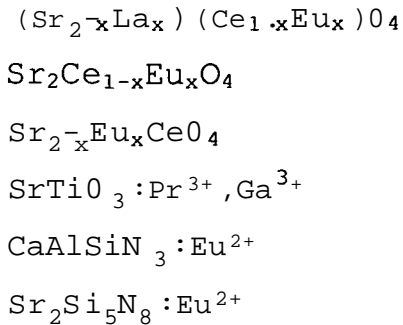

[0072] Each of the phosphors described above exhibits excitation in the desired emission spectrum, provides a desirable peak emission, has efficient light conversion, and has acceptable Stokes shift. It is understood, however, that many other phosphors can be used in combination with other LED colors to achieve the desired color of light.

[0073] The LED chips 48 can be coated with a phosphor using many different methods, with one suitable method being described in U.S. Patent Applications Serial Nos. 11/656,759 and 11/899,790, both entitled "Wafer Level Phosphor Coating Method and Devices Fabricated Utilizing Method", and both of which are incorporated herein by reference. Alternatively the LEDs can be coated using other methods such as electrophoretic deposition (EPD), with a suitable EPD method described in U.S. Patent Application No. 11/473,089 entitled "Close Loop Electrophoretic Deposition of Semiconductor Devices", which is also incorporated herein by reference. It is understood that LED packages according to the present invention can also have multiple LEDs of different colors, one or more of which may be white emitting.

[0074] The die pads 44 and conductive traces 46 can comprise many different materials such as metals or other

conductive materials. In one embodiment they can comprise copper deposited using known techniques such as plating and can then be patterned using standard lithographic processes. In other embodiments the layer can be sputtered using a mask to form the desired pattern. In some embodiments according to the present invention some of the conductive features can include only copper, with others of the features including additional materials. For example, the die pads 44 can be plated or coated with additional metals or materials to make them more suitable for mounting of LEDs. In one embodiment the die pads 44 can be plated with adhesive or bonding materials, or reflective and barrier layers. The LEDs can be mounted to the die pads 44 using known methods and materials such as using conventional solder materials that may or may not contain a flux material or dispensed polymeric materials that may be thermally and electrically conductive. The die attach pads 44 can also be mounted directly to the board 42, or intervening layers can be included, such as layers to provide improved adhesion between the attach pads 44 and board. The conductive traces 46 can pass under the die attach pads to enhance electric connection between the two.

[0075] The LED component and its array can have many different shapes and sizes, with the LED component 40 having a generally oblong shape to accommodate the first and second wire bond pads 49a, 49b. Other embodiments of the LED component can have different shapes such as circular, oval, square, rectangular or triangular. The LED component 40 is referred to as compact because of its generally small size for this number of LED chips and light output characteristics. In the embodiment shown, the LED

component can have a distance across the board (e.g. diameter for circular boards) that is in the range of 5-50 mm. In other embodiments the distance across can be in the range of 10-30mm. In some embodiments the distance can be approximately 18.5 mm, while in other embodiments it can be approximately 15 mm. In the oblong embodiment shown, the LED component can be approximately 15mm by 16mm.

[0076] The board 42 can be formed of many different materials that can be arranged to provide the desired electrical isolation and high thermal conductivity. In some embodiments, the board 42 can at least partially comprise a dielectric to provide the desired electrical isolation. In other embodiments the board 42 can comprise ceramic such as alumina, aluminum nitride, silicon carbide, or a polymeric material such as polyimide and polyester etc. For boards made of materials such a polyimides and polyesters, the boards can be flexible. This can allow the boards to take a non-planar or three-dimensional shape, with the LED chips also being arranged in a non-planar manner. This can assist in providing boards that emit the different light patterns, with the non-planar shape allowing for a less directional emission pattern. In some embodiments, this arrangement can allow for more omnidirectional emission, such as in the 0-180° emission angles.

[0077] In other embodiments the board 42 can comprise highly reflective material, such as reflective ceramic or metal layers like silver, to enhance light extraction from the component. In other embodiments the submount 42 can comprise a printed circuit board (PCB), sapphire, silicon carbide or silicon or any other suitable material, such as

T-Clad thermal clad insulated substrate material, available from The Bergquist Company of Chanhassen, Minn. For PCB embodiments different PCB types can be used such as standard FR-4 PCB, metal core PCB, or any other type of printed circuit board. The board can also be fabricated using known prepreg materials and techniques. The size of the submount 42 can vary depending on different factors, with one being the size and number of LED chips 48.

[0078] In some embodiments that board 42 can comprise a dielectric layer 50 to provide electrical isolation, while also comprising electrically neutral materials that provide good thermal conductivity. Different dielectric materials can be used for the dielectric layer including epoxy based dielectrics, with different electrically neutral, thermally conductive materials dispersed within it. Many different materials can be used, including but not limited to alumina, aluminum nitride (AlN) boron nitride, diamond, etc. Different boards according to the present invention can provide different levels of electrical isolation with some embodiments providing electrical isolation to breakdown in the range of 100 to 5000 volts. In other embodiments, the board can provide electrical isolation in the range of 1000 to 3000 volts. In still other embodiments, the board can provide electrical isolation of approximately 2000 volts breakdown. The boards according to the present invention can provide different levels of thermal conductivity, with some having a thermal conductivity in the range of 1-40 w/m/k. In other embodiments, the board can have a thermal conductivity of larger than 10 w/m/k. In still other embodiments, the board can have a thermal conductivity of approximately 3.5 W/m-k.

[0079] The dielectric layer can have many different thicknesses to provide the desired electrical isolation and thermal conductivity characteristics, such as in the range of 10 to 100 micro meters (μm). In other embodiments, the dielectric layer can have a thickness in the range of 20 to 50 (μm). In still other embodiments, the dielectric layer can have a thickness of approximately 35 (μm).

[0080] The board 42 can also comprise a base plate 52 on the dielectric layer 50, opposite the LED array, and can comprise a thermally conductive material to assist in heat spreading. The base plate can comprise different material such as copper, aluminum or aluminum nitride. The base plate can have different thicknesses, such as in the range of 100 to 2000 μm , while other embodiments can have a thickness in the range of 200 to 1000 μm . Some embodiments can have thickness of approximately 500 μm .

[0081] In some embodiments, the board 42 can also comprise a solder mounting layer (not shown) on the bottom surface of the base plate 52 that is made of materials that make it compatible for mounting directly to a heat sink, such as by solder reflow. These materials can comprise one or more layers of different metals such as nickel, silver, gold, palladium. In some embodiments, the mounting layer can comprise a layer of nickel and silver, such a nickel having thickness in the range of 2 to 3 μm and silver in the range of 0.1 to 1.0 μm . In other embodiments, the mounting layer can comprise other layer stacks such as electroless nickel of approximately 5 μm , electroless palladium of approximately 0.25 μm , and immersion gold of approximately 0.15 μm . Direct soldering of a board to a heat sink can

enhance thermal spreading of heat from the board to the heat sink by providing an increased thermal contact area between the two. This can enhance both vertical and horizontal heat transfer. The different boards according to the present invention can provide different levels of thermal characteristics with a junction to backside performance of approximately of approximately 0.4 °C/W.

[0082] The electrical isolation for the LED chips is not only provided by the isolation characteristics of the board 42, but can also be provided by an offset from the edge of the board. The offset provides a certain distance between the outside edge of the LED array 41 and the edge of the board 42. In some embodiments it can be offset a distance in the range of 0.5 to 5 mm. In still other embodiments it can be offset in the range of 1 to 2mm. In some embodiments the array is offset from the edge of the board by approximately 1.5mm. Use of the COB mounting techniques with individual LED chips can still allow for an LED component despite the additional need for a setback. The LED chips can be mounted on an area of the board that takes into account the offset; i.e., the offset results in a smaller board area for the LED chips. In the embodiment shown, the setback results on a board area of approximately 12mm for the LED chips.

[0083] To further enhance thermal management, the die attach pads can be larger than the actual LED chips 48, having an extension portion 56 that extends beyond the LED chip edge. This can allow for the heat from the LED chips to spread into a larger area through the thermally conductive die attach pad, where the heat can then spread

into a larger area of the board 42. Different embodiments of the die attach pads can extend beyond the LED chip edge different distances. In some embodiments it can extend a distance in the range of 25 to 500 μm , while in other embodiments it can extend a distance in the range of 70 to 210 μm .

[0084] Pursuant to another aspect of the present invention, a primary element/lens 55 is included over each of the sub-groups of LED chips 48 to provide both environmental and mechanical protection. Each primary lens 55 comprises a material substantially transparent to the light from the LED chips 48 it is covering and each primary lens 55 can also be shaped to provide for an increase in first pass emission from the LED lens. That is, the lens surface is such that light from the LED sub-group strikes the surface of the lens within the critical angle to allow the light to pass out of the lens. The primary lenses can be shaped and arranged so that the majority of light from the LEDs strikes the lens surface within the critical, with a smaller amount of light striking outside the critical. This can reduce the amount of light that is absorbed when reflected back toward absorbing features of the LED component and reduces the amount of light that can be lost to total internal reflection (TIR).

[0085] Each of the primary lenses 55 can be in different locations on the top of their respective sub-groups with each of the lenses typically mounted over the center of its subgroup. In some embodiments the lens 55 can be formed in direct contact with the LED chips 48 and the top surface of the board 42 around the LED chips. In other embodiments

there may be an intervening material or layer between the LED chips 48 and the sub mount's top surface. Direct contact to the LED chips 48 can provide certain advantages such as improved light extraction and ease of fabricating.

[0086] The primary lenses 55 can be formed over the LED chips 48 using different molding techniques and the lens 55 can be many different shapes depending on the desired shape of the light output. One suitable shape as shown is hemispheric, with some examples of alternative shapes being ellipsoid bullet, flat, hex-shaped and square. Many different materials can be used for the lens such as silicones, plastics, epoxies or glass, with a suitable material being compatible with molding processes. Silicone is suitable for molding and provides suitable optical transmission properties. It can also withstand subsequent reflow processes and does not significantly degrade over time. It is understood that the lenses 55 can also be textured to improve light extraction or can contain conversion materials (e.g. phosphors) or scattering particles .

[0087] The lenses 55 are shown with no lens material on the top surface of the board 42 between adjacent lenses. In some embodiments and layer of lens material can be left on the top surface of the board 42 for ease of manufacturing, particularly when the lenses are molded in place. This layer of lens material can take many different shapes around to the lenses 55 and can have different thicknesses.

[0088] The lens 55 can be formed using other methods, such as dispensing the lens material in liquid form over the LED chips 48, and then curing the lens material. In some

embodiments the LED component 40 can comprise meniscus features around each LED chip, although it is understood that the dispense method can also be used without the features. The meniscus features form a meniscus with the lens material as it is dispensed in liquid form over the LED chips, with the meniscus holding the lens material in a substantially dome-shape. The lens material can then be cured, forming each of the lenses 55 over its LED chips 48. This meniscus lens formation method and related meniscus features are described in U.S. Patent Application Serial Number 11/398,214, entitled "Uniform Emission LED Package," which is incorporated herein by reference.

[0089] The lenses 55 can be sized to completely cover all of the die attach pad 44 for its one of the LED chips 48, or the lenses can cover only portions of the die attach pad 44. The lenses 55 can also cover some of the conductive traces 46 while portions of the conductive traces can be uncovered by the optics. The lenses can also have a size and location such that the wire bond pads 49a, 49b are uncovered by the lenses, while in other embodiments the lenses can cover portions of the bond pads 49a, 49b, while leaving enough of the bond pads uncovered for connection of wires to the bond pads 49a, 49b. The LED component 40 can also comprise a reflective layer on the top surface of the board as described below.

[0090] The emission efficiency of the LED components according to the present invention can also be improved by maximizing the distance between adjacent primary lenses to avoid potential optical cross-talk between light emitting from adjacent LED sub-groups. Optical cross-talk can occur

when light emitting from one lens passes into another lens. A portion of this light can be reflected within the lens and lost due to absorption or TIR. The further the lenses are apart the less likely that light from one can "cross-talk" or spread into another. Accordingly, the space between adjacent ones of the lenses can be maximized while still keeping the LED chips 48 in a compact arrangement on the board 42 with the desired setback. In different embodiments, the primary lens 55 can have many different sizes, depending at least partially on the size of the LED chips 48. In some embodiments the lens 55 can have a diameter that is greater than 2mm, while in other embodiments that lens 55 can have a diameter greater than 5mm. In one embodiment, the lens has a diameter that is approximately 5.5mm.

[0091] Providing LED chips 48 in sub-groups with primary optics can provide additional efficient advantages compared to singular LED chips with primary optics. The greater the numbers of LED chips that can have a periphery emission path, the greater the amount of light that can emit without the danger of cross-talk. That is, the more LED chips at the periphery a greater percentage of light is generated with a path to the edge of the board without passing through an adjacent lens. A combination of maximum distance between adjacent lenses and maximum periphery exposure can result in increased emission efficiency. By having the LED chips arranged at or near the periphery can also assist in thermal spreading by allowing for an efficient path for heat to spread to the board edge.

[0092] Different embodiments of the LED components can provide different operating characteristics depending at least partially on the number and type of LED chips. Some embodiments can operate from input power in the 10-30 watt range. Some embodiments operate from input power of greater than 10W, while other embodiments can operate from input power of greater than 15W. Some embodiments can provide illumination of greater than 500 lumens while others can provide illumination of greater than 700 lumens. These operating characteristics can be provided while still maintaining the LED chip array within a 12mm envelope on the board.

[0093] The LED components as well as these operating characteristics are scalable such that the LED components according to the present invention can have 3 chips up to 10s or 100s of LED chips. The board would likewise need to be larger and may be constrained by the operating parameters, but the optical and thermal arrangements of the LED chips according to the present invention allow for scalability to these embodiments having larger numbers of LED chips. These different arrangements can utilize input power of as little as 3 to 100s of watts.

[0094] It is understood that the LED component 40 as well as the embodiments described below, can have many different features beyond those described herein. For example, different embodiments can comprise features or devices that protect the LED chips from electro-static discharge (ESD) damage. In some embodiments these can comprise ESD protection devices associated with and protecting each of the LED chips or can comprise ESD protection devices

†

associated with and protecting a plurality of LED chips. In some embodiments the ESD protection device can comprise one or more diodes, each of which is arranged adjacent and electrically coupled to the one LED chip, or plurality of LED chips, it is protecting. In some embodiments, the ESD protection devices can comprise Zener diodes.

[0095] Additional circuits or electrical components can also be included on the board 42 for providing the desired drive signal or protection to the LED chips 48. These can include many different types of circuits, with one being a current compensation circuit. For LED components having LED chips emitting different colors of light, the LED chips can have different characteristics over time and in response to heat. For example, LED components incorporating both red and blue LEDs can be subject to color instability with different operating temperatures and dimming. This can be due to the different behaviors of red and blue LEDs at different temperature and operating power (current/voltage), as well as different operating characteristics over time. This effect can be mitigated somewhat through the implementation of an active control and compensation system. In some embodiments the control and compensation system can reside on the same circuit board as the LED chips, providing a compact and efficient lighting and compensation system.

[0096] Referring now to FIG. 5, the LED component 40 can also be mounted to a heat sink 60, such as by a thermal connection between the board 42 and the heat sink 60. As mentioned above, the board 42 can have a layer that is compatible with solder mounting techniques, such as by

reflow. The solder between board 42 and the heat sink provides an efficient thermal path to spread heat from the LED chips, with the board's dielectric layer providing the desired electrical isolation. The heat sink can comprise first and second wire holes 62a, 62b that allow wires (not shown) to pass through from the backside of the heat sink for bonding to the first and second wire bond pads 49a, 49b.

[0097] LED components according to the present invention can also be mounted to heat sink using mechanical means such as screws, rivets, brackets, twist locks, etc. FIG. 6 shows the LED component 40 mounted to a heat sink 60 by first and second screws 64a, 64b. In the embodiment shown utilizes industry designated M2 screws, and pursuant to some current standards, M2 screws can be used that are the smallest screw used in LED lighting applications. Accordingly, the LED chips must be arranged to provide space to accommodate the screw and its head. Clustering the LED chips 48 in sub-groups can help provide unused areas of the board 42 between the sub-groups for the screw heads. The screws 64a, 64b along with the contact between the LED component and the heat sink provide the thermally conductive paths to spread heat from the LED chips into the heat sink.

[0098] As mentioned above, different embodiments of LED components according to the present invention can have different numbers of LED chips arranged in different ways. FIG. 7 shows another embodiment of an LED component 80 according to the present invention that is similar to the LED component 40 described above. The LED component 80

comprises 16 LED chips 82 mounted to a board 84 with the LEDs chips 82 and board being similar to those described above. In this embodiment, the LED chips 82 can be clustered in four sub-groups 86 of four LED chips. The LED chips 82 can be interconnected by wire traces in different serial and parallel arrangements. This is only one of the many alternative ways that LED chips can be arranged in sub-groups according to the present invention.

[0099] As also mentioned above, the LED components can be arranged with individual LED chips, each of which has its own primary optic or lens, In still other embodiments LED components can be provided having different combinations of single and clustered LED chips each of which has its own primary lens.

[00100] FIGs. 8 through 13 show another embodiment of an LED component 100 according to the present invention having 12 LED chips 102 mounted to a board 104 using COB techniques as described above. The LED chips 102 and board 104 can have many of the same or similar features of the LED chips and boards described above. In particular the board 104 can have the same electrical isolation and thermal conductivity characteristics of the board 42 described above.

[00101] In this embodiment the LED chips 102 are not clustered in sub-groups, but are instead provided as individual LED chips each having their own primary lens 106. Similar to the embodiment above, the LED chips 102 are mounted on die attach pads and interconnected by conductive traces. Lenses 106 can have many different shapes and sizes as described above, but are preferably hemispheric shaped. The lenses 106 can all be the same size

or can comprise different sizes. In some embodiments, the lenses can have a diameter that is greater than 1mm, while in other embodiments they can have a diameter greater than 2mm. In one embodiment, the lenses can have a diameter of approximately 2,55mm. As above, the LED chips and their lenses should have maximum distance between adjacent ones for improved thermal management and reduced optical cross-talk.

[00102] The LED chips 102 can be provided in different patterns to maximize the distances while still providing the desired operating characteristics. In the embodiment shown the LED chips 102 are provided in a pattern of two concentric circles of LED chips, which can help maximize the distance between adjacent LED chips. The LED chips can be interconnected in different series and parallel arrangements as described above, with the embodiment shown being interconnected in a zig-zag pattern as best shown in FIGs. 8 and 9. First and second wire bond pads 107a, 107b can be included on the board to allow an electrical signal to be applied to the board that spreads to each of the LED chips through the conductive traces and die attach pads as described above. The die attach pads can also have extension sections that extend beyond the edge of the LED chip to improve heat spreading from the LED chip as described above.

[00103] The zig-zag pattern of the LED chips 102 also allows for the board to remain "compact" by fitting the LED chips into a relatively small board area. In the embodiment shown, the board 104 is shown as circular, but it is understood that the board can have many different shapes.

Like the embodiment above, the LED chips 102 can have a setback from the edge of the board to provide the desired electrical isolation. In some embodiments it can be offset a distance in the range of 0.5 to 5 mm. In still other embodiments it can be offset in the range of 1 to 2mm. In some embodiments the array is offset from the edge of the board by approximately 1.5mm. In the embodiment shown, the LED component is circular and can have a diameter that is in the range of 5-50 mm. In other embodiments the diameter can be in the range of 10-30mm, In the embodiment shown the LED component can have a diameter of approximately 15mm, with the electric isolation offset providing an area or envelope on the board of approximately 12mm for the LED chips .

[00104] The zig-zag arrangement with concentric circles not only allows for compact placement of the LED chips 102 on the board 104, it can also allow for an increase in LED light that can emit to the periphery of the board without encountering or passing through the lens of an adjacent LED chip. In the embodiment shown, the LED chips of the outer circle are staggered to the LED chips in the inner circle such that each of the outer circle LED chips is adjacent the space between LED chips in the inner circle. This can increase the amount of light from the inner circle LED chips that can pass to the board periphery between the LED chips in the outer circle.

[00105] The board 104 can also have one or more cutouts or notches 105 on its edge that are sized to allow wires to pass from one side of the board 104 to the opposite side. In the embodiment shown, the board 104 has two notches 105

on opposing sides of the board, so that two wires can pass from the backside to the top of the board, where the wires can be connected to the wire bond pads 107a, 107b. This allows from an electrical signal to pass from the backside to the front side of the board 104, to be applied to the bond pads for driving the LED chips 102.

[00106] Referring now to FIG. 14, the LED component 100 can be mounted to a heat sink 120 to help spread heat from the LED chips 102. Like the embodiment discussed above, the board 104 can have a layer that is compatible with solder reflow techniques. The solder between board 104 and the heat sink 120 provides an efficient thermal path to spread heat from the LED chips, with the board's dielectric layer providing the desired electrical isolation. Soldering also allows for mounting of the board without using areas of the board for mechanical mounting means, which can help the board remain more compact. The heat sink 120 can comprise first and second wire holes 122a, 122b that allow wires (not shown) to pass through from the backside of the heat sink for bonding to the first and second contacts wire bond pads. As mentioned above, the LED components according to the present invention can take many different shapes and sizes, with the LED component being oblong and having a size of approximately 15mm by 16mm.

[00107] Like the embodiment above, the LED component 100 can also be mounted to heat sink using mechanical means such as screws, rivets, brackets, twist locks, etc. FIG. 15 shows the LED component 100 mounted to a heat sink 130 by first, second and third mounting screws 132a, 132b, 132c. The mounting screws can be many different shapes and sizes,

with the embodiment shown using industry standard M2 screws. Accordingly, the LED chips 102 and their primary lenses must be arranged to provide space to accommodate the screw and its head. Arranging the LED chips in the inside and outside circles, space is provided between the LED chips in the outside circle. Different numbers of screws can be used, with the embodiment shown having three mounting screws 132a, 132b, 132c spaced approximately 120° apart. Notwithstanding the spacing of the LED chips 102, the LED component 100 used with mechanical mounts may need to be larger to accommodate the screw heads. In the embodiment shown, the LED component 100 can have a diameter greater than approximately 18mm and in some embodiments can have a diameter of approximately 18.5mm. The screws 132a, 132b, 132c along with the heat contact/radiation between the LED component and the heat sink provide the thermally conductive paths to spread heat from the LED chips into the heat sink. The LED component can also have first and second side slots 134a, 134b to allow wires to pass for attachment to the first and second wire bond pads.

[00108] FIG. 16 and 17 show another embodiment of an LED component 150 having an array of LED chips 152 arranged in a rectangular formation on a board 154. The board 154 can have the same characteristics as the board's above and in particular the thermal and electrical characteristics. The LED chips 152 can be mounted on the board 154 using COB techniques and can be connected in series between first and second wire bond pads 156a, 156b such that when an electrical signal is applied to the contacts 156a, 156b, the LED chips emit light. Like LED component 100 described above, each of the LED chips 152 has its own primary lens

158 that is preferably hemispheric shaped and arranged to promote first pass LED chip emission from the lens. This arrangement is more compact, but fewer of the LEDs can emit to the board periphery without encountering another of the primary lenses. The LED chips are also arranged in closer proximity such that they may experience reduced emission efficiency based on increased optical cross-talk and may experience increased operating temperature. Like the embodiments above, the LED component 150 can be mounted to a heat sink using solder or other mechanical mounting techniques .

[00109] FIG. 18 shows the emission characteristic for some embodiments of an LED component according to the present invention based on normalized intensity verses viewing angle. The emission intensity of the LED components can be the greatest and a 0 degrees viewing angle and can drop off at increasing viewing angles to nominal emission at angles greater approximately 95 degrees. The beam profile shows has the advantage of being broader than Lambertian (cosine) emission characteristics.

[00110] As mentioned above, the LED components according to the present invention can have many different numbers of LED chips and furthermore, the boards' used in the different embodiments can have different shapes and sizes. FIGs. 19 through 21 show another embodiment of and LED component 200 according to the present invention having eight LED chips 202 mounted on a generally square or rectangular shaped board 204, also using COB techniques. The LED chips 202 can be mounted to die attach pads 206 interconnected in series between first and second wire bond

pads 208a, 208b by conductive traces 210. The board 204 can also comprise notches 205, sized to allow wires to pass from one side of the board 204 to the other. It is understood that the LED chips can also be arranged in different series and parallel interconnection arrangements.

[00111] The LED chips 202 are positioned in a circle to provide an unobstructed path to the periphery of the board for each of the LED chips and to provide improved heat spreading to the edge of the board. Each of the LED chips 202 also has its own primary lens 212 to enhance first pass light extraction as described above, with the lenses preferably being hemispheric shaped. The board 204 can have many of the same electrical and thermal characteristics as the boards discussed above, but because of the reduced number of LED chips 202, the board 204 can be smaller. Some embodiments can have sides greater than 10mm, while other embodiments can have sides greater than 12mm. In the embodiment shown, the board can be 13.5mm by 12.15mm.

[00112] The die attach pads 206 can be arranged to hold different sized LED chips, with the embodiment shown arranged to accommodate 1.4 mm sized LED chips. The die attach pads 206 also extend beyond the LED chip edges to facilitate heat spreading, with the die attach pads 206 shown extending from three edges of the LED chip, with one edge extending to the center of the board.

[00113] FIG. 22 shows still another embodiment of an LED component 230 according to the present invention that is similar to the LED component 200 and comprises LED chips 232 mounted to board 234, also using COB techniques. The LED chips are mounted on die attach pads 236 that also

extend beyond the edges of the LED chips in a somewhat different shape. The majority die attach extension runs closer to the periphery of the board, which can enhance heat spreading toward the edge where it can dissipate into the ambient. It is understood that the eight LED chip arrangements shown in FIGs. 19 through 22 can also be mounted to a heat sink as described above using either solder reflow or mechanical components.

[00114] FIGs. 23-27 show components and features of still another embodiment of an LED component 250 according to the present invention that is similar to the LED components described above and comprises LED chips 252 mounted to board 254, also using COB techniques. The LED chips 252 and board 254 can be made of the materials described above and can have the different features as the LED chips and boards described above. There can be different numbers of LED chips in different embodiments according to the present invention, with the embodiment shown having twelve (12) LED chips 252. As best shown in FIG. 23, the component 250 also comprises die attach pads 256 and interconnect traces 257 formed on the board 254. Each of the die attach pads is sized so that one of the LED chips 252 can be mounted to a respective one of the die attach pads. First and second wire bond pads 258a, 258b are also included on the board 254, such that when the LED chips 252 are mounted on the die attach pads 256 they are connected in series between the bond pads 258a, 258b by the interconnect traces 257. It is understood that the LED chips can also be coupled in parallel between the bond pads 258a, 258b, or can be coupled between the bond pads in different series and parallel combinations as described above. The board 254

also has a mounting hole 260 for mounting the LED component 250 in a fixture, such as by a screw (not shown) .

[00115] In this embodiment, the bond pads 258a, 258b are located on a diameter line or equator 262 of the board 254, with the mounting hole 260 between the bond pads 258a, 258b. The LED chips 252 are not found along the equator 262, but clustered above and below the equator 262, with half of the LED chips being above, and half of the LED chips being below. It is understood that different numbers of chips can be above and below in the same or different numbers, with the embodiment shown having six LED chips 252 above and six below the equator 262. Notches 264 for wires to pass are included on opposite sides of the board 254, with each one being adjacent to a respective one of the bond pads 258a, 258b. This arrangement provides for a shorter distance between the notches 264 and the bond pads 258a, 258b that allows for a wire to pass from the notch 264 to its particular one of the bond pads 258a, 258b in a straight line and at a short distance. This can provide the advantage of easier manufacturing and a more reliable wire bonding .

[00116] As best shown in FIGs . 25 through 27, each of the LED chips 252 also has its own primary lens 266 that can be formed using the methods described above. The lens 266 should be sized to cover its one of the LED chips 252 and to provide the desired light extraction. In some embodiments, the lenses can have a diameter of greater than 2mm, while in other embodiments it can have a diameter of greater than 3mm. In some embodiments it can have a diameter of approximately 3.1mm. The LED chip and lens

arrangement can provide for light extraction of greater than 90%, with some embodiments having light extraction of greater than 96%. FIGs. 25 and 26 show a layer of lens material 267 between and around the lenses 266, with the layer 267 being left behind as the result of lens fabrication process, such as molding. As mentioned above, this layer of lens material can take many different shapes and thicknesses. In some embodiments, all or some of the lenses can be provided without the surrounding layer of lens material.

[00117] Referring now to FIG. 24, the LED component 250 can further comprise a reflective layer 268 that is shown as a separate layer in FIG. 24, but is formed or placed on the top surface of the board 254 as shown in FIGs. 25 and 27. The reflective layer 268 covers most of the top surface of the board 254. This can include portions of the die attach pads 256, portions of the bond pads 258a, 258b and the interconnect traces 257 shown in FIG. 23. In the LED component as shown in FIGs. 25-27, the die attach pads and interconnect traces are covered by the reflective layer 268 and LED chips 252 are most are not visible. The bond pads 258a, 258b are visible through openings in the reflective layer 268. The reflective layer 268 covers many of the light absorption surfaces with a reflective surface that reflects LED chip light emitted back towards the board 254 so that it can contribute to the LED components useful emission .

[00118] The reflective layer 268 can comprise different reflective materials formed or deposited using known methods . In some embodiments , the reflective layer can

comprise submicron or nanometer sized particles held in a binding material. In some embodiments, the reflective layer 268 can comprise submicron or nanometer sized titanium particles in a polymer binder, such as silicone. More than one scattering material in various combinations of materials or combinations of different forms of the same material may be used to achieve a particular scattering effect. Different reflective layers can have different reflectivity, with some embodiments having a reflectivity of greater than 85%, while others have a reflectivity of greater than 95%.

[00119] The reflective layer 268 can be included as part of a solder mask, or it can be a separate layer formed on the board 254. It can be included on LED components with or without solder masks. It is also understood that a reflectivity layer and solder mask layer can be included in any of the embodiments shown in the figures and discussed above.

[00120] In the embodiment shown, the reflective layer covers the majority of the board's top surface, except the areas where the LEDs chips 252 are attached to the attach pads 256, and where the wires are attached to wire bond pads 258a, 258b. In some embodiments, there can be a gap between the edge of one or more of the LED chips 252 and the reflective layer 268, with a portion attach pad exposed between LED chips 252 and reflective layer 268. Similarly, a portion of the bond pads 258a, 258b can be exposed following wire bonding. To reduce the absorption of light that can occur on these exposed portions of the attach pads

and bond pads, they covered by reflective material such a reflective metal.

[00121] In different embodiments, the reflective layer 268 can pass under the primary lenses 266, while in other embodiments it can be outside of the lenses 266. The LED component 250 can also comprise a dielectric layer to provide electrical isolation and a heat sink as described above. Different embodiments can also comprise on-board ESD protection components and circuits as described above, as well as other types of on-board circuits such as current compensation circuits as described above. In LED component 250, an ESD protection chip can be included on ESD attach pad 270 (shown in FIG. 23), and can be coupled to the LED chip circuit to provide ESD protection.

[00122] It is understood that the LED components according to the present invention can take many different shapes beyond those described above, including but not limited to triangular, oval, rectangular, linear, etc. FIG. 28 shows one embodiment of linearly arranged LED component 280 comprising an elongated circuit board 282, with LED chips 284 and primary lenses 286 formed over the LED chips 284 using the methods described above. Wire bond pads 288a, 288b are included at the ends of the board 282, but it is understood that they could be placed in many different locations. The LED component 280 can comprise the features described above, including but not limited to, a dielectric layer, a reflective layer, an ESD protection device, and current compensation circuit. The component 280 can comprise a compact linear array of LED chips 284 that can be different lengths, from centimeters to meters long. The

LED component can be arranged at a length compatible with conventional fluorescent lamps, with the LED components be arranged as replacement bulbs for fluorescent lamps.

[00123] Different embodiments of the present invention can also be provided with secondary optics over all or some of the primary optics to provide for protection for the LED array and/or to provide for beam shaping from the LED array. The secondary optics can take many different shapes and sizes and can have additional conversion or scattering materials. FIG. 29 shows one embodiment of an LED component 300 with sub-groups of LED chips 302 mounted to a board 304 as described above. Each of the sub-groups can have its own primary lens 306, with the primary lens then covered by a hemispheric shaped secondary lens 308. FIG. 30 shows another embodiment of an LED component 320 according to the present invention also having an array of LED chips 322 on a board 324. In this embodiment each of the LED chips has its own primary lens 326 that is covered by a hemispheric shaped secondary lens 328. FIG. 31 shows still another embodiment of an LED component 340 according to the present invention that is similar to the LED component 320 but comprises a secondary optic 342 having a shape other than hemispheric. It is understood that these are only some of the different shapes for the secondary optics in LED components according to the present invention.

[00124] Although the present invention has been described in detail with reference to certain preferred configurations thereof, other versions are possible. Therefore, the spirit and scope of the invention should not be limited to the versions described above.

We Claim:

1. An LED component, comprising:
a circuit board having a plurality of die attach pads;
a plurality of LED chips, each of which is mounted on a respective one of the die attach pads; and
primary lenses, each of which is formed directly over a single one or a subgroup of said LED chips.
2. The LED component of claim 1, further comprising first and second wire bond pads, said LED chips connected in series between said wire bond pads.
3. The LED component of claim 1, wherein said circuit board is electrically insulating.
4. The LED component of claim 1, wherein said circuit board is electrically insulating up to 2000 volts.
5. The LED component of claim 1, wherein said circuit board is thermally conductive.
6. The LED component of claim 1, wherein said circuit board comprises a dielectric with one or more thermally conductive materials.
7. The LED component of claim 1, wherein said circuit board further comprises a conductive base plate.
8. The LED component of claim 1, wherein said LED chips are arranged in a plurality of sub-groups.

9. The LED component of claim 8, comprising a respective one of said primary lenses over each sub-group.
10. The LED component of claim 1, wherein said lenses are substantially hemispheric shaped.
11. The LED component of claim 1, wherein said LED chips are arranged in a circle on said circuit board.
12. The LED component of claim 1, wherein said LED chips are arranged in concentric circles.
13. The LED component of claim 12, wherein said LED chips are interconnected in a zig-zag arrangement.
14. The LED component of claim 1, wherein said LED chips are set-back from the edge of said circuit board.
15. The LED component of claim 1, wherein said LED chips are mounted on said die attach pads using chip-on-board techniques .
16. The LED component of claim 1, wherein said primary optics are molded over said LED chips.
17. The LED component of claim 1, further comprising a heat sink to spread heat from said component.
18. The LED component of claim 1, further comprising secondary optics.

19. The LED component of claim 1, further comprising a reflective layer on the top surface of said circuit board.

20. The LED component of claim 19, wherein said reflective layer covers at least a portion of said die attach pads.

21. The LED component of claim 20, wherein said reflective layer extends under one or more of said primary lenses.

22. The LED component of claim 1, wherein each of said primary lenses covers all of the die attach pad(s) from its one or a subgroup of said LED chips.

23. The LED component of claim 1, wherein each of said primary lenses covers less than all of the die attach pad(s) from its one or subgroup of LED chips.

24. The LED component of claim 1, wherein said LED chips are in a linear array.

25. The LED component of claim 1, wherein said circuit board is elongated and said LED chips are in a linear array.

26. The LED component of claim 1, further comprising conductive traces running between said die attach pads.

27. The LED component of claim 1, wherein said LED chips emit more than one color of light.

28. An LED component, comprising:

a circuit board with an array of LED chips mounted on it and electrically interconnected;

a plurality of primary lenses, each of which is formed directly over a single one or a sub-group of said LED chips;

a heat sink, said circuit board mounted to said heat sink so that heat from said LED chips spreads into said heat sink.

29. The LED component of claim 28, wherein said circuit board is thermally conductive.

30. The LED component of claim 28, wherein said circuit board is electrically insulating.

31. The LED component of claim 28, wherein said circuit board comprises a layer and/or layers of material compatible with soldering.

32. The LED component of claim 28, wherein said circuit board is soldered to said heat sink.

33. The LED component of claim 28, wherein said circuit board is mechanically mounted to said heat sink.

34. The LED component of claim 28, wherein said circuit board further comprises a reflective layer.

35. A solid state lighting component, comprising:

a circuit board that is thermally conductive and electrically insulating;

a plurality of LED chips, each of which is chip-on-board mounted on a respective one of the die attach pads; and

a plurality of primary lenses, each of which is formed directly over a single one or a subgroup of said LED chips.

36. The lighting component of claim 35, wherein said circuit board comprises a dielectric with one or more thermally conductive materials.

37. The lighting component of claim 35, wherein said circuit board further comprises a conductive base plate.

38. The lighting component of claim 35, wherein said LED chips are arranged in a plurality of sub-groups.

39. The lighting component of claim 38, comprising a respective one of said primary lenses over each sub-group.

40. The lighting component of claim 35, wherein said lenses are substantially hemispheric shaped.

41. The lighting component of claim 35, wherein said LED chips are arranged in a circle on said circuit board.

42. The lighting component of claim 35, wherein said LED chips are arranged in concentric circles.

43. The lighting component of claim 35, wherein said LED chips are arranged in groups in different portion of said circuit board.

44. The lighting component of claim 35, wherein said LED chips are arranged with one group in one half of said board, and another group in the other half of said board.

45. The lighting component of claim 35, wherein said LED chips are set-back from the edge of said circuit board.

46. The lighting component of claim 35, further comprising a heat sink to spread heat from said component.

47. The lighting component of claim 35, further comprising secondary optics.

48. A method of forming an LED component, comprising:
providing a circuit board;
chip-on-board mounting LED chips on said circuit board with said LED chips electrically interconnected; and
molding primary lenses directly over each of said LED chips and sub-groups of said LED chips.

49. The method of claim 48, wherein said LED chips are arranged in sub-groups, further comprising molding primary lenses over each of said sub-groups.

50. The method of claim 48, comprising forming primary lenses over each of said LED chips.

51. The method of claim 48, further comprising forming conductive elements to interconnect said LED chips.

52. An LED component, comprising:
a circuit board;

a plurality of LED chips, mounted on said circuit board;

a primary optic over a single one or a subgroup of said LED chips; and

a secondary optic over said primary optic.

53. The LED component of claim 52, wherein said primary lens is directly over said single one or subgroup of said LED chips.

54. The LED component of claim 52, wherein said secondary lens is directly over said primary lens.

55. The LED component of claim 52, wherein said secondary optic provide for beam shaping of light from said LED chips .

56. The LED component of claim 52, wherein said secondary optics comprises conversion or scattering materials.

57. The LED component of claim 52, wherein said secondary optics are hemispheric shaped.

58. An LED component, comprising:

a circuit board;

a plurality of LED chips, mounted on said circuit board;

a plurality of primary optics, each of which is over a single one or a subgroup of said LED chips; and

a secondary optic over said primary optics.

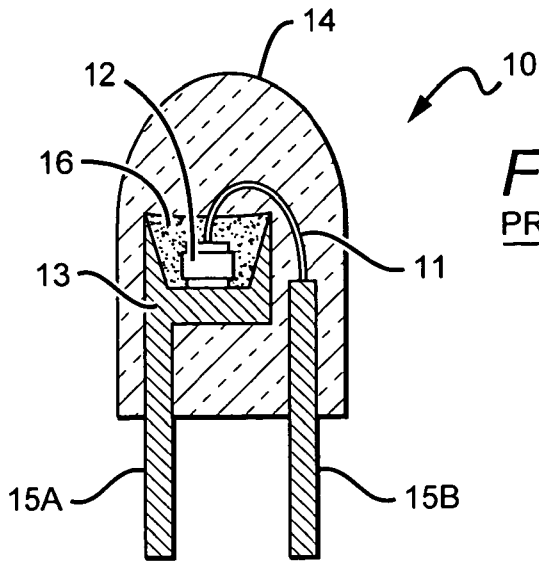

FIG. 1
PRIOR ART

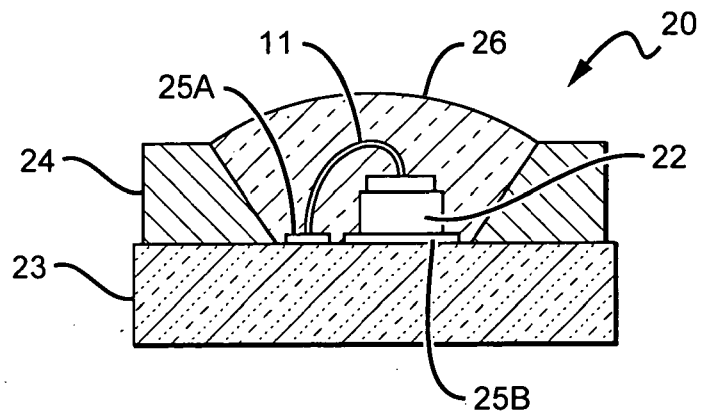

FIG. 2
PRIOR ART

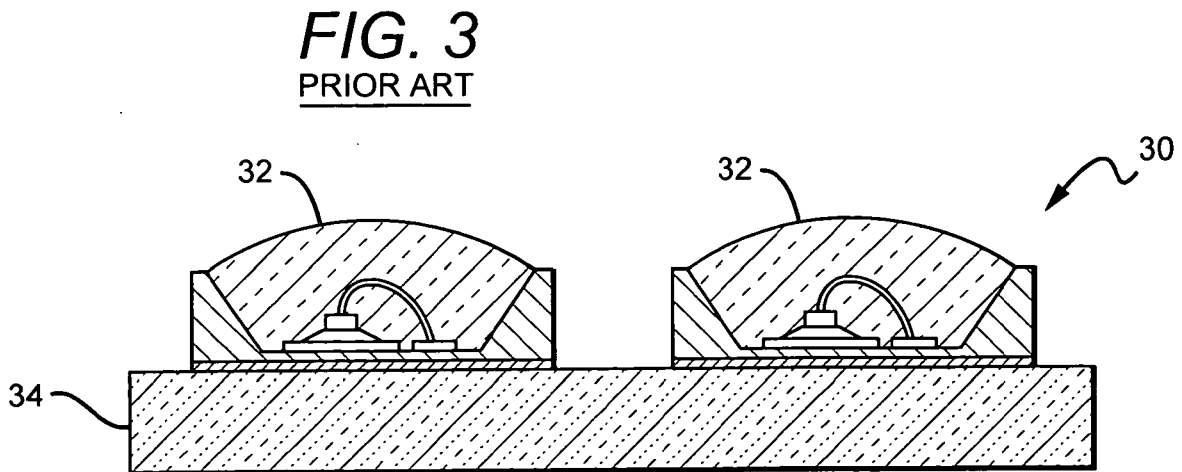

FIG. 3
PRIOR ART

FIG. 4

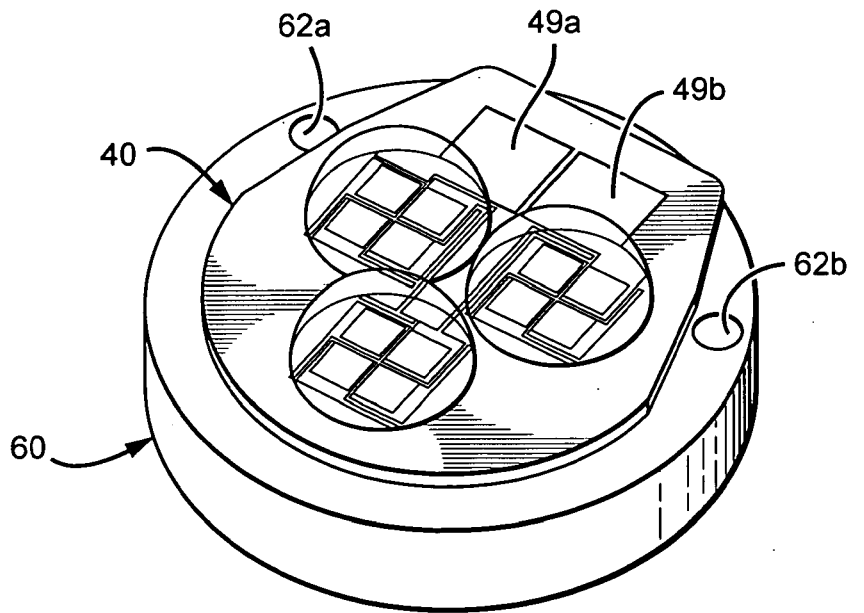
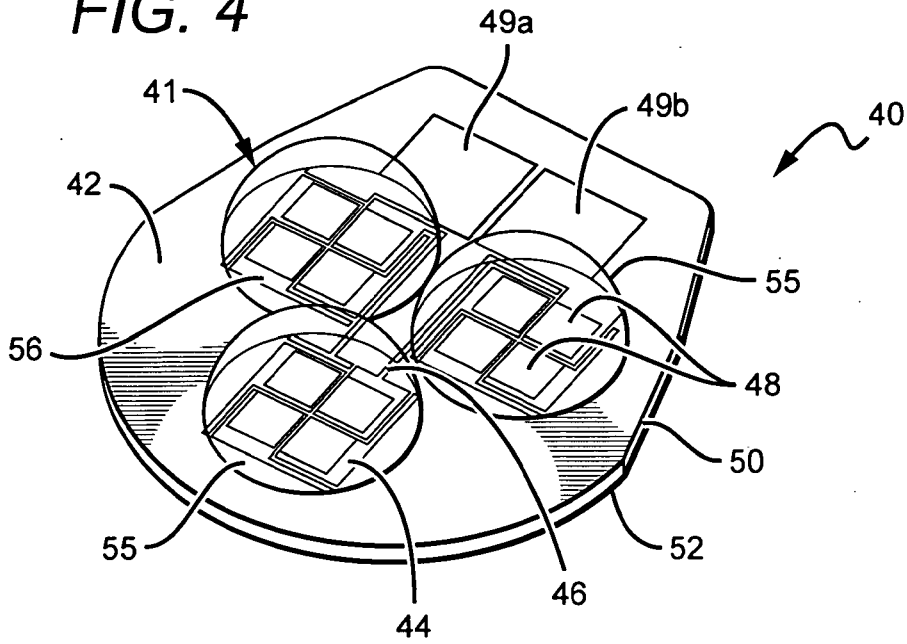

FIG. 5

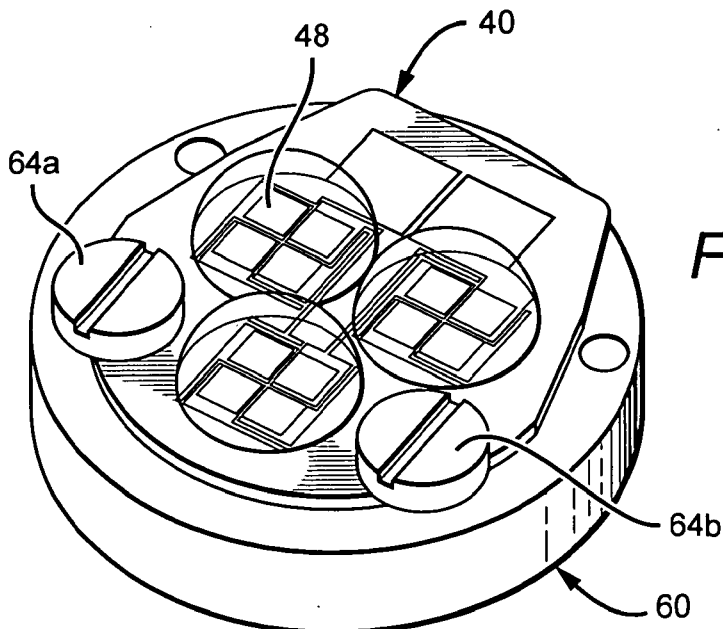
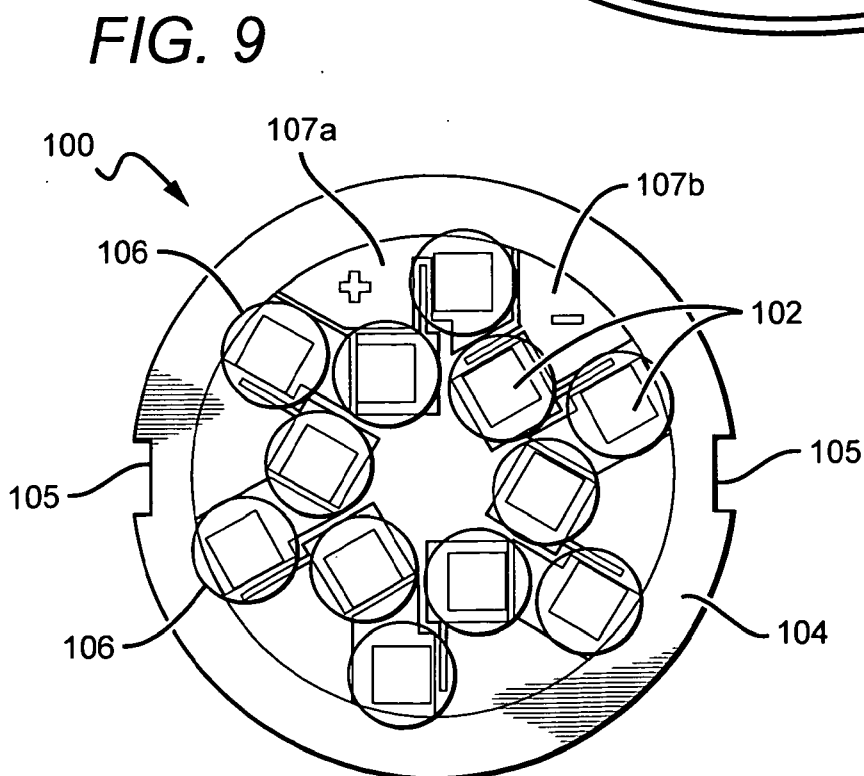
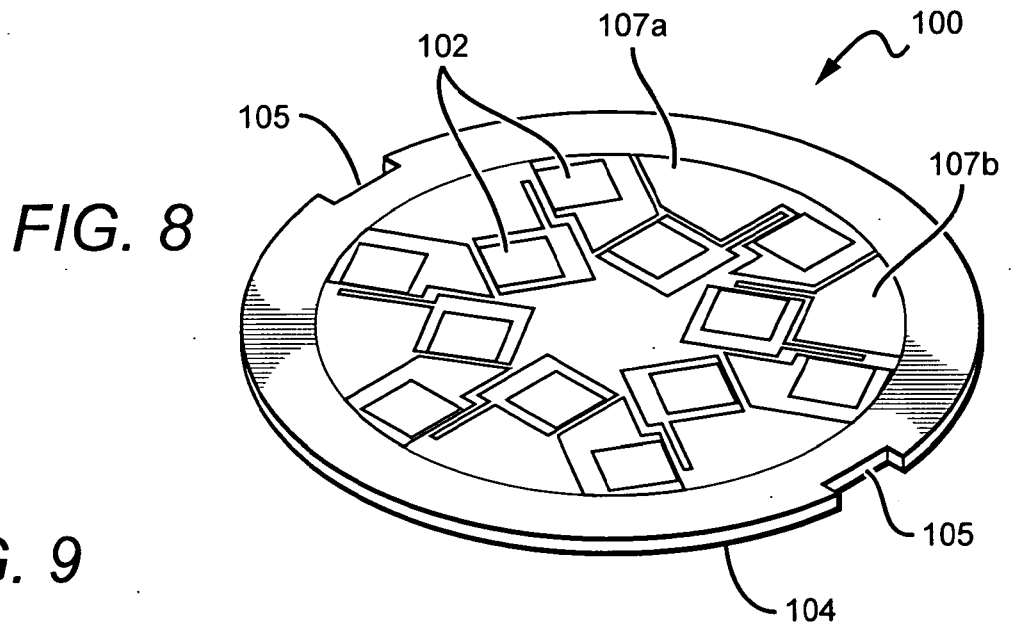
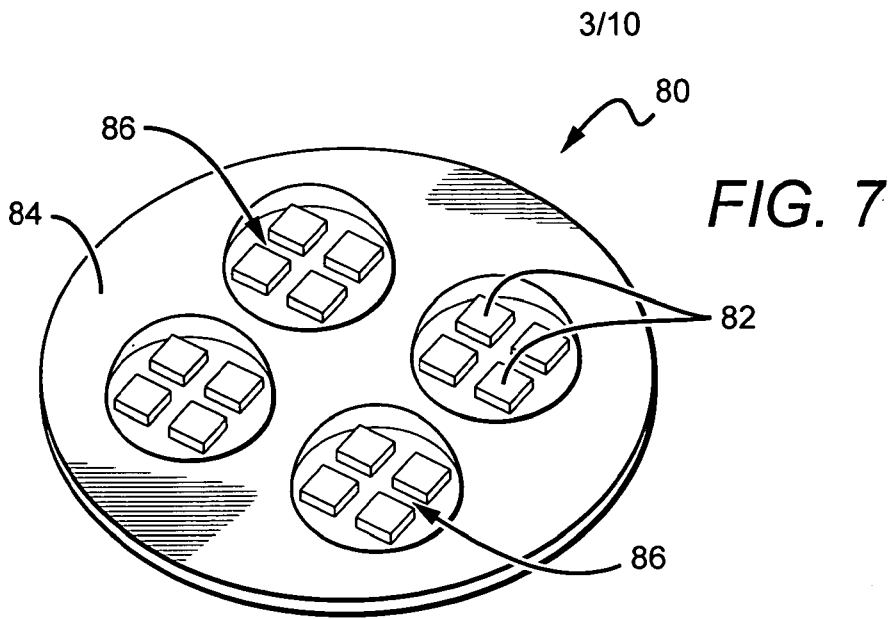

FIG. 6



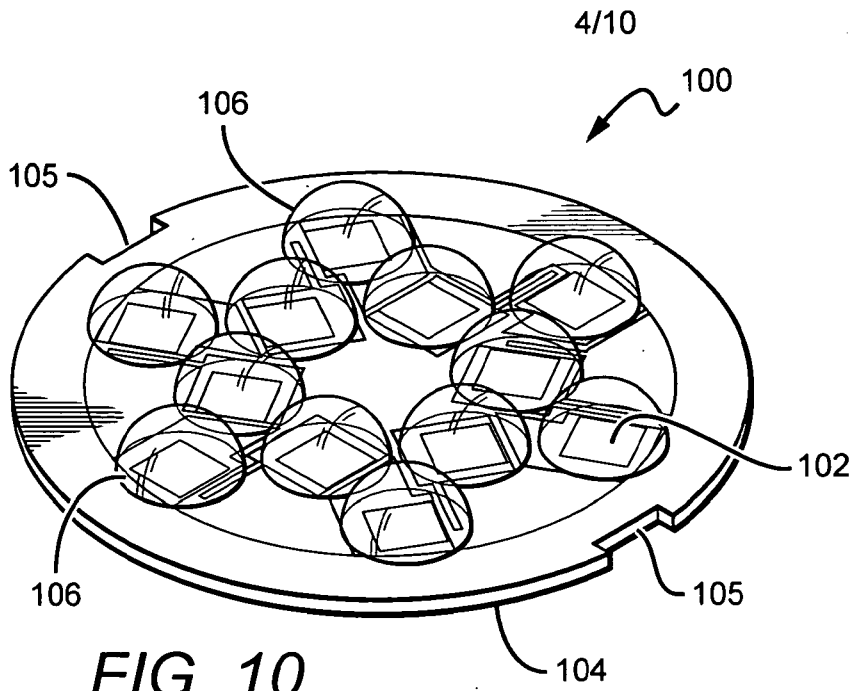

FIG. 10

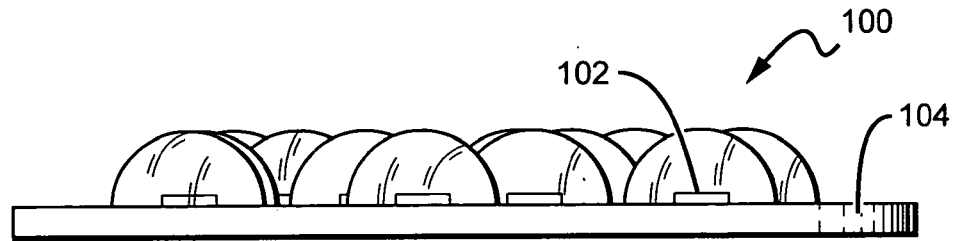

FIG. 11

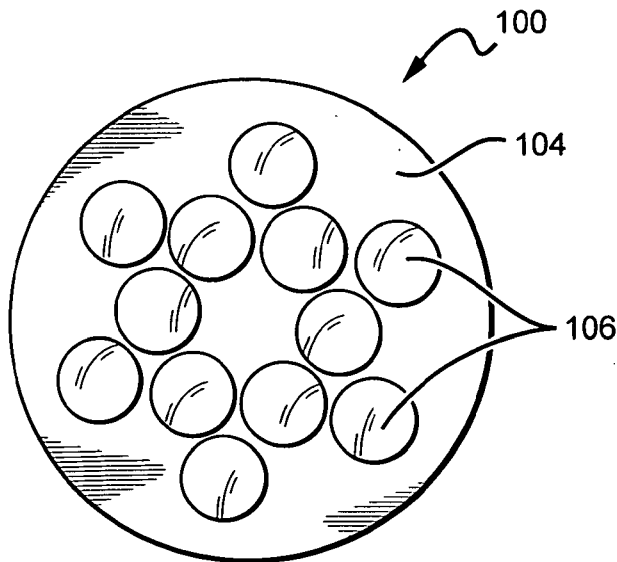

FIG. 12

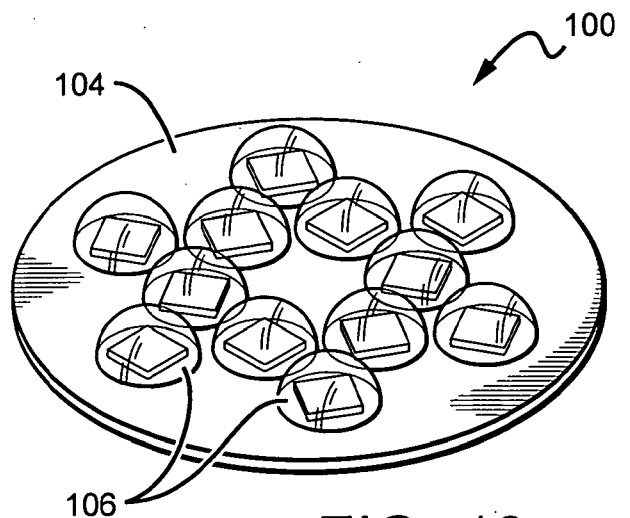

FIG. 13

FIG. 14

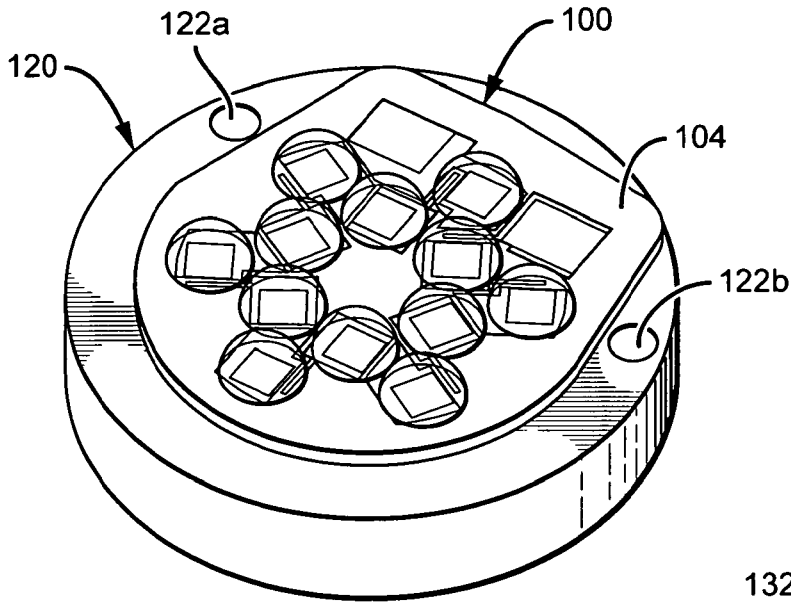

FIG. 15

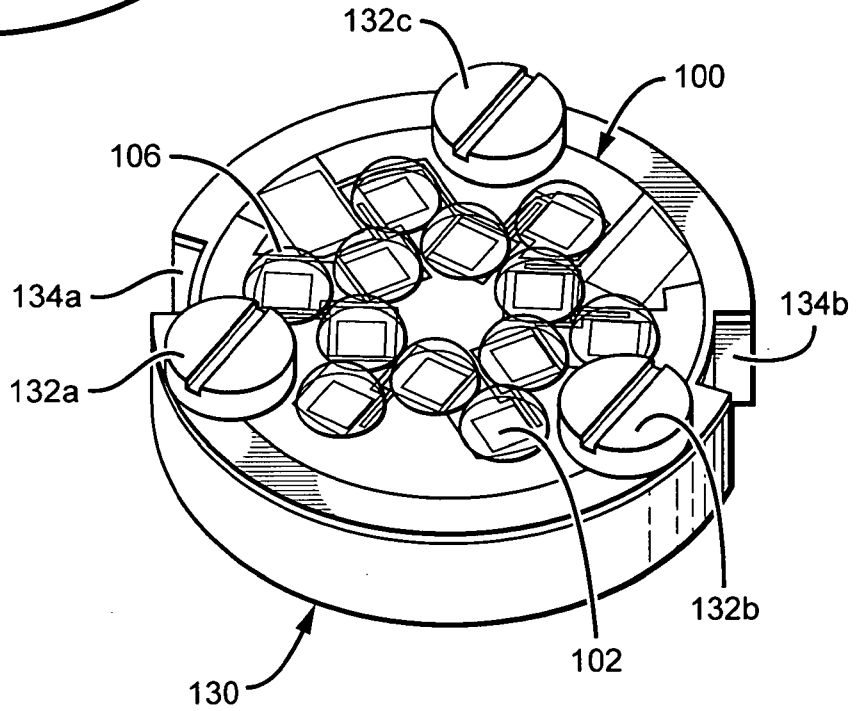

FIG. 16

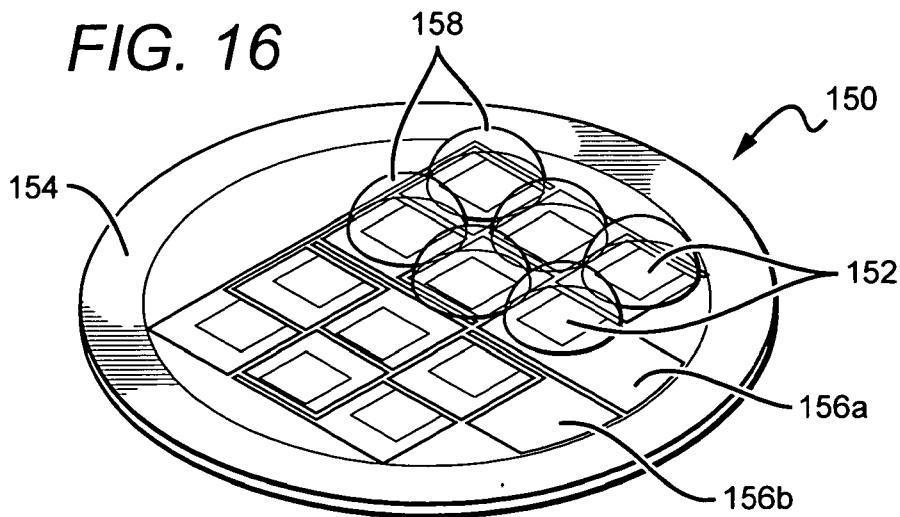

FIG. 17

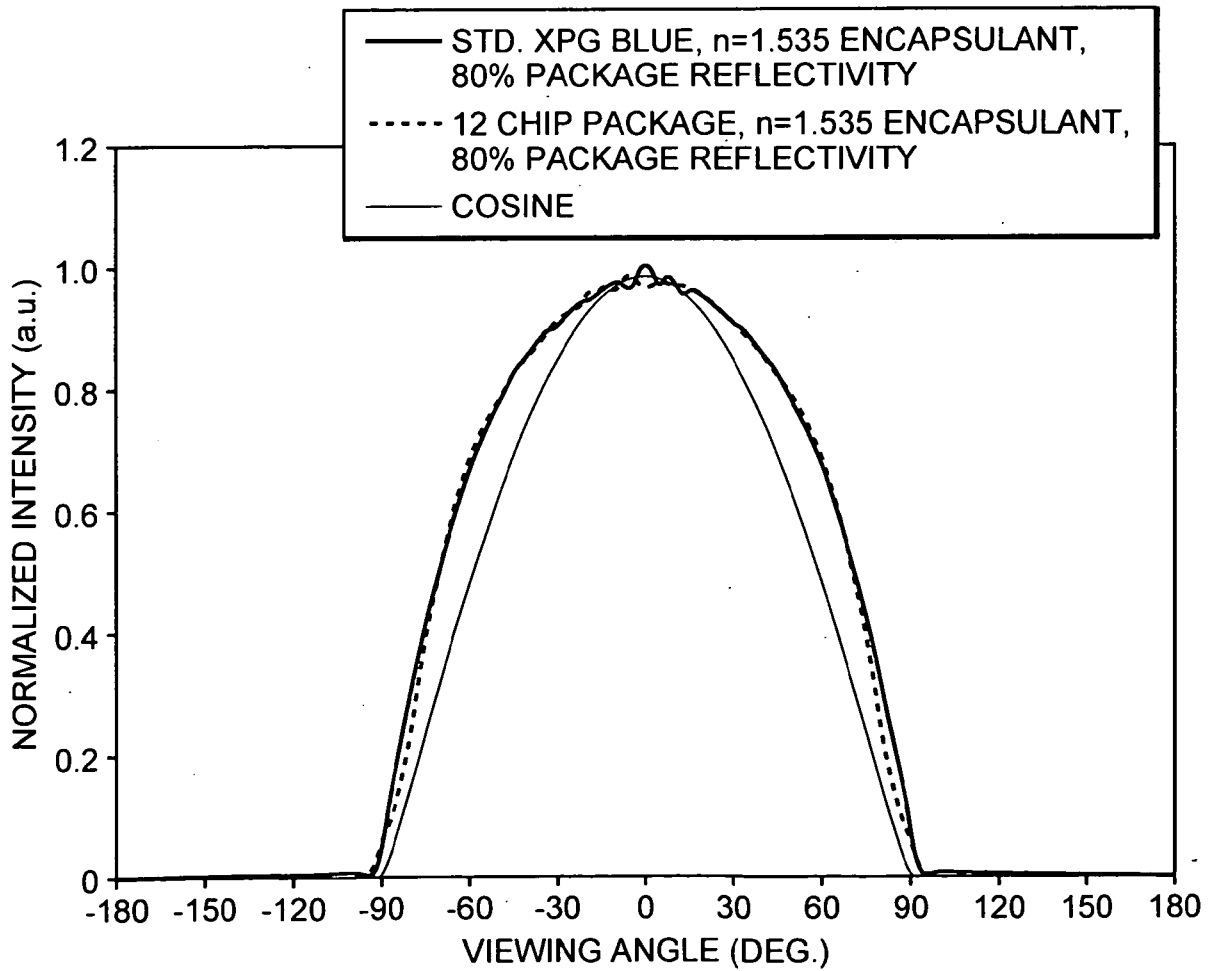
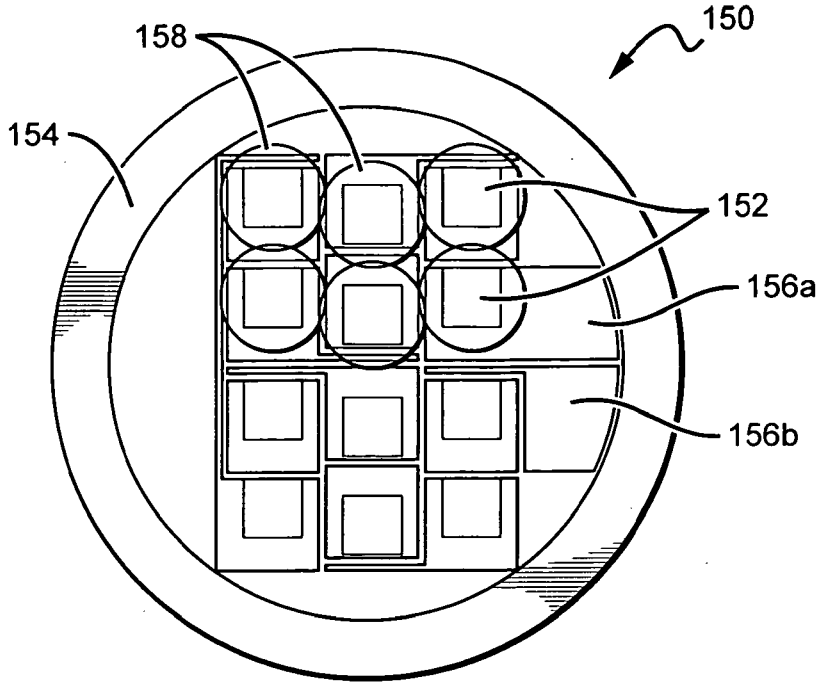

FIG. 18

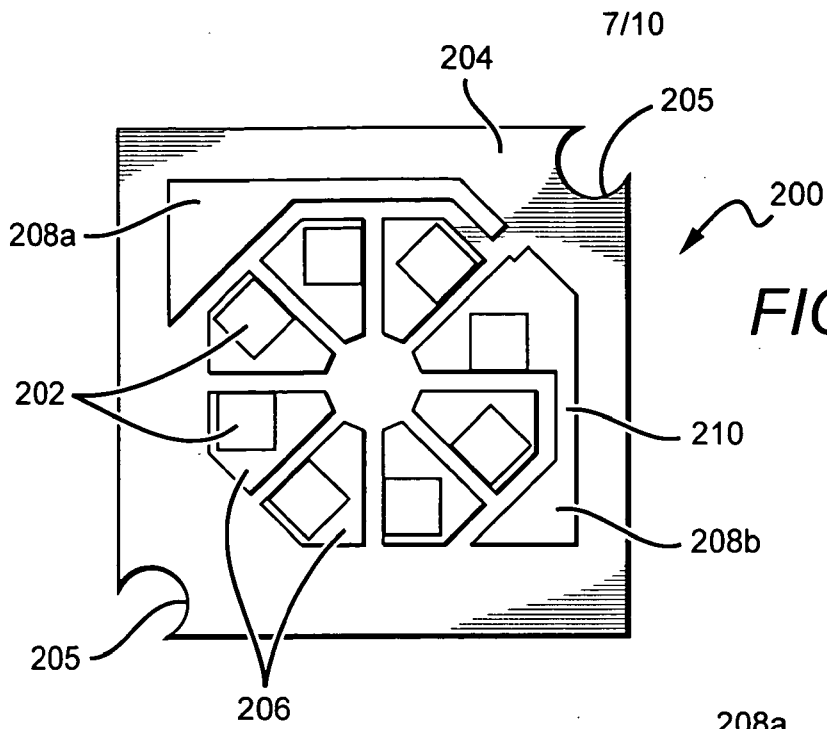

FIG. 19

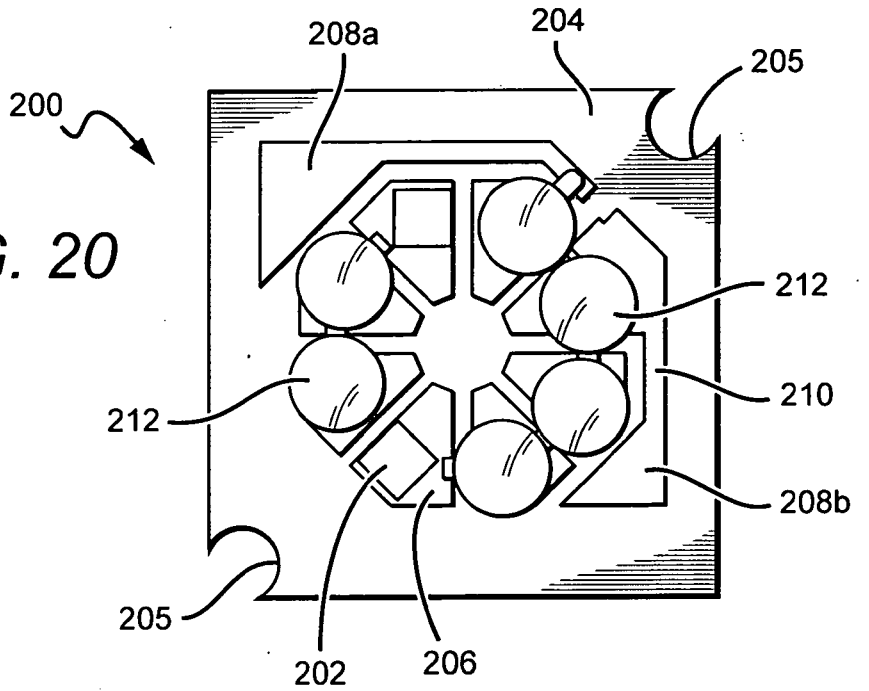

FIG. 20

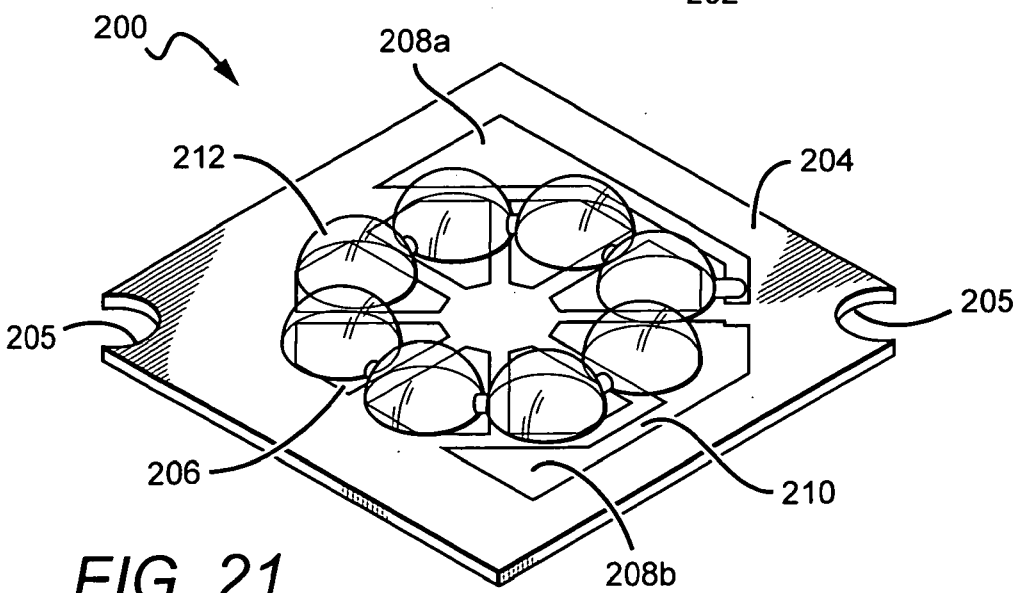

FIG. 21

FIG. 22

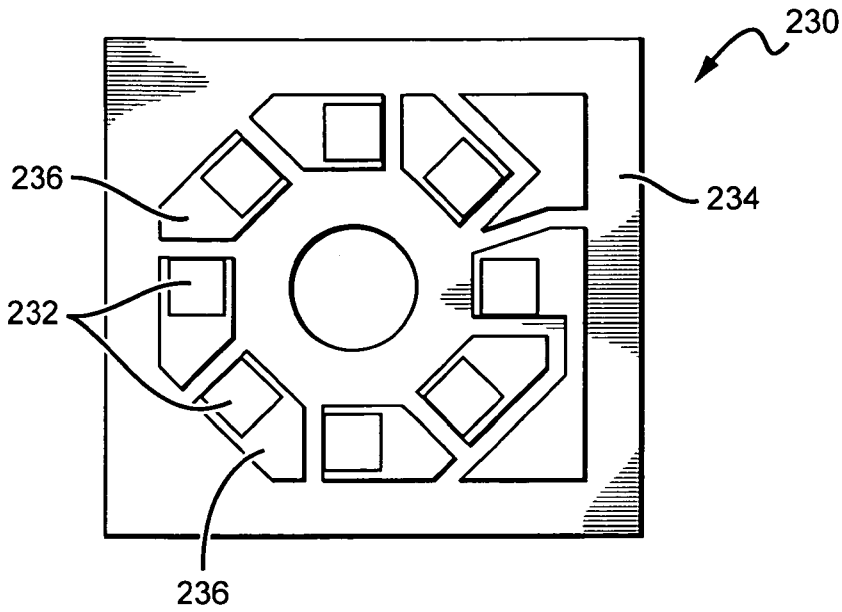

FIG. 23

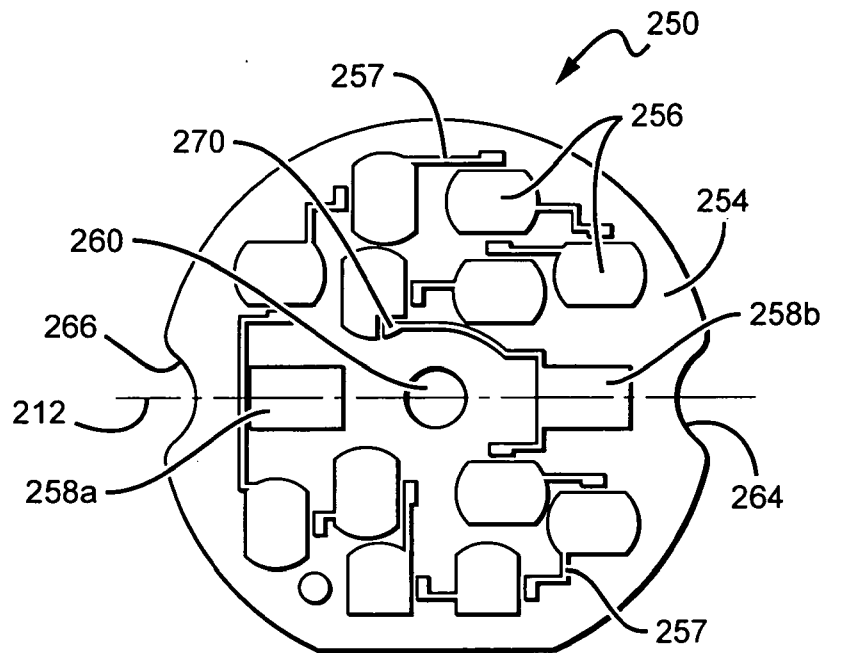

FIG. 24

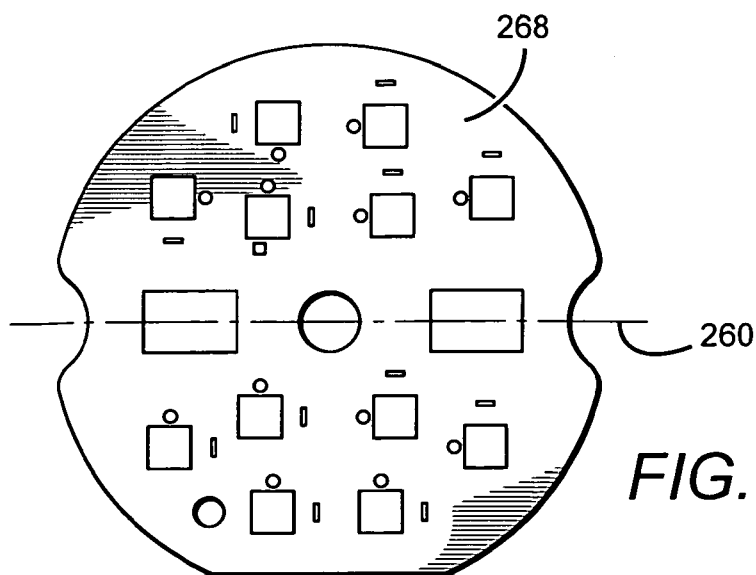

FIG. 25

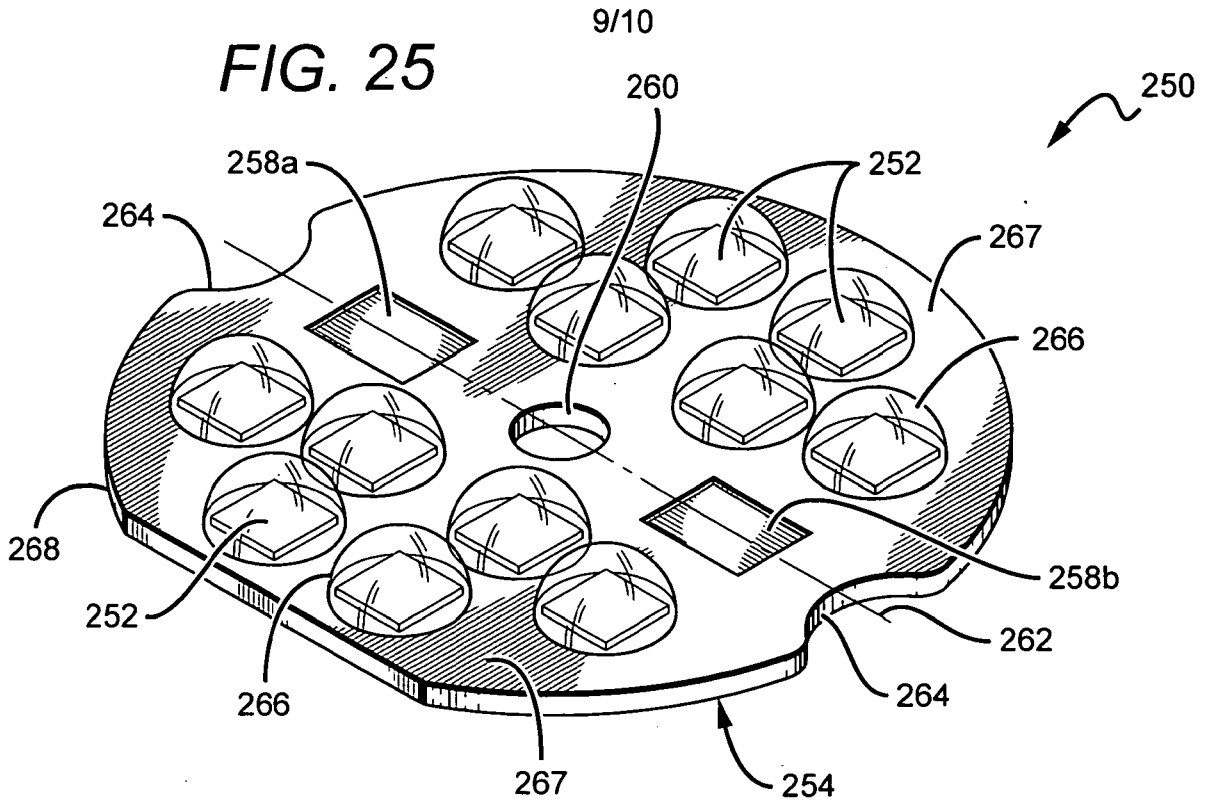

FIG. 26

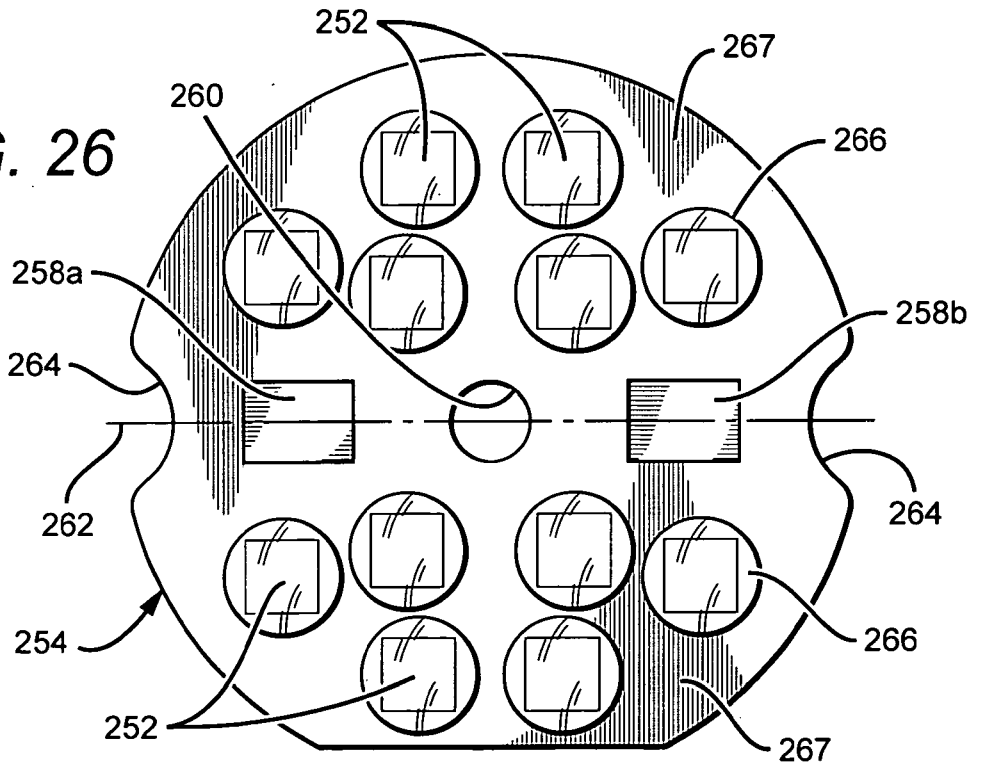

FIG. 27

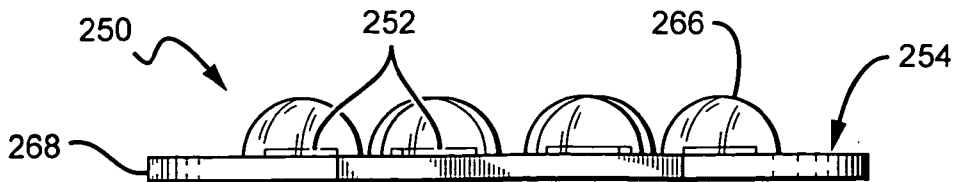

FIG. 28

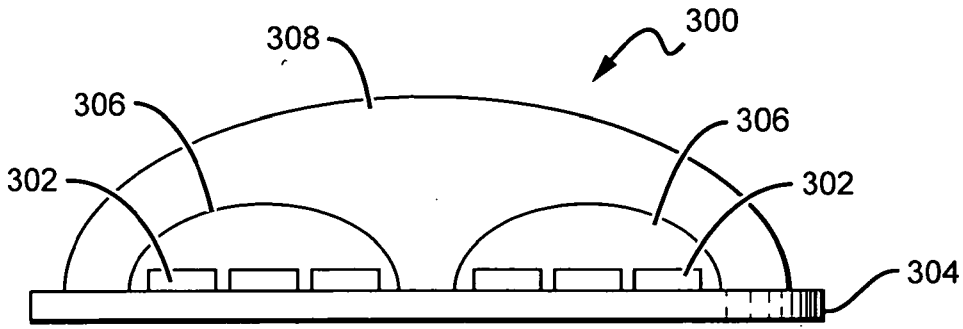
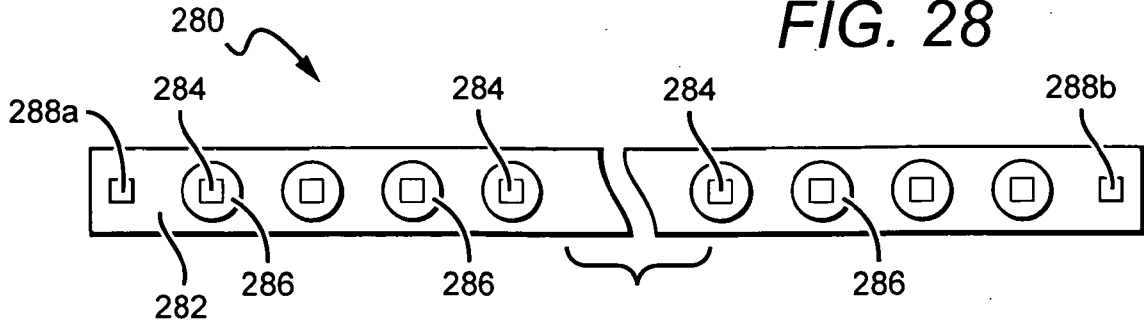

FIG. 29

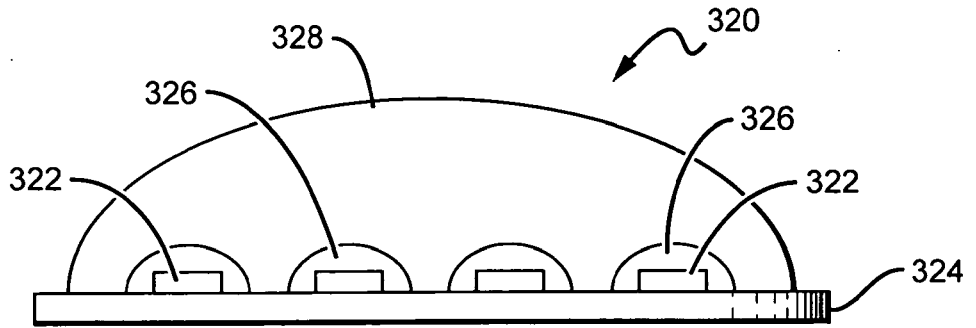

FIG. 30

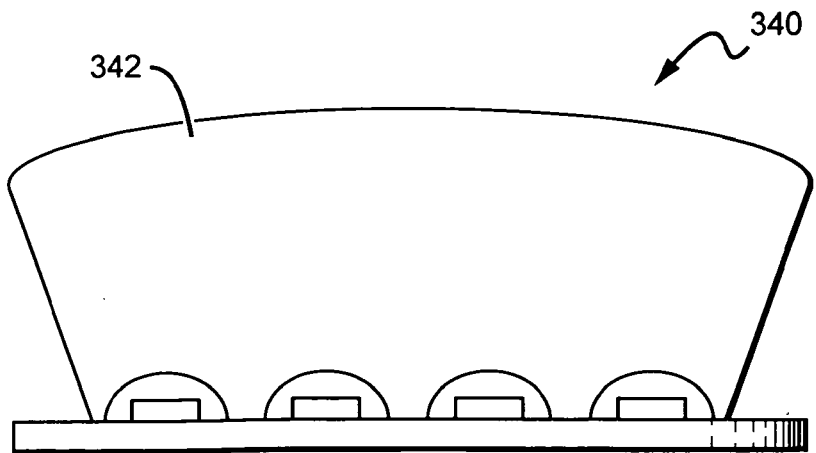

FIG. 31