

No. 751,701.

PATENTED FEB. 9, 1904.

A. R. TIFFANY.
TOOL SUPPORT FOR LATHES.

APPLICATION FILED MAY 9, 1903.

NO MODEL.

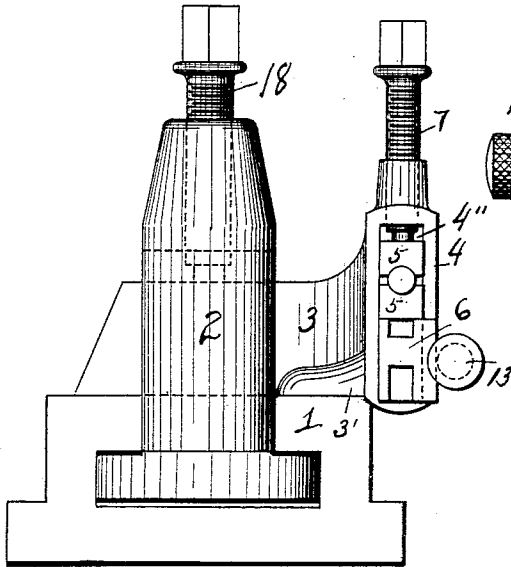

Fig. 1.

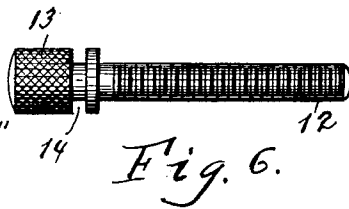

Fig. 6.

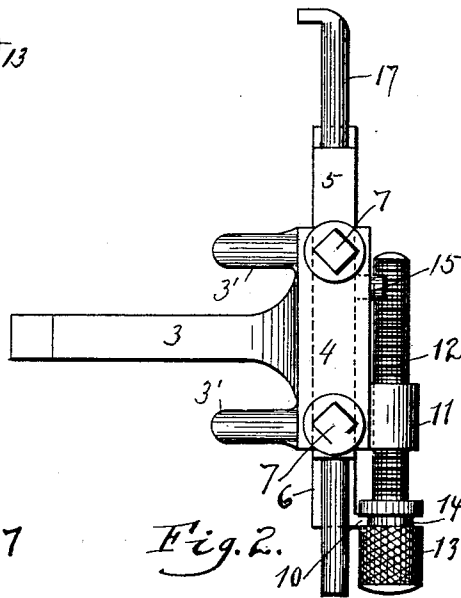

Fig. 2.

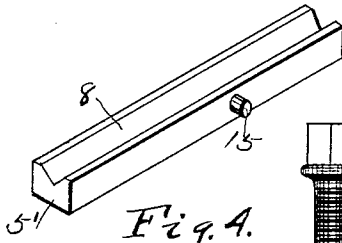

Fig. 4.

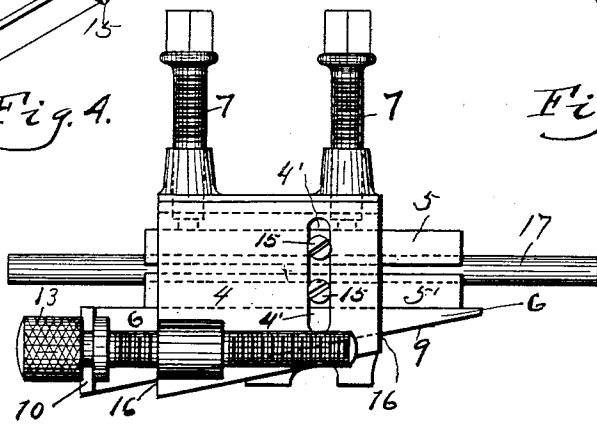

Fig. 3.

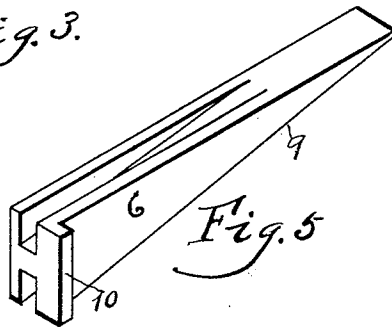

Fig. 5.

WITNESSES:
Matthew Sibley
C. M. Sheebald.

A. R. Tiffany
 INVENTOR

BY *J. M. Carly*
 ATTORNEY

UNITED STATES PATENT OFFICE.

ALBERT R. TIFFANY, OF DAYTON, OHIO.

TOOL-SUPPORT FOR LATHES.

SPECIFICATION forming part of Letters Patent No. 751,701, dated February 9, 1904.

Application filed May 9, 1903. Serial No. 156,382. (No model.)

To all whom it may concern:

Be it known that I, ALBERT R. TIFFANY, a citizen of the United States, residing at Dayton, in the county of Montgomery and State of Ohio, have invented certain new and useful Improvements in Tool-Supports for Lathes; and I do declare the following to be a full, clear, and exact description of the invention, such as will enable others skilled in the art to which it appertains to make and use the same, reference being had to the accompanying drawings, and to the figures of reference marked thereon, which form a part of this specification.

This invention relates to an attachment for lathes; and it consists of an adjustable tool-holder which is adapted to be supported in the ordinary tool-post of a lathe.

The object of my invention is to provide an adjustable tool-holder which is easy of manipulation in adjusting the tool to the proper vertical position relative to the work or material upon which it is to operate.

Preceding a detail description of the invention, reference is made to the accompanying drawings, of which—

Figure 1 is a view of the ordinary slide-rest and tool-post of a lathe, showing my improved adjustable tool-holder in position. Fig. 2 is a top view of my improved tool-holder detached from the tool-post shown in Fig. 1. Fig. 3 is a side elevation of my improved tool-holder detached. Fig. 4 is a perspective view of one of the V-shaped blocks removed from the device. Fig. 5 is a similar view of the adjusting wedge-block. Fig. 6 is a detached view of the adjusting-screw.

In a detail description of my invention similar reference characters indicate corresponding parts.

The slotted slide-rest 1 and the upright tool-post 2 are well-known features of a lathe and are only incorporated for the purpose of showing the manner of applying my improved tool-holder, described as follows: The frame consists of a box 4, which has a horizontal opening 4" extending the length thereof from end to end, which receives parts to be presently described. From the casing or box 4 there projects on one side an arm 3, that enters the vertical slot in the tool-post 2. Against the

upper side of this arm 3 a screw 18 binds, said screw being projected into the top of the tool-post 2, and by means thereof the arm 3 is maintained in rigid position against the upper side of the slide-rest 1. Also projecting from the box or casing 4 are two rest-lugs 3', which rest upon the slide-rest 1 and serve to provide a proper level contact between the arm 3 and the slide-rest 1 to provide a substantial support for the casing or box 4. As before stated, the box or casing 4 has a square opening 4" extending through it. In the upper portion of this opening upper and lower tool-clamping blocks 5 5' are placed, with suitable space to permit of their free vertical movements. These clamping-blocks 5 5' have in their adjacent sides V-shaped grooves 8, which receive the boring or other tool 17, which is designed to operate upon the work. It is desirable to have these grooves V-shaped for the reason that a proper rigid contact is necessary between said blocks and the tool 17.

4' designates a vertical slot in one side of the box or casing 4.

15 designates pins, of which there is one projecting from a side of each of the clamping-blocks 5 5'. The heads of these pins enter the slot 4', and by means thereof the clamping-blocks 5 5' are prevented from falling out of the box or casing 4 endwise; but the said clamping-blocks are permitted to have the necessary vertical adjustments owing to the length of the slot 4' being greater than the combined widths of the clamping-blocks 5 5'. (See Fig. 3.) The lower surface of the opening 4" is tapered, as at 16, Fig. 3, and the portion of said opening below the clamping-blocks 5 5' receives a wedge-shaped adjusting-block 6. The surface of said adjusting-block which is adjacent to the lower clamping-block 5' is straight, while the surface 9 of said wedge-block adjacent to the lower surface 16 of the opening 4" is on a suitable inclination to coincide with the inclination 16, so that the said block 6 may be moved upon said surface 16 to elevate the clamping-blocks 5 5' or permit of their being lowered.

10 designates a flange or projection on one

end of the adjusting wedge-block 6, which enters a groove 14 in an adjusting-screw 12, said adjusting-screw having a screw-threaded engagement with an open lug 11, which projects from the box or casing 4. By turning the screw 12 by means of the finger-piece 13 it will be readily seen that the screw may be moved in its support 11 in either direction, and will thereby impart a corresponding movement to the adjusting wedge-block 6 owing to the engagement of the flange 10 in the groove 14.

7 designates two binding-screws, which operate upon the upper side of the clamping-block 5 when suitable adjustment of the blocks 5 5' have been obtained through the adjusting-screw 12 and the wedge-block 6.

The adjusting-block 6 may be operated to move it on the tapering seat of the casing 4 by other than the adjusting-screw 12. Therefore I do not wish to limit myself to that particular means for adjusting said block.

Having described my invention, I claim—

1. A tool-holder for lathes consisting of a box or casing adapted to be supported upon a lathe, upper and lower clamping-blocks having V-shaped grooves within said casing and adapted to hold between them the tool to be operated, means for preventing endwise dislodgment of said clamping-blocks from said casing, an adjusting-block within said casing below said clamping-blocks, an adjusting-screw supported on said casing and engaging a portion of the adjusting-block, whereby said adjusting-block is given longitudinal movements from said screw to elevate or lower the clamping-blocks, substantially as set forth.

2. In a tool-holder for lathes, the combination with a tool-post of a lathe, of a box or casing having a longitudinal opening therein extending from end to end, the lower terminal of said opening being on an incline, and a side of the box or casing having a vertical slot therein communicating with the longitudinal opening therein, two clamping-blocks arranged in parallel relation in the longitudinal opening of said box or casing, the adjacent sides of said clamping-blocks being provided with V-shaped grooves adapted to receive a tool, a wedge-shaped adjusting-block within said box or casing below the clamping-blocks and upon which one of said clamping-blocks rests, a lateral flange projecting from said adjusting wedge-block, and an adjusting-screw supported on said box or casing parallel with said adjusting wedge-block, the said screw having an annular groove adapted to engage

the flange on the wedge-block to impart longitudinal movements to said wedge-block, substantially as set forth.

3. In a tool-holder for lathes, a box or casing adapted to be supported in a tool-post of a lathe, said box or casing having a longitudinal opening therein, clamping-blocks within the upper portion of said opening, said clamping-blocks adapted to hold between them the tool to be operated, means for preventing said clamping-blocks from moving endwise, an adjusting wedge-block mounted in said casing below the clamping-blocks and adapted to lower or elevate said clamping-blocks and therewith the tool held thereby, binding-screws engaging the upper clamping-block, an adjusting-screw mounted on the lower portion of the box or casing, said adjusting-screw engaging with the wedge-block and imparting longitudinal movements to said wedge-block, substantially as set forth.

4. In a tool-holder for lathes, the combination with the slide-rest of a lathe, of a box or casing adapted to be supported on said slide-rest, clamping-blocks arranged one above the other in said casing, a wedge-shaped adjusting-block having a projecting portion mounted in the lower portion of said casing and supporting the lower clamping-block, an adjusting-screw mounted on said casing parallel with the clamping-blocks, said adjusting-screw having an annular groove near its head adapted to receive said projecting portion of the wedge-block and whereby said wedge-block is actuated to raise or lower the clamping-block, and binding-screws engaging the upper one of said clamping-blocks, substantially as set forth.

5. In a tool-holder for lathes, an open end box or casing having a tapering bottom, clamping-blocks loosely mounted within said casing and adapted to hold the tool to be operated, means for preventing said clamping-blocks from falling out of the casing, a wedge-shaped adjusting-block seated on the tapering bottom of the casing and adapted to elevate or lower the position of the clamping-blocks; and means for actuating said wedge-shaped adjusting-block to change its position, substantially as set forth.

In testimony whereof I affix my signature in presence of two witnesses.

ALBERT R. TIFFANY.

Witnesses:

R. J. McCARTY,
JOHN W. KALBFUS.