

(19) **DANMARK**

(10) **DK/EP 1836896 T3**



(12) **Oversættelse af  
europæisk patentskrift**

Patent- og  
Varemærkestyrelsen

- 
- (51) Int.Cl.: **A 22 C 11/02 (2006.01)** **F 16 K 1/36 (2006.01)**
- (45) Oversættelsen bekendtgjort den: **2016-12-19**
- (80) Dato for Den Europæiske Patentmyndigheds bekendtgørelse om meddelelse af patentet: **2016-09-14**
- (86) Europæisk ansøgning nr.: **07006713.7**
- (86) Europæisk indleveringsdag: **2006-03-09**
- (87) Den europæiske ansøgnings publiceringsdag: **2007-09-26**
- (62) Stamansøgningsnr: **06004867.5**
- (84) Designerede stater: **AT BE BG CH CY CZ DE DK EE ES FI FR GB GR HU IE IS IT LI LT LU LV MC NL PL PT RO SE SI SK TR**
- (73) Patenthaver: **Albert Handtmann Maschinenfabrik GmbH & Co. KG, Hubertus-Liebrecht-Strasse 10-12, 88400 Biberach, Tyskland**
- (72) Opfinder: **Maile, Bernd, Kirchplatz 8, 88422 Oggelshausen, Tyskland**  
**Staudenrausch, Martin, Mettenberger Weg 9, 88400 Biberach, Tyskland**
- (74) Fuldmægtig i Danmark: **Larsen & Birkeholm A/S Skandinavisk Patentbureau, Banegårdspladsen 1, 1570 København V, Danmark**
- (54) Benævnelse: **Indretning og fremgangsmåde til fyldstandsregulering og til reguleret evakuering af pastøse masser**
- (56) Fremdragne publikationer:  
**EP-A- 1 502 509**  
**DE-A1- 4 417 906**  
**GB-A- 1 380 082**  
**US-A- 3 166 786**  
**US-A- 4 427 040**



**Device and method of closed-loop level control and for the controlled  
evacuation of paste masses**

5 The invention relates to a vacuum hopper for sausage production, a vacuum filler comprising a vacuum hopper of this nature as well as a method for the closed-loop level control and for the controlled evacuation of paste masses.

A vacuum filler is already known from document EP 1 502 509 A1. The vacuum filler has an inlet valve. The inlet valve serves to control the filling level.

10 From document US 3,166,786 there is already known a vacuum filler. In order to extract as much as possible air from the pasty mass there is provided a disc having small holes producing small streams in order to extract more air from the mass. The size of the holes and the disc are constant such that the degree of evacuation can't be changed.

15 Normally, during sausage production filling machines are used, the hoppers of which are open at the top. Here, the sausage meat situated in the hopper is transported to the centre by a circumferential feeder curve. In the conveying mechanism located at the outlet of the hopper a negative pressure is produced by a vacuum pump in order to extract air and thus also oxygen from the sausage meat, so that the shelf life of the sausage is extended. On the other hand, a pressure difference  
20  $\Delta p$  to the surface of the hopper charge arises in the conveying mechanism due to the negative pressure such that the paste mass is pressed into the conveying mechanism chamber by the atmospheric air pressure.

25 The evacuation of the sausage meat can only take place to a restricted extent using this method. In order to extract more air and thus oxygen from the sausage meat, closed hoppers are employed, so-called vacuum hoppers, wherein a negative pressure is produced already in the hopper. Through the negative pressure the paste mass to be charged is pressed out of a reservoir by the higher pressure

prevailing there into the closed hopper. Alternatively, the charging of the vacuum hopper can also take place under pressure with an additional pump. During and after the mass has flown into the closed evacuated hopper, air content near to the surface, such as for example air bubbles, are opened up and drawn off from the  
5 paste filling mass, i.e. a certain evacuation of the inflowing mass occurs.

The filling level in the hopper is here normally acquired using a level sensor. Depending on the filling level the valve on the feed tube is opened or closed (two-step control). The purpose of this control is solely the level control of the hopper  
10 content.

However, the known techniques exhibit the disadvantage that the inflow of the mass takes place more or less abruptly and uncontrollably. Also, the degree of evacuation of the inflowing mass is not optimal due to the principle, because the air content in the mass remote from the surface remains.

15 Against this background the object of the invention is to provide a device and a method which with an evacuated hopper for the inflowing mass, enable the degree of evacuation to be influenced or controlled in addition to the closed-loop level control.

According to the invention this object is solved by the features of Claims 1 and 16.

20 In view of the fact that according to the invention the height of the inlet gap on the inlet valve can be controlled by a closed-loop control device, the specific degree of evacuation and thus the remaining amount of air or remaining oxygen in the paste mass can be influenced and controlled. Thus, according to the invention the thinnest mass cross-section possible can be achieved in the inflow region.  
25 Therefore, all the enclosed air content is near to the surface and can thus be easily opened up and drawn off. The degree of evacuation depends amongst other effects on the mass cross-section and thus on the inlet gap height.

Thus according to the invention the inlet gap on the inlet valve of the vacuum hopper can be controlled for the closed-loop level control and for the controlled evacuation of the paste mass. The inflow of the paste mass no longer occurs abruptly or uncontrolled, but rather controlled and can, for example, be adapted to the filling capacity of the conveying mechanism, to the product properties, such as for example to the air content of the paste mass before inflow into the vacuum hopper, wherein the closed-loop control of the valve no longer occurs via a two-step control, but rather via a multi-step control or proportional control. The air content of the end product can thus be specifically influenced.

Preferably the invention comprises a closed-loop control device for the control of the gap height in dependence of the compressibility or of the air content of the paste mass before the inlet valve and / or after the outlet and / or between the inlet valve and outlet (e.g. in the vacuum hopper) and of level parameters. This means that by changing the air content in the paste mass also the compressibility is changed and the height of the inlet gap is changed in dependence of this quantity in order, for example, to achieve a certain air content. If, for example, a large amount of air is enclosed in the paste mass, then the gap must be selected as small as possible so that the enclosed air bubbles can be easily opened up. The control of the gap  $S$  occurs however also in dependence of level parameters. The level parameters include, for example, the filling capacity of the paste mass through the inlet into the vacuum hopper and / or the filling level in the hopper and / or the conveying capacity of a conveying mechanism which is arranged at the outlet of the vacuum hopper.

A control device of this nature for controlling the gap height controls the gap height, for example, in dependence of at least one parameter from the following group: compressibility or air content of the paste mass before the inlet valve, compressibility or air content of the paste mass after the outlet (e.g. on the outlet of a following conveying mechanism) or in the vacuum hopper, filling capacity of the paste mass in the vacuum hopper, amounts of charges for the mass, pressure

difference before and after the inlet valve, conveying capacity of a conveying mechanism which is arranged on the outlet of the vacuum hopper, as well as the filling level of the paste mass in the vacuum hopper, temperature of the paste mass, viscosity of the paste mass.

5 According to the invention the inlet gap has, for example, a circular or elliptical cross-section. Also other closed cross-sectional shapes are conceivable.

According to the invention the valve on the inlet comprises a valve face and a baffle situated opposite, wherein the distance between the face and baffle gives the gap height. Thus, the inlet valve according to the invention can be realised in an  
10 economical and simple manner.

According to the invention the inlet valve comprises a drive for the baffle for setting the gap height. This drive facilitates an exact setting of the corresponding baffle position or gap height. An embodiment with a fixed baffle and a valve face which is adjustable using a drive is also conceivable.

15 According to a preferred embodiment, the diameter of the baffle is greater than the diameter of the valve face or valve opening. The baffle is thus preferably formed such that the paste mass passes downwards or diagonally downwards, i.e. in the direction of the outlet of the vacuum hopper. Through the diversion of the filling mass downwards, especially with lesser viscous filling masses, the filling level is  
20 better controlled, because the sausage meat does not splash so much on the lid and the hopper wall on entering the hopper.

A baffle of this nature is, for example, formed such that it includes a recess on the side facing the valve face, which comprises a section sloping or diagonally sloping downwards from the central axis of the inlet valve at least in the outer region of  
25 the inlet gap.

At this section the paste mass can then be passed in the direction of the outlet.

A recess of this nature can, for example, exhibit essentially a concave shape or can, for example, run in a ring shape about the central axis of the valve.

5 Preferably, the inlet in the upper section of the vacuum hopper is formed in the shape of a feed tube, the open end of which protrudes into the hopper and faces upwards, wherein the baffle is situated opposite the open end.

10 Preferably the vacuum hopper comprises a device for determining the air content or for determining the compressibility before the inlet valve and / or after the outlet of the hopper, e.g. in the conveying mechanism. If a device of this nature is provided for determining the air content or for determining the compressibility, the measured values can be passed to the closed-loop control device, wherein then, for example, the control of the inlet gap can take place using the measured values. Furthermore, the vacuum hopper can comprise a level sensor. The vacuum hopper can furthermore also comprise a pressure sensor before and / or after the inlet valve.  
15 Additional pressure sensors can be arranged before, in and after the conveying mechanism.

20 A vacuum filler according to the invention also comprises a conveying mechanism, which ejects the paste mass from the outlet of the vacuum hopper and pushes it into a filling tube in order to fill sausages with the paste mass, and furthermore a vacuum filler of this nature comprises a vacuum pump to produce a negative pressure of various levels in the vacuum hopper and, where applicable, also in the conveying mechanism.

25 With the method according to the invention a gap control is executed, wherein the gap height of the inlet gap is controlled such that it is as large as necessary for the level control, but is also as small as is required for the control of the degree of evacuation.

According to the invention the geometry of the valve opening is preferably such that the opening gap, i.e. the inlet gap, is as long as possible, i.e. that the feed tube exhibits a diameter as large as possible so that sufficient mass can be fed, although the height of the gap S is to be maintained as small as possible.

5 The inlet valve for controlling the entry of paste mass in a vacuum hopper comprises a baffle situated opposite a valve face, wherein the baffle is formed such that it diverts the paste mass in a direction opposite or diagonal to the entry direction. This form of baffle leads to a deviation of the filling mass, for example, downwards, wherein on one hand especially with lesser viscous filling masses, the  
10 filling level can be better controlled, because the sausage meat does not splash so much on the lid and the hopper wall on entering the hopper.

In particular the paste mass is guided at an angle of approximately  $100^\circ$  to  $180^\circ$  with respect to the entry direction or with respect to the central axis of the inlet  
15 valve.

According to a preferred embodiment the baffle comprises on a side facing the valve face a recess, which at least in the outer region of the inlet gap comprises a section sloping diagonally downwards from the central axis of the inlet valve.

20 According to a preferred embodiment, the diameter of the baffle is greater than the diameter of the valve face.

The recess can exhibit essentially a concave shape or however a ring shape about the central axis of the valve.

The invention is explained in more detail in the following with reference to the following figures.

25 Fig. 1 shows a schematic section through a vacuum filler according to the invention.

Fig. 2 shows a plan view of a baffle of an inlet valve according to the invention.

Fig. 3 shows in a schematic manner a cross-section of another embodiment of a baffle of the inlet valve according to the invention.

Fig. 4 shows the relationship between the gap height and degree of evacuation.

5 Fig. 5 shows a section through a vane pump, as it can be used for the conveying mechanism for the invention.

Fig. 6 shows schematically a block diagram of a closed-loop control circuit according to the invention.

10 Fig. 1 shows schematically a vacuum filler 100 according to this invention. The vacuum filler 100 comprises a vacuum hopper 1, consisting of a hopper 33 and a lid 2. The hopper 33 and the lid 2 are connected together vacuum-tight via a seal 34, e.g. here a sealing ring. The vacuum hopper 1 comprises an inlet 7 for feeding a paste mass from a reservoir which is not illustrated via the feed tube 8. The hopper 1 also  
15 comprises at the lower end, i.e. at the end opposite the lid 2, an outlet 13 for the paste mass. The paste mass situated in the hopper is here conveyed to the centre by a circumferential feeder curve 10. The feeder curve 10 here comprises a scraper 11. The feeder curve is in a known manner supported for rotation about the central axis D in the bearing 12 and is rotated in a known manner about the axis D with  
20 the aid of a drive which is not illustrated. The scraper 11 here lies adjacent to the interior wall of the hopper 1.

At the outlet 13 a conveying mechanism is arranged which conveys the paste mass from the vacuum hopper 1 into a filling tube 15. Then in the known manner, the paste mass, such as for example the sausage meat, is pushed via the filling tube 15 into  
25 the sausage casings provided.

In the closed vacuum hopper 1 a negative pressure is produced using a vacuum pump 23, which is only shown schematically here. This occurs, for example, via a separate vacuum connection 60. Thus, air and oxygen can be extracted from the sausage meat, wherein the shelf-life of the finished product is extended. The air content is also decisive for the cut appearance and biting texture of the finished product. The negative pressure in the vacuum hopper 1 also has the advantage that the paste mass to be filled from the reservoir is pressed or pulled into the closed vacuum hopper 1 by the normal pressure prevailing in the reservoir. Alternatively, the charging of the vacuum hopper can also take place supported by an additional pump or under pressure.

In the conveying mechanism 14 a negative pressure can also be produced using a vacuum pump 23 to additionally extract air and thus oxygen from the paste mass, i.e. from the sausage meat. The absolute pressure in the conveying mechanism is lower or equal to the pressure in the vacuum hopper so that the paste mass is pressed out of the vacuum hopper into the conveying mechanism chamber by the negative pressure in the conveying mechanism 14. Additional mechanical support for the transfer of the paste mass into the conveying mechanism is conceivable, for example, using a screw conveyor.

An example of a conveying mechanism 14 of this nature is illustrated in Fig. 5. Fig. 5 shows a generally known vane pump as is described in more detail in EP 1040758 B1 or in DE 4227621 A1. As can be seen from Fig. 5, the vane pump consists of a pump housing 40 and a rotor arranged eccentrically in it, which can be rotated, with a pump shaft 41. In the rotor, vanes 43, supported for radial movement, are arranged, which form conveying cells 46 with the wall 42 of the pump housing 40, the bottom 45 and the lid (not illustrated) of the housing and the outer surface of the rotor 41, mutually providing sealing, wherein the pump housing 40 comprises an inlet 50 and outlet 51 for sausage meat, between which a compression sector 52 and a dosing sector 53 can be realised. The inlet 50 is connected to the outlet 13 of the vacuum hopper 1. In the compression sector 52

the interior wall 42, for example in this embodiment, changes its distance to the pump shaft 41 such that the length of the vanes 43 shortens in the direction A of the compression space during the rotation of the rotor about the pump shaft 41, because the vanes are pushed in the direction towards the shaft 41 on the compression space side. If the rotor therefore moves in the direction of rotation A about the pump shaft 41, the volume of the chamber 8a is reduced in the compression sector 52. In the dosing sector 53 the chamber volume remains constant during the rotation of the rotor about the shaft 41 so that a defined dosing volume is produced. In the outlet sector 59 the respective vane cell is connected to a vane cell outlet 51 through which the paste mass, for example, is pushed into the filling tube 15.

As already mentioned, in addition to the level control, the invention also facilitates the influence or control of the degree of evacuation of the mass flowing into the vacuum hopper 1.

The inlet valve 3 on the inlet 7 is provided for this. Here, the valve 3 comprises the valve face 9 which is located at the end of the feed tube 8. The inlet 7 is here provided in the upper section, i.e. in the upper third of the vacuum hopper 1. The feed tube 8 protrudes into the vacuum hopper, wherein in this embodiment the open end of the feed tube 8 faces upwards. Furthermore, an appropriate seal, sealing ring, etc. can be arranged at the upper end of the feed tube 8. The inlet valve 3 also comprises the baffle 5, which is situated opposite the valve face 9 of the feed tube 8. The baffle 5 is joined via the bar 17 to the drive 4 which can move the baffle 5 in the arrow direction F upwards and downwards along the central axis M of the inlet valve 3. The central axis M of the valve 3 runs essentially parallel to the central axis D of the vacuum hopper 1. The drive 4 comprises a motor, for example a stepper motor, which is controlled by a controller or closed-loop control device 22 and which sets the position of the baffle 5. With the valve open an inlet gap S is therefore produced between the valve face 9 on the upper end of the filling tube 8 and the oppositely located lower edge of the baffle 5. The sausage meat or paste

mass fed via the filling tube 8 then enters the vacuum hopper 1 via the circumferential inlet gap S.

5 The valve geometry is preferably designed such that the inlet gap S exhibits the longest possible length, i.e. such that the filling tube exhibits the largest possible diameter or largest possible circumference. This facilitates the inlet gap S having a relatively low height h. Preferably the inlet gap S exhibits a circular or oval or elliptical cross-sectional geometry, but other cross-sectional geometries are also conceivable. Thus a relatively thin mass cross-section is produced in the inflow section. This means that all the enclosed air content is near to the surface and can  
10 thus be easily opened up and drawn off.

Thus, the extent of evacuation can be influenced via the height h of the inlet gap S. As can be seen from Fig. 1, the baffle 5 exhibits a larger diameter than the feed tube 8 in the region of the valve face 9, so that the end sections of the baffle 5 protrude over the valve face 9. Preferably the baffle 5 is formed such that the  
15 entering sausage meat is diverted downwards, i.e. to the outlet 13 of the vacuum hopper 1. Through the special shape of the baffle 5, especially with less viscous filling masses, the filling level is better controlled, because the sausage meat does not splash so much on the lid and the hopper wall on entering the hopper. As is apparent, for example, from Figs. 1 and 2, the baffle 5 also has, on the side facing  
20 the valve face, a recess 6 which at least in the outer region of the inlet gap S exhibits a section A which slopes diagonally outwards and downwards from the central axis M. This sloping section diverts the mass downwards. The sloping section A should be provided, at least in the region which borders the inlet gap from outside (between the underside of the baffle and the valve face 9), but must  
25 not however, as can be seen from Fig. 1, extend completely to the outer edge of the baffle 5.

Fig. 2 shows a plan view of the baffle 5 illustrated in Fig. 1, wherein the recess 6 can be clearly seen which here extends in a ring shape about the central axis M

of the valve.

The shape is however not restricted to the shape of the recess 6 illustrated in Fig. 1. For example as illustrated in Fig. 3, also a concave shaped recess 6 can be formed in the baffle 5 which essentially runs rotationally symmetrically to the central axis M. As can, for example, be clearly seen in Fig. 3, the recess 6 comprises a section A which here slopes at about  $130^\circ$  with respect to the inlet direction E, i.e. to the central axis M, thus diverting the inflowing mass downwards. The section A should be sloped at an angle of approximately  $100 - 180^\circ$  with respect to the central axis M or to the inlet direction E in order to realise an appropriate diversion.

According to the invention the height h of the inlet gap S is controlled such that depending on various parameters the inlet gap S is maintained only so large as necessary for the level control and at the same time so small as possible for the closed-loop control of the evacuation. This is resolved by a minimum gap control. At least one of the following group can be considered as parameter for the control: compressibility or air content of the paste mass before the inlet valve, compressibility or air content of the paste mass after the outlet 13, e.g. on the outlet of the conveying mechanism 14, filling capacity of the paste mass from the reservoir into the vacuum hopper 1, amounts of charges of paste mass, pressure difference before and after the inlet valve 3, filling level, viscosity of the paste mass, temperature of the mass, etc.

For the measurement of the pressure difference before and after the inlet valve 3 appropriate pressure sensors 18 can be provided before the inlet valve 3 or 19 in the vacuum hopper 1. To determine the filling level in the vacuum hopper an appropriate level sensor 21 can be provided in the vacuum hopper 1. An ultrasonic sensor, mechanical level transmitter or a capacitive or optical sensor, for example, can be used as the level sensor which either gives the exact filling level or whether the filling level is in the permissible range. To determine the air content which is almost proportional to the compressibility of the paste mass, for example, a device

16 for the measurement of the compressibility can be provided in the conveying mechanism 14. A device for the measurement of the compressibility 62, 61 can also be provided before the inlet valve 3 or in the hopper (1). In Fig. 5, 16 represents a device for the measurement of the compressibility. The function of a compressibility sensor is, for example, explained in more detail in EP 1040758 B1. As already mentioned, the volume is changed in the chambers 46 for the compaction of the paste mass. The device 16 thus comprises a pressure sensor, which acquires the change of pressure in the volume-modifying chamber, wherein also the exact change of volume is acquired from which the compressibility can be calculated. Of course, other known devices for the measurement of the compressibility can also be used.

The previously quoted measurement devices, such as the devices for the measurement of the compressibility 16, the pressure sensors 18, 19 and the level sensor 21 can be connected to the closed-loop control device 22 which then in turn controls the setting of the inlet gap S.

The filling capacity (i.e. the filled quantity over time) of the paste mass from the reservoir into the vacuum hopper 1 can, for example, be determined from the following parameters and can also be passed to the control device 22. Height h of the opening gap S, time duration  $\Delta t$  ( $\Delta t = t_1 - t_2$ ), filling level at the time  $t_1$ , filling level at the time  $t_2$ .

As can be seen from the above description, the gap height h of the inlet valve 3 can be controlled depending on various parameters such that both the filling level and also the evacuation of the paste mass can be closed-loop controlled. The closed-loop control here occurs using a minimum gap control, wherein the inlet gap S is maintained only so high as required for the level control and at the same time as small as possible for the control of the evacuation.

Fig. 4 shows schematically the relationship between the degree of evacuation and

the gap height  $h$ . The degree of evacuation also depends on the conveying capacity and thus on the conveying speed  $V_1$  ;  $V_2$  of the mass into the hopper. Normally the degree of evacuation with a slow speed  $V_2$  is higher than for a higher speed  $V_1$ . The degree of evacuation also depends on the negative pressure in the vacuum hopper and under some circumstances on the quality of the paste mass, i.e. on the interstratification in the paste mass.

If therefore the gap height  $h$  of the inlet gap  $S$  is controlled in dependence of the air content, that is in dependence of the compressibility of the paste mass (e.g. before the inlet valve 3 and / or after the outlet 13) and furthermore also in dependence of level parameters such as for example the filling capacity of the paste mass in the vacuum hopper 1 and / or the filling level in the vacuum hopper 1, this can occur using a closed-loop control circuit, wherein the controlled variables are for example the air content of the paste mass and the filling level and the final control element is the inlet valve 3. Thus a certain air content, for example 0.5 to 10%, can be set. The inlet gap  $S$  is however also controlled in terms of a minimum gap closed-loop control such that the filling level lies in a certain target filling level range.

The closed-loop control of the inlet gap  $S$  is explained in more detail in conjunction with Fig. 6, which illustrates a block diagram of an embodiment of a closed-loop control circuit according to the invention.

With the control circuit the controlled variables are the filling level and degree of evacuation, i.e. the air content or compressibility of the paste mass, and the final control element is the inlet valve. The controlled system is the evacuation of the sausage meat or the filling of the hopper. Measuring elements for the closed-loop control are the compressibility sensor and the level sensor. In this specific example the compressibility is measured in the outlet of the conveying mechanism 14 for the control. The closed-loop control device, i.e. the controller, compares the actual and set-point values of the respective controlled variables and sets the inlet gap

- height  $h$  in dependence of the actual / set-point comparison in order to set a certain air content per unit volume in the paste mass and to also maintain the correct filling level. In addition further parameters can influence the control, such as for example the pressure before the inlet valve or the pressure after the inlet valve, the compressibility of the mass before the inlet valve, the compressibility of the mass in the hopper, the viscosity of the mass, temperature of the mass, amounts of charges, etc. The previously mentioned parameters can either be determined as previously described using the appropriate measurement devices, wherein their values are then passed to the controller or however entered.
- 10 The control or closed-loop control device 22 is for this connected to an input device with which, for example, the various set-point values for the air content or compressibility, filling capacity, filling level, pressure in the vacuum hopper 1 and the pressure before the inlet valve 3, the pressure in the outlet and properties such as for example the temperature and quality of the paste mass can be entered.
- 15 The block diagram illustrated in Figure 6 only shows one example of a closed-loop control according to the invention and is in no way restricted to this. With the invention it is only essential that the inlet valve is the final control element for a closed-loop control of the degree of evacuation of the paste mass, i.e. for a certain air content in the paste mass or of the corresponding compressibility.

**P A T E N T K R A V**

1. Vakuumtragt (1) til pølseproduktion med

5 et indløb (7) til tilførsel af pastøs masse, især pøsefars,

et udløb (13) til bortledning af den pastøse masse,

10 en indløbsventil (3), der er anbragt ved indløbet (7), hvor der i vakuumtragten (1) kan frembringes et undertryk,

**kendetegnet ved, at**

15 indløbsventilen (3) i åbnet tilstand danner en indløbsspalte (S) til den pastøse masse, hvis spaltehøjde (h) kan reguleres til påvirkning af evakueringsgraden af den pastøse masse, hvor reguleringen af indløbsventilen (3) sker via en flerpunktsregulering eller en proportionsregulering.

2. Vakuumtragt ifølge krav 1,

20 **kendetegnet ved, at**

tragten endvidere omfatter en reguleringsindretning (22) til regulering af spaltehøjden (h) i afhængighed af mindst en parameter blandt følgende gruppe:

25 sammentrykkelighed eller luftindhold af den pastøse masse før indløbsventilen (3), sammentrykkelighed eller luftindhold af den pastøse masse efter udløbet (13) eller i vakuumtragten (1), transportkapacitet af et transportværk (14), der er anbragt efter udløbet (13), stykstørrelser af ladninger af den pastøse masse, trykforskel før og efter indløbsventilen (3), fyldkapacitet af den pastøse masse i vakuumtragten, fyldstand af den pastøse masse i vakuumtragten, temperatur af den pastøse masse, viskositet af den pastøse masse.

30

3. Vakuumtragt ifølge krav 1 eller 2,

**kendetegnet ved, at**

vakuumtragten endvidere omfatter en reguleringsindretning til regulering af spaltehøjden (h) i afhængighed af sammentrykkeligheden eller luftindholdet af den pastøse masse før indløbsventilen (3) og/eller efter udløbet (13) og/eller mellem indløbsventil (3) og udløb (13) samt i afhængighed af fyldstandsparametre.

5

4. Vakuumtragt ifølge mindst et af kravene 1 til 3,

**kendetegnet ved, at**

indløbsspalten (S) udviser et cirkelrundt eller elliptisk eller andet lukket tværsnit.

10

5. Vakuumtragt ifølge et af kravene 1 til 4,

**kendetegnet ved, at**

ventilen (3) ved indløbet (7) udviser et ventilsæde (9) og en overfor liggende prelplade (5), hvor afstanden (h) mellem ventilsæde (9) og prelplade (5) giver spaltehøjden (h).

15

6. Vakuumtragt ifølge krav 5,

**kendetegnet ved, at**

ventilen (3) omfatter et drev (4) til prelpladen (5) til indstilling af spaltehøjden (h).

20

7. Vakuumtragt ifølge krav 6,

**kendetegnet ved, at**

diameteren af prelpladen (5) er større end diameteren af ventilsædet (9).

25

8. Vakuumtragt ifølge mindst et af kravene 5 til 7,

**kendetegnet ved, at**

prelpladen (5) er udformet således, at den dirigerer den pastøse masse nedad henholdsvis skråt nedad i retning af udløbet (13).

30

9. Vakuumtragt ifølge mindst et af kravene 5 til 8,

**kendetegnet ved, at**

prelpladen (5) er udformet således, at den på den mod ventilens (9) rettede side omfatter en udsparring (6), der i det mindste i det ydre område af indløbsspalten (S) udviser et afsnit (A), der hælder skråt nedad eller nedad fra midteraksen (M) af ventilen.

5

10. Vakuumtragt ifølge krav 8,

**kendetegnet ved, at**

udsparringen (6) har en i det væsentlige konkav form eller forløber ringformet om midteraksen (M) af ventilen (3).

10

11. Vakuumtragt ifølge mindst et af kravene 5 til 10,

**kendetegnet ved, at**

indløbet (7) i det øvre område af vakuumtragten (1) er dannet i form af et tilløbsrør (8), hvis åbne ende rager ind i vakuumtragten (1) og vender opad, hvor prelpladen (5) ligger over for den åbne ende.

15

12. Vakuumtragt ifølge mindst et af kravene 1 – 11,

**kendetegnet ved, at**

der endvidere før indløbsventilen (3) og/eller efter udløbet (13) af vakuumtragten (1) eller i vakuumtragten er anbragt en indretning til bestemmelse af sammentrykkeligheden af den pastøse masse henholdsvis luftindholdet (16).

20

13. Vakuumtragt ifølge mindst et af kravene 1 – 12,

**kendetegnet ved, at**

der i vakuumtragten (1) endvidere er anbragt en fyldstandsmåler (21).

25

14. Vakuumtragt ifølge mindst et af kravene 1 – 13,

**kendetegnet ved, at**

der før og efter indløbsventilen er tilvejebragt en trykføler.

30

15. Vakuumpåfyldningsapparat (100) med en vakuumtragt (1) ifølge mindst et af kravene 1 til 10 samt

et transportværk (14), der leder den pastøse masse bort fra udløbet (13) af vakuumtragten (1) og skubber den ind i et påfyldningsrør (15) for at fylde pølser med den pastøse masse,

en vakuumpumpe til frembringelse af et undertryk i transportværket og/eller i vakuumtragten.

16. Fremgangsmåde til fyldstandsregulering og til reguleret evakuering af pastøse masser, især pølsefars, med følgende trin:

tilførsel af pastøs masse til en vakuumtragt (1) via en indløbsventil (3), bortledning af pastøs masse via et udløb (13) af vakuumtragten (1), hvor der frembringes et undertryk i vakuumtragten, **kendetegnet ved**

regulering af højden af indløbsspalten (S) af den åbnede indløbsventil (3) til påvirkning af evakueringsgraden af den pastøse masse, hvor reguleringen af indløbsventilen (3) sker via en flerpunktsregulering eller proportionsregulering.

17. Fremgangsmåde ifølge krav 16,

**kendetegnet ved, at**

den pastøse masse ledes bort fra udløbet (13) ved hjælp af et transportværk (14), og transportværket skubber den pastøse masse til fyldning af pølser ind i et påfyldningsrør.

18. Fremgangsmåde ifølge krav 16 eller 17,

**kendetegnet ved, at**

spaltehøjden (h) reguleres i afhængighed af sammentrykkeligheden henholdsvis luftindholdet af den pastøse masse før indløbsventilen (3) og/eller efter udløbet

(13) af vakuumtragten og/eller mellem indløbsventil (3) og udløb (13) og i afhængighed af fyldstandsparametre.

19. Fremgangsmåde ifølge krav 16 eller 17,

5 **kendetegnet ved, at**

spaltehøjden (h) reguleres i afhængighed af mindst en af de følgende parametre:

10 sammentrykkelighed eller luftindhold af den pastøse masse før indløbsventilen (3), sammentrykkelighed eller luftindhold af den pastøse masse efter udløbet (13) eller i vakuumtragten, fyldkapacitet af den pastøse masse i vakuumtragten, stykstørrelser af ladninger af massen, trykforskel før og efter indløbsventilen (3), fyldstand, transportkapacitet af et transportværk (14), der er anbragt ved udløbet (13), temperatur af den pastøse masse, viskositet af den pastøse masse.

15

20. Fremgangsmåde ifølge et af kravene 16 til 19,

**kendetegnet ved, at**

20 der til regulering af spaltehøjden (h) af indløbsspalten (S) gennemføres en spalte-regulering, hvor indløbsspalten (S) indstilles således, at den er så stor som nødvendig til fyldstandsregulering og så lille som påkrævet til regulering af evakueringsgraden.

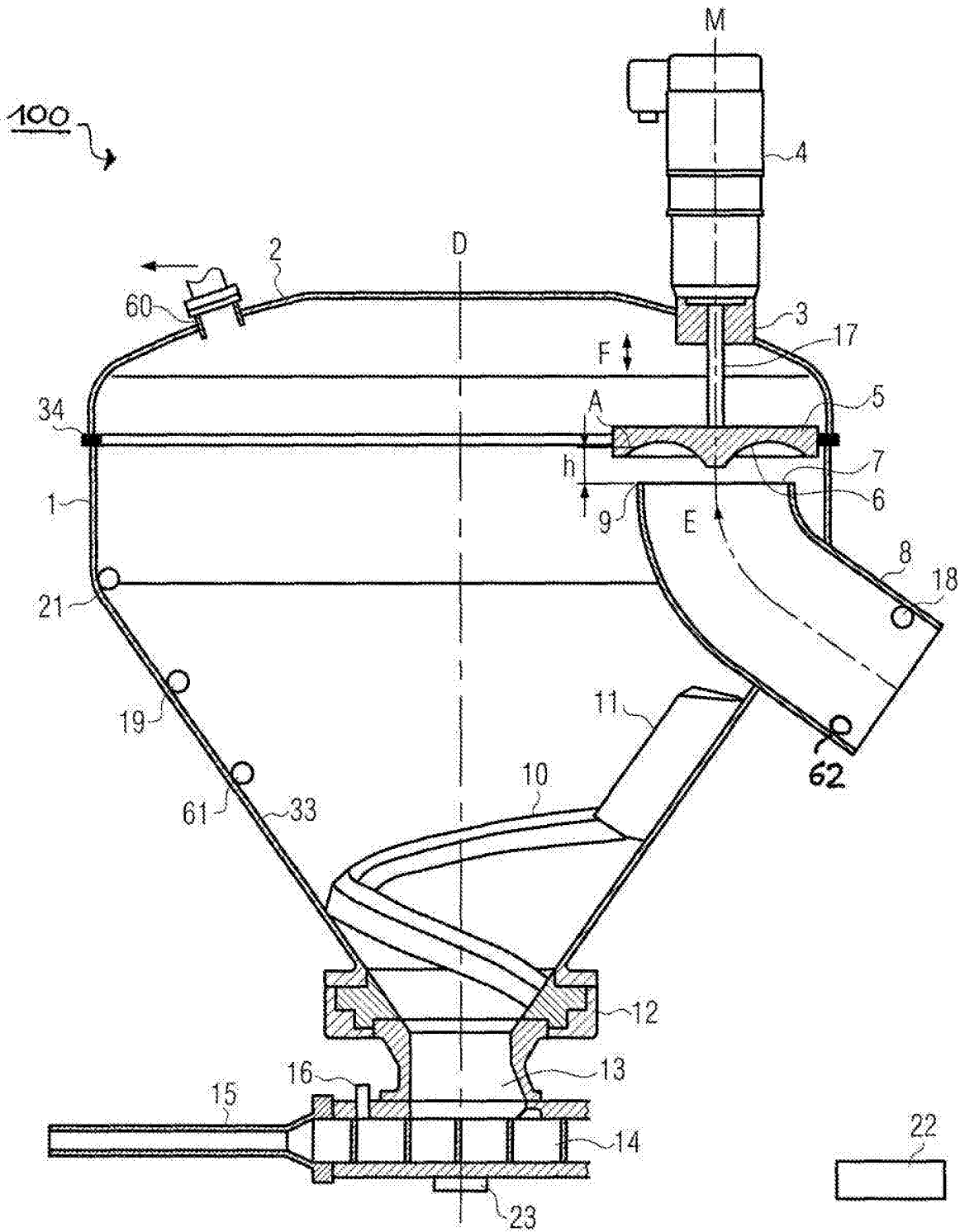

FIG. 1

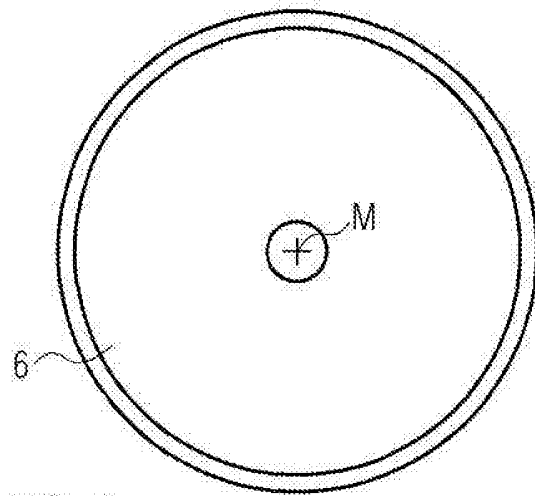

FIG. 2

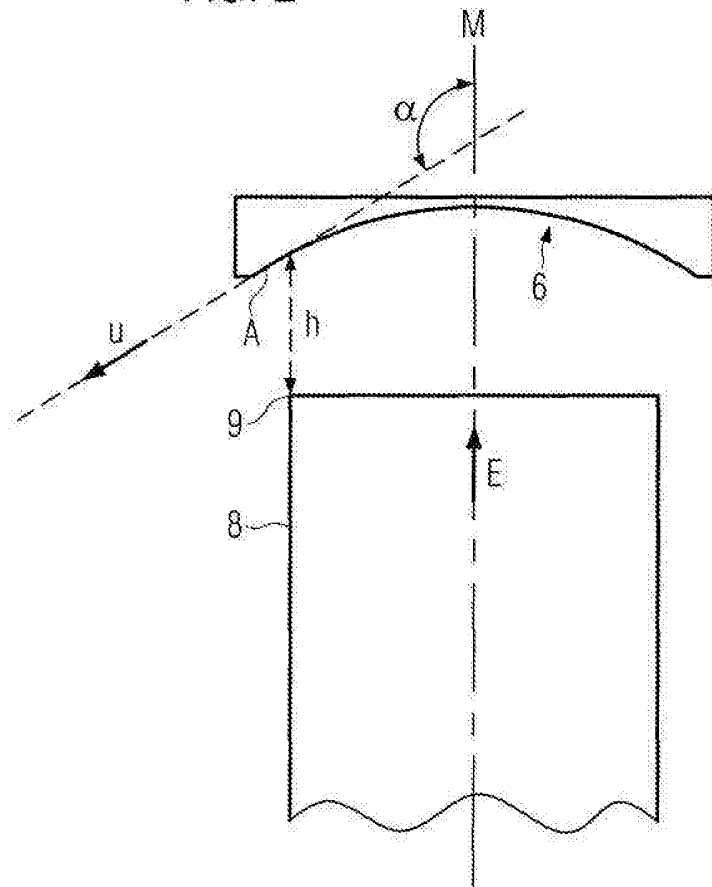

FIG. 3

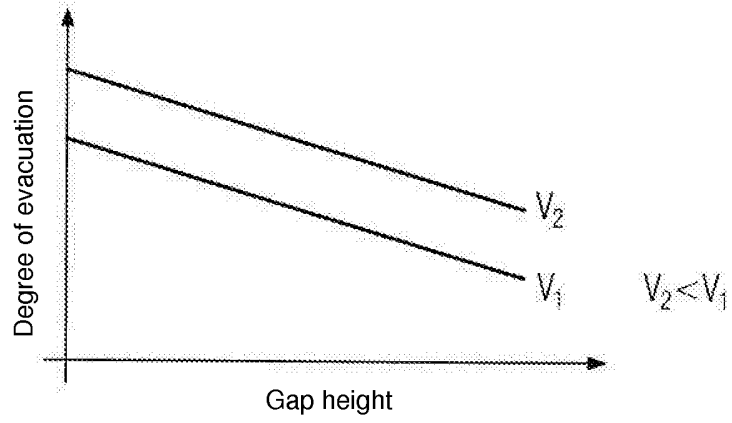

FIG. 4

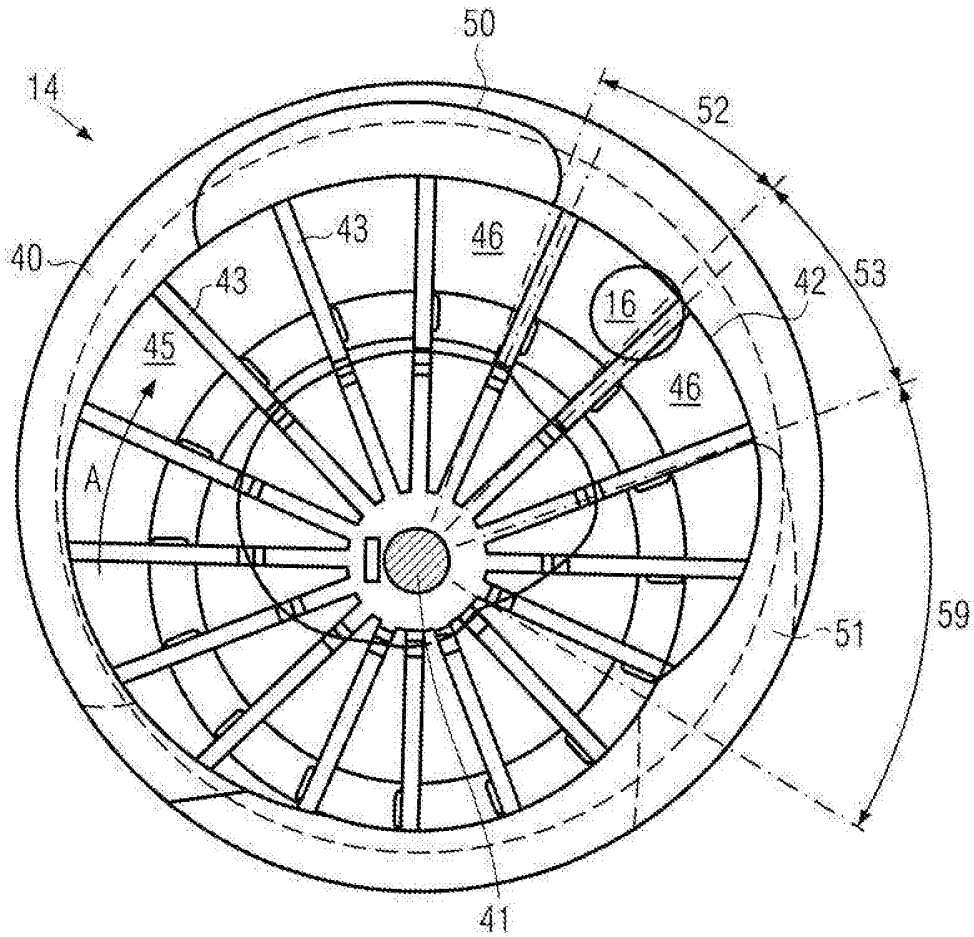

FIG. 5

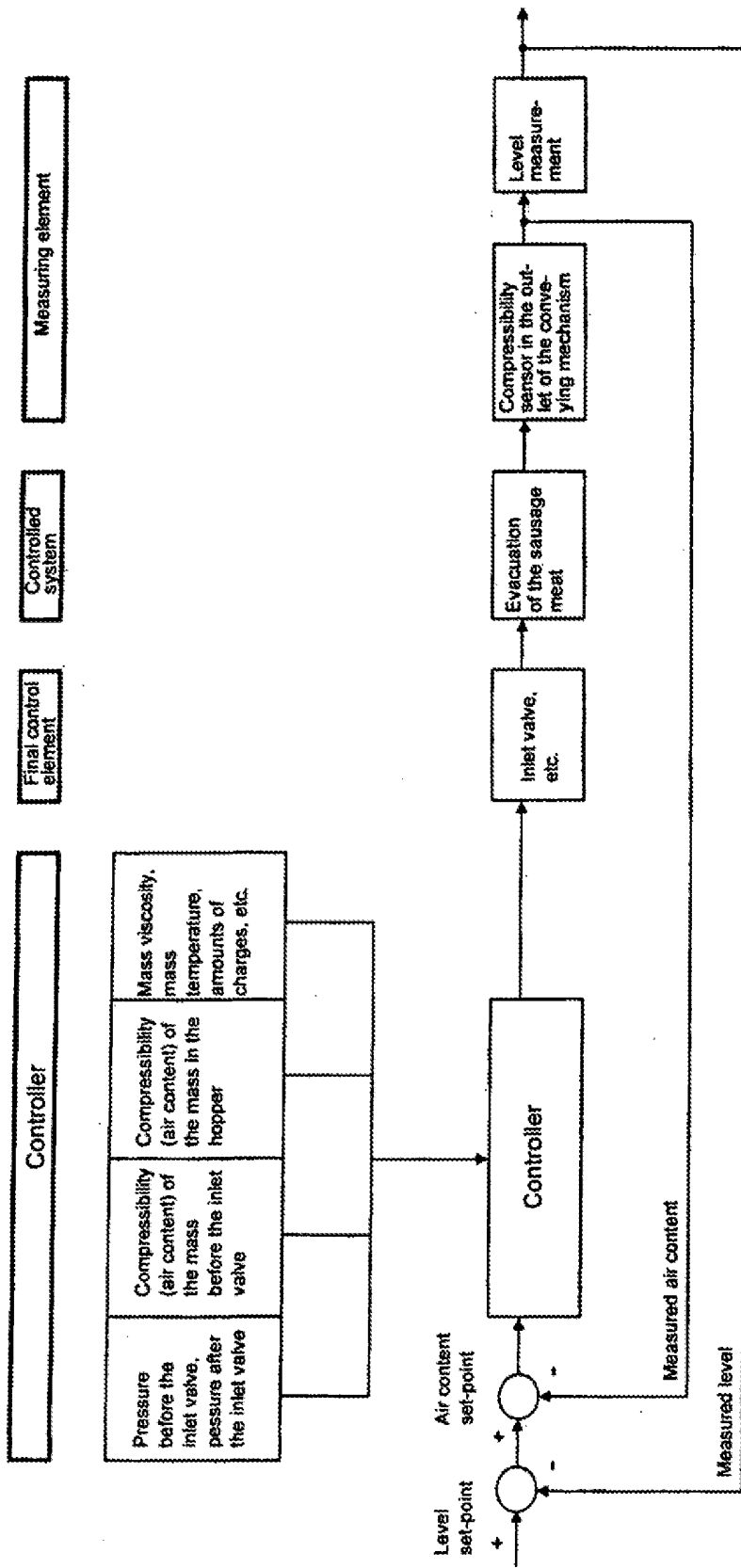

FIG. 6