

Dec. 3, 1968

M. WEBER

3,414,160

REDUCED-PRESSURE BOX

Filed April 24, 1967

**Fig. 1**

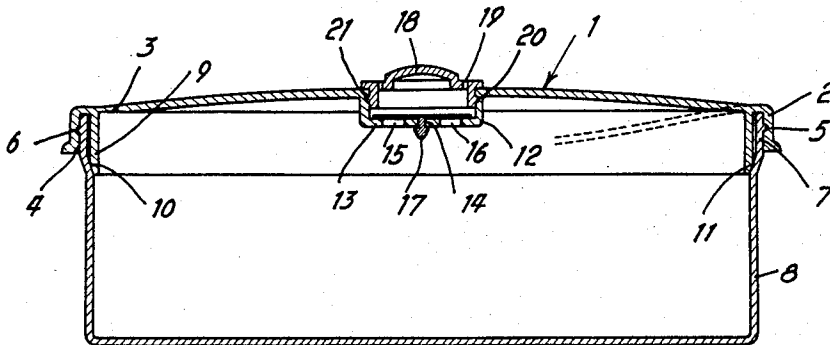

**Fig. 2**

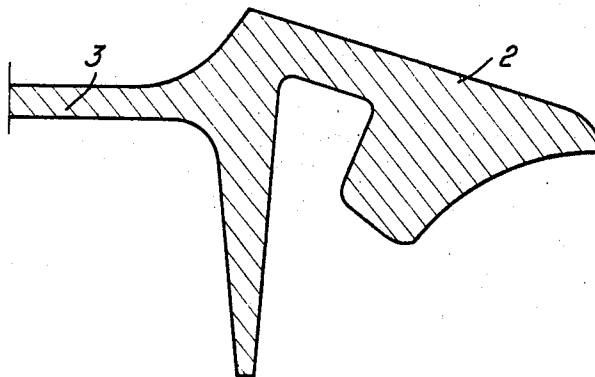

1

3,414,160

**REDUCED-PRESSURE BOX**

Michel Weber, 5 Rue Alphonse Bordereau 77,  
Chelles, France

Filed Apr. 24, 1967, Ser. No. 633,079

Claims priority, application France, Apr. 26, 1966,  
59,080

3 Claims. (Cl. 220-44)

**ABSTRACT OF THE DISCLOSURE**

A reduced pressure box of the type having a cover adapted to create a partial vacuum when being positioned on said box, said cover having at least a hole and being provided with a flexible diaphragm seated over said hole whereby forming a check-valve and providing the exhaust of the air from the interior of the box when a reciprocating motion is imparted to said cover.

The present invention relates to a reduced-pressure box, that is to say to a box in which a partial vacuum can be created at the moment when the cover is placed in position, and which comprises a certain number of improvements with respect to comparable boxes of the prior art.

The aim of this invention is to endow such boxes with a certain number of features which can be utilized separately but which secure the maximum number of advantages when they are utilized in combination.

In accordance with one of the features referred to, the cover is pierced by at least one hole against which is applied a flexible diaphragm forming a check-valve whereby the air which is present inside the box can be exhausted from the interior of the box to the surrounding atmosphere when a reciprocating motion is imparted to the box cover, the edge of which serves as a virtual hinge.

In order to facilitate the reciprocating motion referred to, the portion which forms a hinge is advantageously thinned and the cover is outwardly bulged in such a manner as to permit a certain amount of deflection.

In order to ensure perfect air-tightness of the cover, the invention additionally makes provision for the fact that the peripheral portion or flange which is intended to fit over the rim of the box has a cross-section of greater thickness than that of the remainder of said cover and can even attain a thickness which is five or six times greater. In this case, the initial fitting of the cover over the box is carried out in the hot state immediately after delivery from the forming mold, with the result that the very substantial shrinkage of the thick peripheral portion of the cover which takes place at the time of cooling causes the cover to be very powerfully applied against the side wall of the box, thereby resulting in perfect airtightness during use.

The hole or holes of the cover can be formed in a central boss which projects inwardly from said cover and the flexible diaphragm can be a simple disc fitted with a central element constituting a press-button which is forcibly inserted in a corresponding hole formed in said boss.

In order to facilitate the positioning of the cover on the box, there is preferably formed on said cover an internal projecting portion of cylindrical shape which is concentric with the cover flange proper and the extremity of which forms a cam for the purpose of centering the cover against the rim of the box. Moreover, the base of the outer flange of the cover will preferably be chamfered in order to take part in the guiding action.

Further properties and advantages of the invention will become apparent from the following description of one

2

example of execution which is given without implied limitation, reference being made to the accompanying drawings, in which:

FIG. 1 is an axial sectional view of a reduced-pressure box according to the invention;

FIG. 2 is a detail view on a larger scale and in radial cross-section showing the flange of a cover having a bulged cross-sectional configuration.

In the example which is illustrated, the cover 1 is outwardly bulged and is joined to the flange 2 by means of a zone 3 of reduced thickness which is intended to form a hinge. The turned-down edge or flange 2 is provided at its base with a chamfered portion 4 and in its internal wall with a small groove 5 which is intended to accommodate a rib 6 formed on the rim 7 of the box body 8.

At a distance from the internal wall of the flange which is slightly greater than the thickness of the rim 7, the cover 1 is provided with a projecting internal cylindrical portion 9 having a depth which is greater than that of the outer flange 2 and the extremity 10 of which is chamfered so as to form a cam by cooperating with the sloping section 11 of the box body 8.

The cover 1 is provided at its center with a cup-shaped boss, there being formed in the base 13 of said boss a central hole 14 and radial slots 15. A circular rubber diaphragm 16 is applied against said base 13 and is fitted with a central press-button 17 which is intended to fit inside the hole 14. There can be mounted over the cup 12 a cap 18 which is pierced by air holes 19 and provided with a small peripheral rib 20 which is adapted to engage in a corresponding groove 21 of the internal side wall of the cup 12.

It is apparent that the positioning of the cover 1 which has just been described is greatly facilitated on the one hand by virtue of the projecting portion 9 and its extremity 10 which performs the function of a cam by cooperating with the sloping section 11 of the box body and, on the other hand, by virtue of the chamfered edge 4 of the base of the outer flange 2.

The pumping motion which is produced by the cover is carried out very readily by virtue of the reduced thickness of the zone 3 which constitutes a virtual hinge and the valve system is so designed as to permit of easy disassembly and cleaning.

In the example of FIG. 2, there is shown a portion of cover 1 in which the thickness of the flange is considerably greater than that of the top wall of said cover. A cover of this type which has initially been fitted over the box in the hot state is closely applied against the walls of the box at the time of cooling as a result of the greater degree of shrinkage of its flange 2, thereby ensuring perfect airtightness.

As will be readily understood, the invention is not limited in any sense to the constructional details which have been illustrated or described and which have been given solely by way of example. It accordingly follows in particular that the cross-section of the cover flange could have any shape and could be rectangular, for example.

What I claim is:

1. A vacuum container of the type having an open mouth delimited by a peripheral rim, a cover provided with a central opening and adapted to be set on said rim in an air-tight way, and to be imparted an inwardly directed motion whereby providing exhaust of air from the interior of the container, and a flexible diaphragm fixed to said cover and adapted to close said opening for preventing entrance of air into said container, said cover being further provided with a central removable cap having at least one hole and mounted over said diaphragm whereby protecting said diaphragm, and allowing air to escape through said hole and allowing a thrust to be

3

exerted on said cap for imparting said inwardly directed motion to said cover.

2. A container as in claim 1 wherein said cover comprises an inner projecting peripheral portion and an outer projecting peripheral portion delimiting an annular groove and adapted to be set over said rim of said container, said inner portion and said outer portion being substantially parallel and said outer portion having a cross-section of much greater thickness than that of the remainder of said cover whereby permitting the initial fitting of said cover over said edge in the hot state immediately after molding and ensuring a perfect air tightness after cooling through a substantial shrinkage of said thicker outer peripheral portion.

3. A container as in claim 2 wherein said inner projecting peripheral portion is of a substantially cylindrical shape with a slightly decreasing section and said outer

4

projecting portion is of a smaller height than said inner portion and comprises a locking part cooperating with a corresponding part of said container rim.

#### References Cited

##### UNITED STATES PATENTS

2,630,237	3/1953	Rosenlof	-----	220—24
2,772,018	11/1956	Weiss	-----	220—44
2,916,173	12/1959	Klingler	-----	220—44 X
3,055,536	8/1962	Dieny	-----	220—44

##### FOREIGN PATENTS

843,804	7/1952	Germany.
1,038,888	9/1958	Germany.

GEORGE E. LOWRANCE, *Primary Examiner.*