

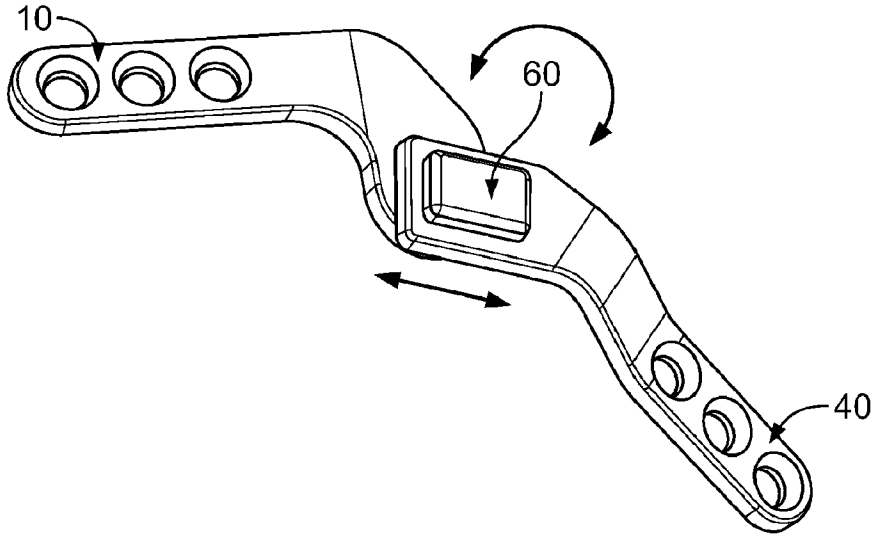

(86) Date de dépôt PCT/PCT Filing Date: 2014/03/10
 (87) Date publication PCT/PCT Publication Date: 2014/09/18
 (45) Date de délivrance/Issue Date: 2021/10/26
 (85) Entrée phase nationale/National Entry: 2015/09/10
 (86) N° demande PCT/PCT Application No.: IB 2014/001242
 (87) N° publication PCT/PCT Publication No.: 2014/140928
 (30) Priorités/Priorities: 2013/03/11 (US61/776,735);
 2013/03/12 (US61/778,324)

(51) Cl.Int./Int.Cl. *A61F 2/30* (2006.01),
A61D 99/00 (2006.01)
 (72) Inventeurs/Inventors:
 BARKOWSKI, VERONICA, CA;
 EMBLETON, NEIL, CA
 (73) Propriétaire/Owner:
 EMBARK ENTERPRISES INC., CA
 (74) Agent: GELSING, SANDER R.

(54) Titre : SYSTEME DE STABILISATION DE GRASSET POUR QUADRUEDE
 (54) Title: QUADRUPED STIFLE STABILIZATION SYSTEM



(57) **Abrégé/Abstract:**

A stifle stabilization system is provided herein. The system comprising a femoral component having a leg portion and bottom portion, the bottom portion including an interconnected coupling member protruding therefrom, an articular sliding insert component defining a channel corresponding in size and shape to at least part of the coupling member, and a tibial component having a first proximal planar portion defining a slot, the slot being of corresponding and complementary shape to the articular sliding insert component to receive the articular sliding insert component therein, wherein, when the channel receives the at least part of the coupling member and the articular sliding insert component is received in the slot of the tibial component, the tibial component is interlocked with the femoral component with translational and rotational movement therebetween.

(12) INTERNATIONAL APPLICATION PUBLISHED UNDER THE PATENT COOPERATION TREATY (PCT)

(19) World Intellectual Property
Organization
International Bureau



(10) International Publication Number
WO 2014/140928 A3

(43) International Publication Date
18 September 2014 (18.09.2014)

(51) International Patent Classification:

A61F 2/30 (2006.01) *A61D 99/00* (2006.01)

(21) International Application Number:

PCT/IB2014/001242

(22) International Filing Date:

10 March 2014 (10.03.2014)

(25) Filing Language:

English

(26) Publication Language:

English

(30) Priority Data:

61/776,735 11 March 2013 (11.03.2013) US
61/778,324 12 March 2013 (12.03.2013) US

(71) Applicant: EMBARK ENTERPRISES, INC. [CA/CA];
Box 27 Site 9 RR 2, Sundre, AB T0M 1X0 (CA).

(72) Inventors: EMBLETON, Neil; Box 27 Site 9 RR 2, Sundre, AB T0M 1X0 (CA). **BARKOWSKI, Veronica;** Box 27 Site 9 RR 2, Sundre, AB T0M 1X0 (CA).

(74) Agent: VICKERS, Mark, F.; Borden Ladner Gervais LLP, World Exchange Plaza, 100 Queen Street, Suite 1300, Ottawa, Ontario K1P 1J9 (CA).

(81) Designated States (*unless otherwise indicated, for every kind of national protection available*): AE, AG, AL, AM,

AO, AT, AU, AZ, BA, BB, BG, BH, BN, BR, BW, BY, BZ, CA, CH, CL, CN, CO, CR, CU, CZ, DE, DK, DM, DO, DZ, EC, EE, EG, ES, FI, GB, GD, GE, GH, GM, GT, HN, HR, HU, ID, IL, IN, IR, IS, JP, KE, KG, KN, KP, KR, KZ, LA, LC, LK, LR, LS, LT, LU, LY, MA, MD, ME, MG, MK, MN, MW, MX, MY, MZ, NA, NG, NI, NO, NZ, OM, PA, PE, PG, PH, PL, PT, QA, RO, RS, RU, RW, SA, SC, SD, SE, SG, SK, SL, SM, ST, SV, SY, TH, TJ, TM, TN, TR, TT, TZ, UA, UG, US, UZ, VC, VN, ZA, ZM, ZW.

(84) Designated States (*unless otherwise indicated, for every kind of regional protection available*): ARIPO (BW, GH, GM, KE, LR, LS, MW, MZ, NA, RW, SD, SL, SZ, TZ, UG, ZM, ZW), Eurasian (AM, AZ, BY, KG, KZ, RU, TJ, TM), European (AL, AT, BE, BG, CH, CY, CZ, DE, DK, EE, ES, FI, FR, GB, GR, HR, HU, IE, IS, IT, LT, LU, LV, MC, MK, MT, NL, NO, PL, PT, RO, RS, SE, SI, SK, SM, TR), OAPI (BF, BJ, CF, CG, CI, CM, GA, GN, GQ, GW, KM, ML, MR, NE, SN, TD, TG).

Published:

— *with international search report (Art. 21(3))*

(88) Date of publication of the international search report:

8 January 2015

(54) Title: QUADRUPED STIFLE STABILIZATION SYSTEM

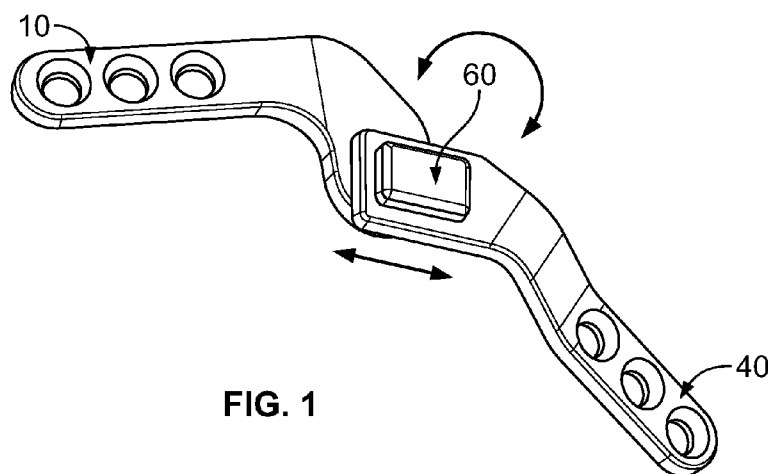

FIG. 1

(57) Abstract: A stifle stabilization system is provided herein. The system comprising a femoral component having a leg portion and bottom portion, the bottom portion including an interconnected coupling member protruding therefrom, an articular sliding insert component defining a channel corresponding in size and shape to at least part of the coupling member, and a tibial component having a first proximal planar portion defining a slot, the slot being of corresponding and complementary shape to the articular sliding insert component to receive the articular sliding insert component therein, wherein, when the channel receives the at least part of the coupling member and the articular sliding insert component is received in the slot of the tibial component, the tibial component is interlocked with the femoral component with translational and rotational movement therebetween.



WO 2014/140928 A3

QUADRUPED STIFLE STABILIZATION SYSTEM

SPECIFICATION

BACKGROUND OF THE INVENTION

CROSS-REFERENCE TO RELATED APPLICATIONS

This application claims the benefit of U.S. Provisional Patent Application No. 61/776,735, filed on March 11, 2013 and U.S. Provisional Patent Application No. 61/778,324, filed on March 12, 2013.

TECHNICAL FIELD

The present invention relates to a method and apparatus for veterinary orthopedic surgical stabilization of an unstable quadruped stifle joint.

RELATED ART

The quadruped stifle is a complex and powerful joint that is stabilized by four main ligaments (e.g., the cranial cruciate, the caudal cruciate, the medial collateral, and the lateral collateral). The stifle joint is further stabilized by the patella and the tendons associated therewith and the surrounding musculature. These powerful ligaments and tendons bind the femur and tibia together. Although the structure of the stifle provides one of the strongest joints of the quadruped body, as in humans, the stifle joint is also one of the most frequently injured joints. The most frequent injury occurs to the cranial cruciate ligament.

The canine is the most frequently affected quadruped species. The large number of canine cranial cruciate ligament injuries has given rise to a considerable number of innovative surgical procedures and devices for attempting to replace the partially or completely torn or avulsed cranial cruciate ligament. A partially, or completely torn, stifle associated ligament or tendon typically results in serious clinical symptoms (e.g., stifle swelling and inflammation, significant stifle pain, disuse muscular atrophy, radiographic evidence of arthritis and stifle joint instability, etc.) resulting in a significantly diminished ability to perform high level, or daily activities relating to mobility. The inevitable long

term effects of a damaged and unstable quadruped stifle joint include significant meniscal and articular cartilage damage to the femur, tibia, and patella. This leads to chronic pain and debilitating degenerative joint disease.

Injury (or disruption) of any of the ligaments or tendons (including the cranial cruciate ligament) of the quadruped stifle typically requires a major surgical intervention to address the injury. Historically and currently these attempts at repair have involved both intra-articular and extra-articular repair procedures with varying degrees of success. More recently geometric modification of the canine stifle joint has been advocated.

Several types of surgical procedures have been developed and are currently in use to attempt to mitigate the instability of the canine stifle caused by the damaged cranial cruciate ligament and/or other ligaments and tendons. Although primary cranial cruciate ligament repair would be ideal, it is unfortunately not a viable option in veterinary medicine for a number of reasons (e.g., cranial cruciate injury in quadrupeds is rarely acute, the injury is usually a chronic injury/disease that progresses over time and the amount of trauma that occurs to the cranial cruciate ligament is usually very severe). As a result the torn ends of the cranial cruciate ligament are not of a sufficient length to reattach successfully or have been resorbed to an extent that reattachment is not possible.

Historically intra-articular stabilization of the cranial cruciate deficient canine stifle was performed via placement of an autogenous graft, harvested either from the patella tendon or the tensor fascia lata. This method involved harvesting of the graft and then tunnelling the graft through the stifle joint and attaching so that it mimics the cranial cruciate ligament. This method has fallen out of favor due to the invasiveness of the surgical procedure required, the inherent weakness of the graft and high rate of failure of the autogenous grafting material.

Other current techniques, although purported to be extra-capsular (e.g., outside the joint) repair methods are actually intracapsular repair methods. Numerous terms and techniques are utilized. One technique utilizes a synthetic nylon (e.g., commercial fishing line) or a braided polymer material to prevent cranial tibial thrust. These materials both generally ultimately fail to prevent cranial tibial thrust. The nylon material cycles, weakens, and either stretches or breaks due to movement of the stifle joint, or will tear through the surrounding soft tissues. The braided polymer material, while much stronger, either breaks, cuts through the bone, or as a result of being braided, becomes infected. These current techniques have been successful in reducing abnormal femoral/tibial

movement in a sagittal plane. However, neither of these current extra-capsular repair techniques permits the tibia, in relation to the femur, to internally and externally rotate as in a normal joint, nor do they permit normal compression and extension. These techniques also cause a valgus deformation of the tibia relative to the femur.

Another class of cranial cruciate repair surgery is the geometric modification of the quadruped stifle joint, which relied upon the idea that the stifle joint would be dynamically stabilized by altering either the slope of the proximal tibia, or the position of the tibial tuberosity. There are currently two accepted geometric modification procedures (e.g., the tibial plateau leveling surgical osteotomy (TPLO) of the proximal tibia and tibial tuberosity advancement (TTA)). The TPLO procedure involves a full thickness semi-circular osteotomy below the proximal tibia. The proximal portion of the tibial bone is then rotated counter-clockwise to decrease the tibial slope and therefore, associated cranial tibial thrust. The rotated bone is fixed in place using a specialized bone plate. The TTA procedure involves an angled, vertical cut of the tibial tuberosity. The freed portion is then advanced and fixed into place using specialized bone plating equipment. Both procedures require a very invasive surgical procedure that accomplishes its goal of decreasing cranial tibial thrust by either, transposing or rotating the cut proximal piece of tibia.

The current issues surrounding these repair methods center around the requirement that either the caudal cruciate (TPLO) or the central patellar tendon (TTA) is required to act as the cranial cruciate ligament, which is a task that neither tissue was designed to do. Other issues with geometric repair methods include the limited access of veterinarians capable of performing the procedures due to the specialized training and expensive equipment required for both the TPLO and TTA procedures. These procedures have been purported to dynamically stabilize the unstable stifle joint, but new research indicates that this is simply not the case and that the stifle joint remains unstable for a large portion of the stride. These procedures also do not limit the internal rotation of the tibia relative to the femur, which is one of the primary jobs of the quadruped, cranial cruciate ligament. This is particularly important when considering that during certain parts of the stride, the quadruped stifle joint is non-weight bearing and unsupported. It is during this non-weight bearing period that internal rotation of the tibia is unrestricted greatly increasing the risk that additional quadruped stifle joint trauma can, will, and does, occur at this time.

Other ligament or tendon injuries to the quadruped stifle require different procedures to repair the damage. Many of these procedures have varying success rates.

To date no one procedure exists to stabilize unstable, injured, and fractured quadruped stifles. Accordingly, what is needed is a method of providing continuous support to the damaged, quadruped stifle during both non weight bearing and full weight bearing phases of the stride.

SUMMARY

A surgical procedure and apparatus is provided for biocompatible, extracapsular, modular surgical stifle stabilization that can be permanently, or temporarily, surgically implanted on the medial side of the distal femur and proximal tibia to stabilize an unstable, quadruped, stifle joint. The system provides continuous resistance to abnormal cranial or caudal tibial thrust while not interfering with normal movement of the quadruped stifle.

The apparatus provides continuous support to the injured quadruped stifle, while permitting the quadruped stifle to move in a normal manner during all phases of the quadruped stride. The apparatus offers continuous support and permits normal flexion and extension, normal internal and external rotation, normal compression and expansion of the quadruped stifle joint during all phases of the stride. This procedure and apparatus could be used for a cranial cruciate rupture, caudal cruciate rupture, medial collateral rupture, lateral collateral rupture, medial patellar luxation, lateral patellar luxation, patellar tendon avulsion, patellar fracture, proximal tibial fracture, distal femoral fracture, stifle disruption, and any combination thereof, or any degree of any of the above conditions.

BRIEF DESCRIPTION OF THE DRAWINGS

The foregoing features of the disclosure will be apparent from the following Detailed Description of the Disclosure, taken in connection with the accompanying drawings, in which:

FIG. 1 is a perspective view of the apparatus of the present disclosure fully assembled, including the femoral component, the tibial component, and the articular sliding insert component;

FIG. 2 is a bottom perspective view of the apparatus shown in **FIG. 1**;

FIGS. 3A-3E are perspective, front, back, side, and exploded perspective views, respectively, of the femoral component;

FIG. 3F is a cross-section view taken along line F-F in **FIG. 3B**;

FIG. 3G is a cross-section view taken along line G-G in **FIG. 3D**;

FIGS. 4A-4C are side, front, and perspective views, respectively, of the tibial component and the articular sliding insert component;

FIGS. 5A-5E are perspective, top, front, side, and bottom views, respectively, of the articular sliding insert component;

FIGS. 6A-6C are perspective, side, and bottom views, respectively, of the femoral coupling member of the apparatus;

FIG. 7 is a perspective view of the articular sliding insert component positioned to receive the femoral ball attached to the femoral component;

FIG. 8 is a perspective view of the femoral ball positioned in the articular sliding insert component;

FIG. 9 is a perspective view of the tibial component positioned to receive the articular sliding insert component;

FIG. 10 is a perspective view of another aspect of a fully assembled apparatus;

FIG. 11 is a perspective view of another aspect of the apparatus fully assembled;

FIG. 12 is a side view of the apparatus shown in **FIG. 11**;

FIGS. 13A-13C are perspective, rear, and side views of the femoral component shown in **FIG. 11**;

FIG. 14 is a perspective view of the tibial component shown in **FIG. 11**;

FIG. 15 is a perspective view of the articular sliding insert component shown in **FIG. 11**; and

FIGS. 16-17 are partial perspective views of another aspect of the apparatus fully assembled.

DETAILED DESCRIPTION

A modular surgically implanted apparatus is disclosed that can be used in canine, feline, and other quadruped animal species (e.g., domestic or exotic) to stabilize an unstable quadruped stifle joint that may be due to any number of causes (e.g., soft tissue or hard tissue injury of the stifle ligaments, tendons and their attachments and surrounding structures). The modular device (e.g., canine internal stifle stabilizing system) can be surgically implanted on a temporary or permanent basis to provide veterinary orthopedic surgical stabilization of a stifle joint (e.g., quadruped stifle joint). The system stabilizes the unstable stifle joint during all phases of the stride and allows normal stifle flexion, extension, internal rotation, external rotation, joint compression and expansion, varus and valgus movement, while continuously impeding abnormal cranial tibial thrust during all phases of the stride. The system works for primary treatment (e.g., stabilize a quadruped stifle) for a partial or complete cranial cruciate ligament injury (e.g., rupture) or avulsion, a partial or complete caudal cruciate ligament injury (e.g., rupture) or avulsion, a partial or complete medial collateral ligament injury (e.g., rupture) or avulsion, a partial or complete lateral collateral ligament injury (e.g., rupture) or avulsion, a congenital or traumatic medial patellar luxation or avulsion, a congenital or traumatic lateral patellar luxation or avulsion, a congenital or traumatic patellar tendon avulsion, a patellar fracture, a traumatic fracture to either the distal femur or proximal tibia, or any combination thereof (e.g., all of the above).

A stifle stabilizing system is provided as a modular, stifle stabilizing device that can be permanently or temporarily surgically implanted and attached onto the medial side of the distal femur and proximal tibia of quadrupeds. The components of the system are interdependent and interconnected. The system permits normal stifle joint movement in all planes, while continually providing support. All components of the stifle stabilizing system could be made of a biocompatible surgical material. The stabilizing device is centered over the medial aspect of the quadruped stifle joint.

The device includes a femoral component, a tibial component, and an articular sliding insert component. The tibial and femoral components are fastened to the medial aspect of the femur and tibia by a varying number of fasteners. The distal end of the femoral component contains a coupling member, which could be permanently attached to the femoral component. The coupling member provides multiple degrees of movement,

while remaining completely captured, as explained in more detail below. Although the drawings depict the coupling member as a ball and stem, any other suitable coupling member could be used, such as 'T' and groove, disc and sleeve, etc. Further, the coupling member could be any shape that could fit into the slot of the articular sliding component and allow rotation and twisting between the femoral component and tibial component, such as any shape with a rounded type surface (e.g., oval, oblong, etc.).

The proximal tibial component has a rectangular space that accepts and holds the articular sliding insert component, such as by a pressure fit into the rectangular space provided on the proximal tibial component. The articular sliding insert component includes a groove (e.g., channel) that receives the ball to lock the femoral and tibial components together. The articular sliding insert component also includes a flange on the underside thereof. In operation, the flange is located between the femoral and tibial components and has a bevelled edge (e.g., a ten degree bevelled edge) on either side, allowing for (and limiting) maximum internal and external rotation of the stabilized stifle joint. The system permits normal stifle joint movement in all planes, while continually providing support.

When assembled and implanted in a patient, the articulation between the components of the stifle stabilizing system ensures that the implant allows, and does not impede, the normal range of motion, normal compression and expansion, normal valgus and varus movement and normal external and internal rotation of the quadruped stifle, while continuously stabilizing the stifle joint and thereby preventing abnormal tibial thrust in all phases of the stride. The system provides continuous support and stabilization (e.g., of a tibia relative to a femur) and allows for (and does not inhibit) the normal extension (e.g., about 160 degrees) and flexion (e.g., about 40 degrees) range of motion of the stifle joint (e.g., tibia in relation to the femur), during any phase (e.g., weight bearing and non-weight bearing) of the stride. In the canine patient, the angle of the stifle is measured from the lateral side, and is the angle formed by intersecting lines bisecting the centers of the femur and tibia. In the normal canine, the stifle range of motion is approximately from one hundred and sixty (160) degrees in full extension to approximately forty (40) degrees in full flexion.

The system of the present disclosure provides for normal internal (e.g., approximately 10 degrees) and external (e.g., approximately 10 degrees) tibial rotation. Tibial rotation is measured as the amount of inward or outward twisting of the tibia relative

to the femur. The normal canine tibia has 10 degrees of valgus and varus movement relative to the femur.

FIG. 1 is a perspective view of the assembled system of the present disclosure, and **FIG. 2** is a back perspective view of the system shown in **FIG. 1**. The system is a surgically implantable, modular stifle stabilizing device comprising a femoral component **10**, a tibial component **40**, and an articular sliding insert component **60**. Each stabilizing component can be separately manufactured/machined and then interconnected. More specifically, the femoral component interconnects with the tibial component via the articular sliding insert component. These connections between the components allow the individual components to maintain the normal range of motion and normal external and internal rotation of the quadruped stifle (e.g., canine, feline, etc.), while continuously stabilizing the stifle joint. As indicated by the arrows, and as explained in further detail below, the femoral component **10** translates along the channel of the articular sliding insert component **60**, and the tibial component **40** rotates about the ball of the femoral component **10**.

FIGS. 3A-3E are perspective, front, back, side, and exploded perspective views, respectively, of the femoral component **10**. **FIG. 3F** is a cross-section view taken along line F-F in **FIG. 3B**, and **FIG. 3G** is a cross-section view taken along line G-G in **FIG. 3D**. As shown in **FIG. 3A-3C**, the femoral component **10** is a form fitting (e.g., precontoured and contourable), hockey stick shaped, curved component that conforms, and can be permanently or temporarily attached, to the contour of a femur (e.g., the medial side of the distal third of the femur, medial aspect of the distal femoral diaphysis, etc.).

The femoral component **10** can be made from a number of acceptable, biocompatible, implantable materials (e.g., 316MVL stainless steel, titanium, Ultra High Molecular Weight Polyethylene (UHMWPE), etc.). Exposed edges of the femoral component **10** can be rounded and smooth. The dimensions of the femoral component **10** can vary, such as according to the size of the patient (e.g., based wholly or in part on the body weight of the patient). More specifically, the length, width, and/or thickness of the femoral component **10** can vary with the size of patient (e.g., approximately 25-85 mm in length, approximately 5-45 mm in width, and about 2-3 mm in thickness).

The femoral component **10** includes a leg portion **12** and a bottom portion **14**, which form plane angles with respect to one another (e.g., the general "L" shape) and also form dihedral angles with respect to one another. The leg portion **12** can have front and

back generally planar faces and opposing, generally planar edges. At the distal end, the edges can terminate in a rounded distal edge. The bottom portion **14** includes front and back generally planar faces and an edge that defines a bulbous shape.

The femoral component **10** contains attachment holes in leg portion **12** and an aperture **16** in bottom portion **14**. Any number of attachment holes **12a**, **12b**, and **12c** could be used (e.g., two (2) to three (3) permanent attachment holes). These holes **12a**, **12b**, and **12c** can be aligned and extend through the front and back generally planar faces. The diameter of these holes can vary such that they will accept the appropriate sized screw, or other fastener (e.g., 3.5 mm diameter holes for placement of a 3.5 mm cortical bone screw). The holes **12a**, **12b** and **12c** can be sized to have a sufficient diameter such that the head of the screw (e.g., a 3.5 mm cortical screw), fits flush with the femoral component **10**. Any sized bone screws could be used (e.g., 2.0 mm, 2.7 mm, or 3.5 mm cortical bone screws), and the holes **12a**, **12b**, and **12c** could be sized accordingly. Further, the femoral component **10** could utilize locking technology (e.g., locking screws and locking attachment holes **12a**, **12b**, and **12c**).

As shown in **FIGS. 3A-3E**, a ball **20** and stem **22** are located on the bottom portion **14** of the femoral component **10**. The stem **22** is received by aperture **16**, and the ball **20** extends outward from the outer surface of the bottom portion **14** of the femoral component **10** at approximately 90 degrees. The ball **20** and stem **22** can be formed separately and joined together or they can be of a unitary construction. The stem **22** can be pressure fit into an aperture **16** in the bottom portion **14**, although any suitable attachment method could be used (e.g., aperture **16** and stem **22** could be threadably engaged with one another, a series of laser welds could be used, etc.). The shape of the ball **20** can be varied as desired provided it can interlocked with the tibial component **40**, such as by way of insert component, as will be described below in more detail. The ball **20** provides the stifle joint with continuous support against abnormal tibial thrust during both full extension and full flexion from approximately one hundred and sixty (160) degrees (full extension) to approximately forty (40) degrees (full flexion). The ball **20** and stem **22** form the articulation point for the femoral component **10**.

As shown in **FIG. 3D**, the bottom portion **14** can be positioned at an angle Θ (e.g., dihedral angle) with respect to leg portion **12**. The distal end of the femoral component **10**

can be contoured to the shape of the femoral condyle and could be designed to be elevated away (e.g., 1-2 mm) from the bone of the distal femur (e.g., dihedral angle) so as not to impede femoral soft tissues.

FIG. 3F is a cross-sectional view taken along line F-F on **FIG. 3B** showing an aperture **12B** that could be partially threaded at one area **12BB** while having an unthreaded recessed area **12BA**. Any suitably configured aperture could be used in the femoral or tibial component. **FIG. 3G** is a cross-sectional view taken along line G-G on **FIG. 3D** showing the insertion of the ball **20** and stem **22** discussed in more detail below.

FIGS. 4A-4C are side, front, and perspective views, respectively, of the tibial component **40** and the articular sliding insert component **60**. The tibial component **40** conforms to the contours of a tibia (e.g., proximal medial tibia). The tibial component **40** can be made from a number of acceptable, biocompatible, implantable materials (e.g., 316MVL stainless steel, titanium, UHMWPE, etc.). Exposed edges of the tibial component **40** can be rounded and smooth. The length, width, and thickness of the tibial component **40** can vary with the size of patient (e.g., approximately 25-85 mm in length, approximately 5-45 mm in width, and about 2-3 mm in thickness).

As shown in the side view of **FIG. 4A**, the tibial component **40** could be curved. More specifically, the tibial component **40** could have a first proximal planar portion **42**, a first bend **44**, a second central planar portion **46**, a second bend **47** (e.g., the second bend **47** opposite in direction to the first bend **44**), and a third distal planar portion **48**. The first, second, and third planar portions **42**, **46**, and **48** include front and back general planar faces and opposing generally planar edges. At the distal edge, the edges terminate in a rounded distal edge.

The third distal planar portion **48** of the tibial component **40** contains attachment holes **48a**, **48b** and **48c** for attachment to the tibia (e.g., two to three permanent attachment holes). The diameter of these holes can be sized such that they will accept the appropriate sized screw, or other fastener (e.g., 3.5 mm in diameter for placement of a 3.5 mm cortical bone screw). The holes **48a**, **48b** and **48c** can be sized to have a sufficient diameter such that the head of the screw (e.g., 3.5 mm cortical bone screw), will fit flush with the tibial component **40**. Any sized bone screws could be used (e.g., 2.0 mm, 2.7 mm, or 3.5 mm), and the holes **48a**, **48b** and **48c** can be sized accordingly. The attachment holes can be sized such that they will accept the appropriate sized screw and so that the screw is flush

when implanted. Further, the tibial component **40** could utilize locking technology (e.g., locking screws and locking attachment holes **48a**, **48b** and **48c**).

The first planar portion **42** forms a dihedral angle (e.g., bend **44**) with the second planar portion **46**, and the second planar portion **46** forms a dihedral angle (e.g., bend **47**) with the third planar portion **48**. The proximal part of the tibial component **40**, when implanted, can be elevated (e.g., about 1-2 mm) off the medial surface of the proximal tibia (e.g., dihedral angles) to allow for the clearance of the soft tissues of the proximal stifle. The first proximal planar portion **42** of the tibial component **40** has wider edge to edge front and back generally planar faces compared with the second planar portion **46** and third planar portion **48**.

As shown in **FIG. 4B**, the first planar portion **42** could be angled (e.g., plane angle) with respect to the second planar portion **46**, whereas the second and third planar portions **46** and **48** could be aligned. Additionally, the first proximal planar portion **42** includes a slot **50** (e.g., rectangular) extending through the front and back generally planar faces. This rectangular slot **50** on the tibial component **40** receives, such as by a pressure fit attachment, the articular sliding insert component **60**. The rectangular slot **50** allows the articular sliding insert component **60** to be firmly held in place. However, any other suitable way of connecting the insert component **60** to the tibia component **40** and the femoral component **10** to the insert component **60** could be used.

FIGS. 5A-5E are perspective, top, front, side, and bottom views, respectively, of the articular sliding insert component. The articular sliding insert component **60** could be rectangular shaped, and conforms to (and pressure fits into) the slot **50** (e.g., rectangular) of the tibial component **40**. The articular sliding insert component **60** allows for the internal and external rotation at any phase of extension or flexion. The articular sliding insert component **60** could be rectangular and be made of a biocompatible, surgically implantable material that preferably has good wear characteristics, is inert and carries a low coefficient of friction. As such, the insert component could be made of a plastic such as a UHMWPE material.

The articular sliding insert component **60** (e.g., intermediate component) comprises a rectangular-shaped component that conforms to, and is received by, the rectangular opening **50** of the proximal tibial component **40**, discussed in **FIGS. 4A-4C** above. However, the opening **50** and the insert component **60** could be of any suitable shape. The articular sliding insert component **60** has a top **62**, side walls **64**, and rear wall **69**

surrounding a central channel **67** (e.g., circular), a front wall **68**, as well as lower angled flange extensions **66** extending outwardly from the lower portion of sidewalls **64**, and upper shoulder extensions **63**. More specifically, the underside of the articular sliding insert component **60** has an angled/bevelled flange **66** extending outward.

The insert component **60** could be inserted in slot **50** of tibial component **40**, and then secured therein by shoulders **63**, and flanges **66**. The insert **60** could be secured in the tibial component **40** by a pressure fit or otherwise. When assembled, the insert component **60** can be maintained in position with respect to the tibial component by virtue of the tibial component fitting between the lower flanges **66** of the insert component **60** and corresponding shoulders **63** positioned in facing relationship thereto. The flanges **66** could be level with the edge of the tibial component **40**. The flanges **66** provide continual separation of both the tibial and femoral components. This extension can be angled/bevelled to allow and limit internal and external rotation (e.g., ten degrees) of the tibial component **40** relative to the femoral component **10**. The relative rotation could be limited to approximately ten (10) degrees of internal rotation and ten (10) degrees of external rotation by the angled flanges **66**.

As shown in **FIG. 5C**, the central channel **67** (e.g., cavity) is cylindrically shaped, and could extend through one or both of the forward and rear walls **68** and **69**. Further, the channel could extend through the bottom of the insert component **60** thereby providing enough room to provide lateral movement for the stem **22**, but insufficient room for the ball **20** to detach from the insert component **60**. The channel **67** could extend through the forward side **68** for at least a portion toward the rear wall **69**. In other words, one end of the insert **60** could have a rear wall **69** that closes one end of the channel **67** (or the channel could extend through the rear wall **69**).

The articular central channel **67** of sliding insert component **60** is configured to accept and interlock (e.g., correspond in size and shape) with the spherical ball **20** attached to the femoral component **10**, discussed in **FIGS. 3A-3G** above. As such, the connection between the cylindrical channel **67** and the ball **20** creates a ball and socket type joint that allows for rotational and pivotal/swivel movement of the ball **20** with respect to the channel **67**, and accordingly, allows for such movement of the femur with respect to the insert component **60** and the tibial component. Further, the channel **67** allows for the ball to slide from the forward end **68** to the rear end **69** (e.g., along the length of the channel) thereby providing for additional translational movement of the ball **20** with respect to the

channel **67**, and accordingly, allows for such movement of the femoral component with respect to the insert component **60** and the tibial component. The ball **20** is able to rotate within and slide along the channel **67** after implantation permitting normal joint movement but preventing abnormal tibial thrust. This allows the femoral ball **20** to be captured and held in place during all phases of the stride. When the insert **60** is attached to the tibial component, the slot **50** could close off one (or both) ends of the cavity **67** to prevent the ball from escaping the cavity **67**.

FIGS. 6A-6C show views of the ball **20** and stem **22** that connects with the femoral component **10** and the articular sliding component **60**, as discussed above. Like the femoral and tibial components, the ball **20** and stem **22** can be made of a biocompatible material. The ball **20** engages the articular sliding insert component **60**, described in **FIGS. 5A-5E** above, which is in turn inserted into the tibial component. This forms the articulation point on the femoral component.

FIGS. 7-10 are perspective views showing the assembly of the system. **FIG. 7** is a perspective view showing the insert component **60** positioned to slide over and engage with ball **20** attached to femoral component **10**. **FIG. 8** is a perspective view showing the ball **20** attached to the femoral component **10** engaged within the insert component **60**. **FIG. 9** is a perspective view of the tibial component **40a** positioned to receive the insert component **60** into rectangular slot **50**. Tibial component **40a** is like tibial component **40** of **FIGS. 4A-4C**, but with rounded corners. **FIG. 10** is a perspective view showing the fully engaged device.

FIG. 11 is a perspective view of another aspect of the assembled system, and **FIG. 12** is a side view of the apparatus of **FIG. 11** fully assembled. As with the aspect described above, the system includes a femoral component **110**, a tibial component **140**, and an articular sliding insert component **160**. The system shown in **FIG. 11** is configured and functions in the same manner as the system shown in **FIGS. 1-10** except as discussed, and like elements are given like reference numerals, plus 100.

FIGS. 13A-13C are perspective, rear, and side views of the femoral component **110** of **FIG. 11**. Similar to the femoral component shown in **FIGS. 3A-2G**, femoral component **110** includes a leg portion **112** and a bottom portion **114**, but also includes an intermediate portion **113**. The leg portion **112** and bottom portion **114** each form plane angles (e.g., in the same direction) with respect to the intermediate portion **113** therebetween, thereby forming a general hockey stick shape. The femoral component **110**

could have a dihedral angle (e.g., first bend **117**) between the leg portion **112** and intermediate portion **113**, and a dihedral angle (e.g., second bend **119**) between the intermediate portion **113** and the bottom portion **114**. The first bend **117** and second bend **119** being in the same direction.

The femoral component **110** contains attachment holes **112a**, **112b**, and **112c** in leg **112** and an aperture in bottom portion **114**. The femoral component **110** could further comprise a ball **120** and stem **122** in bottom portion **114** of the femoral component **110**. The stem **122** is received by aperture **116**, and the ball **120** extends outward from the outer surface of the bottom portion **114** of the femoral component **110** at approximately 90 degrees. The femoral component **110** further comprises one or more temporary attachment holes **121**. The temporary attachment holes **121** could be used for temporary fixation with a surgical tool or temporary surgical implant (e.g., holding pins, k-wire, etc.). Further, the femoral component **110** could utilize locking technology (e.g., locking screws and locking attachment holes **112a**, **112b** and **112c**).

FIG. 14 is a perspective view of the tibial component **140** of **FIG. 11**. The tibial component **140** could have a first proximal planar portion **142**, a first bend **144**, a second central planar portion **146**, a second bend **147** (e.g., the bend opposite in direction to the first bend), and a third distal planar portion **148**. The first, second, and third planar portions **142**, **146**, and **148** include front and back general planar faces and opposing generally planar edges. The third distal planar portion **148** of the tibial component **140** contains attachment holes **148a**, **148b** and **148c** for attachment to the tibia (e.g., two to three permanent holes). The tibial component **140** further comprises one or more temporary attachment holes **123**. The temporary attachment holes **123** could be used for temporary fixation with a surgical tool or temporary surgical implant (e.g., holding pins, k-wire, etc.). Further, the tibial component **140** could utilize locking technology (e.g., locking screws and locking attachment holes **148a**, **148b** and **148c**).

The first proximal planar portion **142** could be angled (e.g., plane angle) with respect to the second proximal planar portion **146**, whereas the second and third proximal planar portions **146** and **148** could be aligned. The first planar portion **142** forms a dihedral angle (e.g., bend **144**) with the second planar portion **146**, and the second planar portion **146** forms a dihedral angle (e.g., bend **147**) with the third planar portion **148**.

The first proximal planar portion **142** includes a slot **150** (e.g., rectangular) extending through the front and back generally planar faces. This rectangular slot **150** on

the tibial component **140** receives, such as by a pressure fit attachment, the articular sliding insert component **160**. The rectangular slot **150** allows the articular sliding insert component **160** to be firmly held in place. The slot **150** further includes a niche **151** (e.g., keyhole) at a distal end of the slot **150** of general corresponding shape and size to ball **120** of femoral component **110**. The niche **151** allows the articular sliding component **160** to be inserted (e.g., pressure fit) into the slot **150** of the tibial component **140** prior to attachment of the ball **120** of the femoral component **110**. In this way, the niche **151** allows the ball **120** of the femoral component **110** to engage the channel of the articular sliding insert component **160** when fixed in place in the tibial component **140**, thereby allowing the ball **120** to be captured and held in place during all phases of the stride. This allows for greater flexibility in assembling the system.

FIG. 15 is a perspective view of the articular sliding insert component **160** of **FIG. 11**. The articular sliding insert component **160** comprises a rectangular-shaped component that conforms to, and is received by, the rectangular opening **150** of the proximal tibial component **140**, discussed in **FIGS. 3A-3C** and **21** above. The articular sliding insert component **160** has a top **162**, side walls **164**, and rear wall **169** surrounding a central channel (e.g., circular), a front wall **168**, as well as lower angled flange extensions **166** extending outwardly from the lower portion of sidewalls **164**, and upper shoulder extensions **163**.

The insert component **160** could be inserted in slot **150** of tibial component **140**, and then secured therein by shoulders **163**, and flanges **166**. The central channel **167** is cylindrically shaped, and could extend through one or both of the forward and rear walls **168** and **169**. Further, the channel could extend through the bottom of the insert component **160** thereby providing enough room to provide lateral movement for the stem **122**, but insufficient room for the ball **120** to detach from the insert component **160**. The channel **167** could extend through the forward side **168** for at least a portion toward the rear wall **169**. In other words, one end of the insert **160** could have a rear wall **169** that closes one end of the cavity **167** (or the channel could extend through the rear wall **169**).

The components of the apparatus, such as the femoral and tibial components, or plates, can be either machined from a solid piece of material or they can be stamped using a stamping tool and then finished with machining operations, as is known in the art. Similarly, the insert component can be created by molding and/or machining.

While the components of the apparatus could be sold separately and assembled by a user such as a surgeon, the apparatus will generally be sold preassembled as a unit. The preassembled apparatus will be installed in an animal by attaching the femoral plate and tibial plate, respectively, to the femur and tibia of an animal.

FIGS. 16-17 are partial perspective views of another aspect of the apparatus fully assembled. As with the aspect described above, the system includes a femoral component **210**, a tibial component **240**, and an articular sliding insert component **260**. The system shown in **FIGS. 16-17** are configured and function in the same manner as the system shown in **FIGS. 1-15** except as discussed, and like elements are given like reference numerals, plus 100.

Chronic stifle instability can lead to debilitating end stage stifle disease. This disease process is characterized by severe joint thickening and loss of articular cartilage with bone on bone contact, which occurs primarily in the medial compartment of the quadruped stifle. The stifle stabilization system of the present disclosure could further include a weight reduction spring **290** to reduce the weight placed on the medial compartment of the quadruped stifle and thereby reducing the pain associated with end stage stifle disease. The spring **290** (e.g., compression spring) could be inserted into the sliding articulation channel **250** after the tibial component **240** has interconnected with the femoral component **210**. The spring can be held in place with a spring retaining device **292** (e.g., locking button). The spring retaining device **292** could be assembled in the niche **251** of the slot **250** of the tibial component **240** (and could extend above and below the surface of the tibial component **240**).

FIG. 17 is a partial view of **FIG. 16** with the articular sliding component **260** removed. In this way, the spring **290** is located between a stem **222** of the femoral component **210** and the spring retaining device **292** of the tibial component **240**. The spring **290** could come in a variety of strengths correlating to the size of the quadruped.

Having thus described the system and method in detail, it is to be understood that the foregoing description is not intended to limit the spirit or scope thereof. It will be understood that the embodiments of the present disclosure described herein are merely exemplary and that a person skilled in the art may make any variations and modification without departing from the spirit and scope of the disclosure. All such variations and

modifications, including those discussed above, are intended to be included within the scope of the disclosure.

CLAIMS

1. A stifle stabilization system, comprising:
 - a femoral component (10) having an interconnected coupling member (20) protruding therefrom;
 - an articular sliding insert component (60) defining a cylindrical channel corresponding in size and shape to at least part of the coupling member; and
 - a tibial component (40) defining a slot, the slot (50, 150) being of corresponding and complementary shape to sidewalls (64) of the articular sliding insert component to receive the articular sliding insert component therein in a pressure fit engagement,wherein, when the channel receives the at least part of the coupling member and the articular sliding insert component is received in the slot of the tibial component, the tibial component is interlocked with the femoral component with translational and rotational movement therebetween.
2. The system of claim 1, wherein the femoral component includes a leg portion (12) and a bottom portion (14), and wherein the bottom portion includes the interconnected coupling member, and the tibial component has a first proximal planar portion (42) defining the slot.
3. The system according to claim 2, wherein the leg portion and the bottom portion form a plane angle with respect to one another.
4. The system according to claim 2, wherein the leg portion and the bottom portion form a dihedral angle with respect to one another.
5. The system according to claim 2, wherein the leg portion and the bottom portion form plane angles with respect to an intermediate portion therebetween.
6. The system according to claim 2, wherein the leg portion and the bottom portion form dihedral angles with respect to an intermediate portion therebetween.
7. The system according to any one of claims 2-6, wherein the coupling member comprises a ball (20) and stem (22), and wherein the bottom portion of the femoral

component includes an aperture (16), and the stem is retained within the aperture.

8. The system according to any one of claims 1-2, wherein the femoral component has one or more attachment holes (12a, 12b, 12c), and the tibial component has one or more attachment holes (48a, 48b, 48c).

9. The system according to any one of claims 1, 2, and 8, wherein the system, when surgically implanted, stabilizes an unstable quadruped stifle joint during all phases of a stride and allows for normal stifle flexion, extension, internal rotation, external rotation, joint compression, and varus and valgus movement.

10. The system according to any one of claims 1, 2, 8 and 9 wherein the femoral component is configured to conform to contours of a femur, and the tibial component is configured to conform to contours of a tibia.

11. The system according to any one of claims 1-10, wherein the slot (150) further defines a recess (151) corresponding in size and shape to the at least part of the coupling member of the femoral component.

12. The system according to claim 7, wherein when the channel receives the ball of the coupling member and the articular sliding insert component is received in the slot of the tibial component, the tibial component closes an end of the channel to retain the ball in the channel, and wherein the ball of the femoral component is slidable along a length of the channel of the articular sliding component when the ball is retained in the channel.

13. The system according to any one of claims 1-12, wherein the tibial component has a first proximal planar portion (42) and a third distal planar portion (48) that form dihedral angles with respect to a second central planar portion (46) therebetween.

14. The system of claim 13, wherein the first proximal planar portion is angled with respect to the second proximal planar portion, and the second and third proximal planar portions are aligned.

15. The system according to any one of claims 1-14, wherein the articular sliding insert component further comprises a lower angled flange extensions protruding outwardly

from a lower portion of the sidewalls, and an upper shoulder extensions, wherein when the tibial component is inserted into the slot of the tibial component, the tibial component is secured between the flange extensions and shoulder extensions of the articular sliding insert component.

16. A stifle stabilization system, comprising:

a femoral component having a leg portion and bottom portion, the bottom portion including an interconnected coupling member protruding therefrom;

an articular sliding insert component defining a channel corresponding in size and shape to at least part of the coupling member; and

a tibial component having a first proximal planar portion defining a slot, the slot being of corresponding and complementary shape to the articular sliding insert component to receive the articular sliding insert component therein;

wherein, when the channel receives the at least part of the coupling member and the articular sliding insert component is received in the slot of the tibial component, the tibial component is interlocked with the femoral component with translational and rotational movement therebetween; and

wherein the bottom portion of the femoral component includes an aperture and the coupling member is pressure fit into the aperture.

17. The system of claim 16, wherein the system, when surgically implanted, stabilizes an unstable quadruped stifle joint during all phases of a stride and allows for normal stifle flexion, extension, internal rotation, external rotation, joint compression, and varus and valgus movement.

18. The system of claim 16, wherein the leg portion of the femoral component includes attachment holes for attachment to a femur.

19. The system of claim 16, wherein the femoral component is configured to conform and to be permanently attached to a contour of a medial third of a distal femur.

20. The system of claim 16, wherein the femoral component is configured to conform

and to be temporarily attached to a contour of a medial third of a distal femur.

21. The system of claim 16, wherein the leg portion and bottom portion form a plane angle with respect to one another.

22. The system of claim 16, wherein the leg portion and bottom portion form a dihedral angle with respect to one another.

23. The system of claim 16, wherein the leg portion and bottom portion form plane angles with respect to an intermediate portion therebetween.

24. The system of claim 16, wherein the leg portion and bottom portion form dihedral angles with respect to an intermediate portion therebetween.

25. The system of claim 16, wherein the slot further defines a recess corresponding in size and shape to the at least part of the coupling member of the femoral component.

26. The system of claim 16, wherein the coupling member comprises a ball and stem.

27. The system of claim 16, wherein the tibial component is configured to conform and to be attached to a proximal medial tibia.

28. The system of claim 16, wherein the tibial component has a first proximal planar portion and a third distal planar portion that form dihedral angles with respect to a second central planar portion therebetween.

29. The system of claim 28, wherein the first proximal planar portion is angled with respect to the second proximal planar portion, and the second and third proximal planar portions are aligned.

30. The system of claim 28, wherein the third distal planar portion of the tibial component contains attachment holes for attachment to a tibia.

31. The system of claim 16, wherein the articular sliding insert component further comprises a lower angled flange extensions protruding outwardly from the lower portion of sidewalls, and an upper shoulder extensions, wherein when the tibial component is inserted into the slot of the tibial component, the tibial component is secured between the flange

extensions and shoulder extensions of the articular sliding insert component.

32. A stifle stabilization system, comprising:

a femoral component having one or more attachment holes and an interconnected coupling member protruding therefrom;

an articular sliding insert component defining a channel corresponding in size and shape to at least part of the coupling member; and

a tibial component having one or more attachment holes and defining a slot, the slot being of corresponding and complementary shape to the articular sliding insert component to receive the articular sliding insert component therein,

wherein the femoral component includes an aperture and the coupling member is pressure fit into the aperture.

33. The system of claim 32, wherein the femoral component is configured to conform to contours of a femur.

34. The system of claim 32, wherein the tibial component is configured to conform to contours of a tibia.

35. The system of claim 32, wherein the slot further defines a recess corresponding in size and shape to the at least part of the coupling member of the femoral component.

36. The system of claim 32, wherein the coupling member comprises a ball and stem.

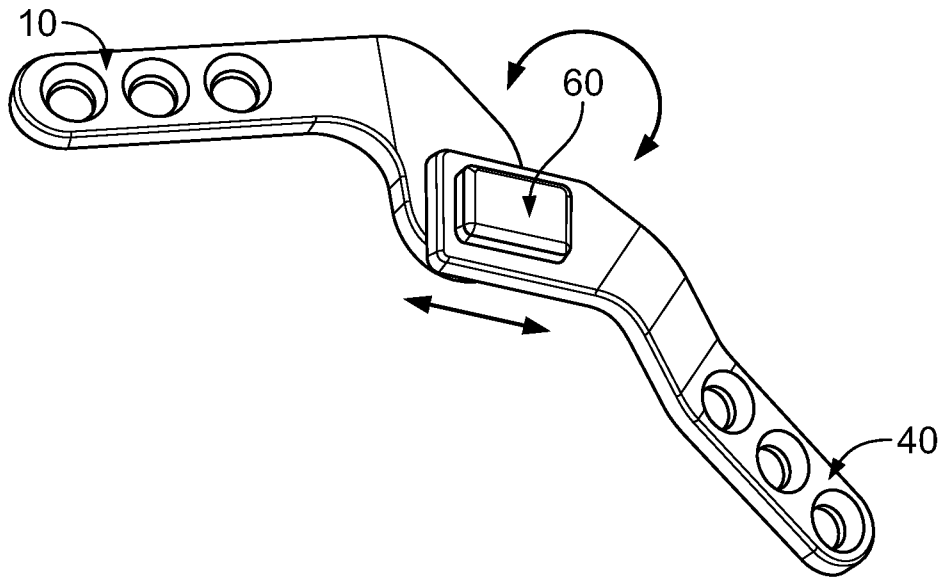

FIG. 1

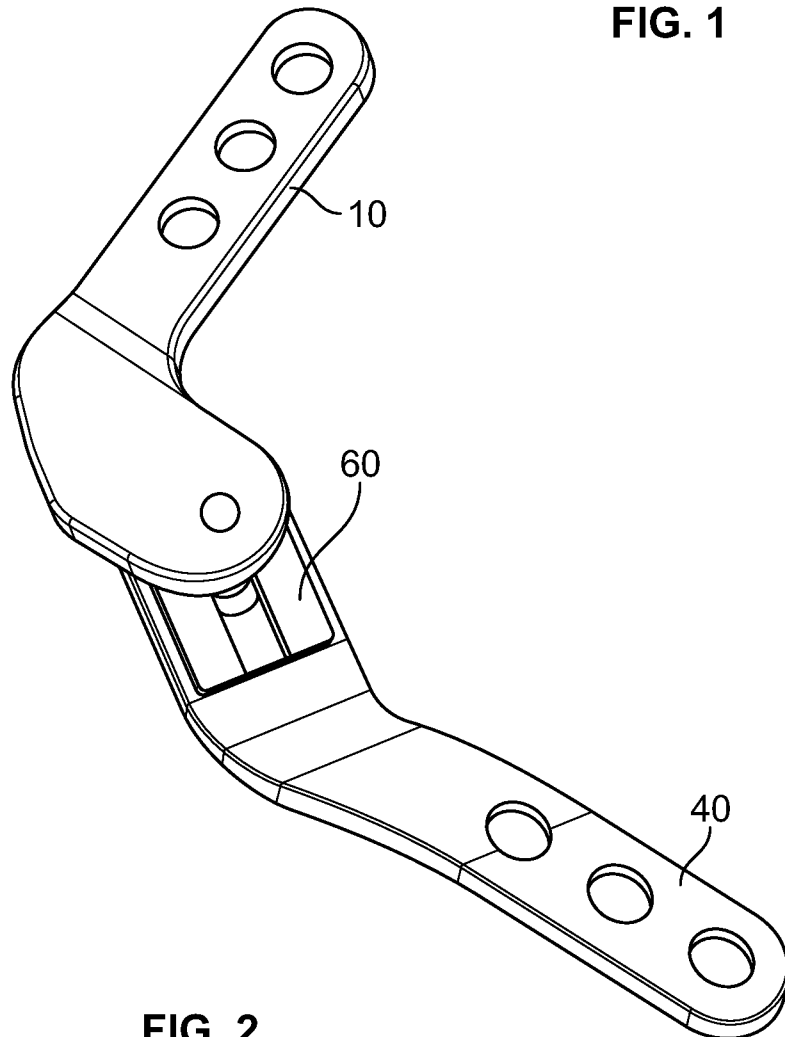

FIG. 2

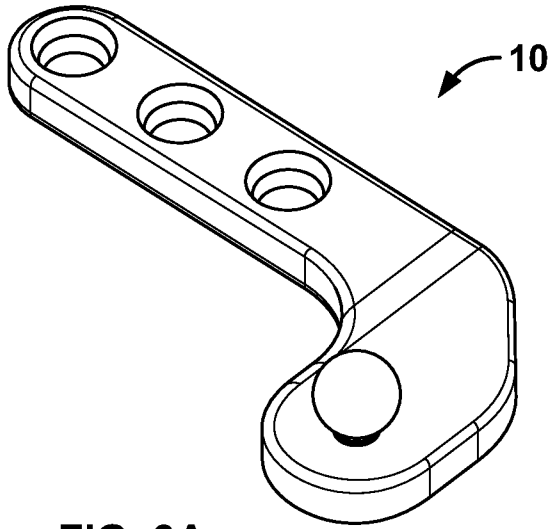

FIG. 3A

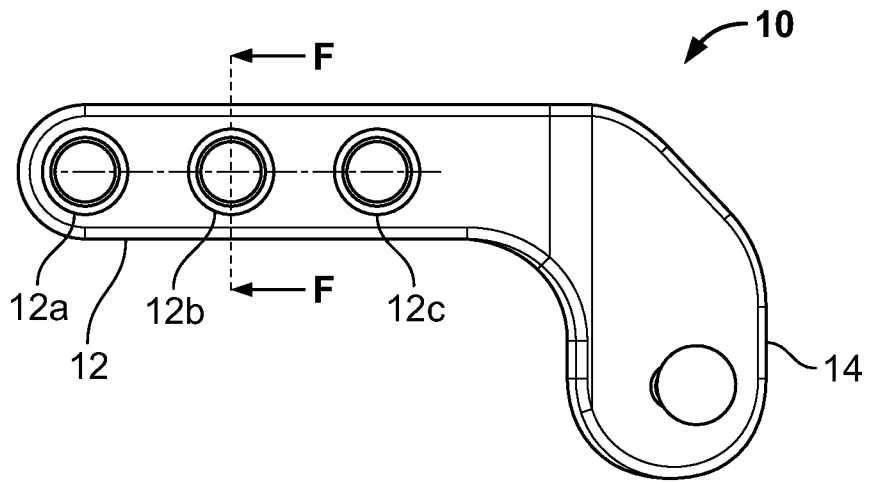

FIG. 3B

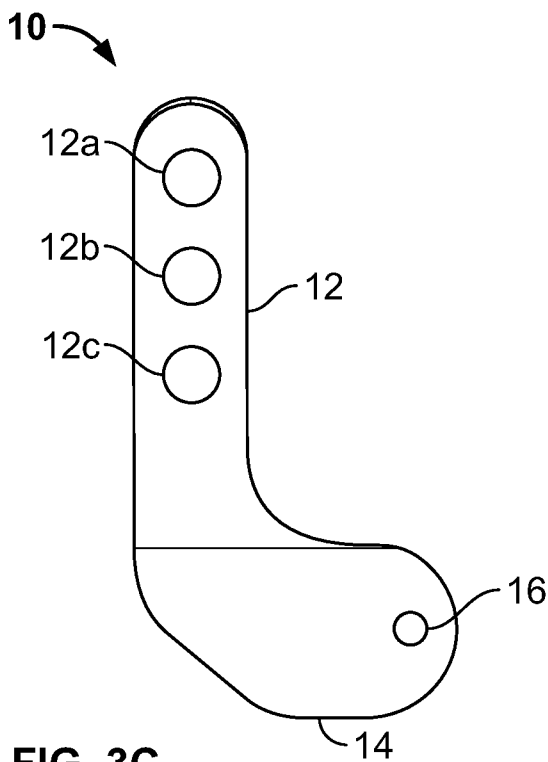

FIG. 3C

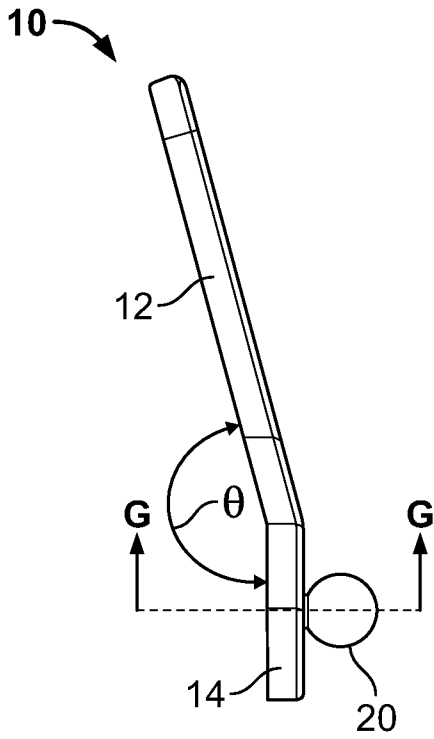

FIG. 3D

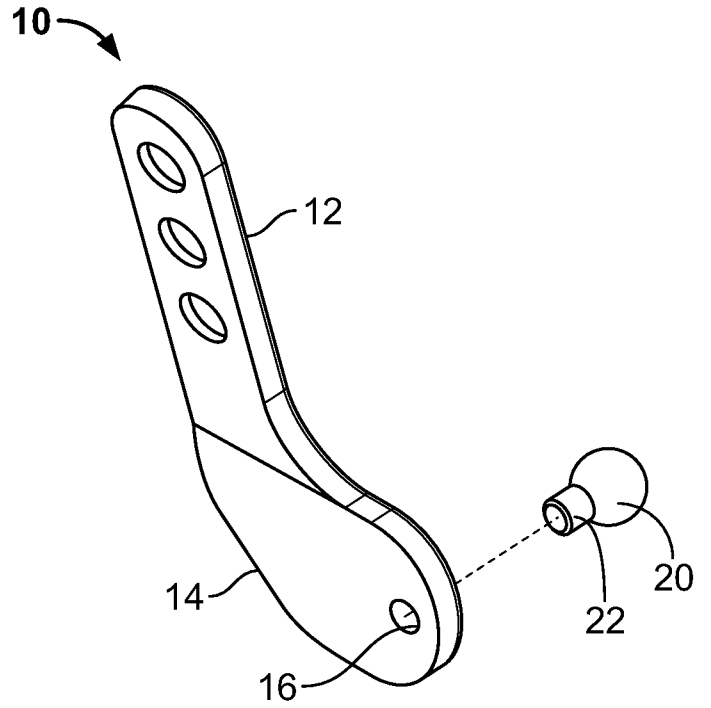

FIG. 3E

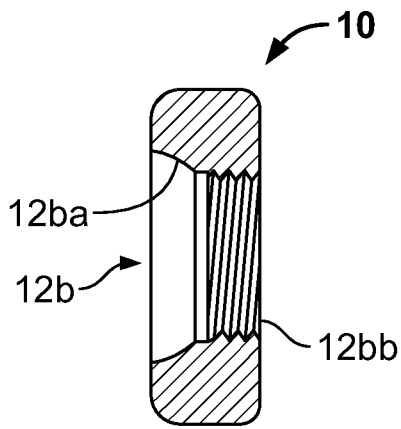

FIG. 3F

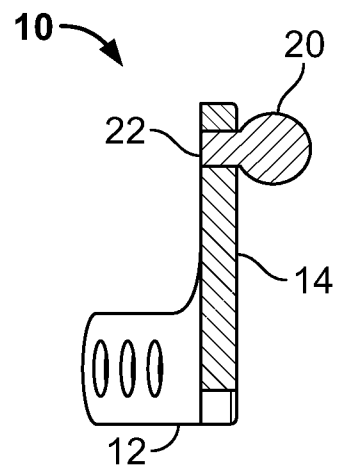

FIG. 3G

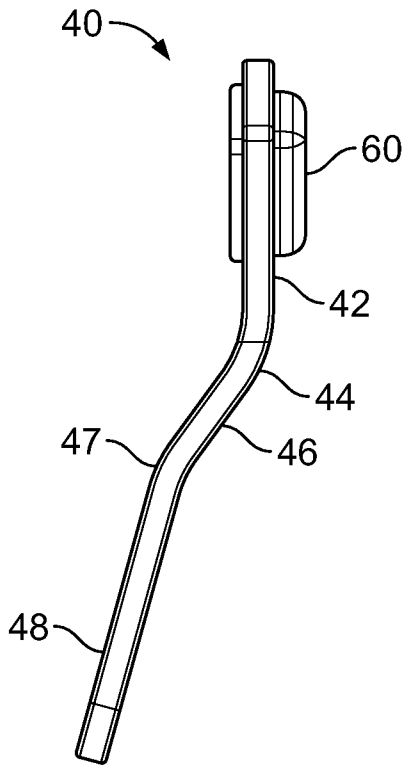

FIG. 4A

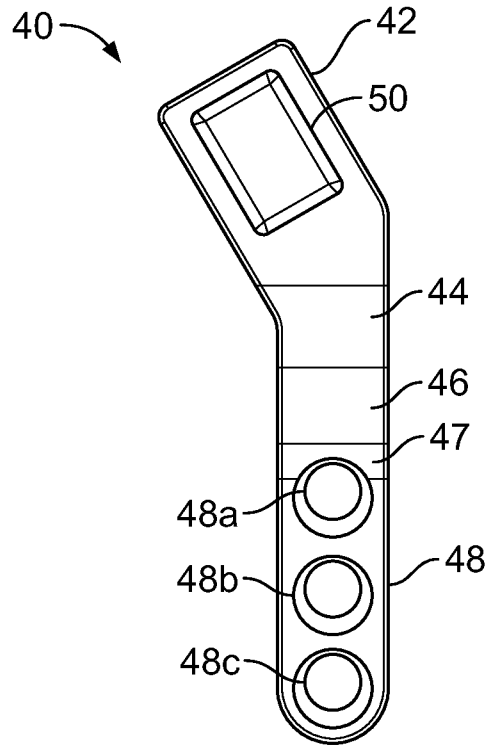

FIG. 4B

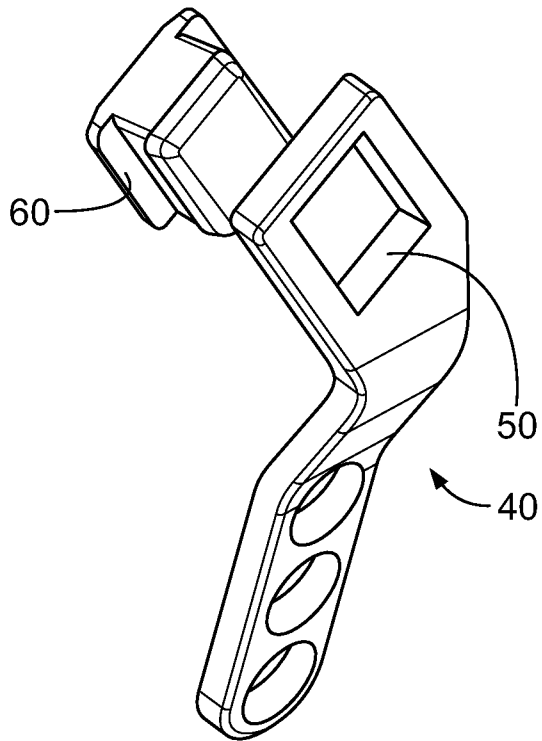
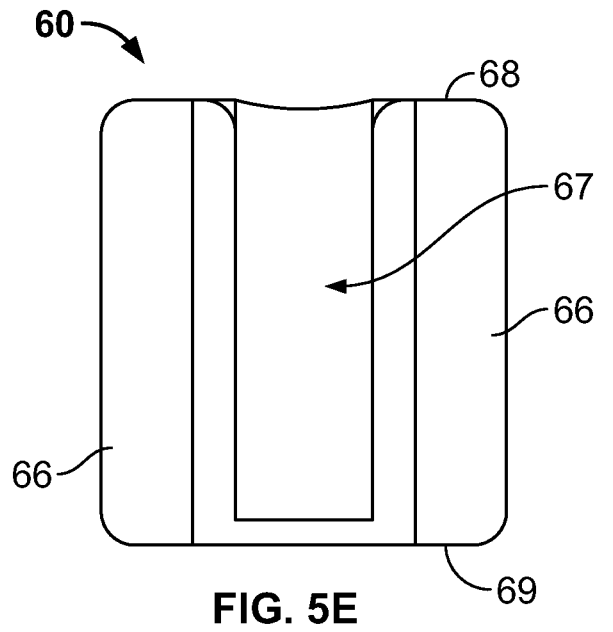
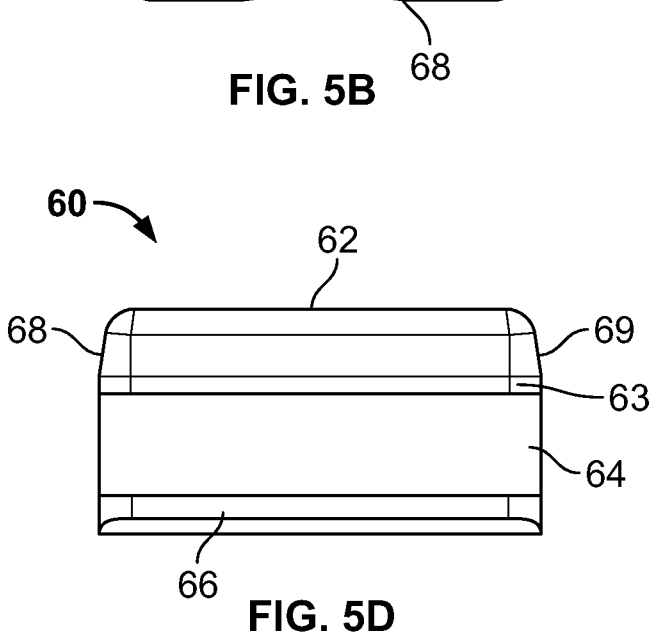
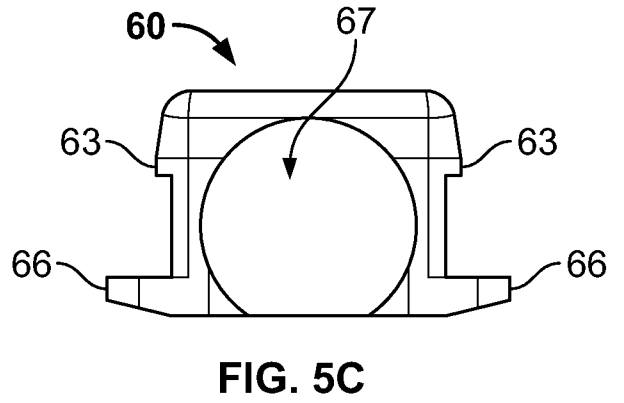
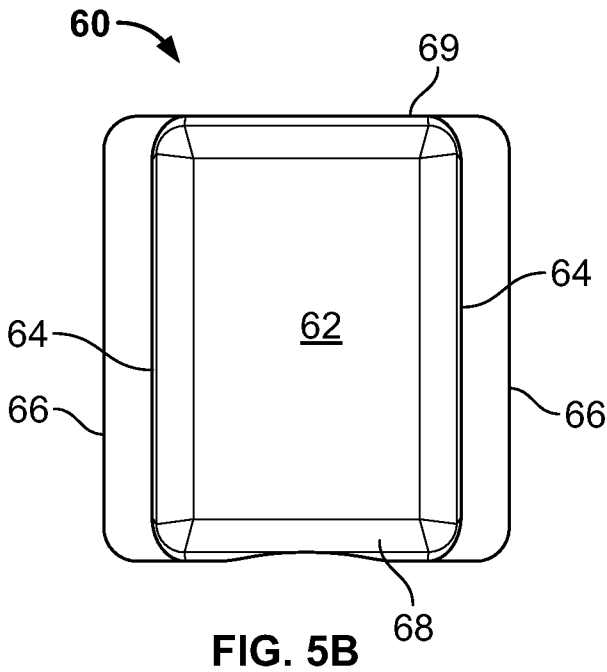
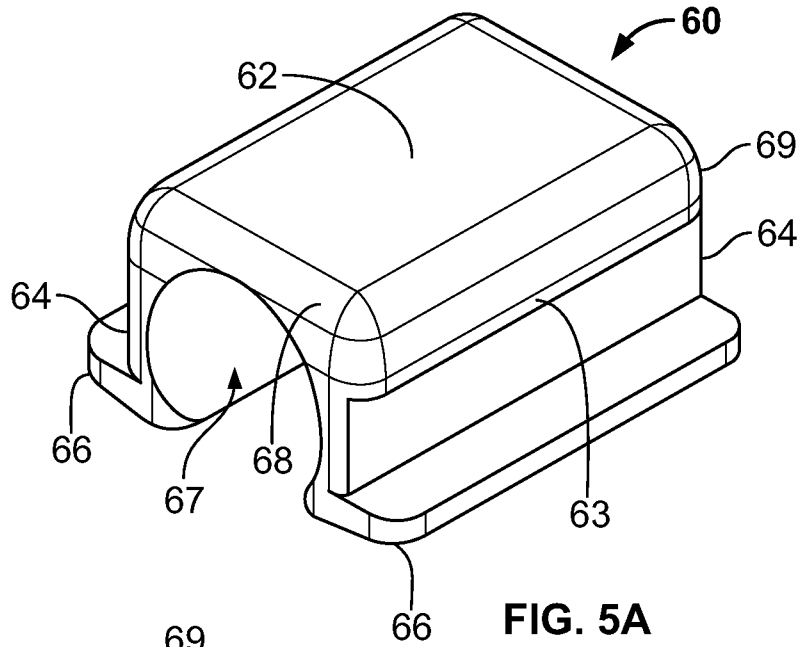

FIG. 4C



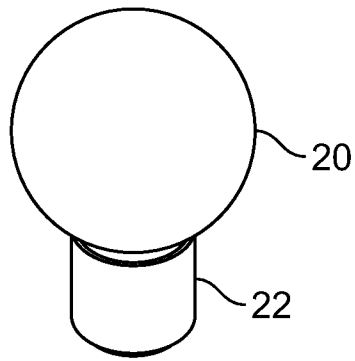

FIG. 6A

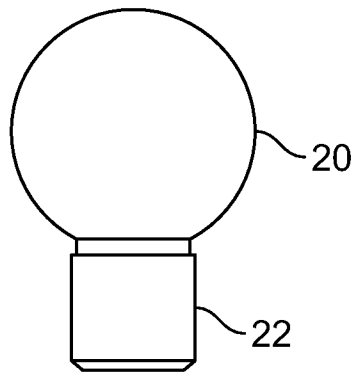

FIG. 6B

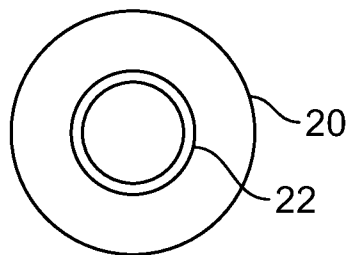

FIG. 6C

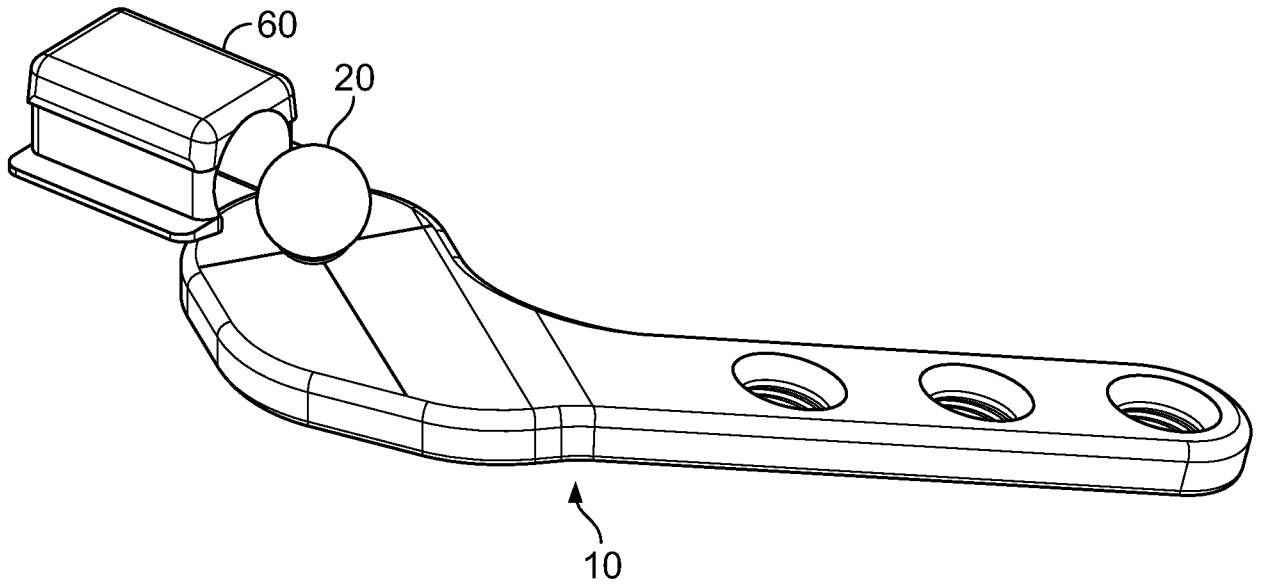

FIG. 7

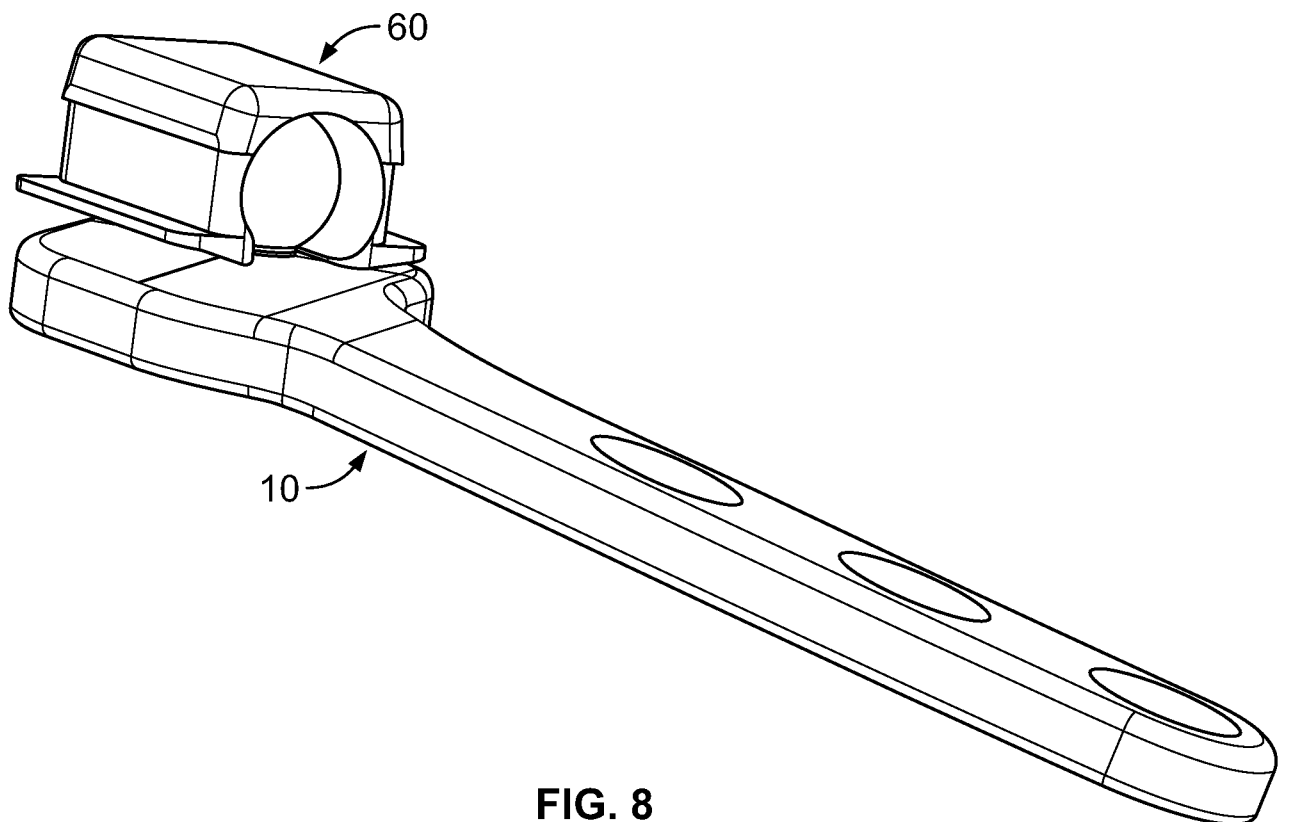

FIG. 8

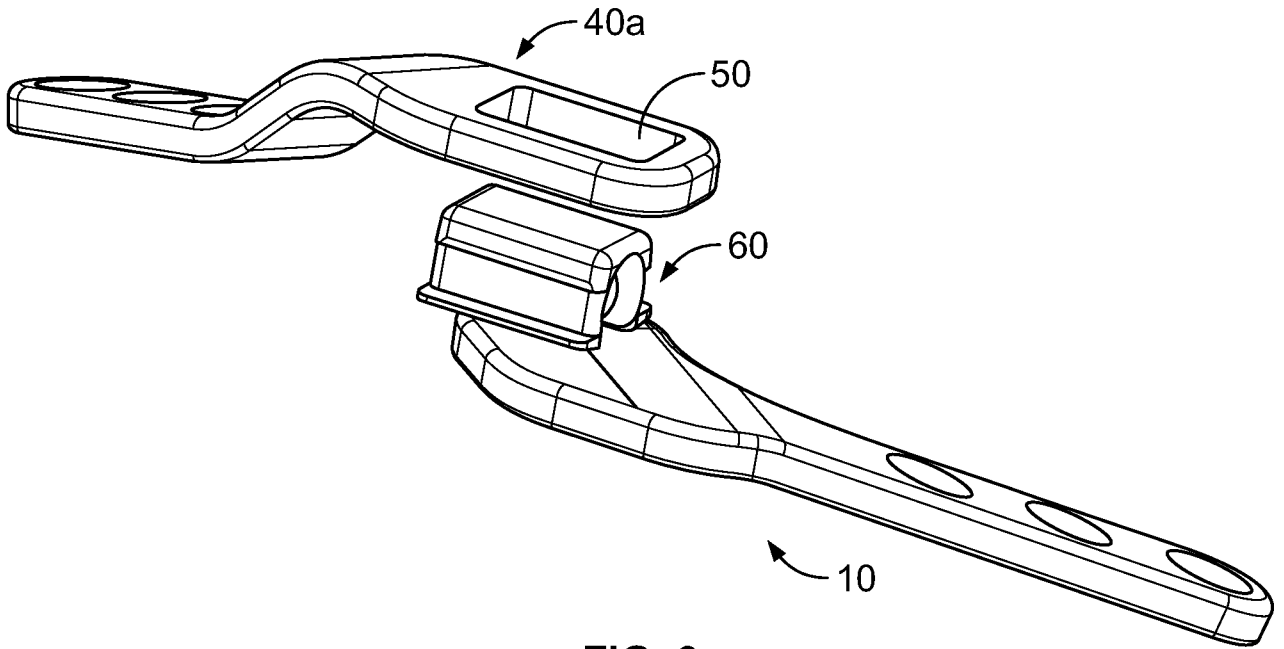

FIG. 9

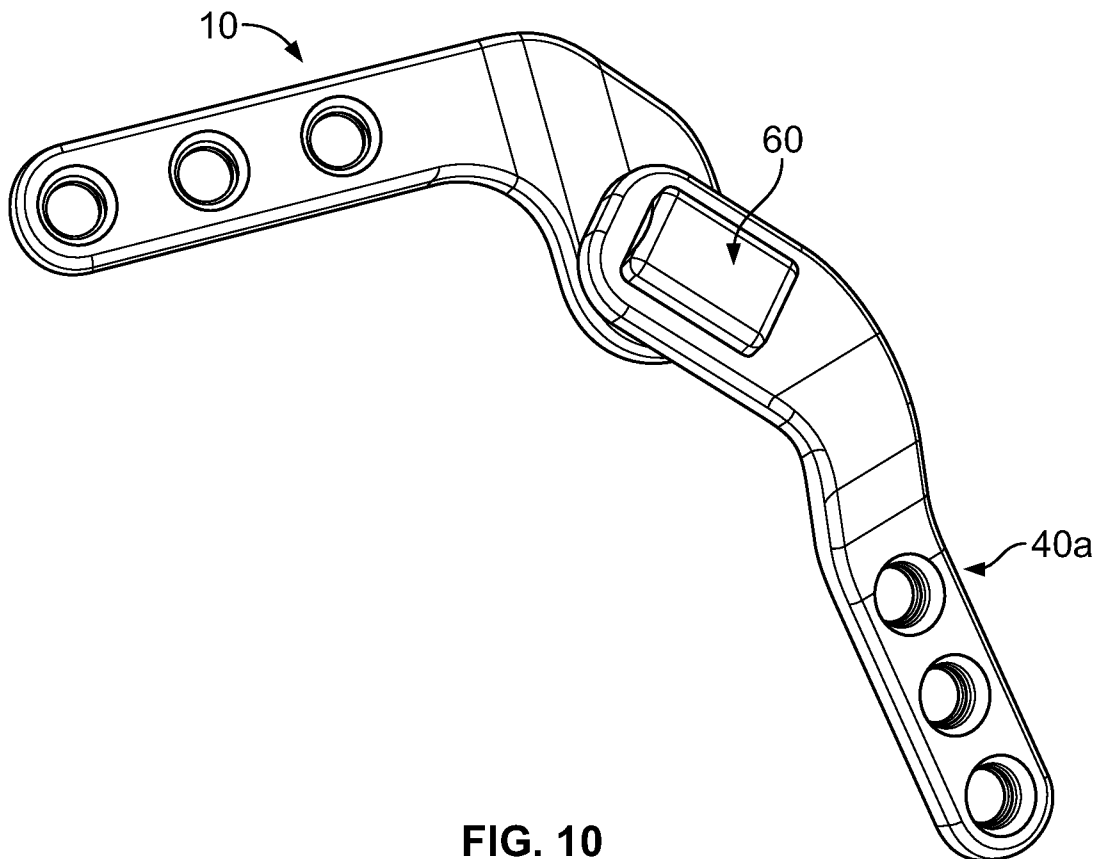

FIG. 10

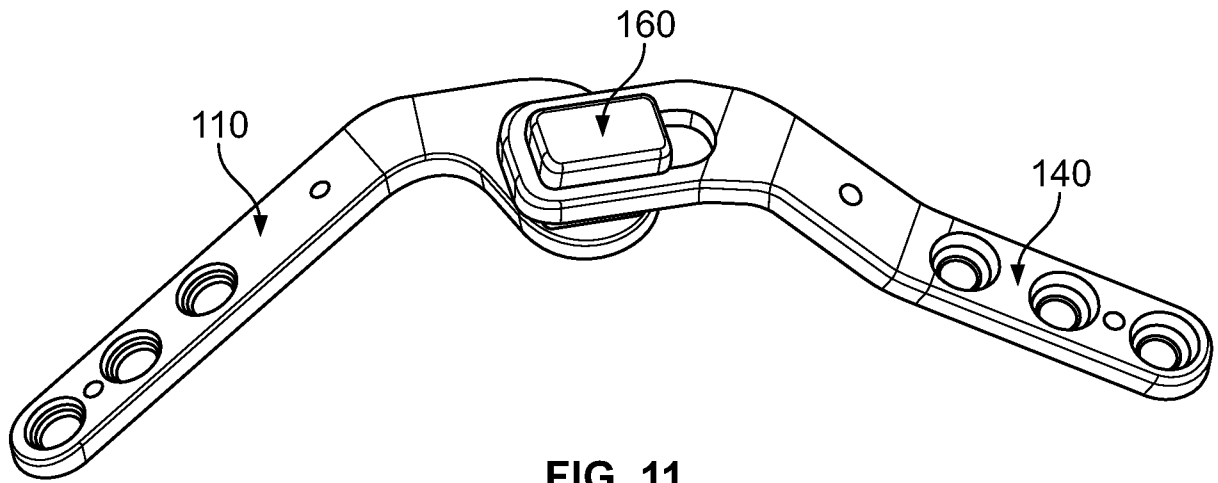

FIG. 11

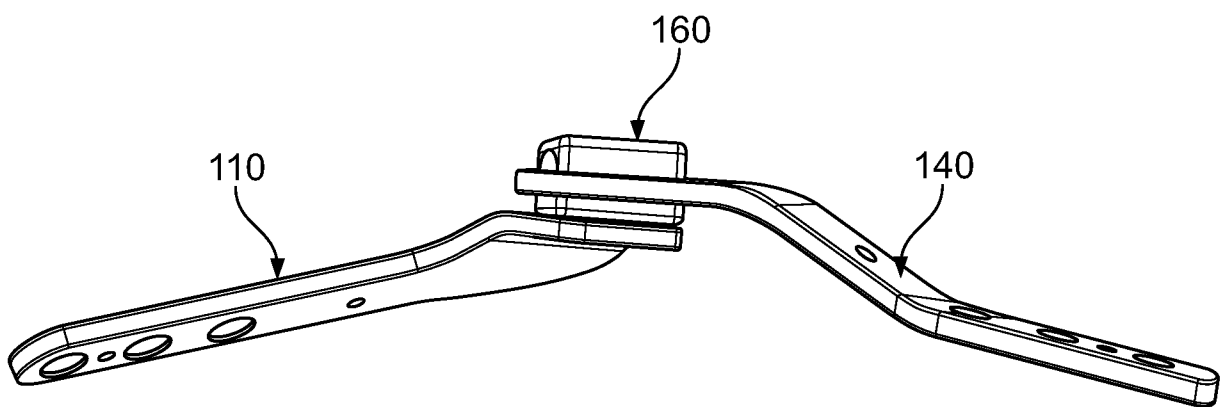

FIG. 12

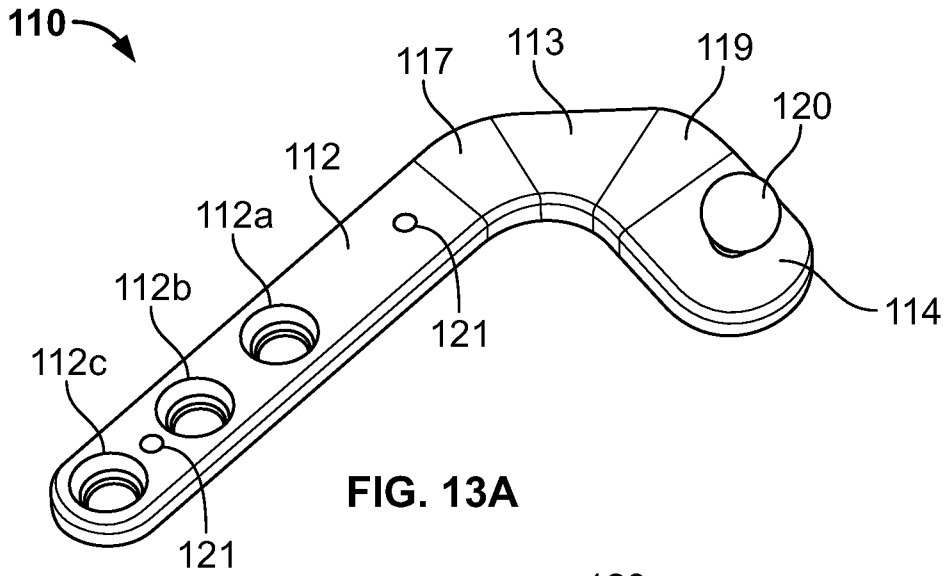

FIG. 13A

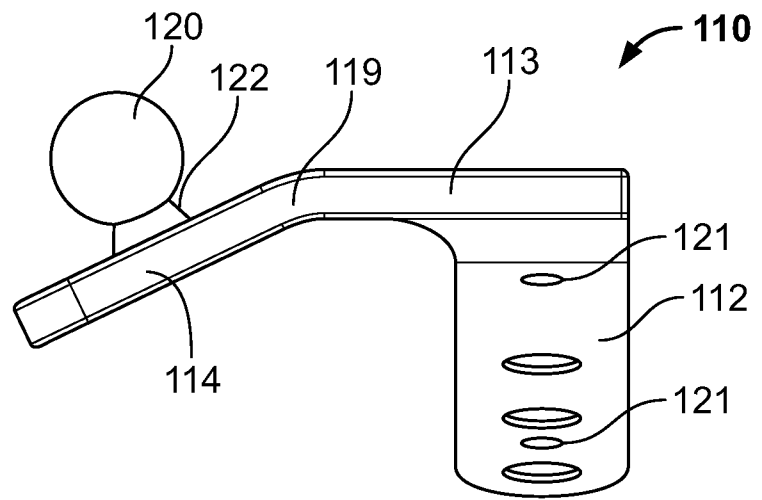

FIG. 13B

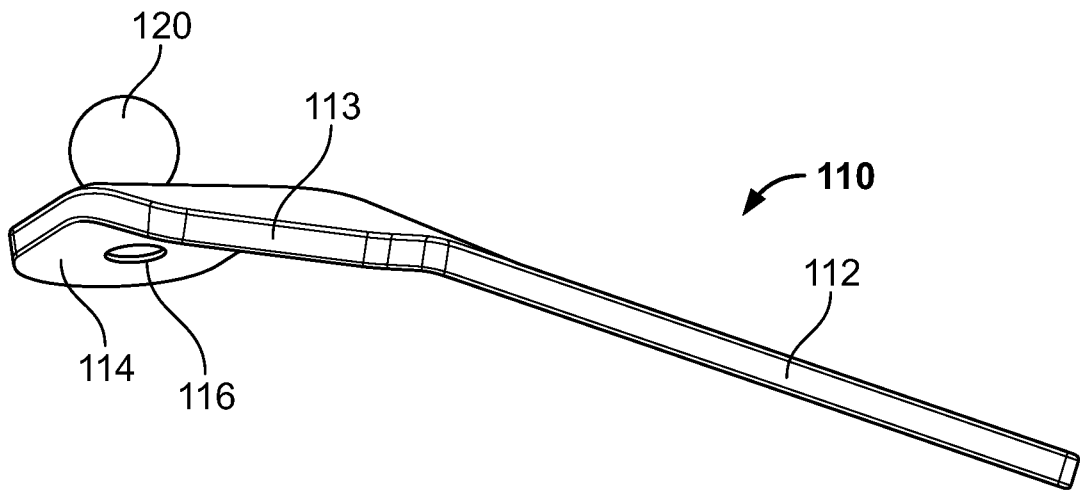
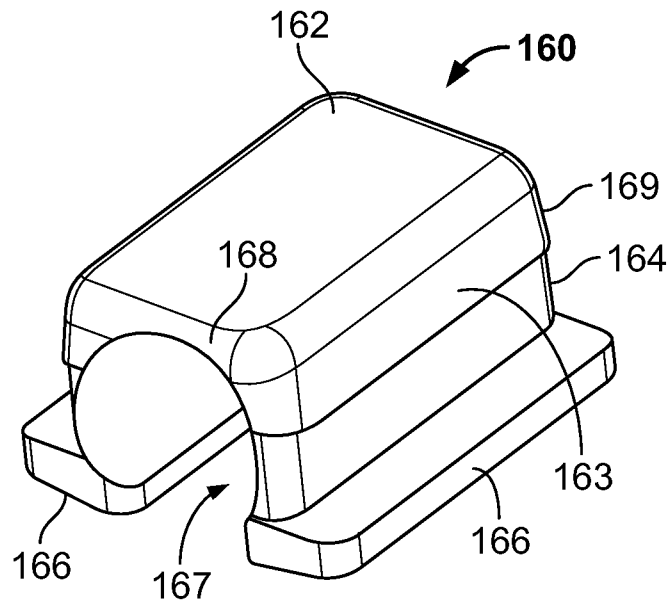
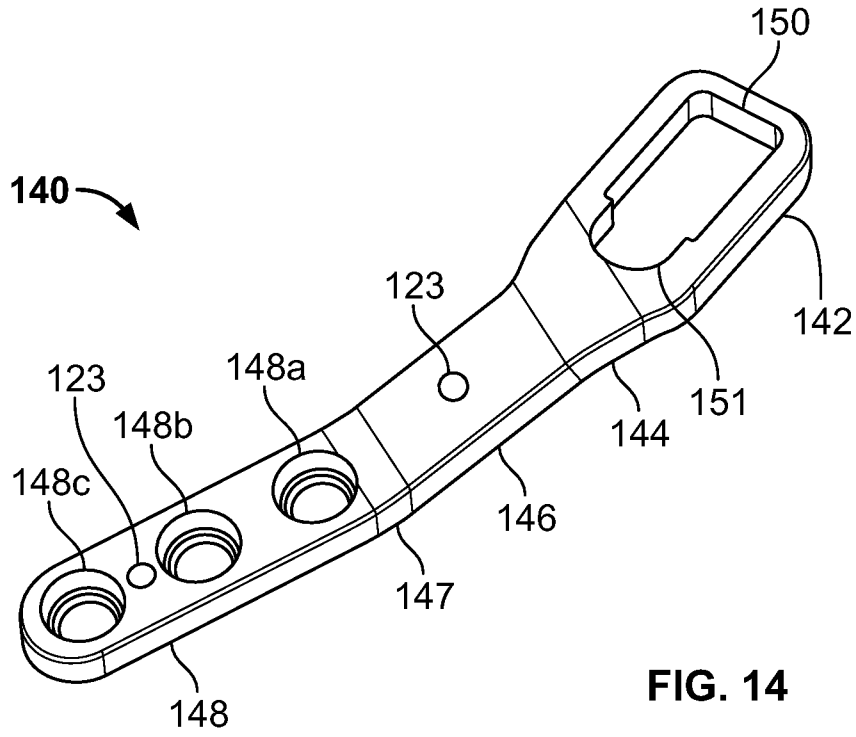

FIG. 13C



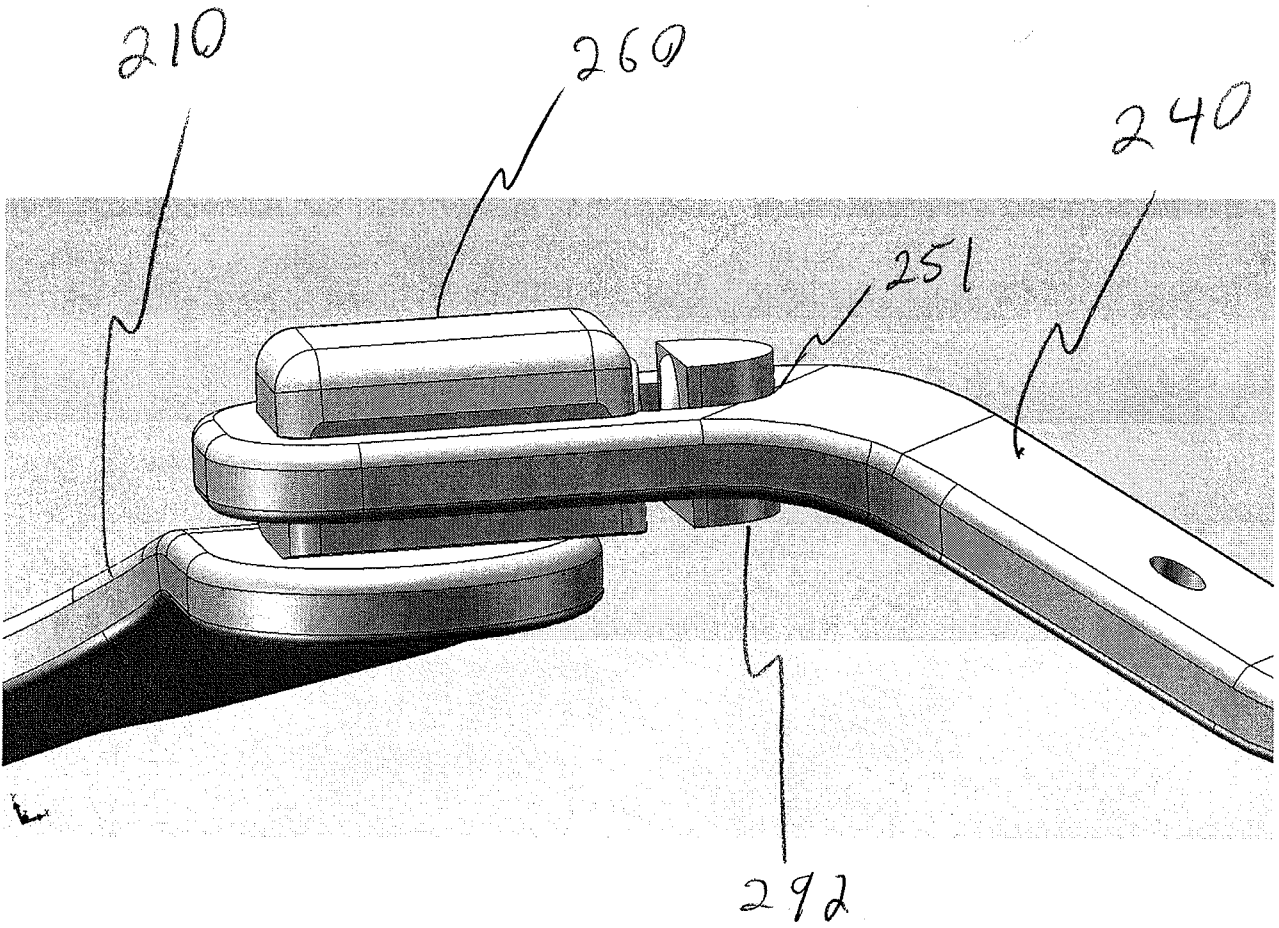

FIG. 16

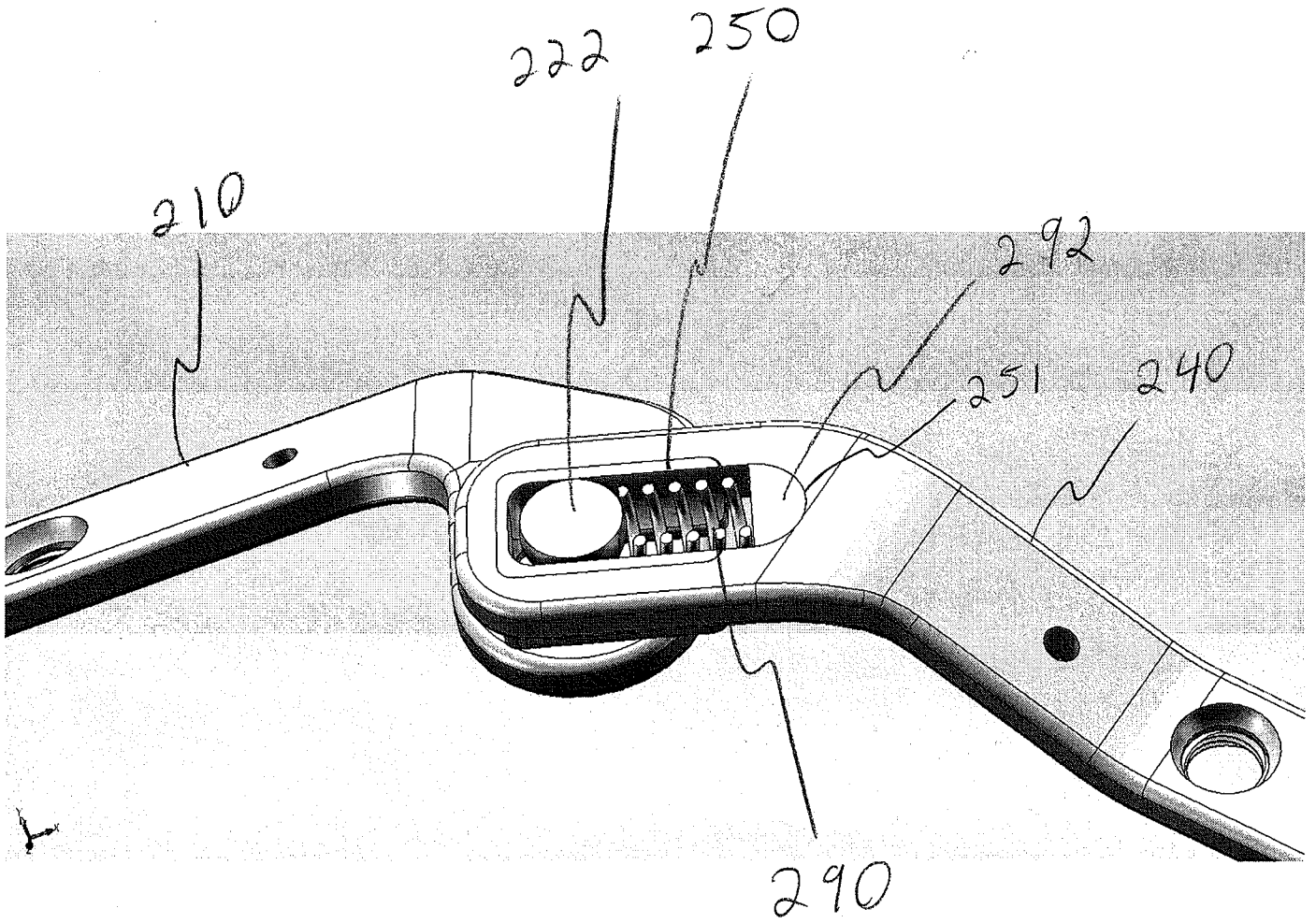

FIG. 17

