



INTERNATIONAL APPLICATION PUBLISHED UNDER THE PATENT COOPERATION TREATY (PCT)

<p>(51) International Patent Classification ⁶ : G01N 33/53</p>	<p>A2</p>	<p>(11) International Publication Number: WO 98/16830</p> <p>(43) International Publication Date: 23 April 1998 (23.04.98)</p>
<p>(21) International Application Number: PCT/US97/19110</p> <p>(22) International Filing Date: 15 October 1997 (15.10.97)</p> <p>(30) Priority Data: 60/029,128 16 October 1996 (16.10.96) US 60/049,864 6 June 1997 (06.06.97) US</p> <p>(71) Applicant: THE PRESIDENT AND FELLOWS OF HARVARD COLLEGE [US/US]; 17 Quincy Street, Cambridge, MA 02138 (US).</p> <p>(72) Inventors: SCHREIBER, Stuart, L.; 434 Marlborough Street, Boston, MA 02116 (US). SHAIR, Matthew, D.; Apartment 2, 16 Foskett Street, Somerville, MA 02144 (US). BORCHARDT, Allen, J.; Apartment 14, 2 Arlington Street, Cambridge, MA 02138 (US). YOU, Angie, J.; 498 Adams House, Cambridge, MA 02138 (US). HUANG, Jing; Apartment 2, 66 Z Prentiss Street, Cambridge, MA 02140 (US). FOLEY, Mike; 107 Conwell Avenue, Somerville, MA 02144 (US). TAN, Derek; 23 Berkeley Street, Cambridge, MA 02138 (US). WHITESIDES, George; 124 Grasmere Street, Newton, MA 02158 (US). JACKMAN, Rebecca, J.; Apartment 2, 38 Groves Street, Boston, MA 02114 (US).</p>		<p>(74) Agent: JARRELL, Brenda, Herschbach; Choate, Hall & Stewart, Exchange Place, 53 State Street, Boston, MA 02109 (US).</p> <p>(81) Designated States: AL, AM, AT, AU, AZ, BA, BB, BG, BR, BY, CA, CH, CN, CU, CZ, DE, DK, EE, ES, FI, GB, GE, HU, IL, IS, JP, KE, KG, KP, KR, KZ, LC, LK, LR, LS, LT, LU, LV, MD, MG, MK, MN, MW, MX, NO, NZ, PL, PT, RO, RU, SD, SE, SG, SI, SK, TJ, TM, TR, TT, UA, UG, UZ, VN, ARIPO patent (GH, KE, LS, MW, SD, SZ, UG, ZW), Eurasian patent (AM, AZ, BY, KG, KZ, MD, RU, TJ, TM), European patent (AT, BE, CH, DE, DK, ES, FI, FR, GB, GR, IE, IT, LU, MC, NL, PT, SE), OAPI patent (BF, BJ, CF, CG, CI, CM, GA, GN, ML, MR, NE, SN, TD, TG).</p> <p>Published <i>Without international search report and to be republished upon receipt of that report.</i></p>
<p>(54) Title: DROPLET ASSAY SYSTEM</p> <p>(57) Abstract</p> <p>The present invention provides a novel system for identifying compounds having desirable chemical or biological activities. According to the invention, test compounds are introduced into liquid droplets and assayed therein. The system is particularly useful for identifying compounds that act e.g., as catalysts, or that have biological activities. In preferred embodiments of the invention, the compounds are assayed <i>in vivo</i>.</p>		

FOR THE PURPOSES OF INFORMATION ONLY

Codes used to identify States party to the PCT on the front pages of pamphlets publishing international applications under the PCT.

AL	Albania	ES	Spain	LS	Lesotho	SI	Slovenia
AM	Armenia	FI	Finland	LT	Lithuania	SK	Slovakia
AT	Austria	FR	France	LU	Luxembourg	SN	Senegal
AU	Australia	GA	Gabon	LV	Latvia	SZ	Swaziland
AZ	Azerbaijan	GB	United Kingdom	MC	Monaco	TD	Chad
BA	Bosnia and Herzegovina	GE	Georgia	MD	Republic of Moldova	TG	Togo
BB	Barbados	GH	Ghana	MG	Madagascar	TJ	Tajikistan
BE	Belgium	GN	Guinea	MK	The former Yugoslav Republic of Macedonia	TM	Turkmenistan
BF	Burkina Faso	GR	Greece	ML	Mali	TR	Turkey
BG	Bulgaria	HU	Hungary	MN	Mongolia	TT	Trinidad and Tobago
BJ	Benin	IE	Ireland	MR	Mauritania	UA	Ukraine
BR	Brazil	IL	Israel	MW	Malawi	UG	Uganda
BY	Belarus	IS	Iceland	MX	Mexico	US	United States of America
CA	Canada	IT	Italy	NE	Niger	UZ	Uzbekistan
CF	Central African Republic	JP	Japan	NL	Netherlands	VN	Viet Nam
CG	Congo	KE	Kenya	NO	Norway	YU	Yugoslavia
CH	Switzerland	KG	Kyrgyzstan	NZ	New Zealand	ZW	Zimbabwe
CI	Côte d'Ivoire	KP	Democratic People's Republic of Korea	PL	Poland		
CM	Cameroon	KR	Republic of Korea	PT	Portugal		
CN	China	KZ	Kazakstan	RO	Romania		
CU	Cuba	LC	Saint Lucia	RU	Russian Federation		
CZ	Czech Republic	LI	Liechtenstein	SD	Sudan		
DE	Germany	LK	Sri Lanka	SE	Sweden		
DK	Denmark	LR	Liberia	SG	Singapore		
EE	Estonia						

DROPLET ASSAY SYSTEM

Related Applications

The present application is a Continuation-in-part of co-pending application
5 number 60/049,864, filed June 6, 1997, the entire contents of which are
incorporated herein by reference.

Background of the Invention

The primary goal of the biotechnology industry is to identify new
10 compounds that can alter biological processes. Various technologies have been
developed that allow production of "combinatorial libraries" of synthetic
compounds that can be screened for those that have a desired activity (see, for
example, Gordon et al., *J. Med. Chem.* 37:1385, 1994; Gallop et al., *J. Med.*
Chem 37:1233, 1994; Kerr et al., *J. Am. Chem. Soc.* 115:2529, 1993; Nikolaiev
15 et al., *Pept. Res.* 6:161, 1993; Needels et al., *Proc. Natl. Acad. Sci. USA*
90:10700, 1993; Ohlmeyer et al., *Proc. Natl. Acad. Sci. USA* 90:10922, 1993;
Brenner et al., *Proc. Natl. Acad. Sci. USA* 89:5181, 1992; Furka et al., *Int. J.*
Pept. Prot. Res. 37:487, 1991).

Although these libraries are valuable resources in the search for
20 identification of new compounds with desirable activities, there are practical
difficulties associated with screening them. In particular, it is often difficult to
sufficiently isolate individual compounds so that their properties can be assessed
independent of other compounds in the library. Compounds can sometimes be
isolated from one another by attachment to a physical support, but then activity of
25 the compounds generally cannot be determined *in vivo*. Where assays are
performed in solution, diffusion by the compounds can pose serious problems.
Various attempts have been made to overcome these problems (see, for example
Quillan et al., *Proc. Natl. Acad. Sci. USA*, 92:2894, 1995), but there remains a
need for development of a screening system that allows analysis of individual test
30 compounds to identify those with desirable activities.

Summary of the Invention

The present invention provides a system for simultaneously screening a large number of compounds to identify those that have desirable chemical or biological activities. According to the invention, individual test compounds are isolated in droplets of liquid within which their activities are studied. Multiple droplets are displayed simultaneously on a single surface without risk of confusion because the separate identity of each droplet is maintained and diffusion of test compounds from one droplet to another is avoided. In certain embodiments, these goals are accomplished through reliance on droplet surface tension; in other embodiments, the droplets are localized in micro-wells that retain droplet integrity.

One aspect of the present invention is a delivery device that deposits compound-containing liquid droplets on a display surface. Another aspect of the invention is the display surface containing such liquid droplets. Yet another aspect of the invention is a method for assaying chemical or biological activities of test compounds by introducing them into individual liquid droplets, displaying the droplets on a surface, and detecting a pre-determined activity within the displayed droplets.

20

Description of the Drawings

Figure 1 presents schematic representations of certain embodiments of the droplet assay system of the present invention. Figure 1A shows a "stochastic" embodiment of the invention; Figure 1B shows an "arrayed" embodiment.

Figure 2 depicts two embodiments (shown in Panels A and B) of the inventive droplet assay system that allow *in vivo* assays under changing culture conditions.

Figure 3 presents structures of several different severable linkers by which test compounds may be attached to supports.

Figure 4 presents a preferred embodiment of the assay system of the present invention, utilizing test compounds attached to a support by means of a photosensitive link.

Figure 5 depicts an *in vivo* assay according to the present invention.

Figure 6 presents a representative synthesis of a photocleavable linker.

Figure 7 depicts a reaction scheme used to prepare a shikimic acid-based combinatorial library suitable for use in accordance with the present invention.

5 Figure 8 shows certain solid phase reactions utilized in preparing the above-mentioned shikimic acid-based combinatorial library.

Figures 9-12 show certain reactions to which tetracyclic templates were subjected in preparing the above-mentioned shikimic acid-based combinatorial library.

10 Figure 13 shows an alternative scheme for preparing a shikimic acid-based combinatorial library for use in accordance with the present invention.

Figure 14-15 show representative monomers for use in functionalizing templates in preparing shikimic acid-based combinatorial libraries.

15 Figure 16 depicts example members of shikimic acid-based combinatorial libraries.

Figure 17 shows linkage of shikimic acid library members to FK506.

Figure 18 shows synthesis of a dioxalane-based combinatorial library for use in accordance with the present invention. Panel A shows the overall reaction scheme; Panel B shows representative monomers used in the reaction scheme;
20 Panel C shows representative library members.

Figure 19 shows synthesis of a pyridinium salt-based combinatorial library.

Figure 20 shows representative pyridine nuclei, bromoketones, and dienophiles.

25 Figure 21 presents a more detailed reaction scheme for preparation of the above-mentioned pyridinium salt-based combinatorial library.

Figure 22 shows representative monomers (Panel A) used in preparation of the above-mentioned pyridinium salt-based combinatorial library, and also shows (Panel B) representative members of that library.

30 Figure 23 depicts the preparation of a rapamycin-bound photocleavable resin for use in the practice of the present invention.

Figure 24 presents a particular embodiment of a spray gun for use in the practice of the present invention.

Figure 25 depicts the introduction of support-bound test compounds into liquid droplets containing yeast cells.

Figure 26 depicts the use of the inventive assay system to detect inhibition of yeast cell growth by rapamycin.

5 Figure 27 shows results of a droplet assay to detect inhibition of yeast cell growth by rapamycin.

Figure 28 depicts a preferred "arrayed" assay embodiment of the present invention.

Figure 29 shows a scanned image of arrayed droplets.

10 Figure 30 shows the structure of a test compound utilized in one embodiment of the present invention.

Figure 31 shows the results of an inventive assay detecting activity of the compound depicted in Figure 30.

15 Figure 32 depicts a transcriptional activation dimerization read-out assay for use in the practice of the present invention.

Figure 33 depicts the use of a transcriptional activation dimerization assay in a droplet assay of the present invention.

Figure 34 presents a traditional reverse two hybrid transcriptional activation system.

20 Figure 35 depicts an improved reverse two hybrid system developed in the present invention.

Figure 36 depicts a particular embodiment of the inventive improved reverse two hybrid system. Panel A shows the yeast strain constructed; Panel B depicts use of the system.

25 Figure 37 shows results achieved with the inventive reverse two hybrid system.

Figure 38 depicts a three-hybrid transcriptional activation dimerization assay for use in the practice of the present invention.

30 Figure 39 depicts a dual library three-hybrid transcriptional activation dimerization assay for use in the practice of the present invention.

Figure 40 depicts a dual library screen in accordance with the present invention.

Figure 41 depicts a translocation dimerization assay for use in the practice of the present invention.

Figure 42 depicts an apoptosis dimerization assay for use in the practice of the present invention.

5

Description of Preferred Embodiments

The System

The present invention provides a system in which test compounds are introduced into and assayed within individual liquid droplets. In preferred
10 embodiments, the test compounds and liquid are combined together and are deposited onto a display surface in a manner that produces liquid droplets containing a limited number of test compounds per droplet. Figure 1A depicts one preferred embodiment of the invention, in which the test compounds **100** and liquid **200** are combined together within a delivery device **300** that is used to
15 deposit droplets **500** onto a display surface **400** in a "stochastic" manner. As used herein, the term "stochastic" describes a display process in which the positioning of the resultant droplets is not controlled, so that droplets are displayed substantially randomly on the display surface. Figure 1B presents an alternative preferred embodiment, in which the droplets **500** are "arrayed" on the display
20 surface **400**. In the "arrayed" embodiment presented in Figure 1B, each droplet **500** has substantially the same volume, and the droplets **500** are arranged on the display surface **400** in a pre-determined pattern.

Each test compound is preferably provided in a manner that guarantees that multiple molecules of the compound are introduced into each droplet that receives
25 a compound. For example, in preferred embodiments, the test compounds are provided in association with a support to which multiple molecules are directly or indirectly attached. Any form of packaging that bundles multiple test compound molecules together in a manner that allows simultaneous introduction of all of the molecules into a single liquid droplet qualifies as a "support" as that term is used
30 in the present application. Preferred support materials include solid polymer materials such as, for example, polydextran, sephadex, polystyrene, polyethylene glycol, polyacrylamide, cellulose, and combinations thereof. Glass, latex, acrylic,

or ceramic supports may also be employed, as may any of a variety of encapsulation matrices.

Where supports are utilized, the supports (with attached test compounds) are combined with the liquid and support-containing liquid droplets are deposited on the display surface. The system is designed so that each droplet receives either
5 no supports or a limited number of supports. Preferably, the droplets that receive a support receive, on average, only one support. However, it is recognized that in some cases it will be desirable to design the system so that the droplets that receive a support receive, on average, more than one support (see below for
10 further discussion).

Test compounds may be attached to the support by any available mechanism. For example, a test compound may be covalently linked with the support, or may be associated with the support through a binding interaction (e.g., by means of ionic, electrostatic, and/or hydrogen-bonding interactions). Also, test
15 compounds may be attached to another molecule that is in turn attached to the support. In certain preferred embodiments of the invention described in the Examples, approximately 100 pmol of compound were loaded onto each bead support.

In preferred embodiments of the invention, test compounds are reversibly
20 associated with the support so that, after a support is introduced into a droplet, test compound(s) attached to the support can be released from the support and assayed. Of course, to the extent that a compound's activity can be assayed without releasing it from the support, such release is not required. Any severable linkage may be employed to attach test compounds to beads. A wide variety of chemical
25 compounds that act as severable linkers sensitive to cleavage by, for example, exposure to acids, bases, or electromagnetic radiation of appropriate wavelength are known in the art (for review, see, for example, Fruchtel et al., *Angew. Chem. Int. Ed. Engl.* 35:17, 1996, Tables 2 and 3 of which are incorporated herein by reference). Figure 2 presents the chemical structures of an array of several such
30 severable chemical linkers.

Severable linkage may alternatively be accomplished by linking the test compound molecules to an agent, such as a protein or polypeptide, that is sensitive

to cleavage by a known enzyme or chemical cleavage agent (see, for example, glutathione-S-transferase [GST] fusion system available from Pharmacia). A wide variety of chemical (e.g., cyanogen bromide) and enzymatic (e.g., trypsin, chymotrypsin, carboxypeptidase Y, precursor protein processing enzymes, etc.),
5 protein cleavage agents with specific recognition sites are known in the art (see, for example, Hermodson, *Methods in Protein Sequencing Analysis*, ed. Elzinga, Humons Press, Clifton, NJ, pp. 313-323, 1982; see also Sigma Chemical Company catalog listing of Protein Analysis Reagents, each of which is incorporated herein by reference). Alternatively, the test compound molecules may
10 be linked to a nucleic acid molecule that contains a cleavage site for a restriction endonuclease or other nucleic acid cleaving agent (e.g., a ribozyme). Test compounds may also be attached by means of, for example, a disulfate linker that will be cleaved by exposure to reducing conditions (e.g., the interior of a cell).

Severable linkage may also be accomplished if the association between the
15 test compound and the support to can be competed out by exposure to a competitive agent. For example, test compounds fused to GST will bind to a solid support to which glutathione is attached, and this binding can be competed by free glutathione.

Preferred severable linkages are those that allow the extent of compound
20 release to be controlled by exposure to varying degrees of release signal, and therefore allow control of the concentration of active test compound in the droplet. For example, the extent of severance of photo-cleavable linkages can generally be varied by altering the time of exposure to radiation of the appropriate wavelength (see, for example, Example 6). Similarly, the extent of severance of competable
25 attachments can be adjusted by altering the concentration of competitive agent.

It will be appreciated that the concentration of test compound achieved in any particular droplet will depend both on the extent of release of compound in the droplet and on the volume of the droplet. Accordingly, one advantage of certain
30 "arrayed" embodiments of the present invention, as compared with most stochastic embodiments, is that arrayed droplets typically have substantially identical volumes. Under such circumstances, exposure of each droplet to the same extent of compound release (e.g., to radiation applied for the same amount of time)

produces the same concentration of test compound in each droplet, allowing straightforward side-by-side comparisons.

Regardless of the mode of attachment between the test compound molecules and the support, it is generally preferred that each support have approximately the same number of molecules attached to it, so that every droplet that receives a support receives approximately the same number of test compound molecules. Thus when, for example, the support is in the shape of a bead, it is generally desirable for all support beads to be substantially the same size so that approximately uniform loading can be readily accomplished.

It is also generally preferred that a single test compound be associated with each support. In such cases, introduction of one support into one droplet allows analysis of the activity of the particular test compound associated with the support. It is appreciated that in some instances it will be desirable to introduce more than one test compound into a single droplet at the same time. For example, it will sometimes be desirable to assay for synergistic, cooperative, or competitive interactions between or among test compounds. Alternatively or additionally, if the collection ("library") of test compounds to be screened is very large, it may be desirable to assay sub-collections of test compounds together, detect those sub-collections that include one or more test compounds having the desired activity, and then to screen the sub-collections to identify the individual desirable test compounds within the sub-collections.

Approaches that allow introduction of multiple test compounds into a single liquid droplet include, for example, attaching multiple test compounds to a single support or introducing multiple supports, each of which contains only one attached test compound, into a single droplet.

The number of test molecules introduced into a droplet may depend on the extent to which test molecules were loaded on the support (i.e., the number of molecules initially attached to the support), the concentration of supports in the liquid/support mixture, the extent of release of test compound molecules from the support, and the size of the liquid droplets. In the "stochastic" embodiment depicted in Figure 1A, or in other embodiments in which droplets are delivered to the display surface by spraying or related procedure, the size of the liquid droplets

is adjusted by altering the rate at which the liquid is ejected from the delivery device, the extent of air flow within the device, the size of the aperture through which the droplets are delivered, the surface tension of the liquid and/or the viscosity of the liquid. In certain arrayed embodiments, where the droplets are displayed on a surface containing wells or pockets (i.e., indentations) (see, for example, Example 7), the size of the well or pocket determines the size of the droplet.

Liquid viscosity (and surface tension) may be altered, for example, by selecting a liquid that inherently has the desired viscosity or by providing an additive that alters the liquid viscosity. Available liquids and additives are known in the art. It will be appreciated that liquid viscosity can affect not only droplet size but also, and perhaps more importantly, the ease with which supports are delivered to liquid droplets. Effective delivery generally requires that the supports be maintained in a substantially uniform suspension in the liquid; liquid viscosity should preferably be selected to assist in the accomplishment of this goal. Of course, the importance of liquid viscosity in maintaining support suspension is reduced when the delivery device is designed to maintain effective suspension itself (e.g., by incorporating a mixing device). Liquid viscosity may also affect evaporation.

Preferred droplet sizes are determined by the display and read-out systems employed. Particularly preferred are approximately 50 nL or 100 nL (volume) droplets. Once the desired droplet size is selected, the number of supports introduced per droplet can readily be set by dilution of the support/liquid mixture.

The surface on which the droplets are displayed is selected so that droplets maintain their discrete form when located on it and test compounds do not diffuse from one droplet to another through the support. Preferably, the surface is selected and/or utilized so that each droplet is also substantially immobilized on the surface. In certain preferred embodiments, a display surface containing wells or pockets is utilized, so that droplet discreteness is ensured and diffusion problems are substantially avoided. Preferred surfaces for use with aqueous solutions include plastic, glass, and membranes, including polymer membranes.

Preferred polymer membranes include, for example, membranes formed from polymethyl methacrylate, polyurethane, or polydimethyl siloxane (PDMS).

Once the compound-containing droplets are displayed, compound activity can be analyzed using any of a variety of "read-out" assays (see below). The selection of read-out assay may well influence the choice of materials employed in the display surface. For example, where the read-out assay involves detection of a fluorescent molecule that is only detectable after excitation, it may be desirable to use a display surface that is transparent to the excitation (and/or emission) radiation; where the read-out assay utilizes living cells, the display material must be compatible with continued viability. Other relevant considerations will be apparent to those of ordinary skill in the art.

Also, where the read-out assay is one that takes many days to complete (as is true of many assays for biological activity and particularly for many *in vivo* assays), the system is designed (e.g., liquid and/or display surface are selected, conditions of reaction are controlled) to minimize droplet evaporation. For example, certain preferred embodiments of the invention utilize plastic petri dishes as display surfaces. Such petri dishes can readily be wrapped, or can be placed in a humid environment, to avoid evaporation.

Further, particularized system components may be selected for read-out assays that utilize living cells. For example, efforts will be made to maintain cell viability. Also, in some cases it may be desirable to use a display surface that permits alteration of the growth environment. Certain membranes, for example, can be placed on top of growth media and can be moved from one growth medium to another. For Example, Figure 2 depicts a "replica-plating" embodiment of the invention, in which cell-containing droplets 500 are deposited on a display surface 400 comprising a movable membrane. The membrane is placed on a first growth medium 550 for a period of time and then is transferred to a second growth medium 560. As is known in the art, such procedures are particularly useful with, for example, yeast or bacterial cells.

It may not be desirable to place droplet-containing display surfaces on growth media during the assay stage of the invention as such placement might allow compounds to diffuse between droplets by passing through the medium;

however, various periods of growth may be desired after the assay period where such diffusion may be less of a concern. Alternatively, Figure 2 presents an embodiment of the inventive droplet assay system in which changes to the growth medium can be accomplished without concern over diffusion among droplets. In this embodiment, cell-containing droplets **500** are arrayed in wells **580** on a first display surface **400a**. The first display surface **400a** is overlaid with a second display surface **400b** to which cells in the droplets **500**, and the droplets **500** themselves, adhere (e.g., a fibronectin-coated glass coverslip if the cells are fibroblasts). The second display surface **400b**, containing the droplets **500** and cells, can then be exposed to treatments that will modify the medium composition in the droplets **500**. For example, it may be overlaid on a third display surface, which third display surface has wells substantially identical to those on the first display surface except that the wells on the third display surface contain one or more chemicals that alter the composition of the droplet medium when the droplets are introduced into the wells.

The read-out assays identify those droplets that contain test compounds displaying the desired activity. The test compounds present in those droplets are then identified, for example by being isolated from the droplet or by other means. In preferred embodiments of the invention, where the test compounds were provided in association with a support, each support contains information about the chemical structure of the compound with which it was associated, so that the compound can be identified by isolation and analysis of the support (see below for further discussion).

When a droplet that is identified as containing a compound with the desired activity contains more than one compound, a second round of screening is typically performed to identify which one of the compounds (or which combination of compounds) within the droplet actually has the activity.

The Delivery Device

Any device capable of depositing liquid droplets on a display surface may be utilized in the practice of the present invention. The characteristics and mechanics of the device will vary depending upon the desired method of delivery.

The delivery device of the present invention may be constructed and arranged to deposit drops in series (i.e., one at a time) or simultaneously, or merely to deliver liquid and test compounds to the display surface in a manner that allows subsequent formation and/or arrangement of droplets. For example, in the
5 inventive embodiment depicted in Figure 1A, the delivery device has a spray-type action. By contrast, in the inventive embodiment depicted in Figure 28 (described in detail below), the delivery device deposits a single sample of liquid/test compound suspension on the display surface, and the droplets are distributed on the surface through a wetting/dewetting procedure (see Example 7).

10 Generally, any device in which liquid passes through an opening can be engineered to deposit droplets. For example, any known spray device, such as an atomizer, a spray gun, a syringe, or any sort of squirt bottle, may be utilized. Alternatively, an automatic or manual pipetter may be used. For example, a multi-tip manual pipetter can be employed to simultaneously deposit a large
15 number of droplets in a defined array on a surface; a single-tip pipetter may be used when the droplets are to be distributed by a mechanism separate from their delivery (e.g., in the embodiment depicted in Figure 28).

The Library

20 The present invention can be used to screen virtually any collection of test compounds. So long as the test compounds can be introduced into liquid droplets and assayed as described herein, they can be utilized in the practice of the present invention.

In most cases, as discussed above, it will be desirable to use libraries of
25 test compounds that are mounted on, or otherwise associated with, a support. It is preferred, although not required, that the support contain information identifying the compound with which it is associated so that isolation and analysis of the support constitutes identification of the compound (see below for further discussion of desirable means of identification). It is also preferred, as discussed above, that
30 the association between the compound and the support be severable so that the compound can be released from the support after being introduced into the droplet. Severable attachment of the compound to the support provides the additional

advantage that the concentration of active test compound in the droplet can be varied by altering the extent of exposure of the droplet to the agent responsible for disrupting the compound-support attachment (unless, of course, the compound is active without being released from the support). Figure 3 depicts examples of a variety of known severable linkers that can be used to attach test compounds to supports according to the present invention.

Test compounds, whether or not attached to a support, may be linked to another molecule or material. For Example, some of the Examples presented below describe embodiments of the invention in which each member compound in a combinatorial library is functionalized with a common molecule. The common molecule is then utilized in the read-out assay that is used to evaluate the test compounds (see below).

The assay system of the present invention is particularly suitable for analyzing synthetic chemical libraries produced by combinatorial synthesis. Many examples of such libraries are known in the art, as are methods for producing them, such as "split and pool" or "parallel" solid phase synthesis (see, for example, Furka et al., *Abstr. 14th Congr. Biochem.*, Prague, Czechoslovakia, 5:47, 1988; Furka et al., *Int. J. Pept. Protein Res.* 37:487, 1991; Lom et al., *Nature* 354:82, 1991, each of which is incorporated herein by reference; see also Fruchtel et al., *Angew. Chem. Int. Ed. Engl.* 35:17, 1996, incorporated herein by reference, and references cited therein). These techniques allow for the generation of large libraries of compounds, each of which is attached (in multiple copies) to a single support.

Those of ordinary skill in the art will appreciate that, when a library of test compounds is to be synthesized directly on a support, the support must be selected to be compatible with the chemistry involved in synthesis. Various considerations associated with selection of supports for use in combinatorial library synthesis are discussed in Fruchtel et al. (*Angew. Chem. Int. Ed. Engl.* 35:17, 1996; see especially pp. 17-21 and Table 1, incorporated herein by reference). A wide variety of reactions that can be carried out on solid supports are also known (see, for example, pp. 21-24 and Table 4 of Fruchtel et al. (*Angew. Chem. Int. Ed. Engl.* 35:17, 1996, incorporated herein by reference).

When the library of test compounds used in the practice of the present invention is produced by combinatorial synthesis, the steps in the synthetic reaction are known. Thus, the particular test compound (or compounds) attached to a specific bead can be determined through a process of deconvolution (see, for example, Houghton et al., *Biotechnology* 13:901, 1992; Houghton et al., *Nature* 354:84, 1991, each of which is incorporated herein by reference). However, deconvolution can be a laborious process. Accordingly, preferred combinatorial libraries for use in the present invention are "encoded" or "tagged" libraries, in which each compound is attached to a support that also contains an identifier tag defining the compound (Ni et al., *Met. Enzymol.* 267:261, 1996; Nestler et al., *J. Org. Chem.* 59:4823, 1994; Ohlmeyer et al., *Proc. Natl. Acad. Sci. USA* 90:10922, 1993; Kerr et al., *J. Am. Chem. Soc.* 115:2529, 1993; Nikolaiev et al., *Pept. Res.* 6:161, 1993; Needels et al., *Proc. Natl. Acad. Sci. USA*, 90:10700, 1993; Furka et al., *Abstr. 14th Int. Congr. Biochem*, Prague, Czechoslovakia, 5:47, 1988, each of which is incorporated herein by reference). These tags are typically molecules that can be cleaved from the bead and that, when analyzed, allow the synthetic history of the test compound attached to the bead to be retraced.

In a particularly preferred embodiment of the invention, depicted in Figure 4, an encoded combinatorial library in which the compounds **100a-n** are attached to beads **600** through a photocleavable linker **800** is utilized. Each bead **600** is labeled with a tag **900a-n** that identifies the bound compound **100a-n**. The photocleavable linker **800** is UV-sensitive. In this embodiment, the concentration of test compound released in the droplet can be controlled by controlling the time of exposure to UV radiation. For example, as presented in Example 6, exposure to 15 seconds of radiation at 365 nm releases enough test compound to give a concentration in the range of approximately 50-100 nM in a 100 nL droplet. The amount of compound released in any particular experiment, of course, will depend on the efficiency of bead loading and the extent of bead functionalization.

30

The Read-out Assays

Those of ordinary skill in the art will readily appreciate that any of a wide variety of read-out assays can be employed with the assay system of the present invention. Many possibilities are described in the following Examples; the
5 described assays are merely some of the possibilities and their description is not intended to limit the scope of the present invention. Any assay whose result may be observed in the context of a discrete liquid droplet is appropriate for use with the present invention.

Preferred read-out assays for use in accordance with the present invention
10 analyze chemical or biological activities of test compounds. Read-out assays can be designed to test *in vitro* or *in vivo* activities. Both kinds of assays are illustrated in the Examples. Many preferred embodiments of the invention utilize read-out assays that test *in vivo* activities.

Figure 5 illustrates one preferred embodiment of the invention, utilizing an
15 *in vivo* read-out assay. As shown, test compounds **100** are detachably linked to beads **600** and are mixed with cells **700** in a liquid **200** that is selected to be compatible with cell viability. The mixture is sprayed out of a delivery device **300** so that liquid droplets **500** are stochastically deposited on a display surface **400**. In preferred embodiments of the invention, each liquid droplet **500** contains about
20 1-100,000 cells, preferably about 10-10,000 cells. The number of cells per droplet is dependent on the droplet size and the concentration of cells in the original mixture and is therefore readily adjustable.

As shown in Figure 5, after the droplets are formed, the test compounds
25 **100** are released from the beads **600** so that they may enter the cells and their effects on the cells can be detected. It will be recognized that the system depicted in Figure 5 will only identify cell-permeable compounds and compounds that exert their effects externally to cells. *In vitro* assay systems can be utilized to detect other classes of compounds (see, for example, Examples 15 and 17). However, because many, if not most, pharmaceutical applications involve extracellular
30 administration of active agents, it is anticipated that many of the most useful biologically active compounds identified with the present system will be cell-permeable compounds or compounds that act outside of cells.

Preferred read-out assays for use in detecting compounds with biological activity according to the present invention include assays that detect cell growth; cell death (or absence of growth); changes in cell morphology; changes in expression or localization of a colored, fluorescent, or otherwise detectable marker; etc.

It will be appreciated by those of ordinary skill in the art that the desired activity to be identified will often determine the cell type employed in the assay. In general, any cell (e.g., bacterial, yeast, human, or animal) whose viability can be maintained under the conditions of the experiment can be employed in the practice of the invention. Selections will typically be made based on convenience, availability, and appropriateness to the assay. For example, assays that detect cell growth or cell death may desirably be used to identify antibiotic and/or antifungal agents by performing assays on bacterial and/or fungal (e.g., yeast) cells. Preferably, the assays are repeated on human and/or animal cells in order to identify those agents that inhibit bacterial and/or fungal cell growth without disrupting human or animal cell viability.

The following section presents Examples of certain detailed protocols and preferred read-out assays for use in the practice of the present invention. It will be appreciated by those of ordinary skill in the art that the following Examples are merely a few versions of the infinite variety of embodiments of the invention. For example, many of the read-out assays described below detect ligand-receptor interactions by assaying for expression of a gene that is required for cell growth under the conditions of the assay. Those of ordinary skill in the art will recognize that the described "selection" could equally well be performed as a "screen" that assays expression of a detectable gene (e.g., a gene encoding a protein that is colored or that produces a color in a known assay). Examples of detectable genes commonly used in biological assay systems include the green fluorescent protein gene (or fusions therewith), the β -galactosidase gene, the invertase gene, the luciferase gene, the alkaline phosphatase gene, the horse radish peroxidase gene, etc.

Examples

Example 1: Preparation of Combinatorial Libraries of Test Compounds

We have used combinatorial synthetic chemistry to generate different libraries of molecules that either project various functionalities in a radial array
5 around a central scaffold, or that achieve diversification by condensation of
“combinatorializable units” that are varied by altering the functional groups of the
synthetic reagents in the synthetic pathway. Preferably, libraries are assembled on
the solid phase (e.g., while attached to a resin), for example using “split and
pool” synthesis or “in parallel” synthesis. In particularly preferred embodiments,
10 the library molecules are attached to the resin via a photocleavable linking unit, so
that exposure to UV light releases the molecule from the resin. A representative
synthesis of a photocleavable linker is shown in Figure 6.

a) *Shikimic Acid-Based Combinatorial Library*

15 Figure 7 presents the reaction scheme we have utilized to prepare one of
the preferred combinatorial libraries of the present invention. This library projects
various functionalities in a radial array around a central scaffold experimental
details for the preparation of this library are presented in Appendix A. Briefly,
enantiomeric templates produced from shikimic acid (1) were converted to solid-
20 phase-bound epoxyol templates (4). The template was then treated with a variety
of nitrones (5), under the influence of an esterification promoter, so that a
corresponding tetracyclic system (6) was produced. As can be seen, six
alternative tetracyclic templates (6a-e) were made. These templates were then
subjected to several different reactions to produce a library of compounds by a
25 split and pool technique (see Figure 8). As will be appreciated by those of
ordinary skill in the art, the specific reactions depicted in Figure 2 are merely
examples of the reactions that could be employed; any of a variety of alternative
reactions can be used with a split and pool technique (*see* Furka et al., *Abstr. 14th*
Congr. Biochem., Prague, Czechoslovakia, 5:47, 1988; Furka et al., *Int. J. Pept.*
30 *Protein Res.* 37:487, 1991). Also, a parallel synthesis technique could equally
well be used. Whatever the approach, libraries of more than 10,000 different
chemical compounds can readily be produced.

Specific reactions to which some or all of the tetracyclic systems (6) were subjected include i) addition of nucleophiles (primary and secondary amines) to the γ -lactone function (see Figure 9); ii) functionalization of the free hydroxyl with electrophiles (for example, isocyanates or acid chlorides) (Figure 10); iii) opening
5 of the epoxide with nucleophiles, such as amines, under ytterbium catalysis (see Figure 11); iv) cleavage of the N-O bond of tetrahydroisoxazole to release a 1,3-amino alcohol that can be functionalized by various electrophiles such as acid chlorides, sulfonyl chlorides, or isocyanates; and v) functionalization at the iodide
10 in the aromatic ring, for example by conversion to such structures as amines, amides, aromatic rings, alkenes, alkynes, and heterocycles using palladium-catalyzed chemistry (Figure 12).

Alternatively or additionally, other shikimate-derived radial arrayed libraries can be synthesized by substitution of a nitrene based cycloaddition reaction with azomethane ylide cycloadditions, tributyltin hydride radical
15 cyclizations, or 1,3 dipolar addition reactions to generate templates 2, 3, or 4 respectively (Figure 13). These templates can be functionalized similarly to templates 6a-e discussed above by employing reactions such as palladium cross-couplings, N-acylating lactone openings, lactone alcohol acylations, epoxide
20 openings and epoxide alcohol acylations. In fact, the first template depicted in Figure 7 is identical to template 6e. Representative monomers that can be used to diversify these templates are shown in Figures 14 and 15. Additionally, Figure 16 shows representative library members for each of the different shikimate-derived
25 templates. Those of ordinary skill in the art will appreciate that additional functionalization at any of the reactive sites will yield further diversification (see Appendix B).

In preferred embodiments of the present invention, one of the sites on the tetracyclic system is functionalized with a ligand so that every molecule in the library is attached to the same ligand. Any desirable ligand may be used; we have performed a linkage to FK506 (see Figure 17).

30

b) *Dioxalane-Based Combinatorial Library*

Figure 18 presents the reaction scheme we have utilized to prepare another preferred combinatorial library for use in the present invention; experimental
5 details are presented in Appendix B. This system achieves diversification by condensation of 4 "combinatorializable units" in contrast to the shikimic acid based combinatorial library which diversifies in a radial array.

As shown in Figure 18, the synthesis of this library begins by selecting the base monomer, (1), which is an epoxide. Representative examples of suitable
10 epoxides are shown in Figure 18B. Conversion of this base monomer to a solid phase bound template (2) was achieved using the coupling agent HATU ([O-(7-azabenzotriazol-1-yl)-1,1,3,3-tetramethyluronium hexafluorophosphate]) and diisopropylethylamine. The epoxide was then subjected to reaction with another
15 "combinatorializable unit", a secondary amine (3) (see Figure 18B for examples of suitable secondary amines) under ytterbium catalysis to produce the diol (4). The diol, upon reaction with an aldehyde (5) (see Figure 18B for examples of suitable aldehydes) and trimethylsilyl chloride, results in the acetal (6). After deprotection of the protecting group and subsequent reaction with a "capping group", the dioxalane (8) is produced. The capping group is preferably an acylating agent (7)
20 (see Figure 18B for examples of suitable agents).

Those of ordinary skill in the art will appreciate that the monomers depicted in Figure 12B are merely representative compounds and are not intended to limit the scope of the present invention. For example, alternative aldehydes (5)
25 that could be utilized include, but are in no way limited to, 3-((9-fluorenylmethoxycarbonyl)-amino)-benzaldehyde, 3-((9-fluorenylmethoxycarbonyl)-amino)-4-methyl-benzaldehyde and 3-((9-fluorenylmethoxycarbonyl)-amino)-4-methoxy-benzaldehyde.

Representative synthetic molecules resulting from this pathway are depicted in Figure 18C, but are in no way limited to these molecules. Any of a variety of
30 the reactions can be used with a split and pool or parallel synthesis technique to easily produce more than 10,000 different chemical compounds.

c) *Pyridinium-Based Combinatorial Library*

Figure 19 presents the reaction scheme we have utilized to prepare yet another combinatorial library appropriate for use in the present invention; experimental details are presented in Appendix C. As shown in Figure 19, both a
5 N-alkyl based pyridinium salt library and aracyl based library can be synthesized. The N-alkyl based library can be synthesized from a pyridine nucleus, whose functionality can be varied, upon reaction with a dienophile, to include halogens, alkyl groups, and halides, or a bromoketone. Further reaction with a dienophile yields the N-alkyl based pyridinium salt library. Representative pyridine nuclei,
10 bromoketones and dienophiles are shown in Figure 20, but are in no way limited to the depicted compounds.

Alternatively, an acyl based pyridinium salt library can be synthesized using the same pyridine based starting material as shown in Figure 19. A more detailed synthetic pathway of the acyl based pyridinium salt library is shown in
15 Figure 21. As depicted, the pyridine nucleus undergoes addition of a nucleophile to an acyl pyridinium salt to produce the dihydropyridine product (2). The acylating agent utilized in this reaction can be varied (using R₁) to diversify. The dihydropyridine product (2) can then be combined with dienophiles, preferably maleic anhydride, to produce a Diels Alder cycloadduct represented by (3). At
20 this stage, the Diels Alder adduct (3) can be reacted with a series of primary amines, of which (4) is representative, in which the anhydride of (3) is converted to the imide (5). The primary amine "combinatorializable unit" can be diversified using R₂ (Figure 22A) and R₃ (Figure 21). The imide (5) is then condensed with various amines (R₄), of which (6) is representative, in an ipso substitution reaction
25 to produce (7). (7) is then exposed to an asymmetric dihydroxylation catalyst to produce diol (8), which can be further diversified by reaction with a series of ketones, of which (9) is representative, under acid catalysis to produce the ketal (10). Diversification is achieved at this step by varying the functionality of the ketone using the groups R₅ and R₆. In Figure 21, structure (10) shows each of
30 the positions at which the molecule can be diversified to produce a combinatorial library. Representative synthetic molecules resulting from this pathway are depicted in Figure 22B, but are in no way limited to these particular structures.

Those of ordinary skill in the art will appreciate that additional functionalization during any of the reaction steps will yield further diversification. Any of the variety of reactions can be used with a split and pool or a parallel synthesis technique to easily produce more than 10,000 different chemical compounds.

5

Example 2: Preparation of a Photocleavable Rapamycin Resin

This Example describes the preparation of a test compound comprising rapamycin linked to a photocleavable resin.

As depicted in Figure 23A, a photocleavable resin was prepared by mixing
10 amino resin (100 mg, 0.025 mmol, 0.25 mmol/gm; TentaGel S NH₂ from RAPP polymere, catalog number S 30902) with photolinker (17.0mg, 0.075 mmol), diisopropyl carbodiimide (11.74 μL, 0.075 mmol), hydroxybenzotriazole (10.13 mg, 0.075 mmol), dimethylformamide (0.5 mL), and methylene chloride (0.5 mL), for 30 min. The reaction product was washed with dimethylformamide (10
15 mL) and methylene chloride (10 mL).

As shown in Figure 23B, the rapamycin-photocleavable resin was prepared by mixing the photocleavable resin of Figure 23A (25 mg, 0.00625 mmol) with phosgene in toluene (0.5 mL, 20% by weight) and N,N-dimethylaniline (7.92 μL, 0.0625-mmol) for 1.5 hr at room temperature. The reaction product was washed
20 with dry methylene chloride (10 mL), under a nitrogen atmosphere. To this resin (20 mg, 0.005 mml) was added rapamycin (14 mg, 0.015 mmol), N-methylmorpholine (3.1 μL, 0.03 mmol), N,N-dimethylaminopyridine (0.5 mg), and dry methylene chloride (200 μL). After being agitated overnight, the beads were washed with dimethyl formamide (10 mL) and methylene chloride (10 mL), and
25 were dried under high vacuum.

Example 3: Construction of a Spray Gun

This Example describes the construction of the spray gun that was employed in Examples 4-6. As shown in Figure 24, we prepared the spray gun by
30 inserting a bent 18 gauge disposable syringe needle (1.5 inch) through the side of a p1000 disposable pipette tip. Nitrogen was flowed in under pressure so that droplets 500 were sprayed onto the display surface 400. It will be recognized that

any of a variety of alternative arrangements could equally well be employed. The only structural requirements for a spray gun is that the aperture must be large enough that any support can pass through it.

5 Example 4: Introduction of a Combinatorial Library of Test Compounds into Stochastically-Displayed Liquid Droplets

This Example describes work that we did in order to assay certain biological activities of test compounds in yeast cells.

We dissolved agar (10 mg) in hot YPD medium (2.0 mL), cooled the
10 solution to a soft solid, pulverized the soft solid by vortexing and pipetting it for 5 minutes, and centrifuged the pulverized material at 14,000 rpm for 1 min. We then removed the top layer of media, which was homogenous and had the consistency of syrup, via pipette, and mixed the removed media with yeast (2.5 mL of a culture grown to saturation in YPD).

15 We then prepared rapamycin-bound beads as described in Example 2, vortexed these beads in dimethyl formamide (DMF; 1.0 mL) for 15 minutes, sonicated them in DMF (1.0 mL) for 15 minutes, and washed them thoroughly with water (4 x 1.0 mL). We then mixed the beads with the media/yeast mixture described above.

20 We loaded the bead/media/yeast slurry into a spray gun, such as that depicted in Figure 24, made from a 1.0 mL disposable sterile syringe, and used a nitrogen gas stream as a propellant to spray droplets of liquid media onto a petri dish (see Figure 25). We adjusted the syringe injection rate and gas flow rate so that approximately 100 nL droplets were obtained. Each droplet contained, on
25 average, one bead and about 100 yeast cells.

Example 5: Detecting Growth Inhibition in Stochastically-Displayed Liquid Droplets/Absence of Diffusion Between Droplets

This Example describes the use of the inventive droplet system to assay the
30 ability of rapamycin to inhibit yeast cell growth. Rapamycin is a known antibiotic whose activity was being assayed only to establish that the inventive assay system could in fact be used to detect growth-inhibiting activity of a test compound. The

work described in this Example established that the assay system is effective and, in particular, established that rapamycin did not diffuse across the petri dish from one droplet to others.

We prepared a mixture of beads, some of which had rapamycin linked to them as described in Example 2 and some of which were N-terminally acetylated (i.e., were "blank"). We combined this bead mixture with yeast cells in liquid YPD media, and sprayed them in YPD droplets on a petri dish, as described in Example 4. The droplets that contained beads contained, on average, one bead. Some droplets contained a bead to which rapamycin was attached, and some droplets contained a blank bead.

We covered the droplet-coated petri dishes, sealed them with parafilm, and split them into two groups, one of which was exposed to UV radiation (using a black ray UV lamp model B 100 AP) for less than one minute and one of which was not exposed to UV radiation at all. We incubated both sets of plates at 30 °C for approximately 18 hours. Figure 26 presents a schematic representation of this experiment and its results; Figure 27 presents photographs of actual droplets on plates. As can be seen, yeast growth was inhibited in rapamycin-bead-containing droplets yeast growth was not inhibited in droplets that lacked beads (see Panel B) yeast growth was also not inhibited in droplets that were not exposed to UV (Panel A); nor in droplets containing *tor* yeast cells that are resistant to rapamycin (Panel C).

The work described in this Example clearly demonstrates that the inventive system can effectively be used to detect antibiotic activity of test compounds. If a combinatorial library were employed rather than the rapamycin-bead/blank bead mixture, any compounds within that library that inhibited yeast growth would readily be identified. Moreover, the same assay can easily be adapted for use with cells other than yeast cells (e.g., bacterial cells, human cells, non-human animal cells, etc.) so that compounds that inhibit growth of any particular cell, or combination of cells, can be discovered.

This Example also demonstrates that test compound (rapamycin) within one liquid droplet does not diffuse into other droplets.

Example 6: Release of Compounds from Beads/Control of Test Compound Concentration

The present Example describes use of a photocleavable linker in a droplet assay of the present invention so that the concentration of test compound in the droplet is varied.

Rapamycin-containing beads were prepared and introduced into droplets as described in Example 5. The droplet-containing petri dishes were split into groups and were exposed to UV radiation for different times (1 min, 30 sec, 15 sec). We found that 15 sec of radiation released approximately the minimal amount of rapamycin needed to inhibit yeast cell growth in the droplets.

Example 7: Preparation of a Display Surface for an Arrayed Droplet Assay

This Example describes the preparation of a display surface containing wells or pockets that can be utilized in certain "arrayed" embodiments of the present assay system.

As depicted in Figure 28, one preferred method of preparing a display surface containing wells of pre-determined configuration and arrangement is by the method of photolithography (see, for example, PCT Application publication number WO 96/29629, incorporated herein by reference). Those of ordinary skill in the art will appreciate that other methods may alternatively be employed and that any method that produces a display surface having wells of appropriate (preferably substantially uniform) size and arrangement is suitable according to the present invention.

In the particular embodiment depicted in Figure 28, an acetate layer **710** on which the desired pattern of wells had been printed was placed on a silicon wafer **730** covered with a photoresist **720**. Irradiation through the acetate layer created a "master" **740** over which a solution of PDMS monomers was poured. Polymerization of the PDMS produced a display surface **400** having wells **580** that were 20 μM deep, 1 μM in diameter, and that were separated from one another by 250 μM .

Test compounds and/or beads were introduced into liquid droplets **500** displayed on the surface **400** by means of a standard wetting/dewetting procedure.

Specifically, compounds (and/or beads) were mixed with liquid and the mixture was applied to the surface. The surface **400** was then rotated so that liquid filled the wells and excess liquid was discarded. Figure 29 shows a scanned image, at 50X magnification, of twelve arrayed droplets achieved by this method. Each droplet was 50 nL in volume. On average, each droplet contained 1-2 beads; the number of beads per droplet ranged from 0 to about 5. Those of ordinary skill in the art will readily appreciate, in light of the teachings presented herein, that the average number of beads per droplet (as well as the range in numbers of beads per droplet) can readily be adjusted by varying, for example, droplet size, bead concentration in the pre-droplet suspension, liquid viscosity, etc.

The use of a wetting/dewetting procedure to distribute droplets has certain advantages in the practice of the present invention. For example, such procedures are very mild, so that the viability of even sensitive cells, such as human stem cells, can be preserved in the procedure, allowing a wide range of read-out assays to be utilized. Of course, other mild procedures, such as manual pipetting (e.g., with a multi-tip pipetter), would likely provide a similar advantage.

Example 8: Detection of Growth Inhibition in Arrayed Liquid Droplets

The present Example describes the use of the arrayed liquid droplet system described in Example 7 to detect growth inhibition by the compound isolated from a combinatorial library.

A combinatorial library of 125,000 molecules was prepared by split-and-pool synthesis, and a single compound within that library was identified in prior experiments as having the ability to inhibit the growth of budding yeast cells. The structure of this compound, as well as its photocleavable linkage to a support bead, is depicted in Figure 30.

The inhibitory compound (attached to its support bead) was combined with a suspension of budding yeast cells and applied to the display surface by a wetting/dewetting procedure (see Figure 28).

Experimental droplets were exposed to 60 seconds of UV radiation, so that the inhibitory compound was released from the beads in those droplets that contained beads, and then were incubated under conditions favorable for cell

growth for 24 hours. As shown in Figure 31, cells did not grow in irradiated droplets that contained beads; cells grew to high density both in irradiated droplets that lacked beads and in non-irradiated droplets.

The work described in this Example demonstrated that the activity of test compounds can be effectively assayed in an arrayed droplet system. This sort of arrayed droplet system has certain advantages as compared with some of the stochastic embodiments described herein. For example, the information derived from assays in these arrayed system can readily be digitized and integrated with robotic systems, so that processing of results is substantially simplified.

10
Example 9: Detecting Ligands (and/or Inhibitors) in an Intracellular Transcriptional Activation Assay Dependent on Dimerization

The present Example describes an application of the droplet system of the present invention to detect test compounds that act as ligands in that they bind to intracellular receptors. The term "receptor", as used herein, refers to any protein to which a ligand binds. The assay described in this Example can also be used to detect compounds that inhibit interactions between ligands and their receptors.

The read-out assay utilized in this embodiment of the invention detects the transcriptional activation of a gene required for cell growth. The assay is presented schematically in Figure 32: a binding site **1400** for a known DNA binding entity (e.g., a protein or protein domain, and anti-DNA antibody, an intercalation compound, a nucleic acid capable of triple helix formation, etc.) is positioned upstream of a reporter gene **1500** that is essential under the conditions of the assay (e.g., a gene required to produce a metabolite that is not present in the growth medium). The DNA binding entity **1600** is fused to a first target receptor **1700**, and a second target receptor **1800** is fused to a transcriptional activation domain **1900**. The first **1700** and second **1800** target receptors may or may not be the same.

The system depicted in Figure 32 is arranged so that in the absence of a ligand, the DNA binding entity **1600** and transcriptional activation domain **1900** do not interact with one another and the gene is not expressed. Provision of a ligand **100** (also called a "dimerizer") that interacts with both the first **1700** and second

1800 target receptors, however, allows the transcriptional activation domain 1900 to be recruited to the DNA binding entity 1600 so that transcription of the gene 1500 is activated.

A wide variety of DNA-binding entities (see, for example, U.S. Patent No. 5,578,444; Nelson, *Curr. Op. Genet. Dev.* 5:180, 1995; Wade et al., *JACS* 114:8784, 1992; Mrksich et al., *Proc. Natl. Acad. Sci. USA* 89:7586, 1992; Mrksich et al., *JACS* 115:2572, 1993; Mrksich et al., *JACS* 116:7983, 1994; Stollar, *Faseb J.*, 8:337, 1994; Waring et al., *J. Mol. Recog.* 7:109, 1994; Gee et al., *Am. J. Med. Sci.* 304:366, 1992, each of which is incorporated herein by
10 reference) and transcriptional activation domains (see, for example, Triezenberg, *Curr. Op. Gen. Dev.* 5:190, 1995, and references cited therein, incorporated herein by reference) that could be utilized in this read-out assay are known in the art.

Preferred DNA binding entities include the DNA binding domains of helix-
15 turn-helix or homeodomain proteins. Also preferred are the DNA binding domains of hormone receptors. Particularly preferred DNA binding entities include the DNA binding domains of the Ga14, lex A, λ cI, α 2, engrailed proteins. Preferred transcriptional activation domains include those of Ga14 and VP16.

The read-out assay described in this Example and depicted in Figure 32 can
20 be employed in cell droplets to detect homo- or hetero-dimerizing ligands, or compounds that interfere with such ligands. For example, FK506 is a known ligand that forms a complex with a first receptor called FKBP12, which complex can then interact with a second receptor, calcineurin A (Liu et al., *Cell* 66:807, 1991; Griffith et al., *Cell* 82:507, 1995). FK506 therefore can act as a
25 heterodimerizing ligand by mediating interactions between FKBP12 and calcineurin A (see Ho et al., *Nature* 382:822, August 29, 1996; Belshaw et al., *Proc. Natl. Acad. Sci. USA* 93:4604, 1996, each of which is incorporated herein by reference).

In a preferred embodiment of the present invention, a DNA binding moiety
30 that recognizes a site positioned upstream of an essential gene is fused to one of FKBP12 or calcineurin A, and a transcriptional activation domain is fused to the other. Both fusions are expressed in cells. The cells are then mixed with beads to

which FK506 is severably attached, and the cells and beads are introduced into liquid droplets that are displayed on a selective growth medium (i.e., a growth medium on which the essential gene is truly required for cell growth). Some FK506 is released from cells, and the droplets that received FK506-containing
5 beads are detected because the cells within them are able to grow.

FK506 is not the only known heterodimerizing ligand. In fact, there is at least one other known compound (rapamycin) that interacts with FKBP12 and at least one other ligand. Rapamycin competes with FK506 for binding to FKBP12, but does not interact with calcineurin A at all. Instead, rapamycin interacts with
10 the FKBP-rapamycin binding (FRB) domain of FRP/RAFT1 (Chen et al., *Proc. Natl. Acad. Sci. USA* 92:4947, 1995). Thus, a different preferred embodiment of the present invention could be set up in which rapamycin is attached to beads, one of FKBP12 and FRB is attached to a DNA binding entity, and the other is attached to a transcriptional activation domain. A particular version of this embodiment of
15 the invention is depicted in Figure 33.

Specifically, yeast cells are provided that are resistant to rapamycin but that cannot grow on media lacking histidine unless a particular gene **1500** (the *HIS* gene) is expressed. The *HIS* gene **1500** is positioned adjacent a binding site **1400** recognized by a fusion protein that contains a DNA binding domain **1600** fused to
20 FKBP12 **1700**. The cells **700** also contain an FRB(**1800**)/transcriptional-activation-domain(**1900**) fusion. Introduction of such cells into liquid droplets containing beads **600** to which rapamycin **100** is or is not severably linked allows identification of those droplets that contain rapamycin-bound beads because the cells in those droplets will be able to grow on media lacking histidine.

Those of ordinary skill in the art will readily recognize the many
25 permutations and variations of the assay described in this Example that can be employed in accordance with the present invention. For example, the assay system can be set up in cells other than yeast cells; both FK506 (see Ho et al., *Nature* 382:822, August 29, 1996) and rapamycin (Rivera et al., *Nature Medicine*,
30 in press) have been demonstrated to act as heterodimerizers in mammalian cells.

Furthermore, the assay can be applied to the sorts of combinatorial libraries described herein to identify new compounds capable of directing

heterodimerization of any two receptors. That is, when a combinatorial library, instead of FK506 or rapamycin, is attached to the beads, the assay identifies any compounds within the library that direct heterodimerization of whatever receptors have been fused to the DNA binding and activation domains. Similar assays may
5 also be used to identify compounds that direct homodimerization (i.e., that interact with at least two copies of the same receptor).

Moreover, analogous assays may be used to identify compounds that interfere with any receptor-ligand interaction. For example, in the FK506 case, the system is set up as described above except that FK506 is provided in active
10 form (not attached to a bead) and a bead-attached combinatorial library is also provided. If the bead in any particular droplet contains a compound that disrupts the ability of FK506 to interact with either FKBP12 or calcineurin A, the cells in that droplet will die.

Any time a system can be set up so that expression of an essential gene
15 depends upon an interaction between two components (be they protein-chemical; protein-protein; or chemical-chemical), the present invention provides a system by which compounds that disrupt the interaction can be identified. For example, mammalian cells that express the Fas receptor and are grown in media containing the Fas ligand undergo apoptosis unless they also express the *Bcl-2* gene.
20 Accordingly, a transcriptional activation assay analogous to that depicted in Figure 32 can be set up in mammalian cells if the cells are engineered so that expression of *Bcl-2* is dependent upon recruitment of a DNA activation domain to a particular DNA site, which recruitment is in turn dependent on the presence of a "dimerizing" compound.

25 We also note that for each of the assays described in this example, or indeed for any assay that utilizes a hybrid transcriptional regulator comprising a DNA binding entity and a transcriptional regulatory domain, it is equally possible to utilize a transcriptional repression domain (e.g., the amino terminal portion of the yeast $\alpha 2$ protein) rather than a transcriptional activation domain. However,
30 since it is generally considered to be easier from a molecular standpoint to activate gene expression than to repress it, we expect that transcriptional activation screens will be more popular than transcriptional repression screens.

All of the techniques required to create gene fusions and to insert DNA binding sites upstream of reporter genes are known in the art (see, for example, Sambrook et al., *Molecular Cloning: A Laboratory Manual, 2nd ed.*, Cold Spring Harbor Laboratory Press, Cold Spring Harbor, NY, 1989, incorporated herein by reference) and have been used to produce a huge array of different gene fusions that produce fusion proteins and to engineer gene/regulatory sequence arrangements.

Example 10: Detecting Interaction Inhibitors in an Intracellular “Reverse Two-Hybrid” Transcriptional Activation Assay

The present Example describes the use of a read-out assay involving a “reverse two-hybrid” transcriptional activation screen in order to identify test compounds that interfere with associations between interacting factors.

A “reverse two-hybrid” transcriptional activation screen is an assay designed so that interaction between two factors activates transcription of a toxic gene (see, for example, Vidal et al., *Proc. Natl. Acad. Sci. USA* 93:10315, 1996; Vidal et al., *Proc Natl. Acad. Sci. USA* 93:10321, 1996, White, *Proc. Natl. Acad. Sci. USA* 93:10001, 1996, each of which is incorporated herein by reference). The basic system is schematically represented in Figure 34. As can be seen, a first interaction partner **1700a** is linked to a DNA binding entity **1600** that recognizes a regulatory site **1400** operatively linked to a gene **1500a** that, when expressed, produces a product that is toxic to the cell under the growth conditions employed. A second interaction partner **1800a** is linked to a transcriptional activation domain **1900**. When the first **1700a** and second **1800a** interaction partners associate with one another, the transcriptional activation domain **1900** is recruited to the DNA so that the gene **1500a** is activated and the cell dies. In the absence of such association, the cell lives.

The reverse two hybrid system was developed for use in identifying mutations in one or both of the first **1700a** and second **1800a** interaction partners that disrupt their association (Vidal et al., *Proc. Natl. Acad. Sci. USA* 93:10321, 1996). However, researchers have also proposed that the system could be utilized to identify factors that interfere with association of the first **1700a** and second

1800a interaction partners (see, for example, Vidal et al., *Proc. Natl. Acad. Sci. USA* 93:10315). In fact, Vidal et al. have shown that the system can detect the presence of a protein that competes with the second interaction partner 1800a for association with the first interaction partner 1700a, at least when the competing
5 protein is overexpressed (Vidal et al., *Proc. Natl. Acad. Sci. USA* 93:10315). No efforts have previously been made, however, to identify any non-protein factors that can disrupt interaction partner associations.

The inventive droplet assay system provides a format in which a large number of factors can be screened to identify those with an ability to disrupt
10 associations between interaction partners in reverse-two-hybrid systems. In preferred embodiments, the inventive droplet assay system is used to identify small molecule inhibitors of protein-protein interactions, e.g., by screening libraries of chemical compounds (such as combinatorial libraries). However, it will be understood that the inventive assay system can be used to detect inhibitors that
15 disrupt interactions between any two chemical compounds (e.g., proteins, polypeptides, or nucleic acids) that interact with one another.

One difficulty associated with using the standard reverse-two-hybrid screen to identify competitive inhibitors of interaction partner associations is that, unlike the situation in which failure to interact results from mutation of one of the
20 interaction partners so that no association is ever formed, competitive inhibitors exert their effects by disrupting existing associations. Thus, in many contexts (whenever the competing agent is not present in sufficiently high levels at sufficiently early times to completely swamp the interaction), the standard reverse two hybrid system cannot be utilized to detect inhibiting agents because formation
25 of an association between the interaction partners kills the cells before the inhibiting agent has had an opportunity to exert its effect. Of course, where the gene being activated is not essential to cell viability, this problem is less dramatic. Nonetheless, it is often desirable to minimize the extent of association that occurs before the test compound is available to act.

30 We have designed a version of a reverse-two-hybrid screen that avoids this difficulty and allows identification of small molecules that competitively inhibit protein-protein interactions. Our system is schematically represented in Figure 35.

As indicated, a yeast strain is constructed in which both a first fusion protein 2000, comprising a DNA binding entity 1600 linked to a first interaction partner 1700a, and a second fusion protein 2100, comprising a second interaction partner 1800a linked to a transcriptional activation domain 1900, are placed under the control of inducible promoters (i.e., are not expressed unless specific, controllable conditions are present). The strain also contains a toxic reporter gene 1500a.

We have prepared one particular embodiment of this system by constructing a yeast strain, depicted in Figure 36A, in which the first fusion protein comprises the LexA DNA binding domain linked to the cytoplasmic tail of the type I TGF β receptor and the second fusion protein comprises FKBP12 linked to the B42 transcriptional activation domain. The genes for these fusion proteins were both placed under control of the *GALI* promoter, so that neither fusion protein is produced when cells are grown in media containing glucose, but both proteins are produced, after about a three hour delay, when cells are introduced into galactose media. Each of these fusion protein genes was introduced on a plasmid into yeast cells (base strain EGY48, available from Roger Brent) that contained an integrated (at its *ura3* locus) reporter construct comprising the *URA3* gene under control of the *SPO13* promoter and four upstream LexA sites. Use of the *SPO13* promoter ensures that the *URA3* gene is silent unless it is activated from the LexA sites.

The advantage of the strain depicted in Figure 36A for the purposes of identifying molecules that disrupt the interaction between the cytoplasmic tail of the type I TGF β receptor and FKBP12 is that there is an approximately three-hour delay after the strain is introduced into galactose media before the first and second fusion proteins are produced. Accordingly, if the cells are exposed to an inhibiting compound at approximately the same time as they exposed to galactose media, the compound has an opportunity to enter the cells where it can block the interaction before the interaction forms.

We have demonstrated that the strain depicted in Figure 36A is useful for detecting the presence of a compound that disrupt the interaction between the cytoplasmic tail of the type I TGF β receptor and FKBP12 by performing the experiment shown schematically in Figure 36B. Specifically, we exposed the cells

depicted in Figure 36A to galactose media that did or did not contain FK506. FK506 interacts with FKBP12 1800a in a manner that interferes with FKBP12's ability to interact with the cytoplasmic tail of the type I TGF β receptor 1700a. Our results are shown in Figure 378 (Panel A shows scanned images of growing yeast cells; Panel B shows photographs of plates containing yeast cells). As can be seen, increasing concentrations of FK506 in the medium resulted in increasing levels of yeast growth. Controls demonstrated that cells lacking one of the fusion proteins grew well on galactose media with or without FK506, and all cells grew well on media containing glucose.

10 It will be apparent to those of ordinary skill in the art that the system described in this example may readily be employed in the droplet assay of the present invention, and particularly may be employed to screen libraries of compounds for those having an ability to disrupt interactions between FKBP12 and the cytoplasmic tail of the type I TGF β receptor. Moreover, it will be apparent
15 that the system can readily be adapted to detect compounds having an ability to disrupt an association between any two interaction partners. To name but one interesting example, the system may be used to identify compounds that disrupt interactions between cyclin D1 and cdk4. Association of these proteins, which is known to occur in the early G1 phase of the cell cycle, leads to phosphorylation of
20 the retinoblastoma protein (RB) and RB family members, which in turn leads to progression through the cell cycle. Given disruption of this phosphorylation pathway appears to be associated with tumor development (in that many tumors contain mutations of one or more of the genes involved in this pathway, including mutations that result in up-regulation of cyclin D1), it is likely that compounds
25 that specifically inhibit the cyclin D1/cdk4 association will be effective anti-tumor agents.

Example 11: Detecting Ligands in a "Three-Hybrid" Transcriptional Activation Assay

30 This example describes another read-out assay that can be utilized in accordance with the present invention. This assay is related to the transcriptional activation assays described in Example 9, but it encompasses a fundamentally new

idea: combinatorial libraries can be prepared as fusions between the combinatorial compounds and a known other compound. This new concept allows the preparation of combinatorial libraries that are linked to a known ligand (see Example 1 for discussion of linkage to FK506.) The receptor for the known
5 ligand and a second receptor whose target is to be identified can then be made into fusions and employed in a transcriptional activation (or transcriptional repression) assay as described in Example 9. Such assays will identify any compound in the combinatorial library that interacts with the second receptor.

Figure 38 depicts an example of this type of read-out assay that can be
10 utilized in the practice of the present invention. As shown, a library of test compounds **100** is prepared so that each compounds is attached to a bead **600** by means of a severable (in this case, photocleavable) linker **800**. Each test compound **100** is also linked to a known ligand **2200**, such as FK506 or rapamycin, that interacts with FKBP12. Cleavage of the linker **800** releases the
15 test compound as a test compound/FK506 fusion molecule **2300**.

The beads **600** are introduced into liquid droplets along with cells **700** that express two fusion proteins: one in which FKBP12 **1700** is attached to a DNA binding entity **1600** and one in which a selected test receptor **1800** is attached to a transcriptional activation domain **1900**. These cells also contain a "reporter gene"
20 **1500** (typically, as discussed in Example 9, a gene encoding a product that is required for cell growth under the conditions of the assay) and that is not expressed unless the transcriptional activation domain **1900** is recruited to an upstream site **1400** recognized by the DNA binding entity **1600**. The test compound/FK506 fusion molecules **2300** are released from the beads and allowed
25 to enter the cells **700**. In those droplets that receive a test compound **100** capable of interacting with the test receptor **1800**, the reporter gene will be expressed and the cells will grow; cell growth will not occur in other droplets.

Those of ordinary skill in the art will appreciate that the particular embodiment of this screen that is presented in Figure 38 is merely one possible
30 version of the assay. For example, ligands other than FK506 could be fused to the combinatorial library. In principle, any ligand whose receptor is known could be utilized so long as the ligand can successfully be linked to the library molecules

and its receptor can successfully be linked to the DNA binding entity. Similarly, the location of the ligand in the fusion is not critical so long as the test compound is released in association with the ligand and the ligand retains its ability to bind its receptor. Finally, the assay could be "inverted", so that the known receptor is fused to the transcriptional activation domain instead of to the DNA binding entity. As long as expression of the reporter gene is dependent upon association of the DNA binding and transcriptional activation activities, which association does not occur in the absence of a test compound/ligand fusion, the assay will be effective. However, it is expected that this inverted strategy will be less popular than the strategy depicted in Figure 38 because many receptors have inherent transcriptional activation capabilities, so that the DNA binding entity/known receptor fusion might activate expression of the reporter gene even in the absence of the test compound/ligand fusion molecule (and the test receptor/transcriptional activation domain fusion).

15

Example 12: Detecting Ligands and Receptors in a Dual Library, "Three Hybrid" Transcriptional Activation Assay

This Example describes a read-out assay for use in the practice of the present invention that is an extension of the assay described in Example 11. As depicted in Figure 39, the assay is similar to that described in Example 8 except that, instead of being fused to a selected test receptor, the transcriptional activation domain 1900 is fused (via linkage of a cDNA library to a gene encoding the transcriptional activation domain 1900 to a library 1800 of potential receptors. Use of this read-out assay in the droplet system of the present invention allows simultaneous identification of new receptors and ligands that bind to them. As illustrated in Figure 40, both cells and beads are isolated from droplets in which cells grow. The bead tag is sequenced in order to identify the new test compound, and the particular cDNA fused to the transcriptional activation domain coding sequence is sequenced to identify the new receptor. This embodiment of the invention therefore allows simultaneous screening of both a receptor library and a ligand library and thus dramatically expands the number of useful compounds that can be identified.

20
25
30

Example 13: Detecting Compounds that Affect Protein Translocation and/or Subcellular Localization Pathways

This Example describes another type of read-out assay that can desirably be employed in the practice of the present invention. As mentioned above, the droplet system can be desirably utilized with any of a variety of different kinds of readout assays. For example, any assay that results in a change in cell growth or morphology, or localization of expression of a detectable marker, can desirably be utilized. The assay described in the present Example detects subcellular localization of a fluorescent fusion protein within cells.

10 NF κ B is the prototype of a family of transcriptional regulators (sometimes referred to as "Rel" factors) that are sequestered in the cytoplasm through interaction with an inhibitor (for review, see Baeuerle et al., *Cell* 87:13, October 4, 1996, incorporated herein by reference). The inhibitor that interacts with NF κ B is known as I κ B. Exposure of cells to any of a variety of stimuli (such as viral
15 infection, tumor necrosis factor [TNF], LPS, INF- γ , oxygen radicals, etc.) initiates a signaling pathway that results in release of NF κ B from I κ B and translocation of NF κ B into the nucleus, where it regulates expression of genes involved in immune regulation and development. The importance of NF κ B and other Rel factors in regulation of cellular processes involved in malignant
20 transformation, control of apoptosis, immune function, and embryonic development makes identification of test compounds that enhance or interfere with the pathway leading to NF κ B translocation (or translocation of any other Rel factor) particularly desirable.

25 Figure 41 presents a schematic representation of a droplet screen of the present invention in which the readout assay detects NF κ B translocation. As shown, eukaryotic cells (preferably mammalian cells such as Jurkat cells, MG63 cells, NIH 3T3 cells, 293 cells, etc.) are engineered to express NF κ B as a fusion with a detectable protein such as green fluorescent protein. In the absence of an inducing agent such as TNF, the NF κ B/green fluorescent protein fusion is
30 localized in the cytoplasm. Addition of TNF results in translocation of the fusion to the nucleus.

The engineered cells are introduced into liquid droplets along with a library of test compounds, as has been described herein. If no TNF is added to the medium (not shown), test compounds that stimulate NF κ B translocation (identified by the change in localization of green fluorescent protein) are identified; if TNF is added to the medium (Figure 41), test compounds that interfere with NF κ B translocation (e.g., by blocking the TNF receptor, by disrupting the signaling pathway that results in NF κ B translocation, by interacting with NF κ B itself in a way that prevents its translocation, or by other means) are identified.

Those of ordinary skill in the art will readily appreciate that the particular embodiment of this assay that is depicted in Figure 41 is just one possible version of the experiment. For example, a Rel factor other than NF κ B (e.g., NF-AT) could be fused to the green fluorescent protein. Alternatively or additionally, a detectable marker other than green fluorescent protein could be employed. Other modifications will be apparent to those of ordinary skill in the art.

Example 14: Detecting Ligands in Dimerization Assays

The present Example describes readout systems that are related to those described in Examples 9 and 11-12 in the sense that they detect compounds that mediate heterodimerization interactions, but differ from the assays described in those prior Examples because the prior assays all detected heterodimerization that resulted in transcriptional activation. The present invention contemplates that similar dimerization schemes can be constructed so that dimerization results in, for example, detectable protein translocation, change in cell morphology, or other phenomenon.

a) *Intracellular Dimerization Leads to Apoptosis*

For example, one embodiment of a dimerization assay, in which dimerization results in apoptosis, is depicted in Figure 42 (see also Belshaw et al., *Proc. Natl. Acad. Sci. USA* 93:4604, May 1996, incorporated herein by reference). In this embodiment of the assay, FKBP12 is fused to the cytoplasmic tail of a plasma membrane cellular receptor (i.e., a protein that is present in the

plasma membrane of a cell and that, when bound by an extracellular ligand, initiates a signaling pathway within the cell. The term "cellular receptor" therefore refers only to proteins that have particular responses and play particular roles in cells, and can be distinguished from the more general use of the term "receptor", which refers to any protein capable of binding a ligand).

A test receptor (used in the generic sense) is fused to the intracellular domain of the Fas receptor. When a library of combinatorial molecules is screened in an experiment employing the assay depicted in Figure 42, some cells will receive a test compound that is capable of interacting with the test receptor. Simultaneous interactions between i) the test receptor and test compound; and ii) FK506 and FKBP12 recruits the Fas receptor to the cellular receptor. As depicted in Figure 42, multiple copies of FKBP12 are fused to the cellular receptor, so that multiple copies of the Fas receptor are recruited. Dimerization (or multimerization) of the Fas receptor results in production of an apoptotic signal. Accordingly, test compounds that interact with the test receptor are identified because the cells in the droplet that receive them undergo apoptosis, which involves detectable changes in cell morphology.

Those of ordinary skill in the art will recognize that an alternative assay system that would also detect apoptosis resulting from Fas receptor dimerization could be developed, for example, by engineering cells to produce both i) an Fas receptor/FKBP12 fusion and ii) an Fas receptor/target receptor fusion. An FK506-linked combinatorial library could be screened against such cells in a droplet assay of the present invention to identify those compounds that interact with the test receptor because such an interaction would result in Fas dimerization and cell apoptosis. Apoptosis is not induced in the cells in other droplets.

Those of ordinary skill in the art will also recognize that the "test receptor" employed in this assay could equally well be a library of possible receptors, so that the assay could be performed as a dual library screen. Other acceptable modifications will be apparent to those of ordinary skill in the art.

b) *Intracellular Dimerization Leads to Cell Division*

Those of ordinary skill in the art will recognize that an assay similar to that depicted in Figure 42 and described above in section a) can be set up to detect cell
5 division rather than cell apoptosis. Specifically, the ligand receptors (i.e., FKBP12 and the test receptor) can be linked to a mitogenic cellular receptor or receptors instead of to the Fas receptor.

c) *Extracellular Dimerization Leads to Apoptosis or Cell Division*

10 The assays described in sections a) and b) of this Example can be modified so that the ligand receptors (e.g., FKBP12 and the test receptor) are fused to extracellular rather than intracellular domains of the cellular receptors. With such an arrangement, test compounds that interact with the test receptor can be identified even if they are not cell-permeable.

15

d) *Intracellular Dimerization Affects Subcellular Localization*

The present invention can be utilized with a read-out assay in which dimerization results in a detectable change in subcellular localization. For example, cells can be engineered to produce i) a fusion of FKBP12 to a protein or
20 polypeptide that contains a nuclear localization signal; and ii) a fusion of a test receptor to green fluorescent protein. Introduction of such cells into liquid droplets in combination with a library of combinatorial compounds linked to FK506 results in identification of those test compounds that interact with the test receptor (see Figure 42; see also Belshaw et al., *Proc. Natl. Acad. Sci USA*
25 93:4604, May 1996, incorporated herein by reference).

Those of ordinary skill in the art will recognize that this dimerization assay for subcellular localization can also be modified in a variety of different ways. For example, the FKBP12 and test receptor fusions can be reversed (that is, FKBP12 can be fused to the green fluorescent protein and the test receptor can be
30 fused to the nuclear localization signal). Furthermore, the assay may be converted into a dual-library screen as described in Example 12. Other desirable modifications will be apparent to those of ordinary skill in the art.

Example 15: Detecting Ligand Binding *in vitro*

All of the read-out assays discussed thus far involve reactions that take place in or on cells. It is, of course, not required that the droplet assays of the present invention be performed using cellular assays. In fact, most of the
5 transcriptional activation-based assays described above can be performed in the absence of cells. For example, *in vitro* transcription/translation media can be used. DNA constructs containing the reporter gene and genes encoding any fusion proteins can be introduced into droplets of *in vitro* transcription/translation media, along with the test compounds, and activation of the reporter gene construct can be
10 detected. Preferably, the reporter gene encodes a readily detectable protein, such as one that itself is colored (or fluorescent), or that participates in a reaction to produce a colored product. For example, the reporter gene could encode a metal-chelator that competes the metal away from a complex that is fluorescent when it is bound to the metal. In such a system, expression of the reporter gene would
15 result in removal of the metal from the complex and therefore loss of color from the liquid droplet.

Use of such cell-free assays allows detection of test compounds that have the desired receptor-binding activity but that are impermeable to cells. It will be appreciated that such *in vitro* assays can be used for single-library or dual-library
20 screens.

Example 16: Detecting Inhibitors of Receptor-Ligand Interactions

This Example offers an alternative to the scheme described in Example 10 for using the inventive droplet assay system to identify compounds that interfere
25 with receptor-ligand interactions. We note that the term "ligand" as used herein refers to any chemical compound, including a protein, polypeptide, or nucleic acid molecule, that interacts with another compound (typically a protein receptor).

One example of an inhibitory assay of the present invention is to screen for test compounds that disrupt transcriptional activation accomplished in a standard
30 two-hybrid transcriptional regulation system (see, for example, Fields et al. *Nature* 340:245, 1989). A "standard two-hybrid system" is one in which a DNA binding entity is fused to a first interacting partner and a second interacting partner is

fused to a transcriptional activation domain (or, in principle, a transcriptional repression domain. For purposes of simplicity, we explicitly discuss only the use of a transcriptional activation domain but it should be understood that either could be used). A reporter gene whose expression is detectable (e.g., because the cell
5 requires expression to survive under the experimental conditions or because the product is colored or participates in a reaction that gives a colored product, where the term "colored" includes fluorescent) is placed under the control of a regulatory site recognized by the DNA binding domain.

The inhibitory assay described herein can be thought of as an alternative
10 version of a "reverse" two-hybrid system (see Example 10). Basically, a combinatorial library is introduced into liquid droplets that also contain cells (or and *in vitro* transcription/translation system) expressing the two hybrids required for gene activation. Compounds that interfere with the interaction between the first and second interaction partners are detected because the product of the
15 reporter gene is not detectable in the droplets into which they are introduced.

Those of ordinary skill in the art will appreciate that inhibitors of virtually any ligand-receptor interaction can be identified according to this method. To give but one specific example, an assay can be constructed in which i) the Gal4 DNA binding domain is fused to a peptide that interacts with SH3 domains; ii) An SH3
20 domain is fused to a transcriptional activation domain; and iii) the herpes virus thymidylate kinase (TK) gene is placed under control of one or more Gal4 binding sites. Expression of the TK gene is toxic to mammalian cells grown in the presence of gangcyclovir. Accordingly, the screen is performed by introducing cells expressing each of the two fusion proteins and carrying the reporter construct
25 into media droplets containing gangcyclovir. Test compounds are also introduced into the droplets. If a droplet receives a test compound that interferes with the SH3/SH3 binding peptide interaction, then cells in that droplet will not express the TK gene and will survive even though there is gancyclovir in the media. Cells in other droplets will die. This assay involves positive rather than negative selection
30 (that is, selection for cell growth rather than cell death), which is often desirable because it allows for isolation and analysis of the growing cells in addition to the test compounds. However, as described in Example 10, it may be desirable to

arrange the system so that the SH3/SH3 binding peptide interaction is not established until after the test compounds are delivered to the cells. Alternatively or additionally, the assay may be performed so that gangcyclovir is not added to the media until after the test compounds are delivered.

5

Example 17: Detecting Catalysts

The present Example is intended to demonstrate that, in addition to detecting test compounds with desirable biological activities, as is done in the read-out assays described in many of the above Examples, the present invention
10 can be used to detect test compounds with desirable chemical activities.

For example, the inventive droplet assay system may be used to detect catalysts, e.g., for hydrolytic processes. So long as one or more of the reactants and products of the reaction is/are detectable (e.g., is fluorescent), the assay system of the present invention may be used to detect compounds that stimulate
15 production of product or use-up of reactant. Other analytical techniques, as are known in the art, may alternatively be used.

Other Embodiments

The foregoing is merely a description of certain preferred embodiments of
20 the present invention and is intended to exemplify, not limit, its scope. Those of ordinary skill in the art will appreciate that many modifications and variations of the procedures and compounds employed in the above description can be modified without departing from the spirit or scope of the invention.

APPENDIX A

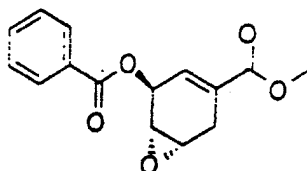
**Methyl (1S,6S)-2R (benzoyl)-7-oxabicycl-[4.1.0]hept-3-ene-4-carboxylate.**

To a 500ml round-bottomed flask equipped with stir bar and purged with N₂ was added Methyl (1S,6S)-2R hydroxy-7-oxabicycl-[4.1.0]hept-3-ene-4-carboxylate (7.95g, 46.8 mmol) in THF (300ml). The solution was cooled to 0°C and treated with benzoic acid (10.25g, 84.2 mmol). To this solution at 0°C was added DEAD in a dropwise manner via syringe. The yellow solution was stirred at 0°C for 1h, warmed to ambient and concentrated in vacuo. The brown residue was diluted with ethyl ether and the solids were filtered. The filtrate was treated with hexane until another precipitate formed, the solids were filtered and the filtrate was concentrated in vacuo. The brown residue was chromatographed on silica gel (1:1 ethyl acetate/hexane) to afford 10g (78%) of purified product. ¹H NMR δ 8.05 (d, 1H), 7.7 (d, 2H), 7.6-7.4 (m, 2H), 6.85 (m, 1H), 5.9 (m, 1H), 3.8 (s, 3H), 3.55 (m, 1H), 3.4 (m, 1H), 3.05 (m, 1H), 2.8 (m, 1H).

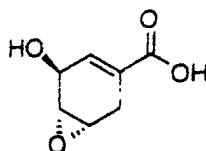
**(1S,6S)-2R-hydroxy-7-oxabicycl-[4.1.0]hept-3-ene-4-carboxylic acid.**

To a 250ml round-bottomed flask equipped with stir bar was added Methyl (1S,6S)-2R (benzoyl)-7-oxabicycl-[4.1.0]hept-3-ene-4-carboxylate (10g, 36.5 mmol) as a solution in THF/H₂O (56ml:56ml). The solution was cooled to 0°C and treated with LiOH (3.2g, 76.7mmol) as a solution in H₂O (30ml). The solution was stirred for 1h, at 0°C and treated with Amberlite IR-120(plus) ion exchange resin until pH 3. The mixture was filtered and concentrated in vacuo. The residue was chromatographed on silica gel (99:1 ethyl acetate/acetic acid) to afford 4.2g (73%) of purified product. ¹H NMR δ 6.7 (m, 1H), 4.5 (m, 1H), 3.4 (m, 1H), 3.2 (m, 1H), 2.8 (m, 1H), 2.6 (m, 1H).

TGR-ANP-ACA-amine Resin

To a suspension of ANP resin (prepared by method of Geysen et al Molecular Diversity 1, 4-12, 1995) (5g, theoretically 1.2 mmol) in NMP (100ml) was added Fmoc aminocaproic acid (2.6g, 7.2 mmol), benzotriazole-1-yl-oxy-tris-pyrrolidino-phosphonium hexafluorophosphate (PyBop) (3.7g, 7.2mmol) and Hunigs base (2.1 ml, 12mmol). The mixture was agitated by N₂(g) for 2h, before

being filtered and washed with NMP (5 x 50ml), CH₂Cl₂ (5 x 50ml), MeOH (5 x 50ml). Coupling was deemed complete by analysis of a semiquantitative ninhydrin test. This material was swelled in NMP (50 ml), filtered and slurried with 20% piperidine in DMF (50ml) for 15 min. and filtered. This step was repeated two times; subsequently the mixture was filtered and washed with NMP (5 x 50ml), CH₂Cl₂ (5 x 50ml), MeOH (5 x 50ml). The resin was dried under high vacuum and used without further modification.

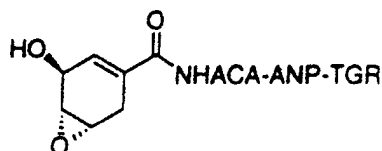

(1S,6S)-2R-hydroxy-7-oxabicyclo-[4.1.0]hept-3-ene-4-ACA-ANP-TGR-carboxamide.

To a slurry of TGR-ANP-ACA-amine resin (5g, theoretically 1.2 mmol) in NMP (50ml) was added (1S,6S)-2R-hydroxy-7-oxabicyclo-[4.1.0]hept-3-ene-4-carboxylic acid (525mg, 3.4 mmol) and PyBop (1.7g, 3.4 mmol) followed by Hunigs base (1.2 ml, 6.7mmol). The mixture was agitated by N₂(g) for 2h. before being filtered and washed with NMP (5 x 50ml), CH₂Cl₂ (5 x 50ml), MeOH (5 x 50ml). Coupling was deemed complete by analysis of a semiquantitative ninhydrin test. A small quantity of resin (50mg) was slurried in CH₃CN /H₂O (7:1) and photolysed under a UV lamp at 365nm. ¹H NMR (CD₃OD) δ 6.3 (m, 1H), 4.5 (m, 1H), 3.4 (m, 1H), 3.3 (m, 3H), 2.6 (m, 2H), 2.2 (dd, 2H), 1.7-1.5 (m, 4H), 1.4 (m, 2H).

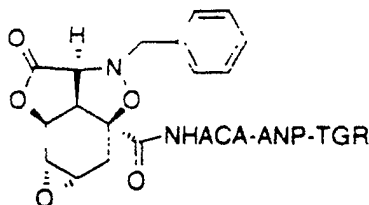

Tetracycline-ACA-ANP-TGR-carboxamide.

To a 2.5ml Bio-rad reaction vessel was placed (1S,6S)-2R-hydroxy-7-oxabicyclo-[4.1.0]hept-3-ene-4-ACA-ANP-TGR-carboxamide (110mg, theoretically 0.03mmol), methyl N-benzylnitron ester (46mg, 0.24mmol), Oteras' catalyst (32mg, 0.03mmol), and 4A molecular sieves. This mixture of solids was slurried in toluene/methylene chloride (9:1). The cloudy suspension was agitated overnight, filtered washed with CH₂Cl₂ (5 x 1ml), THF (5 x 1ml), i-PrOH (5 x 1ml). This protocol was repeated to ensure complete conversion of the starting material. A small quantity of resin (50mg) was slurried in CH₃CN /H₂O (7:1) and photolysed under a UV lamp at 365nm. ¹H NMR (CDCl₃) δ 7.35 (m, 5H), 5.8 (m,

1H), 5.1 (dd, 1H), 4.35 (d, 1H), 4.3 (d, 1H), 4.1 (d, 1H), 3.95 (dd, 1H), 3.55 (dd, 1H), 3.3 (m, 1H), 3.1 (m, 1H), 2.95 (m, 1H), 2.3 (m, 2H), 2.2 (dd, 2H), 1.3-1.1 (m, 6H).

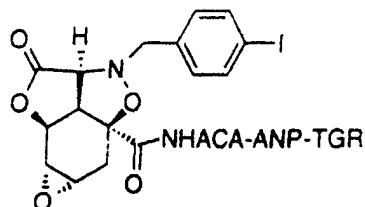

Tetracycline-ACA-ANP-TGR-carboxamide.

To a 2.5ml Bio-rad reaction vessel was placed (1S,6S)-2R-hydroxy-7-oxabicyclo-[4.1.0]hept-3-ene-4-ACA-ANP-TGR-carboxamide (100mg, theoretically 0.027mmol), N-p-iodo-benzylnitron carboxylic acid (82mg, 0.27mmol), 4A sieves (100mg), PyBrop (113mg, 0.24mmol), Hunigs base (50 μ l, 0.27mmol), N,N-dimethyl aminopyridine (16mg, 0.01mmol) in CH₂Cl₂ (1ml). The mixture was agitated overnight, filtered and washed with CH₂Cl₂ (5 x 1ml), NMP (5 x 1ml), THF (5 x 1ml), and i-PrOH (5 x 1ml). A small quantity of resin (50mg) was slurried in CH₃CN /H₂O (7:1) and photolysed under a UV lamp at 365nm. ¹H NMR (CD₃CN) δ 7.68 (d, 2H), 7.12 (d, 2H), 6.1 (brs, 1H), 5.5 (brs, 1H), 5.1 (dd, 1H), 4.3 (d, 1H), 4.2 (d, 1H), 3.9 (d, 1H), 3.7 (dd, 1H), 3.5 (dd, 1H), 3.3 (dt, 1H), 3.1-2.9 (m, 2H), 2.25 (dd, 2H), 2.1 (t, 2H), 1.5 (m, 2H), 1.3 (m, 2H), 1.25 (m, 2H).

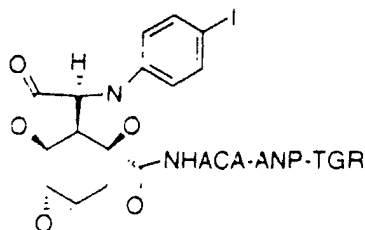

Tetracycline-ACA-ANP-TGR-carboxamide.

To a 2.5ml Bio-rad reaction vessel was placed (1S,6S)-2R-hydroxy-7-oxabicyclo-[4.1.0]hept-3-ene-4-ACA-ANP-TGR-carboxamide (100mg, theoretically 0.027mmol), N-p-iodo-phenylnitron carboxylic acid (79mg, 0.27mmol), 4A sieves (100mg), PyBrop (113mg, 0.24mmol), Hunigs base (50 μ l, 0.27mmol), N,N-dimethyl aminopyridine (16mg, 0.01mmol) in CH₂Cl₂ (1ml). The mixture was agitated overnight, filtered and washed with CH₂Cl₂ (5 x 1ml), NMP (5 x 1ml), THF (5 x 1ml), and i-PrOH (5 x 1ml). A small quantity of resin (50mg) was slurried in CH₃CN /H₂O (7:1) and photolysed under a UV lamp at 365nm. ¹H NMR (CD₃CN) δ 7.68 (m, 4H), , 6.6 (brs, 1H), 6.0 (brs, 1H), 5.1 (dd, 1H), 4.3 (d,

1H), 3.7 (dd, 1H), 3.5 (dd, 1H), 3.3 (dt, 1H), 3.1-2.9 (m, 2H), 2.25 (dd, 2H), 2.1 (t, 2H), 1.5 (m, 2H), 1.3 (m, 2H), 1.25 (m, 2H).

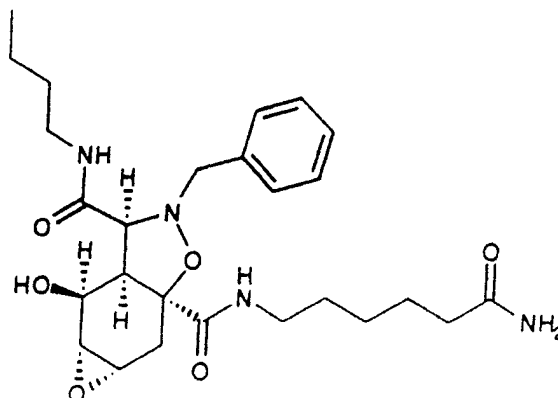

In a Bio-Rad tube was placed resin Tetracycline-ACA-ANP-TGR (60 mg) in dry THF (1ml). To this slurry was added butylamine (80 μ l, 50.0 eq.) and the reaction vessel was capped and shaken (12 h). After which time, the reaction was filtered and washed with MeOH (5X), THF (5X), DMF (5X), and CH₂Cl₂ (5X). The resin was then irradiated in a solution of 7:1 MeCN-H₂O for 30 mins. with a high power 365nm cutoff UV lamp to release the product into solution. LRFABMS (NaI) 503 [M+H], 525 [M+Na]; ¹H NMR (400 MHz) 7.25-7.00 (m, 5H); 6.51 (br s, 1H); 6.05 (br s, 1H); 5.95 (br s, 1H); 5.35 (br s, 1H); 3.99 (d, 1H); 3.71 (d, 1H); 3.65 (d, 1H); 3.46 (dd, 1H); 2.95 (m, 4H); 2.72 (dd, 1H); 2.10 (m, 2H); 1.4-1.0 (m, 10H); 0.7 (m, 3H).

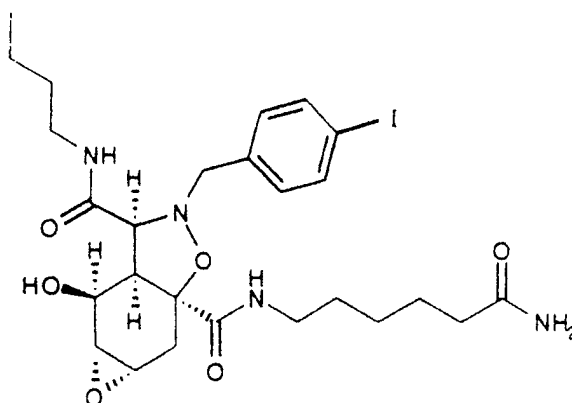

In a Bio-Rad tube was placed resin Tetracycline-ACA-ANP-TGR (60 mg) in dry THF (1ml). To this slurry was added butylamine (80 μ l, 50.0 eq.) and the reaction vessel was capped and shaken (12 h). After which time, the reaction was filtered and washed with MeOH (5X), THF (5X), DMF (5X), and CH₂Cl₂ (5X). The resin

was then irradiated in a solution of 7:1 MeCN-H₂O for 30 mins. with a high power 365nm cutoff UV lamp to release the product into solution. LRFABMS (NaI) 629 [M+H], 651 [M+Na].

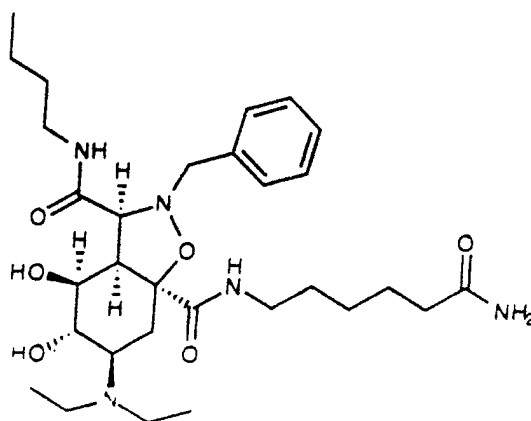

In a Bio-Rad tube was placed resin from the epoxide above 90 mg. in dry PhCH₃. To this solution was added diethylamine (37 ul, 15 eq.) followed by Yb(OTf)₃ (84 mg, 5.0 eq). The slurry was then capped and shaken for 12 h. After which time, the reaction was filtered and washed with MeOH (5X), THF (5X), DMF (5X), and CH₂Cl₂ (5X). The resin was then irradiated in a solution of 7:1 MeCN-H₂O for 30 mins. with a high power 365nm cutoff UV lamp to release the product into solution. LRFABMS (NaI): 576 [M+H]

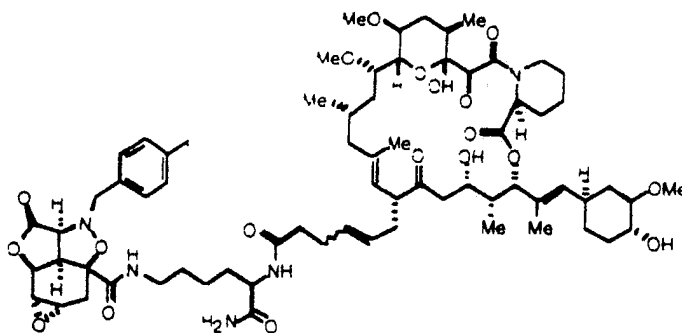

In a Bio-Rad tube was placed resin (50 mg). To this was added FK506 (70mg, 7.0 eq) and 2 mg of the ruthenium benzylidene catalyst. Under Ar, CH₂Cl₂ (500 μl) was added and the tube was allowed to stand in the dark for 24 h. After which time, the reaction was filtered and washed with MeOH (5X), THF (5X), DMF (5X), and CH₂Cl₂ (5X). The resin was then irradiated in a solution of 7:1 MeCN-H₂O for 30 mins. with a high power 365nm cutoff UV lamp to release the product into solution. LRFABMS (NaI): 1450 [M+Na].

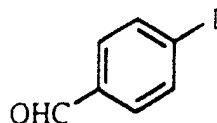

4-iodobenzaldehyde

4-iodobenzoyl chloride (7.99 g, 30 mmol) and triphenylphosphine (15.74 g, 60 mmol) were dissolved in acetone (120 mL) and cooled in an ice bath. Bis(triphenylphosphine)copper borohydride¹ (18.99 g, 31.5 mmol) was added in one portion and the reaction mixture allowed to warm to rt with stirring under N₂. After 2 h, the reaction mixture was filtered to remove tris(triphenylphosphine)copper chloride. The filter cake was washed with Et₂O (50 mL) and the combine filtrates evaporated to dryness. The residue was taken up in Et₂O (200 mL), filtered to remove triphenylphosphine borane, and evaporated to dryness. The residue was redissolved in CHCl₃ (60 mL) and stirred at rt over finely powdered copper chloride (8.91 g, 90 mmol) for 1 h. The mixture was filtered to remove triphenylphosphinecopper chloride and evaporated to give 17.34 g of brown solid. Purification on silica gel (3:1 hexanes CH₂Cl₂) yielded 5.65 g (81% yield) of white solid: ¹H-NMR (CDCl₃) δ 7.59 (d, 2H, J=8.1 Hz), δ 7.92 (d, 2H, J=8.5 Hz), δ 9.96 (s, 1H); ¹³C-NMR (CDCl₃) δ 102.8, 138.4, 130.8, 135.6, 191.4. EI-MS m/z 232. M⁺, mp 70-72°C (uncorr).

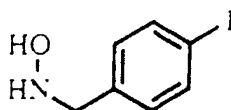

N-(4-iodobenzyl)-hydroxylamine

To a stirred solution of 4-iodobenzaldehyde (5.65 g, 24.3 mmol) in 1:1 MeOH/THF (50 mL) was added a trace of methyl orange and a solution of hydroxylamine hydrochloride (2.11 g, 30.4 mmol) in water (6 mL). The solution was treated with 6N KOH to raise the pH to ≈9 at which point some of the oxime precipitated out. Sodium cyanoborohydride² (1.53 g, 24.3 mmol) was added in one portion acidified to pH=3 with 2N HCl in MeOH. The ruby red mixture was maintained by occasional addition of 2N HCl in MeOH. After 6 h, another eq of sodium cyanoborohydride was added. The addition of water (35 mL) and MeOH (185 mL) resulted in a homogeneous solution and complete conversion. The reaction mixture was evaporated to remove MeOH and THF and taken back up in water (100 mL). The pH was raised to 12 with 6N KOH, causing the

¹ Fleet, G. W. J.; Fuller, C. J.; Harding, P. J. C. *Tetrahedron Lett.* 1978, 1437-1440; Sorrell, T. N.; Spillane, R. J. *Tetrahedron Lett.* 1978, 2473-2474; Fleet, G. W. J.; Harding, P. J. C. *Tetrahedron Lett.* 1979, 975-978; Sorrell, T. N.; Pearlman, P. S. *J. Org. Chem.* 1980, 45, 3449-3451.

² Borch, R. F.; Bernstein, M. D.; Durst, H. D. *J. Am. Chem. Soc.* 1971, 93, 2897-2904.

hydroxylamine to precipitate out of solution. The mixture was transferred to a sep funnel and the flask rinsed with CHCl_3 (200 mL). The organic phase was separated and the aqueous phase was washed with CHCl_3 (4x100 mL). The combined organic extracts were dried (MgSO_4), filtered, and evaporated to yield 5.62 g (93%) of white solid which was used without further purification: $^1\text{H-NMR}$ (CDCl_3) δ 3.90 (s, 2H), δ 4.7-5.4 (br, 2H), δ 7.06 (d, 2H, $J=8.3$ Hz), δ 7.66 (d, 2H, $J=8.3$ Hz); $^{13}\text{C-NMR}$ (CDCl_3) δ 57.4, 93.2, 131.0, 137.4, 137.6; EI-MS m/z 249 (M^+); CI-MS (NH_3) m/z 250 ($\text{M}+\text{H}$) $^-$, 267 ($\text{M}+\text{NH}_4$) $^-$.

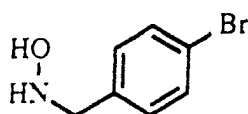

N-(4-bromobenzyl)-hydroxylamine

N-(4-bromobenzyl)-hydroxylamine was made analogously to *N*-(4-iodobenzyl)-hydroxylamine in 97% crude yield: $^1\text{H-NMR}$ (CDCl_3) δ 3.92 (s, 2H), δ 5.5-5.9 (br, 2H), δ 7.18 (d, 2H, $J=8.4$ Hz), δ 7.46 (d, 2H, $J=8.4$ Hz); $^{13}\text{C-NMR}$ (CDCl_3) partial δ 57.4, 130.7, 131.6.

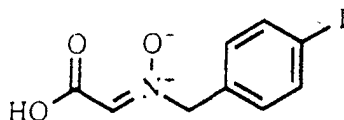

α -carboxy-*N*-(4-iodobenzyl)-nitron

To a stirred solution of *N*-(4-iodobenzyl)-hydroxylamine (4.38 g, 17.6 mmol) in dist. CH_2Cl_2 (500 mL) was added glyoxylic acid monohydrate (1.94 g, 21.1 mmol). The mixture was stirred under N_2 overnight then diluted with CH_2Cl_2 (500 mL) and washed with water (2x200 mL) and brine (1x200 mL). The organic phase was dried (MgSO_4), filtered, and evaporated to yield 4.94 g (92%) of yellow solid. The crude product was purified by stirring in THF (10 mL) for 5 min followed by the addition of 500 mL Et_2O with stirring for 1 h. Filtration and washing with Et_2O (5x100 mL) yielded 3.57 g (67%) of yellow powder: $^1\text{H-NMR}$ (CDCl_3) δ 4.99 (s, 2H), δ 7.17 (d, 2H, $J=8.3$ Hz), δ 7.27 (s, 1H), δ 7.82 (d, 2H, $J=8.4$ Hz); $^{13}\text{C-NMR}$ (CDCl_3) δ 70.2, 96.8, 129.2, 129.8, 131.4, 138.7, 160.5; FAB-MS (NBA/ NaI) 306 ($\text{M}+\text{H}$) $^-$, 328 ($\text{M}+\text{Na}$) $^-$, 350 ($\text{M}+2\text{Na}+\text{H}$) $^-$; (thioglycerol) 304 ($\text{M}+\text{H}$) $^-$; mp 128.5°C (dec $-\text{CO}_2$, uncorr).

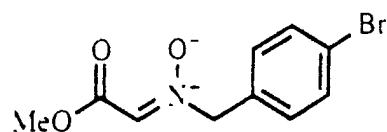

α -carbomethoxy-N-(4-bromobenzyl)-nitronone

To a stirred solution of crude N-(4-bromobenzyl)-hydroxylamine (808.2 mg, 4 mmol) in dist. benzene (10 mL) was added methyl glyoxalate³ (457.9 mg, 5.2 mmol). The reaction mixture was refluxed under a Dean-Stark head for 2 h followed by evaporation of the benzene to yield 1.0798 g (99.6%) of yellow solid which was a 69:31 mixture of isomers: ¹H-NMR (CDCl₃, major isomer) δ 3.81 (s, 3H), δ 5.64 (s, 2H), δ 7.20 (s, 1H), δ 7.41 (d, 2H, $J=8.5$ Hz), δ 7.49 (d, 2H, $J=8.5$ Hz); (minor isomer) δ 3.79 (s, 3H), δ 4.94 (s, 2H), δ 7.09 (s, 1H), δ 7.31 (d, 2H, $J=8.4$ Hz), δ 7.55 (d, 2H, $J=8.4$ Hz).

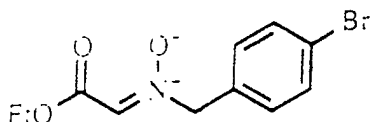

α -carboethoxy-N-(4-bromobenzyl)-nitronone

To a stirred solution of crude N-(4-bromobenzyl)-hydroxylamine (808.2 mg, 4 mmol) in dist. benzene (10 mL) was added a 50% solution of ethyl glyoxalate in toluene (530.9 mg, 5.2 mmol). The reaction mixture was refluxed under a Dean-Stark head for 2 h followed by evaporation of the benzene to yield 1.2402 g (108%) of yellow solid which was a 72:38 mixture of isomers: ¹H-NMR (CDCl₃, major isomer) δ 1.31 (t, 3H, $J=7.2$ Hz), δ 4.26 (q, 2H), δ 5.64 (s, 2H), δ 7.19 (s, 1H), δ 7.42 (d, 2H, $J=8.6$ Hz), δ 7.49 (d, 2H, $J=8.6$ Hz); (minor isomer) δ 1.29 (t, 3H, $J=7.1$ Hz), δ 4.24 (q, 2H), δ 4.93 (s, 2H), δ 7.08 (s, 1H), δ 7.32 (s, 2H, $J=8.4$ Hz), δ 7.55 (s, 2H, $J=8.4$ Hz).

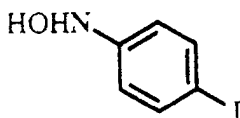

N-(4-iodophenyl)-hydroxylamine

To a stirred solution of 1-iodo-4-nitrobenzene (19.92 g, 80 mmol) in degassed THF (400 mL) was added ammonium chloride (2.14 g, 40 mmol). Degassed water (80 mL) was slowly added with stirring under Ar. Zinc dust (25.6 g, 400

³ Kelly, T. R.; Schmidt, T. E.; Haggerty, I. G. *Synthi* 1972, 544-545.

mmol) was added in one portion and the exothermic reaction mixture stirred vigorously in an Ar atmosphere under a water condenser for 30 min. The reaction mixture was vacuum filtered and the filter cake washed with EtOAc. The combined filtrates were diluted with water until the phases separated. The organic phase was washed with water (2x100 mL) and brine (1x100 mL), dried (MgSO₄), filtered, and evaporated to yield 19.7 g (105%) of orange solid which contained 89% of the desired product by NMR and was used immediately and without further purification: ¹H-NMR (CDCl₃) δ 6.77 (d, 2H, *J*=8.9 Hz), δ 7.56 (d, 2H, *J*=8.8 Hz).

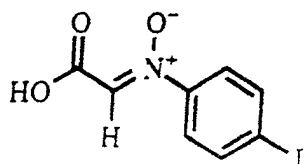

α-carboxy-N-(4-iodophenyl)-nitron

To a stirred solution of the crude *N*-(4-iodophenyl)-hydroxylamine above in dist. CH₂Cl₂ (500 mL) was added glyoxylic acid monohydrate (7.73 g, 84 mmol). The reaction mixture was stirred under N₂ overnight then vacuum filtered. The filter cake was stirred and refiltered several times in a total of 4 L of CH₂Cl₂ for efficient recovery of the product. The combined filtrates were evaporated to yield 21.8 g (94%, 2 steps) of orange powder. The crude product could be purified by stirring in THF (100 mL) for 1 h followed by the addition of Et₂O (1500 mL) and stirring for 1 h. The mixture was vacuum filtered and the filter cake washed with Et₂O (1 L) then allowed to dry. Collection of the filter cake yielded 16.45 g (71%; 2 steps) of light orange powder: ¹H-NMR (CDCl₃) δ 7.50 (d, 2H, *J*=8.9 Hz), δ 7.83 (s, 1H), δ 7.93 (d, 2H, *J*=8.9 Hz); ¹³C-NMR (CDCl₃, partial) δ 99.6, 122.7, 128.0, 139.2, 160.6; CI-MS (NH₃) *m/z* 248 (M-CO₂+H)⁺, 265 (M-CO₂+NH₄)⁺, 292 (M+H)⁻, 309 (M+NH₄)⁻; FAB-MS (NBA/NaI) *m/z* 292 (M+H)⁺, 314 (M+Na)⁺; (glycerol) *m/z* 246 (M-CO₂-H)⁻; (thioglycerol) *m/z* 290 (M-H)⁻, 246 (M-CO₂-H)⁻; mp 130°C (dec -CO₂, uncorr).

Experimental

I. Photocleavable Linker:

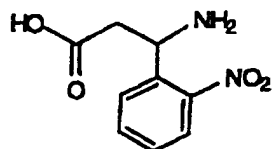

3-Amino-3-(2-nitrophenyl)-propionic acid (Geysen photocleavable linker)

Note: a higher-yielding synthesis of this starting compound was developed by Jim Morken (q.v.)

2-nitrobenzaldehyde (12.21g, 1 eq), malonic acid (8.40g, 1 eq), and ammonium acetate (7.47g, 1.2 eq) were heated in 20 ml EtOH over 30 min to ~80°C. Mixture was held at reflux until gasses ceased to evolve, ~30 min, forming a thick precipitate. Cooled mixture was shaken with 30ml further EtOH and filtered with 200ml Et₂O wash. Precipitate was shaken with 2 liters MeOH and filtered, giving a precipitate of 2.25g. Precipitate was taken up in 40 ml H₂O with 3ml conc. HCl and filtered, and the filtrate adjusted to pH 4.5 with 6N KOH to precipitate the product as a white crystalline solid, 1.93g, 11% yield.

¹H NMR (400 MHz, DMSO-D₆) δ 7.866 (m, 2 H), 7.732 (t, 1H, J = 8.0 Hz), 7.508 (t, 1H, J = 8.0 Hz), 6.65 (br, NH₃⁺), 4.597 (m, 1H), 2.539 (m, 2H, DMSO obscured).

FABMS (glycerol) calcd for [M+H]⁺=211, found LRMS [M+H]⁺=211.

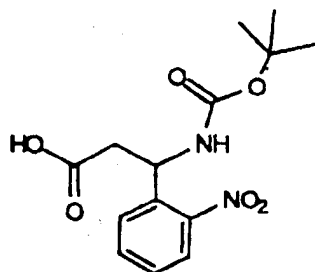

3-*t*-butyloxycarbonylamino-3-(2-nitrophenyl)-propionic acid

3-Amino-3-(2-nitrophenyl)-propionic acid (1.60g, 1 eq) was taken up in minimal 10% Na₂CO₃ solution (~40ml). Di-*t*-butyl-dicarbonate (Boc-anhydride, 2.50g, 1.5 eq) was dissolved in an equal volume of dioxane and added to the aqueous solution above with vigorous stirring. Reaction was continued 30 min, forming a precipitate. Suspension was filtered with wash of 30ml each H₂O and dioxane, and filtrate extracted with 2 x 300ml Et₂O. Aqueous layer was placed in a separatory funnel with 400ml EtOAc followed by addition of 4ml conc. HCl and immediate

shaking to absorb precipitated product into the organic layer. EtOAc was dried over $MgSO_4$ and rotovapped with hexanes to a white solid, 2.19g, 93% yield.

TLC: Rf 0.51 (1% AcOH/EtOAc)

1H NMR (400 MHz, $CDCl_3$) [spectrum shows mixture of cis (minor) and trans (major) BOC isomers] δ 7.908 (d, 1H, J = 8.0 Hz), 7.77-7.67 (m, 3H), 7.503 (t, 1H, J = 8.0 Hz), 5.32 (m, 1H, trans), 5.22 (cis isomer), 2.630 (m, 2H), 1.305 (s, 9H, trans isomer), 1.096 (cis isomer).
FABMS (NBA+Na) calcd for $[M+Na]^+$ =333.1063, found HRMS $[M+Na]^+$ =333.1080.

Coupling of the photocleavable linker to Tentagel

Coupling of the Boc-protected Geysen linker to Tentagel (1 eq) was accomplished using 4 eq PyBop and 5 eq DIEA with 2 eq of the linker in NMP (3h) to give a negative ninhydrin test (starting resin gives a blue color).

Removal of the Boc group was accomplished in neat TFA (2 x 30 min) to give an orange color in the ninhydrin test. Resin was prepared for further coupling by repeated washing with CH_2Cl_2 , NMP, MeOH, MeOH+1% TEA (critical to freebase amine), and finally CH_2Cl_2 .

II. Initial Epoxy-ol Monomer:

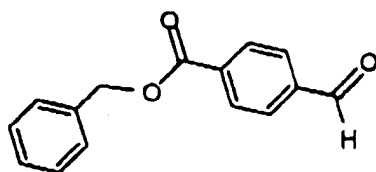

4-formyl benzoic acid benzylester

4-carboxy benzaldehyde (2.60g, 1 eq), 1-(3-dimethylaminopropyl)-3-ethylcarbodiimide hydrochloride (EDC, 5.0g, 1.5 eq), and 50 mg dimethylaminopyridine (DMAP, cat.) were weighed out into a dry flask. To this was added 250ml THF and 2.7ml BnOH (1.5eq). Suspension was stirred under N_2 16h. Solution was decanted from urea residue and liquid rotovapped to a clear oil. This was chromatographed with 10-20% EtOAc/Hex to give the product as a clear oil. After being dried in vacuo 4h. and chilled 24 h at $-20^\circ C$, product crystallizes as a white, waxy solid, 3.32g, 80% yield.

TLC: Rf 0.45 (25% EtOAc/Hex)

1H NMR (400 MHz, $CDCl_3$) δ 10.102 (s, 1H), 8.233 (d, 2H, J=6.8 Hz), 7.954 (d, 2H, J=6.8 Hz), 7.47-7.35 (m, 5H), 5.400 (s, 2H)

EIMS (CH_2Cl_2) calcd for $[M]^+$ =240, found LRMS $[M]^+$ =240.

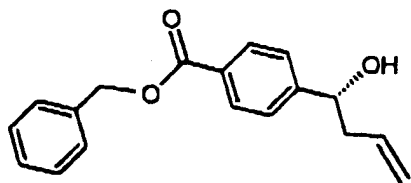

(R)-4-(4-benzyloxycarbonylphenyl)-4-hydroxy-1-butene

(R)-(+)-2,2'-bis(diphenylphosphino)-1,1'-binaphthyl ((R)-(+)-BINAP, 514mg, .075 eq) and silver (I) trifluoromethanesulfonate (Ag-O-Tf, 198mg, .070 eq) were dissolved in 20ml dry THF under N₂ 10 min in the absence of direct light. 4-formyl benzoic acid benzylester (2.64g, 1.0 eq) in 10ml dry THF was added by syringe and the solution stirred 5 min at rt. The solution was cooled to -20°C after which 3.8ml allyltributyltin was added dropwise. The reaction was stirred at -20°C 20h. The completed reaction was warmed to 0°C and 30ml each 1N HCl and 2N KF were added. Biphasic solution was stirred vigorously 20 min, causing a white precipitate to form. The precipitate was filtered off, 10ml each 1N HCl and 2N KF were added, and solution stirred vigorously a further 20 min. The THF layer was separated, the aqueous layer washed with 40ml THF, and the combined organics dried over MgSO₄. The solution was concentrated to ~10ml, precipitated KF was filtered off (EtOAc wash), and filtrate was concentrated to ~2ml. Chromatography with 15-30% EtOAc/Hex gave the product as a clear oil, 2.95g, 95% yield. Derivatization of the alcohol (NMR tube, 5 eq (S)-Mosher's acid chloride, 10 eq. pyridine-D₅, 10h, rt) showed a 27:1 ratio of (R)-(S) to (S)-(S) diastereomers, 93% ee.

Note: the corresponding (S) isomer was synthesized identically except for the substitution of (S)-(-)-BINAP for (R)-(+)-BINAP.

TLC: R_f 0.26 (25% EtOAc/Hex)

¹H NMR (400 MHz, CDCl₃) δ 8.058 (d, 2H, J=8.4 Hz), 7.46-7.32 (m, 7H), 5.787 (m, 1H), 5.364 (s, 2H), 5.180 (m, 1H), 5.151 (m, 1H), 4.811 (m, 1H), 2.509 (m, 2H), 2.098 (d, OH, J=3.2),

CIMS (ammonia) calcd for [M+NH₄]⁺=300.1600, found HRMS [M+NH₄]⁺=300.1607.

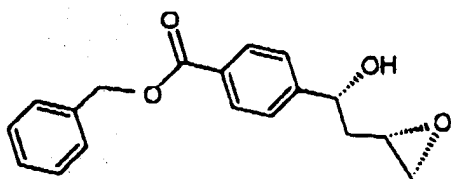

(R)-4-(4-benzyloxycarbonylphenyl)-4-hydroxy-(cis)-1,2-epoxybutane

(R)-4-(4-benzyloxycarbonylphenyl)-4-hydroxy-1-butene (430mg, 1.0 eq) was dissolved in 40ml dry CH₂Cl₂ and chilled to 0°C. Vanadium acetyl acetonate (VO(acac)₂, 22mg, 0.05 eq) was added and solution stirred 10 min. *t*-Bu-OOH solution (5-6M in decane, 0.85 ml, 2.8 eq) was

added at 0°C, and reaction allowed to warm slowly to rt over several hrs. After 16 h, reaction was concentrated to ~2ml and chromatographed with 40-50% EtOAc/Hex to give the product as a clear oil, 327 mg, 72% yield, 3:1 mixture of cis:trans isomer. (Careful chromatography w/ 30-40% EtOAc/Hex could separate cis and trans isomers. Trans isomer runs slightly ahead of its cis counterpart).

TLC: Product: Rf 0.26 (50% EtOAc/Hex) Trans isomer: Rf 0.29 (50% EtOAc/Hex)

¹H NMR (400 MHz, CDCl₃) δ 8.068 (d, 2H, J=8.4 Hz), 7.47-7.32 (m, 7H), 5.361 (s, 2H), 5.040 (m, 1H), 3.036 (m, 1H), 2.774 (dd, 1H, J=4.4, 4.4 Hz), 2.618 (d, OH, J=2.4 Hz), 2.509 (dd, 1H, J=4.4, 2.8 Hz), 2.094 (ddd, 1H, J=14.4, 4.4, 4.4 Hz), 1.820 (ddd, 1H, J=14.4, 8.0, 8.0 Hz)

CIMS (ammonia) calcd for [M+NH₄]⁺=316.1549, found HRMS [M+NH₄]⁺=316.1543.

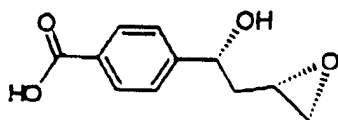

(R)-4-(4-carboxy)-4-hydroxy-(cis)-1,2-epoxybutane

(R)-4-(4-benzyloxycarbonylphenyl)-4-hydroxy-(cis)-1,2-epoxybutane (590mg) was dissolved in 30ml dry THF and 0.30ml triethylamine. Palladium on activated carbon (10% Pd, 35mg) was added and flask stoppered and evacuated by needle until solvent bubbled. A balloon of hydrogen was attached by needle and solution stirred under H₂ 40 min. Completed reaction was filtered through 1cm celite in a cotton-plugged pipette, and clear filtrate concentrated to ~1ml. Chromatography with 2/5/43/50 AcOH/MeOH/EtOAc/CH₂Cl₂ gave a clear oil, which was dried *in vacuo* and rotovapped with CH₂Cl₂/Hex to give the product as a white, waxy solid, 345mg, 84% yield.

TLC: Rf 0.53 (2/6/52/40 AcOH/MeOH/EtOAc/CH₂Cl₂)

¹H NMR (400 MHz, CDCl₃) δ 8.104 (d, 2H, J=8.4 Hz), 7.512 (d, 2H, J=8.4 Hz), 5.079 (dd, 1H, J=8.4, 4.4 Hz), 3.076 (ddd, 1H, J=8.4, 4.4, 4.4 Hz), 2.801 (dd, 1H, J=4.4, 4.4 Hz), 2.534 (dd, 1H, J=4.4, 2.4 Hz), 2.136 (ddd, 1H, J=14.4, 4.4, 4.4 Hz), 1.828 (ddd, 1H, J=14.4, 8.4, 8.4 Hz)

CIMS (ammonia) calcd for [M+NH₄]⁺=226.1079, found HRMS [M+NH₄]⁺=226.1074.

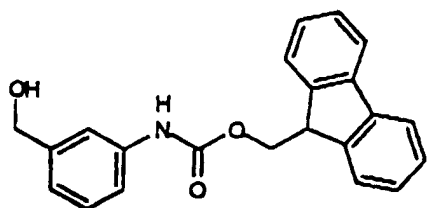
III. Fmoc-Amino-Aldehydes:**3-((9-fluorenylmethoxycarbonyl)-amino)-benzylalcohol**

3-amino-benzylalcohol (1.08g, 1 eq) and Fmoc-succinate (2.65g, 0.9 eq) were stirred in 40ml dry THF with 1.5ml pyridine (2.5 eq) at rt for 24h. Solution was concentrated to ~3ml and chromatographed with 50/50/0.1 EtOAc/Hex/AcOH to give the product as a white solid, 2.0g, 66% yield.

TLC: Rf 0.39 (50/50/1 EtOAc/Hex/AcOH) [product co-spots with Fmoc-Osu; follow disappearance of starting 3-amino-benzylalcohol at Rf 0.11.]

¹H NMR (400 MHz, DMSO-d₆) δ 9.719 (s, br, NH), 7.916 (d, 2H, J = 7.6 Hz), 7.758 (d, 2H, J = 7.6 Hz), 7.430 (m, 3H), 7.353 (m, 3H), 7.201 (t, 1H, J = 7.6 Hz), 6.930 (d, 1H, J=7.6 Hz), 5.182 (t, br, OH), 4.46-4.43 (m, 4H), 4.305 (t, 1H, J = 6.4 Hz).

FABMS (NBA+NaI) calcd for [M+Na]⁺=368, found LRMS [M+Na]⁺=368.

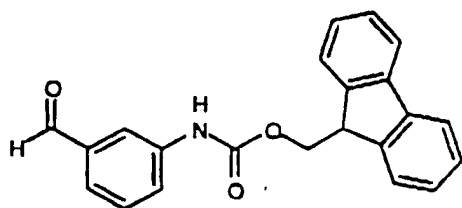
**3-((9-fluorenylmethoxycarbonyl)-amino)-benzaldehyde**

Oxalyl chloride (0.59ml, 1.3 eq) was dissolved in 20ml CH₂Cl₂ and solution cooled to -60°C under N₂. To this was added a solution of 0.81ml DMSO (2.2 eq) in 1ml total volume CH₂Cl₂ and reaction stirred 2 min at -60°C. A solution of 3-((9-fluorenylmethoxycarbonyl)-amino)-benzylalcohol (1.79g, 1 eq) dissolved in 20ml CH₂Cl₂ and minimal DMSO (~2ml) was added dropwise, and the reaction stirred 15 min at -60°C. 3.5 ml triethylamine (5 eq) were added, the reaction was stirred a further 5 min, and then was allowed to warm to rt. 60ml H₂O was added, and the reaction mixture shaken with an additional 50ml CH₂Cl₂. The organic layer was washed with 100ml sat. NaCl solution, dried over MgSO₄, and rotovapped with hexanes to give a white solid, 1.7g, 95% yield.

TLC: Rf 0.68 (50/50/1 EtOH/Hex/AcOH)

$^1\text{H NMR}$ (400 MHz, $\text{DMSO-}d_6$) δ 10.012 (s, br, NH), 9.946 (s, 1H), 8.047 (s, br, 1H), 7.917 (d, 2H, $J = 7.6$ Hz), 7.757 (d, 2H, $J = 7.6$ Hz), 7.726 (d, br, 1H), 7.531 (m, 2H), 7.432 (dd, 2H, $J = 7.6, 7.6$ Hz), 7.339 (dd, 2H, $J = 7.6, 7.6$ Hz), 4.527 (d, 2H, $J = 6.4$ Hz), 4.328 (t, 1H, $J = 6.4$ Hz).

FABMS (NBA+NaI) calcd for $[\text{M}+\text{Na}]^+ = 366.1106$, found HRMS $[\text{M}+\text{Na}]^+ = 366.1090$.

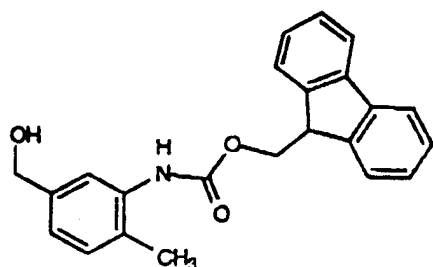

3-((9-fluorenylmethoxycarbonyl)-amino)-4-methyl-benzylalcohol

3-amino-4-methyl-benzylalcohol (966mg, 1 eq) and Fmoc-succinate (2.12g, 0.9 eq) were stirred in 15ml dry CH_2Cl_2 with 2.0ml pyridine (3.6 eq) at rt for 4h, producing a thick white suspension. Suspension was filtered and filtrate rotovapped to dryness, taken up in 30ml CH_2Cl_2 , and re-precipitated with hexanes. Combined precipitates were dried *in-vacuo*, 2.01g total, 89% yield.

TLC: Rf 0.41 (50/50/1 EtOAc/Hex/AcOH)

$^1\text{H NMR}$ (400 MHz, CDCl_3) δ 7.782 (d, 2H, $J = 7.6$ Hz), 7.592 (m, br, 2H), 7.417 (dd, 2H, $J = 7.6, 7.6$ Hz), 7.324 (dd, 2H, $J = 7.6, 7.6$ Hz), 7.26 (s, 1H, CHCl_3 obscured), 7.174 (d, 1H, $J = 7.6$ Hz), 7.081 (d, 1H, $J = 7.6$ Hz), 6.419 (s, br, NH), 4.654 (s, 2H), 4.538 (d, 2H, $J = 6.4$ Hz), 4.289 (t, 1H, $J = 6.4$ Hz), 2.252 (s, 3H).

FABMS (glycerol) calcd for $[\text{M}+\text{H}]^+ = 360$, found LRMS $[\text{M}+\text{H}]^+ = 360$.

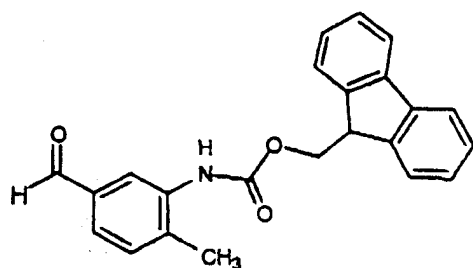

3-((9-fluorenylmethoxycarbonyl)-amino)-4-methyl-benzaldehyde

Oxalyl chloride (0.42ml, 1.7 eq) was dissolved in 10ml CH₂Cl₂ and 10ml THF and solution cooled to -60°C under N₂. To this was added a solution of 0.60ml DMSO (3.0 eq) in 1ml total volume CH₂Cl₂ and reaction stirred 2 min at -60°C. A chilled solution of 3-((9-fluorenylmethoxy carbonyl)-amino)-4-methyl-benzylalcohol (1.0g, 1 eq) dissolved in 10ml THF, 3ml CH₂Cl₂ and 2ml DMSO was added dropwise, and the reaction mixture stirred 20 min at -60°C. 2.5 ml DIEA (5 eq) were added, the reaction was stirred 5 min at -60°C, and then was allowed to warm to rt. 60ml H₂O was added, and the reaction mixture shaken with an additional 100ml CH₂Cl₂. The organic layer was washed with 100ml sat. NaCl solution, dried over MgSO₄, and concentrated to ~ 2ml. Chromatography with 0.5-2.0% MeOH/CH₂Cl₂ gave the product as a white solid, 433mg, 43% yield.

TLC: R_f 0.55 (50/50/1 EtOH/Hex/AcOH); R_f 0.21 (1%MeOH/CH₂Cl₂)

¹H NMR (400 MHz, CDCl₃) δ 9.941 (s, 1H), 8.27 (s, br, NH), 7.782 (d, 2H, J = 8.0 Hz), 7.587 (m, 3H), 7.423 (dd, 2H, J = 8.0, 8.0 Hz), 7.333 (m, 3H), 6.477 (s, br, 1H), 4.594 (d, 2H, J=6.4 Hz), 4.294 (t, 1H, J = 6.4 Hz), 2.325 (s, 3H).

FABMS (NBA+NaI) calcd for [M+Na]⁺ = 380.1263, found HRMS [M+Na]⁺ = 380.1254.

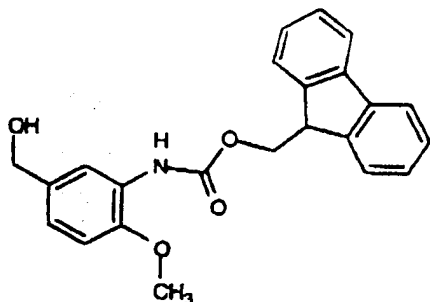

3-((9-fluorenylmethoxycarbonyl)-amino)-4-methoxy-benzylalcohol

3-amino-4-methoxy-benzylalcohol (1.04g, 1 eq) and FMOC-succinate (2.04g, 0.9 eq) were stirred in 40ml dry CH₂Cl₂ with 2.0ml pyridine (3.8 eq) at rt for 32h. Solution was extracted with H₂O, concentrated *in-vacuo* to an oil, taken up in minimal THF and chromatographed with 40/60/1 EtOAc/Hex/AcOH to give the product as a clear oil. Oil was dried *in-vacuo*, then rotovapped with CH₂Cl₂/hexanes to a white foam, 1.72g, 77% yield.

TLC: R_f 0.37 (50/50/1 EtOAc/Hex/AcOH) [product co-spots with FMOC-Osu; follow disappearance of starting 3-amino-4-methoxy-benzylalcohol at R_f 0.11.]

¹H NMR (400 MHz, CDCl₃) δ 8.108 (s, br, NH), 7.790 (d, 2H, J=10.0 Hz), 7.643 (d, 2H, J = 10.0 Hz), 7.423 (dd, 2H, J=10.0, 10.0 Hz), 7.339 (m, 3H), 7.048 (d, 1H, J=11.2 Hz), 6.860 (d, 1H, J=11.2 Hz), 4.616 (s, 2H), 4.520 (d, 2H, J=9.2 Hz), 4.307 (t, 1H, J = 9.2 Hz), 3.895 (s, 3H).

FABMS (glycerol) calcd for [M+H]⁺ = 376, found LRMS [M+H]⁺ = 376.

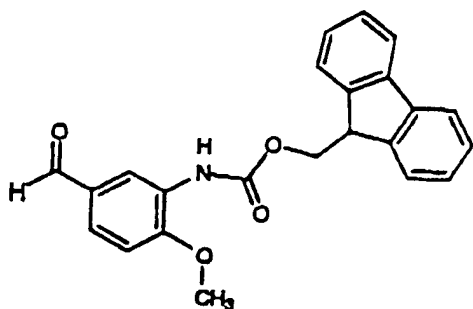

3-((9-fluorenylmethoxycarbonyl)-amino)-4-methoxy-benzaldehyde

Oxalyl chloride (0.70ml, 1.7 eq) was dissolved in 20ml CH₂Cl₂ and solution cooled to -60°C under N₂. To this was added 1.02ml DMSO (3.0 eq) and reaction stirred 2 min at -60°C. A chilled solution of 3-((9-fluorenylmethoxycarbonyl)-amino)-4-methoxy-benzylalcohol (1.72g, 1 eq) dissolved in 10ml CH₂Cl₂ was added dropwise, and the reaction stirred 20 min at -60°C, becoming cloudy. 4.2 ml DIEA (5 eq) were added, the reaction was stirred 5 min at -50°C, and then was allowed to warm to rt. 30ml H₂O was added, the reaction mixture stirred 10 min, and the organic layer separated and washed with 2x100ml sat. NaCl solution. The organic layer was dried over MgSO₄ and rotovapped to an oil, which was dried in vacuo, then rotovapped with hexanes to give a white solid, 1.44g, 84% yield.

TLC: R_f 0.50 (50/50/1 EtOH/Hex/AcOH)

¹H NMR (400 MHz, CDCl₃) δ 9.887 (s, 1H), 8.64 (s, br, NH), 7.794 (d, 2H, J = 7.6 Hz), 7.625 (m, 3H), 7.428 (dd, 2H, J = 7.6, 7.6 Hz), 7.350 (m, 3H), 6.998 (d, 1H, J=8.4 Hz), 4.568 (d, 2H, J=6.4 Hz), 4.315 (t, 1H, J = 6.4 Hz), 3.994 (s, 3H).

FABMS (NBA+NaI) calcd for [M+Na]⁺ = 396.1212, found HRMS [M+Na]⁺ = 396.1217.

IV. Library Synthesis:**Position I: initial epoxy-ol monomer**

Resin: Tentagel, 1 eq, loaded with 3-Amino-3-(2-nitrophenyl)-propionic acid (Geysen photocleavable linker) [see loading conditions above].

Reagents: 1. (R)- or (S)-(cis)-(4-carboxy)-4-hydroxy-1,2-epoxybutane, 1.70 eq in DMF.
2. Diisopropylethylamine, 6 eq
3. HATU coupling reagent, 1.55 eq in DMF

Tumble: 1h, rt.

Wash: 3 x DMF, 5 x CH₂Cl₂.

Analysis: Follow disappearance of orange color on beads by ninhydrin test.

Position II: epoxide opening by secondary amine

Resin: Tentagel, 1 eq, loaded with 3-Amino-3-(2-nitrophenyl)-propionic acid (Geysen photocleavable linker), coupled to position I epoxy-ol.

Reagents: 1. Secondary amine of choice, 25 eq in dry THF.
2. Solution of ytterbium triflate (Yb-(OTf)₃, 5 eq) and secondary amine of choice, (further 25 eq) in dry THF.

Tumble: 24h, rt.

Wash: 3 x THF, 3 x MeOH, 3 x MeOH+1%TEA, 3 x MeOH, 5 x CH₂Cl₂.

Analysis: None.

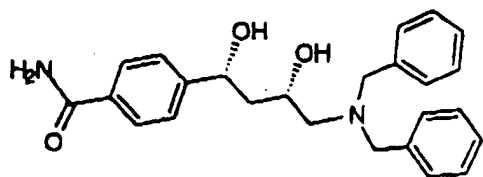
Example:

¹H NMR (400 MHz, DMSO-d₆) δ 7.917 (s, br, NH), 7.820 (d, 2H), 7.36-7.19 (m, 13H), 5.276 (d, OH), 4.678 (m, 1H), 4.541 (d, OH), 3.50-3.39 (m, 4H), 2.331 (d, 2H), 1.802 (m, 1H), 1.560 (m, 1H)

FABMS (glycerol) calcd for [M+H]⁺=405.2178, found HRMS [M+H]⁺=405.2173.

Position III: acetal capping of cis-diol

Resin: Tentagel, 1 eq, loaded with 3-Amino-3-(2-nitrophenyl)-propionic acid (Geysen photocleavable linker), coupled to position I epoxy-ol, epoxide opened by position II amine to generate a cis diol.

Reagents: 1. Fmoc protected amino-aldehyde of choice, 20 eq in dry dioxane.

2. Trimethylsilylchloride (TMS-Cl, 100 eq.)

Tumble: 48h, rt.

Wash: 3 x dioxane, 3 x MeOH, 3 x MeOH+1%TEA, 3 x MeOH, 5 x DMF.

Analysis: None.

Deprotection: removal of Fmoc group

Resin: Tentagel, 1 eq, loaded with 3-Amino-3-(2-nitrophenyl)-propionic acid (Geysen photocleavable linker), coupled to position I epoxy-ol, epoxide opened by position II amine, cis-diol capped with Fmoc protected amino-aldehyde position III.

Reagents: 2 x 20% piperidine in DMF, with 2 x DMF intermediate wash

Tumble: 2 x 15 min, rt.

Wash: 5 x DMF, 3 x MeOH, 3 x MeOH+1%TEA, 3 x MeOH, 5 x CH₂Cl₂.

Analysis: First piperidine/DMF filtrate shows UV-active fulvene spot by TLC (cleavage product of Fmoc). Second piperidine/DMF filtrate shows no UV-active spot.

Free amine may or may not give a positive ninhydrin test (e.g aniline types will be negative).

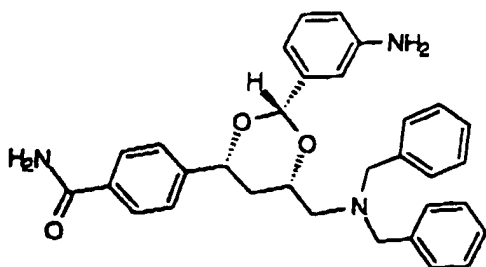
Example:

¹H NMR (400 MHz, CDCl₃) δ 7.965 (s, br, NH), 7.829 (d, 2H), 7.45-7.20 (m, 13H), 6.990 (t, 1H), 6.707 (s, 1H), 6.608 (d, 1H), 6.519 (d, 1H), 5.590 (s, 1H), 5.085 (s, br, NH₂), 4.966 (d, 1H), 4.264 (m, 1H), 3.75-3.55 (m, 4H), 2.646 (m, 1H), 2.55 (m, 1H, DMSO obscured), 1.896 (m, 1H), 1.302 (m, 1H)

FABMS (glycerol) calcd for [M+H]⁺=508, found LRMS [M+H]⁺=508.

Position IV: electrophile capping of free amine

Resin: Tentagel, 1 eq, loaded with 3-Amino-3-(2-nitrophenyl)-propionic acid (Geysen photocleavable linker), coupled to position I epoxy-ol, epoxide opened by position II amine, cis-diol capped with amino-aldehyde position III.

Reagents: 1. 4-dimethylaminopyridine (2 eq) and diisopropylethylamine (50 eq) in CH₂Cl₂
2. electrophile of choice, e.g. acid chloride, (10 eq) in CH₂Cl₂

Tumble: 24h, rt. (may require less time depending on the nature of the amine and electrophile)

Wash: 3 x CH₂Cl₂, 3 x MeOH, 3 x MeOH+1%TEA, 3 x MeOH, 5 x CH₂Cl₂

Analysis: Negative ninhydrin test *if free amine gives a positive ninhydrin test*, otherwise none.

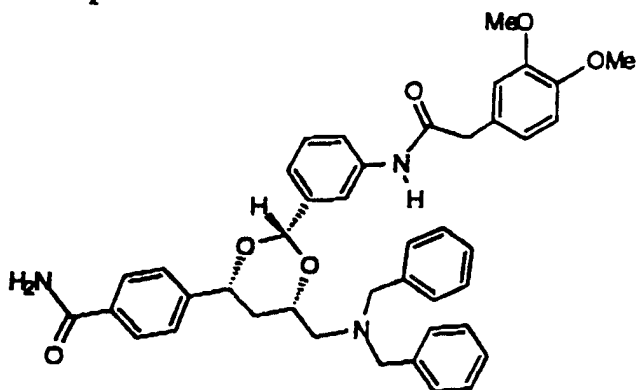
Example:

$^1\text{H NMR}$ (400 MHz, CDCl_3) δ 10.186 (s, NH), 8.006 (s, br, NH), 7.968 (d, 1H), 7.902 (d, 2H), 7.771 (s, 1H), 7.666 (d, 1H), 7.53-7.24 (m, 13H), 7.192 (d, 1H), 6.975 (s, 1H), 6.927 (d, 1H), 6.878 (d, 1H), 5.768 (s, 1H), 5.058 (d, 1H), 4.359 (m, 1H), 3.80-3.70 (m, 8H), 3.65-3.55 (m, 4H), 2.721 (m, 1H), 2.55 (m, 1H, DMSO obscured), 1.959 (m, 1H), 1.387 (m, 1H)
 FABMS (glycerol) calcd for $[\text{M}+\text{H}]^+=686.3230$, found HRMS $[\text{M}+\text{H}]^+=686.3239$.

Photolysis of completed molecules (for NMR/MS analysis)

Beads of interest (generally 2 x 30 mg for an NMR) are placed in two clear 0.7ml eppendorf tubes and tubes filled with acetonitrile. Tubes are sealed and irradiated 1h at 365nm with shaking every 20 min. Mixture is filtered through a pipette w/ cotton plug (acetonitrile wash), and filtrate rotovapped to dryness.

Pyridinium Salts as Synthetic Intermediates for Combinatorial Chemistry

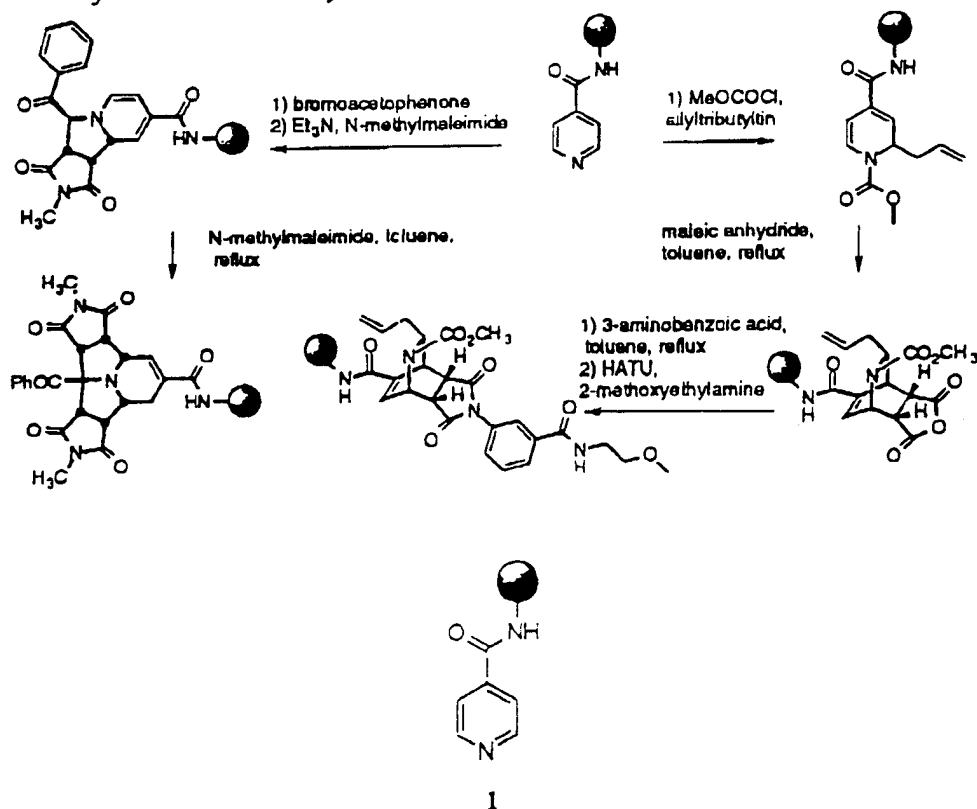

Synthesis of 1

To a 10ml Bio-rad reaction vessel charged with TgrAnpAca-NH₂ resin (1g, 0.24mmol/g) was added isonicotinoyl chloride hydrochloride (1g, 0.24mmol) and methylene chloride (8ml). To this mixture at ambient was added diisopropylethylamine (641ul, 3.6mmol) which solubilized the isonicotinoyl chloride hydrochloride. The mixture was stirred for five minutes when an aliquot was removed, washed successively with CH₂Cl₂ (5 x 2ml), THF (5 x 2ml) and assayed by Kaiser Test. Kaiser test showed the reaction to be complete after 5min. The resin was washed successively with CH₂Cl₂ (5 x 8ml), THF (5 x 8ml), DMF (5 x 8ml), and isopropanol (5 x 8ml). A small sample was photolytically cleaved from the resin and analyzed by mass spectroscopy. MS (CI, ammonia) 236 (M⁺H).

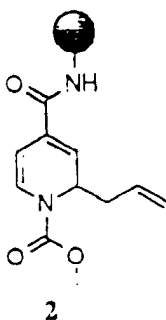

Synthesis of 2

To a 1.5ml Bio-rad reaction vessel charged with 1 (100mg) was added methylene chloride (700ul) and freshly distilled methyl chloroformate (200ul, 2.5mmol). The reaction vessel was sealed and agitated for 2h. The tube was evacuated under nitrogen pressure and the resin was washed with methylene chloride (15ml). The resin was again swelled with methylene chloride (700ul) and treated with freshly distilled allyl tributyltin (310ul, 1mmol). The tube was again sealed and the mixture was stirred for 24h. The resin was then washed successively with CH₂Cl₂ (5 x 8ml), THF (5 x 8ml), DMF (5 x 8ml), and isopropanol (5 x 8ml). A small sample was photolytically cleaved from the resin and analyzed by mass spectroscopy and NMR. ¹H NMR (CDCl₃) δ 6.5-6.8 (br, 1H), 5.35-6.01 (m, 5H), 5.04-5.08 (m, 3H), 4.36 (m, 1H), 3.78 (m, 2H), 3.67 (s, 3H), 3.39 (m, 2H), 2.35-2.5 (m, 2H), 1.58-1.70 (m, 4H), 1.37-1.43 (m, 2H). MS (FAB) M⁺H=336.

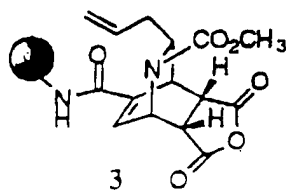
**Synthesis of 3**

To a 1 dram vial charged with resin 2 (200mg, 48umole), was added maleic anhydride (24mg, 48umole) and toluene (700ul). The vial was sealed and placed in a 110°C oven for 48h. The vial was removed, cooled to 23°C and washed successively with CH₂Cl₂ (5 x 8ml), THF (5 x 8ml), DMF (5 x 8ml), and isopropanol (5 x 8ml). A small sample was photolytically cleaved from the resin and analyzed by mass spectroscopy and NMR. ¹H NMR (CDCl₃) δ 5.54-6.0 (br, 3H), 5.07-5.11 (m, 4H), 4.37 (dd, 2H), 3.6-3.9 (br, 7H), 3.33-3.46 (m, 2H), 3.32 (m, 1H), 2.58 (t, 2H), 1.3-1.8 (6H). MS FAB 452 (M+ H₂O) water opened anhydride during photolysis. MS Neg ion (450).

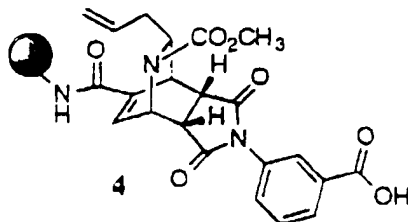
**Synthesis of 4**

To a 1 dram vial charged with resin 3 (150mg, 36umole) was added 3-aminobenzoic acid (25mg, 180umole) and toluene (500ul). The vial was sealed and placed in a 110°C oven for 48h. The vial was removed, cooled to 23°C and washed successively with CH₂Cl₂ (5 x 8ml), THF (5 x 8ml), DMF (5 x 8ml), and isopropanol (5 x 8ml). A small sample was photolytically cleaved from the resin and analyzed by mass spectroscopy. MS FAB 553 (M⁺H), neg ion 551.

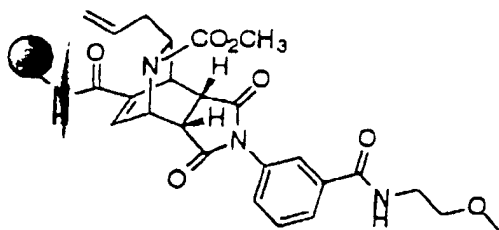

To a bio-rad tube charged with resin 4 (90mg, 21.6umole), HATU (380.21, 108umole) was added methylene chloride (500ul). To this mixture 2-methoxyethylamine (10ul, 108umole) and diisopropylethylamine (38ul, 216umole) were added. The tube was sealed and stirred for 24h. The resin was then washed successively with CH₂Cl₂ (5 x 8ml), THF (5 x 8ml), DMF (5 x 8ml), and isopropanol (5 x 8ml). A small sample was photolytically cleaved from the resin and analyzed by mass spectroscopy MS (FAB) 610 (M⁺H), MS (FAB + NaI) 632 (M⁺Na).

APPENDIX 5

Nitrogen Deprotection: Further Functionality

Removal of the Teoc N-protection reveals a homo-allylic amine, subsequent tandem acylation and (3+2) cycloaddition yield a polycyclic alkaloid.

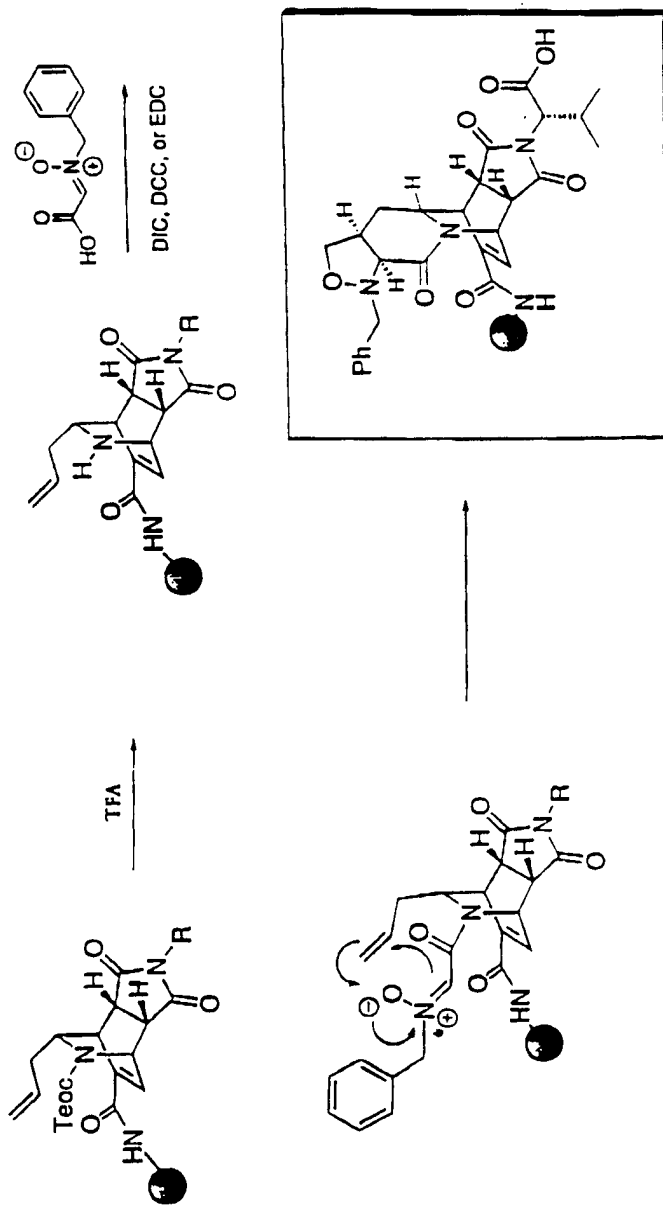

Acylation of the Unmasked Hydroxyamide

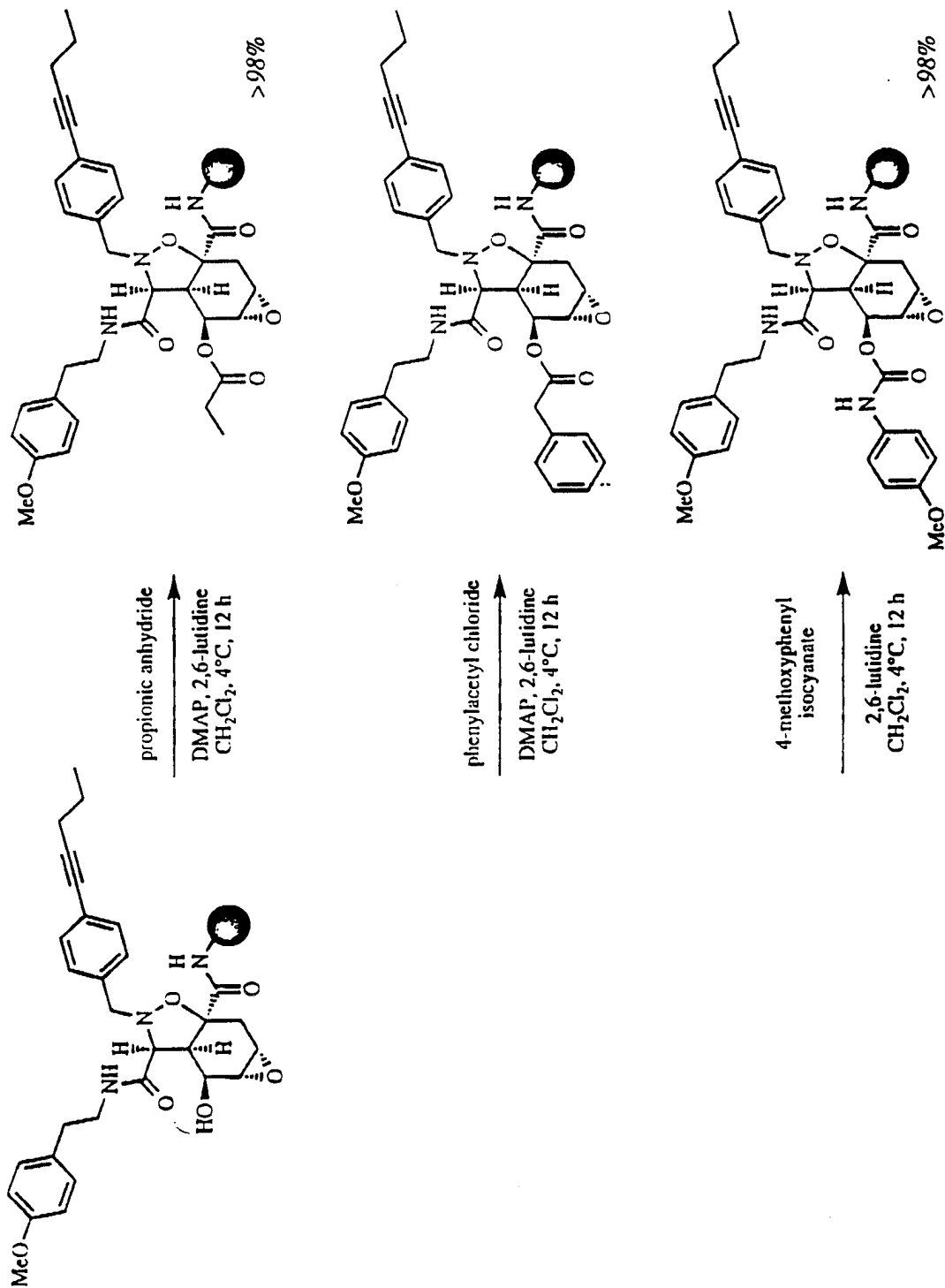

Rhodium-Catalyzed Hydroacylation and Azide Cycloaddition at the Aryl Alkyne

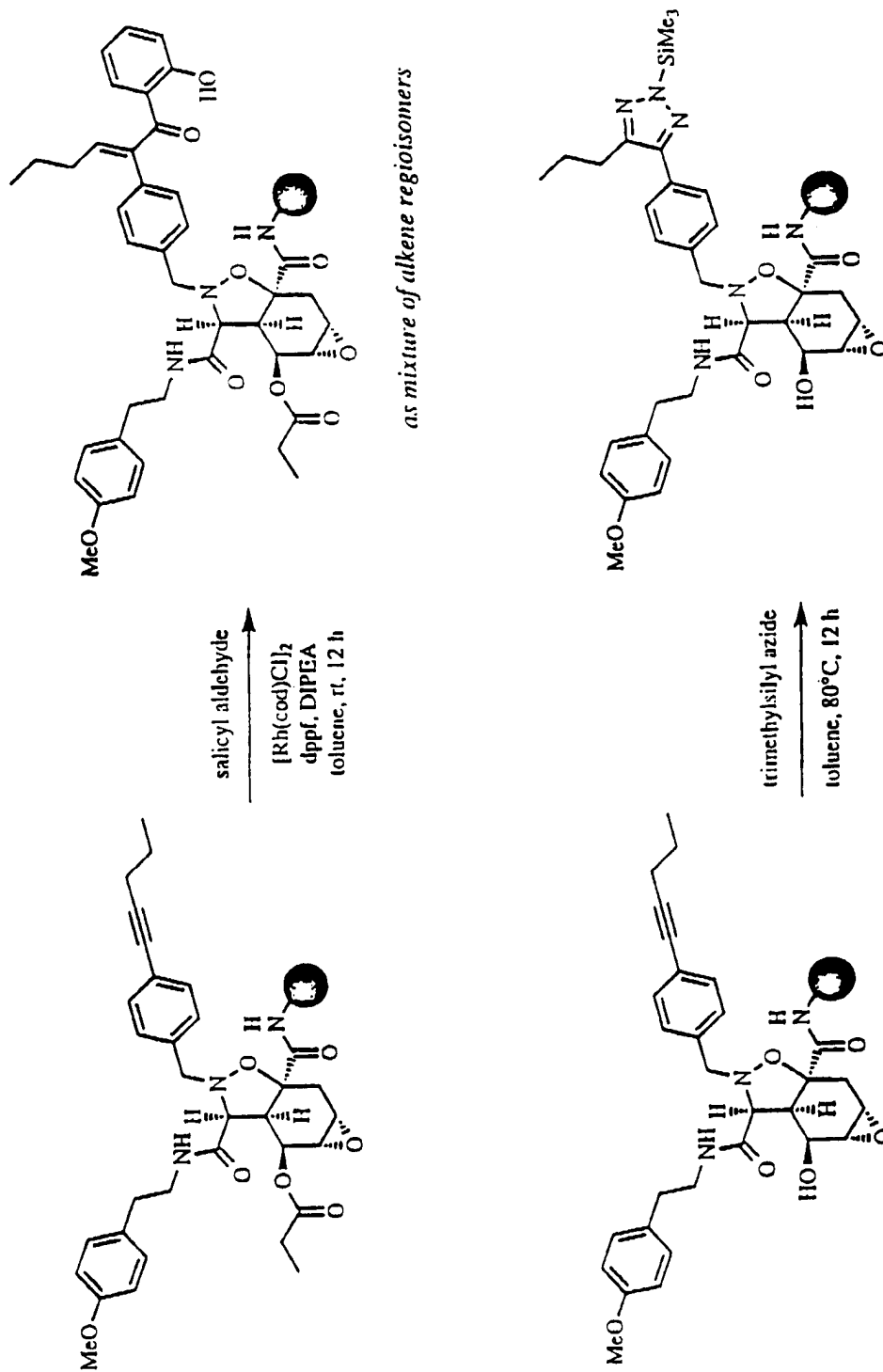

Synthetic Plan for Generation of 46.5 Million Complex Molecules

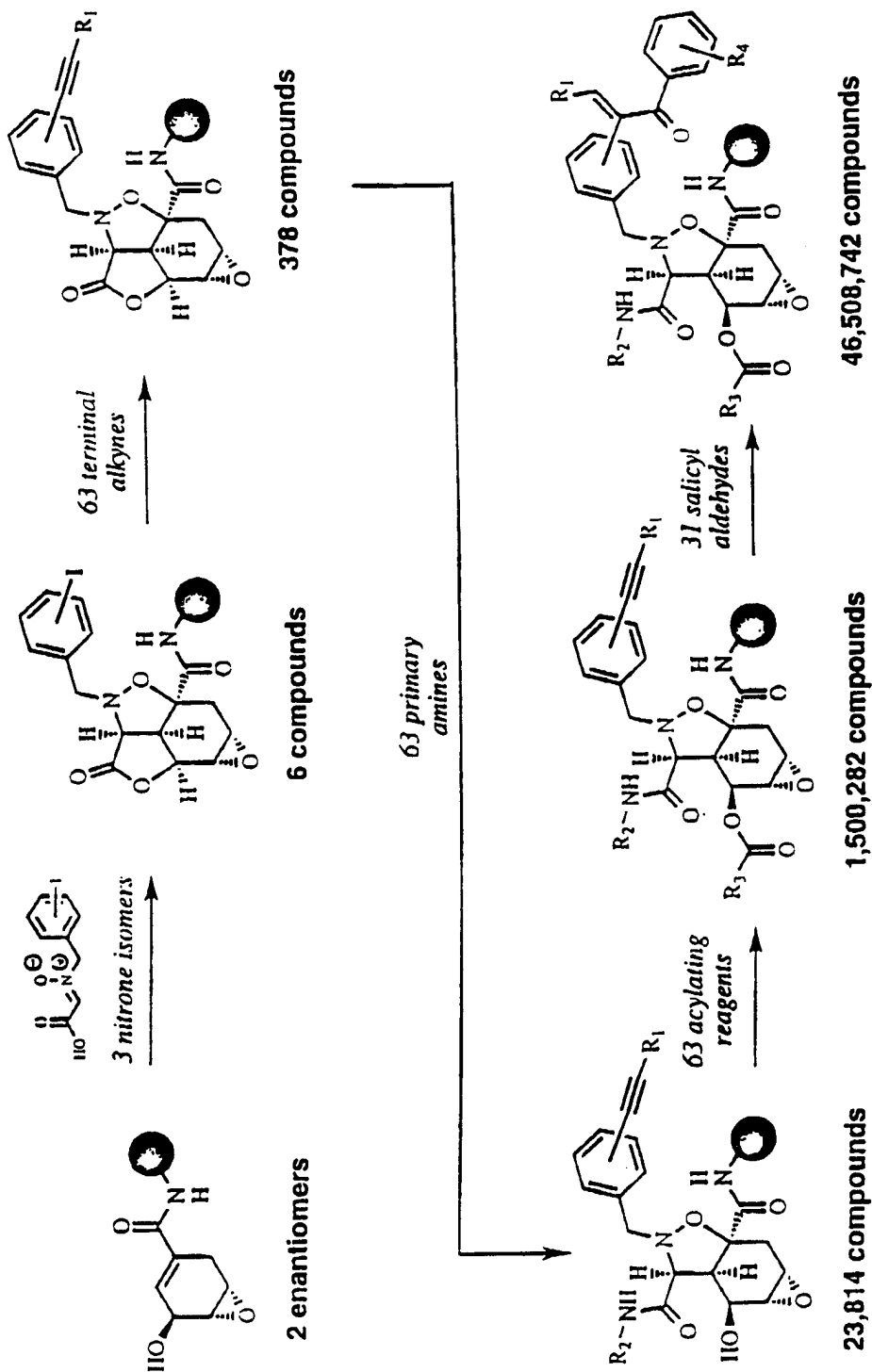

Claims

1

2 1. A composition comprising:
3 a display surface;
4 a plurality of liquid droplets the display surface;
5 at least one chemical compound within at least one liquid droplet of said
6 plurality of liquid droplets.

7

8 2. The composition of claim 1 wherein the display surface is selected to be
9 compatible with cell viability.

10

11 3. The composition of claim 1 wherein the display surface is selected to
12 minimize droplet evaporation.

13

14 4. The composition of claim 3 wherein the display surface is a coverable petri
15 dish.

16

17 5. The composition of claim 11 wherein the display surface is selected or
18 utilized so that each droplet is substantially immobilized on the surface.

19

20 6. The composition of claim 5 wherein the display surface contains wells or
21 pockets.

22

23 7. The composition of claim 6 wherein the wells or pockets are formed in a
24 predetermined array.

25

26 8. The composition of claim 7 wherein the wells or pockets are formed by
27 photolithography.

28

29 9. The composition of claim 1 wherein the display surface is formed from a
30 material selected from the group consisting of plastic, glass, or membranes.

31

- 1 10. The composition of claim 8 wherein the display surface is formed from a
2 membrane comprising a polymer membrane.
3
- 4 11. The composition of claim 10 wherein the polymer membrane is selected
5 from the group consisting of polymethyl methacrylate, polyurethane, and PDMS
6 polymer.
7
- 8 12. The composition of claim 1 wherein the at least one chemical compound
9 comprises several chemical compounds and those liquid droplets that contain a
10 chemical compound contain on average one chemical compound.
11
- 12 13. The composition of claim 1 or claim 12 wherein each chemical compound
13 comprises a plurality of individual molecules of identical chemical structure.
14
- 15 14. The composition of claim 13 wherein each chemical compound is attached
16 to a support.
17
- 18 15. The composition of claim 14 wherein each chemical compound is severably
19 attached to a support.
20
- 21 16. The composition of either one of claims 14 and 15 wherein the at least one
22 support comprises chemical compounds and those liquid droplets that contain a
23 support contain on average a plurality of supports.
24
- 25 17. The composition of either one of claims 14 and 15 wherein the support
26 comprises a polymer material.
27
- 28 18. The composition of claim 17 wherein the polymer material is selected from
29 the group consisting of polydextran, sephadex, polystyrene, polyethylene glycol,
30 polyacrylamide, cellulose, and combinations thereof.
31

- 1 19. The composition of either one of claims 14 and 15 wherein the support is
2 selected from a material from the group consisting of glass, latex, acrylic, ceramic
3 supports, or an encapsulation matrix.
4
- 5 20. The composition of claim 1 wherein the liquid droplets are stochastically
6 arrayed on the display surface.
7
- 8 21. The composition of claim 1 wherein the liquid droplets are arrayed non-
9 stochastically on the display surface.
10
- 11 22. The composition of either one of claims 20 and 21 wherein the composition
12 is arranged and constructed such that substantially no diffusion of chemical
13 compounds between droplets occurs.
14
- 15 23. The composition of either one of claims 20 and 21 wherein each liquid
16 droplet has substantially the same volume.
17
- 18 24. The composition of either one of claims 20 and 21 wherein each droplet
19 contains approximately 50-100 nL of liquid.
20
- 21 25. A method of detecting a chemical compound having a desired activity, the
22 method comprising steps of:
23 providing a collection of chemical compounds of different structure;
24 introducing the chemical compounds into liquid droplets so that those
25 droplets that contain a compound contain, on average, one compound;
26 assaying the liquid droplets to detect those that contain a compound having
27 a desired activity; and
28 identifying the compound having desired activity.
29
- 30 26. The method of claim 25 wherein the step of providing a collection of
31 chemical compounds comprises synthesizing a collection of chemical compounds

1 derived from a tetracyclic system synthesized from solid-phase-bound epoxyol
2 templates and nitrones with an esterification promoter.

3

4 27. The method of claim 25 wherein the step of providing a collection of
5 chemical compounds comprises synthesizing a collection of chemical compounds
6 derived from a dioxalane system.

7

8 28. The method of claim 25 wherein the step of providing a collection of
9 chemical compounds comprises synthesizing a collection of chemical compounds
10 derived from a pyridinium salt.

11

12 29. The method of claim 25 wherein the step of providing a collection of
13 chemical compounds comprises constructing the library of chemical compounds
14 using the parallel synthesis technique.

15

16 30. The method of claim 25 wherein the step of providing a collection of
17 chemical compounds comprises constructing the library of chemical compounds
18 using the split and pool technique.

19

20 31. The method of claim 26 wherein the tetracyclic system is subjected to
21 several different chemical reactions to produce a library of compounds.

22

23 32. The method of claim 31 wherein the tetracyclic system is subjected to
24 reactions with nucleophiles at the γ -lactone function of the tetracyclic system.

25

26 33. The method of claim 32 wherein the nucleophile is selected from the group
27 consisting of primary amines, secondary amines, Grignard reagents, organocerium
28 reagents, organolithium reagents, or organoaluminum reagents.

29

30 34. The method of claim 31 wherein the tetracyclic system is subjected to
31 reactions with electrophiles at the free hydroxyl.

32

1 35. The method of claim 34 wherein the electrophile is selected from the group
2 consisting of isocyanates, acid chlorides, sulfonyl chlorides, alkyl halides, and
3 ketenes.

4

5 36. The method of claim 31 wherein the tetracyclic system is subjected to
6 reaction with nucleophiles under ytterbium catalysis at the epoxide.

7

8 37. The method of claim 36 wherein the nucleophile is selected from the group
9 consisting of amines or silyl enol ethers.

10

11 38. The method of claim 26 wherein the tetracyclic system is functionalized at
12 the iodide in the aromatic ring.

13

14 39. The method of claim 38 wherein the tetracyclic system is functionalize at
15 the iodide in the aromatic ring with a group selected from the group consisting of
16 amines, amides, acetylenes, alkenes, aromatic rings, and heterocycles.

17

18 40. The method of claim 38 or 39 wherein the functionalization is
19 accomplished using palladium-catalized chemistry.

20

21 41. The method of claim 26 wherein one of the sites on the tetracyclic system
22 is functionalized with a ligand so that every molecule in the library has the same
23 linkage.

24

25 42. The method of claim 25 wherein the step of providing a collection of
26 chemical compounds comprises providing a collection of chemical compounds,
27 each of which is linked to a solid support.

28

29 43. The method of claim 42 wherein the step of providing a collection of
30 chemical compounds comprises providing a collection of chemical compounds,
31 each of which is severably linked to a solid support.

32

- 1 44. The method of claim 42 wherein the step of providing a collection of
2 chemical compounds comprises providing a collection of chemical compounds,
3 each of which is linked to a solid support so that a plurality of molecules of the
4 compound are linked to the support.
5
- 6 45. The method of claim 44 wherein each chemical compound is attached to a
7 support that contains information enabling identification of the chemical structure
8
- 9 46. The method of claim 44 wherein the step of identification comprises
10 interpretation of the information attached to the chemical support.
11
- 12 47. The method of claim 45 wherein the information enabling identification of
13 the chemical structure is provided by an encoded tag on the support.
14
- 15 48. The method of claim 44 wherein each solid support has approximately the
16 same number of molecules attached thereto.
17
- 18 49. The method of claim 43 wherein the step of providing a collection of
19 chemical compounds comprises providing a collection of chemical compounds,
20 each of which is separably linked to a solid support by means of a linker that is
21 sensitive to enzymatic cleavage, chemical cleavage, exposure to an acidic
22 environment, exposure to a basic environment, exposure to a reducing
23 environment, or exposure to radiation of appropriate wavelength.
24
- 25 50. The method of claim 49 wherein the step of providing a collection of
26 chemical compounds comprises providing a collection of chemical compounds,
27 each of which is separably linked to a solid support by means of a photosensitive
28 linker.
29
- 30 51. The method of claim 50 wherein the step of providing a collection of
31 chemical compounds comprises providing a collection of chemical compounds,
32 each of which is separably linked to a solid support by means of a photosensitive

1 linker so that exposure of the support to approximately 15 seconds of ultraviolet
2 radiation releases a sufficient amount of compound to achieve a concentration of
3 about 50-100 nM in an approximately 100 nL droplet.

4

5 52. The method of claim 25 wherein the step of introducing comprises
6 introducing the chemical compounds into liquid droplets of substantially identical
7 volumes.

8

9 53. The method of claim 52 wherein the step of introducing comprises:
10 combining the collection of chemical compounds with a liquid to form a
11 mixture;
12 applying the mixture to a display surface containing wells of substantially
13 uniform size so that the liquid droplets are formed in the wells.

14

15 54. The method of 52 wherein the step of applying comprises applying by a
16 wetting/dewetting procedure.

17

18 55. The method of 53 wherein the step of applying comprises applying to a
19 display surface produced by photolithography.

20

21 56. The method of claim 42 wherein the step of assaying comprises steps of:
22 introducing cells into the droplets before, after, or simultaneously with the
23 step of introducing the compounds into the droplets;
24 allowing the compounds to enter the cells; and
25 detecting a change in the cells, the change being indicative of the desired
26 activity.

27

28 57. The method of claim 56 wherein the change is selected from the group
29 consisting of cell growth, cell death, changes in morphology, changes in
30 expression of a detectable marker, and changes in localization of a detectable
31 marker.

32

1 58. The method of claim 42 wherein the step of assaying comprises detecting
2 an ability to catalyze a chemical reaction.

3

4 59. The method of claim 49 wherein:
5 the step of providing a collection of chemical compounds comprises
6 providing a collection of chemical compounds, each of which is linked to a
7 common ligand so that cleavage of the separable linker releases a hybrid molecule
8 containing a chemical compound linked to the common ligand; and
9 the step of assaying comprises performing an assay that detects activity of
10 the common ligand and the chemical compound simultaneously.

11

12 60. The method of claim 49 wherein the step of assaying comprises screening
13 the collection of chemical compounds for ability to interact with a collection of
14 receptors.

15

16 61. The method of claim 25 wherein the step of introducing comprises
17 displaying liquid droplets in a substantially stochastic arrangement on a display
18 surface.

19

20 62. The method of claim 61 wherein the step of displaying comprises
21 combining the chemical compounds with liquid in a display device that distributes
22 the liquid as droplets on the display surface.

23

24 63. The method of claim 62 wherein the step of displaying comprises adjusting
25 the size of the droplets by a mechanism selected from the group consisting of:
26 altering the rate at which the liquid is ejected from the delivery device, altering the
27 extent of air flow within the device, altering the size of the aperture through which
28 the droplets are delivered, altering the surface tension of the liquid and altering the
29 viscosity of the liquid.

30

31 64. The method of claim 62 wherein surface tension and viscosity are altered
32 by selecting a liquid that inherently has the desired viscosity.

1

2 65. The method of claim 62 wherein surface tension and viscosity are altered by
3 providing an additive.

4

5 66. The method of claim 62 wherein the step of displaying comprises
6 depositing droplets in series.

7

8 67. The method of claim 62 wherein the step of displaying comprises
9 depositing droplets simultaneously.

10

11 68. The method of claim 67 wherein the step of displaying comprises
12 depositing the droplets with a device comprising a multi-tip pipette.

13

14 69. The method of claim 25 wherein the step of introducing comprises
15 displaying the liquid droplets in a substantially non-stochastic arrangement on a
16 display surface.

17

18 70. The method of claim 69 wherein the step of displaying comprises forming
19 droplets on a display surface containing wells of pre-determined configuration and
20 arrangement.

21

22 71. The method of claim 70 wherein the step of forming comprises applying by
23 a wetting/dewetting procedure.

24

25 72. The method of claim 70 wherein the display surface containing wells of
26 pre-determined configuration and arrangement is prepared by photolithography.

27

28 73. The method of claim 70 or 72 wherein the wells are dimensioned so as to
29 hold approximately 50 nL of liquid.

30

1 74. A library of combinatorial molecules in which each member of the library
2 is linked to a common ligand, the common ligand being characterized by an ability
3 to bind to a receptor.

4

5 75. A method of detecting a chemical compound having a desired activity, the
6 method comprising steps of:

7 providing a collection of chemical compounds of different structure;

8 introducing the chemical compounds into liquid droplets so that those

9 droplets that contain a compound contain, on average, more than one compound;

10 assaying the liquid droplets to detect those that contain a compound having
11 a desired activity; and

12 identifying the compound having desired activity.

13

14 76. The method of claim 75 wherein the step of providing a collection of
15 chemical compounds comprises providing a collection of chemical compounds,
16 each of which is linked to a solid support.

17

18 77. The method of claim 76 wherein the step of providing a collection of
19 chemical compounds comprises providing a collection of chemical compounds each
20 of which is linked to a solid support so that a plurality of molecules of the
21 compound are linked to the support.

22

23 78. The method of claim 75 wherein the liquid droplets contain on average
24 more than one support.

25

26 79. The method of claim 78 wherein each support contains substantially the
27 same number of molecules per support.

1 / 4 5

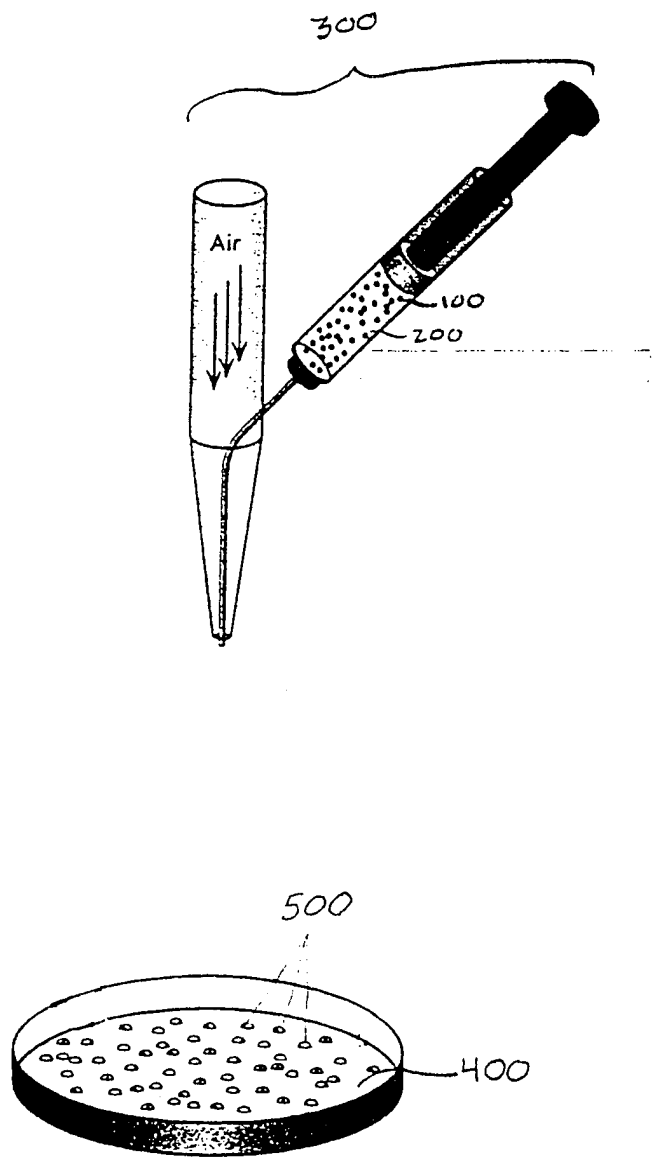

FIGURE 1A

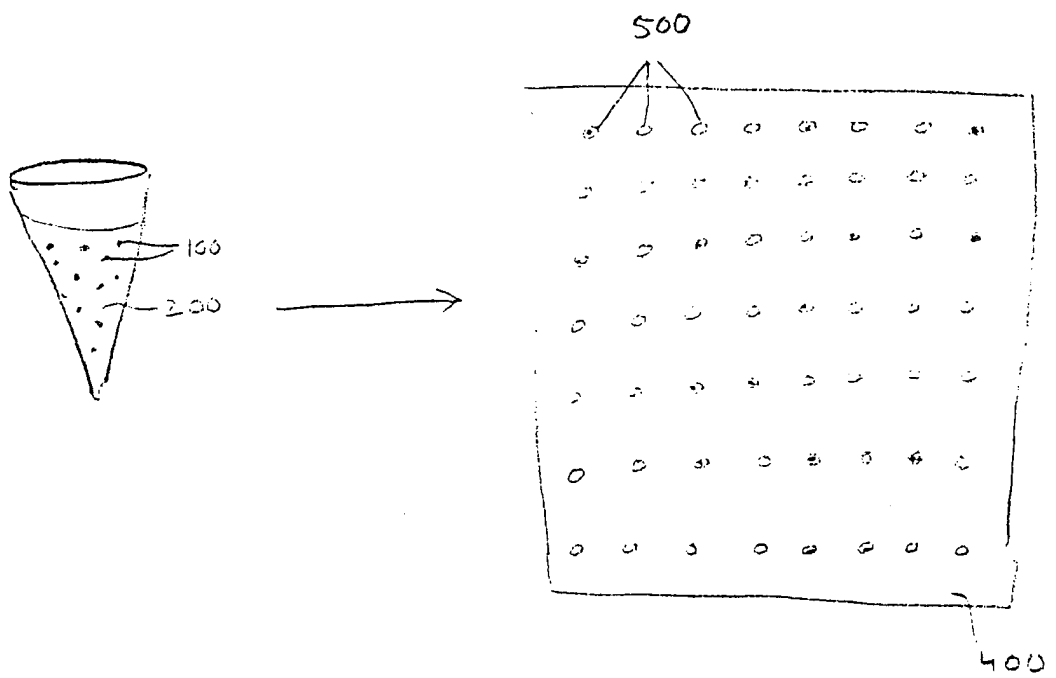

FIGURE 1B

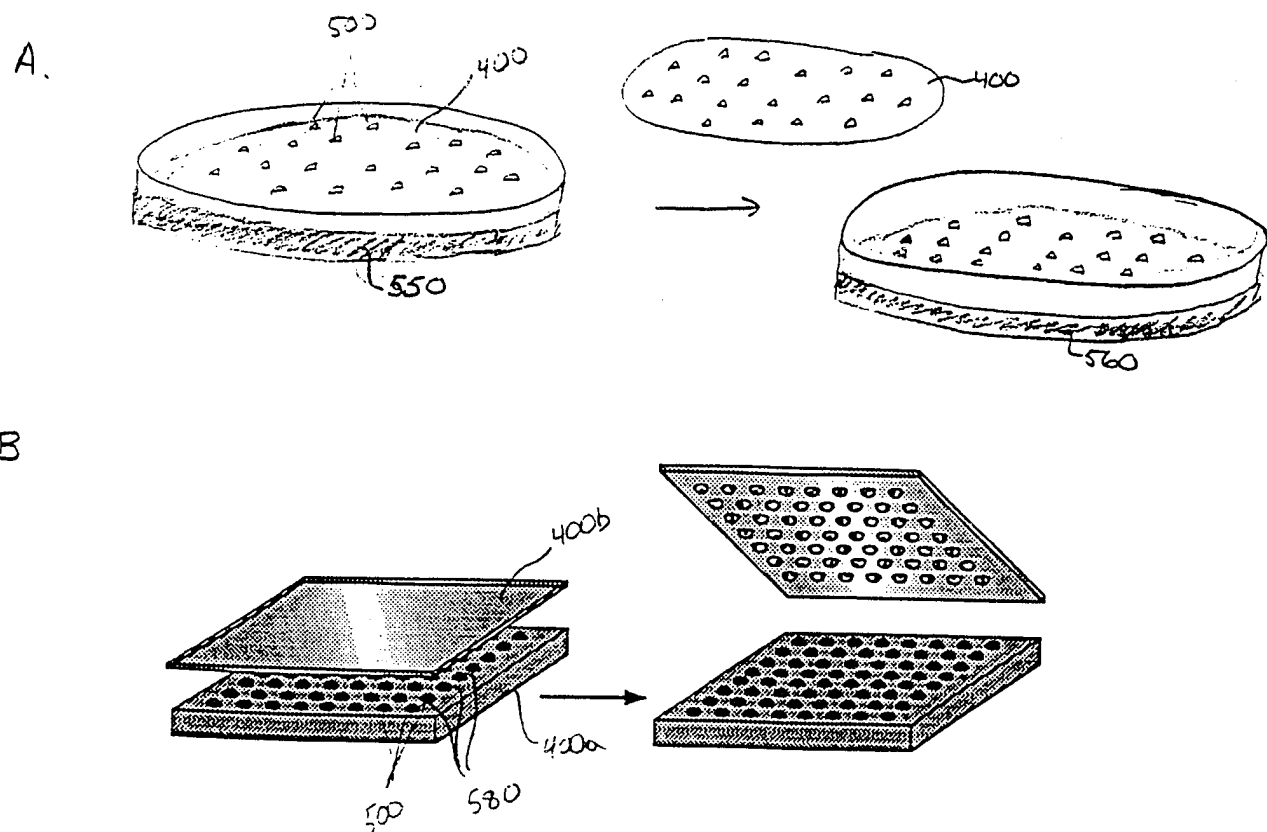

FIGURE 2

4 / 4 5

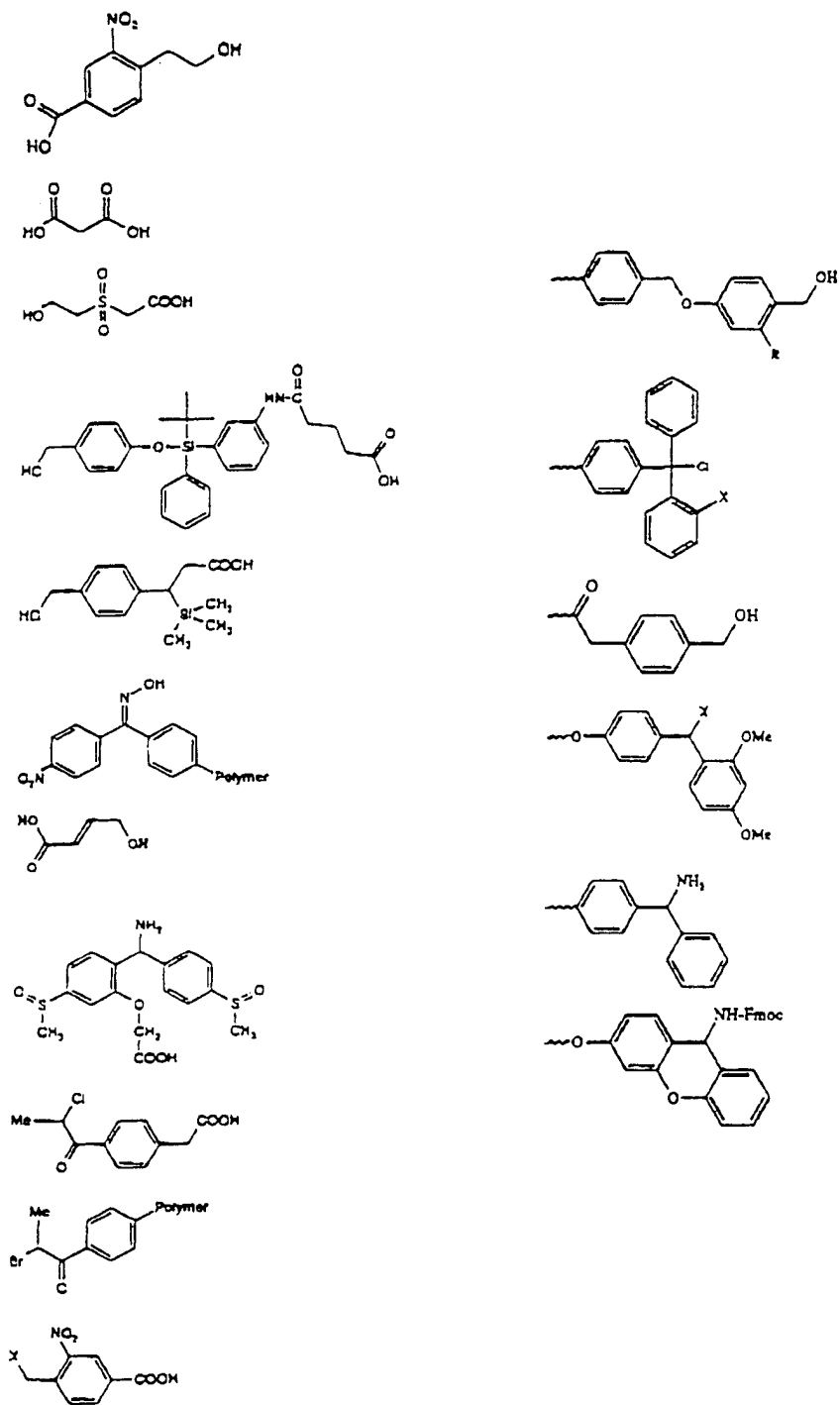

Figure 3

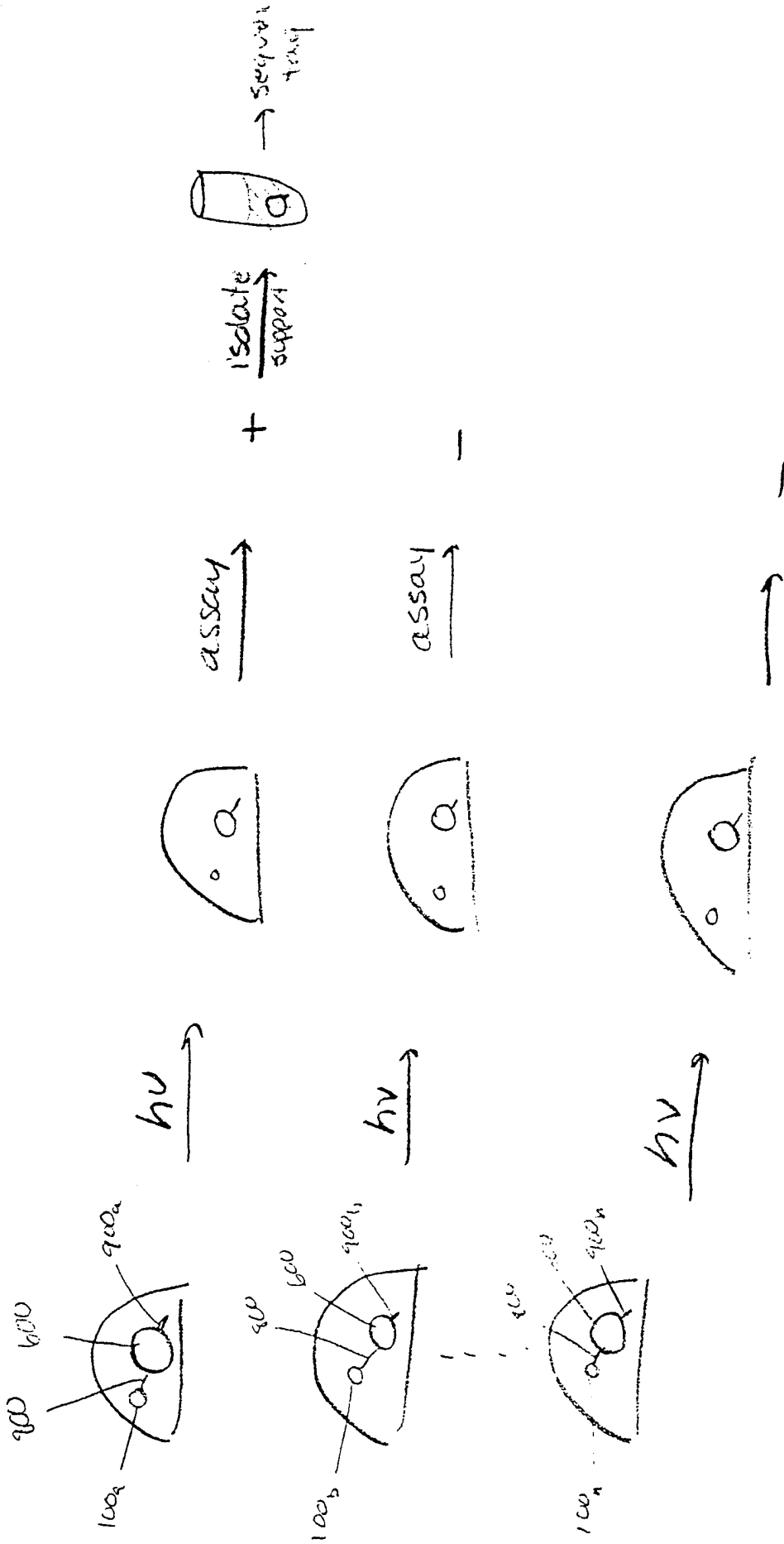

FIG. 4

6 / 4 5

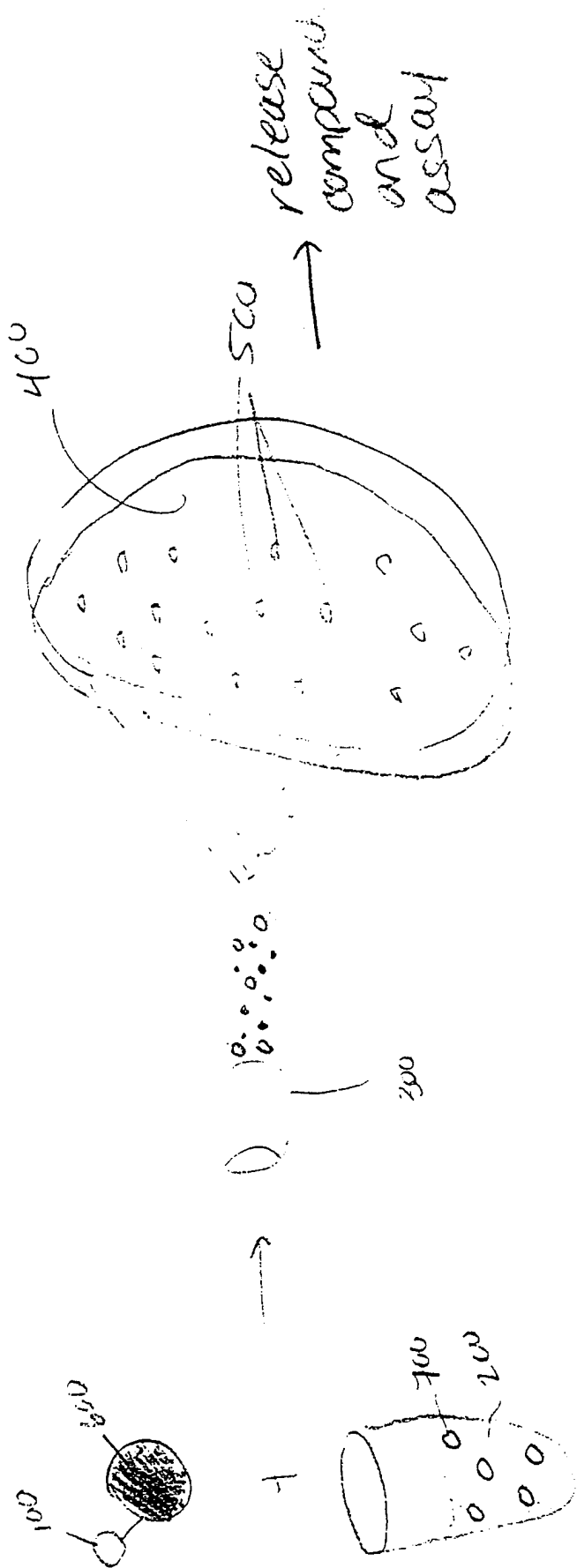

FIG. 5

7 / 4 5

Preparation of the Photocleavable Linker

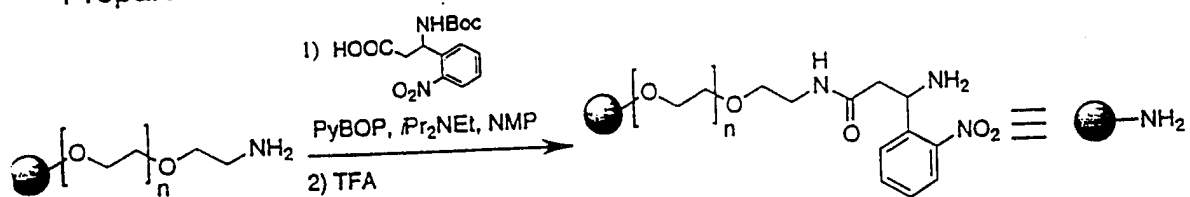

Figure 6

8 / 4 5

Shikimic Acid-Derived Tetracyclic Templates via Tandem Reaction

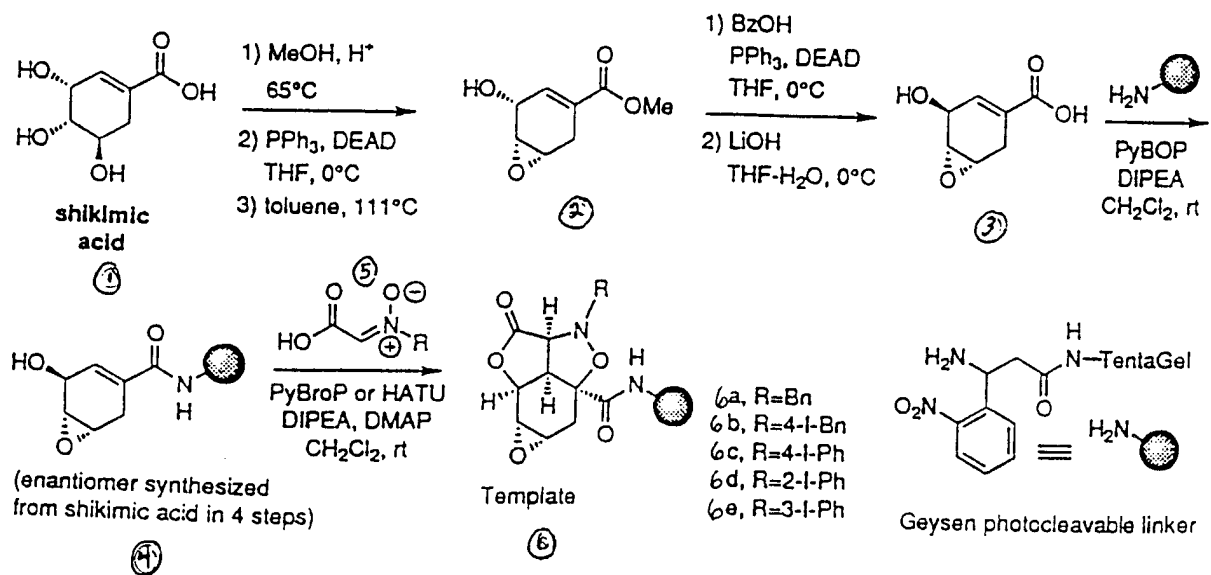

Figure 7

9 / 4 5

Solid Phase Reactions of the Tetracyclic Templates

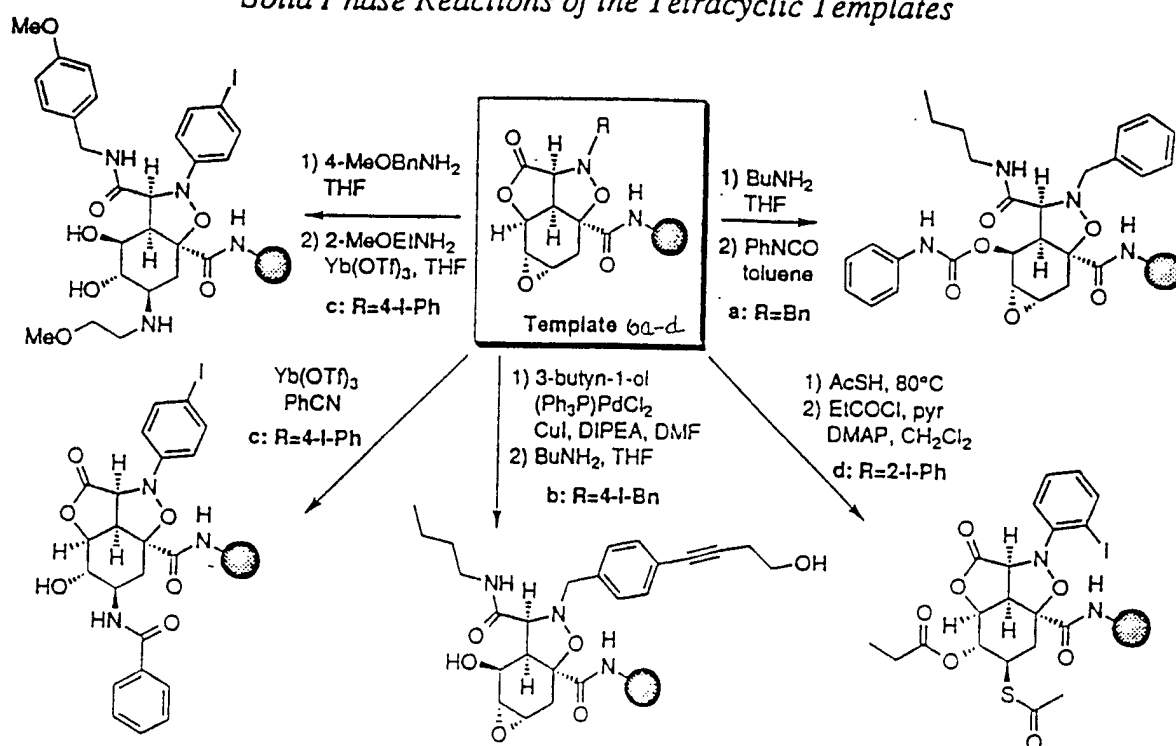
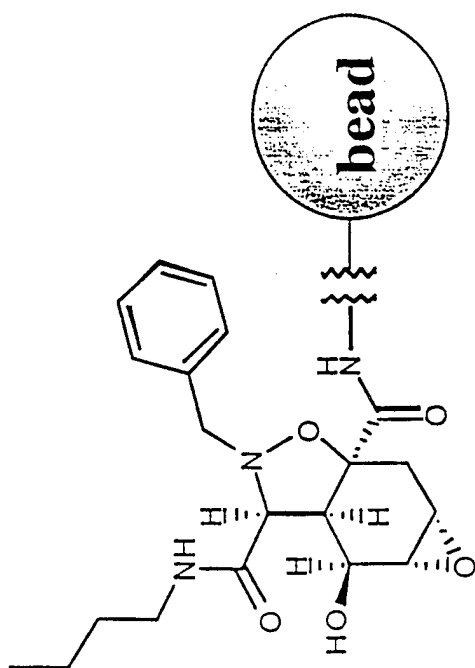
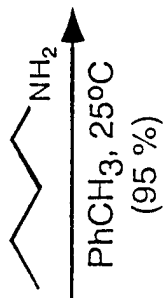
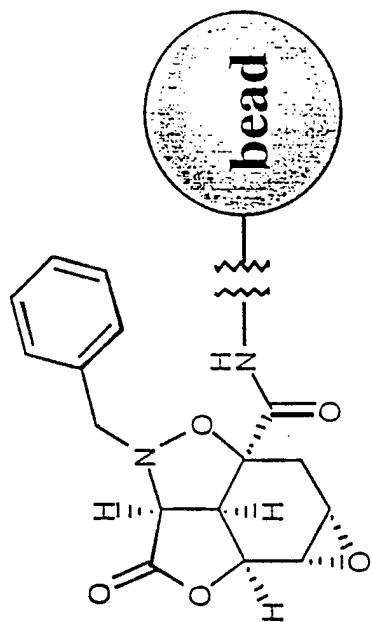

Figure 8

Diversity Expansion: Opening the γ -Lactone

Primary Amines



Secondary Amines

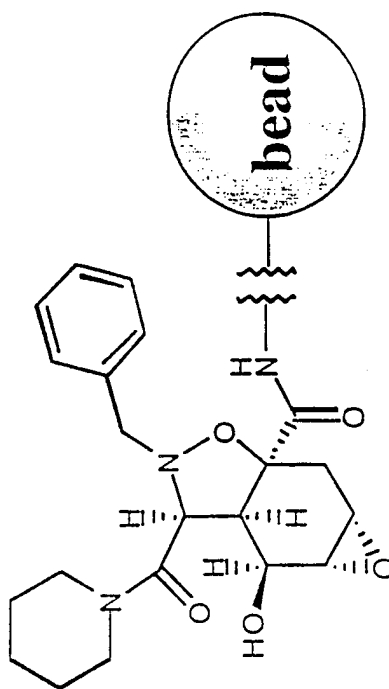
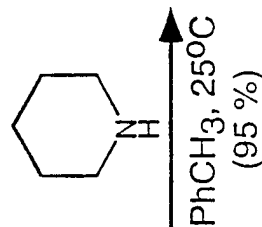
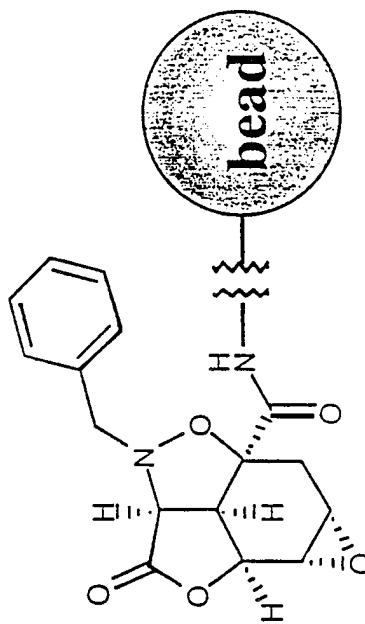

Figure 9

Diversity Expansion: Acylation with an Isocyanate

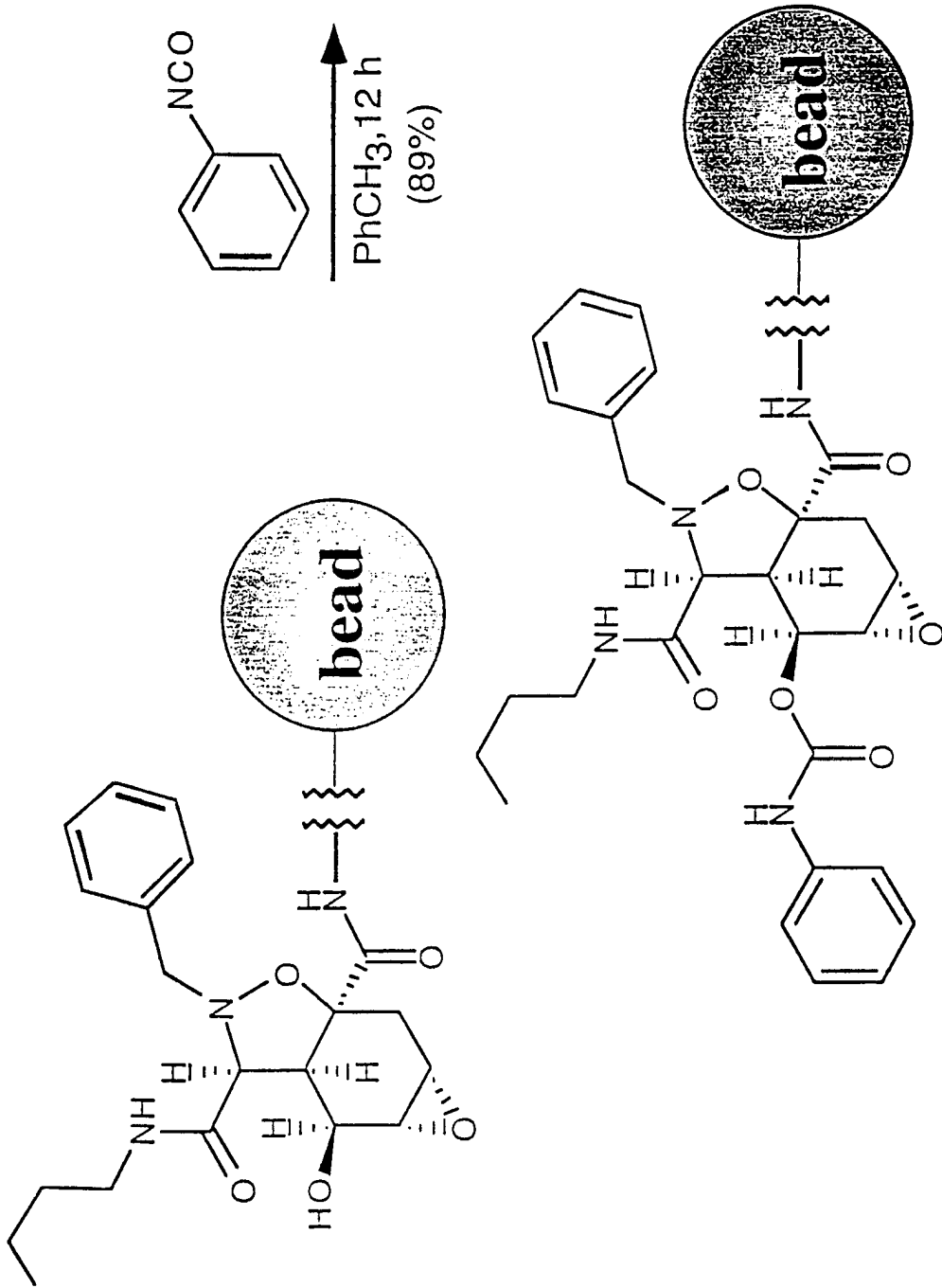

Figure 10

Diversity Expansion: Ytterbium-Catalyzed Epoxide Aminolysis

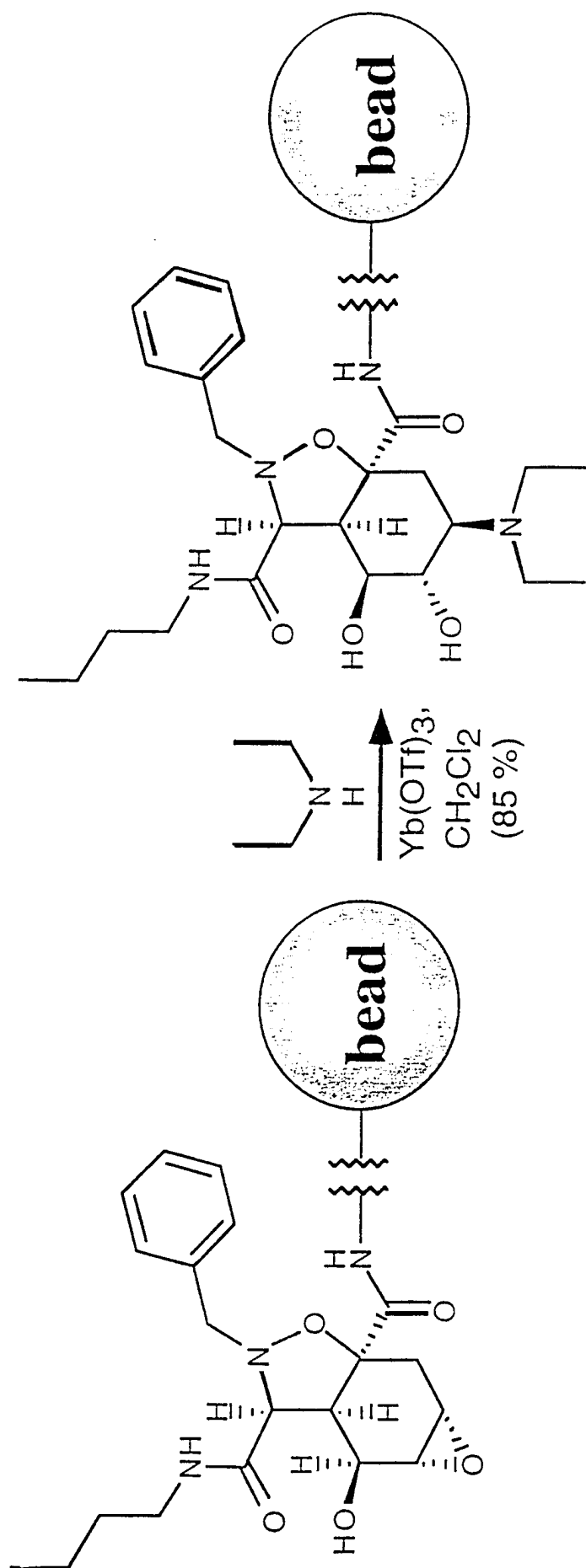

Figure 11

Diversity Expansion: Reaction Based Diversity

R = Amines, Amides,
Olefins, Heterocycles

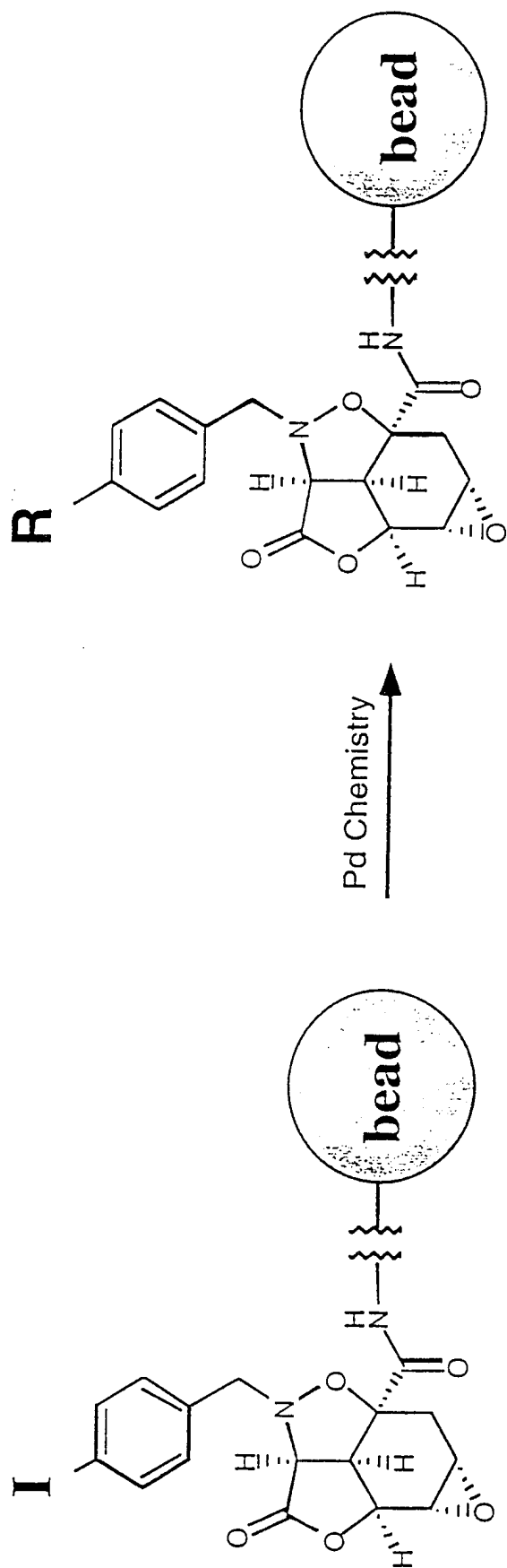

Figure 12

Libraries Based upon the Shikimate-Derived Epoxyhydroxycyclohexene

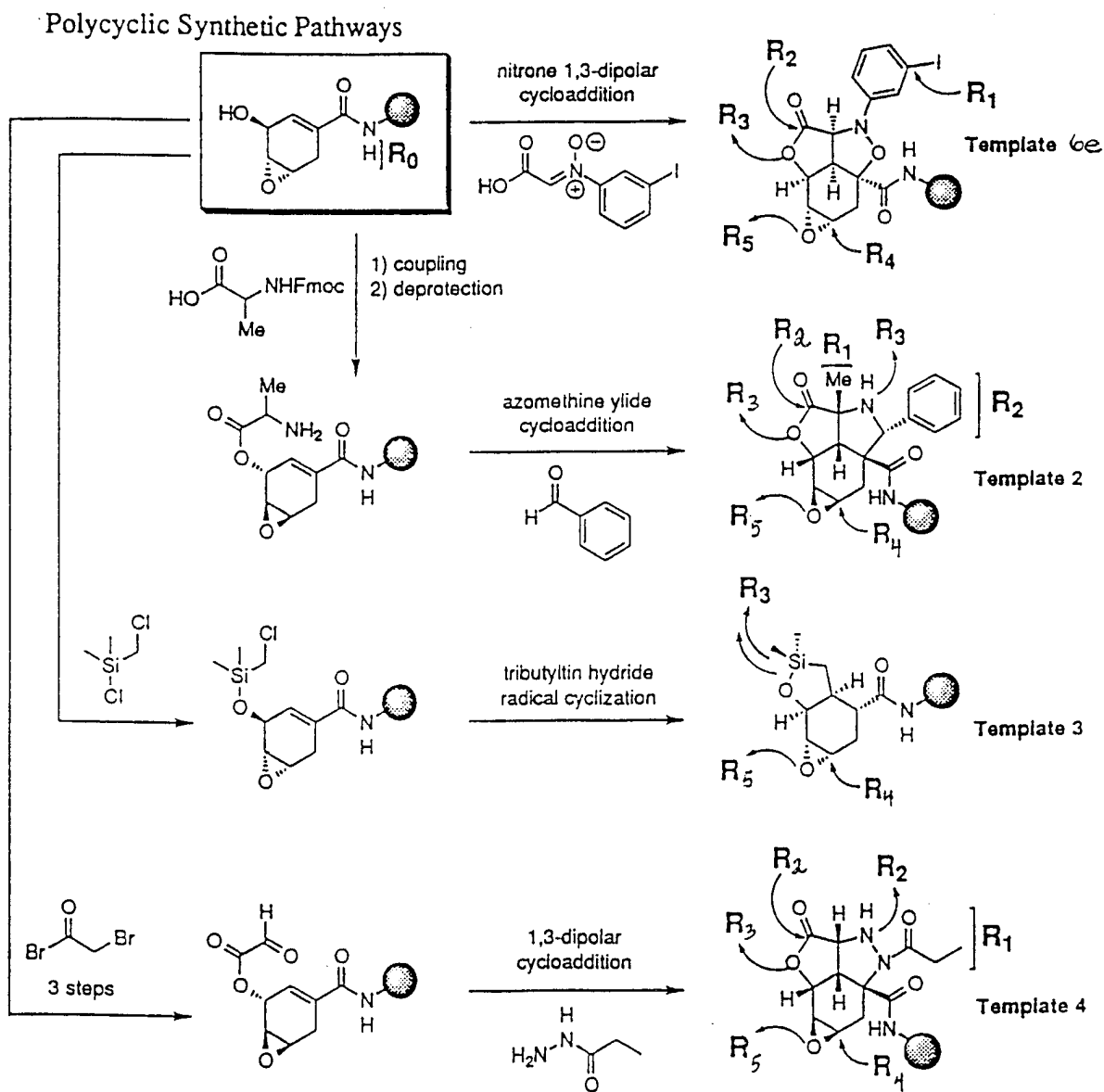
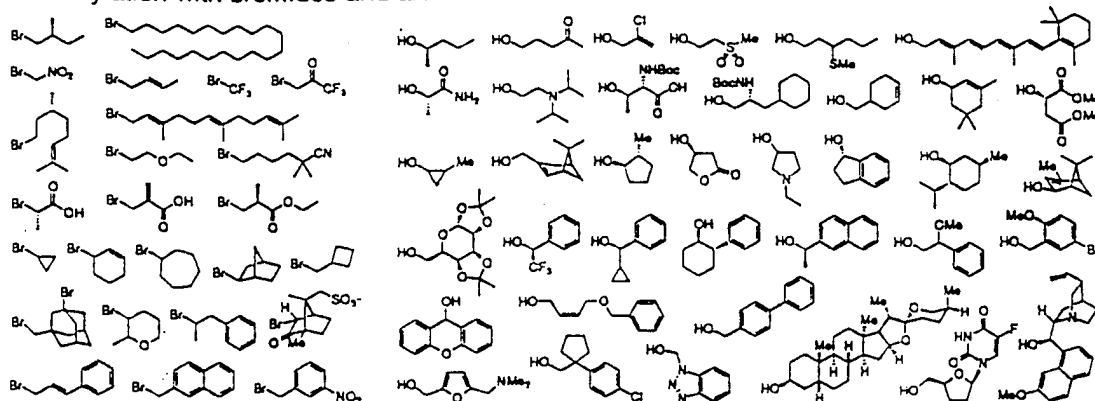

Figure 13

Libraries Based upon the Shikimate-Derived Epoxyhydroxycyclohexene

Representative Monomers for Template 1b-e

R₀: N-alkylation with bromides and alcohols



R₁: Palladium cross-couplings with aryl boronates, stannanes, and terminal alkynes

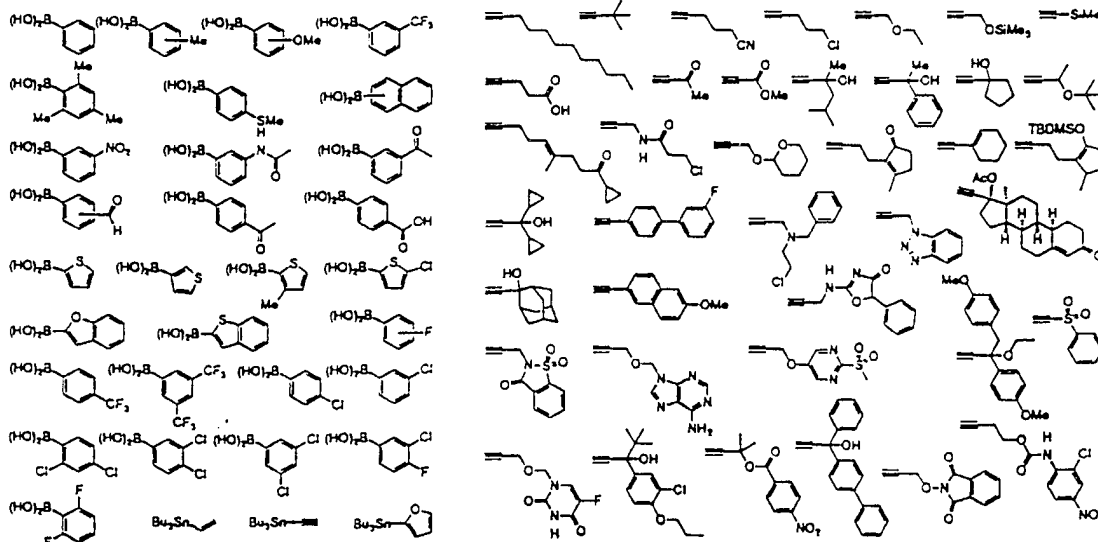

R₂: Lactone opening with amines, hydroxylamines, hydrazines, and hydrazides

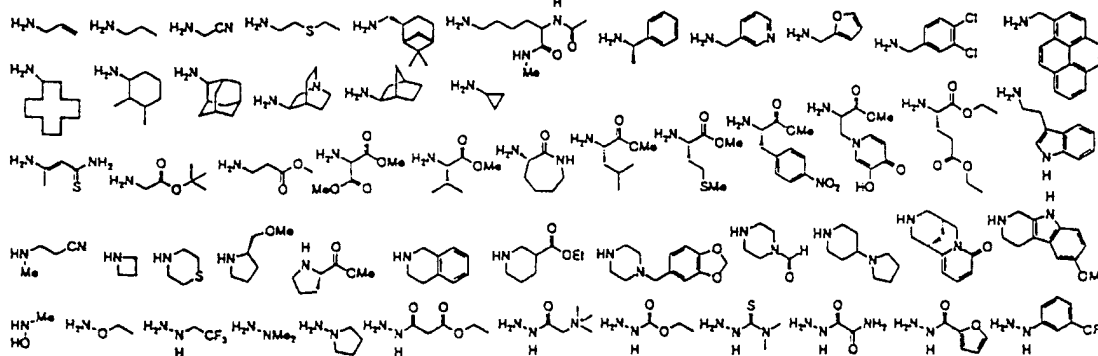
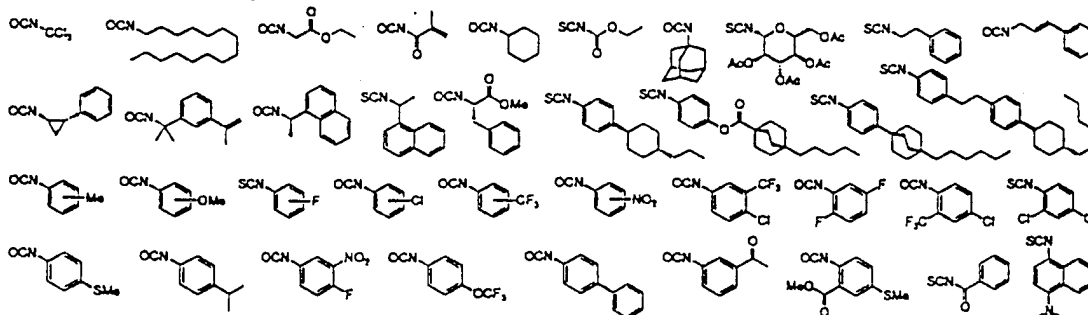

Figure 14

Libraries Based upon the Shikimate-Derived Epoxyhydroxycyclohexene

Representative Monomers for Template 1b-e

R₃: Lactone alcohol acylation with isocyanates and thioisocyanates



R₄: Epoxide opening with nitriles and thiols

(See also R₂ amines)

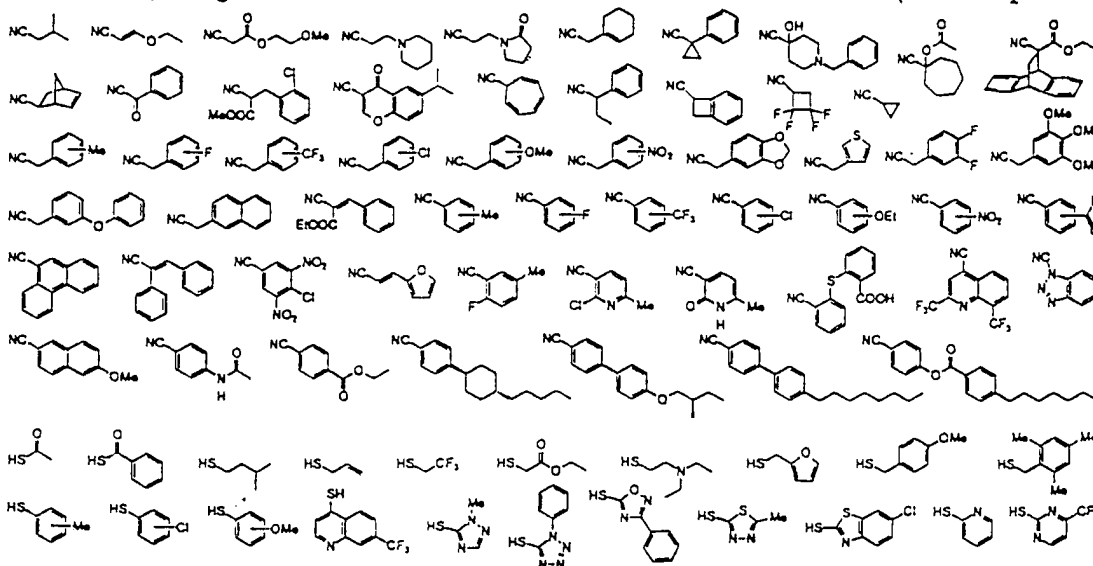

R₅: Epoxide alcohol acylation with acid chlorides and anhydrides

(See also R₃ isocyanates)

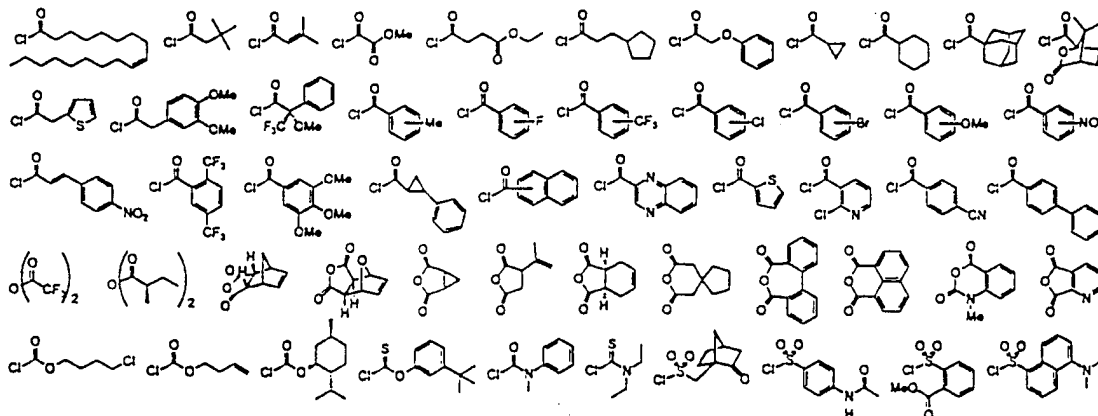
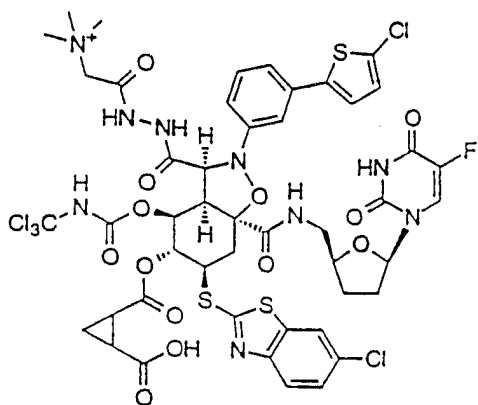

Figure 15

17 / 4 5

Libraries Based upon the Shikimate-Derived Epoxyhydroxycyclohexene

Representative Library Members for Templates 6, b-e, 2, 3, and 4



Library 1 Member

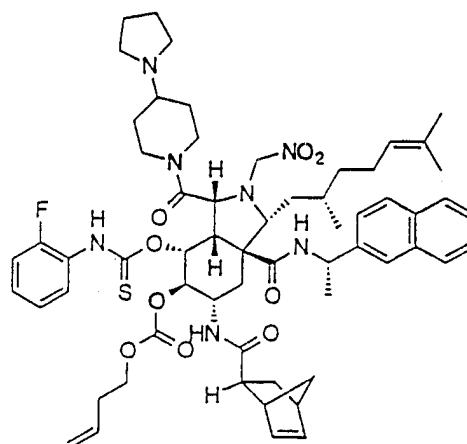

Library 2 Member

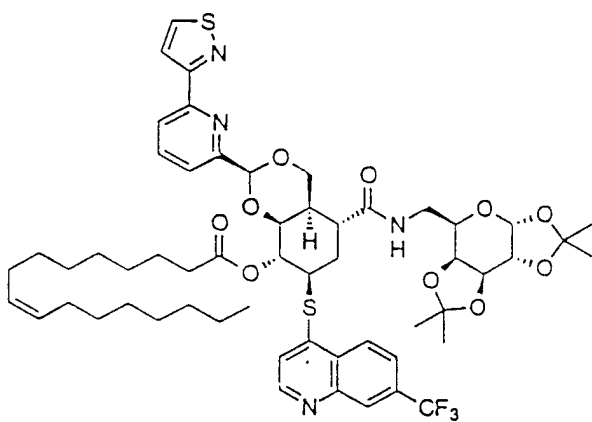

Library 3 Member

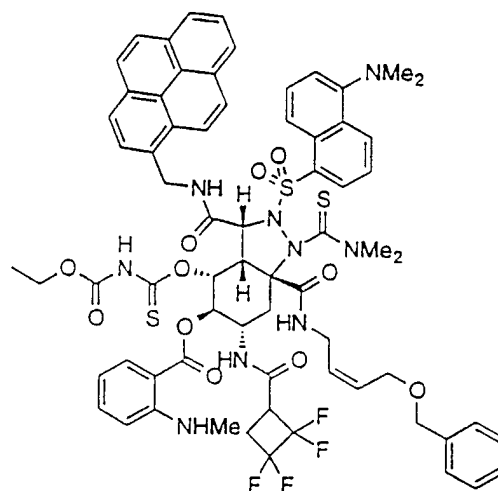

Library 4 Member

Figure 16

Synthesis of Dumbbell Shaped Libraries via Olefin Metathesis

18 / 4 5

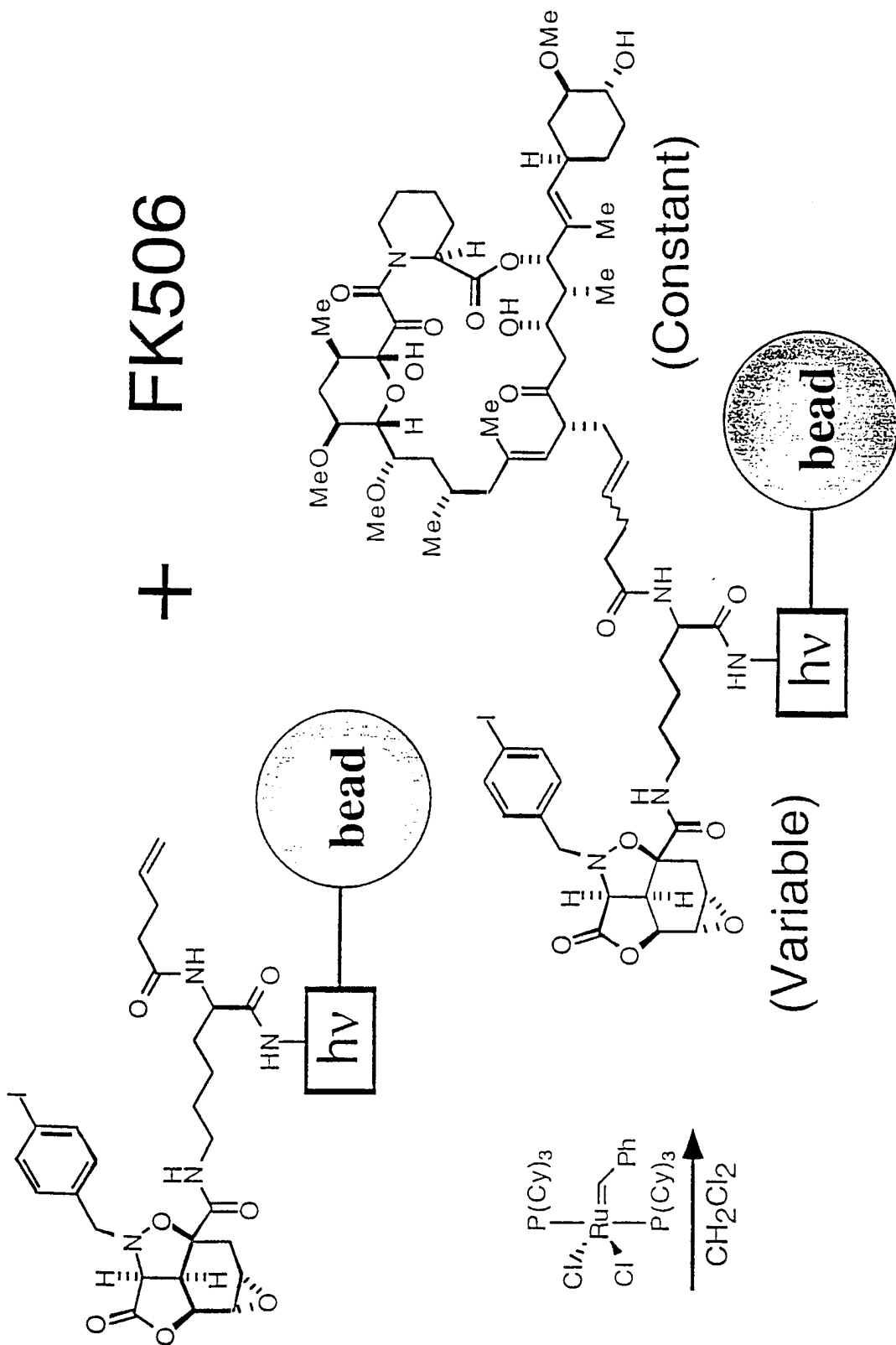
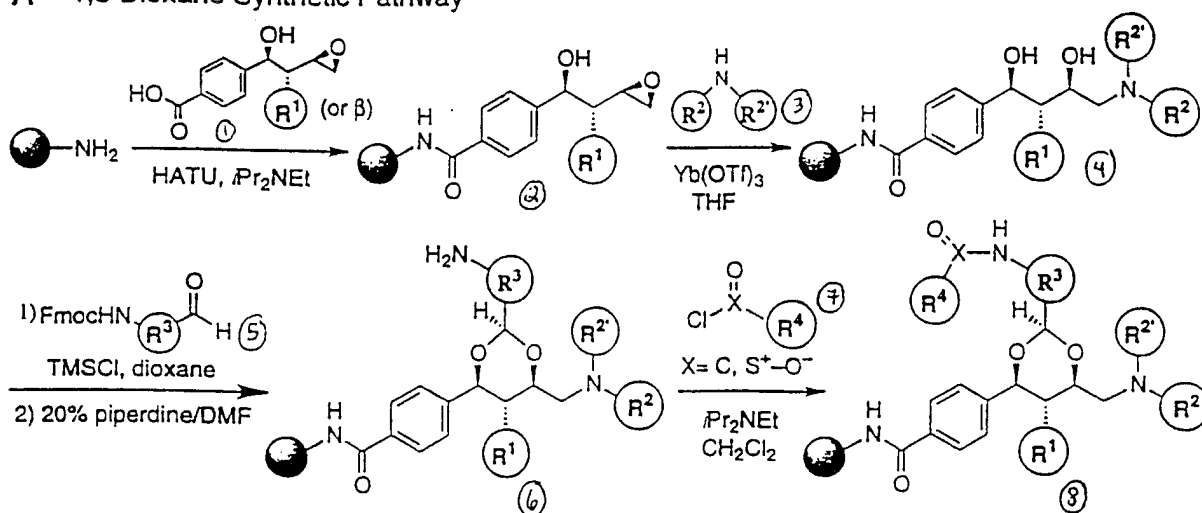
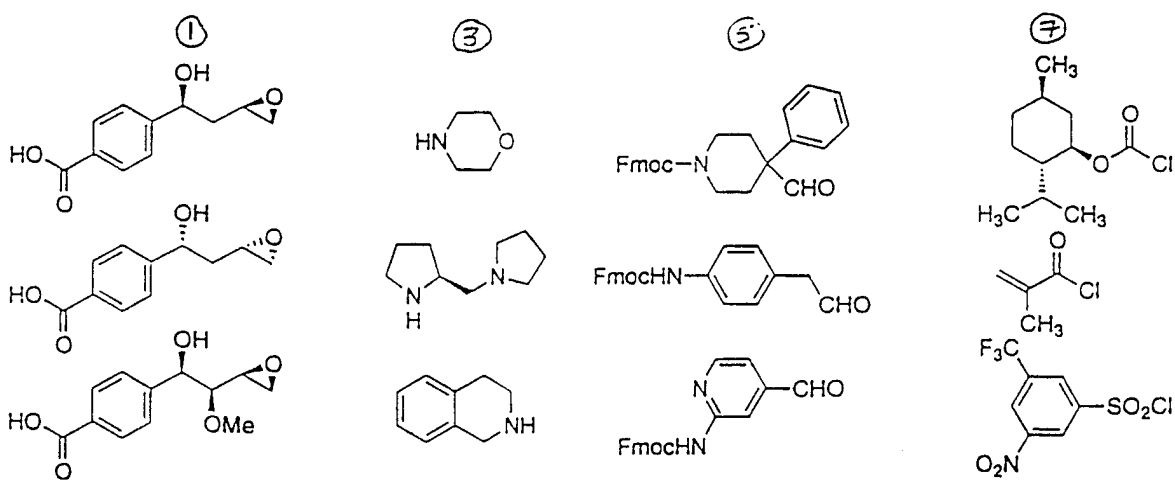

Figure 17

A 1,3-Dioxane Synthetic Pathway



B Representative Monomers



C Representative Synthetic Molecules

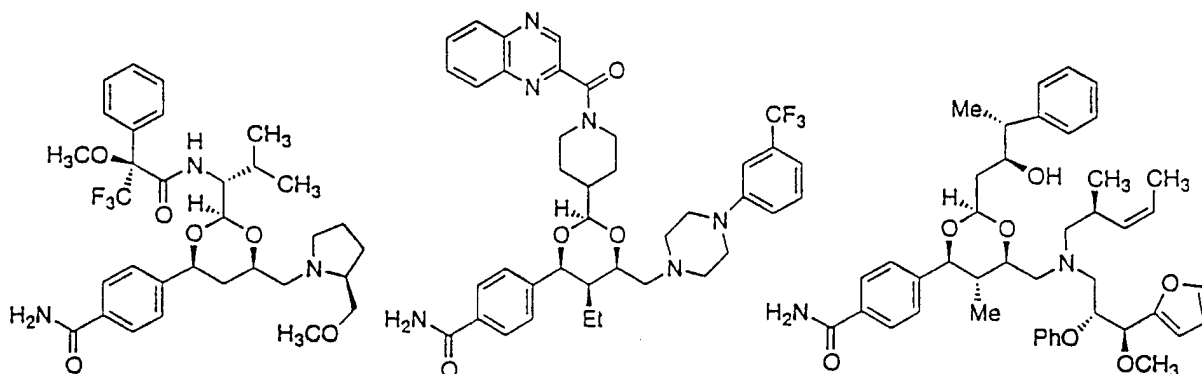

Figure 18

20 / 4 5

Pyridinium Salts as Synthetic Intermediates for Combinatorial Chemistry

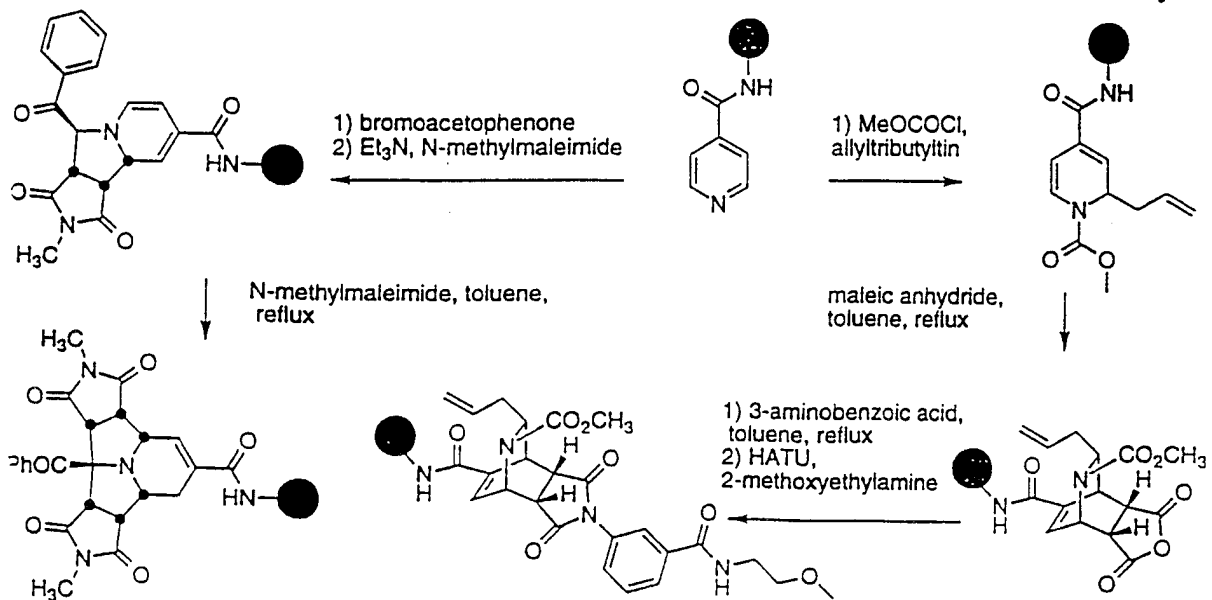
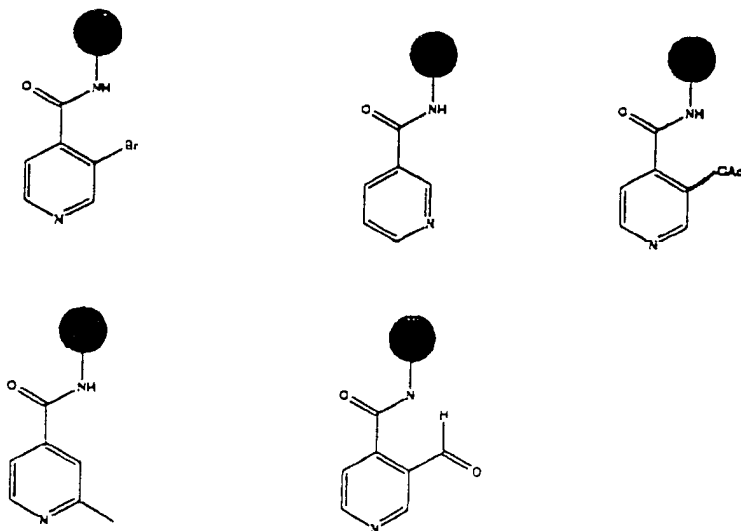

Figure 19

21 / 4 5

Representative Pyridine Nuclei



Bromoketones

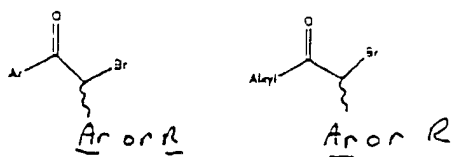

Ar= heterocycles, functionalized phenyl rings, saturated and unsaturated alkyl groups.

maleimide replacements
any dieneophile

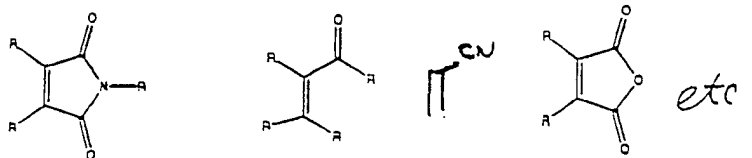

R= alkyl or aryl

Figure 20

22 / 4 5

Diels-Alder Synthetic Pathway

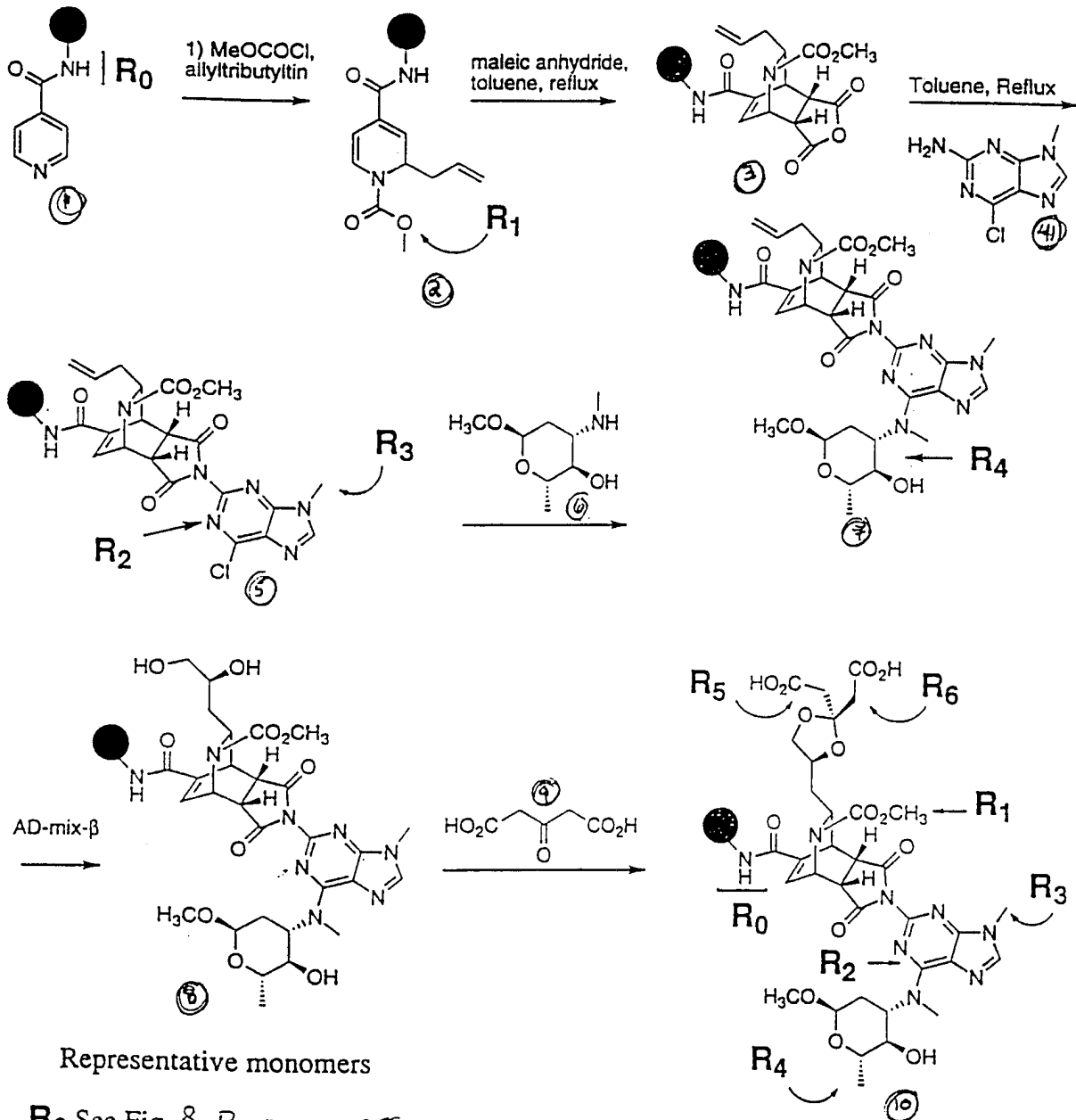

R₀ See Fig. 8, R₀ monomers

R₁ See Fig. 8, R₀ alcohols

R₂ See Fig. 17

R₃ See Fig. 9, R₃ and R₅

R₄ See Fig. 8, R₂

R₅, R₆ See Fig. 12B, R₃

Figure 21

A Representative monomers continued

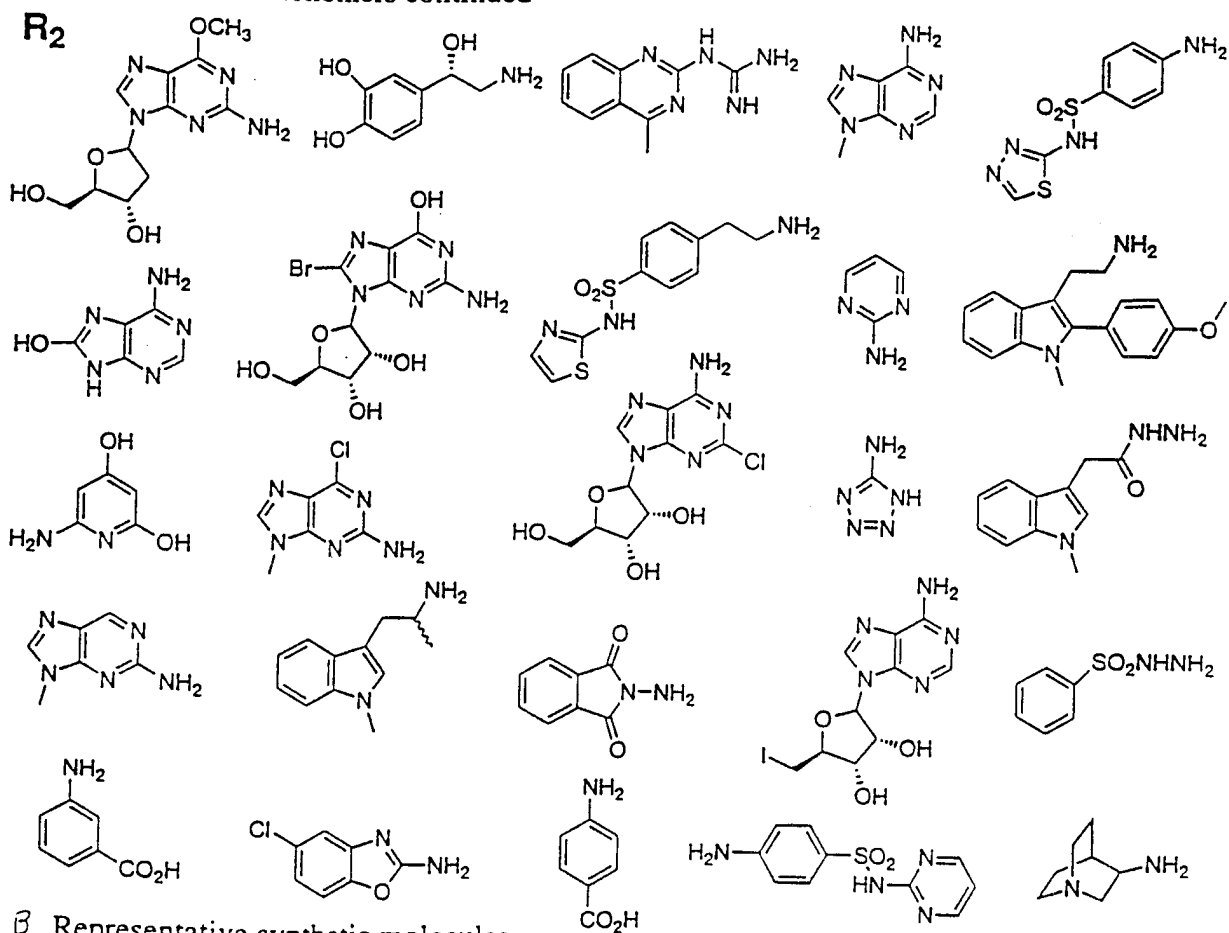

B Representative synthetic molecules

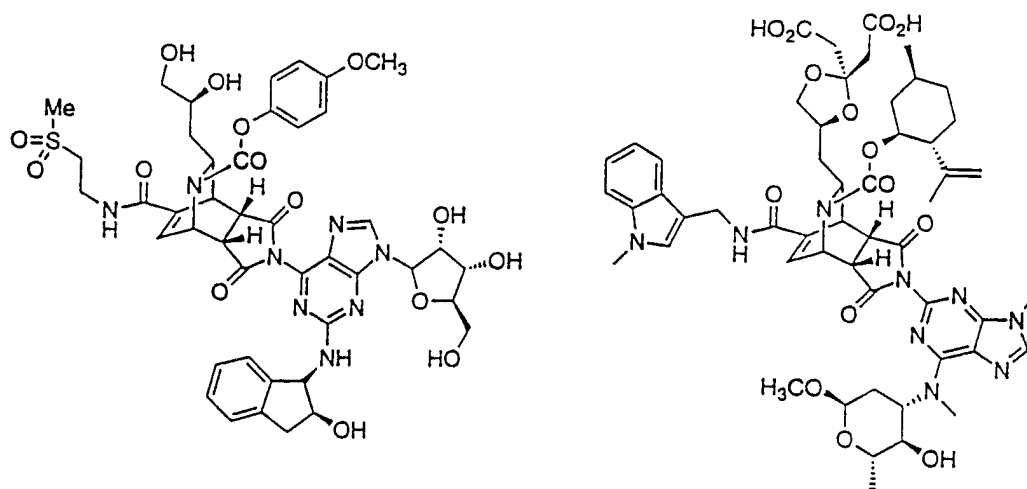

Figure 22

24 / 4 5

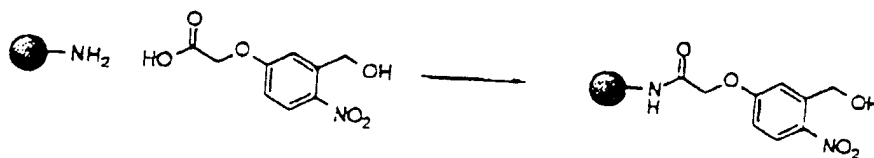

Figure 23A

25 / 4 5



Figure 23B

26 / 4 5

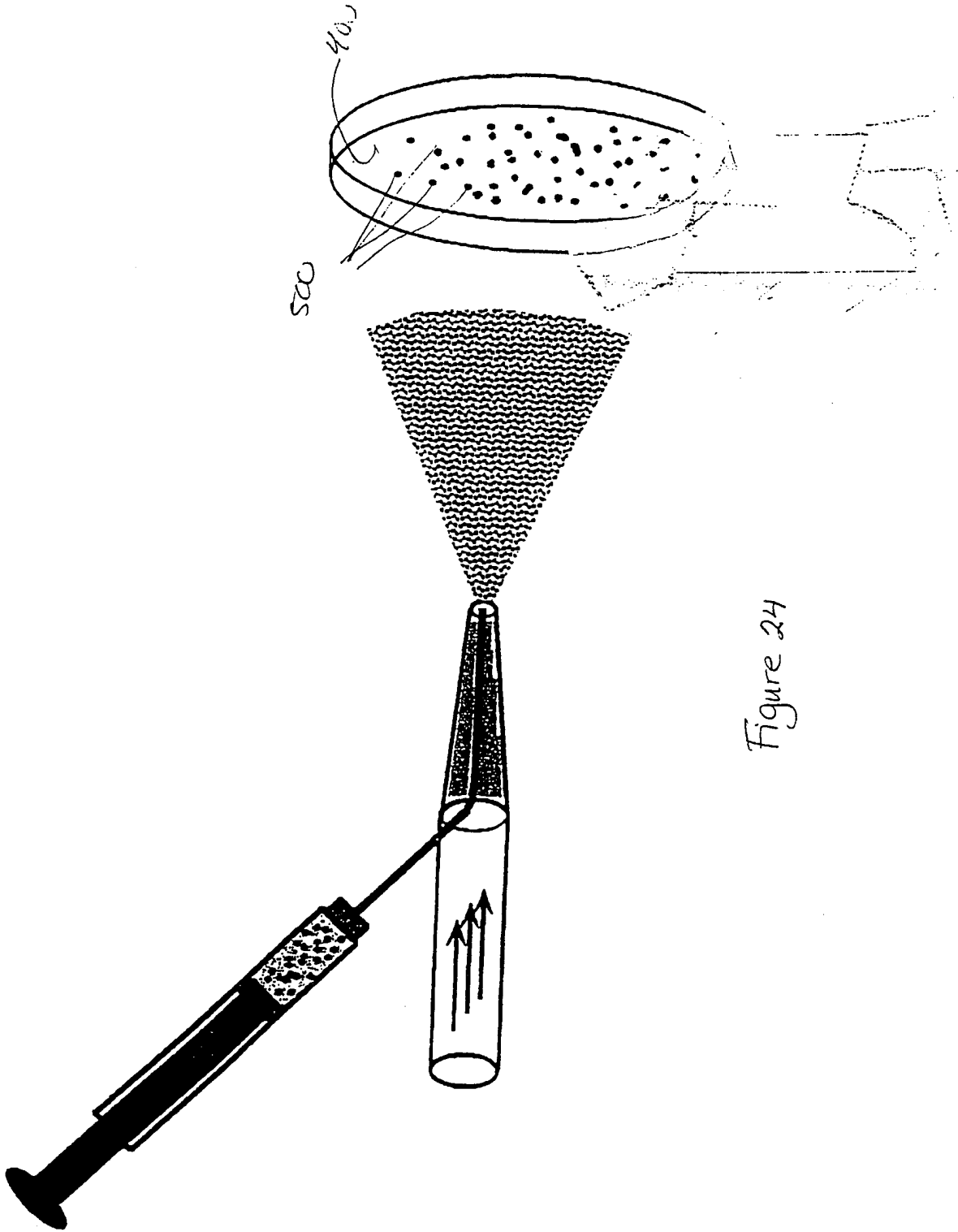

Figure 24

27 / 4 5

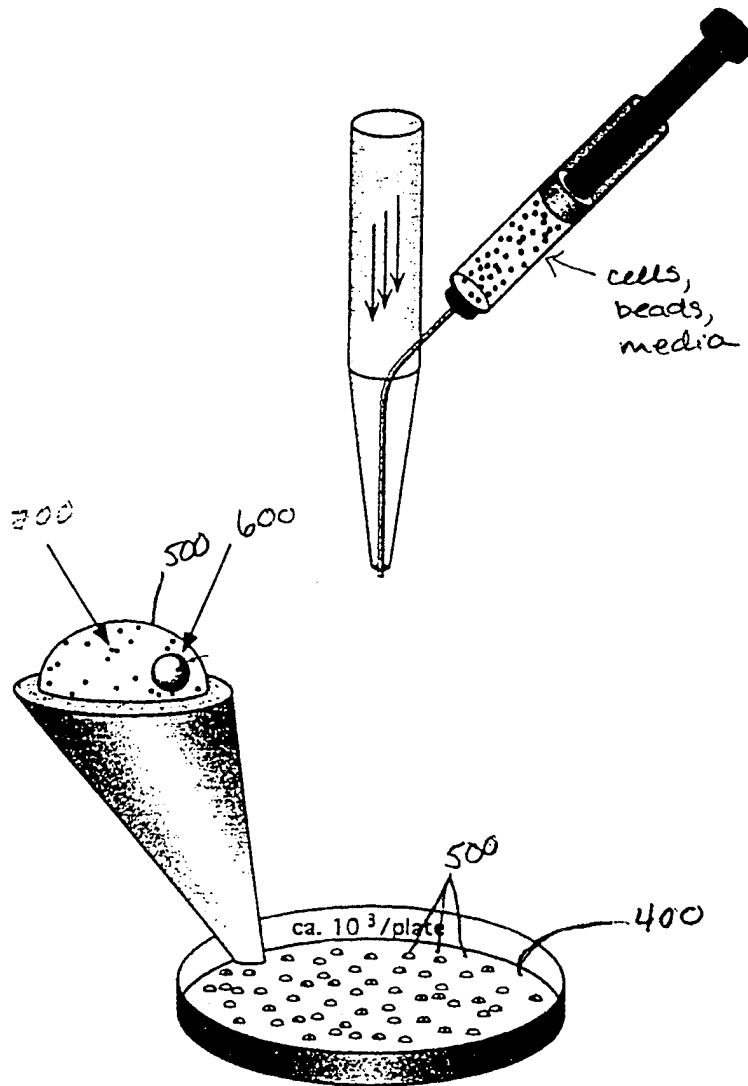

Figure 25

28 / 4 5

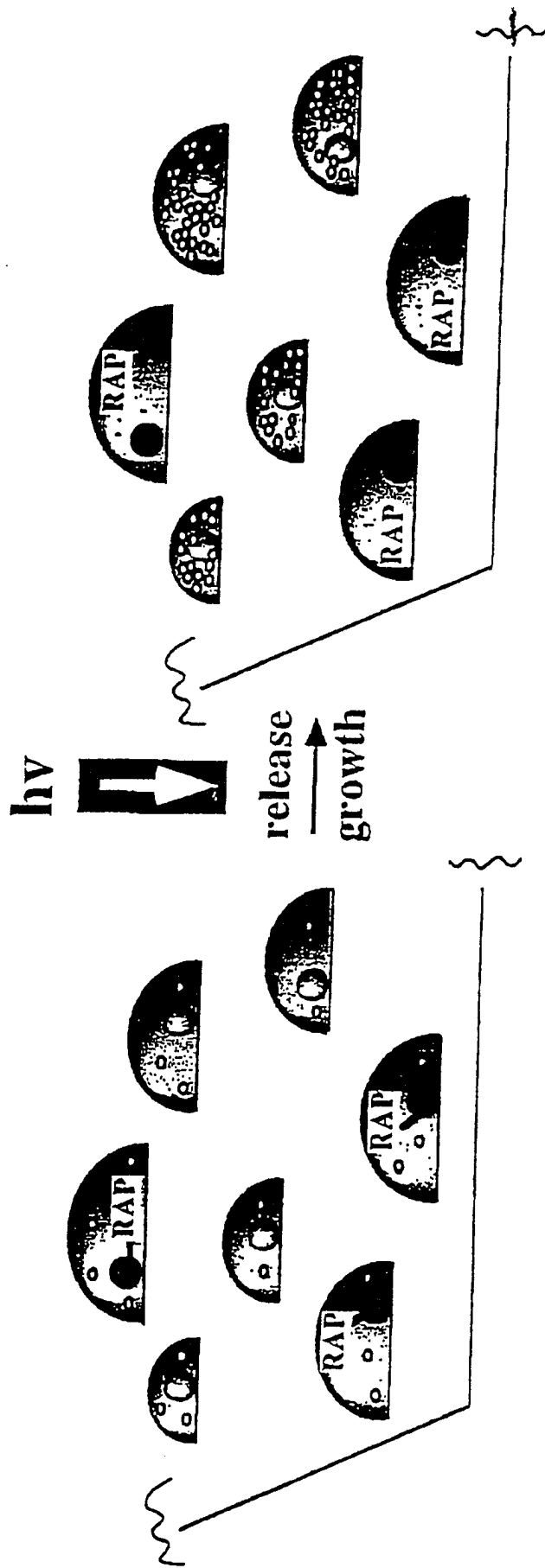

Figure 26

29 / 4 5

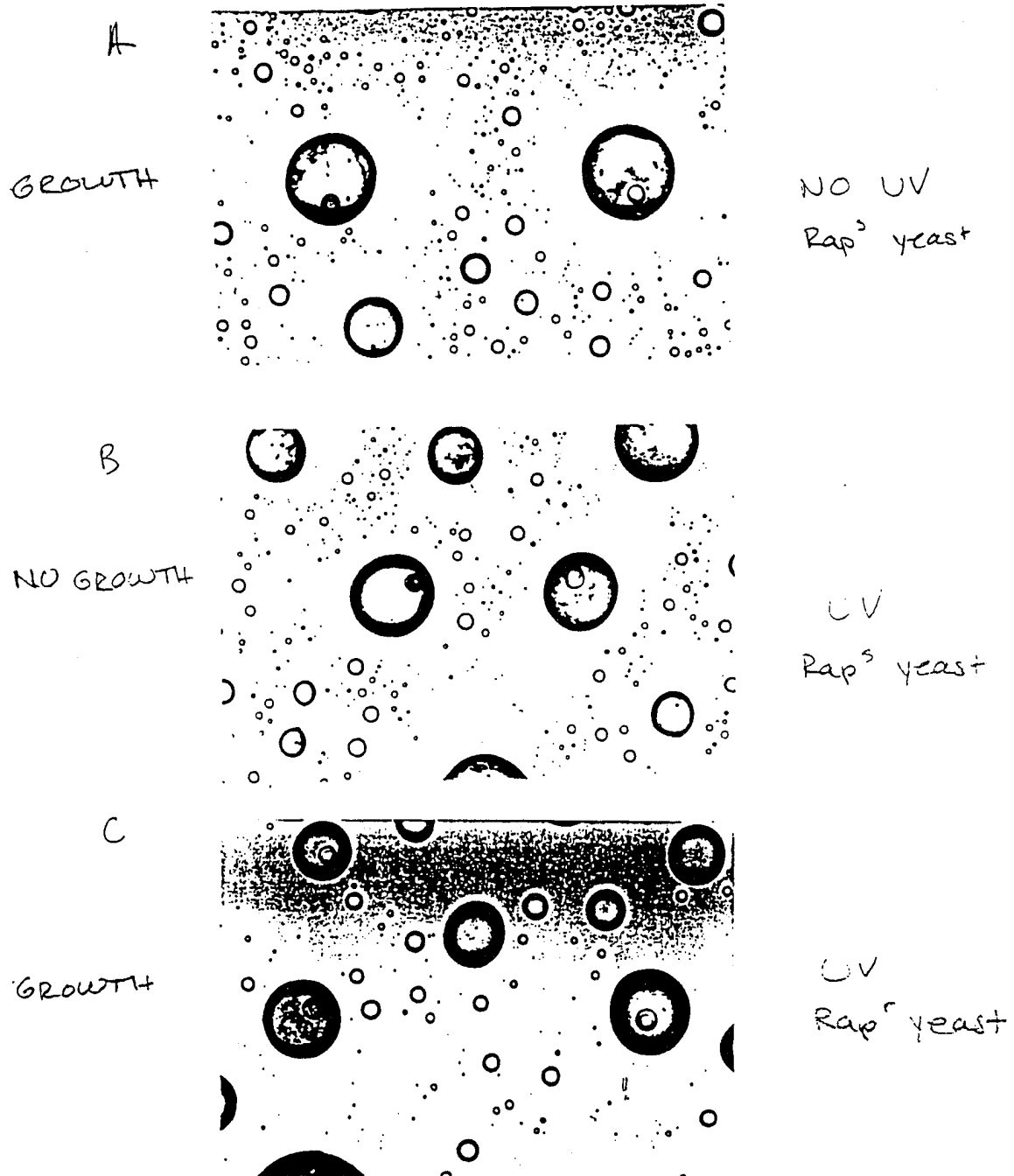

Figure 27

30 / 4 5

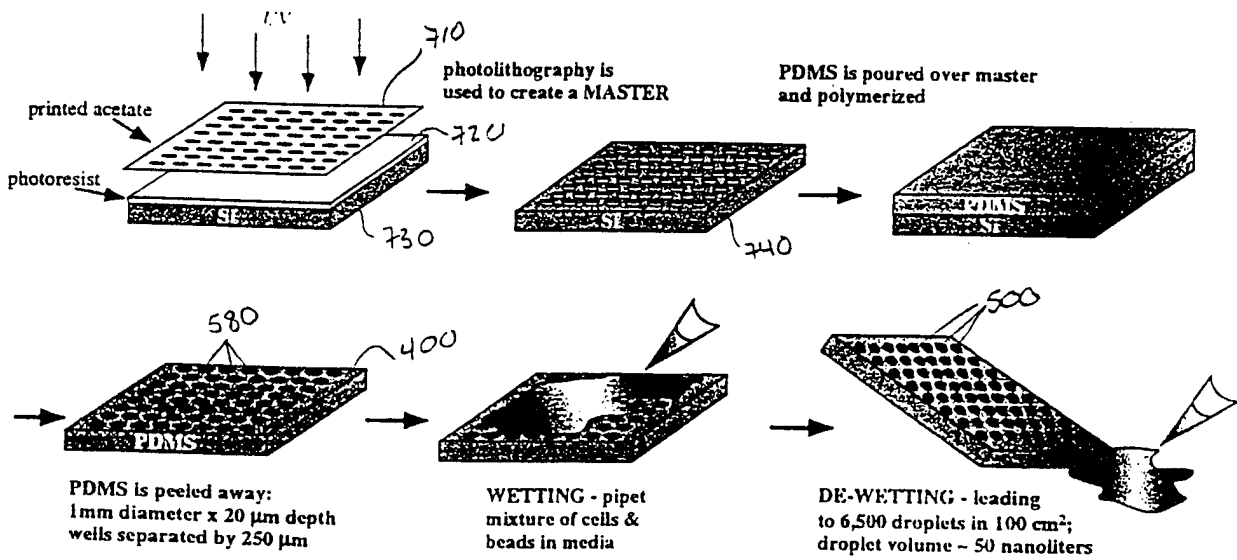
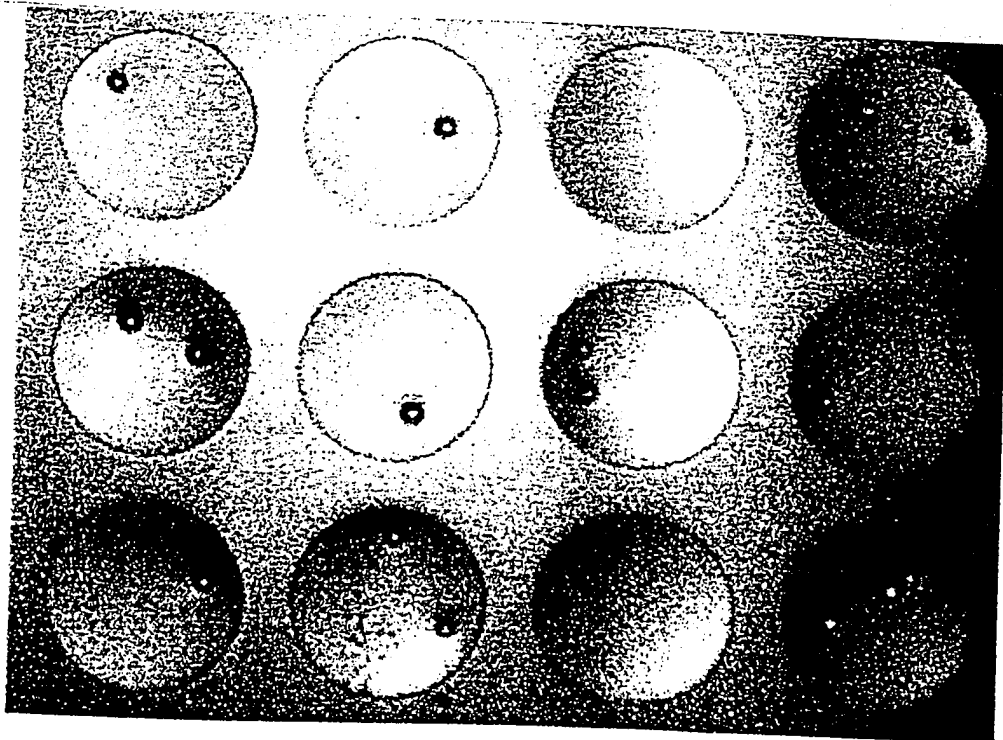

Figure 28

31 / 4 5



droplet volume ~50 nanoliters

Figure 29

32 / 4 5

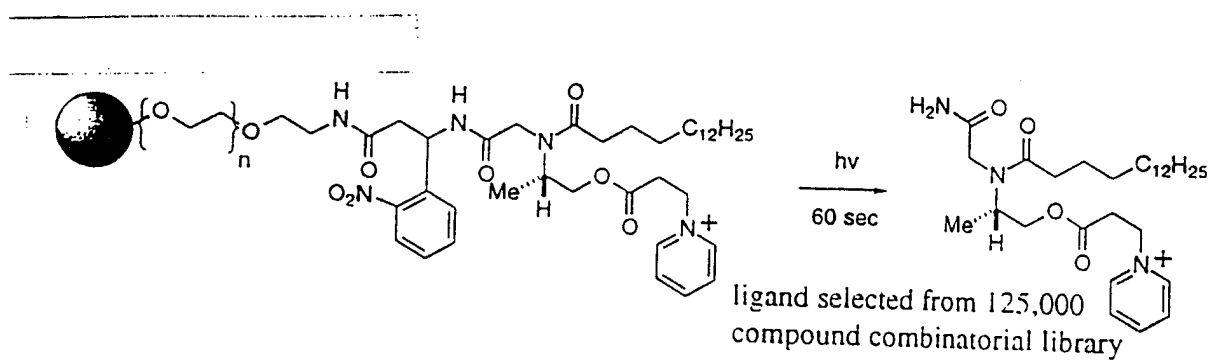
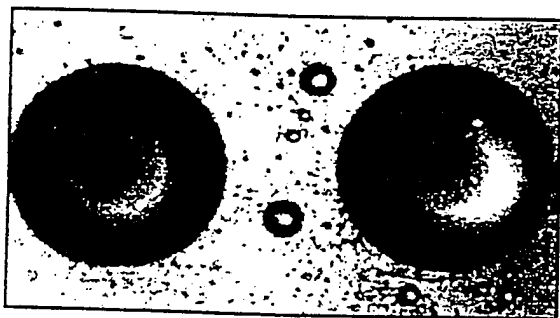

Figure 30

33 / 4 5

No UV, 24 hr. growth



1 min. UV, 24 hr. growth

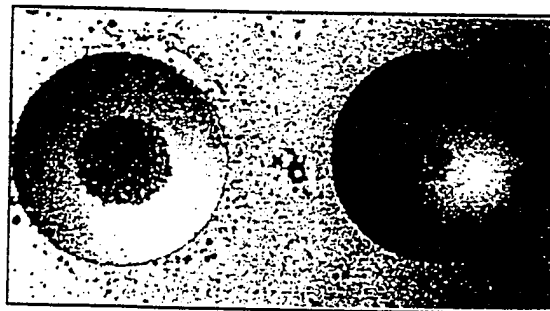

Figure 31

34 / 4 5

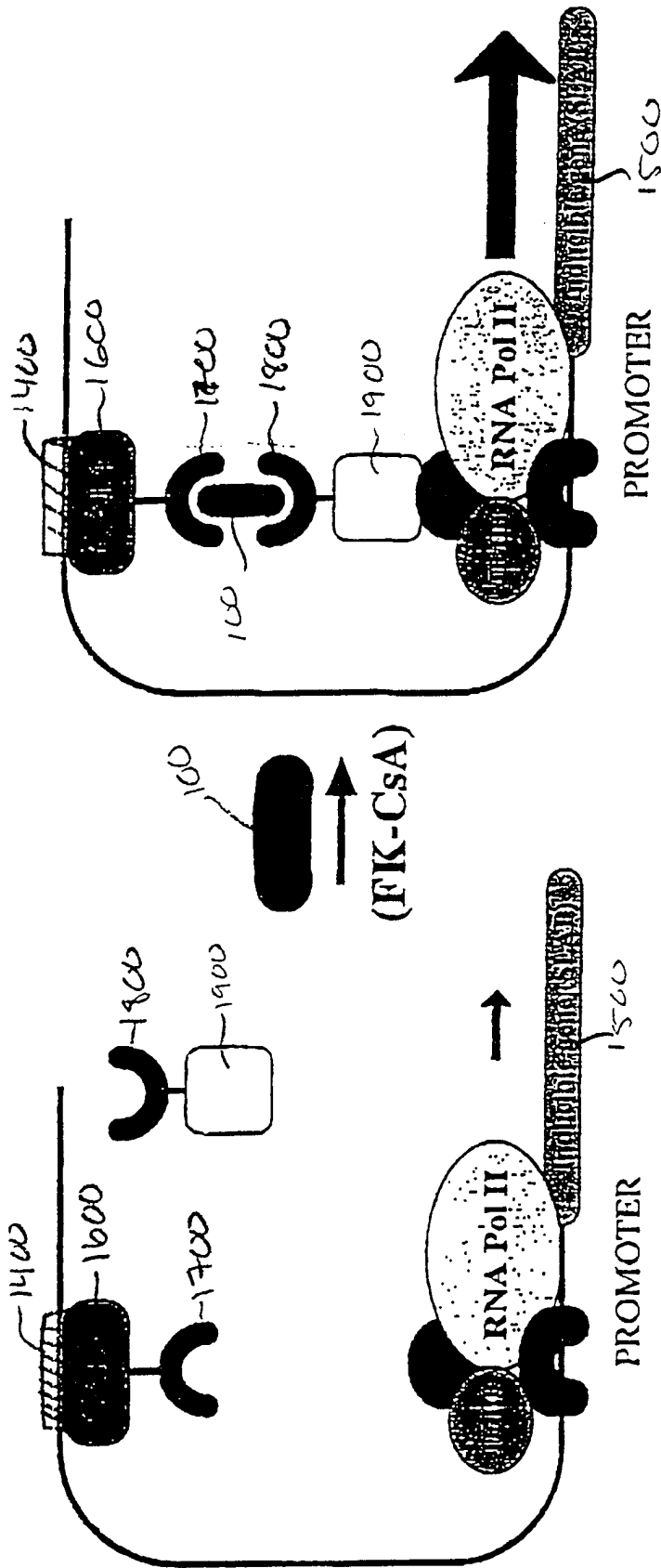

Figure 32

35 / 4 5

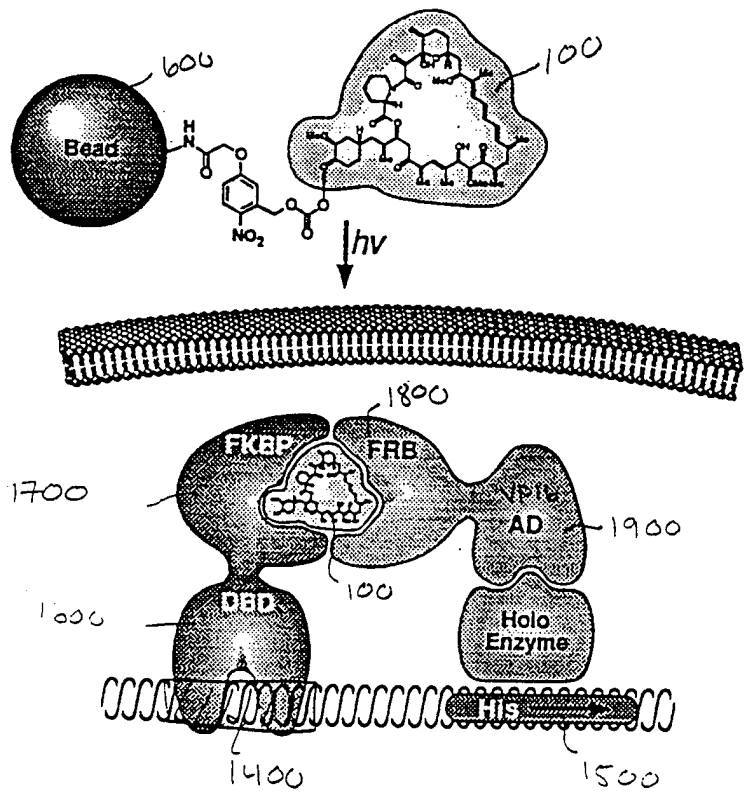

Figure 33

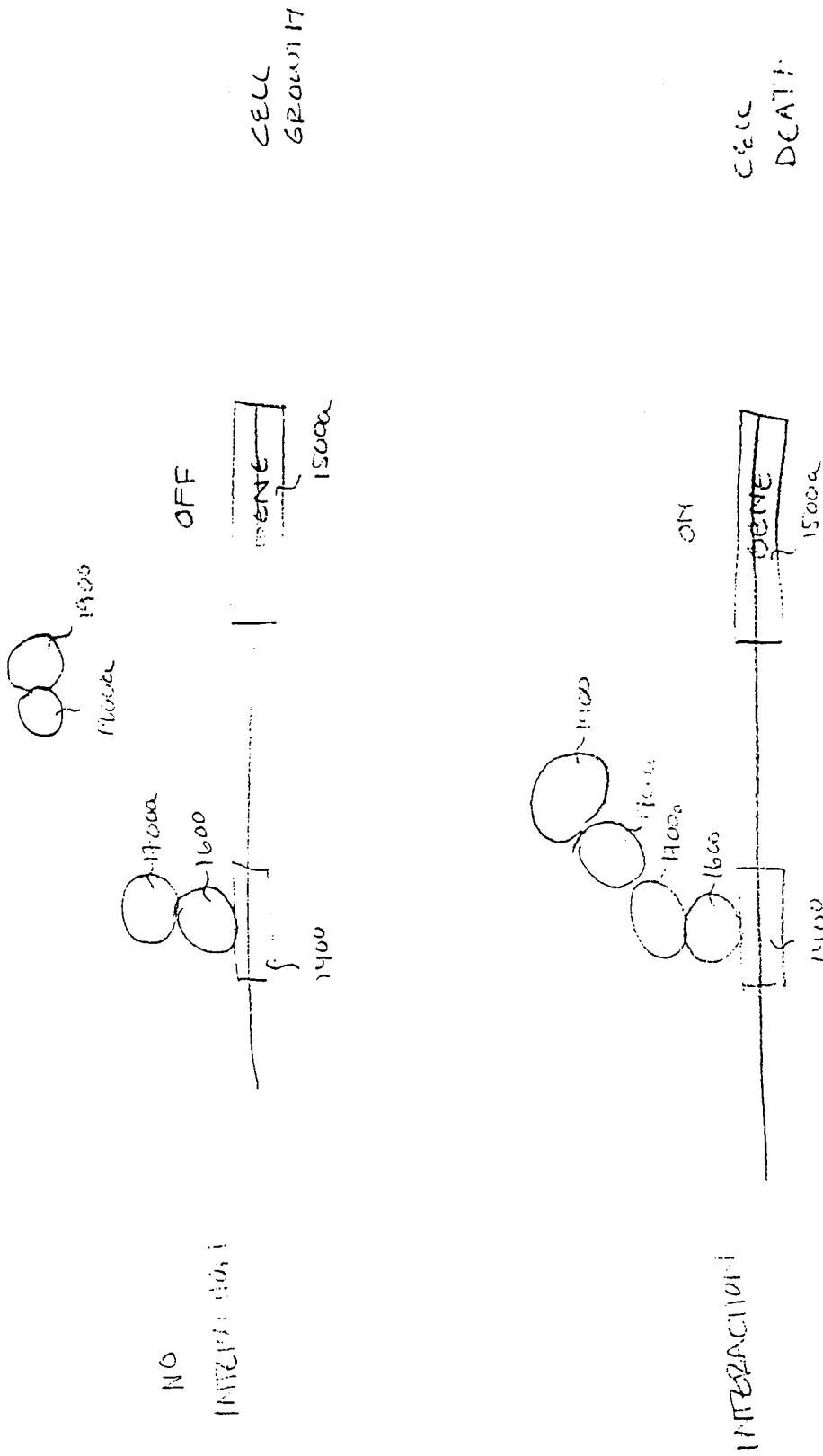

Figure 34

37 / 4 5

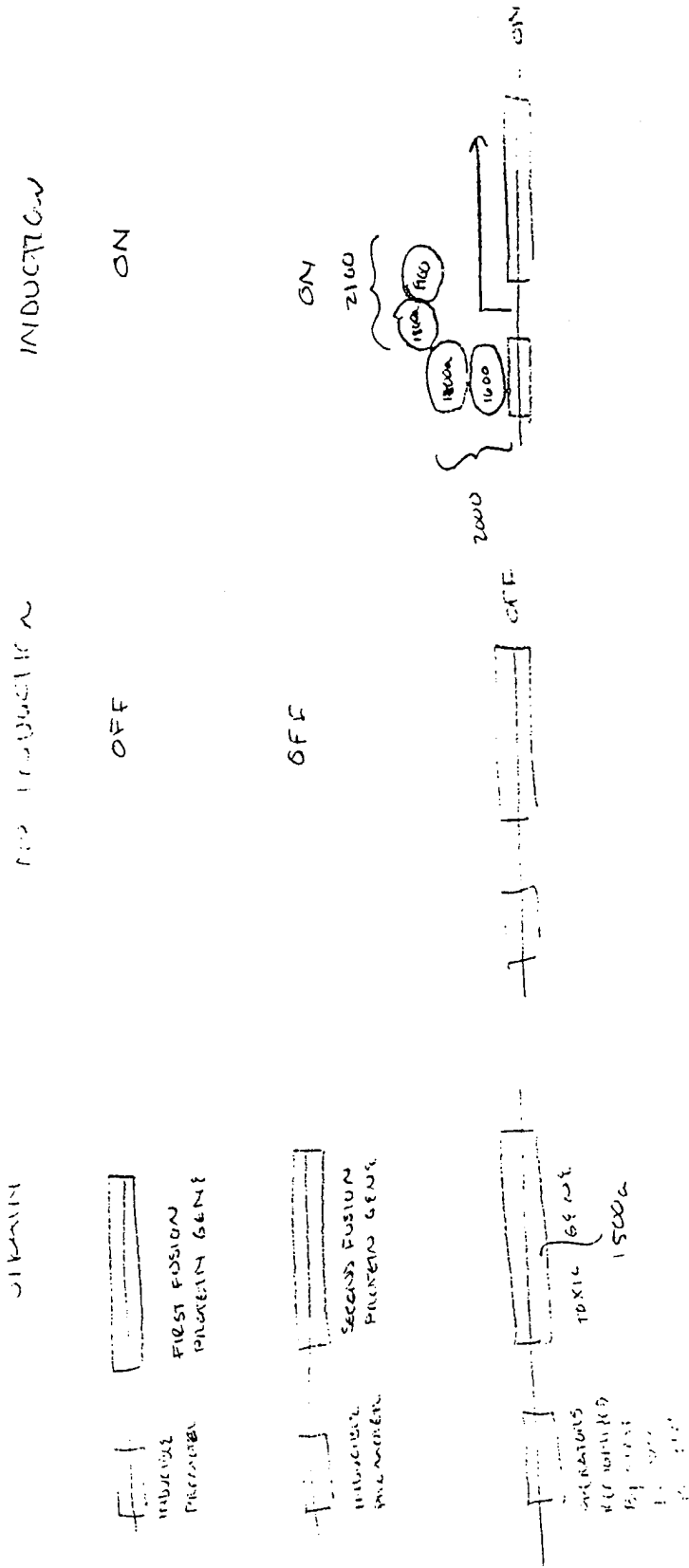
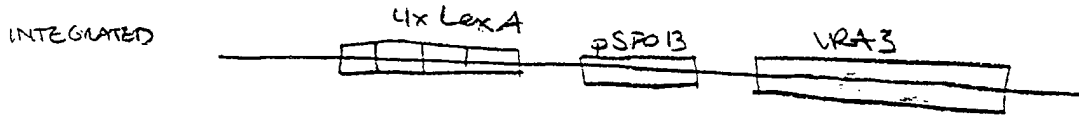
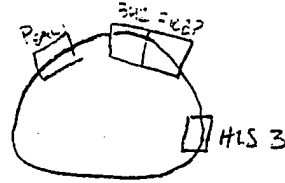
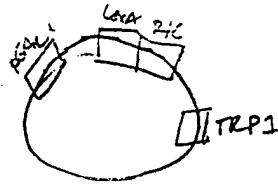

Figure 35

38 / 4 5

A. YEAST STRAIN EGY48

38/45



B

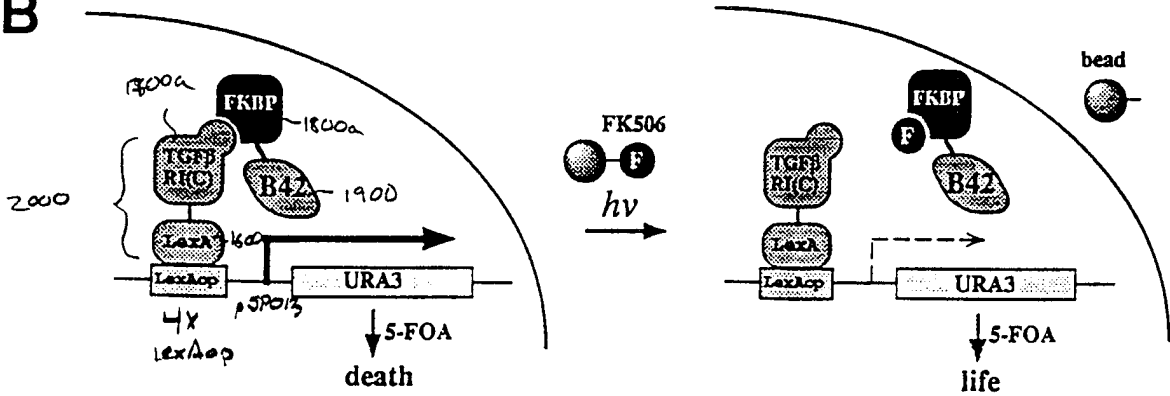

Figure 36

39 / 4 5

Detecting Small Molecule Inhibitors of Protein-Protein Interactions

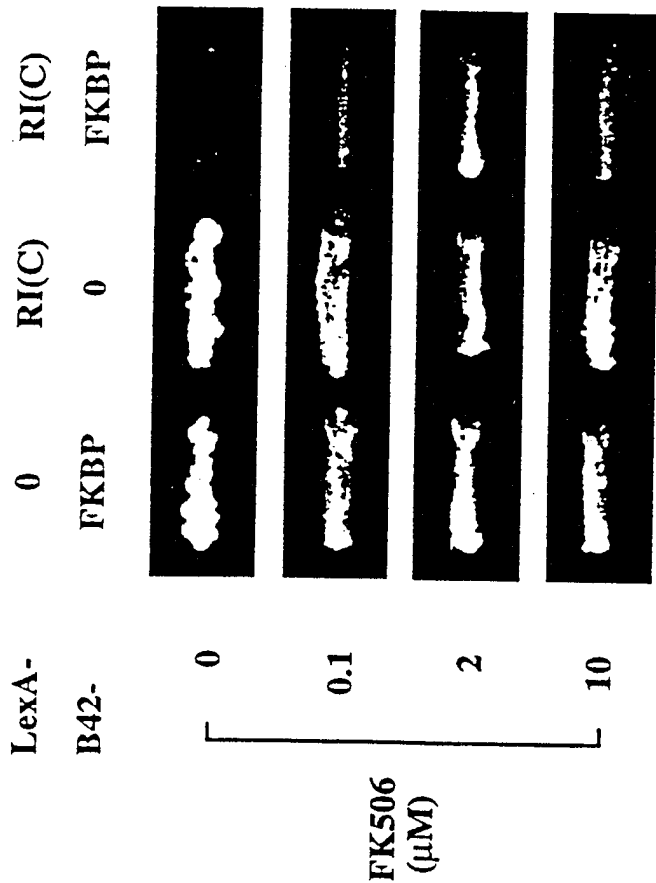
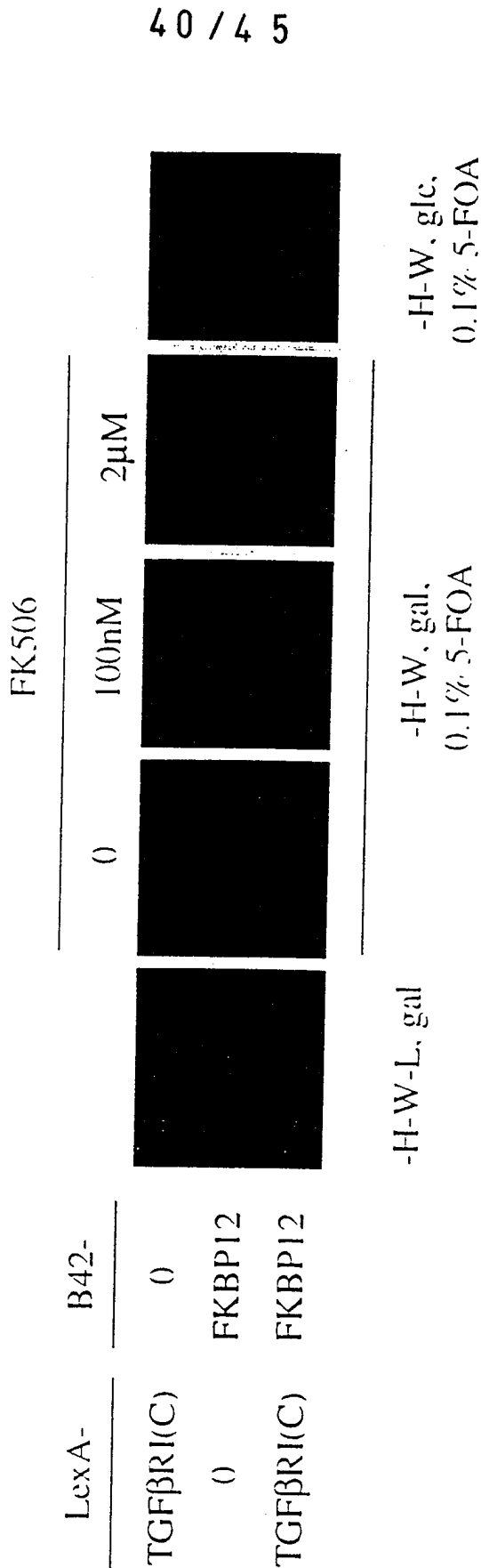

Figure 37-A

Detecting Small Molecule Inhibitors of Protein-Protein Interactions



40 / 4 5

Figure 37B

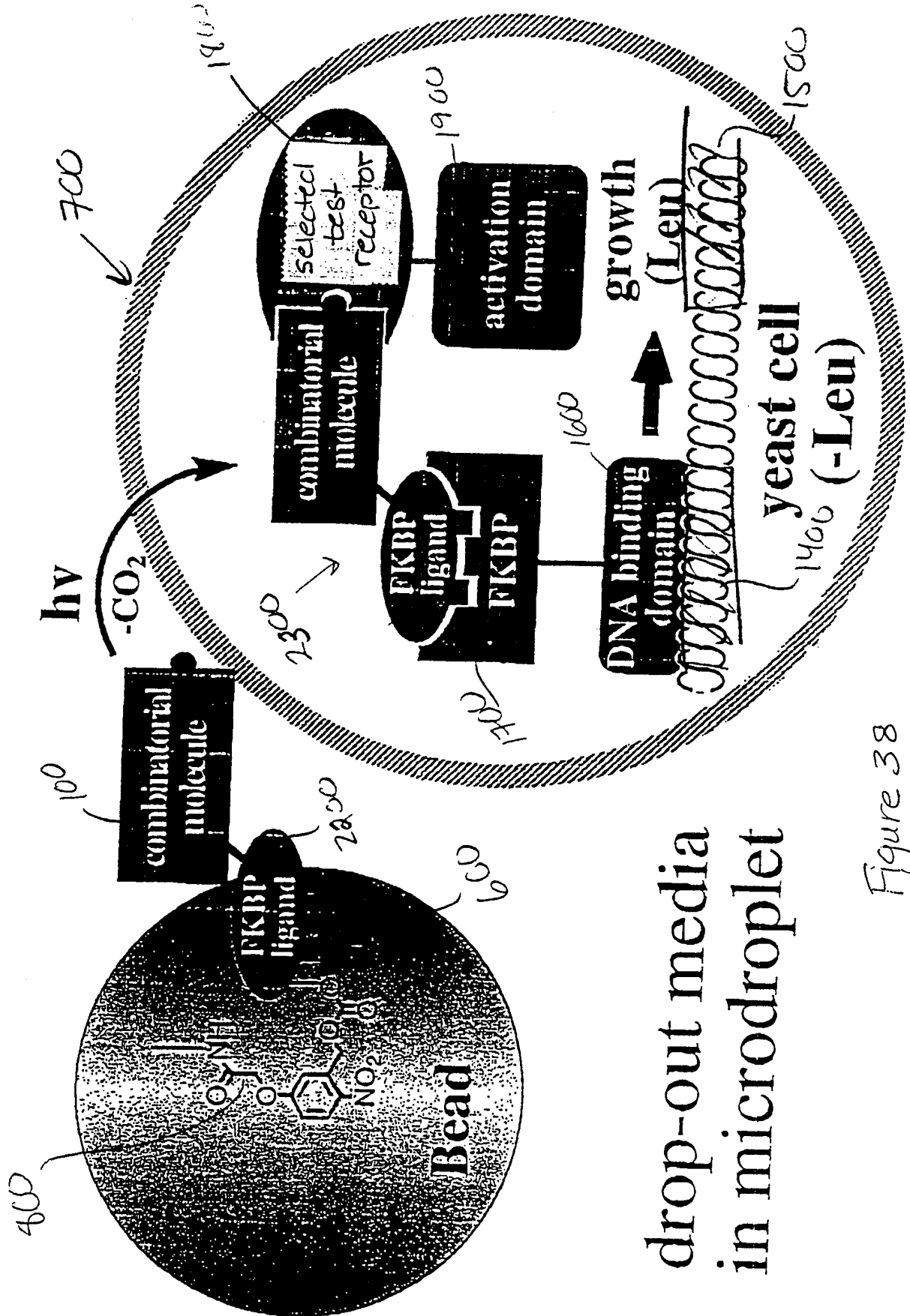
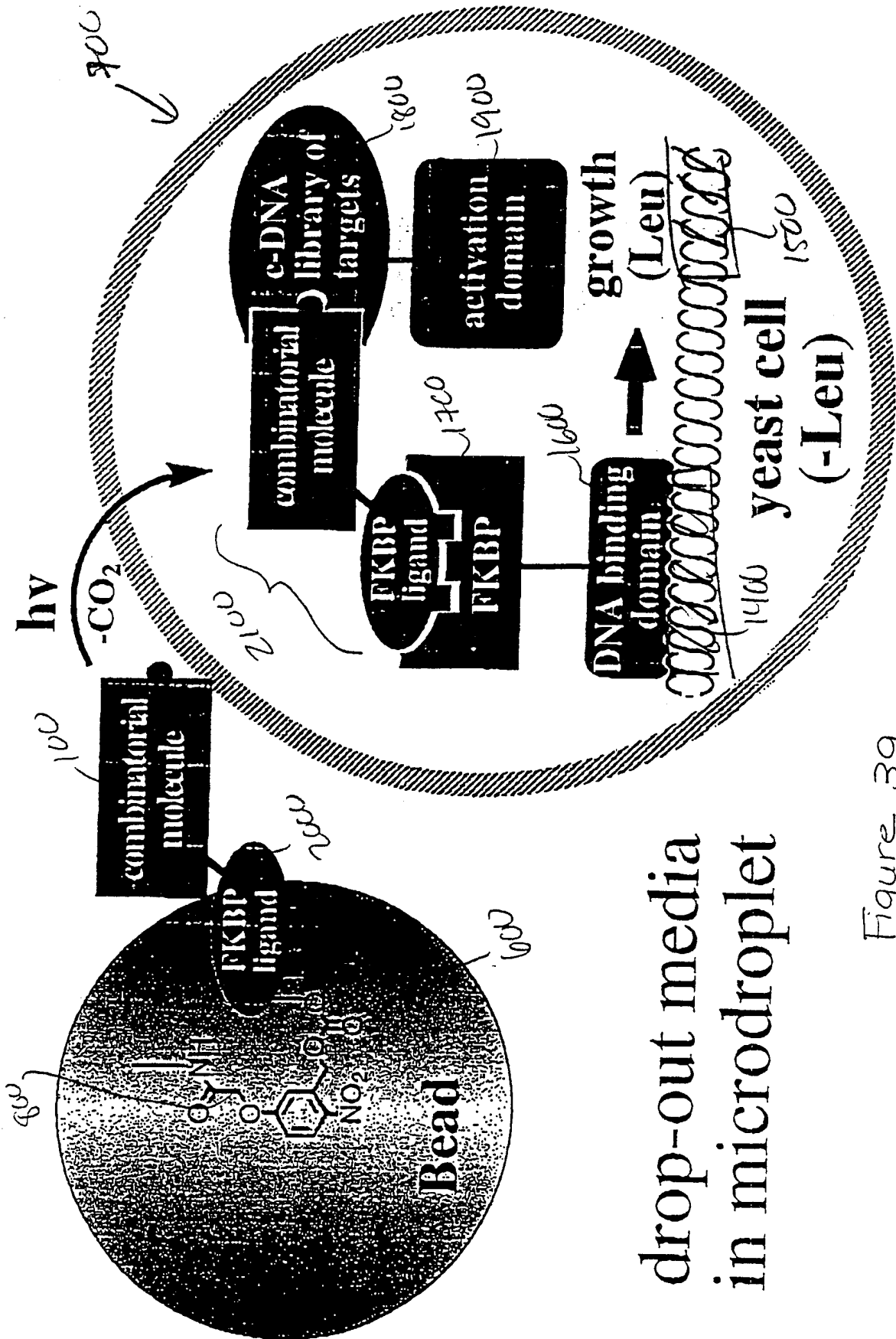

Figure 38



drop-out media
in microdroplet

Figure 39

Finding a Needle in the Haystack in the Haystack that Interacts with a Second Needle in a Second Haystack

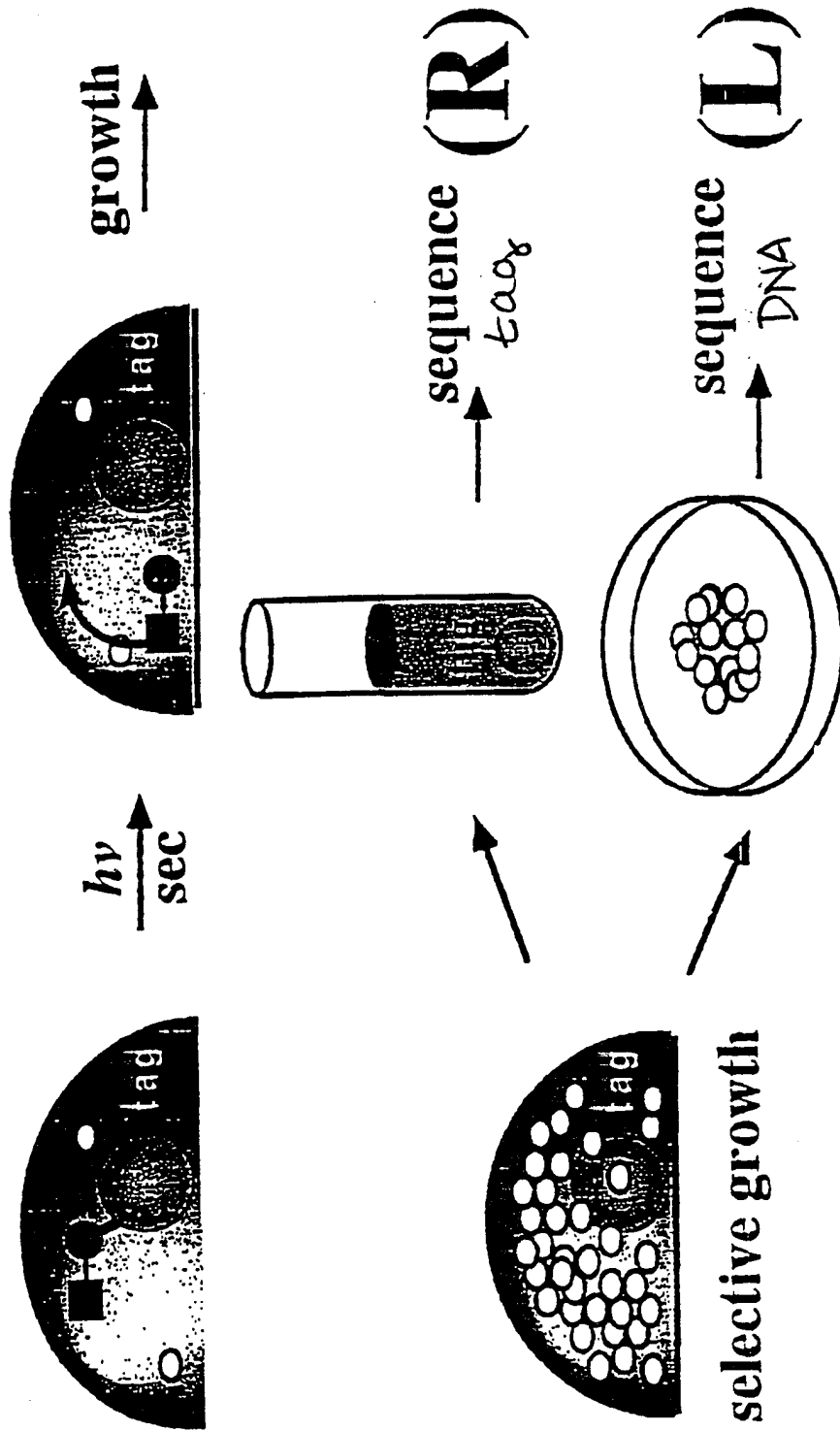

Figure 40

44 / 45

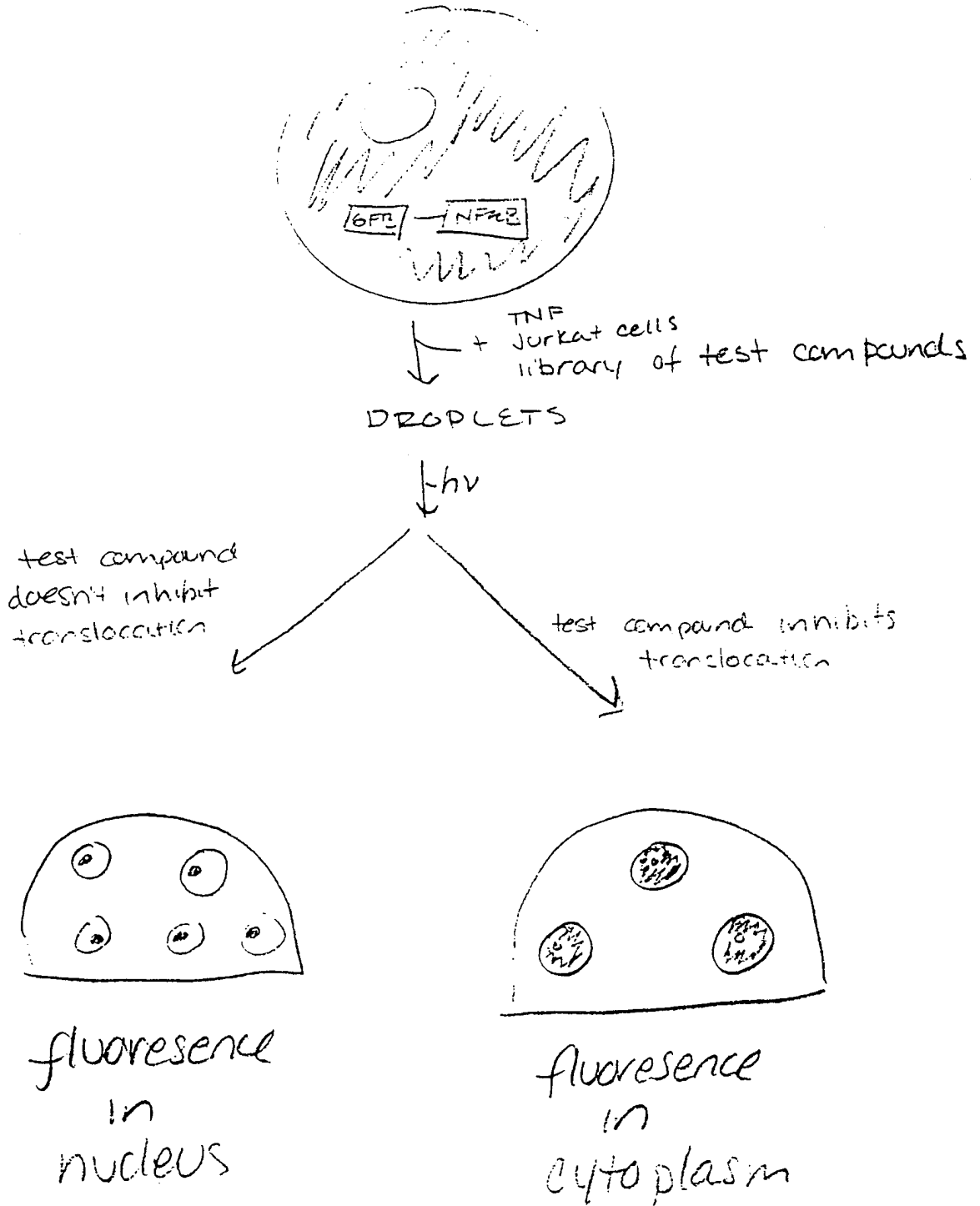

Figure 41

45 / 4 5

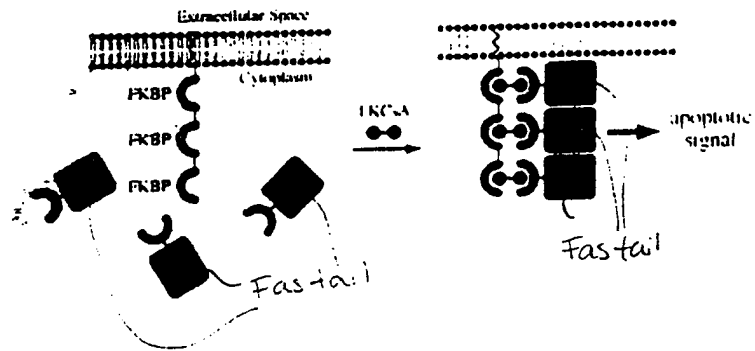

Figure 42