

(19)



(11)

EP 3 309 309 B1

(12)

EUROPEAN PATENT SPECIFICATION

(45) Date of publication and mention of the grant of the patent:
23.12.2020 Bulletin 2020/52

(51) Int Cl.:
E03F 5/04^(2006.01)

(21) Application number: **17205960.2**

(22) Date of filing: **23.11.2010**

(54) DRAIN COMPRISING A TUBULAR HOUSING AND A SIPHON

ABLAUF MIT ROHRFÖRMIGEM GEHÄUSE UND SIPHON

DRAIN AVEC BOITIER TUBULAIRE ET SIPHON

(84) Designated Contracting States:
AL AT BE BG CH CY CZ DE DK EE ES FI FR GB GR HR HU IE IS IT LI LT LU LV MC MK MT NL NO PL PT RO RS SE SI SK SM TR

(30) Priority: **23.11.2009 NL 2003844**

(43) Date of publication of application:
18.04.2018 Bulletin 2018/16

(62) Document number(s) of the earlier application(s) in accordance with Art. 76 EPC:
10192221.9 / 2 325 406

(73) Proprietor: **Easy Sanitary Solutions B.V.**
7575 BK Oldenzaal (NL)

(72) Inventor: **Keizers, Jurgen Hendrik Peter Joseph**
7575 BK Oldenzaal (NL)

(74) Representative: **'t Jong, Bastiaan Jacob**
Inaday Patent B.V.
Hengelosestraat 141
7521 AA Enschede (NL)

(56) References cited:
EP-A1- 1 865 117 EP-A1- 1 914 356
EP-A1- 1 947 253 EP-A1- 2 319 997
DE-U1-202005 019 964 DE-U1-202006 014 745
GB-A- 2 210 392 GB-A- 2 311 549

EP 3 309 309 B1

Note: Within nine months of the publication of the mention of the grant of the European patent in the European Patent Bulletin, any person may give notice to the European Patent Office of opposition to that patent, in accordance with the Implementing Regulations. Notice of opposition shall not be deemed to have been filed until the opposition fee has been paid. (Art. 99(1) European Patent Convention).

Description

[0001] The invention relates to a drain and a surrounding floor according to the preamble of claim 1. Such a drain and surrounding floor is known from DE 202006014745.

[0002] WO 2009/091245 describes an elongate shower drain. This shower drain has a gutter-like tray in which a grating of U-shaped cross-section is placed. According to this publication an adjusting frame is further placed in the lower tray so as to bring the grating to the same height as the surrounding tile floor in simple manner.

[0003] The trend in the field of drains is that the drain must be as little visible as possible. For this purpose the width of the grating is reduced. The drawback hereof is that by reducing the width of the grating the width of the lower tray is simultaneously also reduced. The buffer volume of the lower tray hereby decreases, whereby the quantity of water to be drained per unit of time decreases. The result may be that a layer of water remains on the floor which may spread over the floor surface in an undesired direction.

[0004] Another known elongate drain has at the position of the usual grating a tray-like holder in which a tile can for instance be laid. The water can then flow into the lower tray via a gap between this tile and the surrounding floor. In this tile drain a gap is usually formed on either side of the tray-like holder with tile. In addition, the pattern of tiles of the surrounding floor is disrupted by the tile in the holder, whereby such a known tile drain is also still visible. The construction of particularly the tile holder is in addition unfavourable from a manufacturing viewpoint.

[0005] GB 2210392 shows a drain wherein the drain consists of a lower part and an upper part. The upper part has a threaded part into which a part with a grating can be screwed. The grating can hereby be adjusted in the height. In addition, the upper part is slidable in the lower part, whereby the grating can also be adjusted in the horizontal plane.

[0006] The drawback of the shown embodiment is however that at least both the lower part and the upper part are cast into the floor before a finishing layer such as tiles can be arranged. This is because without casting of the upper part of the drain it is not possible to obtain a flat substrate for the purpose of arranging a finishing layer such as a tile layer.

[0007] It is now an object of the invention to provide a drain, wherein the above stated drawbacks are alleviated or even obviated.

[0008] This object is achieved with a drain and a surrounding floor according to claim 1.

[0009] In a drain and a surrounding floor according to the invention the tubular housing is integrated into the floor. The upper layer of the surrounding floor, such as for instance a tile floor, is laid over the tubular housing up to the elongate opening. Only an elongate opening is hereby visible. This elongate opening can be a narrow gap, since sufficient drainage capacity is present in the

tubular housing directly below the elongate opening.

[0010] Through the use of a tubular housing a flat upper surface is obtained, whereby the tile layer can be easily arranged.

5 **[0011]** The drain used in the invention comprises an upright edge arranged along the periphery of the elongate opening in the bottom surface. The tile floor is here laid against the upright edge arranged along the periphery of the elongate opening in the bottom surface. The upright edge provides for a boundary and a neat finish. The upright edge further ensures a good sealing because moisture can no longer get under the tiles.

10 **[0012]** It becomes possible with the tubular housing to make a very flat drain. The tubular housing can here be arranged in only a part of the covering floor, whereby it is not necessary to impair the system floor lying thereunder, for instance by hacking a hole in the system floor. A typical height of the tubular housing could be 1 to 2 centimetres.

20 **[0013]** The tubular housing can be arranged directly beneath for instance a tile floor since the floor load is low in sanitary applications.

25 **[0014]** In an embodiment of the drain used in the invention at least a part of the upright peripheral edge may be provided on the upper side with a part folded horizontally outward and an inward folded part connecting thereto, such that the upper side is provided with a horizontal flange of U-shaped cross-section.

30 **[0015]** A sealing membrane ensuring a watertight transition between the drain and the surrounding floor can easily be attached to the horizontal flange.

35 **[0016]** In a preferred embodiment of the drain used in the invention the upper surface is here the separate sheet part which protrudes with the peripheral edges into the horizontal flange of U-shaped cross-section. The separate sheet part is preferably arranged slidably in the horizontal flange.

40 **[0017]** Because the separate sheet part is arranged slidably in the horizontal flange, the position of the upright edge around the elongate opening can be readily adapted to the surrounding floor. It is thus possible to correct an askew placing of the tubular housing by rotating the upper surface relative to the flange. It is also possible by means of adjustment to have the inflow opening connect directly to a whole floor tile.

45 **[0018]** In the drain used in the invention the upper edge of the peripheral wall comprises an inward directed horizontal flange, which horizontal flange forms together with a separate sheet part the upper wall of the housing.

50 **[0019]** Spacers are preferably arranged on the underside of the separate sheet part in order to hold the separate sheet part at a distance from the bottom surface and against the horizontal flange.

55 **[0020]** This embodiment provides a drain wherein the inflow opening is slidable while the tubular housing is kept compact.

[0021] In a highly preferred embodiment of the drain used in the invention a closable inspection opening is

arranged in the upper surface above the discharge opening. This inspection opening preferably lies flush with the upper side of the upright edge. The inspection opening can be covered here with an aesthetically designed cap.

[0022] The width of the elongate opening in the upper surface is preferably less than 50%, and even more preferably less than 25%, of the width of the tubular housing.

[0023] In yet another embodiment of the drain used in the invention the separate sheet part is arranged slidably in the elongate opening. The width of the elongate inflow opening can be adjusted using this separate sheet part.

[0024] In yet another embodiment of the drain used in the invention the upper surface is stepped so that wall tiles can for instance be placed on the highest part. Such a drain is thus particularly suitable for arrangement against a wall.

[0025] These and other features of the invention are further elucidated with reference to the accompanying drawings.

Figure 1 is a perspective view of a first embodiment. Figure 2 shows a cross-sectional view of the embodiment according to figure 1.

Figure 3 shows a cross-sectional view of an embodiment according to the invention.

Figure 4 shows a cross-sectional view of an embodiment according to the invention.

Figure 5 shows a cross-sectional view of an embodiment according to the invention.

Figure 6 shows a cross-sectional view of an embodiment according to the invention.

Figure 7 shows a cross-sectional view of an embodiment according to the invention.

Figure 8 shows a cross-sectional view of an embodiment according to the invention.

[0026] Figure 1 shows a first embodiment of a drain 1. This drain 1 has a tubular housing constructed from an extruded central part 2 and two end parts 3, 4 which close the extruded central part 2 on either side. On the top side the extruded central part has two upright edges 5, 6 which bound the elongate inflow opening 7 (see figure 2).

[0027] Central part 2 has a bottom surface 8, a peripheral edge 9 and an upper surface 10 in which the elongate inflow opening 7 is arranged. Further arranged in bottom surface 8 is a discharge opening 11 to which a siphon 12 is connected.

[0028] Figure 2 shows drain 1 in cross-section. This figure 2 shows here how the drain is arranged in a concrete floor 13. Floor tiles 14 are arranged here on concrete floor 13. Floor tiles 14 are placed here right up to upright edges 5, 6, whereby only inflow opening 7 is visible.

[0029] In order to nevertheless retain access to siphon 12 an inspection opening 15 is arranged in upper surface 10. A plug 16 is arranged in this inspection opening 15. After removal of plug 16 easy access can be gained to discharge opening 11 via inspection opening 15.

[0030] Water falling onto tile floor 14 during use will flow via the elongate inflow opening 7 into tubular housing 2. Since the volume of tubular housing 2 is large, the water can flow without obstruction to discharge opening 11 and there be drained via siphon 12.

[0031] Figure 3 shows a cross-sectional view of a second embodiment 20 of a drain. This drain 20 is preferably manufactured from sheet material.

[0032] The lower tray of drain 20 has a bottom surface 21 and a peripheral wall 22. Arranged on the upper side of peripheral wall 22 is a horizontal flange which comprises an outward bent part 23 and a subsequent inward bent part 24 so that horizontal flange 23, 24 has a U-shaped cross-section.

[0033] Upper wall 25 of drain 20 is a separate part which protrudes into U-shaped horizontal flange 23, 24. It is hereby possible to slide the upper wall reciprocally.

[0034] An elongate inflow opening 26 is arranged in upper wall 25. An upright edge 27 is arranged along this inflow opening 26. Because upper wall 25 can slide reciprocally, the distance between upright edge 27 and a surrounding tile floor which can be laid on upper wall 25 can thus be adjusted.

[0035] A sealing membrane 28 can further be arranged on horizontal flange 23, 24. The edge of sealing membrane 28 is provided with a double edge, between which the horizontal flange can be received in order to thus obtain a good seal.

[0036] Figure 4 shows a third embodiment of a drain 40. This drain 40 is preferably also manufactured from sheet material. Drain 40 consists here of two parts, wherein the bottom part comprises a bottom wall 41, a peripheral wall 42 and an inward directed horizontal flange 43 arranged on the top side of peripheral wall 42.

[0037] The upper part of drain 40 consists of a wall part 44 held at a distance from bottom wall 41 by spacers 45. An elongate inflow opening 46 is further arranged in wall part 44. An upright edge 47 is further also arranged around this elongate inflow opening 46.

[0038] Because wall part 44 is narrower than the width of bottom part 41, 42, 43, wall part 44 can slide reciprocally so that inflow opening 46 can be adjusted to a floor, such as a tile floor, arranged on drain 40.

[0039] The wall tiles can be placed on flange 43. Upright edge 47 lies here against the wall tiles. The drain can then be sealed here relative to the wall tiles. Should moisture nevertheless enter between the wall tiles and upright edge 47, this moisture will still pass into the bottom part of drain 40. Wall part 44 can optionally also be provided with a perforation for a better drainage of such leaking liquid.

[0040] The above described perforations can also be applied in the other embodiments.

[0041] Figure 5 shows a fourth embodiment of a drain 50 according to the invention. The shown cross-section runs over outlet pipe 51. Drain 50 has a bottom surface 52 with a peripheral wall 53. Upper surface 54, 55, 56 is a combination of previously shown embodiments.

Formed on the one side is an inward bent flange 53 which co-acts with upper surface 54, while on the other side an inward bent flange is provided which co-acts with a flange 56 bent in a U-shape.

[0042] Upper surface 54, 55, 56 further has an inflow opening 57 which is bordered by upright edge 58.

[0043] Further arranged in bottom surface 52 is a discharge opening 59 to which connects a siphon constructed from a depending wall 60 and an upright wall 61. These two walls 60, 61 provide the necessary stench-trap.

[0044] Figure 6 shows a fifth embodiment of a drain 70 according to the invention. Drain 70 has a bottom surface 71 with an upright edge 72 and an inward directed flange 73. Together with wall part 74, flange 73 forms the upper wall of a tubular housing. Wall parts 74 are held at a distance from bottom surface 71 by means of spacers 75.

[0045] An adjusting frame 77, as known from for instance WO 2009/091245, is further arranged in inflow opening 76 which is formed between wall parts 74.

[0046] Because wall parts 74 can slide in horizontal direction relative to flanges 73 and adjusting frame 77 can in addition displace in vertical direction, the upper edge of adjusting frame 77 can thus be fully adapted to a surrounding floor, such as for instance a tiled floor.

[0047] Figure 7 shows a sixth embodiment of a drain 80 according to the invention. This drain 80 has a bottom surface 81, an upright peripheral wall 82 and an inward directed flange 83 on the upper side of peripheral wall 82.

[0048] Together with sheet parts 84, 85 this flange 83 forms the upper surface of a tubular housing. Sheet parts 84, 85 bound the elongate inflow opening 86.

[0049] A tile floor 87 is arranged on top of the tubular housing, whereby only the elongate inflow opening 86 is visible. The tubular housing is arranged in the upper part of a covering floor 88 arranged on a system floor 89.

[0050] A siphon 90 connected to an outlet pipe 91 is further also arranged on the underside of bottom surface 81. Only this siphon 90 and outlet pipe 91 are partially recessed into system floor 89.

[0051] Figure 8 shows a seventh embodiment of a drain 100. This drain 100 is particularly suitable for placing against a wall. For this purpose drain 100 is provided with a bottom surface 101 and a peripheral wall 102, 103. The part 102 of the peripheral wall which lies against a wall is higher than the other part 103 of the peripheral wall.

[0052] A horizontal flange 104 is arranged on the high part 102. A sealing membrane 105 and a finishing strip 106 are arranged on this flange. This finishing strip 106 can slide inward and outward on flange 104, whereby various adjustments can be made to the thickness of wall tiles 107. Wall tiles 107 are arranged on sealing membrane 105 and horizontal flange 104.

[0053] A horizontal flange 108, which together with a separate sheet part 109 forms the upper surface of a tubular housing, is likewise arranged on the low part 103 of the peripheral wall. The separate sheet part 109 can slide reciprocally so that the elongate inflow opening 110 can be adjusted in the width and can moreover be adapt-

ed to floor tiles 111.

[0054] The separate sheet part 109 has an upright edge which shields space 112 at the corner of the floor tile. The sealing compound arranged here is thus protected from cleaning agents and soap residues by the upright edge.

Claims

1. Drain (20; 40; 50; 70; 80; 100) and a surrounding floor (87, 88), which drain (20; 40; 50; 70; 80; 100) comprises a housing with a longitudinal direction, a bottom surface (21; 41; 52; 71; 81; 101) in which a discharge opening (59) is arranged, an upright peripheral edge (22; 42; 53; 72; 82; 102, 103) along the edge of the bottom surface (21; 41; 52; 71; 81; 101), and an elongate opening (26; 46; 57; 76; 86; 110), which elongate opening (26; 46; 57; 76; 86; 110) extends parallel to the longitudinal direction of the housing, the tubular housing being integrated into the surrounding floor (87, 88); and

- a siphon (60, 61; 90) arranged on the discharge opening (59) in the bottom surface (21; 41; 52; 71; 81; 101),

characterized in that

the housing is tubular having an upper surface (25; 44; 54; 74; 84; 104), wherein the elongate opening (26; 46; 57; 76; 86; 110) is arranged in the upper surface (25; 44; 54; 74; 84; 104); wherein the upper edge of the peripheral wall comprises an inward directed horizontal flange (24; 43; 55; 73; 83; 104), which horizontal flange (24; 43; 55; 73; 83; 104) forms together with a separate sheet part (25; 44; 54; 74; 84; 106, 109) the upper wall of the housing; and wherein the upper layer (14; 88) of the surrounding floor (13, 14; 87, 88) is laid over the tubular housing (2, 3, 4, 8, 9, 10) up to the elongate opening (7; 26; 46; 57; 76; 86; 110).

2. Drain and a surrounding floor according to claim 1, comprising an upright edge arranged along at least a part of the periphery of the elongate opening in the bottom surface.

3. Drain and a surrounding floor as claimed in claim 1 or 2, wherein at least a part of the upright peripheral edge is provided on the upper side with a part folded horizontally outward and an inward folded part connecting thereto, such that the upper side is provided with a horizontal flange of U-shaped cross-section.

4. Drain and a surrounding floor as claimed in claim 3, wherein the upper surface is the separate sheet part which protrudes with the peripheral edges into the horizontal flange of U-shaped cross-section.

5. Drain and a surrounding floor as claimed in claim 4, wherein the separate sheet part is arranged slidably in the horizontal flange.
6. Drain and a surrounding floor as claimed in claim 1, wherein spacers are arranged on the underside of the separate sheet part in order to hold the separate sheet part at a distance from the bottom surface and against the horizontal flange.
7. Drain and a surrounding floor as claimed in any of the foregoing claims, wherein a closable inspection opening is arranged in the upper surface above the discharge opening.
8. Drain and a surrounding floor as claimed in any of the foregoing claims, wherein the separate sheet part is arranged slidably in the elongate opening.
9. Drain and a surrounding floor as claimed in any of the foregoing claims, wherein the upper surface is stepped so that wall tiles can for instance be placed on the highest part.

Patentansprüche

1. Abfluss (20; 40; 50; 70; 80; 100) und umgebender Fußboden (87, 88), wobei der Abfluss (20; 40; 50; 70; 80; 100) ein Gehäuse mit einer Längsrichtung, eine Bodenfläche (21; 41; 52; 71; 81; 101) in der eine Auslassöffnung angeordnet ist, eine hochstehende Umfangskante (22; 42; 53; 72; 82; 102, 103) entlang der Kante der Bodenfläche (21; 41; 52; 71; 81; 101) und eine längliche Öffnung (26; 46; 57; 76; 86; 110) umfasst, wobei sich die längliche Öffnung (26; 46; 57; 76; 86; 110) parallel zu der Längsrichtung des Gehäuses erstreckt, wobei das rohrförmige Gehäuse in den umgebenden Fußboden (87, 88) integriert ist; und
 - einen Siphon (60, 61; 90), der auf der Auslassöffnung (59) in der Bodenfläche (21; 41; 52; 71; 81; 101) angeordnet ist,**dadurch gekennzeichnet, dass**
 das Gehäuse rohrförmig ist, eine obere Fläche (25; 44; 54; 74; 84; 104) aufweist, wobei die längliche Öffnung (26; 46; 57; 76; 86; 110) in der oberen Fläche (25; 44; 54; 74; 84; 104) angeordnet ist;
 wobei die obere Kante der Umfangswand einen nach innen gerichteten horizontalen Flansch (24; 43; 55; 73; 83; 104) umfasst, wobei der horizontale Flansch (24; 43; 55; 73; 83; 104) gemeinsam mit einem getrennten Folienteil die obere Wand des Gehäuses bildet; und
 wobei die obere Schicht (14; 88) des umgebenden Fußbodens (13, 14; 87, 88) oberhalb des

rohrförmigen Gehäuses (2, 3, 4, 8, 9, 10) bis zur länglichen Öffnung (7; 26; 46; 57; 76; 86; 110) gelegen ist.

2. Abfluss und umgebender Fußboden nach Anspruch 1, die eine hochstehende Kante umfassen, die entlang mindestens eines Teils des Umfangs der länglichen Öffnung in der Bodenfläche angeordnet ist.
3. Abfluss und umgebender Fußboden nach Anspruch 1 oder 2, wobei mindestens ein Teil der hochstehenden Umfangskante auf der oberen Seite mit einem Teil bereitgestellt ist, das horizontal nach außen gefaltet ist, und einem nach innen gefalteten horizontalen Teil, das damit derart verbunden ist, dass die obere Seite mit einem horizontalen Flansch mit einem U-förmigen Querschnitt bereitgestellt ist.
4. Abfluss und umgebender Fußboden nach Anspruch 3, wobei die obere Fläche das getrennte Folienteil ist, welches mit den Umfangskanten in den horizontalen Flansch mit einem U-förmigen Querschnitt hervorspringt.
5. Abfluss und umgebender Fußboden nach Anspruch 4, wobei das getrennte Folienteil verschiebbar in dem horizontalen Flansch angeordnet ist.
6. Abfluss und umgebender Fußboden nach Anspruch 1, wobei Abstandhalter an der Unterseite des getrennten Folienteils angeordnet sind, um das getrennte Folienteil auf einem Abstand von der Bodenfläche und gegen den horizontalen Flansch zu halten.
7. Abfluss und umgebender Fußboden nach einem der vorstehenden Ansprüche, wobei eine schließbare Inspektionsöffnung in der oberen Fläche über der Auslassöffnung angeordnet ist.
8. Abfluss und umgebender Fußboden nach einem der vorstehenden Ansprüche, wobei das getrennte Folienteil verschiebbar in der länglichen Öffnung angeordnet ist.
9. Abfluss und umgebender Fußboden nach einem der vorstehenden Ansprüche, wobei die obere Fläche derart gestuft ist, dass Wandfliesen zum Beispiel auf dem höchsten Teil platziert werden können.

Revendications

1. Bouche d'écoulement (20 ; 40 ; 50 ; 70 ; 80 ; 100) et plancher environnant (87, 88), laquelle bouche d'écoulement (20 ; 40 ; 50 ; 70 ; 80 ; 100) comprend un boîtier avec une direction longitudinale, une surface inférieure (21 ; 41 ; 52 ; 71 ; 81 ; 101) dans la-

quelle une ouverture de décharge (59) est agencée, un bord périphérique vertical (22 ; 42 ; 53 ; 72 ; 82 ; 102, 103) le long du bord de la surface inférieure (21 ; 41 ; 52 ; 71 ; 81 ; 101) et une ouverture allongée (26 ; 46 ; 57 ; 76 ; 86 ; 110), laquelle ouverture allongée (26 ; 46 ; 57 ; 76 ; 86 ; 110) s'étend parallèlement à la direction longitudinale du boîtier, le boîtier tubulaire étant intégré dans le plancher environnant (87, 88) ; et

- un siphon (60, 61 ; 90) agencé sur l'ouverture de décharge (59) dans la surface inférieure (21 ; 41 ; 52 ; 71 ; 81 ; 101),

caractérisés en ce que

le boîtier est tubulaire avec une surface supérieure (25 ; 44 ; 54 ; 74 ; 84 ; 104), dans laquelle l'ouverture allongée (26 ; 46 ; 57 ; 76 ; 86 ; 110) est agencée dans la surface supérieure (25 ; 44 ; 54 ; 74 ; 84 ; 104) ;

dans lesquels le bord supérieur de la paroi périphérique comprend une bride horizontale dirigée vers l'intérieur (24 ; 43 ; 55 ; 73 ; 83 ; 104), laquelle bride horizontale (24 ; 43 ; 55 ; 73 ; 83 ; 104) forme ensemble avec une partie en feuille séparée (25 ; 44 ; 54 ; 74 ; 84 ; 106, 109) la paroi supérieure du boîtier ; et

dans lesquels la couche supérieure (14 ; 88) du plancher environnant (13, 14 ; 87, 88) repose sur le boîtier tubulaire (2, 3, 4, 8, 9, 10) jusqu'à l'ouverture allongée (7 ; 26 ; 46 ; 57 ; 76 ; 86 ; 110).

2. Bouche d'écoulement et un plancher environnant selon la revendication 1, comprenant un bord vertical agencé le long d'au moins une partie de la périphérie de l'ouverture allongée dans la surface inférieure.
3. Bouche d'écoulement et plancher environnant selon la revendication 1 ou 2, dans lesquels au moins une partie du bord périphérique vertical est prévue sur le côté supérieur avec une partie repliée horizontalement vers l'extérieur et une partie repliée vers l'intérieur reliée à celle-ci, de sorte que le côté supérieur est muni d'une bride horizontale de section transversale en forme de U.
4. Bouche d'écoulement et plancher environnant selon la revendication 3, dans lesquels la surface supérieure est la partie en feuille séparée qui avance avec les bords périphériques dans la bride horizontale de section transversale en forme de U.
5. Bouche d'écoulement et plancher environnant selon la revendication 4, dans lesquels la partie en feuille séparée est agencée à coulissement dans la bride horizontale.
6. Bouche d'écoulement et plancher environnant selon

la revendication 1, dans lesquels des pièces d'écartement sont agencées sur le dessous de la partie en feuille séparée afin de maintenir la partie en feuille séparée à une certaine distance de la surface inférieure et contre la bride horizontale.

7. Bouche d'écoulement et plancher environnant selon l'une quelconque des revendications précédentes, dans lesquels une ouverture d'inspection refermable est agencée dans la surface supérieure au-dessus de l'ouverture de décharge.
8. Bouche d'écoulement et plancher environnant selon l'une quelconque des revendications précédentes, dans lesquels la partie en feuille séparée est agencée à coulissement dans l'ouverture allongée.
9. Bouche d'écoulement et plancher environnant selon l'une quelconque des revendications précédentes, dans lesquels la surface supérieure est étagée de sorte que des dalles formant paroi peuvent par exemple être placées sur la partie la plus élevée.

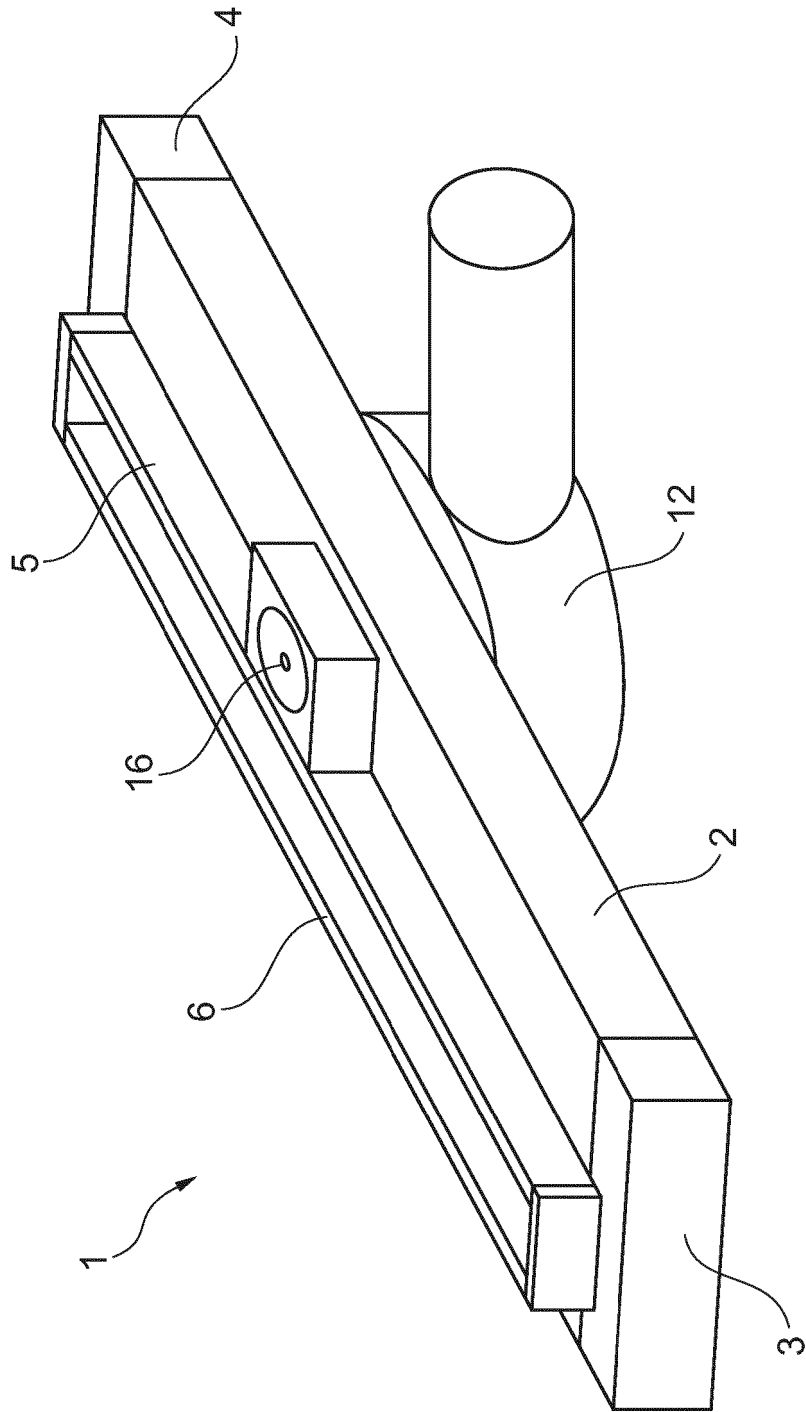

Fig. 1

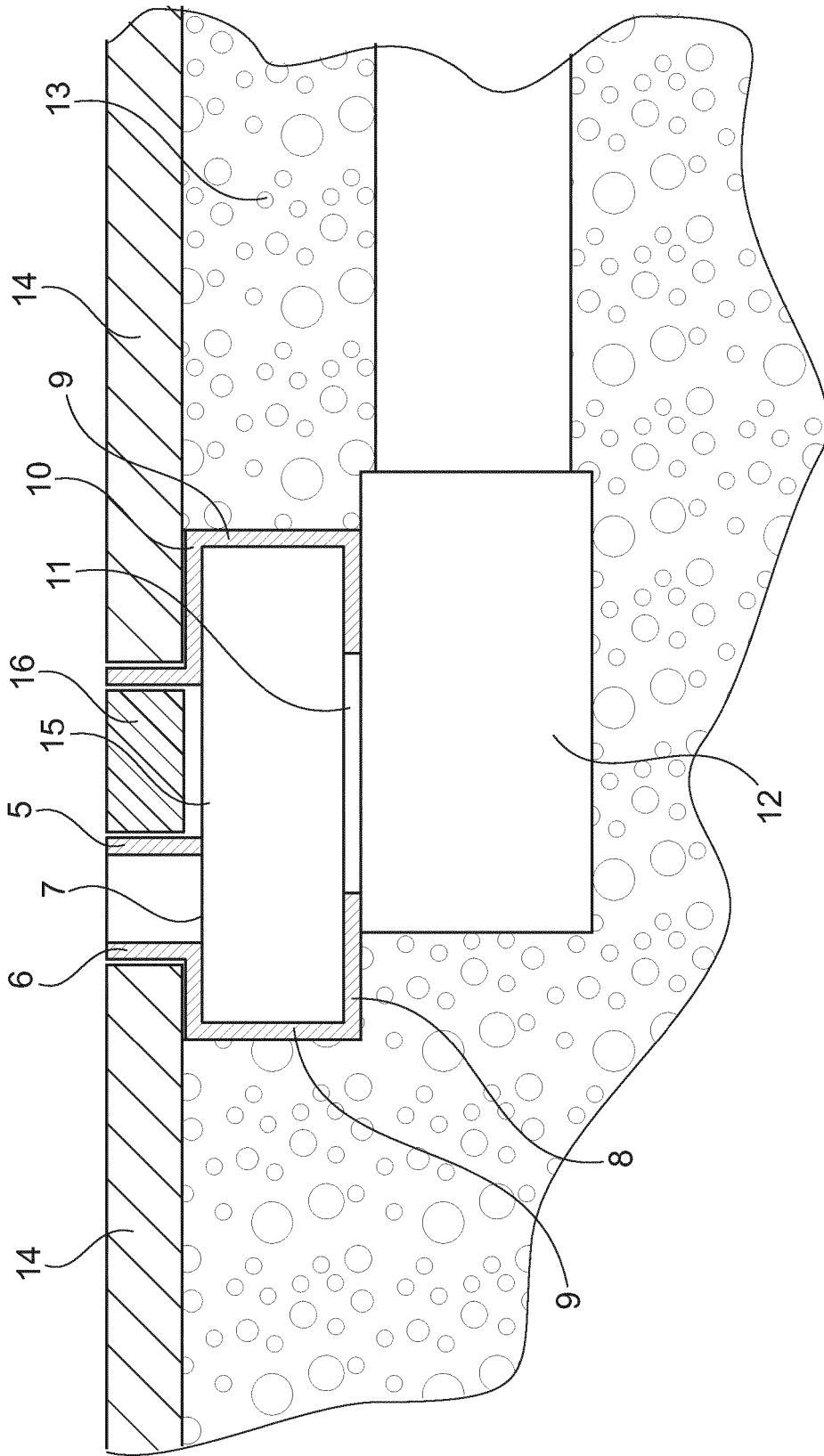

Fig. 2

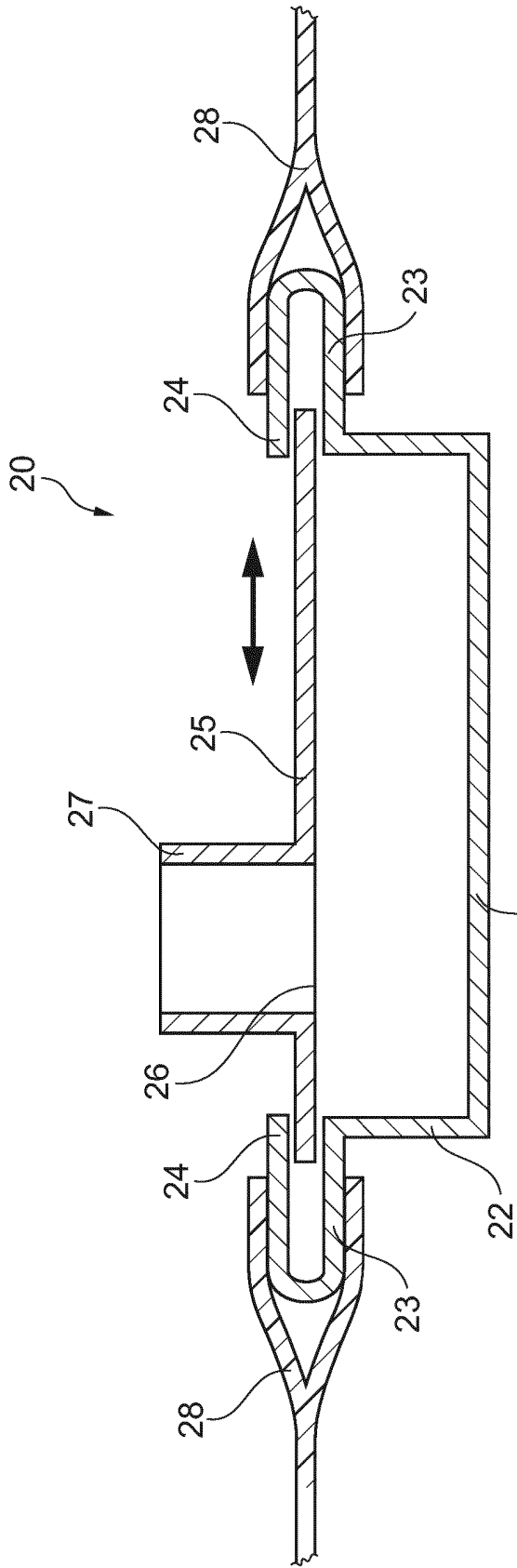

Fig. 3

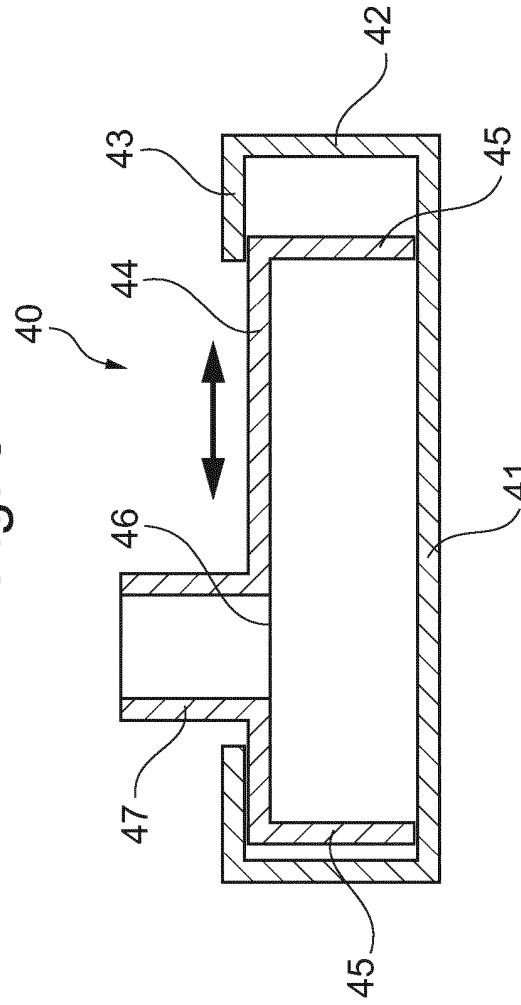

Fig. 4

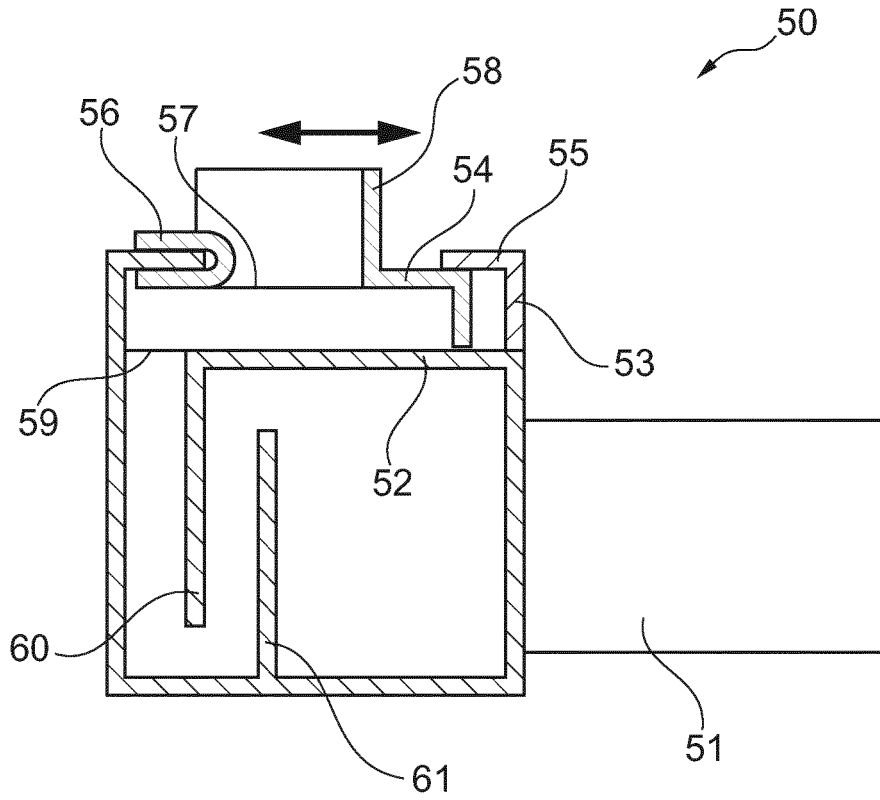

Fig. 5

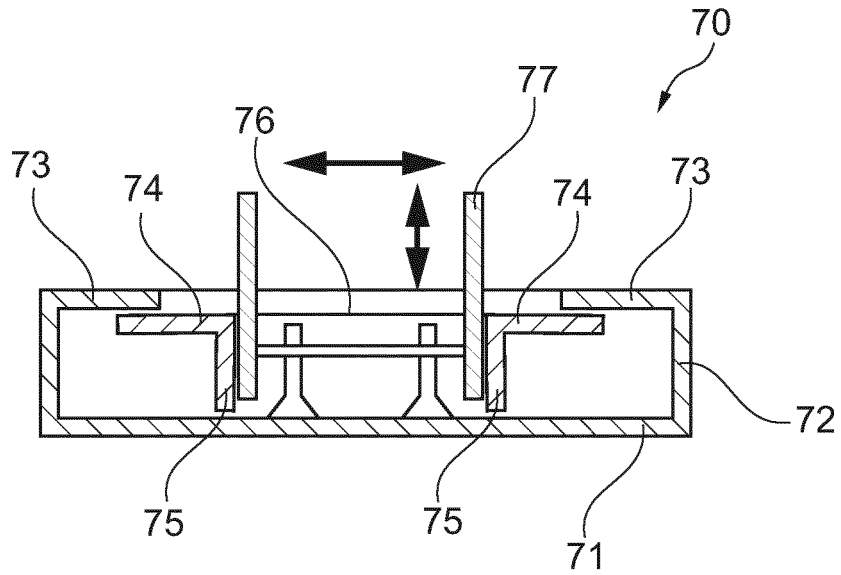

Fig. 6

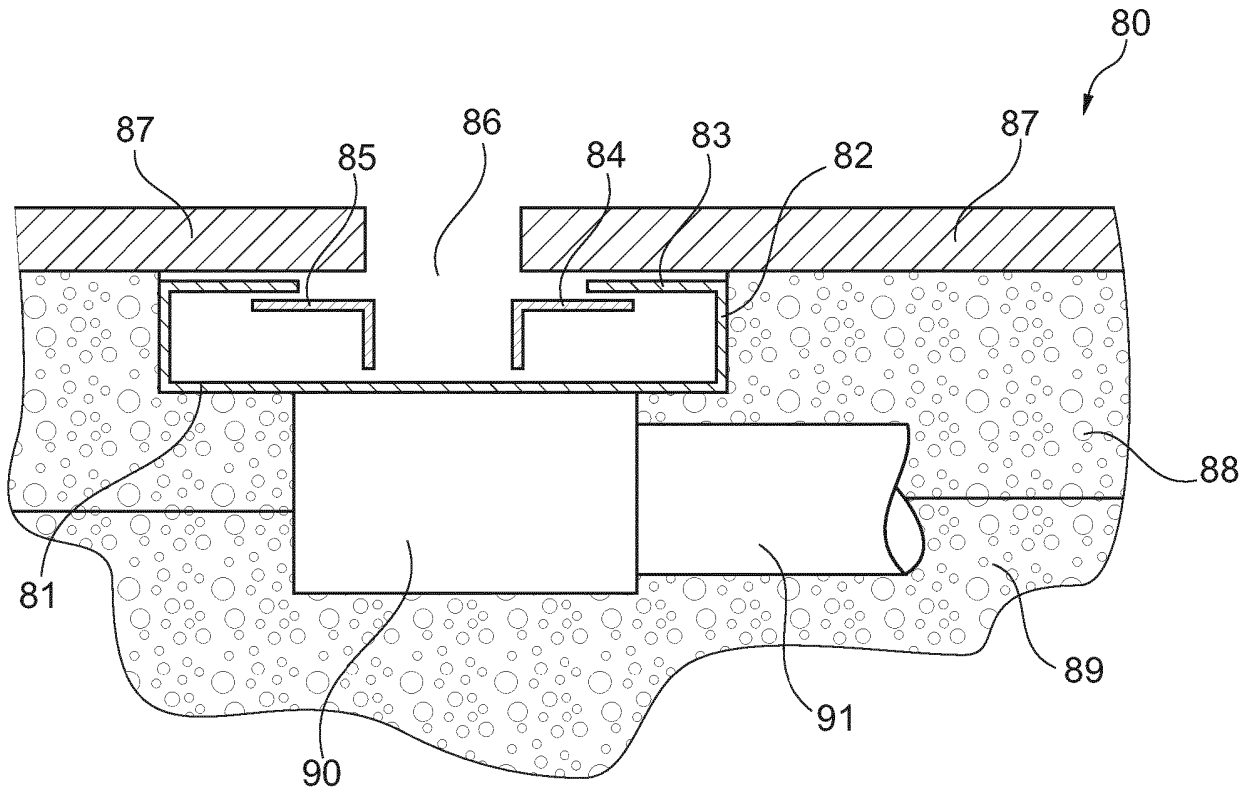

Fig. 7

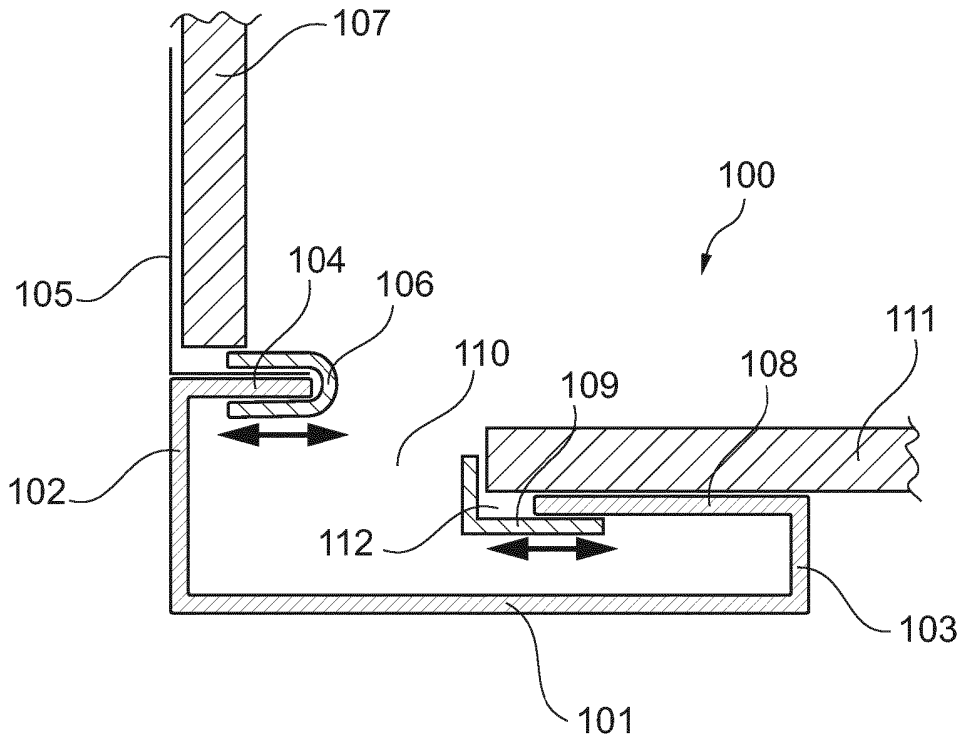

Fig. 8

REFERENCES CITED IN THE DESCRIPTION

This list of references cited by the applicant is for the reader's convenience only. It does not form part of the European patent document. Even though great care has been taken in compiling the references, errors or omissions cannot be excluded and the EPO disclaims all liability in this regard.

Patent documents cited in the description

- DE 202006014745 [0001]
- WO 2009091245 A [0002] [0045]
- GB 2210392 A [0005]