

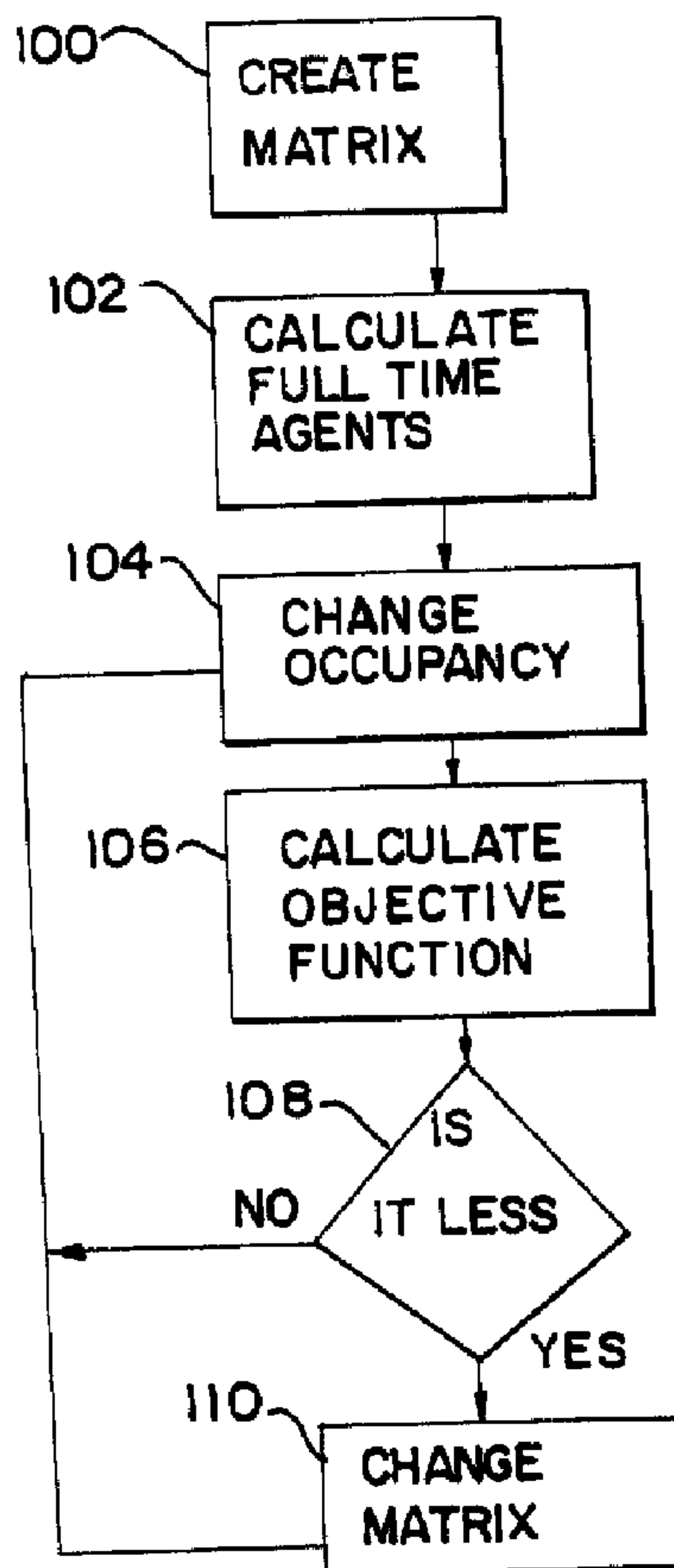

(22) Date de dépôt/Filing Date: 2000/04/17
 (41) Mise à la disp. pub./Open to Public Insp.: 2000/10/27
 (45) Date de délivrance/Issue Date: 2007/08/28
 (30) Priorité/Priority: 1999/04/27 (US09/300,676)

(51) Cl.Int./Int.Cl. *H04Q 3/64* (2006.01),
H04M 3/523 (2006.01), *H04M 3/36* (2006.01)
 (72) Inventeurs/Inventors:
DOYLE, ROBERT, US;
WILLIAMS, LAIRD C., US;
FERTIG, KENNETH W., US;
UCKUN, N. SERDAR, US;
WANG, XUEMEI, US
 (73) Propriétaire/Owner:
ROCKWELL ELECTRONIC COMMERCE
TECHNOLOGIES, LLC, US
 (74) Agent: MBM & CO.

(54) Titre : ACHEMINEMENT D'APPELS DYNAMIQUE FONDE SUR LES HABLETES
 (54) Title: DYNAMIC SKILL-BASED CALL ROUTING



(57) Abrégé/Abstract:

A method and apparatus are provided for assigning agents of an automatic call distributor to incoming calls of a plurality of call types handled by the automatic call distributor. The method includes the steps of determining a target occupancy matrix including a

(57) **Abrégé(suite)/Abstract(continued):**

target occupancy for each agent of the agents of the automatic call distributor for each call type of the plurality of call types. The method further includes the steps of processing a call of a first type of the types determined in the target occupancy matrix and assigning the call to an agent of the agents of the automatic call distributor with a largest relative difference between an actual occupancy of calls of the first type handled by the agent and the target occupancy of calls of the first type determined for the agent in the target occupancy matrix.

Abstract

A method and apparatus are provided for assigning agents of an automatic call distributor to incoming calls of a plurality of call types handled by the automatic call distributor. The method includes the steps of determining a target occupancy matrix including a target occupancy for each agent of the agents of the automatic call distributor for each call type of the plurality of call types. The method further includes the steps of processing a call of a first type of the types determined in the target occupancy matrix and assigning the call to an agent of the agents of the automatic call distributor with a largest relative difference between an actual occupancy of calls of the first type handled by the agent and the target occupancy of calls of the first type determined for the agent in the target occupancy matrix.

20

DYNAMIC SKILL-BASED CALL ROUTING

5

Field of the Invention

The field of the invention relates to telephony systems and more particularly to automatic call distributors used with private networks.

10

Background of the Invention

Automatic call distribution systems are known. Such systems are typically used in an organizational context as a means of distributing telephone calls among a group of agents of the organization. Agents are typically segregated into groups to serve particular call targets within an organization.

Often the organization disseminates a single telephone number to its customers and to the public in general as a means of contacting the organization. As calls are directed to the organization from the public switch telephone network (PSTN), the automatic call distribution system directs the calls to its agents based upon some algorithm, typically based upon availability. For example, where all agents are considered equal, the automatic call distributor (ACD) may distribute the calls based upon which agent position (telephone) has been idle the longest.

In other systems, where skill is considered essential for call handling, a call may be directed to an agent (or agent group) considered the most skilled for the call considered. In these systems, a database of customer records is maintained. Customers are identified to the ACD and database by features such as automatic number identifier (ANI).

In order to staff an ACD, an organization often relies on historical levels (in Erlangs) of incoming calls to the individual call targets. A manager of the ACD may examine the historical call loading records, add or subtract a percentage of the historical loading based upon a most recent call history (e.g., the most recent week or month), and estimate a staffing level based upon those calculations. Alternatively, some organizations have relied upon commercially available predictive software (i.e., force management packages) which calculates daily staffing levels based upon historic information.

Once daily staffing levels have been estimated, agents are scheduled based upon those estimates. Where more than one organizational call target is involved (e.g., sales agents, service agents, outgoing call campaign agents, etc.), requiring different agent skills, each group is separately staffed based upon an Erlang estimate for that group.

As an alternative to staffing individual groups, some systems group all agents together and assign a skill rating to each agent. Calls are then assigned based upon the skill rating of the agent for handling that type of call.

For example, where a single group is used, an ACD will always look for and assign the call to the most qualified agent. However, some agents are more qualified than others. Because of the differences in qualifications, some agents receive more calls than others, resulting in an inequitable work load.

Further, where all agents are grouped together, an Erlang rate for any one group becomes irrelevant. For example, one benefit of using a common group relates to economies of scale. Two separate groups

that separately require 10 agents each would typically only require 18 agents from a common pool of agents.

Further, it is difficult, if not impossible for
5 call center management to know how many agents are serving a particular call target. Because of the difficulty of determining agent loading, it is also difficult to project staffing requirements in a shared agent environment.

10 Where all agents are grouped together, staffing estimates must be based upon an Erlang rate of the organization as a whole. Basing a staffing estimate upon an organization as a whole is subject to large errors. Because of the importance of call handling
15 through ACDs, a need exists for a method of assigning agents which is more flexible than the individual group method, but which may still be staffed based upon Erlang estimates of the individual call groups.

20

Summary

A method and apparatus are provided for assigning agents of an automatic call distributor to incoming calls of a plurality of call types handled by the automatic call distributor. The method
25 includes the steps of determining a target occupancy matrix including a target occupancy for each agent of the agents of the automatic call distributor for each call type of the plurality of call types. The method further includes the steps of processing a call of a
30 first type of the types determined in the target occupancy matrix and assigning the call to an agent of the agents of the automatic call distributor with a largest relative difference between an actual occupancy of calls of the first type handled by the
35 agent and the target occupancy of calls of the first

type determined for the agent in the target occupancy matrix.

Brief Description of the Drawings

5 FIG. 1 is a block diagram of an ACD system in accordance with an illustrated embodiment of the invention; and

FIG. 2 is a flow chart of process steps that may be used by the system of FIG. 1.

10 Appendix I is an unpublished paper entitled "AUTOMATIC GENERATION OF AGENT OCCUPANCY MATRIX: REQUIREMENTS AND ALGORITHM DESCRIPTION" that describes (in pseudo-code and otherwise) an algorithm that may be used by the system of FIG. 1.

15

Detailed Description of a Preferred Embodiment

FIG. 1 is a block diagram of an ACD system 10, generally, using skill based call routing under an illustrated embodiment of the invention. Under the
20 embodiment, the ACD 18 may receive calls over a number of trunk lines 28 through the PSTN 16 from customers 12, 14 of the ACD 18. Along with the calls, the ACD 18 may receive information about the calls from the PSTN 18. For example, the ACD 18 may
25 receive an identifier of a caller from an automatic number identification (ANI) service operating from within the PSTN 16. The ACD 18 may also receive information about a dialed number through a dialed number identification (DNIS) service or direct inward
30 dial (DID) information from the PSTN 16.

The ACD 18 may also be programmed to place calls at the same time as it receives calls. For example, the ACD 18 may conduct an outgoing call campaign to existing or potential customers at the same time as

it receives calls from existing or potential customers.

In the case of outgoing calls, a list of telephone numbers (i.e., call targets) may be entered through the PC 11 and sequentially transferred to the ACD 18. Upon receipt of a call target, the ACD 18 may seize a trunk line of the trunks 28 and transfer the target telephone number to the PSTN 16. When the target answers, the ACD 18 connects the target to an agent.

In the case of an outgoing call, the PC 11 may transfer an identifier of the call target to the ACD 18. Alternatively, the ACD 18 (e.g., by reference to a database) may determine an identity of the call target based upon the dialed number.

From the information received from the PSTN 16 (or PC 11), the ACD 18 may classify the call as a particular work type based upon the identity of the call target and whether it is an inbound or outbound call. For example, the ACD 10 may be owned and operated by a department store. Individual call targets may include women's clothing, men's clothing, footwear, housewares, appliances, electronics, furniture, hardware, automotive and garden. Other internal call targets may include catalog sales or technical support for one or more of the other call targets.

As opposed to creating semi-permanent groups of agents and queuing calls to the appropriate group, the ACD 18 places agents in a single pool and directs all calls to this pool. Agents are rated according to skill level in each call type. A target agent responsibility (occupancy) matrix is created to allocate portions of agents' time to each call type, based on the agent skill in handling that call type,

as well as call type workload and other enterprise-related factors. Table I is a simplified example of a target occupancy matrix.

TABLE I

	Tocc(j)	WORK TYPE #1	WORK TYPE #2	WORK TYPE #3
AGENT #1	85%	10%	60%	15%
AGENT #2	50%	20%	20%	10%
AGENT #3	90%	30%	30%	30%
AGENT #4	90%	70%	10%	10%

5

FIG. 2 is a flow chart that may be followed in creating the target occupancy matrix. Reference will be made to FIG. 2 as appropriate to an understanding of the invention.

10

In the over-staffed situation (agents available when a call arrives), the call is handled by the agent whose actual occupancy is furthest from the target occupancy for that call type. Actual occupancy may be defined as the amount of time an agent has spent on a particular work type divided by a time of a reporting period (e.g., a workshift) and expressed as a percentage. Table II is an example of an actual occupancy matrix.

15

TABLE II

	Tocc(j)	WORK TYPE #1	WORK TYPE #2	WORK TYPE #3
AGENT #1	85%	10%	50%	15%
AGENT #2	50%	19%	20%	10%
AGENT #3	90%	27%	30%	25%
AGENT #4	90%	50%	10%	10%

Where a call comes in (e.g., for work type #1) a comparison is made of the deviation of each agent from the target occupancy for that work type. As may be seen by comparing Tables I and II, agent #4 has a target occupancy for work type #1 of 70% and an actual occupancy for work type #1 of 50%. Since agent #4 has the greatest deviation, the next call of work type #1 would go to agent #4.

In the understaffed situation (no agents available and calls are queued), a call will be selected from the queue of a work type which will bring an available agent's actual occupancy level closest to the target for that agent. If there is more than one call of that work type, then the call with the highest priority or the longest time in queue may be chosen.

The system may be used to provide real-time reporting in the form of a display of actual versus target agent occupancy for each call type, and provides a mechanism for adjusting the targets. This solution has the advantage that it gives call center management, working through the PC 11 (hereinafter referred to as the "user"), a mechanism for easy control over agent assignments in the form of target occupancies, and it provides uniform agent utilization where desired.

Under the illustrated embodiment, each agent is evaluated and assigned a skill level for his proficiency in any number of skills related to servicing calls directed to each particular type of call target. An agent may be assigned a skill level expressed as any number between 1.0 and 2.0 (i.e., where 2.0 indicates the highest level of proficiency), in increments of 0.1. Table III is an

example of a skills matrix that may be used to classify agents.

TABLE III

	ENGLISH	SPANISH	WOMENS CLOTHING	MENS CLOTHING	FOOTWEAR
AGENT #1	1.1	0.0	1.5	1.9	1.3
AGENT #2	1.9	1.3	1.5	1.1.	1.8
AGENT #3	1.5	1.5	1.7	1.2	0.0

5

Agent proficiency may be regarded as one example of semi-permanent data that may be used by the PC 11 in creating a target occupancy matrix. Permanent and variable data may also be used.

Permanent data may include a list of skill types required for each work type. A list may also be provided of the work types handled by the system 10. A minimum skill level may be included for each skill required for each work type. A priority number may be provided for each work type.

Variable data may include a target total agent occupancy ($Tocc(i)$) for each agent i . For example, an agent may have a target total agent occupancy of 85, 95 or even 100%. Further, the variable data may include one or more target agent occupancies for the particular work types.

Variable data may also include an expected call load for each work type. The expected load may be in Erlangs. The variable data may also include a list of agents scheduled to work during any time period.

Once the permanent, semi-permanent and variable data have been provided to the PC 11, the PC 11 may form an initial target occupancy matrix. In forming an initial target matrix, the PC 11 must determine

whether an agent is qualified to be given an occupancy value for any particular work type within the target matrix.

To determine the suitability of an agent for a work type, the PC 11 evaluates each agent's qualifications with regard to the work type. Each agent i must possess a skill level which exceeds a minimum level required by the work type. In effect, the skill $ASkl(i,k)$ of agent i for skill k must exceed the skill requirement $WSkl(j,k)$ for work type j in skill k . Further, any particular work type may require a skill set including more than one evaluated skill. Stated differently, for an agent to be assigned to a work type, $ASkl(i,k) \geq WSkl(j,k)$ for all k .

In the example of Table II, a call from/to a particular geographic area may be known to include a large Spanish population. Calls regarding a telephone number associated with this area regarding footwear would require at least two skills (i.e., the ability to speak Spanish as well as a knowledge of footwear). A minimum skills level may be required in each skill.

To evaluate an agent for a work type where multiple skills are required, the PC 11 solves for the euclidean distance $ACap(i,j)$ between the agent i 's skills and work type j 's requirements. Expressed differently, the PC 11 solves the equation as follows:

30

$$ACap(i, j) = \sqrt{\sum_k (ASkl(i, j) - WSkl(j, k))^2}, (WSkl(j, k) > 0).$$

If for any k , such that $ASkl(i,k) < WSk1(j,k)$ (i.e., agent i does not satisfy the minimum skill requirements of work type j), then

$$5 \quad ACap(i,j) = -\sqrt{\sum (ASkl(i,k) - WSk1(j,k))^2, (WSkl(j,k) > ASkl(i,k))}.$$

Expressed differently, where $Acap(i,j) \geq 0$, the agent may be regarded as qualified for the work type.

Where $Acap(i,j) < 0$, the agent may not be regarded as
10 qualified for the work type.

Once the capability of each agent is determined, the PC 11 may form 100 an initial target matrix. To populate the matrix, the PC 11 may first retrieve a set of occupancy values entered by the user. For
15 example, the user may enter a total occupancy $Tocc(i)$ for a particular agent i over all work types. The user may also enter an occupancy value (" $X(i,j)$ ") for the agent i regarding one or more work types j . Ultimately, the user could specify the entire scope
20 of the initial target matrix, but this is not necessary since the PC 11 will supply occupancy values where necessary.

Further, as will be discussed below, the user may designate some agents as primary agents for a
25 work type. Other agents may be designated, or may become, secondary agents.

Where an agent is to be designated as a primary agent of a work type, that agent would be expected to have a higher occupancy rating for the work type,
30 than secondary agents. The user may explicitly specify the occupancy rating for a work type or allow the PC 11 to specify the occupancy rating by merely designating primary agents for some work types. While any value may be used, an occupancy rating

X(i,j) of 70% may be used by the PC 11 as a default value when that agent is designated as a primary agent by the user.

Upon retrieving the occupancy values entered by the user, the PC 11 first verifies that the sum of the occupancy ratings X(i,j) assigned to an agent among the work types is less than, or equal to, the Tocc(i) for that agent. The PC 11 may then take steps to fully populate the initial target matrix.

The PC 11 may first determine the number of effective agents available by summing the Tocc(i) values for the agents schedules to work for any particular time period. For example, if two agents were available and each had a Tocc(i)=50%, then the number of effective agents in this case would be one. The number of effective agents for the system may be determined by solving the equation as follows:

$$effectiveAgents = \sum_{i=1}^{numOfAgents} Tocc(i) .$$

20

A residual staffing level ("residualStaffing") may be determined by subtracting the sum of the predicted workload of each work type ("Prdtworkload(j)") from the number of effective agents as follows:

25

$$residualStaffing = effectiveAgents - \sum_{j=1}^{numOfWorkTypes} Pr dtworkload(j) .$$

If there are more effective agents than the sum of predicted workloads, then extra agents are distributed among the work types based upon loads and staffing priorities. If there are fewer effective agents than the sum of predicted workloads, then each work type is assigned fewer agents than is suggested by its workload.

The number fewer is dependent upon the work loads and priorities ("relativePriority"). In either case, a target number of effective agents for each work type ("TargetFTE(j)") is determined as follows:

5

$$perPortion = \frac{residualStaffing}{\sum_{j=1}^{numOfWorkTypes} (relativePriority(j))(prdtworkload(j))}, \text{ and}$$

$$TargetFTE(j) = (perPortion) (relativePriority(j)) (prdtworkload(j)) + prdtworkload(j).$$

10

To populate the initial target matrix, the PC 11 sequentially selects agents and randomly selects work types. The occupancy $X(i,j)$ given agent i to work type j may also be random or may be a percent of total time or a fixed value, so long as the sum of all occupancies for the agent is less than a user specified $Tocc(i)$ or 100%.

$Tocc(i)$ may be set by the user at anywhere from zero to 100%. If not specified by the user, the $Tocc(i)$ for an agent will have a default value of 100%. If $Tocc(i)$ is set by the user, the PC 11 will not change it. Similarly, if the user selects a work type occupancy $X(i,j)$ for an agent, the PC 11 will not change it.

25

It should be kept in mind that while the PC 11 randomly selects work types, any selected work type will be skipped if an agent is not skilled for that work type (i.e., $ACap(i,j) < 0$). The PC 11 may then randomly select another work type. The PC 11 may also check that the occupancy does not exceed a maximum allows number of work types allowed per agent ("MaxNumWtPerAgent"). If it does, the PC 11 goes on to the next agent.

For instance, where a $Tocc(i)$ for an agent is manually selected by the user at 80% and there are four work types, then the PC 11 may ultimately assign an occupancy of 20% to each work type. If based upon
5 the agent capability $Acap(i,j)$, the agent is not qualified for the first work type, then the PC 11 may assign work type occupancy values of 30% to the second and third work type and 20% to the last work type.

10 In general, the PC 11 will repetitively assign work types $X(i,j)$ until each agents' $Tocc(i)$ is reached. Preferably, the PC 11 uses small values (i.e., fractional occupancies) of $X(i,j)$ to maximize the number of work types (" $numOfAssignedWts(i)$ ").

15 To ensure that each agent gains experience in other work types, a minimum number of work types (" $MinNumWTPerAgent$ ") may also be specified. Where the threshold value for a minimum number of work per agent (" $MinNumWTPerAgent$ ") is not met, the PC 11 may
20 divide up one or more of the agent's occupancies among other work types to achieve the threshold value.

Once an initial target matrix is achieved, the PC 11 may compute a number of assigned equivalent
25 full time agents for each work type (" $assignedFTE(j_0)$ "). The PC 11 also calculates an average agent capability (" $aveCap(j_0)$ ") by averaging the $ACap(i,j_0)$ of the agents given an occupancy for work type j_0 .

30 Once the initial target occupancy matrix is achieved, the PC 11 may begin to interactively repair the matrix. Iterative repair may be performed continuously to accommodate changes in call loading or periodically based upon some objective loading

standard (e.g., queue length for call groups). Where iterative repair is performed periodically, the iterative process may begin and continue for a fixed number of iteration cycles specified by the user.

5 As a first step in the interactive repair process, the PC 11 may compute an objective function value ("computeObjectiveFunctionValue()"). The objective function value provides a means of evaluating a new (iterative) target matrix over a
10 previous target matrix. The value of the objective function may be determined as follows:

$$\text{Value} = (\text{weightFTE}) (\text{scoreFTE}) + (\text{weightSkills}) (\text{scoreSkills}),$$

15 where "weightFTE" is a number indicating how important it is to allocate the right amount of staffing to each work type to match a predicted workload (a default value of weightFTE may be set equal to 1), where "weightSkills" is a number
20 indicating how important it is to maximize the average of aveCap(j) per work type (weighted by the agents' occupancy for that work type) (a default value of weightSkills may be set equal to 10), where

$$25 \quad \text{scoreFTE} = \sum_{j=1}^{\text{numOfWorkTypes}} (\text{targetFTE}(j) - \text{assignedFTE}(j))^2 \quad \text{and}$$

$$\text{scoreSkills} = \sum_{j=1}^{\text{numOfWorkTypes}} (\text{aveCap}(j) - \text{bestCap}(j))^2,$$

where "bestCap(j)" is the highest relative ACap(i,j) score for the work type j.
30

Once the objective function value is determined, agents are again selected sequentially one-by-one.

For each selected agent, a first work type is selected randomly from a list of work types in which the agent already has an occupancy. A second work type is then selected at random and a portion of the agent's occupancy is transferred 104 from the first work type to the second work type.

A revised target matrix is then created using the transferred occupancy. A new objective function value is determined 106 from the revised target matrix. If the new objective function is smaller 108 than the previous objective function, then the change 110 in occupancy is made to the target matrix. If not, then the next agent is selected and the process is repeated.

In addition, before the change in occupancy is executed, the PC 11 performs the checks discussed above. For example, is the agent qualified to perform the work of the second work type?

In an alternative embodiment, the iterative repair may include selection of an overstaffed work type for which the agent has a non-zero occupancy value and selection of a second work type for which the agent is qualified. If the objective function is smaller, the change is implemented. Otherwise, the next agent is selected and the process is repeated.

The number of agents required for each work type (i.e., $\text{targetFTE}(j)$) for each work type j may be estimated from historical workload and Erlang tables, or from force management packages. For example, a prior history of call loading for a particular work type may be retrieved from an archive. The loading may be increased by some factor based upon most recent history to achieve an initial estimation of the number of agents required for each call type.

Iterative repair may be made periodically or only when required by call loading for a group. Specifically, an increase in a call arrival rate of a particular call type over the initial (or later) loading estimate may be used to trigger iterative repair.

The need for iterative repair may be determined by a number of methods. For example, the length of time a caller spends in a call queue is one measure of call loading. However, since callers would be expected to become discouraged and hang-up after a short time period, it is not the only measure available.

One other simple measure of call loading may be based upon the number of calls directed to the call type per time period. Using well known Erlang calculation techniques and an average time per call, this can be converted into a required number of full time agents.

A specific embodiment of a method and apparatus for an improved skill-based call routing system according to the present invention has been described for the purpose of illustrating the manner in which the invention is made and used. It should be understood that the implementation of other variations and modifications of the invention and its various aspects will be apparent to one skilled in the art, and that the invention is not limited by the specific embodiments described. Therefore, it is contemplated to cover the present invention any and all modifications, variations, or equivalents that fall within the true spirit and scope of the basic underlying principles disclosed and claimed herein.

THE EMBODIMENTS OF THE INVENTION FOR WHICH AN EXCLUSIVE PROPERTY OR PRIVILEGE IS CLAIMED ARE DEFINED AS FOLLOWS:

1. A method of assigning agents of an automatic call distributor to incoming calls of a plurality of call types handled by the automatic call distributor, such method comprising the steps of:

determining a target occupancy matrix including a target occupancy for each agent of the agents of the automatic call distributor for each call type of the plurality of call types and where the total occupancies among at least some of the agents are not equal;

in an overstaffed situation, processing a call of a first type of the types determined in the target occupancy matrix; and

assigning the processed call to an agent of the agents of the automatic call distributor with a largest relative difference between an actual occupancy of calls of the first type handled by the agent and the target occupancy of calls of the first type determined for the agent in the target occupancy matrix; and

in an understaffed situation, when an agent of the agents becomes available, selecting a call from a queue of a work type of the plurality of work types having a largest relative difference between actual occupancy and target occupancy among the work types of the available agent; and

assigning the selected call to the available agent.

2. The method of assigning agents as in claim 1 further comprising generating the target matrix from permanent, semi-permanent and variable data.
3. The method of assigning agents as in claim 2 wherein the step of generating the target matrix from the permanent data further comprises defining a plurality of work types where each work type characterizes at least some of the incoming call types.
4. The method of assigning agents as in claim 3 wherein the step of generating the target matrix from the permanent data further comprises providing a list of agent skill types required for each work type of the incoming call types.
5. The method of assigning agents as in claim 4 wherein the step of generating the target matrix from the permanent data further comprises providing a minimum agent skill level required by each work type of the incoming call types.
6. The method of assigning agents as in claim 5 wherein the step of generating the target matrix from the semi-permanent data further comprises providing a skill level of each agent with respect to each skill type required by each work type of the incoming call types.
7. The method of assigning agents as in claim 6 wherein the variable data further comprises manually providing a

target occupancy level for at least some agents of the target matrix.

8. The method of assigning agents as in claim 2 wherein the step of generating the target matrix further comprises randomly assigning work type occupancies to each agent of the plurality of agents within the target matrix.

9. The method of assigning agents as in claim 8 wherein the step of randomly assigning work type occupancies to each agent of the plurality of agents within the target matrix further comprises iteratively repairing the target matrix.

10. The method of assigning agents as in claim 9 wherein the step of iteratively repairing the target matrix further comprises sequentially selecting an agent and randomly selecting a work type.

11. The method of assigning agents as in claim 10 wherein the step of sequentially selecting an agent and randomly selecting a work type further comprises assigning a fractional occupancy of the agent to the randomly selected work type, thereby generating a new target matrix.

12. The method of assigning agents as in claim 11 wherein the step of sequentially selecting an agent and randomly selecting a work type further comprises calculating a change in an objective function of the new target matrix.

13. The method of assigning agents as in claim 12 wherein the step of calculating a change in an objective function of the new target matrix further comprises adopting the new target matrix as the repaired matrix when the calculated change is less than zero.

14. An apparatus for assigning agents of an automatic call distributor to incoming calls of a plurality of call types handled by the automatic call distributor, such apparatus comprising:

means for determining a target occupancy matrix including a target occupancy for each agent of the agents of the automatic call distributor for each call type of the plurality of call types and where total occupancies among at least some of the agents are not equal;

means in an overstaffed situation for processing a call of a first type of the types determined in the target occupancy matrix; and

means for assigning the processed call to an agent of the agents of the automatic call distributor with a largest relative difference between an actual occupancy of calls of the first type handled by the agent and the target occupancy of calls of the first type determined for the agent in the target occupancy matrix;

means in an understaffed situation, when an agent of the agents becomes available, for selecting a call from a queue of a work type of the plurality of work types an agent having a largest relative difference between actual occupancy and target occupancy among the work types of the available agent; and

means for assigning the selected call to the available agent.

15. The apparatus for assigning agents as in claim 14 further comprising means for generating the target matrix from a plurality of permanent, semi-permanent and variable data.

16. The apparatus for assigning agents as in claim 15 wherein the means for generating the target matrix from the permanent data further comprises means for defining a plurality of work types where each work type characterizes at least some of the incoming call types.

17. The apparatus for assigning agents as in claim 16 wherein the means for generating further comprises means for providing a list of agent skill types required for each work type of the incoming call types.

18. The apparatus for assigning agents as in claim 17 wherein the means for generating further comprises means for providing a minimum agent skill level required by each work type of the incoming call types.

19. The apparatus for assigning agents as claim 18 wherein the means for generating further comprises means for providing a skill level of each agent with respect to each skill type required by each work type of the incoming call types.

20. The apparatus for assigning agents as in claim 19 wherein the means for generating further comprises means for manually providing a target occupancy level for at least some agents of the target matrix.

21. The apparatus for assigning agents as in claim 15 wherein the means for generating the target matrix further comprises means for randomly assigning work type occupancies to each agent of the plurality of agents within the target matrix.

22. The apparatus for assigning agents as in claim 21 wherein the means for randomly assigning work type occupancies to each agent of the plurality of agents within the target matrix further comprises means for iteratively repairing the target matrix.

23. The apparatus for assigning agents as in claim 22 wherein the means for iteratively repairing the target matrix further comprises means for sequentially selecting an agent and randomly selecting a work type.

24. The apparatus for assigning agents as in claim 23 wherein the means for sequentially selecting an agent and randomly selecting a work type further comprises means for assigning a fractional occupancy of the agent to the randomly selected work type, thereby generating a new target matrix.

25. The apparatus for assigning agents as claim 24 wherein the means for sequentially selecting an agent and

randomly selecting a work type further comprises means for calculating a change in an objective function of the new target matrix.

26. The apparatus for assigning agents as in claim 25 wherein the means for calculating a change in an objective function of the new target matrix further comprises means for adopting the new target matrix as the repaired matrix when the calculated change is less than zero.

27. An apparatus for assigning agents of an automatic call distributor to incoming calls of a plurality of call types handled by the automatic call distributor, such apparatus comprising:

a matrix processor adapted to determine a target occupancy matrix including a target occupancy for each agent of the agents of the automatic call distributor for each call type of the plurality of call types and where total occupancies among at some of the agents are not equal;

a call processor adapted to process a call of a first type of the types determined in the target occupancy matrix; and

a call distributor adapted to assign the call in an overstaffed situation to an agent of the agents of automatic call distributor with a largest relative difference between an actual occupancy of calls of first type handled by the agent and the target occupancy of calls of the first type determined for the agent in the target occupancy matrix,

the call distributor, in an understaffed situation

when an agent of the agents becomes available, being further adapted to select and assign a call to the available agent from a queue of a work type of the plurality of work types having a largest relative difference between actual occupancy and target occupancy among the work types of the available agent.

28. The apparatus for assigning agents as in claim 27 further comprising a plurality of permanent, semi-permanent and variable data.

29. The apparatus for assigning agents as in claim 28 wherein the permanent data further comprises a plurality of work types where each work type characterizes at least some of the incoming call types.

30. The apparatus for assigning agents as in claim 29 wherein the matrix processor further comprises a list of agent skill types required for each work type of the incoming call types.

31. The apparatus for assigning agents as in claim 30 wherein the matrix processor further comprises a minimum agent skill level required by each work type of the incoming call types.

32. The apparatus for assigning agents as in claim 31 wherein the matrix processor further comprises a skill level of each agent with respect to each skill type required by each work type of the incoming call types.

33. The apparatus for assigning agents as in claim 32 wherein the matrix processor further comprises a manually entered target occupancy level for at least some agents of the target matrix.

34. The apparatus for assigning agents as in claim 33 wherein the matrix processor further comprises a selection processor adapted to randomly assign work type occupancies to each agent of the plurality of agents within the target matrix.

35. The apparatus for assigning agents as in claim 34 wherein the selection processor further comprises a repair processor adapted to iteratively repair the target matrix.

36. The apparatus for assigning agents as in claim 35 wherein the repair processor further comprises an objective function processor adapted to calculate a change in an objective function of the new target matrix.

37. The apparatus for assigning agents as in claim 36 wherein the objective function processor further comprises an update processor adapted to adopt the new target matrix as the repaired matrix when the calculated change is less than zero.

FIG. 1

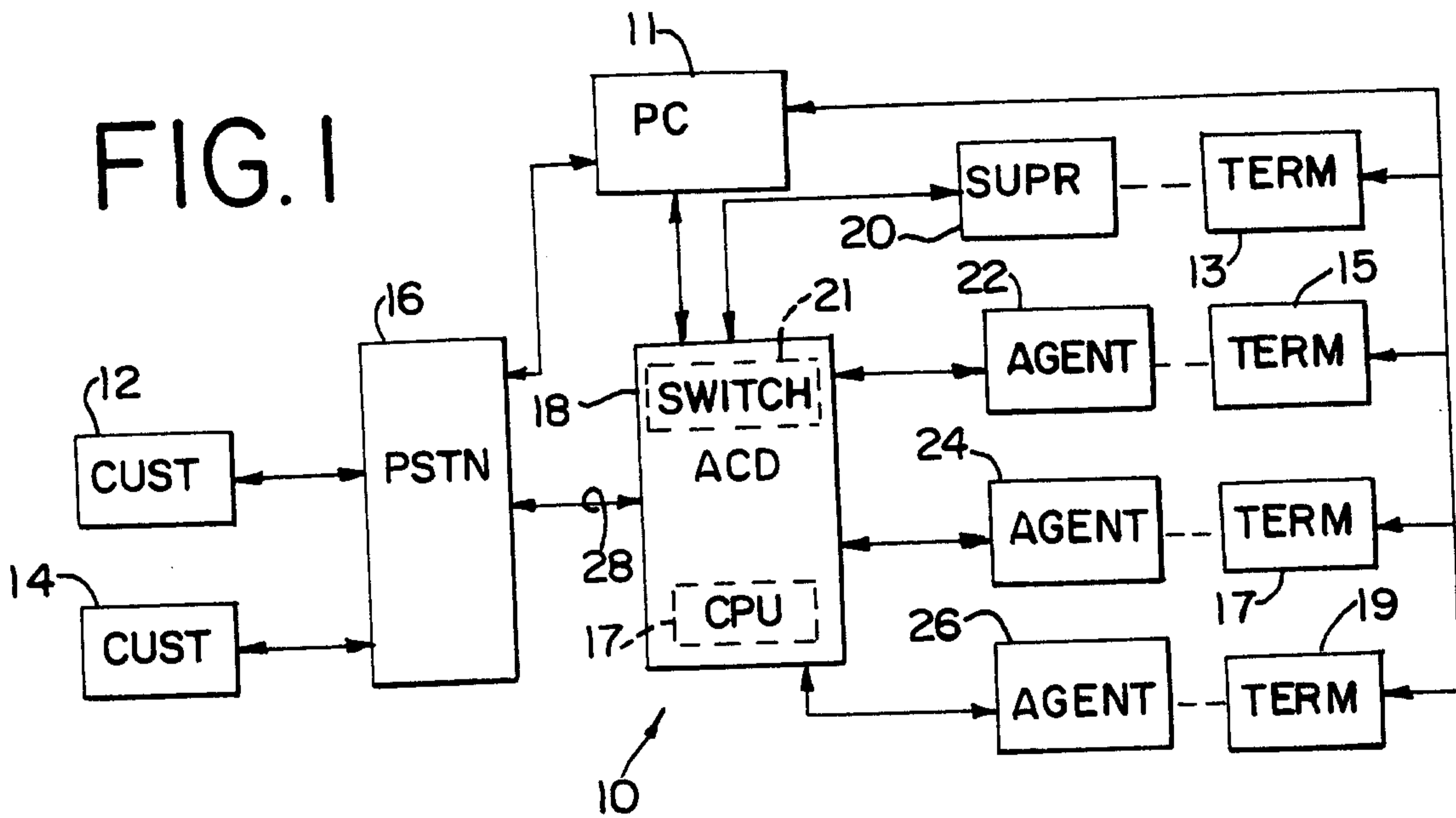

FIG. 2

