

No. 632,537.

Patented Sept. 5, 1899.

C. F. RIGBY.
WELL DRILLING MACHINERY.

(Application filed Dec. 8, 1898.)

(No Model.)

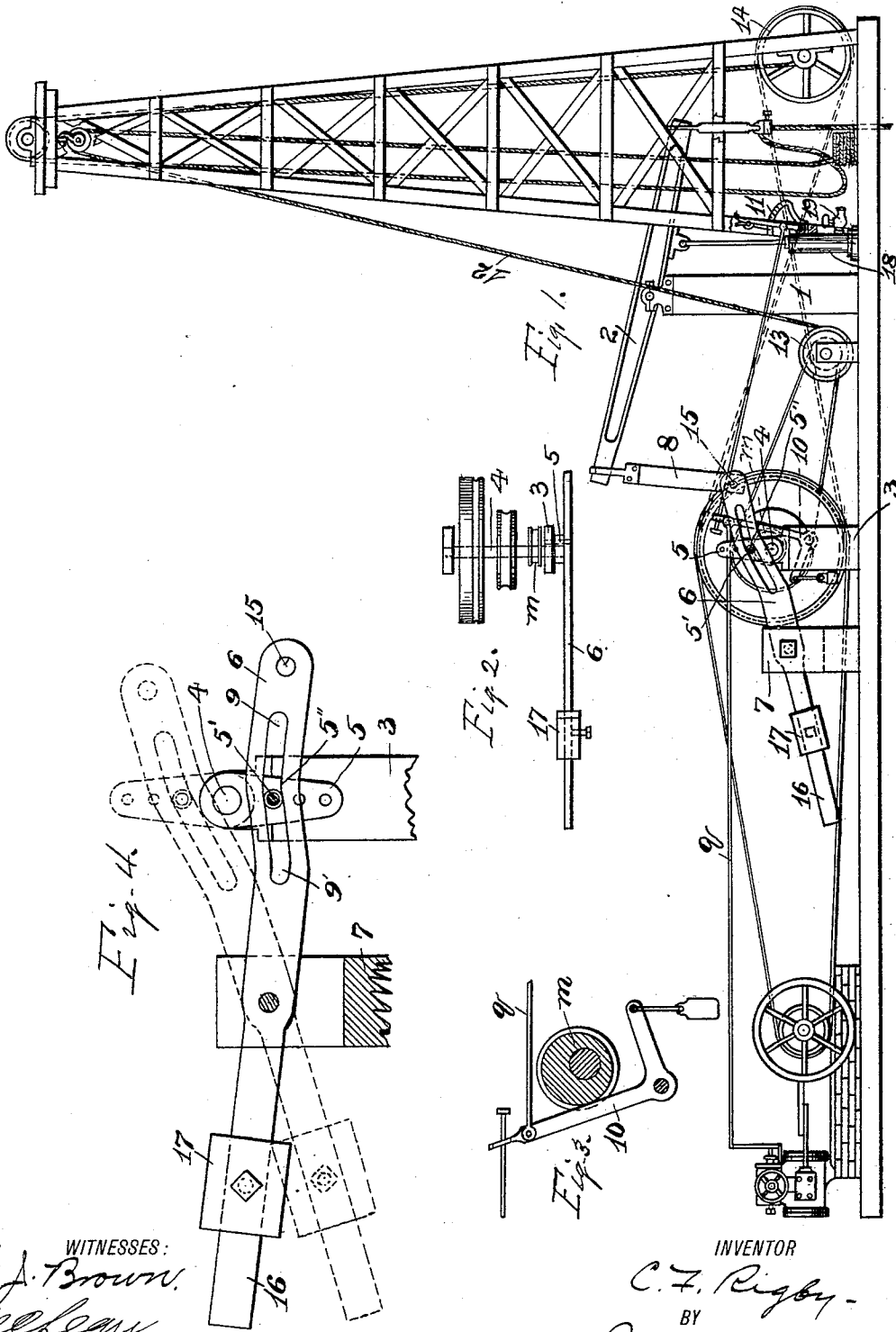

WITNESSES:
W. J. Brown.
W. J. Brown.

INVENTOR
C. F. Rigby.
BY
J. M. Nesbit.
ATTORNEY.

UNITED STATES PATENT OFFICE.

CLARK F. RIGBY, OF MANNINGTON, WEST VIRGINIA.

WELL-DRILLING MACHINERY.

SPECIFICATION forming part of Letters Patent No. 632,537, dated September 5, 1899.

Application filed December 8, 1898. Serial No. 698,606. (No model.)

To all whom it may concern:

Be it known that I, CLARK F. RIGBY, a citizen of the United States, residing at Mannington, in the county of Marion and State of West Virginia, have invented new and useful Improvements in Well-Drilling Machinery, of which the following is a specification.

With well-drilling machinery now in general use the walking-beam and crank-shaft are directly connected by a pitman, so that the up and down strokes of the beam have the same speed. This motion is open to several objections, principal among them being wear on and stretching of the drilling-cable, caused by sudden lifting or jerking of the tools from the hole-bottom. This difficulty is in a measure obviated by the mechanism shown in my Patent No. 532,338, dated January 8, 1895, which automatically shuts off steam from the engine at the beginning of every downstroke of the beam and opens the engine-throttle at the commencement of the upstroke. The engine is thus prevented from running at an accelerated speed when relieved of its load and imparts to the cable and tools a more steady and gradual lift than though they were started by the motor when running at increased speed. That improvement, however, does not enable me to increase the downstroke of the beam and tools without correspondingly increasing the upstroke, and hence it becomes the primary object of the present invention to provide mechanism whereby the downstroke may be accelerated and the upstroke made slower, the latter consisting more of a gradual pull without sudden stretching and jerking, to which the cable has heretofore been subjected. The motion thus acquired enables me not only to preserve the cable, but also to gain the advantage of the full beam-stroke, which prior to my invention has been partially lost owing to stretching of the great length of cable. In other words, I reverse the movement of the drilling-cable as now operated by increasing its downstroke and decreasing its upstroke.

I have embodied my invention in the mechanism hereinafter described and claimed and illustrated by the accompanying drawings, in which—

Figure 1 is an elevation of a drilling outfit

provided with my improvement. Fig. 2 is a detail view of the crank-shaft. Fig. 3 is a sectional view of the same. Fig. 4 is a detail view of the beam vibratory lever, its lowermost position being shown by full lines and its uppermost position by dotted lines.

Referring to the drawings, 1 is the samson-post; 2, the walking-beam; 3, the jack-post; 4, the band-wheel shaft, and 5 the crank.

6 is a lever which crosses the vertical plane of shaft 4, the same being fulcrumed on one side of the shaft on post 7, while its free end at the opposite side of the shaft is detachably connected to walking-beam pitman 8.

Opposite shaft 4 the lever is formed with an elongated slot, and crank-pin 5', operating therein, traverses slot portion 9 when depressing the lever, and as the direction of this slot portion is substantially transverse the path of downward travel of the pin, also as the pin is working at a maximum distance from the fulcrum, the movement is slow and unattended by jerks. A little before the crank-pin reaches the bottom divergence of slot portions 9 and 9' it has completed the depression of the lever, and until the pin moves over said diverging point and into slot portion 9' there is a pause in the lever's movement sufficiently pronounced to bring the cable to a noticeable standstill, thus relieving it of the torsional strain incident to a sudden reversal of movement. Then as slot portion 9' is to an extent in the path of travel of the crank-pin's upward movement and as the latter is operating nearer the lever-fulcrum the rise of the lever is much quicker than its depression, so that the drill is dropped suddenly, and as precautions have been taken against stretching and torsionally straining the cable there is no lost motion, and the beam is afforded the benefit of the full beam-stroke. This arrangement not only increases the drill's capacity, but also preserves the cable. As the slot constitutes a closed way for the crank-pin, the latter and lever are never disengaged, and the lever is under constant control of its actuating means.

I have here shown the mechanism covered by my Patent No. 532,338, as it is designed for use in conjunction with the present improvement. The only changes therein which I will here note are the substitution of weighted

bell-crank lever 10 for spring-actuated arm I of the patent for automatically opening the throttle through the medium of eccentric M and rod Q. Also in place of weighted line O of the patent I prefer the ratchet-and-lever mechanism 11 for holding lever 10 from contact with cam M with the throttle continuously open, as when baling, through the medium of sand-line 12 and reel 13, also when operating bull-wheel 14 for casing or for withdrawing the tools. At such times the pitman and lever are disconnected at 15; but as the lever remains coupled to the crank and vibrates therewith I provide it with tailpiece 16, carrying poise 17, which act as a counterweight to prevent shaking and wear of the machinery.

A dash-pot 18 is connected to the forward end of the beam for checking, when necessary, its downstroke, the resistance of the dash-pot being regulated by petcock 19.

Having thus fully described my invention, what I claim as new, and desire to secure by Letters Patent, is--

1. In well-drilling machinery, the combination of a crank-shaft carrying a crank-pin, a cable-actuating lever fulcrumed to reciprocate vertically, the lever having an elongated slot in which the crank-pin operates, the outer portion of the slot being disposed substantially transverse the path of the pin's travel when depressing the lever, whereby the latter is given gradual downward movement, and the slot portion 9', or that part nearest

the lever-fulcrum, disposed at an angle to slot portion 9 so as to more nearly coincide with the path traveled by the crank in its ascent, thereby causing the lever to rise at accelerated speed, substantially as shown and described.

2. In well-drilling machinery, the combination of a crank-shaft carrying a crank-pin, a cable-actuating lever fulcrumed to reciprocate vertically, the lever having an elongated slot in which the crank-pin operates, the outer portion 9 of the slot extending substantially transverse the path of downward travel of the pin, whereby the descent of the lever is slow and steady, the inner portion 9' diverging from portion 9 of the slot so as to more nearly coincide with the path of upward travel of the pin, thereby assisting the lever to rise at accelerated speed, the parts being so constructed and arranged that the point of divergence of the slot portions is reached by the crank-pin after the lever finishes its downward reciprocation and before it begins to ascend, whereby the lever and cable have a perceptible rest and torsional strain of the latter incident to sudden reversal of movement is avoided, substantially as shown and described.

In testimony whereof I have hereunto set my hand in presence of two subscribing witnesses.

CLARK F. RIGBY.

Witnesses:

M. L. BENEDUM,
A. A. J. GASKILL.