

Oct. 22, 1940.

G. SCHNADEL

2,219,082

HULL CONSTRUCTION FOR SHIPS

Filed Nov. 18, 1936

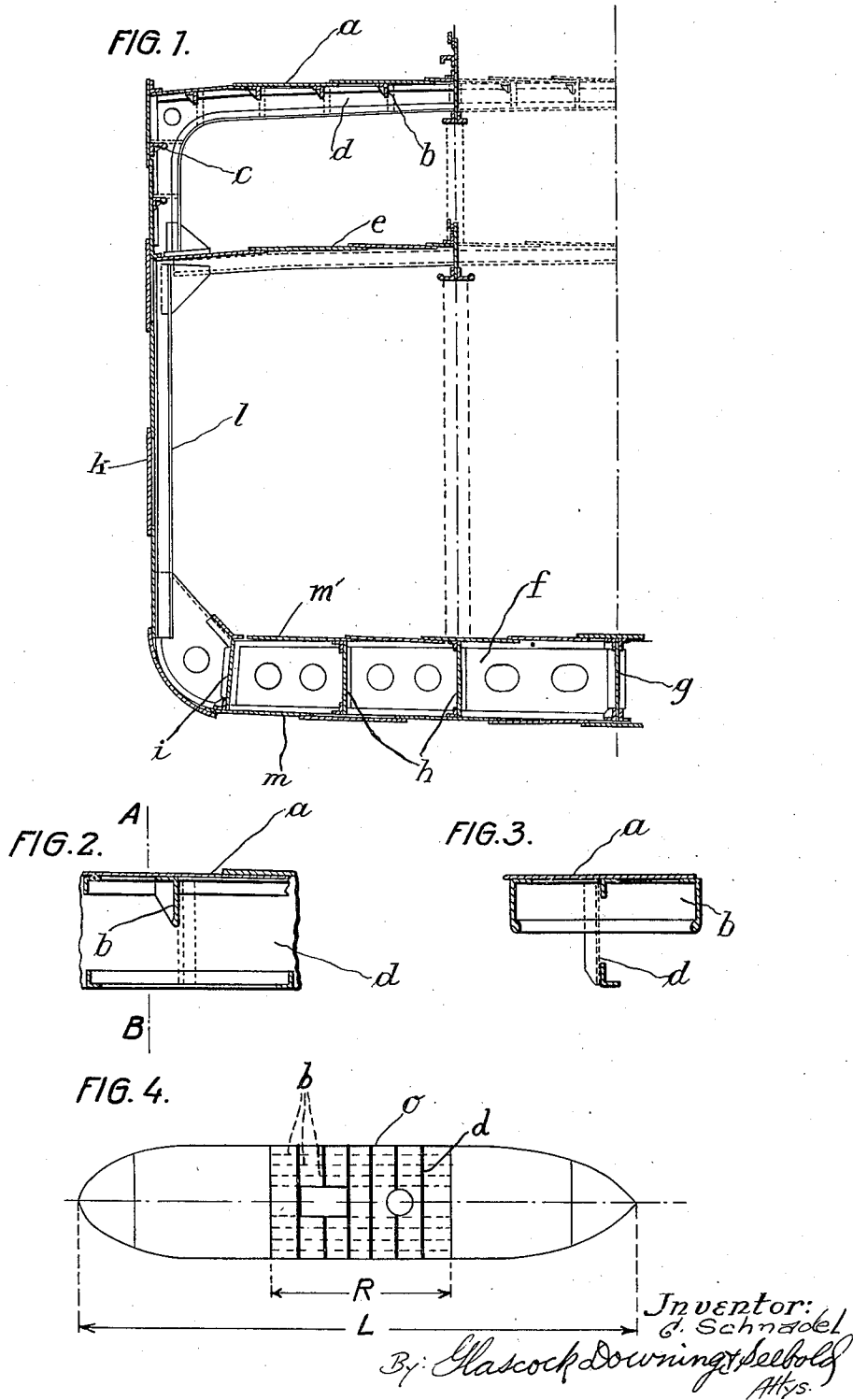

Inventor:
G. Schnadel
By: *Glascok Downing & Selholz*
Attys.

UNITED STATES PATENT OFFICE

2,219,082

HULL CONSTRUCTION FOR SHIPS

Georg Schnadel, Berlin-Charlottenburg,
Germany

Application November 18, 1936, Serial No. 111,545
In Germany November 19, 1935

4 Claims. (Cl. 114—79)

The hull of a ship is a highly-stressed box-girder, which is subjected to positive and negative moments in a sea-way, when the vessel lies in a wave-hollow or on a wave-crest. It has previously been assumed that the positive and negative moments caused by the sea-way are practically equal, and these moments have been calculated under the assumption that the wave-height is $\frac{1}{20}$ of the ship length for both wave-hollow and wave-crest. In accordance with this assumed loading, substantial compressive forces are calculated to exist in the deck, and, especially in the bottom. To carry these compressive stresses longitudinal framing was introduced in place of the transverse framing system. The greatest emphasis was laid on stiffening the bottom against compressive loads, which was accomplished by arranging the transverse beams or frames with large spacing and the longitudinal frames with closer spacing.

The construction with longitudinal frames in the bottom has very serious disadvantages. The longitudinal frames are very heavy, since they are simultaneously subjected to water pressure and longitudinal stresses. Leading them through the bulkheads is attended with serious difficulties. In order to avoid leakage through the bulkheads, the longitudinal frames are made intercostal at the bulkheads. This leads to a new difficulty, since at the ends of these longitudinal frames excessively high stresses appear. In addition, cargo space is lost on account of the heavy and deep transverse frames. The previous types of longitudinally-framed construction are therefore expensive.

Investigations on board a ship have shown that the assumptions, on which the construction of ships has previously been based, are not correct. By means of very careful measurements it has been determined that the positive moments resulting from the waves, which cause compressive stresses in the deck, are much greater than the negative moments, which cause compressive stresses in the bottom. Consequently, for many types of ship it is fundamentally incorrect to stiffen the bottom, which is essentially very strong, with longitudinal members.

In accordance with the invention, an improvement in the construction of ships is claimed, whereby in the upper flange of the ship girder, formed by the upper decks, longitudinal beams in conjunction with widely-spaced transverse frames are to be utilized, while in the bottom no longitudinal frames are fitted; instead the bottom is designed in conventional fashion with

transverse framing at the usual spacing, and widely-spaced longitudinal members, such as the vertical keel, side longitudinals and plate girders. This construction is without the disadvantages of the usual design. The upper flange, whose stresses under compression are determinative, is adequately stiffened.

The deck, which forms the upper flange (strength deck), is in many ships above the bulkhead deck. The longitudinal beams need not in these cases be led through the bulkheads. In the lower flange, where tension is the significant stress, there are no difficulties resulting from intercostal longitudinals or leakage through the bulkheads to be feared. The loading of the bottom plating is favorable, since the longitudinal stresses are uniformly distributed over the breadth, and no discontinuities occur because of intercostal longitudinals.

It has been impossible to effectively carry the tensile and compressive forces in the longitudinals in the bottom, which are large because of their large area, through the bulkheads. This difficulty does not occur in longitudinal deck-beams, which are relatively light and which are not heavily loaded. There is therefore less difficulty in arranging the construction so as to permit cutting the longitudinals without loss of continuity.

The invention proposes therefore a new combination of the longitudinal system of the strength deck and the topsides with the usual transverse system of framing in the bottom and sides of the ship.

The invention is shown in the accompanying drawing in the form of examples.

Fig. 1 shows schematically a ship cross-section.

Fig. 2 a part of the stiffened strength deck to large scale.

Fig. 3 a section of the strength deck along the longitudinal beams in accordance with the line A—B.

Fig. 4 a view of a ship with a further development of this hull construction to small scale.

At the ends of the ship the deck has the usual transverse deck beams narrowly spaced with deck girders as shown in Figs. 1 to 3 of the disclosure. The other parts of the ship's hull are provided with the usual transverse side framing and the transverse floors in the bottom as described in the foregoing part.

If the strength deck forms a part of an isolated superstructure in the middle part of the ship such as a bridge deck, the longitudinal sys-

tem of the deck beams is only employed in the superstructure. All other parts (as the other decks, the sides, the bottom and the erections at the end of the ship) are to be built in the transverse system of the ship construction.

The upper-deck *a* forms the actual strength-deck and is, in accordance with the invention stiffened with the longitudinal stringer members *b*. Similarly the upper flange formed by the side is stiffened by the longitudinal stringer members *c*.

The longitudinal stringer members *b* and *c* are carried by the transverse web-beams *d*, separated by several frame-spaces, through which they are led.

The bulkhead deck is here the deck *e*; that is, the bulkheads extend only to this deck. In accordance with the invention no longitudinals are provided in the bottom. Instead there are in the bottom the usual transverse frame members *f*, which may be either solid or lightened, arranged with the usual spacing, while longitudinal members such as the vertical keel *g*, plate girders *h* and margin plate *i* with the usual spacing are provided.

In the drawing *k* indicates the side plating, *l* the usual transverse frame members extending between the deck *e* and the bottom and *m* and *m'* indicate the outer and inner bottoms.

Further improvement is also possible, when the fact is considered, that the ends of the ships need withstand only small bending moments. Therefore the installation of longitudinal stringer members *b* can be restricted to only the middle part of the ship's length, for example to the superstructure erections. Consequently the construction is made still more economical, since these longitudinal beams have only little curvature at the central portion of the hull.

This is indicated in Fig. 4, where these members *b* are shown extending only over the middle part of the ship's length *L*, that is to say only over the length *R* of the superstructure.

What I claim is:

1. In a ship, the combination with a hull construction having a bottom, sides, a deck and

transverse framing including equally spaced transverse frame members attached at their upper ends to said deck thence extending downwardly along the sides and bottom of the hull, said frame members being free of all longitudinal support except the usual keel and plate girders for the bottom; of a relatively stiff upper structure including a second deck positioned above said first deck, sides between the decks, equally spaced longitudinal stringer members engaging and supporting said upper deck and the sides between the decks and equally spaced transverse side and deck web beams directly supporting said stringer members, the distance between said web beams being a plurality of times that of the spacing of the transverse frame members.

2. In a ship construction as claimed in claim 1 wherein said relatively stiff upper structure extends along the central portion of the hull only.

3. In a ship construction as claimed in claim 1 wherein said relatively stiff upper structure extends along the central portion of the hull only and equally spaced deck beams engaging said frame members and forming the sole support of said first mentioned deck.

4. In a ship, the combination with a hull construction having inner and outer bottoms, sides, a deck and transverse framing including equally spaced transverse frame members attached at their upper ends to said deck thence extending downwardly along the sides and between the bottoms of the hull, said frame members being free of all longitudinal support except the usual keel and plate girders between the bottoms; of a relatively stiff upper structure including a second deck positioned above said first deck, sides between the decks, equally spaced longitudinal stringer members engaging and supporting said upper deck and the sides between the decks and equally spaced transverse side and deck web beams directly supporting said stringer members, the distance between said web beams being a plurality of times that of the spacing of the transverse frame members.

GEORG SCHNADEL.