

P. BROWN.

WISE.

No. 399,014.

Patented Mar. 5, 1889.

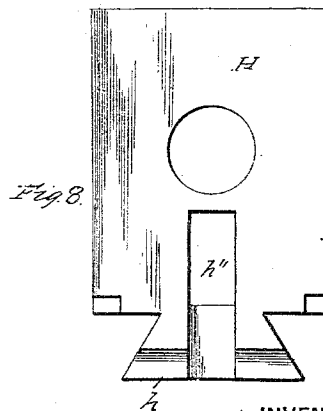
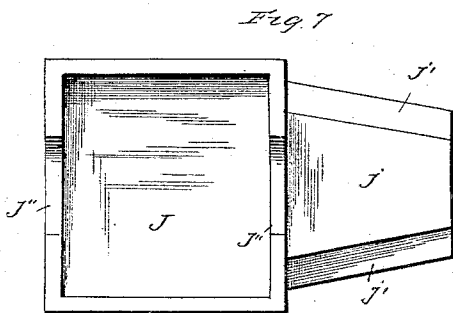
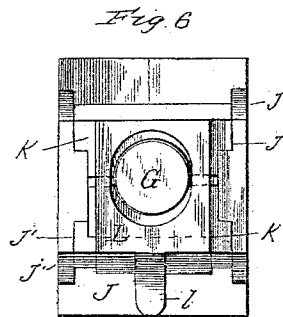
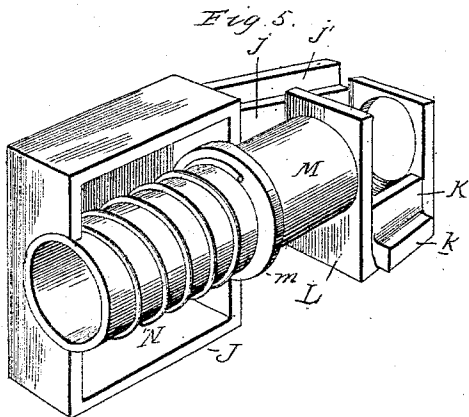
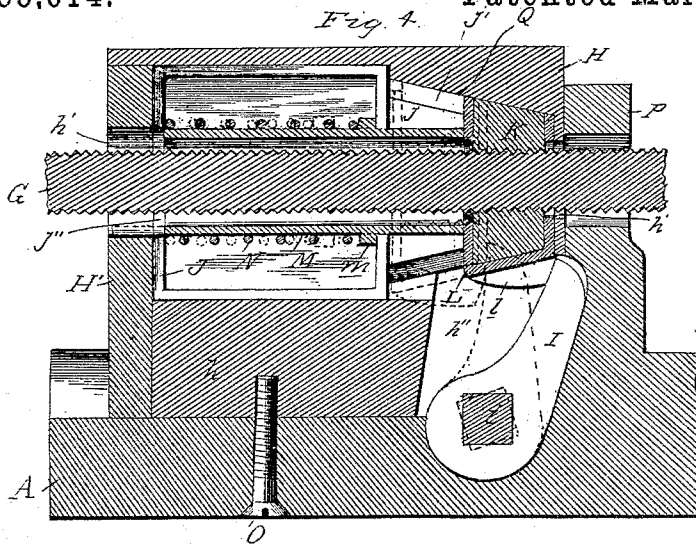

WITNESSES:

C. J. Anderson
J. E. Robertson

INVENTOR.

Perry Brown
 BY *J. M. Robertson*
 ATTORNEY.

UNITED STATES PATENT OFFICE.

PERRY BROWN, OF LOUISVILLE, KENTUCKY, ASSIGNOR TO DANIEL E. DOHERTY, OF SAME PLACE.

WISE.

SPECIFICATION forming part of Letters Patent No. 399,014, dated March 5, 1889.

Application filed June 12, 1888. Serial No. 276,785. (No model.)

To all whom it may concern.

Be it known that I, PERRY BROWN, a citizen of the United States, residing at Louisville, in the county of Jefferson and State of Kentucky, have invented certain new and useful Improvements in Vises, of which the following is a specification, reference being had therein to the accompanying drawings.

This improvement relates to that class of vises in which a divided nut is employed in order that the nut may be opened to allow of the screw being rapidly moved through it when desired; and the invention consists in the peculiar construction, arrangement, and combination of parts, hereinafter more particularly described, and then definitely pointed out in the claims.

In the accompanying drawings, Figure 1 shows a side view of my vise; Fig. 2, a plan of the same, partly broken away; Fig. 3, a longitudinal vertical section of the same. Figs. 4, 5, 6, 7, and 8 are details on a larger scale, Fig. 4 being a vertical central section, Fig. 5 a perspective of part of a box, tube-spring, yoke, &c., Fig. 6 an end view of the parts shown in Fig. 5, Fig. 7 a side elevation of the opposite half of the box shown in Fig. 5, and Fig. 8 an end view of the box shown in Fig. 4.

Referring now to the details of the drawings, A represents the fixed or box part of the device, which is provided with a corrugated base, *a*, fitting onto a corrugated plate, B, which is intended to be screwed to a bench, and the whole secured together by a threaded pin, C, and hand-nut *c*, as shown.

The upper part of the part A is provided with a stud having an inclined or conical base, *a'*, and ball *a''*. Surrounding this conical base is a washer, D, whose top is curved, and in which sets the bottom of the jaw E, which is made in two parts, *e* and *e'*, embracing the ball *a''*, and screwed or fastened together in any convenient manner, the whole being so arranged as to be readily set in any desired position, and may be turned so as to bring the round part of the jaw inward to hold objects having a concave or curved face.

The movable jaw F is of substantially the usual form and carries the usual screw, G;

but the method of fastening these two together is different from that usually employed. At *f* is a guide through which the smooth part or shank of the screw passes, and at *g* is a collar, which is fastened there by any convenient device, but preferably by screws *g'*, which device makes a very convenient and solid fastening for the screw, and the guide *f* serves to steady and strengthen the screw. In the bed of the fixed part A of the vise is a dovetail-shaped recess, in which is set a dovetail projection, *h*, on a box, H, having openings *h' h'* at each end for the passage of the screw, and a slot, *h''*, through which works a finger, I, on a rock-shaft, *i*, which is operated by a thumb-lever, *i'*. This box I usually make with a removable end piece, H', which is necessary to allow of the insertion of a second box, J, having arms *j*, with inclined guides *j'*, on which work a divided nut, K, by means of its flange *k*, and which is embraced by a yoke, L, which latter has a downwardly-projecting lug, *l*, against which the finger I bears.

Inside the box J, and working through holes *j''* in each end of the same, is a tube, M, provided with a flange, *m*, against which works a spring, N, whose opposite point of resistance is one end of the box J. This spring is so arranged as to always tend to drive the tube M toward the yoke L, and thus push it and the divided nut K toward and against the finger I.

The box H is secured in position by a screw, O, passing through the bottom of the fixed part of the vise; but any other convenient mode of fastening may be adopted.

At Q is shown a pair of inclines, which are of such shape as to hold the nut and prevent its opening, except as they travel along the guides *j'*, whereby it is rendered impossible for the screw to force the sections of the nut apart.

I show at P a perforated stud, against which the end of the box H is set; but this is not absolutely necessary to the perfect operation of the vise.

The operation is as follows: Supposing the vise to be closed and it is desired to hold a large article in the same, now by pushing the thumb-lever *i'* the finger I comes in contact

with the yoke L and pushes said yoke and the nut toward the boxes H J, and thus forces the halves of the nut along the inclined guides and separating the said halves of the nut, the yoke L moving downward as it moves along.

5 The screw, being no longer held by the nut, can be readily drawn out, and thus the jaws may be rapidly separated without the slow process of turning the screw, as in common
10 vises. The articles to be held may then be placed between the jaws of the vise, and by pressing on the thumb-lever *v'* the nut is opened and the movable part of the vise pushed inward until the jaws touch the arti-
15 cle, when a slight turn of the screw will firmly hold the jaws in position and the article will be securely held in the vise.

By this it will be seen that I have invented a vise that is very convenient in use, as it can
20 be rapidly operated and will hold articles of various shapes that cannot be held in vises such as are commonly used.

What I claim as new is—

1. In a vise, and in combination with the
25 screw thereof, a divided nut constructed, as described, so as to move in the direction of the length of the screw as the nut opens, substantially as described.

2. In a vise, and in combination with the
30 screw thereof, a divided nut and means, as the thumb-lever *v'*, rocking shaft *i*, finger I, and the inclined guides *j'*, for opening said nut, substantially as described.

3. In a vise, and in combination with the
35 screw thereof, the box J, having guides *j'*, a tube working in the box, a spring operating

on said tube, a divided nut working on said guides, a yoke embracing said nut, and vibrating finger operating said nut, substantially as described.

4. In a vise, and in combination with the
40 screw and the movable and fixed sections of the vise, a box, H, secured in said fixed section, a second box inclosed in said box H and having guides *j'*, a divided nut whose sections
45 travel on said guides, a yoke embracing said nut-sections, a tube acting on said yoke and a vibrating finger operating on said yoke in
50 opposition to the spring and tube, substantially as described.

5. The combination, with one of the sections of a vise having a ball-stud, of a movable jaw with a ball-socket formed therein and having
55 its bottom curved, and a washer surrounding said ball-stud and provided with a curved face, substantially as described.

6. In a vise, and in combination with the screw thereof, a divided nut constructed, as
60 described, so as to move on inclined guides set between the ends of the sections of the nut and a pair of inclines above and below the nut to hold them firmly against the action
65 of the screw, substantially as described.

In testimony whereof I affix my signature,
in presence of two witnesses, this 11th day of
June, 1888.

PERRY BROWN.

Witnesses:

W. T. ROBERTSON,
JOHN T. ARMS.