

(19)



Europäisches Patentamt
European Patent Office
Office européen des brevets



(11)

EP 1 225 959 B1

(12)

EUROPEAN PATENT SPECIFICATION

(45) Date of publication and mention
of the grant of the patent:
05.07.2006 Bulletin 2006/27

(21) Application number: **00971542.6**

(22) Date of filing: **20.10.2000**

(51) Int Cl.:
A63B 69/18 (2006.01) A63B 22/02 (2006.01)

(86) International application number:
PCT/GB2000/004063

(87) International publication number:
WO 2001/030464 (03.05.2001 Gazette 2001/18)

(54) **APPARATUS FOR SIMULATING A SKI SLOPE**

SIMULATIONSSKIPISTE

DISPOSITIF DE SIMULATION D'UNE PENTE DE SKI

(84) Designated Contracting States:
**AT BE CH CY DE DK ES FI FR GB GR IE IT LI LU
MC NL PT SE**

(30) Priority: **22.10.1999 GB 9925132
31.08.2000 GB 0021454**

(43) Date of publication of application:
31.07.2002 Bulletin 2002/31

(73) Proprietor: **Showan, Jonathan Mark Burling
Barham,
Canterbury,
Kent, CT4 6HJ (GB)**

(72) Inventor: **Showan, Jonathan Mark Burling
Barham,
Canterbury,
Kent, CT4 6HJ (GB)**

(74) Representative: **Ertl, Nicholas Justin
Elkington and Fife LLP,
Prospect House,
8 Pembroke Road
Sevenoaks,
Kent TN13 1XR (GB)**

(56) References cited:
US-A- 4 344 616 US-A- 5 162 029

EP 1 225 959 B1

Note: Within nine months from the publication of the mention of the grant of the European patent, any person may give notice to the European Patent Office of opposition to the European patent granted. Notice of opposition shall be filed in a written reasoned statement. It shall not be deemed to have been filed until the opposition fee has been paid. (Art. 99(1) European Patent Convention).

Description

[0001] This invention relates to ski simulators in the form of inclined treadmills. Such simulators may be used either for teaching skiing technique, or they may be used as an exercise apparatus, either for general fitness, or more specifically for training the muscle groups used in the sport of skiing.

[0002] US 5,162,029 discloses a ski simulator comprising an inclined deck having a moving belt of material with a low coefficient of friction. A hand rail is provided towards the front of the simulator which the skier holds to maintain a position on the ski deck. A support rail is also provided behind the skier which supports a belt for attachment to the skier.

[0003] It is also known that the angle of inclination of the ski surface may be adjustable and that the speed of the treadmill may be adjusted accordingly. A known apparatus having adjustable speed and angle inclination requires a supervisor to be present during use of the apparatus in order to continuously vary the speed of the treadmill according to the way the user of the apparatus is skiing.

[0004] In addition to the problem of supervision, a further problem with the system described above is that holding on to a handrail reduces the realism of the ski simulator. For the user to be able to let go of the hand rail, the treadmill speed must result in the skier maintaining a substantially fixed position over the treadmill. If the supervisor of the system described above attempts to achieve this, there will inevitably be some movement of the skier up and down the treadmill as the speed is varied. This requires the treadmill to have an increased length. It is, however, desirable to reduce the overall size of the apparatus to enable it to be incorporated into a gymnasium alongside other fitness equipment.

[0005] According to a first aspect of the application, there is provided an apparatus for simulating a ski slope comprising a ski deck having a surface defined by a continuous belt of material formed in a closed loop around rollers at the front and back of the ski deck, the belt of material being driven so that the surface of the ski deck rides up the slope, the angle of inclination of the deck with respect to a base of the apparatus and the drive speed of the material being controllable, wherein the apparatus further comprises a handrail towards the front of the deck, and wherein the angles of inclination of the handrail with respect to the base and with respect to the surface vary as the angle of inclination of the deck is varied.

[0006] This arrangement of the handrail can be configured such that the natural position of the skier on the ski deck when holding the handrail remains substantially fixed as the angle of inclination of the ski deck is varied. In this way, the area of the ski deck can be minimised because the user remains substantially static with respect to the ski deck.

[0007] Preferably, a support rail is provided towards

the back of the deck, and the angles of inclination of the support rail with respect to the base and with respect to the surface also vary as the angle of inclination of the deck is varied. The support rail is preferably provided with a cut-off switch coupled to the user of the apparatus, such that if the user falls the cut-off switch is actuated.

[0008] The movement of the support rail is therefore designed to keep the user at a fixed distance from the support rail, so that the cut-off switch remains functional at all angles of inclination of the ski deck.

[0009] Preferably, the angles of inclination of the handrail and of the support rail with respect to the base change by an amount less than the change in the angle of inclination of the deck. It has been found that the inclination of the handrail and the support rail should not remain fixed with respect to the base, but neither should they remain fixed with respect to the ski deck, when the angle of inclination of the ski deck changes. It has been found that, for optimum comfort and positioning of the skier, the handrail and support rail should tilt, but to a lesser extent than the angular movement of the ski deck.

[0010] The angle of inclination of the handrail with respect to the base may need to change by a different amount to the angle of inclination of the support rail with respect to the base, as the ski deck moves.

[0011] The support rail and the hand rail may each have an extendable base, and the base of the hand rail and of the support rail may then be positionally fixed with respect to the base, and a support part of the hand rail and of the support rail may then be positionally fixed with respect to the deck. The base and the deck thus constitute a linkage mechanism which governs the angular movement of the support rail and the hand rail as the angle of inclination of the deck is varied.

[0012] The extendable base of the hand rail and of the support rail may comprise at least one hydraulic cylinder, with the hydraulic cylinder at the base of the support rail being actuated to vary the angle of inclination of the deck. Alternatively, an electric motor or other arrangement may provide the extension of the base of one of the support rail or the hand rail, which varies the inclination of the deck.

[0013] The axis about which the deck is able to pivot is preferably selected such that the angle of inclination of the handrail with respect to the base changes by a different amount to the angle of inclination of the support rail with respect to the base when the angle of inclination of the ski deck is varied.

[0014] The height of the hand rail above the deck may also be varied as a function of the angle of inclination, so that the hand rail is at a height corresponding to the correct position of the hands for holding ski poles.

[0015] According to a second aspect of the present application, there is provided an apparatus for simulating a ski slope comprising a ski deck having a surface defined by a continuous belt of material formed in a closed loop around rollers at the front and back of the ski deck, the belt of material being driven so that the surface of the ski

deck rides up the slope, the angle of inclination of the deck with respect to a base of the apparatus and the drive speed of the material being controllable, wherein the apparatus further comprises a feedback system for controlling the drive speed as a function of the performance of the user.

[0016] The use of feedback enables the speed to be controlled so that the skier can remain at a substantially fixed position, which may avoid the need for a hand rail. The feedback system may comprise a position sensor for detecting movement of the user up or down the slope, wherein if movement is detected towards the front of the deck the drive speed is increased and if movement is detected towards the back of the slope the drive speed is reduced.

[0017] Alternatively and preferably, the apparatus may further comprise a hand rail towards the front of the deck and wherein the feedback system comprises a sensor for detecting the force applied by the user to the handrail, wherein if a force is detected on the handrail towards the front of the deck the drive speed is increased and if a force is detected on the handrail towards the back of the slope the drive speed is reduced. The use of force feedback from the handrail provides a simple feedback system. Once an appropriate speed has been reached corresponding to the manner in which the user is skiing, the user may let go of the hand rail and maintain a constant skiing rhythm. If the skier then wishes to ski in a different manner, for example with sharper turns, he can then hold on to the handrail, and the sharper turns will cause him to pull back on the handrail. Consequently, the speed will increase and the skier can then maintain a rhythm with sharper turns at a higher speed, and can again let go of the hand rail. Thus, once the user has adopted a particular skiing rhythm the apparatus will self-calibrate to provide the optimum skiing sensation.

[0018] The handrail may be pivoted at its base, and the force sensor then detects the pivoting force of the handrail, forwards or backwards.

[0019] The drive speed is preferably varied by up to predetermined maximum amounts above and below a default drive speed associated with the angle of inclination. This default speed may be selected as a function of the weight of the user.

[0020] According to a third aspect of the application, there is provided an apparatus for simulating a ski slope comprising a ski deck having a surface defined by a continuous belt of material formed in a closed loop around rollers at the front and back of the ski deck, the belt of material being driven so that the surface of the ski deck rides up the slope, the angle of inclination of the deck with respect to a base of the apparatus and the drive speed of the material being controllable, wherein the apparatus comprises a card reader for reading a card of a user, and wherein the card reader is arranged to access information on the card and to cause the maximum angle of inclination of the deck to be limited dependent on that information.

[0021] This enables the operator of the simulator to ensure that users have undergone sufficient training to be competent to use the apparatus safely, because their card will be updated to reflect their level of competence, so that they are only provided access to ski runs appropriate for their ability. The card reader may also be for reading information concerning the weight of the user, the apparatus determining the belt speed for different angles of inclination from the weight information. The card may be a magnetic swipe card or a swipe card.

[0022] According to a fourth aspect of the application, there is provided an apparatus for simulating a ski slope comprising a ski deck having a surface defined by a continuous belt of material formed in a closed loop around rollers at the front and back of the ski deck, the belt of material being driven so that the surface of the ski deck rides up the slope, the angle of inclination of the deck with respect to a base of the apparatus and the drive speed of the material being controllable, the apparatus having a plurality of settings corresponding to different simulated ski conditions, each setting defining an associated drive speed and angle of inclination.

[0023] The provision of a number of settings enables a user of the apparatus to select a setting corresponding to their skiing ability or the effort to be exerted during fitness training, and to use the apparatus without supervision. Preferably, the relationship between the drive speed and the angle of inclination for each setting can be varied as a function of the weight of the user. In this way, the default setting will be approximately sufficient for the drive speed to support the user without the user needing to apply a large force to the handrail.

[0024] According to a fifth aspect of the invention, there is provided an apparatus for simulating a ski slope comprising a ski deck having a surface defined by a continuous belt of material formed in a closed loop around rollers at the front and back of the ski deck, the belt of material being driven so that the surface of the ski deck rides up the slope, the angle of inclination of the deck with respect to a base of the apparatus and the drive speed of the material being controllable, wherein the angle of inclination of the deck is controlled by at least one hydraulic cylinder having a first cylindrical chamber on one side of a piston and a second annular chamber on the opposite side of the piston, wherein the area of a section through the first chamber is approximately double the area of a section through the second chamber, and wherein a pressure is applied to both chambers to move the piston in one direction, whereas a pressure is applied only to the second chamber to move the piston in an opposite direction.

[0025] This hydraulic cylinder arrangement enables the rising and falling of the ski deck to occur at the same speed, even with a single constant pressure source for the hydraulic cylinder. Accurate control of the speed at which the ski deck rises and falls enables the speed of the belt to be varied appropriately during the raising and lowering of the ski deck. Thus, the drive speed is prefer-

ably controlled automatically to vary in a predetermined manner as the angle of inclination is varied.

[0026] According to a sixth aspect of the invention, there is provided an apparatus for simulating a ski slope comprising a ski deck having a surface defined by a continuous belt of material formed in a closed loop around rollers at the front and back of the ski deck, the belt of material being driven so that the surface of the ski deck rides up the slope, the angle of inclination of the deck with respect to a base of the apparatus and the drive speed of the material being controllable, wherein the belt comprises a backing layer, a rubber ply layer bonded to the backing layer, and a polypropylene matting bonded to the rubber ply layer, the matting having bundles of strands projecting through openings in a support layer of the matting, the strands having a length between 15 and 30mm and the spacing between adjacent bundles of strands being less than 5mm.

[0027] According to a seventh aspect of the invention, there is provided an apparatus for simulating a ski slope comprising a ski deck having a surface defined by a continuous belt of material formed in a closed loop around rollers at the front and back of the ski deck, the belt of material being driven so that the surface of the ski deck rides up the slope, the angle of inclination of the deck with respect to a base of the apparatus and the drive speed of the material being controllable, wherein the rotation axis of one of the rollers can be tilted, and wherein the apparatus further comprises a tracking control system comprising a sensor on each side of the belt for detecting lateral movement of the belt, and wherein if lateral movement of the belt is detected, the rotation axis is tilted for a predetermined time period.

[0028] The features of each of the seven aspects of the invention may be combined in any combination to produce an apparatus for simulating a ski slope benefiting from advantages provided by this invention.

[0029] The apparatus may be provided with a screen at the front of the deck for displaying images selected according to the setting of the angle of inclination of the deck. Aspects of this invention may enable the deck to have an area of less than 5 square meters. For example, the deck may have dimensions of approximately 2 meters x 2 meters, or even 1.5 meters x 1.5 meters. These dimensions make it practical for the apparatus to be placed alongside conventional gymnasium equipment.

[0030] Examples of the present invention will now be described in detail with reference to the accompanying drawings, in which:

Figure 1 shows an apparatus for simulating a ski slope according to the invention;
 Figure 2 shows a force sensor arrangement used in the apparatus of Figure 1;
 Figure 3 is a diagram illustrating how the position of the skier changes as the angle of inclination of the deck varies;
 Figure 4 shows in greater detail the arrangement

used in the apparatus of Figure 1;

Figure 5 shows a hydraulic piston arrangement used in the apparatus of Figure 1;

Figure 6 shows an electric actuator used in the apparatus of Figure 1; and

Figure 7 shows a modification to the apparatus of Figure 1 incorporating a screen.

[0031] Figure 1 shows an apparatus 10 for simulating a ski slope. The apparatus 10 comprises a ski deck 12 having a surface defined by a continuous belt of material 14 formed in a closed loop around rollers at the front and back of the ski deck 12. The belt 14 is driven around the rollers, for example by an electric motor, so that the upper surface of the belt 14 travels in the direction represented by arrow 16, which is up the slope when it is inclined. The apparatus 10 has a fixed base 18 and an upper frame 20. The front and back rollers are supported by the upper frame 20, and the upper frame 20 and the belt 14 can pivot about an axis, which may coincide with the axis of rotation of the front roller. This enables the back of the deck 12 to be raised, as represented by arrow 22. In this way, the angle of inclination of the deck 12 with respect to the base 18 is controllable. Furthermore, the drive speed of the belt of material 14 is also controllable, so that the drive speed is appropriate for the angle of inclination of the deck 12.

[0032] The apparatus further comprises a handrail 24 towards the front of the deck 12 and a support rail 26 towards the back of the deck 12. A cut-off switch 28 is mounted on the support rail 26, and is coupled to a belt 30 to be worn by the user of the apparatus. The belt 30 and the cut-off switch 28 are arranged such that the deck 12 is stopped if the user falls over.

[0033] During use of the apparatus, the user wears a pair of skis, or a snowboard, and stands in the middle of the deck 12 holding the handrail 24, and wearing the belt 30.

[0034] When the ski deck 12 is raised to an incline, the speed of the belt of material 14 is selected such that the forces on the skier up and down the slope are approximately equal, so that the user is in equilibrium. This equilibrium will depend not only on the speed of the belt and the angle of inclination of the belt, but also on the weight of the user, the surface of the skis used and the skiing style adopted by the user. To ensure the user remains on the deck 12, the handrail 24 is held during use of the apparatus.

[0035] To the extent described above, the apparatus is known. Improvements to the basic operation of the device described above are set out below.

[0036] The apparatus is provided with a control panel 31 which provides a number of settings corresponding to different ski runs. Each setting defines an associated drive speed and angle of inclination which can be reached automatically by the apparatus. The skier can thus select a setting corresponding to their skiing ability or the effort to be exerted during fitness training, and to use the ap-

paratus without supervision. Preferably, the relationship between the drive speed and the angle of inclination for each setting can be varied as a function of the weight of the user, and the control panel 31 thus has a weight input function for this purpose. In this way, the default setting will be approximately sufficient for the drive speed to support the user without the need to lean heavily or pull back heavily on the hand rail.

[0037] A preferred belt material has been found to be polypropylene matting, which has similar surface properties to fresh snow. A problem with the use of such material for artificial ski slopes has been that the performance degrades when the surface becomes dirty. The use of this material in the apparatus of the invention is particularly suitable because the rotation of the belt around the rollers provides a self-cleaning operation.

[0038] In particular, a close pile polypropylene matting with short strand length has been found to best simulate the sensation of skiing on snow. In one example, the belt comprises a conventional frictional belt as a backing layer, a 3mm rubber ply layer bonded to the belt, and the close pile matting bonded to the rubber ply layer. The matting has strand lengths of between 15 and 25mm, preferably around 20mm. The spacing between adjacent bundles of strands projecting through individual holes in the backing of the matting is less than 6mm, and preferably around 5mm.

[0039] In one example, the use of a feedback system for speed control is also provided. Figure 2 shows a force sensor arrangement 40 associated with the handrail 24 for detecting the force applied to the handrail 24 by the user. The handrail 24 is pivoted at its base at pivot point 42 which enables the hand rail to tilt with respect to the base 18. Furthermore, the hand rail is positionally fixed with respect to the upper frame 20 at a pivot connection 43. Some slack is provided in this coupling to enable force detection, explained below.

[0040] A spring arrangement 44 biases the handrail 24 into a central default position with respect to the upper frame 20. When a force is applied to the handrail 24 either forwards or backwards, the handrail 24 is moved away from the central position, and this is detected by the force feedback system 40. Detection of movement of the handrail 24 may either be by a contact arrangement or by pressure sensors. The pivoting of the handrail 24 either forward or backward is limited by the oval opening 47 which houses the pivot 43 and in the limit position a contact closes to indicate that a force greater than a preset minimum is being applied to the handrail 24 either in a forward or a backward direction. The pivot connection between the upper and lower frames is not shown in Figure 2, but as described above this may coincide with the axis of the front roller.

[0041] The force feedback signal is used to control the drive speed of the belt of material 14, so that when a force is detected on the handrail towards the front of the slope, the drive speed is increased, and when a force is detected on the handrail towards the back of the deck,

the drive speed is reduced. In this way, the speed of the belt of material 14 is controlled automatically to match the skiing style, the weight, and the skis of the user to maintain the user in equilibrium. For example, if the user decides to practice sharper turns, this provides increased resistance which slows the user down. The effect of this is that the user will be dragged up the slope by the belt of material 14, and he will thereby pull back on the handrail 24. The speed of the belt of material 14 will accordingly be reduced, and a new equilibrium will be found.

[0042] This may enable the skier to let go of the handrail once a rhythm in his skiing has been established.

[0043] In an alternative arrangement, there is no force feedback system, and instead the user may be able to input manually a desired speed or speed change into the control panel 31, whilst holding the hand rail 24 when getting used to the new speed setting.

[0044] Figure 3 illustrates the positioning of the skier on the ski deck 12 at different angles of inclination of the deck.

[0045] As shown in Figure 3A for no incline, the position of the handle of the handrail 24 is selected such that when a skier holding the handrail 24 has the correct stance, the skis are positioned approximately in the middle of the ski deck 12. When the angle of inclination is increased, as shown in Figure 3B, the skier's stance changes and in particular the skier's body remains substantially upright whereas the skier's knees are more flexed.

[0046] Figure 3B illustrates the position of the skier over the deck 12 when the handrail 24 and the support rail 26 remains at the same inclination with respect to the base. This could be achieved using a parallelogram coupling arrangement. The applicant has recognised that if the angle of inclination of the handrail with respect to the base remains constant then the skier moves towards the back of the ski deck, as shown, and becomes closer to the support rail 26.

[0047] Figure 3C illustrates the position of the skier over the deck 12 when the handrail 24 and the support rail 26 is pivoted together with the deck 12, in other words the angles of inclination of the handrail with respect to the ski surface remains constant. The applicant has recognised that, as can be seen in Figure 3C, the result is that the skier moves towards the front of the ski deck.

[0048] Both of these situations require an enlarged skiing surface, since the position of the skier does not remain constant as the angle of inclination of the ski deck is changed. The position of the hand rail is also no longer comfortable in either situation.

[0049] A preferred implementation of the invention shown in Figure 3D thereby ensures that the angles of inclination of the handrail with respect to the base and with respect to the surface vary as the angle of inclination of the deck is varied. Furthermore, the angles of inclination of the support rail with respect to the base and with respect to the surface also vary as the angle of inclination of the deck is varied.

[0050] The movement of the hand rail ensures a constant position of the user over the ski deck, and the movement of the support rail 26 is intended to provide a constant distance between the belt 30 and the cut-off switch 28 provided on the support rail 26, so that the cut-off switch remains operative. The constant user position enables the area of the deck to be reduced. Preferably, short skis are also used, to reduce the required area of the deck 12.

[0051] Figure 4 shows in greater detail the system of linkages which provides the angular relationship between the handrail 24 and the support rail 26 shown in Figure 3D. As already shown in Figure 2, the base 42 of the hand rail 24 is positionally fixed with respect to the base 18, and a pivot point 43 of the hand rail is positionally fixed with respect to the deck 20. The distance between these two points 42 and 43 is variable, as a hydraulic cylinder arrangement is provided. Similarly, the base 50 of the support rail 26 is positionally fixed with respect to the base 18, and a support part 1 of the hand rail is positionally fixed with respect to the deck 20. The distance between these two points 50 and 41 is also variable, as a hydraulic cylinder arrangement 52 is provided.

[0052] Thus, the distance between points 42 and 50 is fixed, as well as the distance between points 43 and 51. The pivoting of the deck takes place around a fixed pivot axis 54 which may or may not coincide with the axis of the front roller. The position of this axis 54 governs the way the angles of the hand rail and of the support rail vary as the deck angle is varied.

[0053] One preferred system of angles is represented in Figure 4. As shown, the hand rail angle with respect to the deck 12 changes more slowly than the support rail angle with respect to the deck 12. For an incline of 30 degrees, the example illustrated in Figure 4 gives rise to an angular movement with respect to the deck of 13.7 degrees for the support rail and 12.4 degrees for the hand rail.

[0054] Typically, the angle of the hand rail and of the support rail with respect to the base may change by between $1/3$ and $2/3$ of the change in the angle of inclination of the deck 20. Correspondingly, the angle of the hand rail and of the support rail with respect to the deck then changes by between $2/3$ and $1/3$ of the change in the angle of inclination of the deck 20.

[0055] A further possibility is to alter the height of the hand rail above the deck, as a function of the angle of inclination. By "height" is meant the length of the upright arm of the hand rail from the deck. The distance between points 42 and 43 may again vary passively, as a function of the angle of inclination. However, the length of the hand rail above the point 43 may also be controllable by an independent drive mechanism. The hand rail may have an outer sleeve which is slidable over an inner core, and this slide is then controlled by the drive mechanism. In particular, as the slope increases, the hand rail rises, so that it remains in a position corresponding to the correct position in which the ski poles are to be held. This

is shown in dotted lines in Figure 3D.

[0056] Figure 5 shows the operation of the hydraulic cylinder arrangement 52 used to raise and lower the ski deck 20. The cylinder arrangement has a first cylindrical chamber 54 on one side of a piston 56 and a second annular chamber 58 on the opposite side of the piston 56. The area of a section through the first chamber 54 is approximately double the area of a section through the second chamber 58.

[0057] The base of the piston rod 60 is fixed to the base 18 of the apparatus, and the sleeve 62 defines the contact point 51 where the support rail 26 is fixed to the upper frame 20. In order to raise the ski deck 20, a pressure from a pressure source 64 is applied to both chambers by means of a valve arrangement 66. This results in a net force driving the support rail upwards. In order to lower the ski deck 20, the pressure from the pressure source 64 is applied only to the second chamber 58, which results in a force driving the support rail downwards.

[0058] By virtue of the area relationship described above, the force up and down is equal, so that the deck can be controlled with a single, constant value, pressure source, to give equal raising and lowering speeds. During lowering of the ski deck, the effect of gravity acting to increase the speed of decline of the deck is counteracted by the fluid resistance of an outlet valve from the first chamber. It is desirable to know the speed at which the deck 20 rises and falls so that the speed of the belt 14 can be controlled in appropriate manner when the incline of the deck is being changed.

[0059] Only one of the hydraulic cylinders needs to be driven, since the support rail and hand rail are coupled by the linkage arrangement. Preferably, the support rail is driven by the hydraulic cylinder arrangement of Figure 5.

[0060] It is also possible to use an electrical drive scheme for raising and lowering the ski deck, again with the angles of the rails being governed by the angle of inclination of the deck. All that is required is a drive arrangement for raising and lowering the deck, and the cylinder arrangement by which the bases of the hand rail and support rail are extendable may then be entirely passive.

[0061] Figure 6 shows schematically one possibility in which the rear part of the deck is caused to raise and lower using a scissor arrangement, in which an electric ball screw actuator 72 is used to control the extension or compression of the scissor arrangement, and thereby the height of the back of the deck. This provides a rapidly controllable movement. The pivot connections of the rails provide the desired angular movement of the rails as the deck is raised and lowered.

[0062] Figure 7 shows a modification to the apparatus of Figure 1 incorporating a screen. The images are selected according to the setting of the angle of inclination of the deck, to improve the simulation. The screen may be used to show images and runs of a resort where a

skier will be going while he or she is exercising in preparation for the holiday. The skier can thus get a feeling for the resort in advance. When the apparatus is used in a gymnasium, the screen may be used to sell advertising space to ski resort organisations or ski equipment suppliers.

[0063] The screen may also include a camera so that the user can see images of himself or herself, and/or a mirror.

[0064] The front of the deck may also be provided with a fan 80 or a series of fans 80, and the number of fans actuated, or else the speed of the fan or fans, is controlled as a function of the angle of inclination, to represent the skier's speed through the air.

[0065] The ski deck is preferably mounted over the front and rear roller without being constrained laterally. The forces on the deck may result in lateral movement of the belt. Figure 7 shows a tracking control system to ensure correct alignment of the belt. A first sensor 82 is provided on each side of the belt. If the belt moves laterally enough to cover the sensor, reflection from the underside of the belt can be detected, and the axis 84 of the front roller can be shifted appropriately for a fixed time period, to force the belt back to a central lateral position. A second series of sensors 86 will detect further misalignment, indicating incorrect operation of the automatic tracking control system, and act as a safety cut-out. The sensors 82,86 may be detect reflection (for example comprising a light source such as a phototransistor and a light detector such as a photodiode) or alternatively a light source may be mounted above or below the belt with a light detector mounted on the opposite side of the belt, so that a light path is interrupted by the belt when it shifts laterally to a sufficient degree.

[0066] The outer perimeter of the deck may also be provided with line-of-sight sensors, so that any object projecting off the deck (such as a wrongly positioned ski) can cause a safety cut-out. These sensors may be provided all around the deck, or at least at the back of the deck.

[0067] It is described above that the user of the simulator will be able to ski in such a manner to reach an equilibrium with the belt speed. Of course, this may not be possible for a beginner, who will need to hold on to the hand rail. However, it may be considered desirable from a safety point of view for these beginners to be supervised. A further aspect of the invention provides users with an identity card which can be read by the simulator, which then allows the user to operate the machine to speeds or angles of inclination which match the user's level of experience. This identity card comprises a smart card, and a user may then be required to undergo basic training before obtaining a smart card, or before the smart card enables the user to operate the simulator without supervision.

[0068] Figure 7 shows schematically a smart card reader 90 as part of the control panel 31. By way of example, a user may be required to have three safety train-

ing lessons before the smart card will allow them to use the simulator independently. This enables a gym having the simulator to ensure the safety of users of the simulator. Once the user's smart card has been updated to indicate that the three lessons have been completed, the user may be able to ski on low gradient (green) slopes independently. An additional lesson will then allow the user access to the next gradient of slope. There may be four further slope gradients (blue, red, black, double diamond black), and the user may therefore be required to complete a seven lesson training schedule before being allowed to use the simulator to its full capability.

[0069] The user may choose to see a pre-recorded video taken by a skier skiing the selected run, or else footage or information concerning a chosen resort. During a lesson, the footage of the run being skied may include a skier to be followed. The skier being followed will then be skiing at a level corresponding to the level of the lesson, so that the user will be instructed to copy the skier in front. This keeps the user looking forward and in an upright stance. A user authorised to use the simulator independently may also choose to follow a skier. The smart card may also be used to enable a user to follow a training schedule, with the simulator providing a tailor-made training routine for the user, in preparation for a ski holiday, for example.

[0070] The smart card also contains information concerning the weight of the user, so that the ratio of angle of inclination to belt speed can be determined. It can also contain information concerning the height of the user, so that the extension of the hand rail can be tailored to the user, so that the users hands will always be positioned in the correct position for holding the ski poles.

[0071] In the examples described above, it is assumed that for a given run, the angle of inclination remains constant. Instead, when recording footage of a run to be featured by the simulator, gradient information may be recorded at regular intervals, for example every metre. This can be achieved by measuring accurately the altitude using a GPS system. When the user skis the run, the angle of inclination and the belt speed may vary to mirror the image on the screen at that time.

[0072] In respect of the feedback system for drive speed control, a force feedback system associated with the hand rail has been described in detail. However, other systems for detecting whether the user is tending to travel up or down the slope may be envisaged. For example a sensor may be provided for detecting the position of the user's boots, which should remain at a substantially constant height up the slope. The front or back of the user's skis will naturally rise and fall up and down the slope during turns, whereas the user's feet will not. A light probe and sensor arrangement may be provided for this purpose. Alternatively, the position of the body of the user may be monitored, either by attachment of a sensor to the user, or again by monitoring with an optical system. All of these possibilities are intended to be within the scope of the invention.

Claims

1. An apparatus (10) for simulating a ski slope comprising a ski deck (12) having a surface defined by a continuous belt of material (14) formed in a closed loop around rollers at the front and back of the ski deck, the belt of material being driven so that the surface of the ski deck rides up the slope, the angle of inclination of the deck with respect to a base (18) of the apparatus and the drive speed of the material being controllable, **characterised in that** the belt comprises a backing layer, a rubber ply layer bonded to the backing layer, and a polypropylene matting bonded to the rubber ply layer, the matting having bundles of strands projecting through openings in a support layer of the matting, the strands having a length between 15 and 25mm and the spacing between adjacent bundles of strands being less than 6mm. 5
2. An apparatus as claimed in claim 1, further comprising a handrail (24) towards the front of the deck and wherein the angles of inclination of the handrail with respect to the base and with respect to the surface vary as the angle of inclination of the deck is varied. 10
3. An apparatus as claimed in claim 2, further comprising a support rail (26) towards the back of the deck, and wherein the angles of inclination of the support rail with respect to the base and with respect to the surface also vary as the angle of inclination of the deck is varied. 15
4. An apparatus as claimed in claim 3, wherein the angles of inclination of the handrail and of the support rail with respect to the base change by an amount less than the change in the angle of inclination of the deck. 20
5. An apparatus as claimed in claim 4, wherein the angle of inclination of the hand rail with respect to the base changes by a different amount to the angle of inclination of the support rail with respect to the base. 25
6. An apparatus as claimed in any one of claims 3 to 5, wherein the support rail and the hand rail have an extendable base, and wherein the base of the hand rail and of the support rail is positionally fixed with respect to the base, and a support part of the hand rail and of the support rail is positionally fixed with respect to the deck. 30
7. An apparatus as claimed in claim 6, wherein the extendable base of the hand rail and of the support rail comprises at least one hydraulic cylinder (52), and wherein the hydraulic cylinder at the base of the support rail is actuated to vary the angle of inclination of the deck. 35

8. An apparatus as claimed in claim 6, wherein the axis about which the deck is able to pivot is selected such that the angle of inclination of the handrail with respect to the base changes by a different amount to the angle of inclination of the support rail with respect to the base when the angle of inclination of the ski deck is varied. 40
9. An apparatus as claimed in any one of claims 3 to 8, wherein the support rail is provided with a cut-off switch coupled to the user of the apparatus, such that if the user falls, the cut-off switch is actuated. 45
10. An apparatus as claimed in any one of claims 2 to 9, wherein the height of the hand rail above the deck is varied as a function of the angle of inclination. 50
11. An apparatus as claimed in any preceding claim, wherein the deck has an area of less than 5m². 55

Patentansprüche

1. Eine Vorrichtung (10) zum Simulieren eines Skihangs, die ein Skideck (12) aufweist, das eine Oberfläche aufweist, die durch ein Endlosband aus einem Material (14) definiert ist, das in einer geschlossenen Schleife um Rollen an dem vorderen Ende und dem hinteren Ende des Skidecks gebildet ist, wobei das Materialband so angetrieben wird, dass die Oberfläche des Skidecks den Hang hinauffährt, wobei der Neigungswinkel des Decks bezüglich einer Basis (18) der Vorrichtung und die Antriebsgeschwindigkeit des Materials steuerbar sind, **dadurch gekennzeichnet, dass** das Band eine Trägerschicht, eine Gummilagenschicht, die mit der Trägerschicht verbunden ist, und eine Polypropylenmatte aufweist, die mit der Gummilagenschicht verbunden ist, wobei die Matte Bündel von Strängen aufweist, die durch Öffnungen in einer Halteschicht der Matte vorstehen, und die Stränge eine Länge zwischen 15 und 25 mm aufweisen und die Beabstandung zwischen benachbarten Bündeln von Strängen weniger als 6 mm beträgt. 25
2. Eine Vorrichtung gemäß Anspruch 1, die ferner eine Handschiene (24) zu dem vorderen Ende des Decks hin aufweist, und wobei die Neigungswinkel der Handschiene bezüglich der Basis und bezüglich der Oberfläche variieren, wenn der Neigungswinkel des Decks variiert wird. 30
3. Eine Vorrichtung gemäß Anspruch 2, die ferner eine Halteschiene (26) zu dem hinteren Ende des Decks hin aufweist, und wobei die Neigungswinkel der Halteschiene bezüglich der Basis und bezüglich der Oberfläche ebenfalls variieren, wenn der Neigungswinkel des Decks variiert wird. 35

4. Eine Vorrichtung gemäß Anspruch 3, bei der die Neigungswinkel der Handschiene und der Halteschiene bezüglich der Basis sich um einen Betrag ändern, der geringer ist als die Änderung des Neigungswinkels des Decks.
5. Eine Vorrichtung gemäß Anspruch 4, bei der der Neigungswinkel der Handschiene bezüglich der Basis sich um einen anderen Betrag ändert als der Neigungswinkel der Halteschiene bezüglich der Basis.
6. Eine Vorrichtung gemäß einem der Ansprüche 3 bis 5 bei der die Halteschiene und die Handschiene eine erweiterbare Basis aufweisen, und wobei die Basis der Handschiene und der Halteschiene bezüglich der Basis positionsmäßig fest ist und ein Halteteil der Handschiene und der Halteschiene bezüglich des Decks positionsmäßig fest ist.
7. Eine Vorrichtung gemäß Anspruch 6, bei der die erweiterbare Basis der Handschiene und der Halteschiene zumindest einen hydraulischen Zylinder (52) aufweist, und wobei der hydraulische Zylinder an der Basis der Halteschiene betätigt wird, um den Neigungswinkel des Decks zu variieren.
8. Eine Vorrichtung gemäß Anspruch 6, bei der die Achse, um die sich das Deck drehen kann, derart ausgewählt ist, dass der Neigungswinkel der Handschiene bezüglich der Basis sich um einen anderen Betrag ändert als der Neigungswinkel der Halteschiene bezüglich der Basis, wenn der Neigungswinkel des Skidecks variiert wird.
9. Eine Vorrichtung gemäß einem der Ansprüche 3 bis 8, bei der die Halteschiene mit einem Abschaltswitcher ausgestattet ist, der mit dem Benutzer der Vorrichtung gekoppelt ist, derart, dass der Abschaltswitcher betätigt wird, wenn der Benutzer fällt.
10. Eine Vorrichtung gemäß einem der Ansprüche 2 bis 9, bei der die Höhe der Handschiene über dem Deck in Abhängigkeit des Neigungswinkels variiert wird.
11. Eine Vorrichtung gemäß einem der vorhergehenden Ansprüche, bei der das Deck eine Fläche von weniger als 5 m² aufweist.

Revendications

1. Appareil (10) pour simuler une pente de ski, comprenant une plate-forme de ski (12) ayant une surface définie par une courroie continue de matériau (14) formée en une boucle fermée autour de rouleaux à l'avant et à l'arrière de la plate-forme de ski, la courroie de matériau étant entraînée de telle façon que la surface de la plate-forme de ski monte le long

de la pente, l'angle d'inclinaison de la plate-forme par rapport à une base (18) de l'appareil et la vitesse d'entraînement du matériau pouvant être commandés,

caractérisé en ce que

la courroie comprend une couche de doublage, une couche d'un lé en caoutchouc collé sur la couche de doublage, et une natte de polypropylène collée sur la couche de caoutchouc, ladite natte ayant des faisceaux de fibres qui se projettent à travers des ouvertures dans une couche de support de la natte, et dans lequel les fibres ont une longueur entre 15 et 25 mm, et l'espacement entre faisceaux adjacents de fibres étant inférieur à 6 mm.

2. Appareil selon la revendication 1, comprenant en outre une balustrade (24) vers l'avant de la plate-forme, et dans lequel les angles d'inclinaison de la balustrade par rapport à la base et par rapport à la surface varient lorsque l'on fait varier l'angle d'inclinaison de la plate-forme.
3. Appareil selon la revendication 2, comprenant en outre un rail de support (26) vers l'arrière de la plate-forme, et dans lequel les angles d'inclinaison du rail de support par rapport à la base et par rapport à la surface varient également lorsqu'on fait varier l'angle d'inclinaison de la plate-forme.
4. Appareil selon la revendication 3, dans lequel les angles d'inclinaison de la balustrade et du rail de support par rapport à la base changent d'une valeur inférieure du changement de l'angle d'inclinaison de la plate-forme.
5. Appareil selon la revendication 4, dans lequel l'angle d'inclinaison de la balustrade par rapport à la base change d'une valeur différente de l'angle d'inclinaison du rail de support par rapport à la base.
6. Appareil selon l'une quelconque des revendications 3 à 5, dans lequel le rail de support et la balustrade comprennent une base extensible, et dans lequel la base de la balustrade et du rail de support est fixe en position par rapport à la base, et une partie de support de la balustrade et du rail de support est fixée en position par rapport à la plate-forme.
7. Appareil selon la revendication 6, dans lequel la base extensible de la balustrade et du rail de support comprend au moins un cylindre hydraulique (52), et dans lequel le cylindre hydraulique à la base du rail de support est actionné pour faire varier l'angle d'inclinaison de la plate-forme.
8. Appareil selon la revendication 6, dans lequel l'axe autour duquel la plate-forme est capable de pivoter est choisi de telle manière que l'angle d'inclinaison

de la balustrade par rapport à la base change d'une valeur différente de l'angle d'inclinaison du rail de support par rapport à la base quand l'angle d'inclinaison de la plate-forme de ski est varié.

5

9. Appareil selon l'une des revendications 3 à 8, dans lequel le rail de support est pourvu d'un commutateur de coupure couplé à l'utilisateur de l'appareil, de telle sorte que si l'utilisateur fait défaillance, le commutateur de coupure est actionné.

10

10. Appareil selon l'une quelconque des revendications 2 à 9, dans lequel la hauteur de la balustrade au-dessus de la plate-forme est variée en fonction de l'angle d'inclinaison.

15

11. Appareil selon l'une quelconque des revendications précédentes, dans lequel la plate-forme a une superficie inférieure à 5 m².

20

25

30

35

40

45

50

55

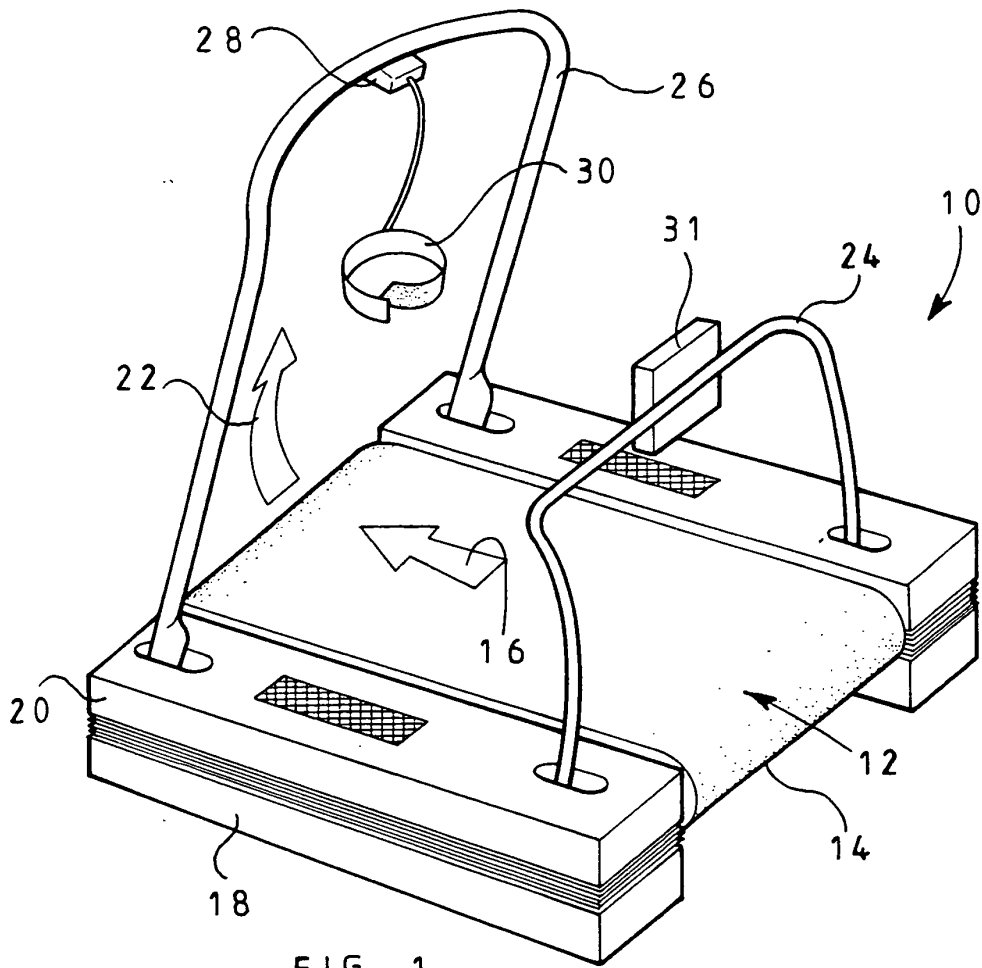

FIG 1

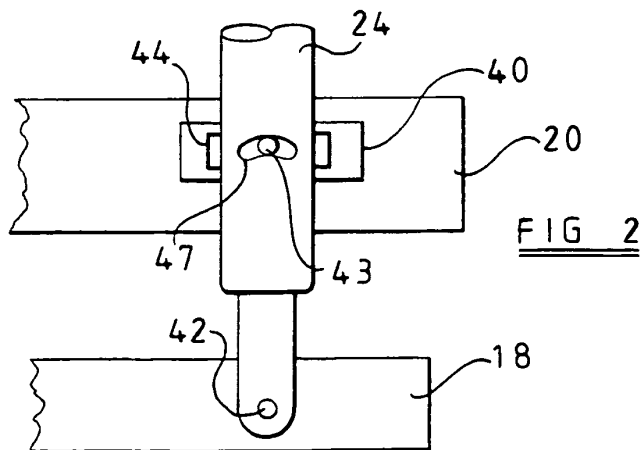
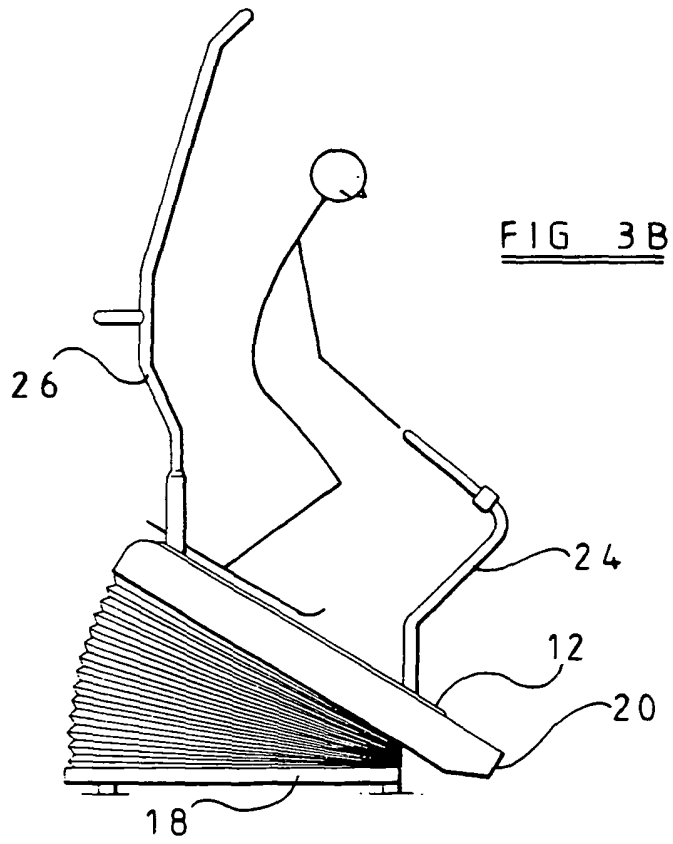
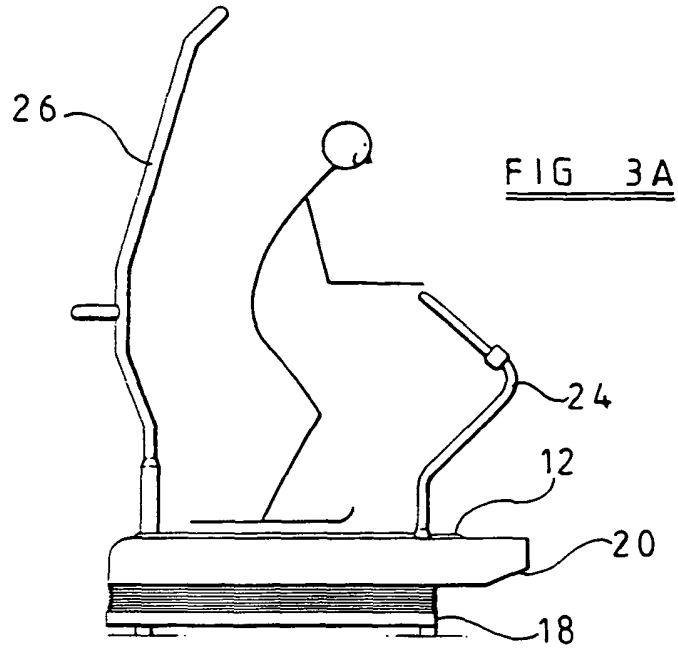
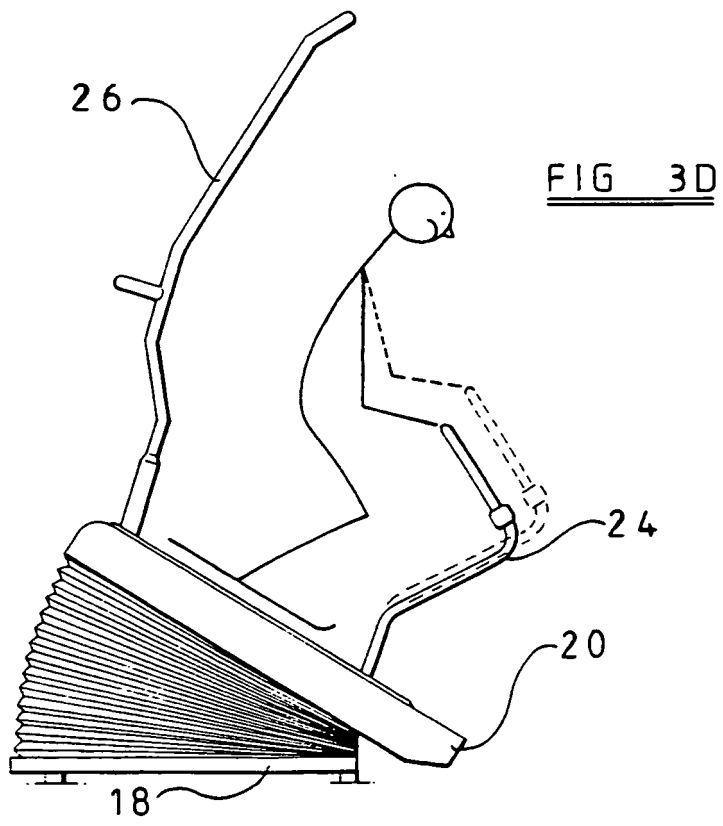
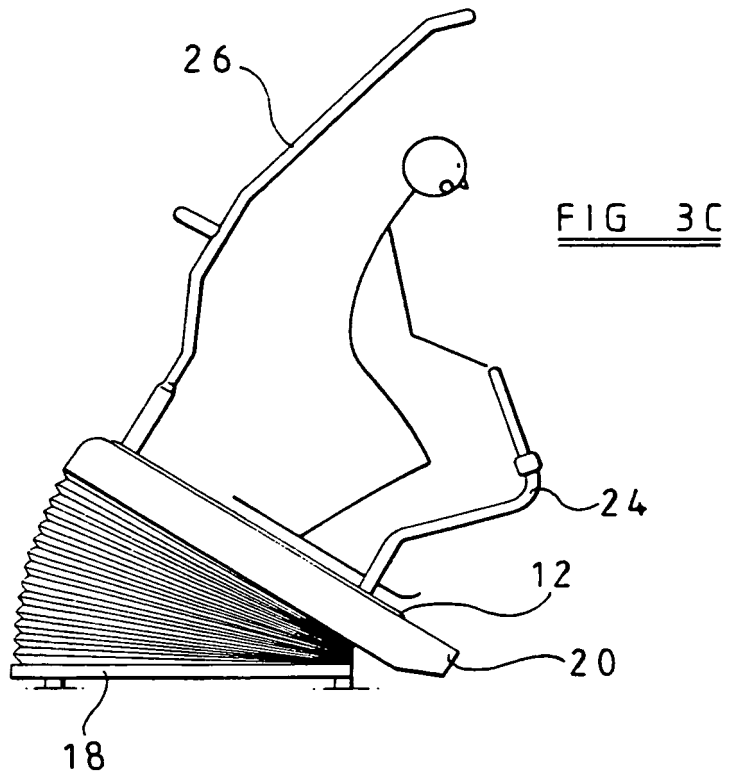
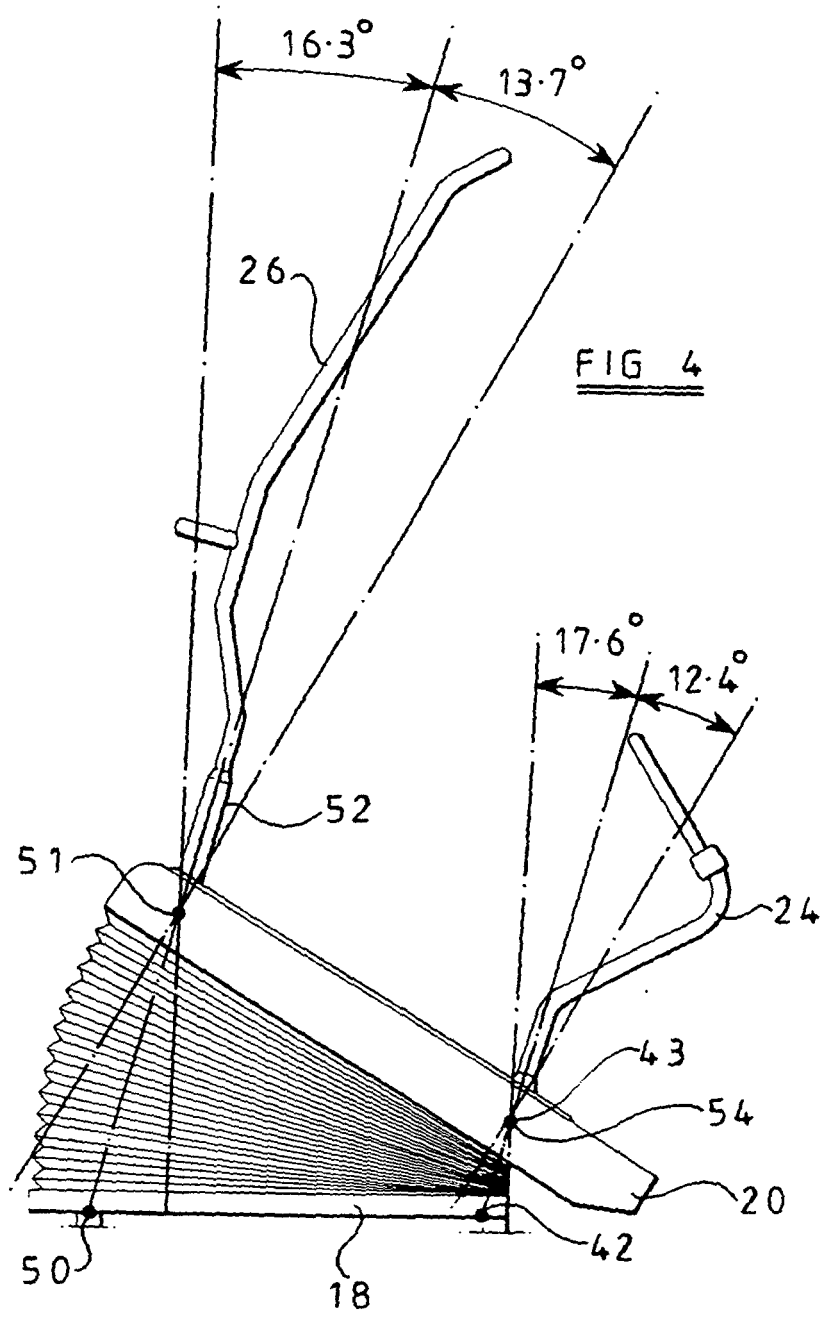
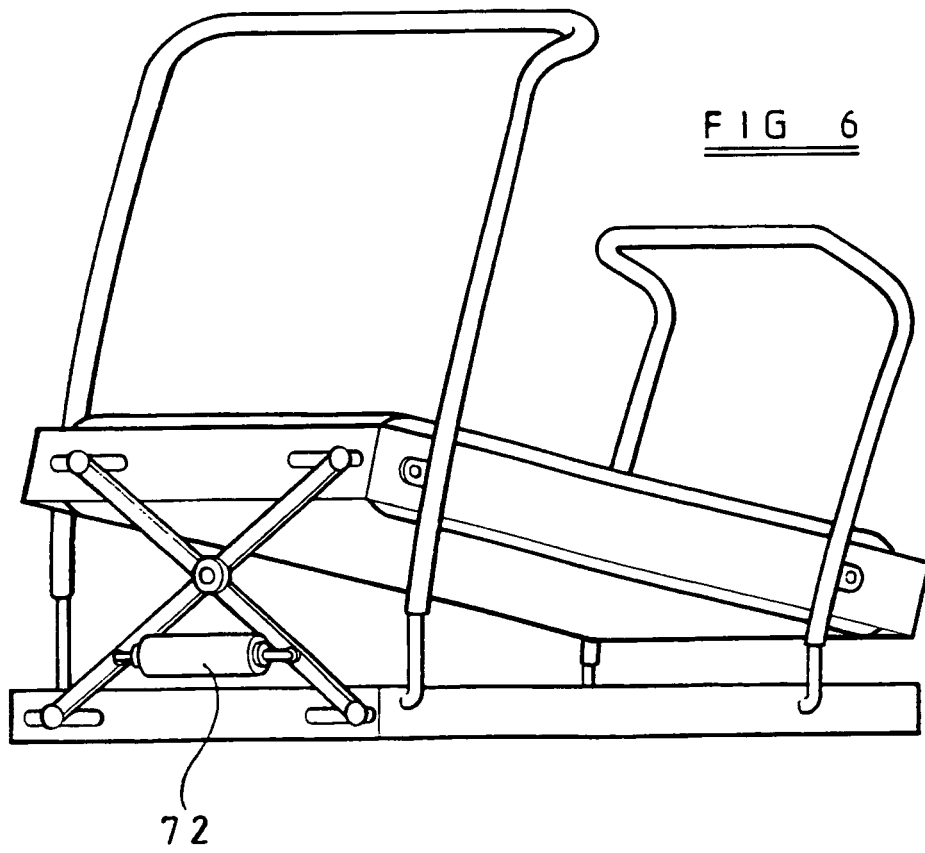
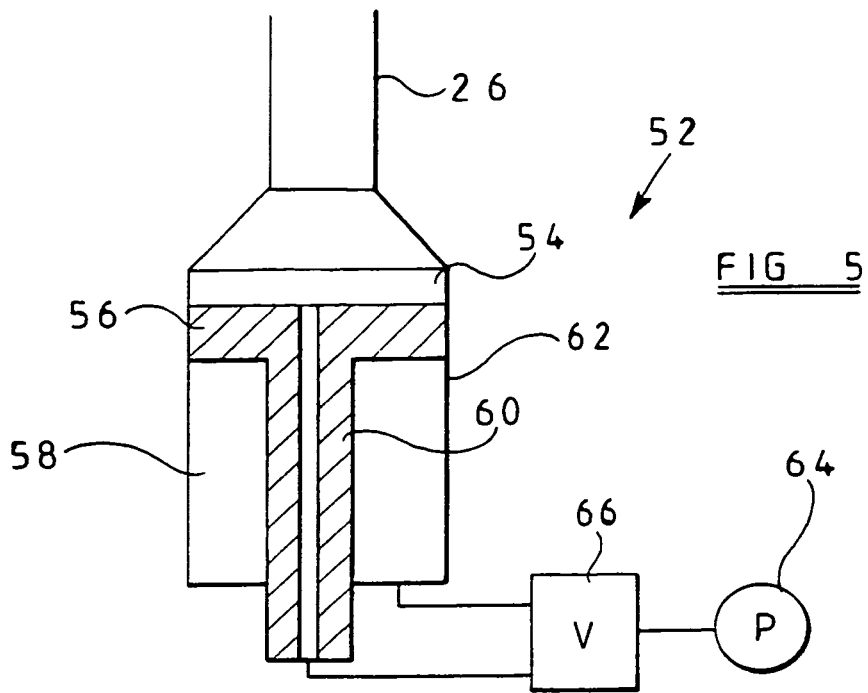

FIG 2









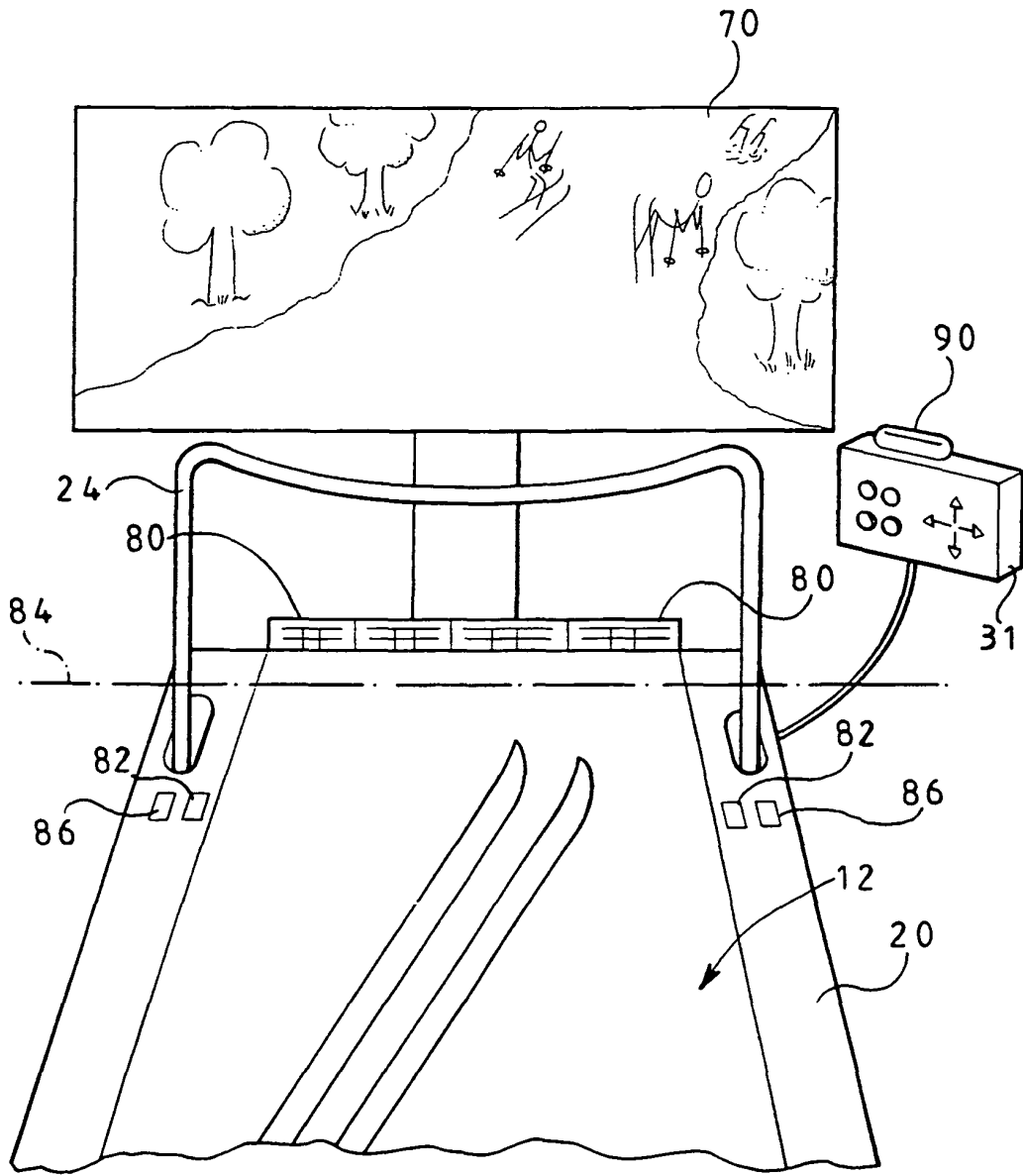

FIG 7