

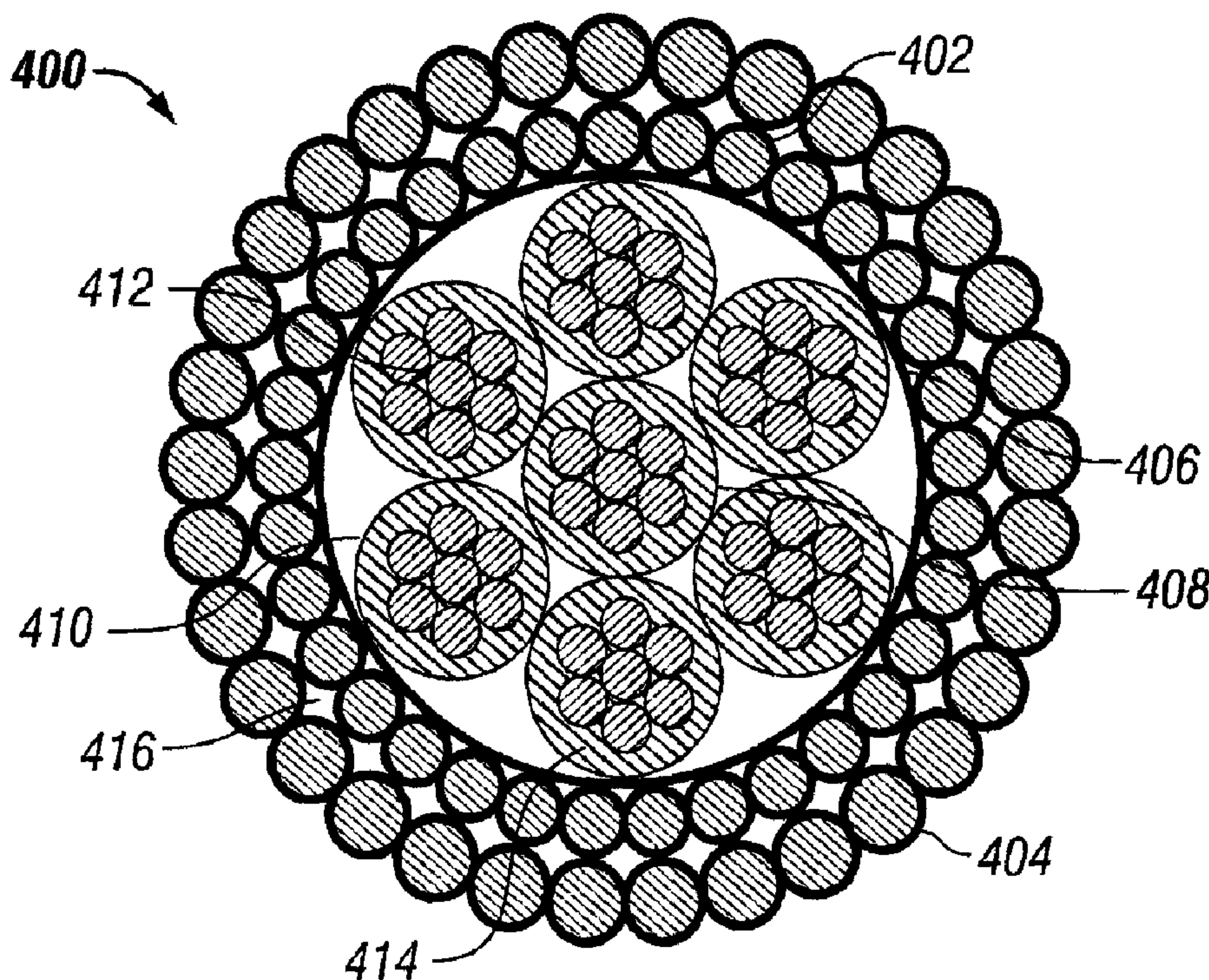

(22) Date de dépôt/Filing Date: 2006/06/15  
 (41) Mise à la disp. pub./Open to Public Insp.: 2006/12/15  
 (45) Date de délivrance/Issue Date: 2015/03/17  
 (30) Priorité/Priority: 2005/06/15 (US11/153,835)

(51) Cl.Int./Int.Cl. *H01B 7/28* (2006.01),  
*H01B 7/18* (2006.01)  
 (72) Inventeurs/Inventors:  
VARKEY, JOSEPH P., US;  
SRIDHAR, GARUD, US;  
SILVERMAN, SETH, US;  
BHAVSAR, RASHMI B., US  
 (73) Propriétaire/Owner:  
SCHLUMBERGER CANADA LIMITED, CA  
 (74) Agent: SMART & BIGGAR

(54) Titre : FILS ARMES AMELIORES POUR CABLES ELECTRIQUES  
 (54) Title: ENHANCED ARMOR WIRES FOR ELECTRICAL CABLES



(57) **Abrégé/Abstract:**

Disclosed are electric cables with improved armor wires used with wellbore devices to analyze geologic formations adjacent a wellbore. The cables include at least one insulated conductor, and one or more armor wires surrounding the insulated conductor. The armor wires include a high strength core surrounded by a corrosion resistant alloy clad, where the alloy clad includes such alloys as beryllium-copper based alloys, nickel-chromium based alloys, superaustenitic stainless steel alloys, nickel-cobalt based alloys, nickel-molybdenum-chromium based alloys, and the like. The cables of the invention may be any useful electric cable, including monocables, quadcables, heptacables, quadcables, slickline cables, multiline cables, coaxial cables, or seismic cables. Also disclosed are methods for preparing such cables.

**ABSTRACT**

(00047) Disclosed are electric cables with improved armor wires used with wellbore devices to analyze geologic formations adjacent a wellbore. The cables include at least one insulated conductor, and one or more armor wires surrounding the insulated conductor. The armor wires include a high strength core surrounded by a corrosion resistant alloy clad, where the alloy clad includes such alloys as beryllium-copper based alloys, nickel-chromium based alloys, superaustenitic stainless steel alloys, nickel-cobalt based alloys, nickel-molybdenum-chromium based alloys, and the like. The cables of the invention may be any useful electric cable, including monocables, quadcables, heptacables, quadcables, slickline cables, multiline cables, coaxial cables, or seismic cables. Also disclosed are methods for preparing such cables.

**ENHANCED ARMOR WIRES FOR ELECTRICAL CABLES****BACKGROUND OF THE INVENTION**

(0001) This invention relates to electric cables, and methods of manufacturing and using such cables. In one aspect, the invention relates to electric cables with improved armor wires used with wellbore devices to analyze geologic formations adjacent a wellbore, methods of manufacturing same, as well as uses of such cables.

(0002) Generally, geologic formations within the earth that contain oil and/or petroleum gas have properties that may be linked with the ability of the formations to contain such products. For example, formations that contain oil or petroleum gas have higher electrical resistivity than those that contain water. Formations generally comprising sandstone or limestone may contain oil or petroleum gas. Formations generally comprising shale, which may also encapsulate oil-bearing formations, may have porosities much greater than that of sandstone or limestone, but, because the grain size of shale is very small, it may be very difficult to remove the oil or gas trapped therein. Accordingly, it may be desirable to measure various characteristics of the geologic formations adjacent to a well before completion to help in determining the location of an oil- and/or petroleum gas-bearing formation as well as the amount of oil and/or petroleum gas trapped within the formation.

(0003) Logging tools, which are generally long, pipe-shaped devices may be lowered into the well to measure such characteristics at different depths along the well. These logging tools may include gamma-ray emitters/receivers, caliper devices, resistivity-measuring devices, neutron emitters/receivers, and the like, which are used to sense characteristics of the formations adjacent the well. A wireline cable connects the logging tool with one or more electrical power sources and data analysis equipment at the earth's surface, as well as providing structural support to the

logging tools as they are lowered and raised through the well. Generally, the wireline cable is spooled out of a truck, over a pulley, and down into the well.

**(0004)** Wireline cables are typically formed from a combination of metallic conductors, insulative material, filler materials, jackets, and metallic armor wires. Armor wires typically perform many functions in wireline cables, including protecting the electrical core from the mechanical abuse seen in typical downhole environment, and providing mechanical strength to the cable to carry the load of the tool string and the cable itself.

**(0005)** Armor wire performance is heavily dependent on corrosion protection. Harmful fluids in the downhole environment may cause armor wire corrosion, and once the armor wire begins to rust, strength and pliability may be quickly compromised. Although the cable core may still remain functional, it is not economically feasible to replace the armor wire(s), and the entire cable typically must be discarded.

**(0006)** Conventionally, wellbore electrical cables utilize galvanized steel armor wires (typically plain carbon steels in the range AISI 1065 and 1085), known in the art as Galvanized Improved Plow Steel (GIPS) armor wires, which do provide high strength. Such armor wires are typically constructed of cold-drawn pearlitic steel coated with zinc for moderate corrosion protection. The GIPS armor wires are protected by a zinc hot-dip coating that acts as a sacrificial layer when the wires are exposed to moderate environments.

**(0007)** While zinc protects the steel at moderate conditions and temperatures, it is known that corrosion is readily possible at elevated temperatures and certain aggressive "sour well" downhole conditions. Hence, in such environments the typical useful life of a cable is limited, and the cable may be easily compromised. Also, hot dip galvanization results in a decreased steel strength and increases potential fracture origin sites, which may further contribute to corrosion related GIPS armor wire failure.

79628-240

(0008) Further, during hot-dip galvanization an intermediate zinc-iron alloy layer forms between the steel and zinc. Because steel, zinc-iron alloys, and zinc all have different thermal expansion coefficients, this may lead to formation of cracks in the zinc-iron alloy layer during the post-hot-dip cooling process. These stress-relieving cracks are typically extended during the post-galvanization drawing process. The presence of such fractures during cable processing further decreases the corrosion resistance of cables using such armor wires. Zinc can also flake off during cable manufacturing, leading to significant accumulation of zinc dust in the manufacturing area.

(0009) Commonly, sour well cables constructed completely of corrosion resistant alloys are used in sour well downhole conditions. While such alloys are well suited for forming armor wires used in cables for such wells, it is commonly known that the strength of such alloys is very limited.

(00010) Thus, a need exists for electric cables that are high strength with improved corrosion and abrasion protection, while avoiding cracking and accumulation of zinc dust in the manufacturing environment. An electrical cable that can overcome one or more of the problems detailed above while conducting larger amounts of power with significant data signal transmission capability, would be highly desirable, and the need is met at least in part by the following invention.

79628-240

**BRIEF SUMMARY OF THE INVENTION**

(00010a) According to an aspect of the present invention, there is provided an electric cable comprising at least one insulated conductor and one or more armor wire layers surrounding the insulated conductor, wherein the armor wire layer comprises armor wires comprising a  
5 high strength core and a corrosion resistant alloy clad, and wherein the corrosion resistant alloy clad is the outer layer of the armor wires.

(00011) In one aspect, the invention relates to electric cables with enhanced armor wires used with wellbore devices to analyze geologic formations adjacent a wellbore. The cables include at least one insulated conductor, and one or more armor wire layers surrounding the insulated  
10 conductor. The enhanced design of the armor wires used to form the armor wire layers include a high strength core surrounded by a corrosion resistant alloy clad (outer layer), such as a nickel based alloy, for example. A bonding layer may also be placed between the high strength core and corrosion resistant alloy clad. The electrical cables may include a first armor wire layer surrounding the insulated conductor, and a second armor wire layer served  
15 around the first armor

79628-240

wire layer. The cables of the invention may be useful for a variety of applications including cables in subterranean operations, such as a monocable, a quadcable, a heptacable, slickline cable, multiline cable, a coaxial cable, or a seismic cable.

(00012) Any suitable material to form the high strength core may be used. Materials useful to form the corrosion resistant alloy clad of the armor wires include, by non-limiting example, such alloys as copper-nickel-tin based alloys, beryllium-copper based alloys, nickel-chromium based alloys, superaustenitic stainless steel alloys, nickel-cobalt based alloys and nickel-molybdenum-chromium based alloys, and the like, or any mixtures thereof.

(00013) Insulation materials used to form insulated conductors useful in cables of the invention include, but are not necessarily limited to, polyolefins, polyaryletherether ketone, polyaryl ether ketone, polyphenylene sulfide, modified polyphenylene sulfide, polymers of ethylene-tetrafluoroethylene, polymers of poly(1,4-phenylene), polytetrafluoroethylene, perfluoroalkoxy polymers, fluorinated ethylene propylene, polytetrafluoroethylene-perfluoromethylvinylether polymers, polyamide, polyurethane, thermoplastic polyurethane, chlorinated ethylene propylene, ethylene chloro-trifluoroethylene, and any mixtures thereof.

(00014) Another aspect relates to methods for preparing an electrical cable which include forming the armor wires used to form the armor wire layers, providing at least one insulated conductor, serving a first layer of the armor wires around the insulated conductor, and serving a second layer of the same armor wires around the first layer of the armor wires. In one approach, the enhanced design of the armor wires are prepared by providing a high strength core, bringing the core strength member into contact with at least one sheets of a corrosion resistant alloy clad material, forming the sheet of alloy material around the high strength core, and drawing the combination of the alloy material and core strength member to a final diameter to form the enhanced design of the armor wire. Another approach to preparing the armor wires includes

79628-240

providing a high strength core, extruding an alloy material around the core, and drawing the combination of the alloy material and core strength member to a final diameter to form the armor wire. The preparation of armor wires may also include coating the high strength core with a bonding layer before forming the forming the alloy clad material around the high strength core.

#### **BRIEF DESCRIPTION OF THE DRAWINGS**

(00015) The invention may be understood by reference to the following description taken in conjunction with the accompanying drawings:

(00016) FIG. 1 is a cross-sectional view of a typical prior art cable design.

(00017) FIG. 2 is a stylized cross-sectional representation of an armor wire design useful in some cables of embodiments of the invention.

(00018) FIG. 3 is a cross-sectional representation of a general cable design according to an embodiment of the invention using two layers of armor wires.

(00019) FIG. 4 is a cross-sectional representation of a heptacable design according to an embodiment of the invention, including two layers of armor wires.

(00020) FIG. 5 represents, by stylized cross-section, a monocable design according to an embodiment of the invention.

(00021) FIG. 6 illustrates a method of preparing armor wires useful in cables according to an embodiment of the invention.

(00022) FIG. 7 illustrates another method of preparing some armor wires useful in cables according to an embodiment of the invention.

79628-240

(00023) FIG. 8 illustrates yet another method of preparing some armor wires.

#### **DETAILED DESCRIPTION OF EMBODIMENTS**

(00024) Illustrative embodiments of the invention are described below. In the interest of clarity, not all features of an actual implementation are described in this specification. It will of course be appreciated that in the development of any such actual embodiment, numerous implementation-specific decisions must be made to achieve the developer's specific goals, such as compliance with system related and business related constraints, which will vary from one implementation to another. Moreover, it will be appreciated that such a development effort might be complex and time consuming but would nevertheless be a routine undertaking for those of ordinary skill in the art having the benefit of this disclosure.

(00025) The invention relates to electrical cables and methods of manufacturing the same, as well as uses thereof. In one aspect, the invention relates to an electrical cables used with devices to analyze geologic formations adjacent a wellbore, methods of manufacturing the same, and uses of the cables in seismic and wellbore operations. While this invention and its claims are not bound by any particular mechanism of operation or theory, it has been discovered that using certain alloys to form an alloy clad upon a high strength core in preparing an armor wire, provides electrical cables that have increased corrosion resistance, increased abrasion resistance, which possess high strength properties, while minimizing stress-relieving cracking/fracturing and zinc dust accumulation commonly encountered during cable manufacturing.

(00026) Cable embodiments of the invention generally include at least one insulated conductor, and at least one layer of high strength corrosion resistant armor wires surrounding the insulated conductor(s). Insulated conductors useful in the embodiments of the invention include metallic conductors, or even one or more optical fibers. Such conductors or optical fibers may be encased

in an insulated jacket. Any suitable metallic conductors may be used. Examples of metallic conductors include, but are not necessarily limited to, copper, nickel coated copper, or aluminum. Preferred metallic conductors are copper conductors. While any suitable number of metallic conductors may be used in forming the insulated conductor, preferably from 1 to about 60 metallic conductors are used, more preferably 7, 19, or 37 metallic conductors. Components, such as conductors, armor wires, filler, optical fibers, and the like, used in cables according to the invention may be positioned at zero helix angle or any suitable helix angle relative to the center axis of the cable. Generally, a central insulated conductor is positioned at zero helix angle, while those components surrounding the central insulated conductor are helically positioned around the central insulated conductor at desired helix angles. A pair of layered armor wire layers may be contra-helically wound, or positioned at opposite helix angles.

(00027) Insulating materials useful to form the insulation for the conductors and insulated jackets may be any suitable insulating materials known in the art. Non-limiting examples of insulating materials include polyolefins, polytetrafluoroethylene-perfluoromethylvinylether polymer (MFA), perfluoro-alkoxyalkane polymer (PFA), polytetrafluoroethylene polymers (PTFE), ethylene-tetrafluoroethylene polymers (ETFE), ethylene-propylene copolymers (EPC), poly(4-methyl-1-pentene) (TPX<sup>®</sup> available from Mitsui Chemicals, Inc.), other fluoropolymers, polyaryletherether ketone polymers (PEEK), polyphenylene sulfide polymers (PPS), modified polyphenylene sulfide polymers, polyether ketone polymers (PEK), maleic anhydride modified polymers, perfluoroalkoxy polymers, fluorinated ethylene propylene polymers, polytetrafluoroethylene-perfluoromethylvinylether polymers, polyamide polymers, polyurethane, thermoplastic polyurethane, ethylene chloro-trifluoroethylene polymers (such as Halar<sup>®</sup>), chlorinated ethylene propylene polymers, Parmax<sup>®</sup> SRP polymers (self-reinforcing polymers manufactured by Mississippi Polymer Technologies, Inc based on a substituted poly (1,4-

phenylene) structure where each phenylene ring has a substituent R group derived from a wide variety of organic groups), or the like, and any mixtures thereof.

**(00028)**In some embodiments of the invention, the insulated conductors are stacked dielectric insulated conductors, with electric field suppressing characteristics, such as those used in the cables described in U.S. Patent No. 6,600,108 (Mydur, et al.). Such stacked dielectric insulated conductors generally include a first insulating jacket layer disposed around the metallic conductors wherein the first insulating jacket layer has a first relative permittivity, and, a second insulating jacket layer disposed around the first insulating jacket layer and having a second relative permittivity that is less than the first relative permittivity. The first relative permittivity is within a range of about 2.5 to about 10.0, and the second relative permittivity is within a range of about 1.8 to about 5.0.

**(00029)**Electrical cables according to the invention may be of any practical design. The cables may be wellbore cables, including monocables, coaxial cables, quadcables, heptacables, seismic cables, slickline cables, multi-line cables, and the like. In coaxial cable designs of the invention, a plurality of metallic conductors surround the insulated conductor, and are positioned about the same axis as the insulated conductor. Also, for any cables of the invention, the insulated conductors may further be encased in a tape. All materials, including the tape disposed around the insulated conductors, may be selected so that they will bond chemically and/or mechanically with each other. Cables of the invention may have an outer diameter from about 0.5 mm to about 400 mm, preferably, a diameter from about 1 mm to about 100 mm, more preferably from about 2 mm to about 15 mm.

**(00030)**Referring now to **FIG. 1**, a cross-sectional view of a common electrical cable design. **FIG. 1** depicts a cross-section of a typical armored cable design used for downhole applications. The cable **100** includes a central conductor bundle **102** having multiple conductors and an outer

polymeric insulating material. The cable **100** further includes a plurality of outer conductor bundles **104**, each having several metallic conductors **106** (only one indicated), and a polymeric insulating material **108** surrounding the outer metallic conductors **106**. Preferably, the metallic conductor **106** may be a copper conductor. The central conductor bundle **102** of a typical prior art cables, although need not be, is typically the same design as the outer conductor bundles **104**. An optional tape and/or tape jacket **110** made of a material that may be either electrically conductive or electrically non-conductive and that is capable of withstanding high temperatures encircles the outer conductor bundles **104**. The volume within the tape and/or tape jacket **110** not taken by the central conductor bundle **102** and the outer conductors **104** is filled with a filler **112**, which may be made of either an electrically conductive or an electrically non-conductive material. A first armor layer **114** and a second armor layer **116**, generally made of a high tensile strength galvanized improved plow steel (GIPS) armor wires, surround and protect the tape and/or tape jacket **110**, the filler **112**, the outer conductor bundles **104**, and the central conductor bundle **102**.

(00031) Armor wires useful for cable embodiments of the invention, have bright, drawn high strength steel wires (of appropriate carbon content and strength for wireline use) placed at the core of the armor wires. An alloy with resistance to corrosion is then clad over the core. The corrosion resistant alloy layer may be clad over the high strength core by extrusion or by forming over the steel wire. The corrosion resistant clad may be from about 50 microns to about 600 microns in thickness. The material used for the corrosion resistant clad may be any suitable alloy that provides sufficient corrosion resistance and abrasion resistance when used as a clad. The alloys used to form the clad may also have tribological properties adequate to improve the abrasion resistance and lubricating of interacting surfaces in relative motion, or improved corrosion resistant properties that minimize gradual wearing by chemical action, or even both properties.

**(00032)** While any suitable alloy may be used as a corrosion resistant alloy clad to form the armor wires according to the invention, some examples include, but are not necessarily limited to: beryllium-copper based alloys; nickel-chromium based alloys (such as Inconel® available from Reade Advanced Materials, Providence, Rhode Island USA 02915-0039); superaustenitic stainless steel alloys (such as 20Mo6® of Carpenter Technology Corp., Wyomissing, PA 19610-1339 U.S.A., INCOLOY® alloy 27-7MO and INCOLOY® alloy 25-6MO from Special Metals Corporation of New Hartford, New York, U.S.A., or Sandvik 13RM19 from Sandvik Materials Technology of Clarks Summit, Pa. 18411, U.S.A.); nickel-cobalt based alloys (such as MP35N from Alloy Wire International, Warwick, Rhode Island, 02886 U.S.A.); copper-nickel-tin based alloys (such as ToughMet® available from Brush Wellman, Fairfield, New Jersey, USA); or, nickel-molybdenum-chromium based alloys (such as HASTELLOY® C276 from Alloy Wire International). The corrosion resistant alloy clad may also be an alloy comprising nickel in an amount from about 10% to about 60% by weight of total alloy weight, chromium in an amount from about 15% to about 30% by weight of total alloy weight, molybdenum in an amount from about 2% to about 20% by weight of total alloy weight, cobalt in an amount up to about 50% by weight of total alloy weight, as well as relatively minor amounts of other elements such as carbon, nitrogen, titanium, vanadium, or even iron. The preferred alloys are nickel-chromium based alloys, and nickel-cobalt based alloys.

**(00033)** Cables according to the invention include at least one layer of armor wires surrounding the insulated conductor. The armor wires used in cables of the invention, comprising a high strength core and an corrosion resistant alloy clad may be used alone, or may be combined with other types armor wires, such as galvanized improved plow steel wires, to form the armor wire layers. Preferably, two layers of armor wires are used to form preferred electrical cables of the invention.

**(00034)** FIG. 2 is a stylized cross-sectional representation of an enhanced design of the armor wire useful in some cables of the invention. The armor wire **200** includes a high strength core **202**, surrounded by a corrosion resistant alloy clad **206**. An optional bonding layer **204** may be placed between the core **202** and alloy clad **206**. The core **202** may be generally made of any high tensile strength material such as, by non-limiting example, steel. Examples of suitable steels which may be used as core strength members include, but are not necessarily limited to AISI (American Iron and Steel Institute) 1070, AISI 1086, or AISI 1095 steel grades, tire cords, any high strength steel wires with strength greater than 2900 mPa, and the like. The core strength member **202** can include steel core for high strength, or even plated or coated wires. When used, the bonding layer **204** may be any material useful in promoting a strong bond between the high strength core **202** and corrosion resistant alloy clad **206**. Preferably, when used, a layer of brass may be applied through a hot-dip or electrolytic deposition process to form the bonding layer **204**.

**(00035)** Referring now to FIG. 3, a cross-sectional representation of a general cable design according to the invention which incorporates two layers of armor wires. The cable **300** includes at least one insulated conductor **302** and two layers of armor wires, **304** and **306**. The armor wire layers, **304** and **306**, surrounding the insulated conductor(s) **302** include armor wires, such as armor wire **200** in FIG. 2, comprising a high strength core and a corrosion resistant alloy clad. Optionally, in the interstitial spaces **308**, formed between armor wires, as well as formed between armor wires and insulated conductor(s) **302**, a polymeric material may be disposed.

**(00036)** Polymeric materials disposed in the interstitial spaces **308** may be any suitable material. Some useful polymeric materials include, by nonlimiting example, polyolefins (such as EPC or polypropylene), other polyolefins, polyaryletherether ketone (PEEK), polyaryl ether ketone (PEK), polyphenylene sulfide (PPS), modified polyphenylene sulfide, polymers of ethylene-tetrafluoroethylene (ETFE), polymers of poly(1,4-phenylene), polytetrafluoroethylene (PTFE),

perfluoroalkoxy (PFA) polymers, fluorinated ethylene propylene (FEP) polymers, polytetrafluoroethylene-perfluoromethylvinylether (MFA) polymers, Parmax®, and any mixtures thereof. Preferred polymeric materials are ethylene-tetrafluoroethylene polymers, perfluoroalkoxy polymers, fluorinated ethylene propylene polymers, and polytetrafluoroethylene-perfluoromethylvinylether polymers. The polymeric materials may be disposed contiguously from the insulated conductor to the outermost layer of armor wires, or may even extend beyond the outer periphery thus forming a polymeric jacket that completely encases the armor wires.

**(00037)** A protective polymeric coating may be applied to strands of armor wire for additional protection, or even to promote bonding between the armor wire and the polymeric material disposed in the interstitial spaces. As used herein, the term bonding is meant to include chemical bonding, mechanical bonding, or any combination thereof. Examples of coating materials which may be used include, but are not necessarily limited to, fluoropolymers, fluorinated ethylene propylene (FEP) polymers, ethylene-tetrafluoroethylene polymers (Tefzel®), perfluoroalkoxyalkane polymer (PFA), polytetrafluoroethylene polymer (PTFE), polytetrafluoroethylene-perfluoromethylvinylether polymer (MFA), polyaryletherether ketone polymer (PEEK), or polyether ketone polymer (PEK) with fluoropolymer combination, polyphenylene sulfide polymer (PPS), PPS and PTFE combination, latex or rubber coatings, and the like. Each armor wire may also be plated with materials for corrosion protection or even to promote bonding between the armor wire and polymeric material. Nonlimiting examples of suitable plating materials include copper alloys, and the like. Plated armor wires may even cords such as tire cords. While any effective thickness of plating or coating material may be used, a thickness from about 10 microns to about 100 microns is preferred.

**(00038)** FIG. 4 is a cross-sectional representation of a heptacable design according to the invention, including two layers of armor wires. The cable 400 includes two layers of armor wires,

**402** and **404**, surrounding a tape and/or tape jacket **406**. The armor wire layers, **402** and **404**, include armor wires, such as armor wire **200** in **FIG. 2**, comprising a high strength core and a corrosion resistant alloy clad. The interstitial space within the tape and/or tape jacket **406** comprises a central insulated conductor **408** and six outer insulated conductors **410** (only one indicated). The interstitial space within the tape and/or tape jacket **406**, not occupied by the central insulated conductor **408** and six outer insulated conductors **410** may be filled with a suitable filler material, which may be made of either an electrically conductive or an electrically non-conductive material. The central insulated conductor **408** and six outer insulated conductors **410**, each have a plurality of conductors **412** (only one indicated), and insulating material **414** surrounding the conductors **412**. Preferably, the conductor **412** is a copper conductor. Optionally, a polymeric material may be disposed in the interstitial spaces **416**, formed between armor wires, as well as formed between armor wires and tape jacket **406**.

**(00039)FIG. 5** represents, by stylized cross-section, a monocable design according to the invention. The cable **500** includes two layers of armor wires, **502** and **504**, surrounding a tape and/or tape jacket **506**. The armor wire layers, **502** and **504**, include armor wires, such as armor wire **200** in **FIG. 2**, comprising a high strength core and a corrosion resistant alloy clad. The central conductor **508** and six outer conductors **510** (only one indicated) are surrounded by tape jacket **506** and layers of armor wires **502** and **504**. Preferably, the conductors **508** and **510** are copper conductors. The interstitial space formed between the tape jacket **506** and six outer conductors **510**, as well as interstitial spaces formed between the six outer conductors **510** and central conductor **508** the may be filled with an insulating material **512** to form an insulated conductor. Optionally, a polymeric material may be disposed in the interstitial spaces **516**, formed between armor wires, as well as formed between armor wires and tape jacket **506**.

**(00040)FIG. 6** illustrates a method of preparing some armor wires useful in cables according to the invention. Accordingly, a high strength core **A** is provided. At point **602**, the core **A** may optionally be coated with a bonding layer **B**, such as brass using a hot dip or electrolytic deposition process. At point **604** the optional bonding layer coated core **A** is brought into contact with a sheet of corrosion resistant alloy material **C**, such as, by nonlimiting example, Inconel® nickel-chromium based alloy. The alloy material **C** is used to prepare the corrosion resistant alloy clad. At points **606**, **608**, and **610**, the alloy material is formed around the optional bonding layer core **A**, using, for example, rollers. Such forming of the alloy material is done at temperatures between ambient temperature and about 850° C. Additionally, the optional bonding layer **B** may flow and to sufficiently provide a slipping interface between the high strength core **A** and the corrosion resistant alloy clad comprised of alloy material **C**. At point **612**, the wire is drawn down to final diameter to form the armor wire **D**. The drawn thicknesses of the optional bonding layer coated core **A** alloy clad **C** may be proportional to the pre-drawn thickness.

**(00041)FIG. 7** illustrates another method of preparing armor wires. According to this next method, a high strength core **A** is provided, and at point **702**, the high strength core **A** is optionally coated with a bonding layer **B**. At point **704** the optional bonding layer coated core **A** is brought into contact with two separate sheets of corrosion resistant alloy material, **D** and **E**, to form the corrosion resistant alloy clad. At points **706** and **708**, the sheets of alloy material are formed around the optional bonding layer coated core **A**. At point **710**, the wire is drawn down to final diameter to form the armor wire **F**.

**(00042)FIG. 8** illustrates yet another method of preparing armor wires, an extrusion and drawing method. Accordingly, a high strength core **A** is provided, and at point **802**, and corrosion resistant alloy clad **B** is extruded over core **A**. The material forming the corrosion resistant alloy clad **B** may be hot or cold extruded onto the core **A**. At **804**, the wire is drawn down to final diameter to

form the armor wire C. Further, the high strength core A may be optionally coated with a bonding layer prior to extruding the corrosion resistant alloy clad B.

**(00043)** The materials forming the insulating layers and the polymeric materials used in the cables according to the invention may further include a fluoropolymer additive, or fluoropolymer additives, in the material admixture to form the cable. Such additive(s) may be useful to produce long cable lengths of high quality at high manufacturing speeds. Suitable fluoropolymer additives include, but are not necessarily limited to, polytetrafluoroethylene, perfluoroalkoxy polymer, ethylene tetrafluoroethylene copolymer, fluorinated ethylene propylene, perfluorinated poly(ethylene-propylene), and any mixture thereof. The fluoropolymers may also be copolymers of tetrafluoroethylene and ethylene and optionally a third comonomer, copolymers of tetrafluoroethylene and vinylidene fluoride and optionally a third comonomer, copolymers of chlorotrifluoroethylene and ethylene and optionally a third comonomer, copolymers of hexafluoropropylene and ethylene and optionally third comonomer, and copolymers of hexafluoropropylene and vinylidene fluoride and optionally a third comonomer. The fluoropolymer additive should have a melting peak temperature below the extrusion processing temperature, and preferably in the range from about 200°C to about 350°C. To prepare the admixture, the fluoropolymer additive is mixed with the insulating jacket or polymeric material. The fluoropolymer additive may be incorporated into the admixture in the amount of about 5% or less by weight based upon total weight of admixture, preferably about 1% by weight based or less based upon total weight of admixture, more preferably about 0.75% or less based upon total weight of admixture.

**(00044)** Cables of the invention may include armor wires employed as electrical current return wires which provide paths to ground for downhole equipment or tools. The invention enables the use of armor wires for current return while minimizing electric shock hazard. In some

79628-240

embodiments, a polymeric material isolates at least one armor wire in the first layer of armor wires thus enabling their use as electric current return wires.

**(00045)** The present invention is not limited, however, to cables having only metallic conductors. Optical fibers may be used in order to transmit optical data signals to and from the device or devices attached thereto, which may result in higher transmission speeds, lower data loss, and higher bandwidth.

**(00046)** The particular embodiments disclosed above are illustrative only, as the invention may be modified and practiced in different but equivalent manners apparent to those skilled in the art having the benefit of the teachings herein. Furthermore, no limitations are intended to the details of construction or design herein shown, other than as described in the claims below. It is therefore evident that the particular embodiments disclosed above may be altered or modified and all such variations are considered within the scope of the invention. In particular, every range of values (of the form, "from about a to about b," or, equivalently, "from approximately a to b," or, equivalently, "from approximately a-b") disclosed herein is to be understood as referring to the power set (the set of all subsets) of the respective range of values. Accordingly, the protection sought herein is as set forth in the claims below.

**CLAIMS**

What is claimed is:

1. An electric cable comprising at least one insulated conductor and one or more armor wire layers surrounding the insulated conductor, wherein the armor wire layer comprises armor wires comprising a high strength core and a corrosion resistant alloy clad, and wherein the corrosion resistant alloy clad is the outer layer of the armor wires.
2. A cable according to claim 1 wherein the insulated conductor comprises at least one electrical conductor encased in an insulating material.
3. A cable according to claim 1 where a bonding layer is placed between the high strength core and corrosion resistant alloy clad.
4. A cable according to claim 3 wherein the bonding layer comprises brass.
5. A cable according to claim 1 comprising a first armor wire layer surrounding the insulated conductor and a second armor wire layer served around the first armor wire layer.
6. A cable according to claim 1 further comprising a polymeric material disposed in interstitial spaces formed between the armor wires, as well as formed between the armor wires and insulated conductor.
7. A cable according to claim 2 wherein the insulation material is selected from the group consisting of polyolefins, polyaryletherether ketone, polyaryl ether ketone, polyphenylene sulfide, modified polyphenylene sulfide, polymers of ethylene-tetrafluoroethylene, polymers of poly(1,4-phenylene), polytetrafluoroethylene, perfluoroalkoxy polymers, fluorinated ethylene propylene, polytetrafluoroethylene-perfluoromethylvinylether polymers, polyamide, polyurethane, thermoplastic polyurethane, chlorinated ethylene propylene, ethylene chloro-trifluoroethylene, and any mixtures thereof.

8. A cable according to claim 1 wherein the high strength core is steel and the corrosion resistant alloy clad is an alloy comprising nickel in an amount from about 10% to about 60% by weight of total alloy weight, chromium in an amount from about 15% to about 30% by weight of total alloy weight, molybdenum in an amount from about 2% to about 20% by weight of total alloy weight, and cobalt in an amount up to about 50% by weight of total alloy weight.

9. A cable according to claim 1 wherein the corrosion resistant alloy clad comprises an alloy selected from the group consisting of beryllium-copper based alloys, copper-nickel-tin based alloys, superaustenitic stainless steel alloys, nickel-cobalt based alloys, nickel-chromium based alloys, nickel-molybdenum-chromium based alloys, and any mixtures thereof.

10. A cable according to claim 1 wherein the corrosion resistant alloy clad comprises a nickel-chromium based alloy or a nickel-cobalt based alloy.

11. A cable according to claim 1 wherein the high strength core is steel of strength greater than about 2900 mPa and the corrosion resistant alloy clad comprises a nickel-chromium based alloy.

12. A cable according to claim 2 wherein the insulating material comprises:

(a) a first insulating jacket layer disposed around the metallic conductors wherein the first insulating jacket layer has a first relative permittivity; and

(b) a second insulating jacket layer disposed around the first insulating jacket layer and having a second relative permittivity that is less than the first relative permittivity;

wherein the first relative permittivity is within a range of about 2.5 to about 10.0, and wherein the second relative permittivity is within a range of about 1.8 to about 5.0.

13. A cable according to claim 1 which has an outer diameter from about 0.5 mm to about 400 mm.

14. A cable according to claim 1 wherein the cable is a seismic cable, or a wellbore cable selected from the group consisting of monocable, a quadcable, a heptacable, a quadcable, slickline cable, multiline cable, and a coaxial cable.

15. A wellbore electrical cable according to claim 1 wherein the at least one insulated conductor comprises seven metallic conductors encased in an insulating material, a first layer of armor wires surrounds the insulated conductor, and a second layer of armor wires surrounds the first layer of armor wires.

16. A wellbore electrical cable according to claim 15 comprising seven insulated conductors in a heptacable design.

17. An electric cable according to claim 1 wherein the corrosion resistant alloy clad is extruded over the high strength core, and the clad and core are drawn to prepare the armor wires.

18. An electric cable according to claim 1 wherein the corrosion resistant alloy clad is at least one sheet of corrosion resistant alloy formed over the high strength core, and the clad and core are drawn to prepare the armor wires.

Smart & Biggar  
Ottawa, Canada  
Patent Agents

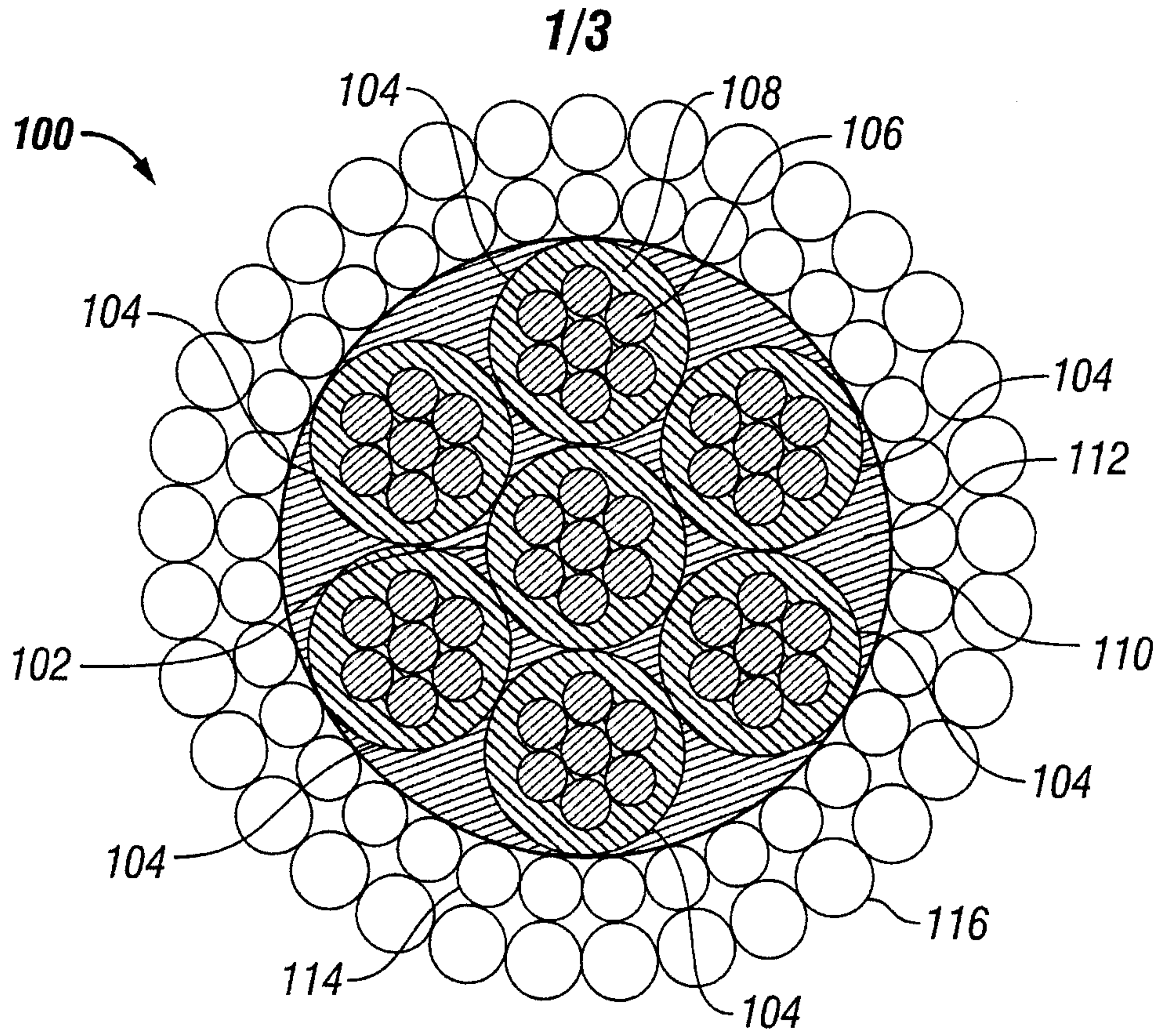

**FIG. 1**  
**(Prior Art)**

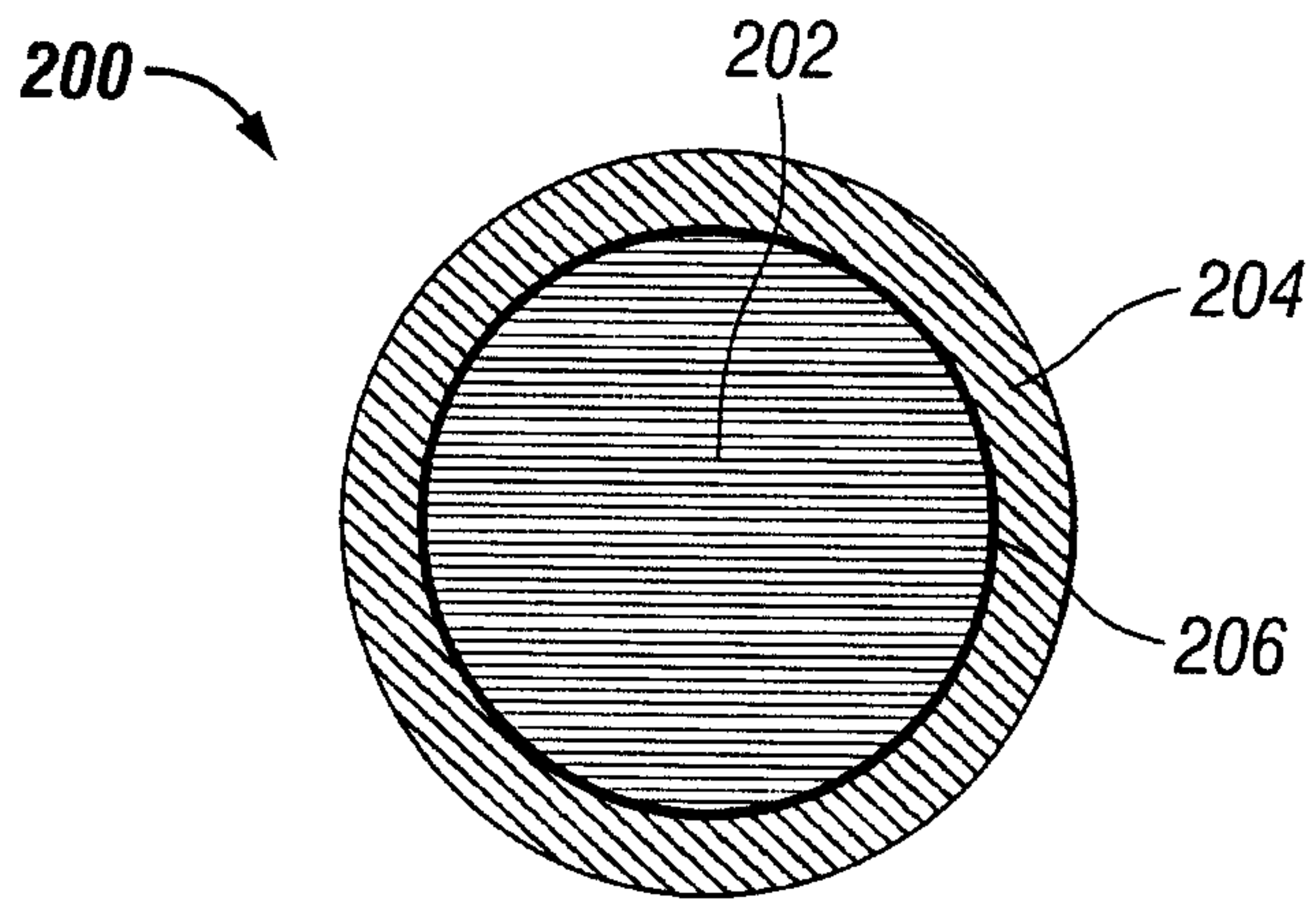

**FIG. 2**

2/3

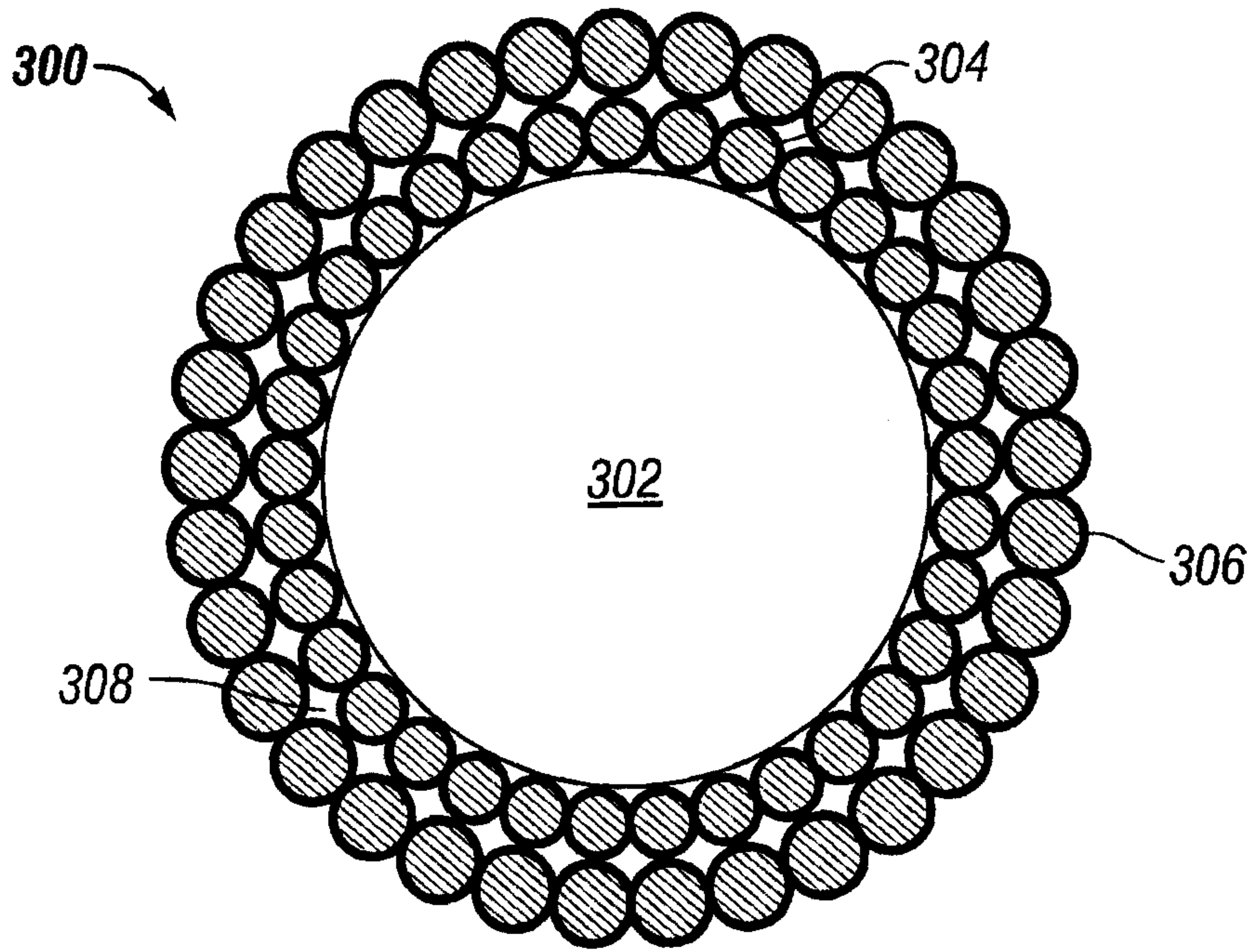

FIG. 3

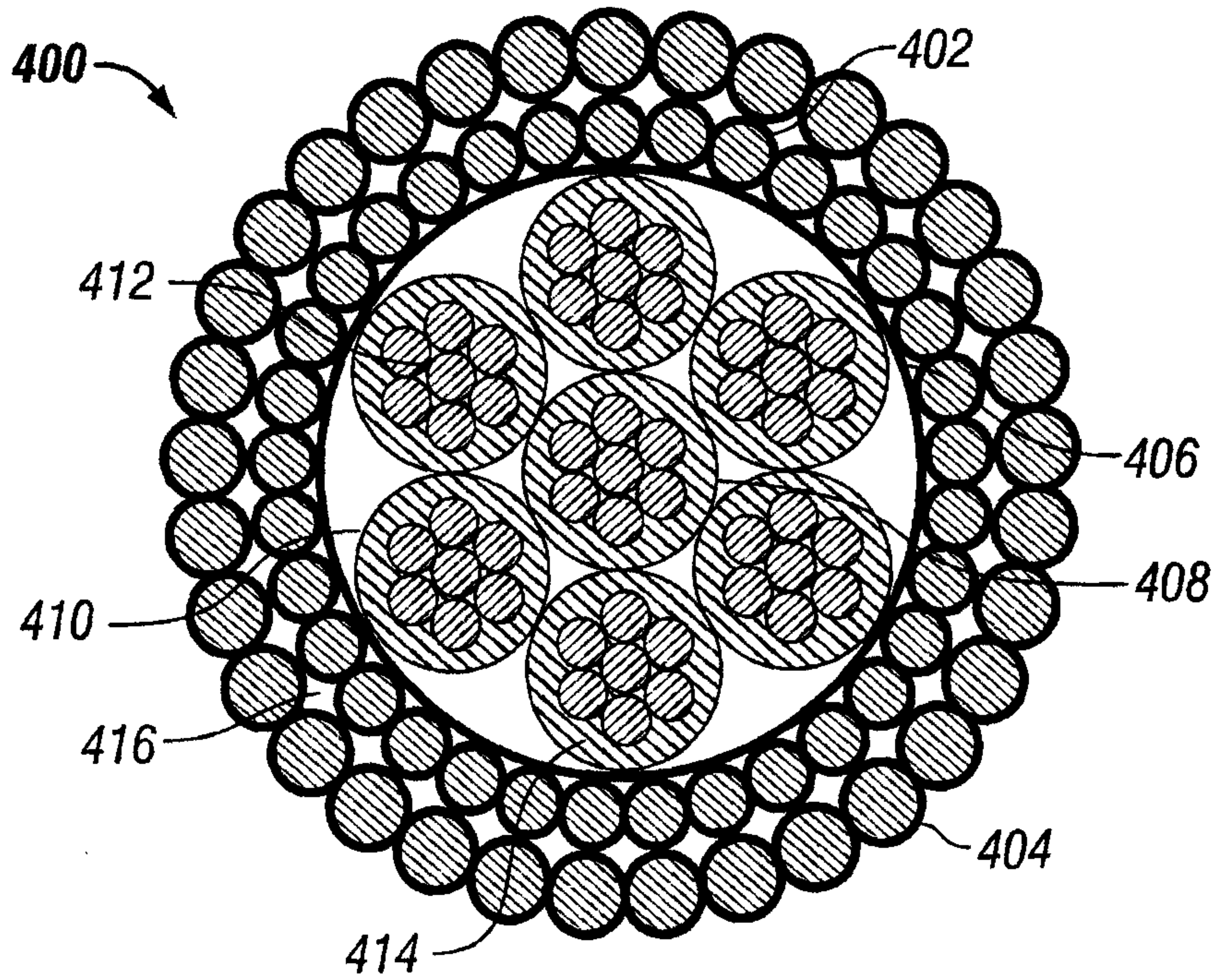

FIG. 4

3/3

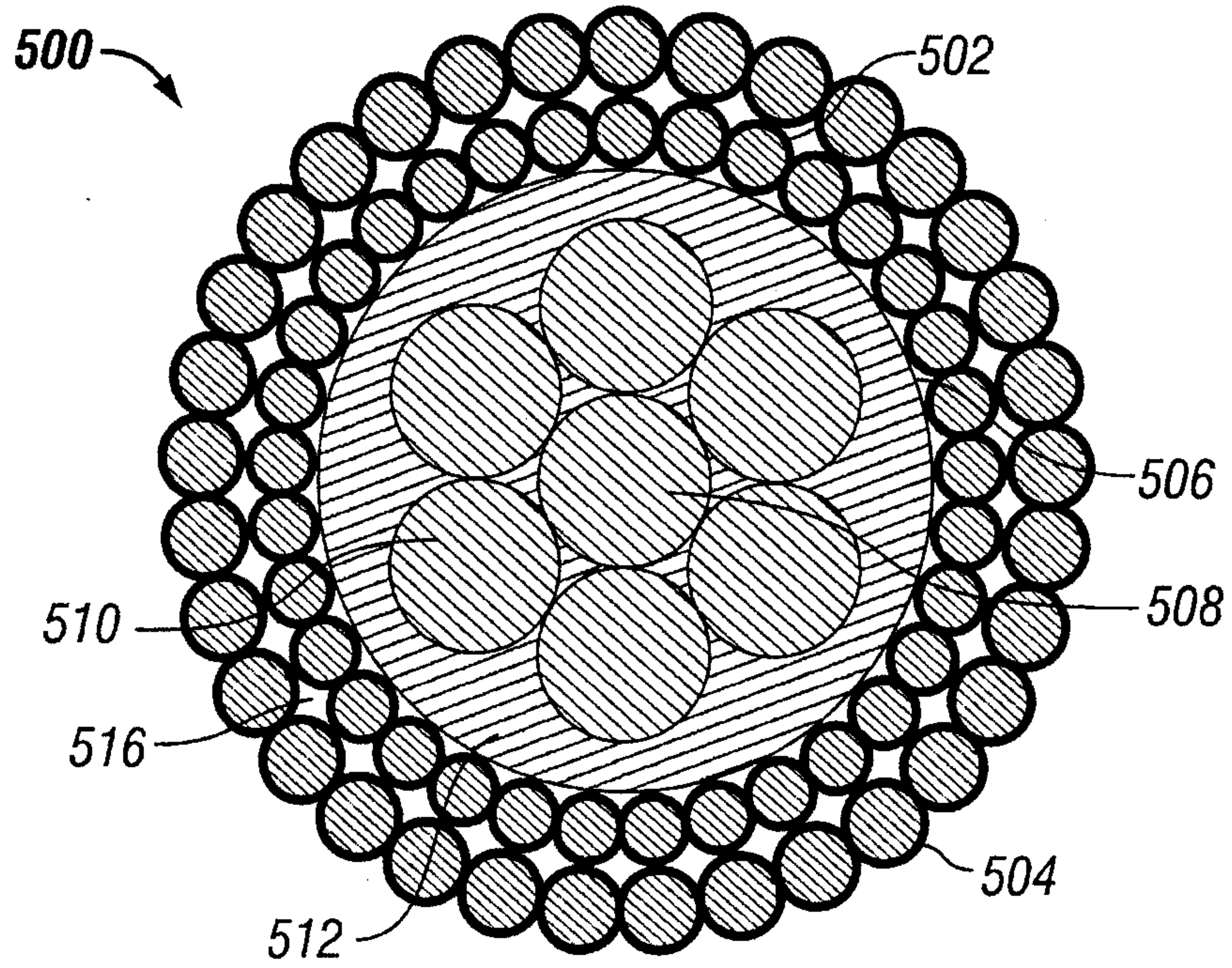

FIG. 5

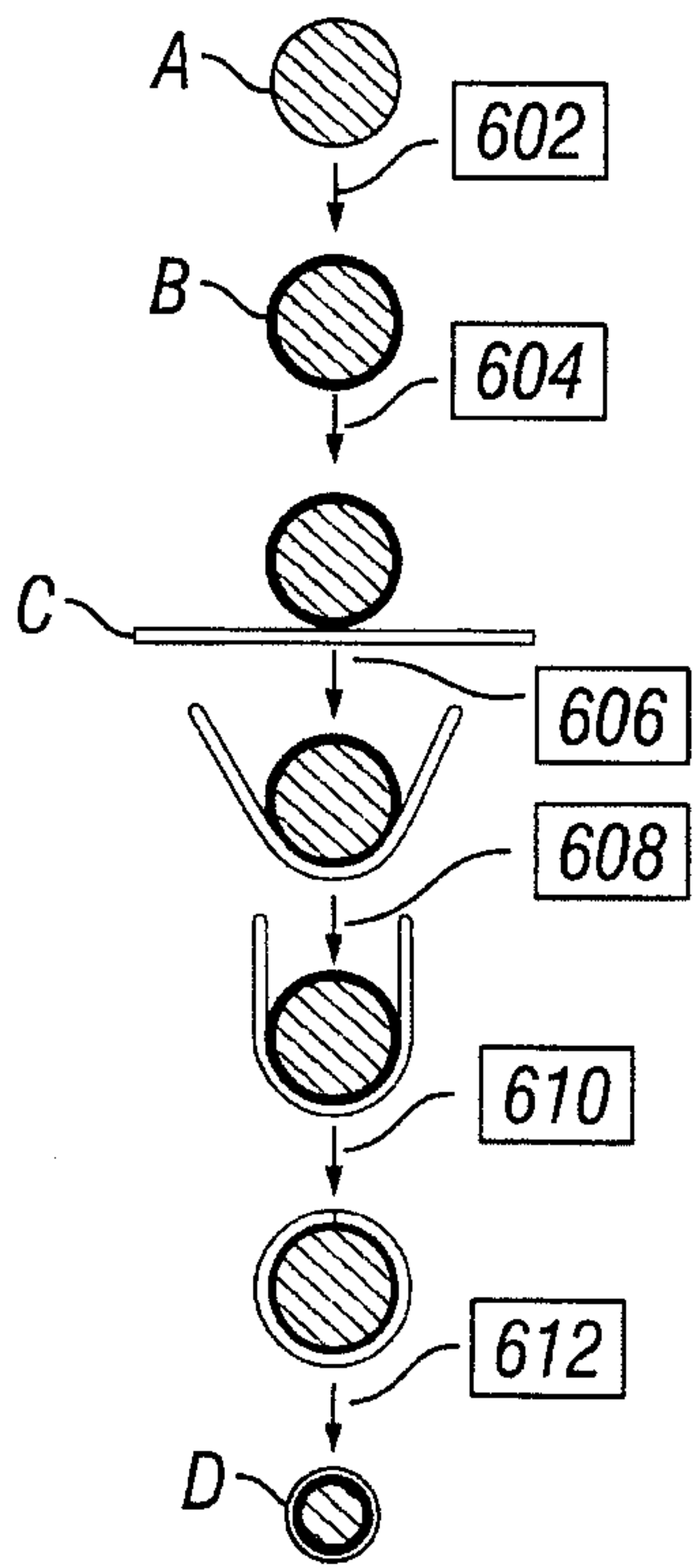

FIG. 6

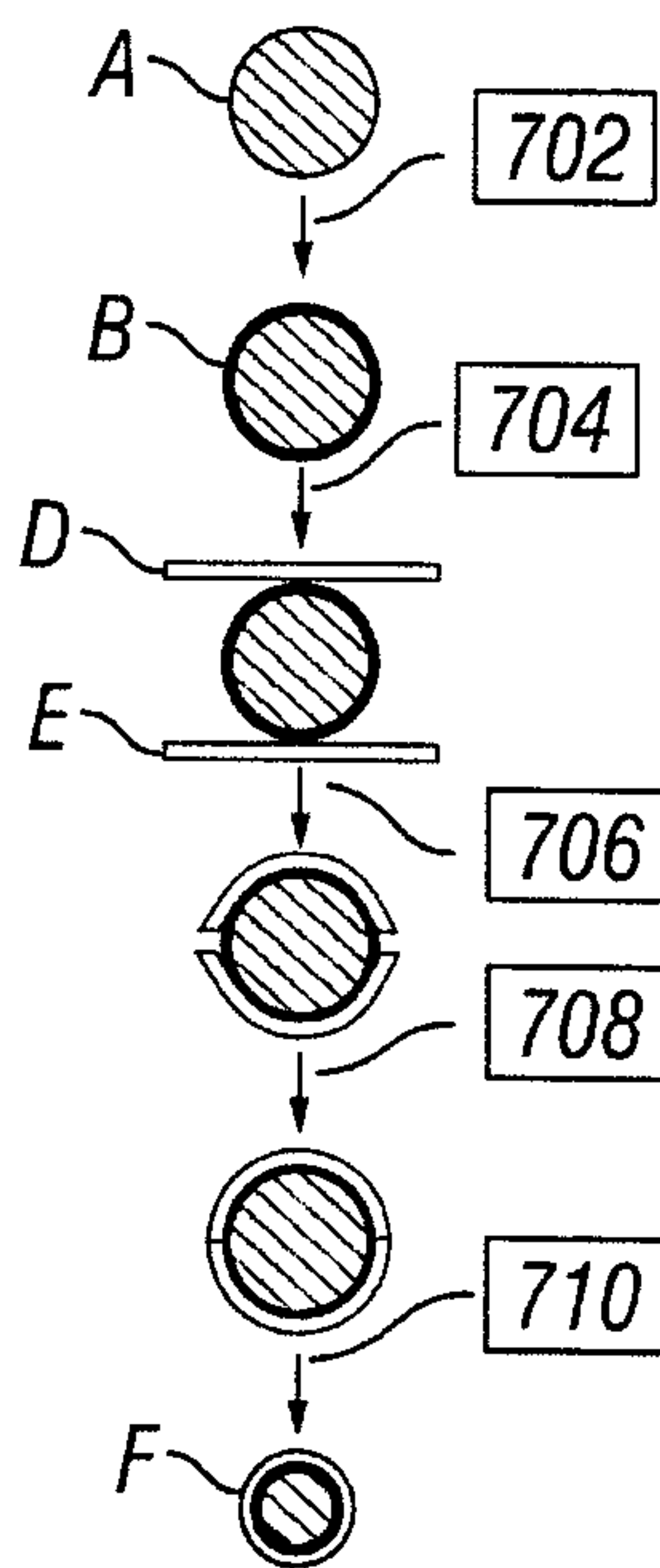

FIG. 7

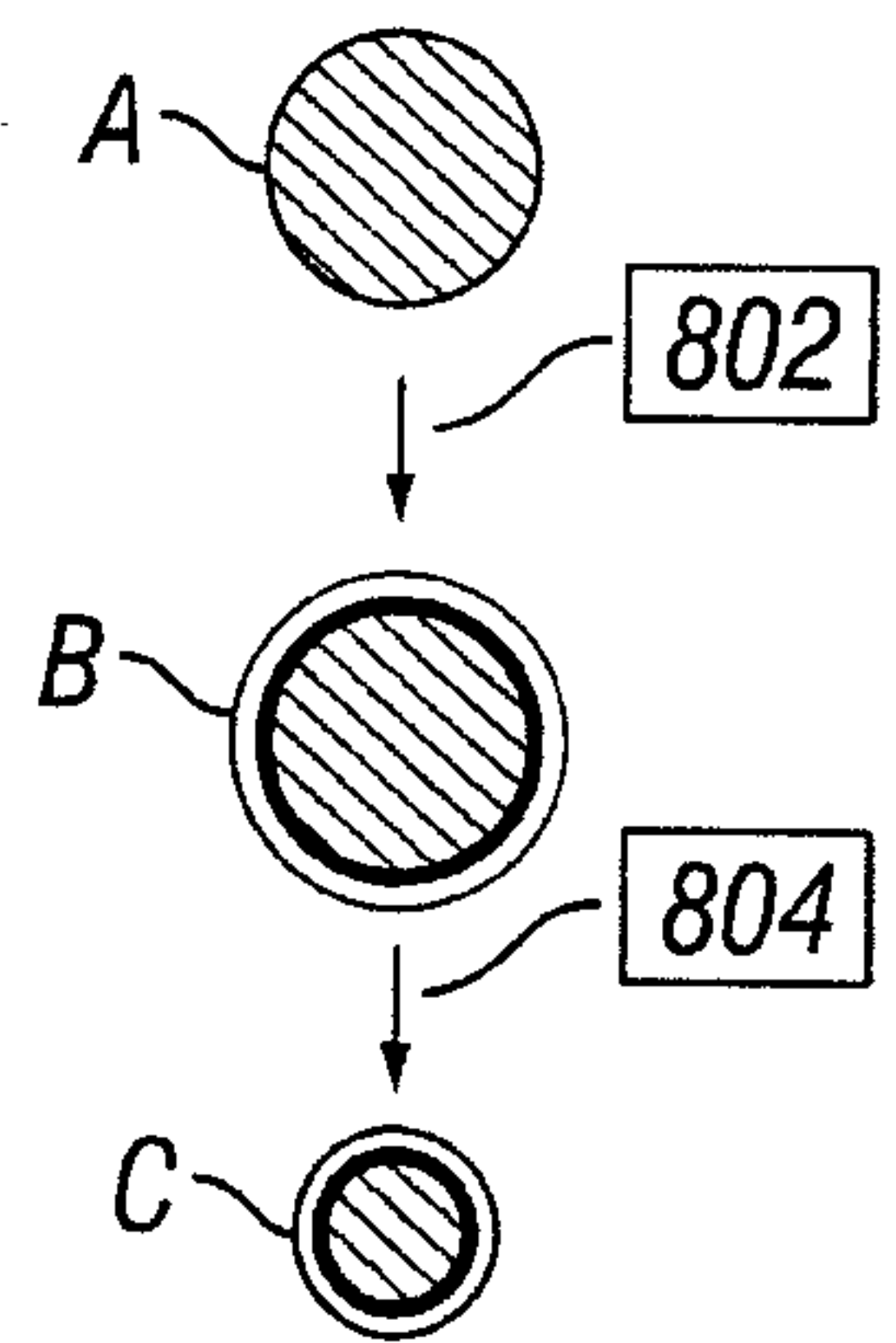

FIG. 8

