

Nov. 5, 1968

J. K. MILES ET AL

3,408,672

SHOE BUFFER

Filed Sept. 21, 1967

3 Sheets-Sheet 1

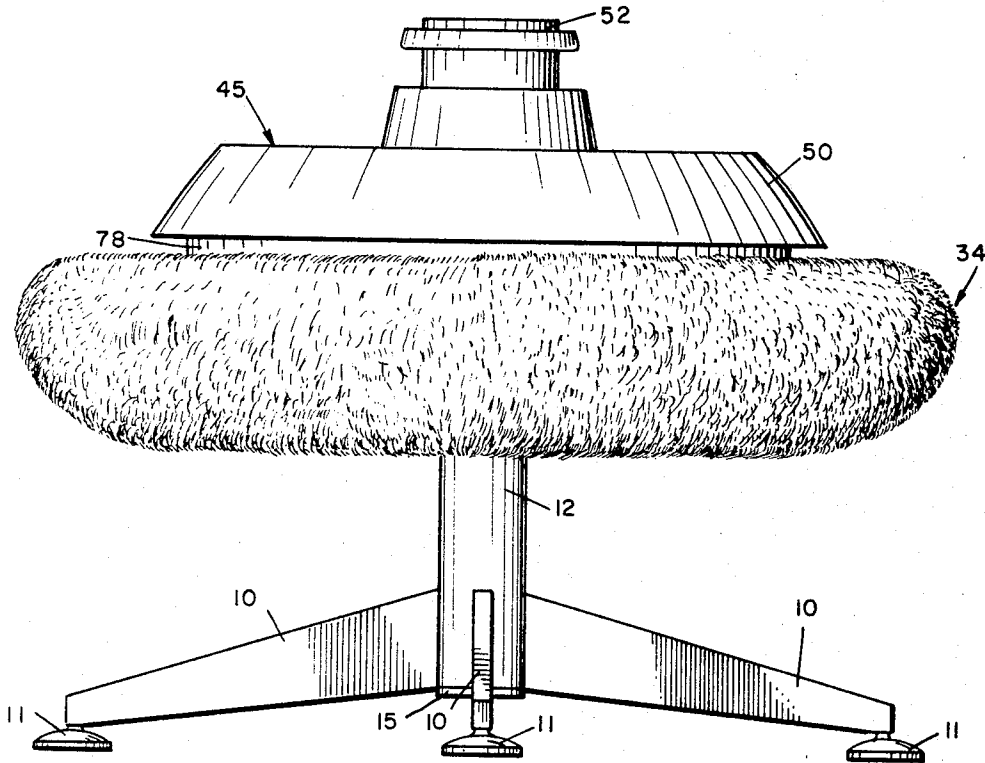

Fig. 1

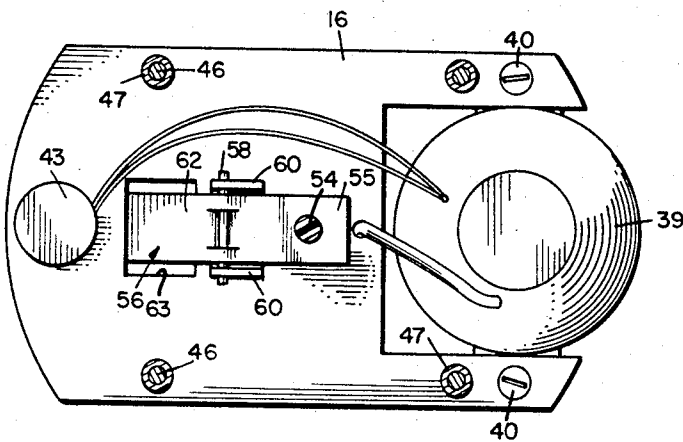

Fig. 4

INVENTORS
JOHN K. MILES
JOHN R. DAVIS
BY
Trade Jones & Hardy
ATTORNEYS

Nov. 5, 1968

J. K. MILES ET AL

3,408,672

SHOE BUFFER

Filed Sept. 21, 1967

3 Sheets-Sheet 2

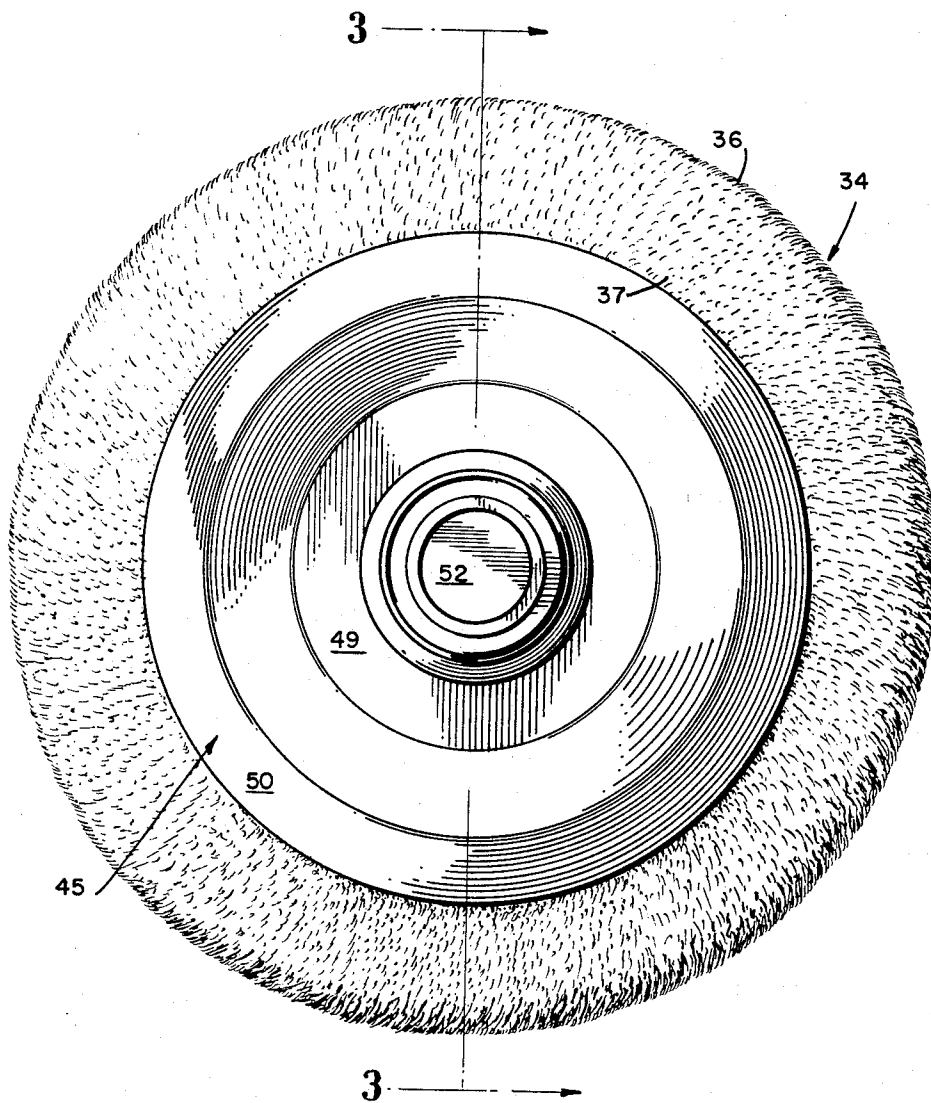

Fig. 2

INVENTORS
JOHN K. MILES
JOHN R. DAVIS

BY

Tracy Jenkins & Hanley
ATTORNEYS

1

2

3,408,672

SHOE BUFFER

John K. Miles and John R. Davis, Columbus, Ind., assignors to Arvin Industries, Inc., Columbus, Ind., a corporation of Indiana

Filed Sept. 21, 1967, Ser. No. 669,441

12 Claims. (Cl. 15-97)

ABSTRACT OF THE DISCLOSURE

A shoe buffing apparatus comprising a floor-engageable base having a vertically extending post mounted thereon. An annular frame having a buffing pad mounted thereon is rotatably mounted on said post. Said frame is rotatably driven for rotating the buffing pad by a motor operatively supported from said post and actuated by switch means mounted on a cover extending over said motor and frame.

Summary of the invention

In accordance with one form of the invention, there is provided a floor-engageable base having a vertically extending post connected thereto. A mounting plate is connected to said post and supports a motor which drives an annular frame rotatably carried on said post below said plate. A buffing pad is removably mounted on said frame for rotation with said frame to provide the desired buffing action.

A cover mounted on said mounting plate extends over said motor and frame. Conveniently, said cover supports an actuator for the switching means for actuating said motor. Mounted on the rotatable frame is an apertured shield which projects upwardly toward said cover to prevent objects from entering the space between said cover and frame while preventing said motor from becoming overheated.

Brief description of the drawings

The accompanying drawings illustrate the invention. In such drawings:

FIG. 1 is a side elevation of a shoe buffer embodying our invention;

FIG. 2 is a top plan view of the buffer shown in FIG. 1;

FIG. 3 is a vertical section taken on the line 3-3 of FIG. 2; and

FIG. 4 is a horizontal section taken on the line 4-4 of FIG. 3.

Detailed description of the preferred embodiment

As shown, our shoe buffer is supported on a floor-engageable base comprising a plurality of legs 10 having downwardly projecting feet 11 at their outer ends. The inner ends of said legs are connected to a hollow vertical post 12 whose lower end is disposed in spaced relation to the floor. A through bolt 14 extends the length of the post with its head bearing against a cap 15 seated against the lower end of said post and its upper end projecting through a mounting plate 16 for connection to a nut 18. In this manner, the plate 16 which projects horizontally outwardly from the post 12 is fixedly connected to the upper end of said post.

An annular frame is rotatably mounted on the post 12 below plate 16. As shown in FIG. 3, said frame comprises a hub 20 carried on the post 12 and connected to an annular outwardly projecting web 22. The hub 20 has an axially extending section 23 provided with bearings 24 and 25 rotatably carried against the outer face of the post. In order to support the frame in a fixed vertical position on the post, a bracket 26 is fixedly mounted on said post in engagement with bearing 24 and a washer 27 is interposed between bearing 25 and the mounting plate 16. The hub

section 23 terminates at its lower end in an outwardly projecting leg 28 connected, as by screws 29, to the frame web 22. As shown in FIG. 3, the web 22 projects horizontally outwardly from the leg 28 and has an annular upwardly directed offset 30 formed therein intermediate its length. Said web projects generally horizontally outwardly from its offset 30 and has its outer margin curved upwardly at 32.

The frame has mounted thereon an annular buffing pad 34 formed from any desired material, such as for example, a tufted material. As shown, said pad extends outwardly from the web offset 30 with its lower inner portion 35 disposed against the lower face of said web, its intermediate portion 36 extending vertically upwardly against the curved outer web margin 32, and its upper portion 37 extending horizontally inwardly from the web margin. An elastic band 38 is sewn into the edge of the pad portion 37 to releasably retain the pad on the web for rotation therewith. Thus, upon rotation of the web 22, the pad portion 35 provides an annular horizontally oriented buffing surface and the intermediate pad portion 36 provides an annular vertically oriented buffing surface.

The frame is rotatably driven by a motor 39 bolted, as at 40, onto the plate 16. Said motor projects downwardly from said plate and has mounted on its drive shaft at its lower end a gear 41 whose teeth are in mesh with a set of circumferential gear teeth 42 formed on the hub leg 28. As will become more apparent hereinafter, operation of the motor 39 is controlled by a switch 43 mounted in an opening in the plate 16 and connected through the motor to a suitable power source by leads 44. Conveniently, the leads 44 can project through openings in the plate 16, cap 15 and post 12 for connection to said power source to thus prevent them from becoming entangled in any of the rotating members.

As shown in FIG. 1, an annular cover 45 is mounted on the upper face of the plate 16 in vertically spaced relation thereto by a plurality of bolts 46 extending through spacers 47 interposed between said cover and plate. Conveniently, the inner margin of the cover is recessed, as at 48, and a decorative ring 48 overlays said recessed inner margin to hide the bolts 46. As shown, the cover extends radially outwardly over the motor 39 and terminates at its outer margin in a downwardly projecting flange 50 whose lower edge is disposed above and adjacent to the upper pad portion 37.

Actuation of switch 43 for controlling the drive motor 39 is controlled by an upwardly projecting switch actuator 52 slidably carried in the central opening of the cover 45. A stud 54 projects downwardly from the bottom face of the actuator into engagement with the upwardly presented face of the upper horizontal arm 55 of a switch link 56 swingably mounted on a pin 58 carried in a pair of ears 60 projecting upwardly from the plate 16. As shown in FIGS. 3 and 4, link 56 has a downwardly angled intermediate stretch 62 projecting through an opening 63 in plate 16 to interconnect the upper horizontal arm 55 to a lower horizontal arm 64 disposed below said plate in alignment with switch 43. The upper face of link arm 64 is in abutting engagement with a downwardly biased plunger 67 on switch 43 below the plate 16. Thus, the plunger 67 urges the link 56 to swing about the axis of pin 58 in a clockwise direction as viewed in FIG. 3, to urge the actuator 52 upwardly through the cover 45. And, as will be apparent, a downward pressure on the actuator 52 will cause the link 56 to swing in a counter clockwise direction as viewed in FIG. 3 to depress the plunger 67 on switch 43 opening and closing said switch to control the actuation of the motor 39. As shown in FIG. 3, upward movement of the actuator 52 in the cover is limited by a radially projecting lip 70 formed on the

lower end of said actuator and engageable with the lower face of said cover.

As shown, an annular shield 74 is mounted on the frame web 22 between its offset 30 and outer margin 32 for rotation with said web. Said shield is formed from a lower leg 76 fixedly mounted on the upper face of the web and integrally connected to an upwardly projecting wall 78 interposed between the motor 39 and the inner edge of the pad portion 35. As shown, the wall 78 projects upwardly within the vertical extent of the cover 45 and is provided with an annular series of louvered openings 80 adjacent its upper edge. Thus, the wall 78 prevents any objects from entering the space between the pad and cover, but its openings 80 permit the entry of air into said space to prevent the motor 39 from becoming overheated, the louvered shape of said openings pulling air into said space during rotation of the frame and pad assembly.

In operation, the actuator 52 is depressed to swing the link 56 about the axis of pin 58 and close the switch 43 for energizing the motor 39. The motor rotatably drives the hub 20, and thus the web 22 and pad 34 about the axis of the post 12. During such rotation, the pad portions 35 and 36 provide annular horizontally and vertically oriented buffing surfaces, respectively, which are disposed in positions of easy access to the user to thus permit the entire surface of a shoe to be buffed. Objects will be prevented from entering the space between the cover 45 and pad 34 by the shield 74, and during rotation of said pad, the shield openings 80 will pull air into said space to prevent the motor from overheating. The unit may be turned off by merely depressing the actuator a second time.

We claim:

1. A shoe buffer, comprising a floor-engageable base supporting a post projecting upwardly therefrom, a mounting plate supported on said post at the upper end thereof, a motor mounted on said mounting plate, an annular frame rotatably supported on said post between said base and mounting plate and operatively connected to said motor for rotation about said post, an annular pad mounted on said frame for rotation therewith.

2. The invention as set forth in claim 1 in which said frame comprises an annular web fixedly connected to a hub rotatably mounted on said post.

3. The invention as set forth in claim 1 in which said frame projects generally horizontally outwardly from said post with its outer margin being curved upwardly, and said pad extends over the bottom face of said frame and its upwardly curved outer margin.

4. The invention as set forth in claim 1 in which said frame projects generally horizontally outwardly from said post and is provided with an upturned outer margin and an annular vertical offset intermediate said post and outer margin, and said pad comprises a horizontal lower portion extending outwardly from said offset interconnected by a vertically extending intermediate portion disposed against said outer margin of the frame to a horizontal upper portion projecting inwardly from said outer margin.

5. The invention as set forth in claim 1 with the addition that a cover is mounted on said mounting plate and extends over said motor and frame.

6. A shoe buffer, comprising a floor-engageable base supporting a post projecting upwardly therefrom, a mounting plate supported on said post at the upper end thereof, a motor mounted on said mounting plate, an

annular frame rotatably supported on said post between said base and mounting plate and operatively connected to said motor for rotation about said post, an annular pad extending around said frame, a cover mounted on said mounting plate and extending over said motor and frame, said cover having a downwardly projecting flange at its periphery terminating adjacent the upper portion of said pad, and an annular apertured shield projecting upwardly from said frame radially outwardly of said motor.

7. The invention as set forth in claim 6 in which the upper end of said shield is disposed within the vertical extent of said flange and said shield is provided with a set of circumferentially extending openings adjacent its upper end.

8. The invention as set forth in claim 7 in which said openings are louvered.

9. A shoe buffer, comprising a floor-engageable base supporting a post projecting upwardly therefrom, a mounting plate supported on said post at the upper end thereof, a motor mounted on said mounting plate, a hub rotatably supported on said post and having an outwardly projecting leg, means drivingly interconnecting said motor and leg for rotating said hub about said post, an annular outwardly projecting web fixedly connected to said leg for rotation with said hub, and an annular pad mounted on said web for rotation therewith.

10. A shoe buffer, comprising a floor-engageable base supporting a post projecting upwardly therefrom, a mounting plate supported on said post at the upper end thereof, a motor mounted on said mounting plate, an annular frame rotatably supported on said post between said base and mounting plate and operatively connected to said motor for rotation about said post, an annular pad extending around said frame, an annular cover mounted on said mounting plate and spaced upwardly therefrom to extend over said motor, frame, and pad, an actuator slidably mounted in said cover, a link swingably mounted on said mounting plate, and a switch for said motor mounted on said mounting plate, said link being disposed in bearing engagement with said actuator and switch whereby movement of said actuator will open and close said switch for controlling the operation of said motor.

11. The invention as set forth in claim 10 in which said switch is provided with a downwardly biased plunger bearing against said link to cause said link to urge said actuator upwardly through said cover.

12. The invention as set forth in claim 11 with the addition that said actuator is provided with an outwardly projecting lip engageable with said cover for limiting the upward movement of said actuator.

References Cited

UNITED STATES PATENTS

432,008	7/1890	Badger	15-34
759,015	5/1904	Rolph	15-36
928,341	7/1909	Stratton	15-34
977,432	12/1910	Burney	15-36
1,528,012	3/1925	Dodge	15-34
3,155,995	11/1964	Herrmann	15-36

FOREIGN PATENTS

59,362 2/1912 Switzerland.

WALTER A. SCHEEL, Primary Examiner.

LEON G. MACHLIN, Assistant Examiner.