



US010775032B2

(12) **United States Patent**
McIntyre et al.

(10) **Patent No.:** **US 10,775,032 B2**

(45) **Date of Patent:** **Sep. 15, 2020**

(54) **AREA LIGHT**

(71) Applicant: **Milwaukee Electric Tool Corporation**,
Brookfield, WI (US)

(72) Inventors: **Ross McIntyre**, Wauwatosa, WI (US);
Kyle Harvey, Wauwatosa, WI (US)

(73) Assignee: **Milwaukee Electric Tool Corporation**,
Brookfield, WI (US)

(*) Notice: Subject to any disclaimer, the term of this
patent is extended or adjusted under 35
U.S.C. 154(b) by 96 days.

(21) Appl. No.: **15/200,037**

(22) Filed: **Jul. 1, 2016**

(65) **Prior Publication Data**

US 2017/0003009 A1 Jan. 5, 2017

Related U.S. Application Data

(60) Provisional application No. 62/299,757, filed on Feb.
25, 2016, provisional application No. 62/187,539,
filed on Jul. 1, 2015.

(51) **Int. Cl.**

F21L 4/02 (2006.01)
F21S 9/02 (2006.01)
F21V 5/04 (2006.01)
F21L 14/02 (2006.01)
F21V 21/40 (2006.01)

(Continued)

(52) **U.S. Cl.**

CPC **F21V 23/003** (2013.01); **F21S 9/02**
(2013.01); **F21V 5/04** (2013.01); **F21V 21/406**
(2013.01); **H05B 45/00** (2020.01); **H05B**
47/10 (2020.01); **F21L 4/02** (2013.01); **F21L**
14/02 (2013.01); **F21V 23/04** (2013.01); **F21V**
29/74 (2015.01);

(Continued)

(58) **Field of Classification Search**

None

See application file for complete search history.

(56) **References Cited**

U.S. PATENT DOCUMENTS

3,331,958 A 7/1967 Adler
3,755,668 A * 8/1973 Moreschini F21L 14/02
362/282

(Continued)

FOREIGN PATENT DOCUMENTS

EP 0193756 9/1986
EP 1205428 5/2002

(Continued)

OTHER PUBLICATIONS

International Search Report and Written Opinion for Application
No. PCT/US2017/018412 dated May 23, 2017 (13 pages).

(Continued)

Primary Examiner — Britt D Hanley

(74) *Attorney, Agent, or Firm* — Michael Best &
Friedrich LLP

(57) **ABSTRACT**

An area light includes a housing defining a central axis and including a first portion and a second portion, the second portion arranged to emit light. A lens is coupled to the housing, and a light assembly is disposed within the second portion. The light assembly includes a plurality of LEDs arranged to emit light through the lens and in a direction that extends 360 degrees around the central axis. A battery is selectively coupled to the housing and is arranged to provide power to the LEDs to allow for the emission of light at a level of at least 5700 lumens for at least two hours.

20 Claims, 8 Drawing Sheets

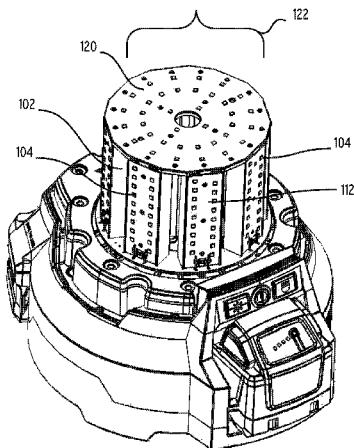

(51)	Int. Cl.								
	<i>F21V 23/00</i>	(2015.01)		7,503,530	B1	3/2009	Brown		
	<i>F21V 23/04</i>	(2006.01)		7,566,151	B2	7/2009	Whelan et al.		
	<i>F21V 29/74</i>	(2015.01)		7,618,154	B2	11/2009	Rosiello		
	<i>H05B 33/08</i>	(2006.01)		7,638,970	B1	12/2009	Gebhard et al.		
	<i>H05B 37/02</i>	(2006.01)		D612,965	S	3/2010	Extrand		
	<i>F21W 131/10</i>	(2006.01)		7,670,034	B2	3/2010	Zhang et al.		
	<i>F21Y 115/10</i>	(2016.01)		D621,536	S	8/2010	Lee		
	<i>H05B 45/00</i>	(2020.01)		D622,430	S	8/2010	Chilton		
	<i>H05B 47/10</i>	(2020.01)		7,798,684	B2	9/2010	Boissevain		
(52)	U.S. Cl.			7,828,465	B2	11/2010	Roberge et al.		
	CPC .. <i>F21W 2131/1005</i>	(2013.01); <i>F21Y 2115/10</i>		7,857,486	B2	12/2010	Long et al.		
		(2016.08)		7,914,178	B2	3/2011	Xiang et al.		
				7,914,182	B2	3/2011	Mrakovich et al.		
				7,972,036	B1	7/2011	Schach et al.		
				D643,138	S	8/2011	Kawase et al.		
				7,988,335	B2	8/2011	Liu et al.		
				7,990,062	B2	8/2011	Liu		
				7,997,753	B2	8/2011	Walesa et al.		
(56)	References Cited			8,007,128	B2	8/2011	Wu et al.		
	U.S. PATENT DOCUMENTS			8,007,145	B2	8/2011	Leen		
				8,029,169	B2	10/2011	Liu		
				8,047,481	B2	11/2011	Shen		
				8,087,797	B2	1/2012	Pelletier et al.		
				8,142,045	B2	3/2012	Peak		
				8,167,466	B2	5/2012	Liu		
				D661,417	S	6/2012	Kung		
				8,201,979	B2	6/2012	Deighton et al.		
				D665,521	S	8/2012	Werner et al.		
				8,235,552	B1	8/2012	Tsuge		
				8,262,248	B2	9/2012	Wessel		
				8,294,340	B2	10/2012	Yu et al.		
				8,322,892	B2	12/2012	Scordino et al.		
				8,328,398	B2	12/2012	Van Deursen		
				8,330,337	B2	12/2012	Yu et al.		
				8,360,607	B2	1/2013	Bretschneider et al.		
				8,366,290	B2	2/2013	Maglica		
				8,403,522	B2	3/2013	Chang		
				8,425,091	B2	4/2013	Chen		
				8,439,531	B2	5/2013	Trott et al.		
				8,465,178	B2	6/2013	Wilcox et al.		
				8,485,691	B2	7/2013	Hamel et al.		
				D687,591	S	8/2013	Chilton et al.		
				8,547,022	B2	10/2013	Summerford et al.		
				D694,445	S	11/2013	Shiu		
				D695,434	S	12/2013	Shen		
				8,599,097	B2	12/2013	Intravatora		
				D698,471	S	1/2014	Poon		
				D699,874	S	2/2014	Chilton et al.		
				8,651,438	B2	2/2014	Deighton et al.		
				8,659,433	B2	2/2014	Petrou		
				8,692,444	B2	4/2014	Patel et al.		
				8,696,177	B1	4/2014	Frost		
				D705,467	S	5/2014	Aglassinger		
				D706,968	S	6/2014	McDonough et al.		
				D708,376	S	7/2014	Crowe et al.		
				8,801,226	B2	8/2014	Moore		
				8,851,699	B2	10/2014	McMillan		
				8,858,016	B2	10/2014	Strelchuk		
				8,858,026	B2	10/2014	Lee et al.		
				8,939,602	B2	1/2015	Wessel		
				8,979,331	B2	3/2015	Lee et al.		
				D726,354	S	4/2015	Davies		
				D728,402	S	5/2015	Case		
				9,068,736	B2	6/2015	Lee et al.		
				9,182,088	B2	11/2015	Workman et al.		
				D747,263	S	1/2016	Lafferty		
				9,713,216	B2	7/2017	Urry et al.		
				9,851,088	B2 *	12/2017	Harvey F21V 29/83		
				D809,687	S *	2/2018	Krantz D26/40		
				D822,246	S	7/2018	Hou		
				D828,939	S	9/2018	Bo		
				2002/0136005	A1	9/2002	Lee		
				2002/0167814	A1	11/2002	Ching		
				2002/0191396	A1 *	12/2002	Reiff F21L 4/04		
									362/184
				2003/0090904	A1	5/2003	Ching		
				2003/0137847	A1	7/2003	Cooper		
				2003/0174503	A1	9/2003	Yueh		
				2005/0265035	A1	12/2005	Brass et al.		
				4,032,771	A	6/1977	Ilzig		
				4,228,489	A	10/1980	Martin		
				4,268,894	A	5/1981	Bartunek et al.		
				4,324,477	A	4/1982	Miyazaki		
				5,203,621	A	4/1993	Weinmeister et al.		
				5,207,747	A	5/1993	Gordin et al.		
				5,351,172	A	9/1994	Attree et al.		
				5,400,234	A	3/1995	Yu		
				5,428,520	A	6/1995	Skief		
				5,630,660	A	5/1997	Chen		
				5,860,729	A *	1/1999	Bamber F21L 4/02		
									362/184
				5,934,628	A	8/1999	Bosnakovic		
				5,964,524	A	10/1999	Qian		
				6,045,240	A	4/2000	Hochstein		
				D428,176	S	7/2000	Bamber et al.		
				6,092,911	A	7/2000	Baker, III et al.		
				6,099,142	A	8/2000	Liu		
				6,149,283	A	11/2000	Conway et al.		
				6,183,114	B1	2/2001	Cook et al.		
				6,213,626	B1	4/2001	Qian		
				6,255,786	B1	7/2001	Yen		
				6,265,969	B1	7/2001	Shih		
				D452,022	S	12/2001	Osiecki et al.		
				6,367,949	B1	4/2002	Pederson		
				6,379,023	B1	4/2002	Passno		
				6,461,017	B2	10/2002	Selkee		
				6,474,844	B1	11/2002	Ching		
				6,554,459	B2	4/2003	Yu et al.		
				6,637,904	B2	10/2003	Hernandez		
				6,824,297	B1	11/2004	Lee		
				6,854,862	B1	2/2005	Hoof		
				6,857,756	B2	2/2005	Reiff et al.		
				6,873,249	B2	3/2005	Chu		
				6,877,881	B2	4/2005	Tsao		
				6,899,441	B2	5/2005	Chen		
				D506,847	S	6/2005	Hussaini et al.		
				6,902,294	B2	6/2005	Wright		
				6,926,428	B1	8/2005	Lee		
				7,001,044	B2	2/2006	Leen		
				7,001,047	B2	2/2006	Holder et al.		
				7,011,280	B2	3/2006	Murray et al.		
				7,063,444	B2	6/2006	Lee et al.		
				7,073,926	B1	7/2006	Kremers et al.		
				D532,536	S	11/2006	Krieger et al.		
				7,152,997	B1	12/2006	Kovacik et al.		
				7,153,004	B2	12/2006	Galli		
				7,194,358	B2	3/2007	Callaghan et al.		
				7,195,377	B2	3/2007	Tsai		
				7,224,271	B2	5/2007	Wang		
				D553,281	S	10/2007	Rugendyke et al.		
				D553,771	S	10/2007	Watson et al.		
				7,278,761	B2	10/2007	Kuan		
				7,350,940	B2	4/2008	Haugaard et al.		
				7,364,320	B2	4/2008	Van Deursen et al.		
				7,367,695	B2	5/2008	Shiau		
				7,470,036	B2	12/2008	Deighton et al.		
				7,484,858	B2	2/2009	Deighton et al.		

(56)

References Cited

U.S. PATENT DOCUMENTS

2006/0007682 A1 1/2006 Reiff, Jr. et al.
 2006/0067077 A1 3/2006 Kumthampinij et al.
 2006/0146550 A1 7/2006 Simpson et al.
 2006/0203478 A1 9/2006 Waters
 2006/0279948 A1 12/2006 Tsai
 2006/0285323 A1 12/2006 Fowler
 2007/0211470 A1 9/2007 Huang
 2007/0297167 A1 12/2007 Greenhoe
 2008/0112170 A1 5/2008 Trott et al.
 2008/0158887 A1 7/2008 Zhu et al.
 2008/0165537 A1 7/2008 Shiau
 2008/0198588 A1 8/2008 O'Hern
 2008/0253125 A1 10/2008 Kang et al.
 2008/0302933 A1 12/2008 Cardellini
 2009/0080205 A1 3/2009 Chang et al.
 2009/0134191 A1 5/2009 Phillips
 2009/0135594 A1 5/2009 Yu et al.
 2009/0303717 A1 12/2009 Long et al.
 2010/0027260 A1 2/2010 Liu
 2010/0027269 A1 2/2010 Lo et al.
 2010/0072897 A1 3/2010 Zheng
 2010/0080005 A1 4/2010 Gattari
 2010/0091495 A1 4/2010 Patrick
 2010/0142213 A1 6/2010 Bigge et al.
 2010/0315824 A1 12/2010 Chen
 2010/0328951 A1 12/2010 Boissevain
 2011/0031887 A1 2/2011 Stoll et al.
 2011/0038144 A1 2/2011 Chang
 2011/0050070 A1 3/2011 Pickard
 2011/0058367 A1 3/2011 Shiau et al.
 2011/0075404 A1 3/2011 Allen et al.
 2011/0089838 A1 4/2011 Pickard et al.
 2011/0121727 A1 5/2011 Sharrah et al.
 2011/0156584 A1 6/2011 Kim
 2011/0228524 A1 9/2011 Greer
 2011/0286216 A1 11/2011 Araman
 2011/0317420 A1 12/2011 Jeon et al.
 2012/0026729 A1 2/2012 Sanchez et al.
 2012/0033400 A1 2/2012 Remus et al.
 2012/0033429 A1 2/2012 Van De Ven
 2012/0044707 A1 2/2012 Breidenassel
 2012/0048511 A1 3/2012 Moshtagh
 2012/0049717 A1 3/2012 Lu
 2012/0057351 A1 3/2012 Wilcox et al.
 2012/0087118 A1 4/2012 Bailey et al.
 2012/0087125 A1 4/2012 Liu
 2012/0098437 A1 4/2012 Smed
 2012/0120674 A1 5/2012 Jonker
 2012/0140455 A1 6/2012 Chang
 2012/0155104 A1 6/2012 Jonker

2012/0212963 A1 8/2012 Jigamian
 2012/0234519 A1 9/2012 Lee
 2012/0236551 A1 9/2012 Sharrah et al.
 2012/0247735 A1 10/2012 Ito et al.
 2012/0262917 A1 10/2012 Courcelle
 2012/0300487 A1 11/2012 Jonker
 2013/0032323 A1 2/2013 Hsu
 2013/0058078 A1 3/2013 Meng
 2013/0077296 A1 3/2013 Goeckel et al.
 2013/0128565 A1 5/2013 Cugini et al.
 2013/0176713 A1 7/2013 Deighton et al.
 2013/0187785 A1 7/2013 McIntosh et al.
 2013/0258645 A1* 10/2013 Weber F2IL 4/08
 362/183
 2013/0265780 A1 10/2013 Choski et al.
 2013/0322073 A1 12/2013 Hamm et al.
 2014/0140050 A1* 5/2014 Wong F2IL 4/02
 362/184
 2014/0192543 A1 7/2014 Deighton et al.
 2014/0218936 A1 8/2014 Mahling et al.
 2014/0268775 A1 9/2014 Kennemer et al.
 2014/0301066 A1 10/2014 Inskeep
 2014/0307443 A1 10/2014 Clifford et al.
 2014/0376216 A1 12/2014 McLoughlin et al.
 2015/0023771 A1 1/2015 Carr et al.
 2015/0233569 A1 8/2015 Xue et al.
 2015/0233571 A1 8/2015 Inan et al.
 2015/0267902 A1* 9/2015 Zhang F2IL 4/04
 362/188
 2016/0348879 A1 12/2016 Young et al.
 2016/0360585 A1 12/2016 Urry et al.
 2017/0280528 A1 9/2017 Urry et al.

FOREIGN PATENT DOCUMENTS

EP 2436641 4/2012
 GB 2424694 10/2006
 KR 20100089371 A 8/2010
 KR 20100116933 11/2010
 WO 2002044503 6/2002
 WO WO-2011073828 A1 6/2011
 WO WO-2011112005 A2 9/2011
 WO 2014083117 6/2014
 WO 2014207595 12/2014

OTHER PUBLICATIONS

European Patent Office Partial Supplementary Search Report for Application No. 17757035.5 dated Sep. 19, 2019 (14 pages).
 European Patent Office Extended Search Report for Application No. 17757035.5 dated Jan. 3, 2020 (11 pages).

* cited by examiner

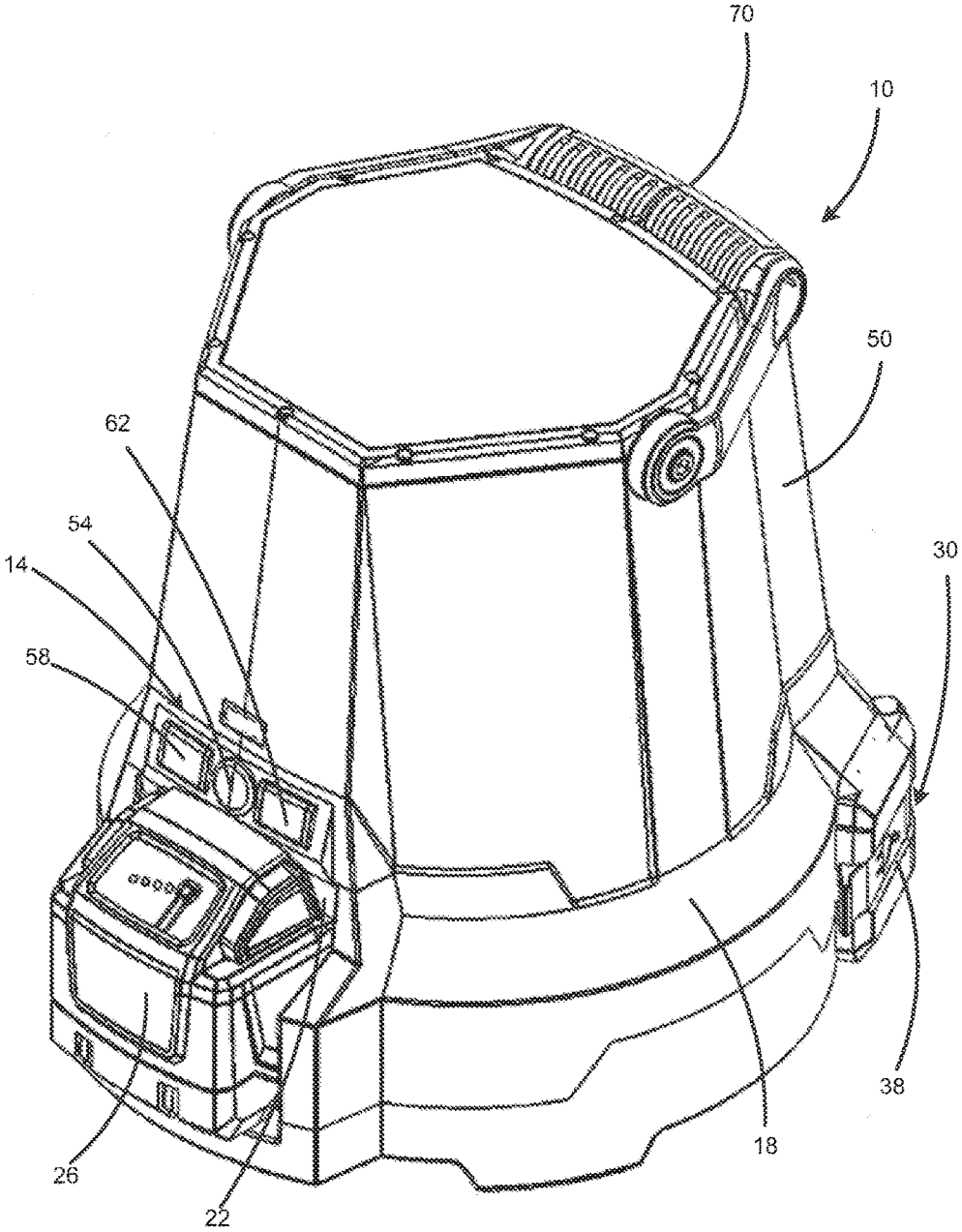

FIG. 1

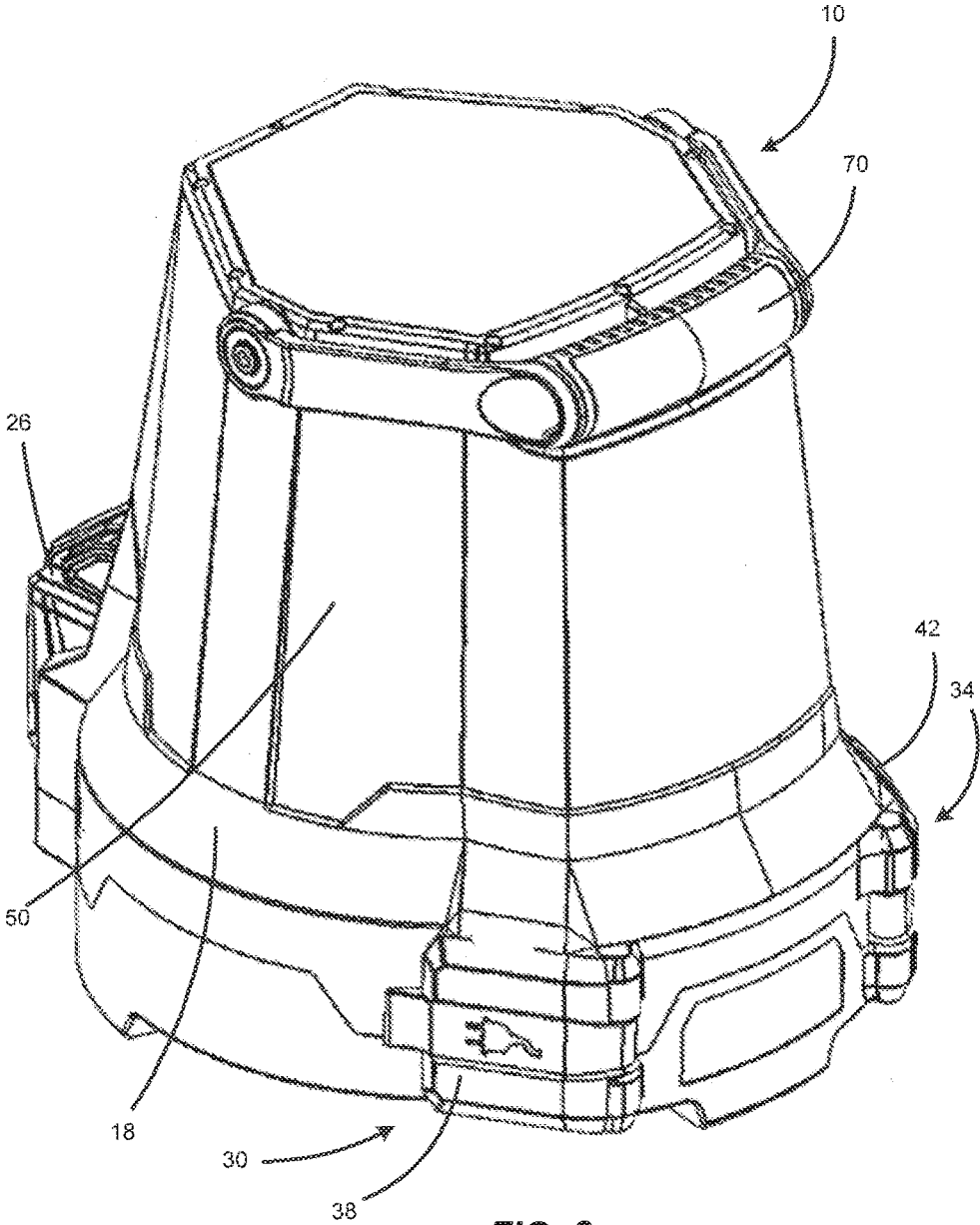

FIG. 2

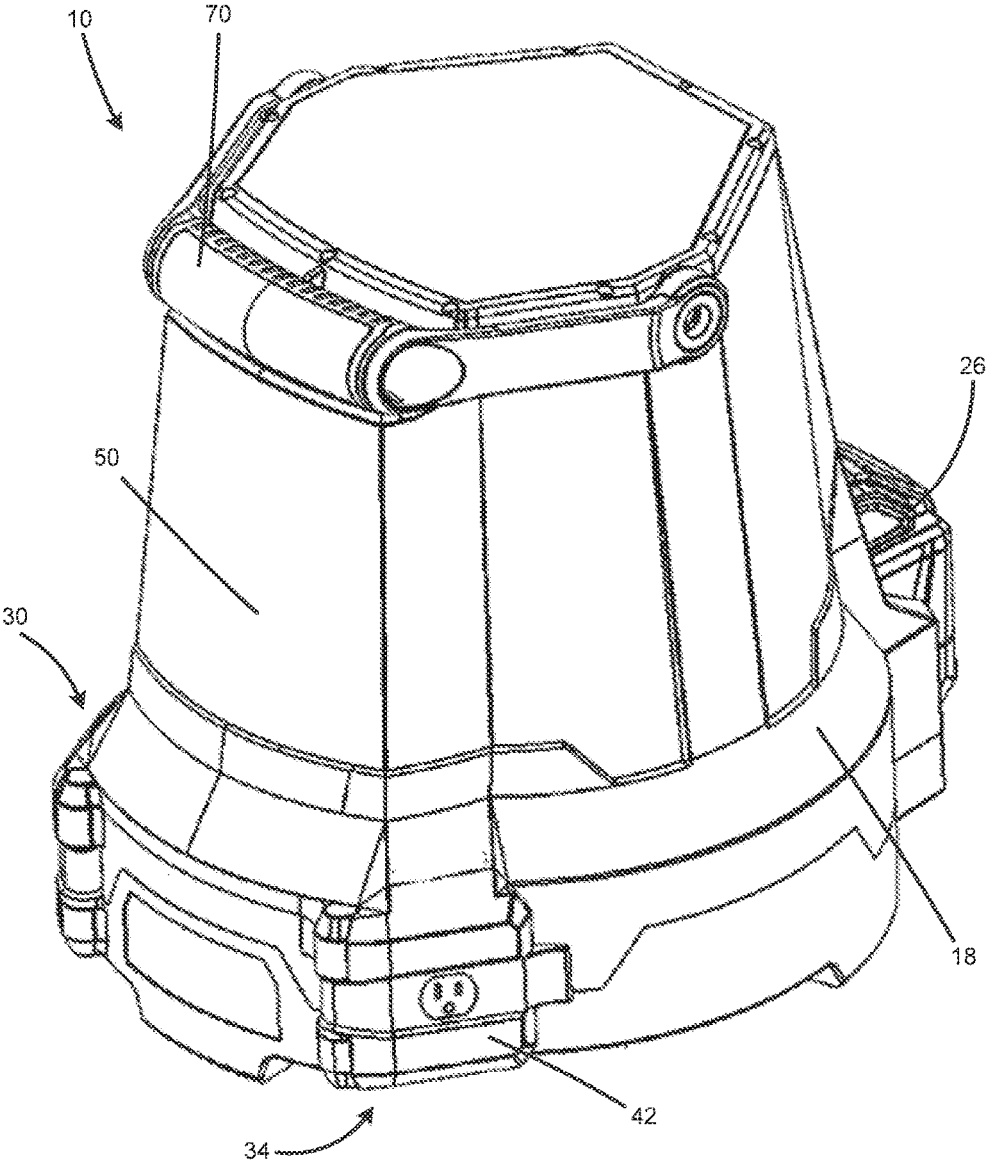

FIG. 3

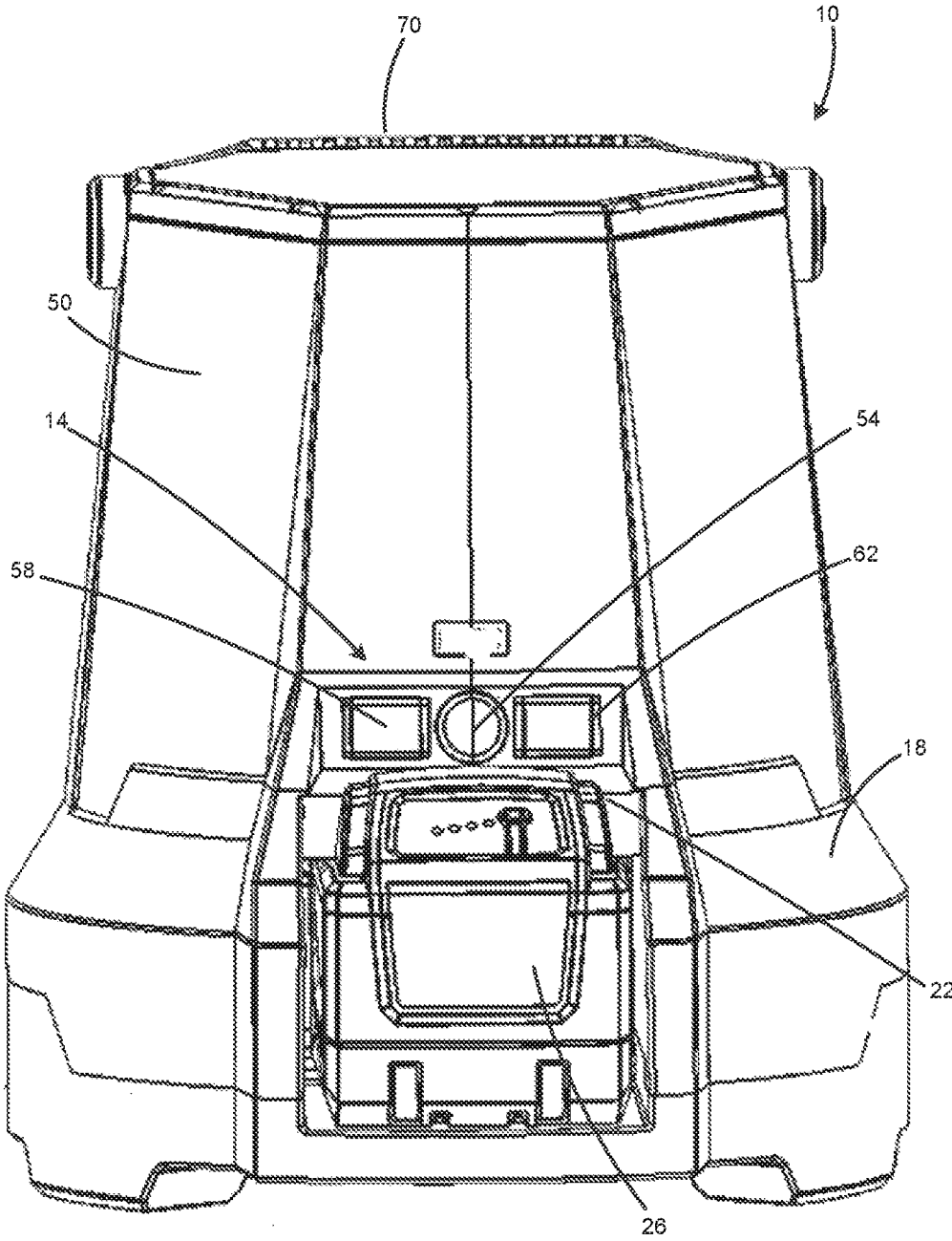

FIG. 4

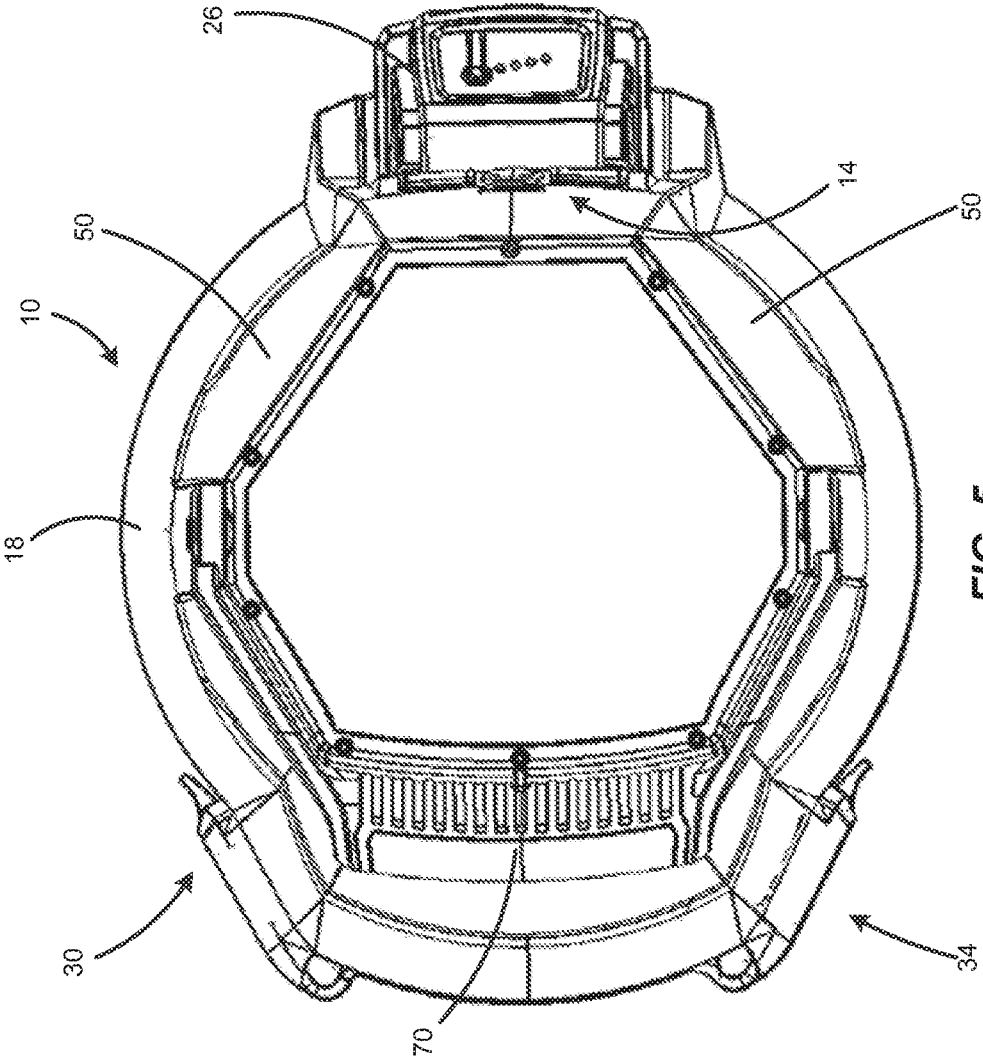

FIG. 5

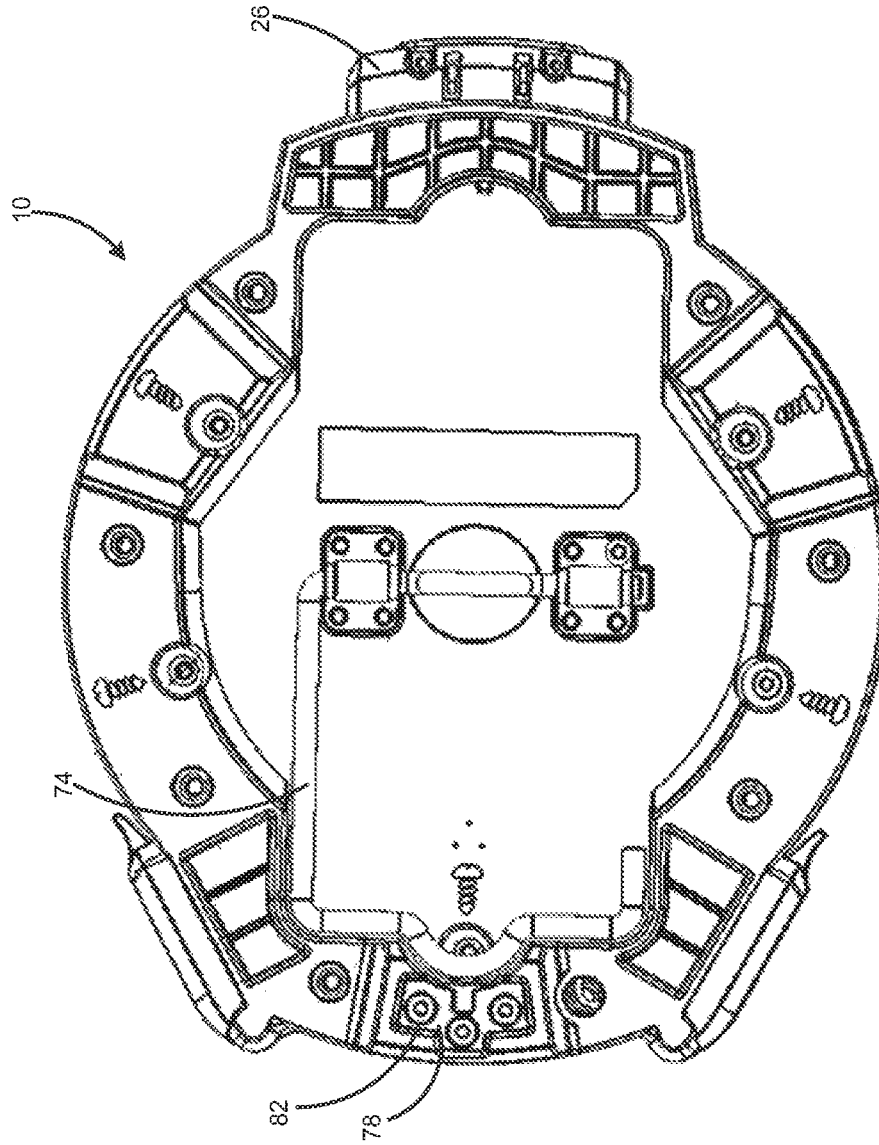

FIG. 6

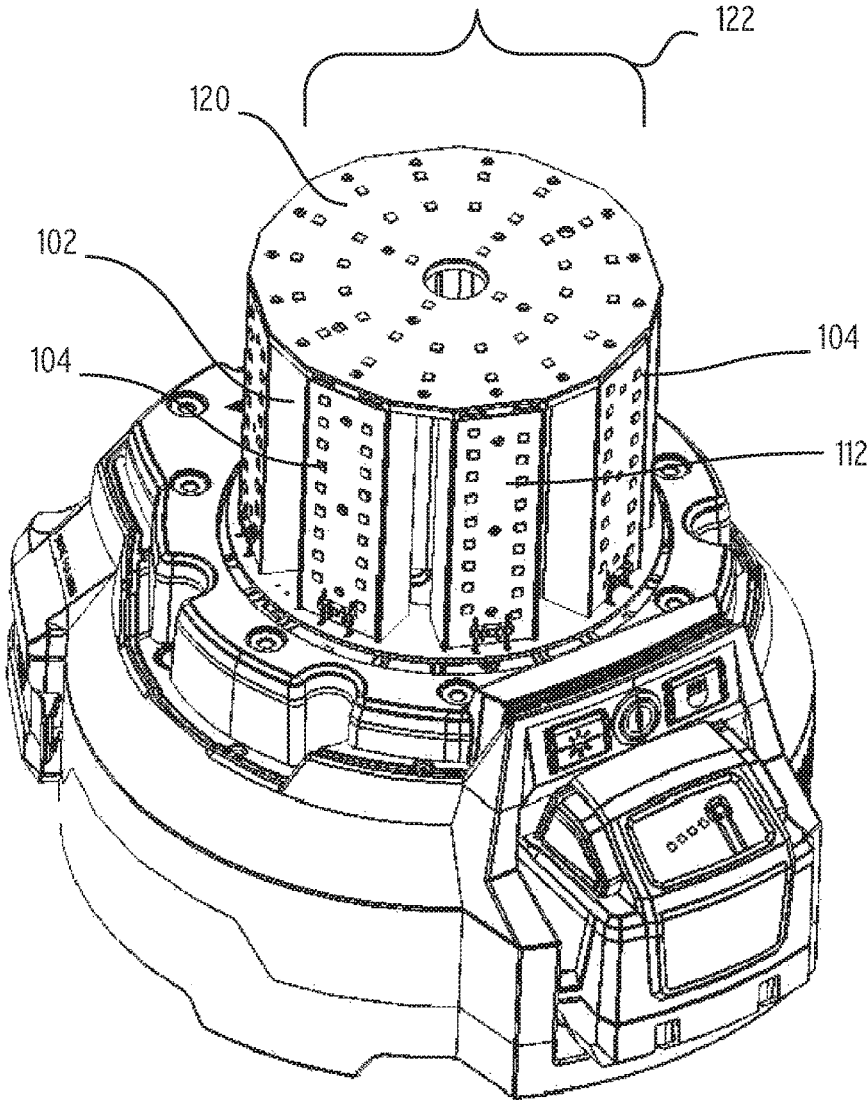

FIG. 7

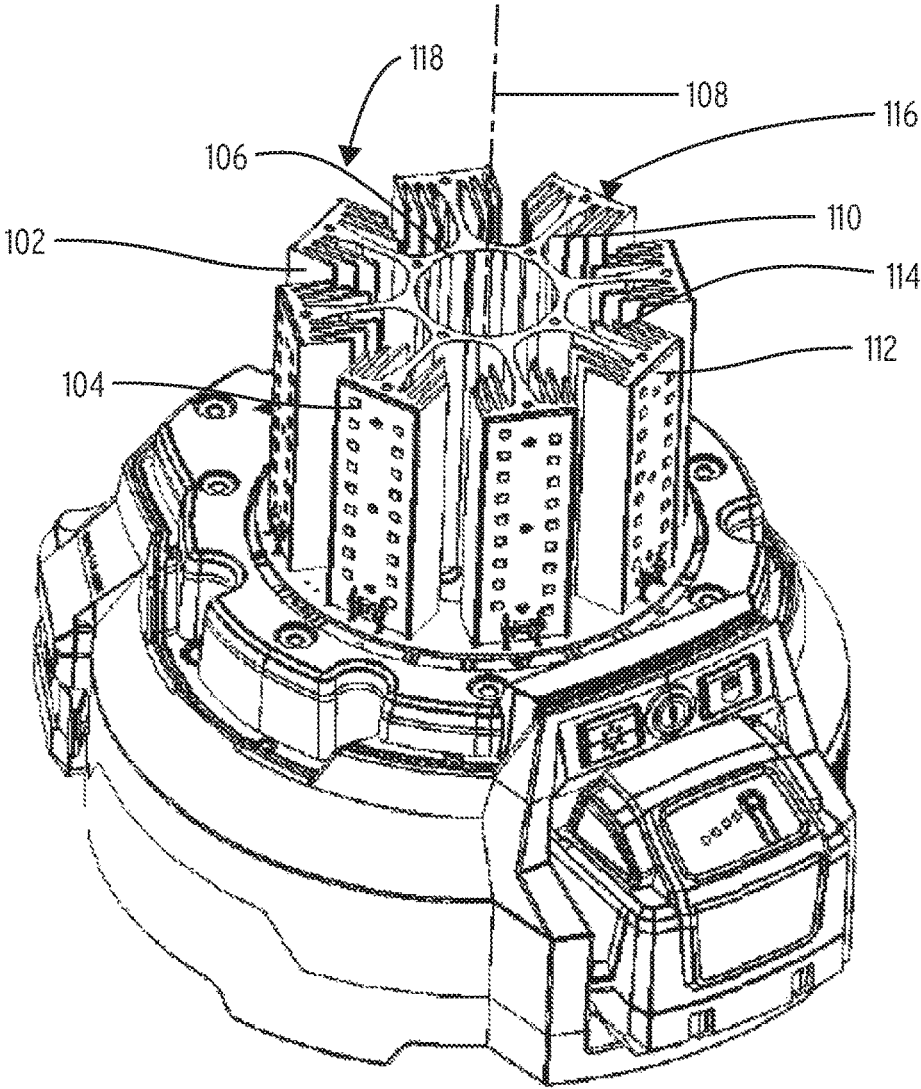

FIG. 8

1

AREA LIGHT

RELATED APPLICATION DATA

The present application claims priority to U.S. Provisional Application No. 62/299,757 filed Feb. 25, 2016 and U.S. Provisional Application No. 62/187,539 filed Jul. 1, 2015.

BACKGROUND

The present invention relates lighting devices, and more particularly to portable workspace lighting devices.

SUMMARY

The present invention provides, in one aspect, an area light including a power inlet connectable to a power source, a housing supporting a light assembly, and a user interface including control members configured to operate the light assembly between multiple modes of operation.

In accordance with some constructions, the power source is a battery, the light assembly is an array of LEDs, and the user interface includes a first control member for turning the light assembly on and off and a second control member for operating the light between two or more intensity levels.

In accordance with some constructions, the battery is a 5 amp/hour battery and is capable of providing power to the array of LEDs to produce between 5700 lumens and 7700 lumens for 1 to 3 hours. More specifically, the battery is configured to provide power to the array of LEDs to produce 6700 lumens for about 2 hours.

In accordance with some constructions, the light assembly is an array of 80 to 280 LEDs. More specifically, the light assembly is an array of 180 LEDs. This array of LEDs may be configured to emit light at approximately 3700-4300 Kelvin with a color rendering index (CRI) between about 50 and 100. More specifically, the light that is emitted by the LEDs is about 4000 Kelvin with a CRI of about 70.

In accordance with some constructions, the housing includes a lens surrounding the light assembly. The lens is configured to withstand a two meter drop test. The lens may be removably coupled to the housing. When the lens is coupled to the housing and surrounds the light assembly, approximately 3500-5500 lumens passes through the lens. More specifically, approximately 4500 lumens will pass through the lens.

In one construction, an area light includes a housing defining a central axis and including a first portion and a second portion, the second portion arranged to emit light. A lens is coupled to the housing, and a light assembly is disposed within the second portion. The light assembly includes a plurality of LEDs arranged to emit light through the lens and in a direction that extends 360 degrees around the central axis. A battery is selectively coupled to the housing and is arranged to provide power to the LEDs to allow for the emission of light at a level of at least 5700 lumens for at least two hours.

In another construction, an area light includes a housing defining a central axis and including a first portion and a second portion, a lens coupled to the housing and disposed substantially within the second portion, and a light assembly arranged to emit light from each of a plurality of sectors arranged around the central axis, the plurality of sectors cooperating to completely surround the central axis. A plurality of LEDs is arranged in each of the plurality of sectors, and a control unit is operable to control the distribution of electrical power to the plurality of LEDs, and to

2

selectively direct power to all of the plurality of sectors or to a subset of the plurality of sectors.

In yet another construction, an area light includes a housing defining a central axis and a light assembly defining a plurality of sectors that extend 360 degrees around the central axis, each of the plurality of sectors including a plurality of LEDs arranged to emit light in a direction substantially normal to the central axis. A planar sector is arranged normal to the central axis and includes a plurality of top LEDs arranged to emit light in a direction substantially parallel to the central axis. A lens is coupled to the housing and covers the light assembly and the planar sector, a port is formed as part of the housing and sized to selectively receive a battery, and a power inlet is arranged to selectively receive electrical power from an AC source of power. A control unit is operable to control the distribution of electrical power from one of the port and the power inlet to the plurality of LEDs, and is operable to selectively direct power to all of the plurality of sectors or to a subset of the plurality of sectors.

Other features and aspects of the invention will become apparent by consideration of the following detailed description and accompanying drawings.

BRIEF DESCRIPTION OF THE DRAWINGS

FIG. 1 is a front perspective view of an area light.

FIG. 2 is a first side, rear perspective view of the area light.

FIG. 3 is a second side, rear perspective view of the area light.

FIG. 4 is a front view of the area light.

FIG. 5 is a top view of the area light.

FIG. 6 is a bottom view of the area light.

FIG. 7 is a perspective view of the area light of FIG. 1 with the lens removed.

FIG. 8 is a perspective view of the area light of FIG. 7 with a portion of the light assembly and the lens removed.

Before any embodiments of the invention are explained in detail, it is to be understood that the invention is not limited in its application to the details of construction and the arrangement of components set forth in the following description or illustrated in the following drawings. The invention is capable of other embodiments and of being practiced or of being carried out in various ways. Also, it is to be understood that the phraseology and terminology used herein is for the purpose of description and should not be regarded as limiting.

DETAILED DESCRIPTION

FIGS. 1-6 illustrate an area light 10 configured to provide illumination to a workspace. The area light 10 may be held by a user or hung on a support member using features discussed in greater detail below. In addition, the area light 10 may be controlled via a user interface 14 to operate in a plurality of lighting modes.

With reference to FIG. 1-3, the area light 10 includes a housing 18 with a port 22 configured to detachably support a battery 26 at one end. The housing 18 also includes a power inlet 30 (e.g., AC power inlet, etc.) and a power outlet 34 (e.g., standard three pin adapter, any standard outlet used in countries around the world, etc.) spaced from the port 22 and configured to, among other things, allow for multiple lights 10 to be connected to the same power source via connections with other lights 10. Put simply, multiple lights 10 may be 'daisy-chained' together. In the illustrated con-

struction, the power inlet **30** and the power outlet **34** are selectively covered by pivoting doors **38**, **42** such that the inlet **30** and the outlet **34** may be covered and protected when they are not in use.

The battery **26** and/or an external power source are configured to supply power to a light assembly **46** via the port **22** and the power inlet **30**, respectively. In preferred constructions, the battery **26** is a power tool battery pack that can be inserted into the port **22** and removed from the port **22** without any disassembly of the light **10**. In one construction, the light assembly **46** includes an array of LEDs. For example, the light assembly **46** may be an array of about 80-280 LEDs. More specifically, the light assembly **46** may be an array of 180 LEDs. In a specific example, the array of LEDs is configured to generate approximately 5700-7700 lumens for about two hours when powered by a 5 amp/hour battery. Further, the light that is emitted by the LEDs is approximately 3700-4300 Kelvin with a color rendering index (CRI) between about 50 and 100. More specifically, the light that is emitted is about 4000 Kelvin with a CRI of about 70.

With reference to FIGS. 1-4, the housing **18** is also configured to support a lens **50** that surrounds the light assembly **46**. In some constructions, the lens **50** may be detachably coupled to the housing **18**. For example, the lens **50** may be coupled to the housing **18** using a set of fasteners, a ball detent, an interference fit, or other suitable mechanisms.

In some constructions, the lens **50** is be configured to withstand a two meter drop test without any adverse functional effects. This may be accomplished by having a certain lens thickness or by constructing the lens **50** from various materials. In addition, the lens **50** is also configured to have specific light transmission properties—that is, the lens **50** may be configured to transmit a certain percentage, color, or other light characteristic from the light assembly **46** to the surrounding workspace. In a specific example, the lens **50** is configured to transmit approximately 3500-5500 lumens from the light assembly to the work space. More specifically, the lens **50** is configured to transmit 4500 lumens from the light assembly **46** to the work space. The lens also shifts the color temperature of the light by about 200 Kelvin such that the light exiting the lens has a color temperature between about 3500 Kelvin and 4100 Kelvin.

With reference to FIGS. 1 and 4, the area light **10** includes the user interface **14** disposed on the housing **18**. In the illustrated construction, the user interface **14** includes a first control member **54**, a second control member **58**, and a third control member **62**. The first control member **54** may be a button, switch, or any suitable control mechanism that is configured to toggle the light assembly **46** between an energized state (i.e., on) and a de-energized state (i.e., off). The second control member **58** may also be a button, switch or any suitable control mechanism that is configured to toggle sections of the light assembly **46** on and off. Accordingly, the light assembly **46** may be operated such that only portions of the light assembly **46** are energized. For example, one half (divided along any axis) of the light assembly **46** may be energized while the other half is de-energized, and vice versa. The third control member **62** also may be a button, switch or any suitable control mechanism that is configured to control the intensity of light emitted by the light assembly **46**. For example, the third control member **62** may operate the light between a high intensity, medium intensity, and low intensity. Other intermediate intensities may be included as well. In the specific example of the LED light assembly described above, the

light intensity control is accomplished using pulse width modulation, although other alternative methods known in the art may be used. While three separate control members are illustrated and described, other constructions may combine some of the functions described into fewer than three control members or may include additional control members that allow for different operating functions.

The area light **10** also includes an internal control unit **66**, such as a microcontroller or memory unit storing information and executable functions. The internal control unit **66** is configured to store the state of the light as set by the second and third control members **58**, **62** when the light assembly **46** is powered on and off by the first control member **54**. This results in a light **10** that may be turned on and off while maintaining the most recent state of the light (e.g., the section of the light turned on and the intensity level), thereby allowing the user to turn the light on with the last settings without having to adjust the light.

With reference to FIG. 5, the area light **10** includes a pivotable handle **70** having a portion configured to be grasped by a user. Alternatively, the handle **70** may also be configured to be hung on a support member within a workspace (e.g., a hook, a rod, etc.) to hang the light above the ground. The handle **70** is shown in a stowed position and is pivotable to a carrying position in which a user can carry the light **10** or hang the light **10** on a support member.

With reference to FIG. 6, the area light **10** includes a pivotable hook **74** and a reinforced support plate **78** within a slot **82**. The pivotable hook **74** defines an open end **76** such that the hook **74** may be pivoted relative to the light **10** in order to facilitate the hanging of the light **10** on a support member within the work space. The slot **82** is configured to receive a support member, such as a fastener head or hook, with the support member abutting the support plate **78**. In this manner, the light **10** may be hung within on the support member within the work space.

In operation, the handle **70**, the pivotable hook **74**, and the slot **82** allow a user to couple the area light **10** to a support member in the work space. Using the user interface **14**, the user may energize the light assembly **46** using the first control member **54** and adjust other light assembly characteristics using the second and third control members **58**, **62**. For example, the user may operate the light assembly at a desired intensity while also energizing only a portion of the light.

The light may also include a power control circuit that allows the light to select the power source from which, or to which power is delivered. For example, the power control circuit could be arranged to deliver power to the LEDs from the external power source when that power source is available and to automatically switch to or select the battery as the source when the external source is not available. In addition, the battery could be charged by the external power source while the external power source delivers power to the LEDs.

FIGS. 7 and 8 show the area light of FIGS. 1-6 with the lens **50** removed to better illustrate features of the light assembly **46**. With reference to FIG. 8, the light assembly **46** includes a heat sink **102** that supports a quantity of LEDs **104**. The heat sink **102** includes a central tube portion **106** that extends along a central axis **108** and eight arms **110** extending radially outward from the central tube **106**. Each of the arms **110** includes an outward facing surface **112** on which a number of LEDs **104** are attached. A number of fins **114** extend inward toward the central tube **106** from the outward facing surface **112** to enhance the cooling ability of the heat sink **102**. Each of the arms **110** (or groups of arms

5

110) defines a sector 116, with the sectors 116 extending 360 degrees around the central axis 108 or the central tube 106. The user interface 14, first control member 54, second control member 58, third control member 62, or control unit are operable to activate the LEDs 104 on a per sector basis. Thus, in use, a user could activate the LEDs 104 on a single sector 116 or multiple sectors 116 as may be desired. In one construction, two adjacent arms 110 define a sector 118 such that the user can activate the light to illuminate a 90 degree wedge, a 180 degree wedge, a 270 degree wedge, or the entire 360 degree area around the light 10. The control unit is capable of storing the on/off configuration of the various sectors 116, 118 when the light 10 is turned off to allow the same sector on/off configuration when the light 10 is reactivated.

As illustrated in FIG. 7, a plate 120 is positioned on top of the heat sink 102 and includes a number of LEDs 104 arranged to direct light in a direction parallel to the central axis 108. The plate 120 and LEDs 104 define a planar sector 122 that can be controlled as a separate sector 122 as discussed with regard to FIG. 8 or can be grouped with another sector 116, 118 of the light 10.

Although the invention has been described in detail with reference to certain preferred embodiments, variations and modifications exist within the scope and spirit of one or more independent aspects of the invention as described.

What is claimed is:

1. An area light comprising:
 - a housing defining a central axis and having a first end and a second end that is opposite the first end, the housing having a side including a battery port;
 - a lens coupled to the first end of the housing;
 - a light assembly disposed within the lens, the light assembly including a heat sink having a surface facing away from the first end of the housing and a plurality of arms extending radially outward from the central axis, the surface including one or more LEDs arranged to emit light through the lens and in a direction that extends 360 degrees around the central axis;
 - a battery selectively coupled to the battery port and arranged to provide power to the LEDs;
 - a pivotable hook coupled to the second end of the housing, the pivotable hook configured to pivot with respect to the second end of the housing, and
 - a user interface including
 - a first control member configured to turn the one or more LEDs on and off, and
 - a second control member configured to switch the one or more LEDs between a first intensity and a second intensity that is higher than the first intensity, wherein the light passing through the lens has a range of between 3500 and 5500 lumens.
2. The area light of claim 1, further comprising a slot on the second end of the housing and configured to receive a support member that is configured to support the light.
3. The area light of claim 2, further comprising a support plate arranged in the slot.
4. The area light of claim 1, wherein the one or more LEDs are selected to emit light with a color rendering index between 50 and 100.
5. The area light of claim 4, wherein the light passing through the lens has a temperature that is between 3500 and 4100 Kelvin.
6. The area light of claim 5, wherein the battery port is arranged between the light assembly and the second end of the housing.

6

7. The area light of claim 6, wherein the lens has a width that tapers as the lens extends away from the first end of the housing.

8. The area light of claim 7, wherein the lens is detachably coupled to the first end of the housing.

9. The area light of claim 8, further comprising a control unit operable to control the distribution of electrical power to the one or more LEDs.

10. The area light of claim 9, wherein the control unit is configured to store an intensity level of the one or more LEDs when the light assembly is powered on and off, such that the light assembly may be turned on and off while maintaining the most recent intensity level of the one or more LEDs.

11. An area light comprising:

- a housing defining a central axis and having a first end and a second end that is opposite the first end;
- a lens coupled to a first end of the housing and having a width, the width of the lens tapering as the lens extends away from the first end of the housing;
- a light assembly including a plurality of arms extending radially outward from the central axis, the light assembly including one or more LEDs arranged to emit light through the lens and in a direction that extends 360 degrees around the central axis;
- a control unit operable to control the distribution of electrical power to the plurality of LEDs; and
- a pivotable hook coupled to the second end of the housing, the pivotable hook configured to pivot with respect to the second end of the housing;

wherein the light passing through the lens has a range of between 3500 and 5500 lumens.

12. The area light of claim 11, wherein each of the plurality of arms has a plurality of fins, and wherein the one or more LEDs are arranged on a side of the heat sink opposite the housing.

13. The area light of claim 12, wherein the one or more LEDs are selected to emit light with a color rendering index between 50 and 100.

14. The area light of claim 13, wherein light passing through the lens has a temperature that is between 3500 and 4100 Kelvin.

15. The area light of claim 14, further comprising a battery selectively coupled to the housing and arranged to provide power to the one or more LEDs to allow for the emission of light at a level of at least 5700 lumens for at least two hours.

16. The area light of claim 15, wherein the battery is a power tool battery pack that is removable from the housing without disassembly of the housing.

17. The area light of claim 16, wherein the light assembly is configured to emit light through the lens in a direction that is parallel to the central axis.

18. The area light of claim 17, further comprising a control unit operable to control the distribution of electrical power to the one or more LEDs.

19. The area light of claim 18, wherein the control unit is configured to store an intensity level of the one or more LEDs when the light assembly is powered on and off, such that the light assembly may be turned on and off while maintaining the most recent intensity level of the one or more LEDs.

20. An area light comprising:

- a housing defining a central axis and having a first end and a second end that is opposite the first end;
- a light assembly including a heat sink with a surface and a plurality of arms extending radially outward from the

central axis, the light assembly including one or more LEDs on the surface facing in a direction away from the housing;

a lens coupled to the first end of the housing and covering the light assembly, the lens having a width that tapers in a direction extending away from the first end of the housing;

a port formed on the housing and sized to selectively receive a battery;

a user interface including

- a first control member configured to turn the one or more LEDs on and off, and
- a second control member configured to switch the one or more LEDs between a first intensity and a second intensity that is higher than the first intensity,

a control unit operable to control the distribution of electrical power from the battery to the one or more LEDs, the control unit configured to store an intensity level of the one or more LEDs when the light assembly is powered on and off, such that the light assembly may be turned on and off while maintaining the most recent intensity level of the one or more LEDs; and

a pivotable hook coupled to the second end of the housing, the pivotable hook configured to pivot with respect to the second end of the housing,

wherein the light passing through the lens has a range of between 3500 and 5500 lumens,

wherein the one or more LEDs emit light with a color rendering index between 50 and 100 and

wherein the light passing through the lens has a temperature range that is between 3500 and 4100 Kelvin.

* * * * *