

Oct. 25, 1949.

G. W. LACON
FASTENING FOR CUPBOARDS, CABINETS,
OR OTHER LIKE DOORS

2,486,036

Filed Oct. 25, 1945

2 Sheets—Sheet 1

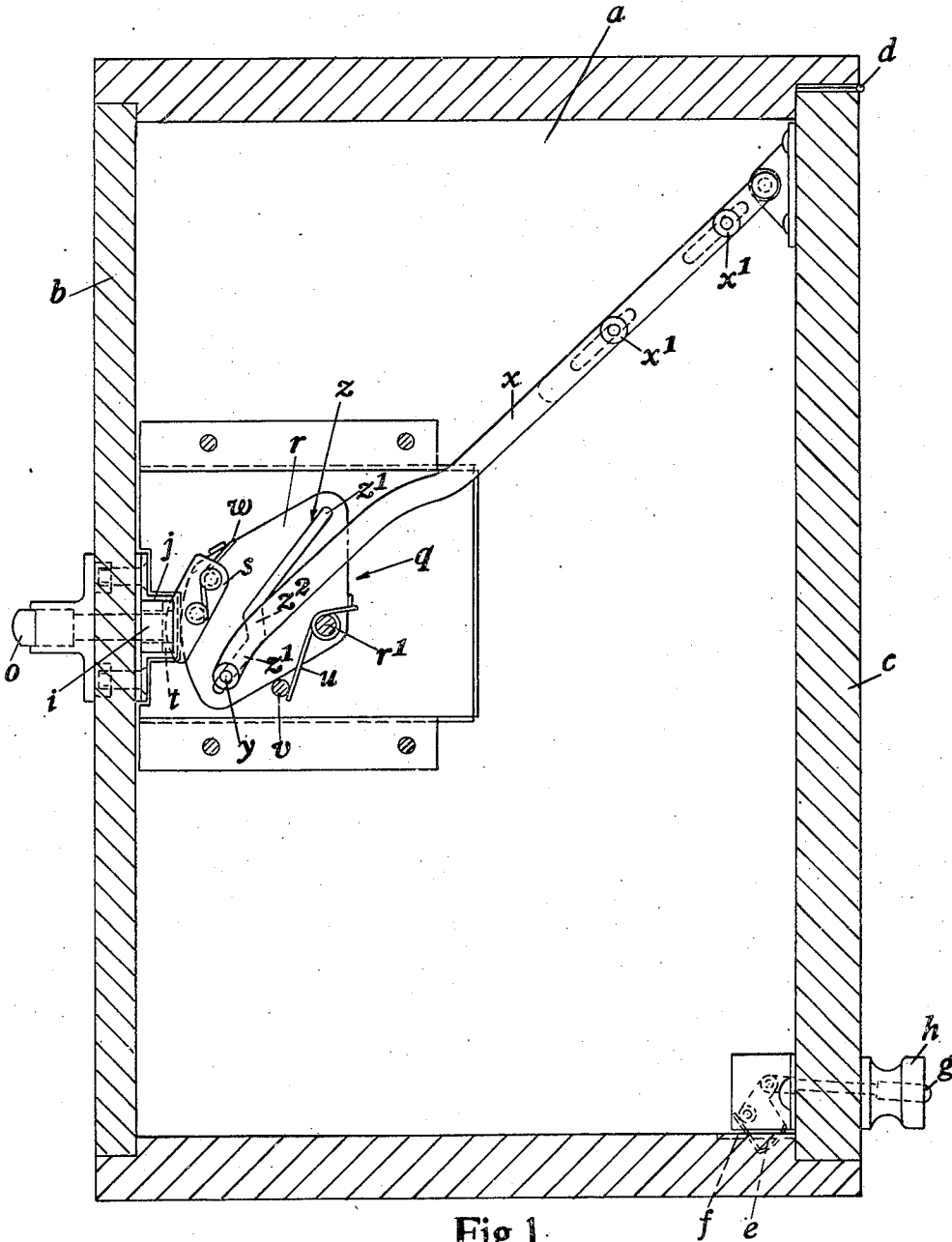

Fig. 1

Inventor
G. W. LACON
By *Glenn Downing* Atty.

Oct. 25, 1949.

G. W. LACON
FASTENING FOR CUPBOARDS, CABINETS,
OR OTHER LIKE DOORS

2,486,036

Filed Oct. 25, 1945

2 Sheets-Sheet 2

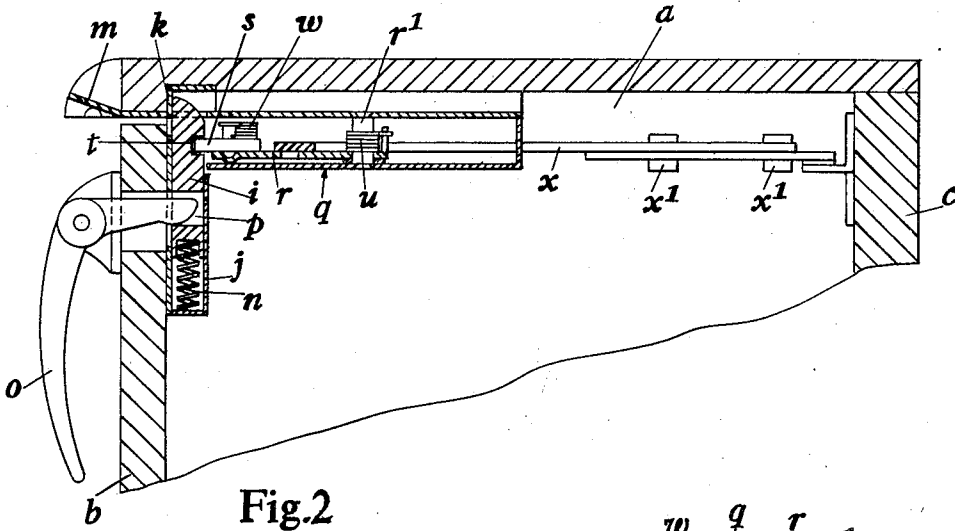

Fig. 2

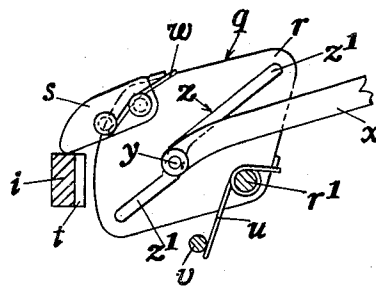

Fig. 3

Inventor
G. W. Lacon
By *Glascock Downing* *Subl*
Atty.

UNITED STATES PATENT OFFICE

2,486,036

FASTENING FOR CUPBOARD, CABINET, OR OTHER LIKE DOORS

Gilbert Whitridge Lacon, Birmingham, England,
assignor of one-third to Wilmot-Breeden Limited,
Birmingham, England, and one-third to
H. Newsum Sons & Company, Limited, Lincoln,
England

Application October 25, 1945, Serial No. 624,369
In Great Britain October 26, 1944

2 Claims. (Cl. 292—146)

1

Some forms of cupboards, cabinets or the like are provided with a pair of oppositely arranged doors. For example, a form of cupboard or cabinet used at the entrance of a dwelling to receive bread, milk or other commodity delivered by a tradesman, is provided at opposite sides with an inner and outer door, the latter being used by the tradesman and the other by the occupant of the dwelling. It is desired that after the tradesman has placed his commodity in the cabinet and closed the door, the latter shall remain locked until the occupant has opened the inner door for the removal of the commodity, the opening of the inner door causing the outer door to be released, and to remain released until it is again re-locked after actuation of the outer door.

The object of the present invention is to enable the above described or other like requirements to be met in a simple and satisfactory manner.

In the accompanying sheets of explanatory drawings:

Figure 1 is a sectional plan, and Figure 2 a fragmentary sectional side view, illustrating the invention applied to a food cabinet.

Figure 3 is a fragmentary sectional plan showing the locking means in its inoperative position.

In the drawings *a* indicates the food cabinet which is adapted to occupy an aperture in the wall of a dwelling, and is intended to receive commodities delivered by a tradesman. The front side of the cabinet *a* is provided with a door *b*, herein termed the outer door, which is hinged at its lower edge (not shown). Also the rear side of the cabinet *a* is provided with another door *c*, herein termed the inner door, which at one of its vertical edges is connected by hinges as *d* to the adjacent side of the cabinet, and which near its other vertical edge carries any convenient fastening for retaining it in its closed position. This fastening may consist as shown of a spring loaded pivotal catch *e* adapted to engage a complementary part *f* on the adjacent side of the cabinet *a*, the catch being operable by an axially movable stem *g* extending through a handle or knob *h* on the inner door *c*.

In carrying the invention into effect as shown, I employ any convenient form of slidable catch *i* which is arranged in a casing *j* adapted to be secured to the inner side of the outer door *b* at

2

a position near its upper edge, and which is adapted to retain this door in its closed position by engaging a shoulder *k* on a striking plate *m* secured to the adjacent part of the cabinet *a*. The catch *i* is movable by a loading spring *n* in the direction for engaging the striking plate *m*, and is retractable by an external handle *o*, the latter having the form of a bell-crank lever which is mounted on the outside of the door *b*, and which at one end extends through openings in this door, and the casing *j* of the catch into a transverse hole *p* in the catch.

For retaining the slidable catch *i* in its operative position, I employ locking means *q* adapted to be mounted on the inner surface of the upper side of the cabinet *a* at a position adjacent to the catch. The locking means *q* comprises a pivotal member *r* in the form of a plate which is pivoted at *r*¹ on a fixed axis, and which carries a pawl *s* adapted by engaging a transverse groove *t* in the catch *i* to retain the latter in its operative position. The pivotal member *r* is loaded by a spring *u* which tends to move the pivotal member into a position in which one of its edges abuts against a fixed stop *v*. Also the pawl *s* is loaded by another spring *w* which is stressed when the pawl engages the groove *t* in the catch *i*. Further I employ for imparting movement to the pivotal member *r* from the inner door *c*, an adjustable link *x* consisting of two parts secured together by bolts *x*¹ passing through holes in one of the link parts and slots in the other, one end of the link being adapted for pivotal attachment to the inner side of the inner door at a position near its hinged edge, and the other end of the link being slidably and pivotally connected to the pivotal member *r* by the engagement of a pin *y* on this end of the link with a slot *z* in the said member. Preferably and as shown the two end portion *z*¹ of the slot *z* are offset from each other and interconnected by an inclined part *z*².

The fastening above described is such that when the outer door *b* is closed and secured by its catch *i* after the inner door *c* has been closed, the pawl *s* occupies the groove *t* in the catch *i* and so prevents actuation of the catch by the external handle *o*, this being the condition shown in Figures 1 and 2. On opening the inner door *c* the link *x* causes the pivotal member *r* to be rocked against the action of its loading spring *u*

3

so as to carry the pawl *s* clear of the catch *i*. When the pawl *s* clears the catch *i* it swings outwardly under the action of its loading spring *w* into a position in which its outer end lies at one side of the catch *i* as shown in Figure 3. When the inner door *c* is subsequently reclosed, the pawl *s* serves by contact with the adjacent side of the catch *i* to prevent the pivotal member *r* from completing its return movement. As the pawl *s* is not now in engagement with the groove *t* in the catch *i*, the outer door *b* is free to be opened by the external handle *o*. On opening the outer door *b* the catch *i* is carried clear of the pawl *s*, and the pivotal member *r* returns under the action of its loading spring *u* to its initial position in which the pawl *s* can re-engage the groove *t* in the catch *i* when the outer door is reclosed.

By this invention I am able to ensure the automatic locking of the outer door of a cabinet of the kind above described in a very simple and satisfactory manner. In some arrangements, two or more such cabinets are mounted one above another, with a separate outer door for each and a common inner door. In this case, the opening of the inner door releases the catches of all the outer doors.

The invention is not, however, limited to the purpose above described as it may be applied to other analogous uses. Also subordinate details of construction or arrangement may be modified to meet different requirements.

Having thus described my invention what I claim as new and desire to secure by Letters Patent is:

4

1. A door fastening having in combination with a slidable catch and actuating means therefor, locking means comprising in combination a spring-loaded pivotal member, a stop against which said pivotal member can bear under the action of its spring loading, means for moving said pivotal member away from said stop, and a spring-loaded pawl on said pivotal member for engaging a transverse groove in and thereby locking said catch in its operative position when said pivotal member bears against said stop, said pawl being arranged to be disengaged from said groove for unlocking said catch in response to movement of said pivotal member away from said stop, and to be prevented by contact with one side of said catch from re-engaging said groove and thereby re-locking said catch until the latter has been first moved by its actuating means clear of said pawl.

2. A door fastening as claimed in claim 1, in which the means for moving the pivotal member away from the stop comprises a link, and means for effect a pivotal and slidable connection between said link and pivotal member.

GILBERT WHITRIDGE LACON.

REFERENCES CITED

The following references are of record in the file of this patent:

UNITED STATES PATENTS

Number	Name	Date
976,261	Hodgkinson	Nov. 22, 1910
1,046,784	Hartman	Dec. 10, 1912

35