



US 20030197041A1

(19) **United States**

(12) **Patent Application Publication**  
West, SR.

(10) **Pub. No.: US 2003/0197041 A1**

(43) **Pub. Date: Oct. 23, 2003**

(54) **INTEGRATED BASE MULTIPLE RIBBON  
PRO BOW WRAPPING DEVICE**

**Publication Classification**

(76) **Inventor: Marvin R. West SR., Oneida, TN (US)**

(51) **Int. Cl.<sup>7</sup> ..... A41H 43/00**

(52) **U.S. Cl. .... 223/46**

Correspondence Address:  
**WILSON ENTERPRISES  
2333 BRIGHTON FARMS BLVD.  
KNOXVILLE, TN 37932 (US)**

(57) **ABSTRACT**

A bow wrapping device having an integrated base adapted to carry a plurality of ribbon spools, vertical posts removably coupled to the base and adapted to retain ribbon fed from the ribbon spools, a rotating peg arm removably coupled to said base, at least one wrapping peg removably coupled to the peg arm, at least one wrapping peg handle removably coupled to the peg arm, wherein said peg arm is adapted to rotate relative to the base and wrap a plurality of ribbons received from the guide retainer in a concentric looped pattern around the wrapping peg and wrapping peg handle.

(21) **Appl. No.: 10/260,895**

(22) **Filed: Sep. 30, 2002**

**Related U.S. Application Data**

(63) **Continuation-in-part of application No. 10/126,800, filed on Apr. 19, 2002.**

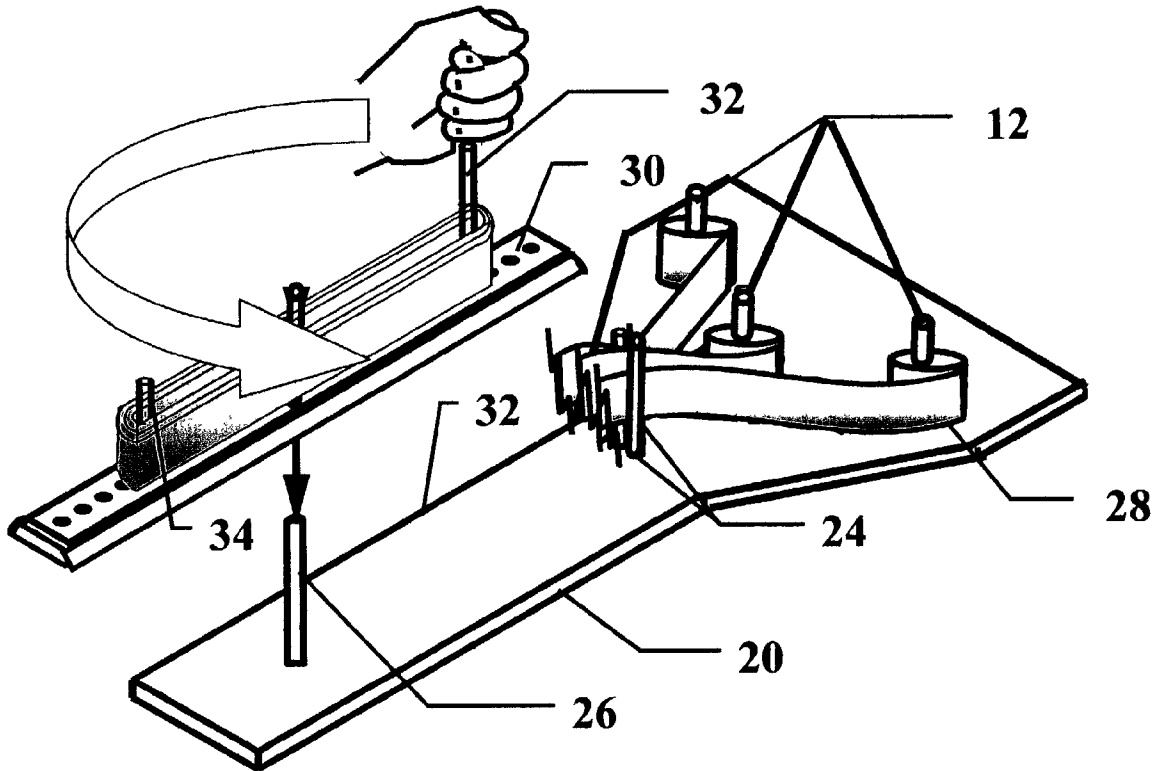

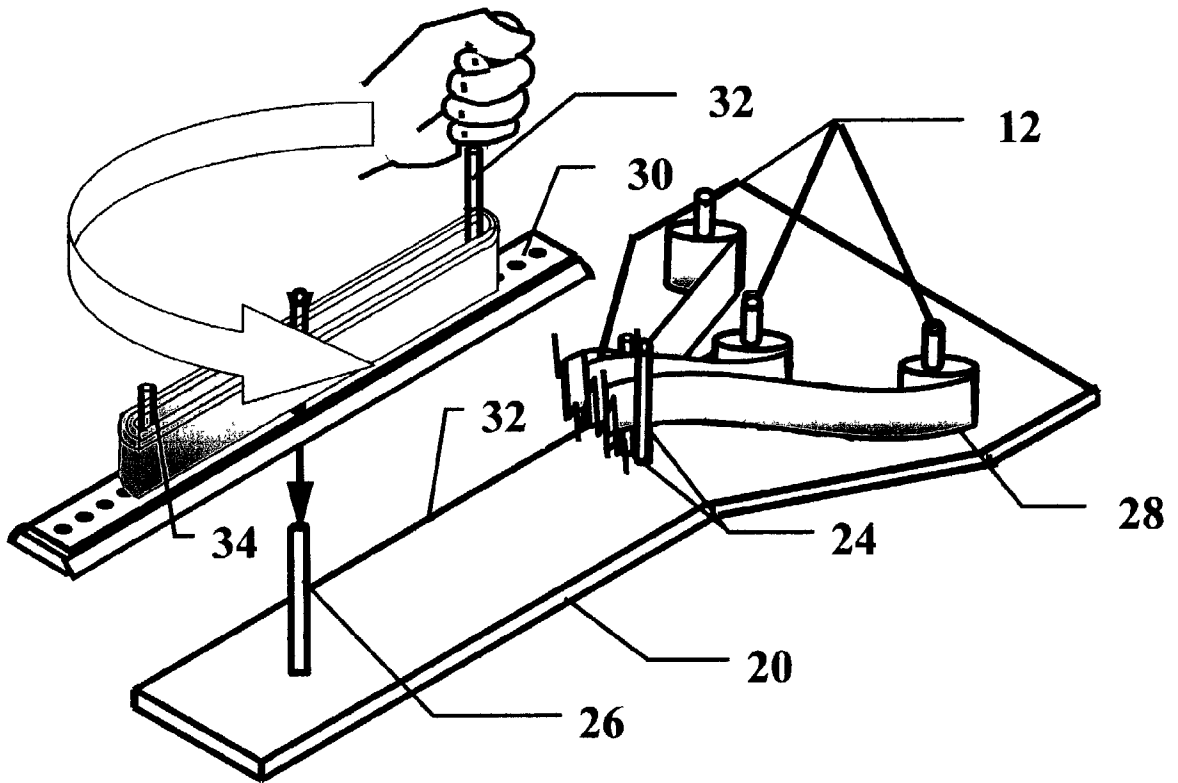

Fig. 1

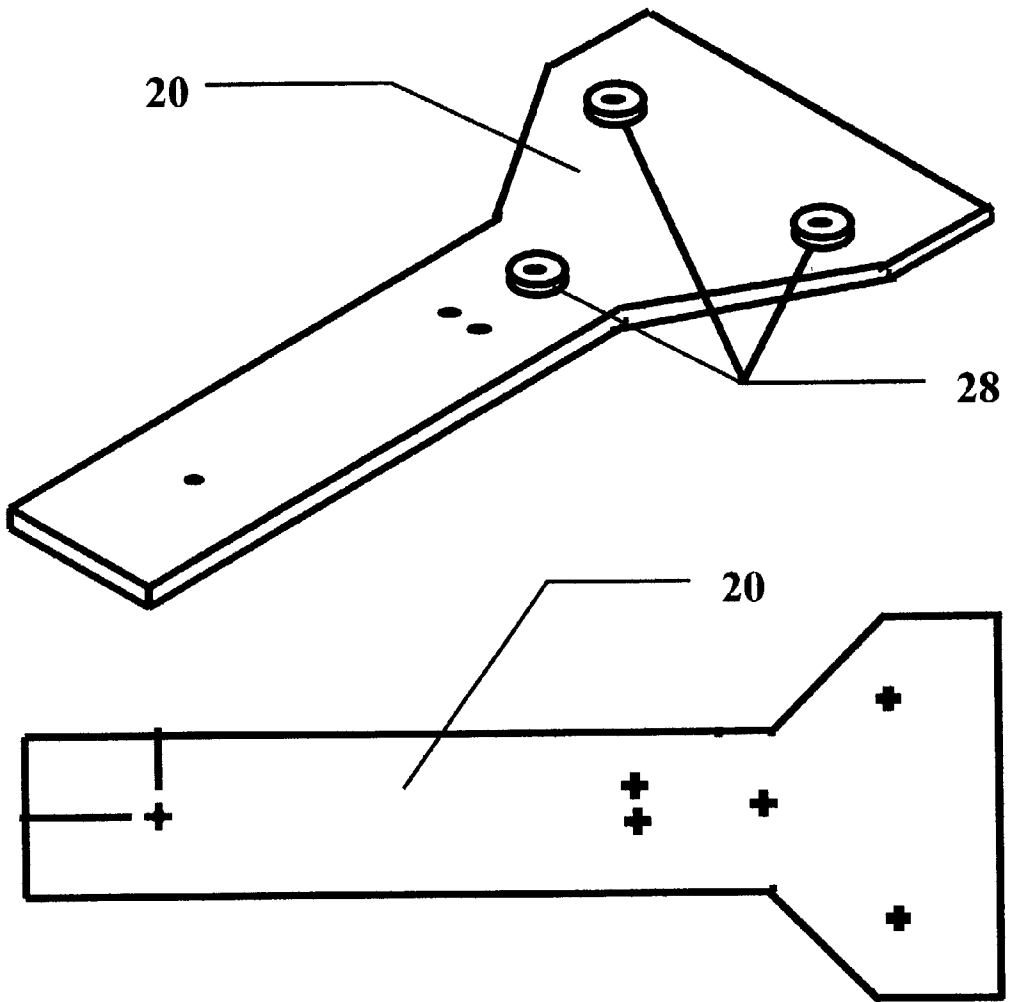

Fig. 2

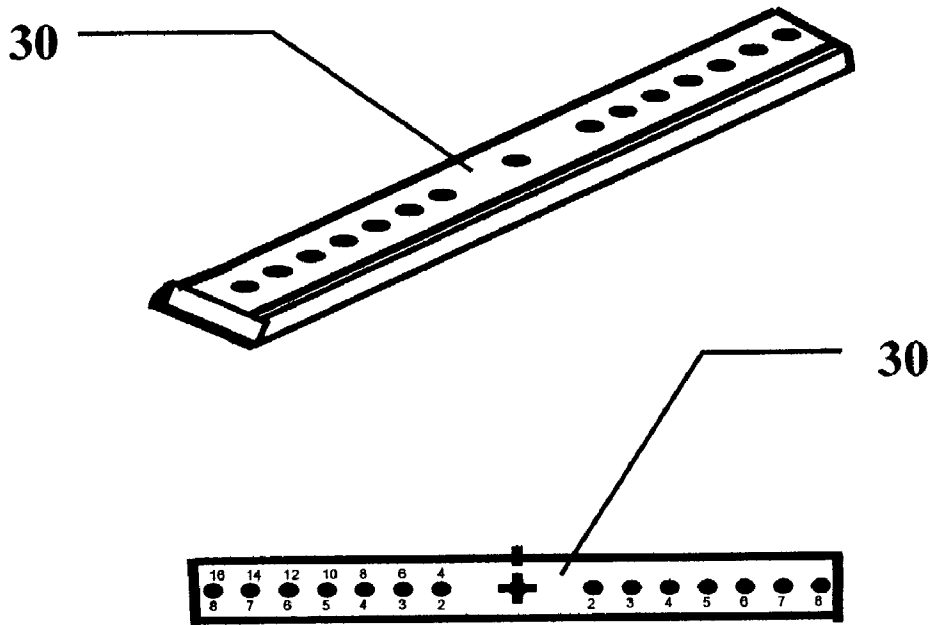

Fig. 3

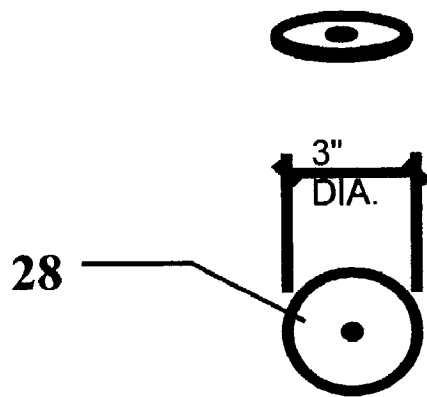

Fig. 4

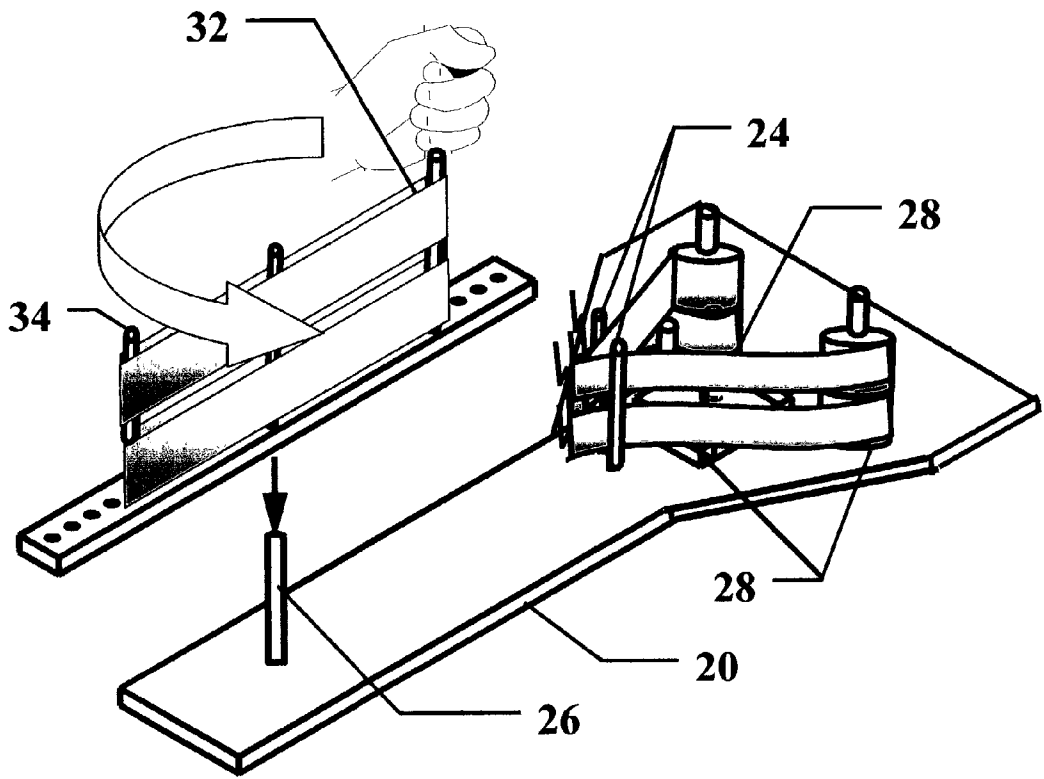

Fig. 5

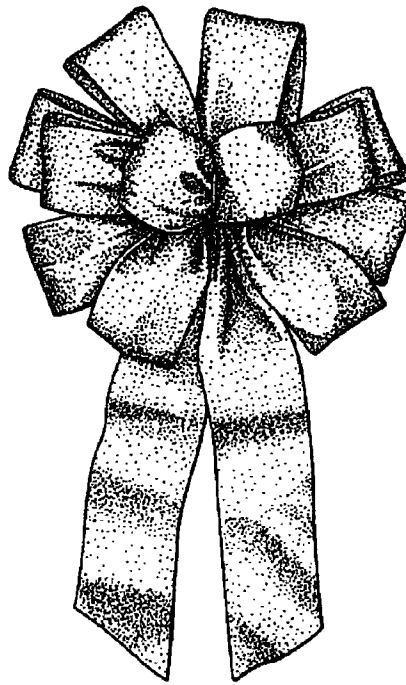

Fig. 6

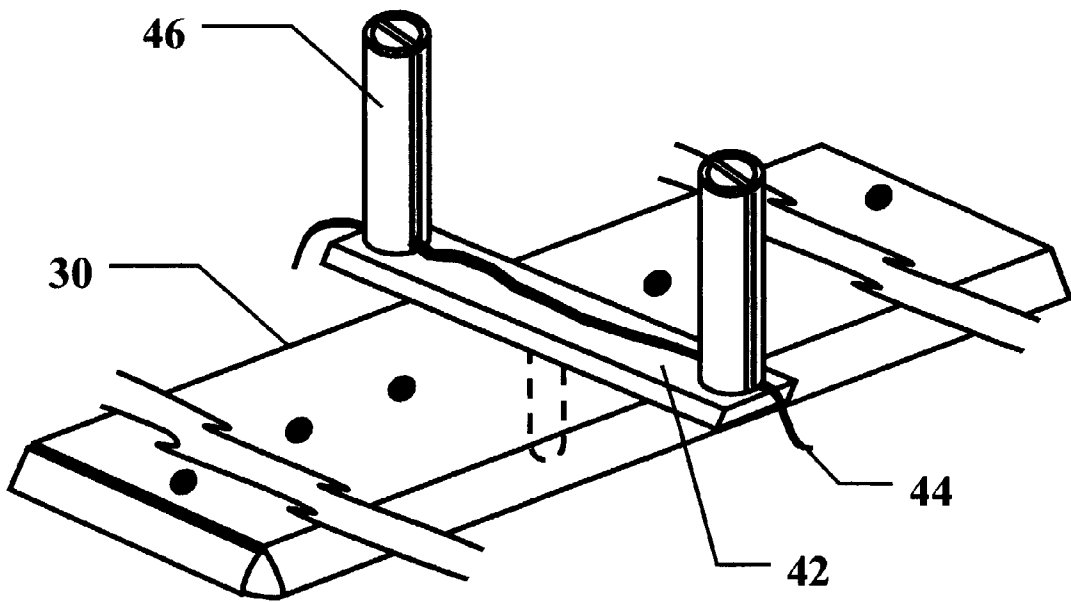

Fig. 7

## INTEGRATED BASE MULTIPLE RIBBON PRO BOW WRAPPING DEVICE

### CROSS REFERENCE TO RELATED APPLICATIONS

[0001] This application is a continuation-in-part of U.S. patent application Ser. No. 10/126,800 filed Apr. 19, 2002.

### FIELD OF THE INVENTION

[0002] This invention is a device to be used in making bows out of ribbon, and is more particularly concerned with a device that wraps single or multiple bows from single or multiple ribbon spools.

### BACKGROUND OF THE INVENTION

[0003] Devices for making bows out of ribbon are common. For example, U.S. Pat. No. 5,810,214, to Hecht, teaches a bow-making device with a substantially rectangular base having a row of circular holes formed in the top surface thereof. The holes are adapted to receive pegs to be mounted on the base in an upright position. At an intermediate point in the row of holes a pair of hoops extends upwardly from the base. In use, a peg is placed in a respective hole on each side of the pair of hoops and a length of ribbon is wound around the pegs to form ribbon loops. The ribbon is passed between the hoops in a position such that the ribbon is held between the pegs by the pair of hoops.

[0004] U.S. Pat. No. 2,666,249, to Ruiz et al., teaches a bow-making device similar to Hecht's, in that Ruiz's jig also includes a row of holes into which pegs may be inserted. Instead of Hecht's pair of hoops, a slotted peg is provided at a central point in Ruiz's row of holes. The slotted peg is intended to constrain the loops of ribbon that are wound around rods on opposite sides of the slotted peg.

[0005] Bow tiers provided according to the prior art generally require the user to manually wrap the ribbon around a stationary portion of the bow and remove the ribbon from pegs having no camber angle. This inventive device improves the bow production process and speed by using a rotating peg arm to form specific sized concentric loops of ribbon that are easily removed from the device and subsequently tied and formed into a decorative bow. The device maintains adequate ribbon tension during wrapping. The wrapping peg boring is drilled into the peg arm at a preselected camber angle to tilt the wrapping peg inward for easy lifting of the wrapped loops of ribbon from the device. Multiple ribbons and bows can be wrapped simultaneously by stacking ribbon spools on the ribbon spool pegs base.

### BRIEF SUMMARY OF THE INVENTION

[0006] According to one aspect of the invention, there is provided a bow wrapping apparatus having a base adapted to carry a plurality of ribbon spools, a guide retainer removably coupled to the base and adapted to retain ribbon fed from the ribbon spools, a peg arm removably coupled to the base, at least one wrapping peg removably coupled to the peg arm, at least one wrapping peg handle removably coupled to the peg arm, wherein said peg arm is adapted to rotate relative to the base and wrap a plurality of ribbons received from the guide retainer in a concentric looped pattern around the wrapping peg and wrapping peg handle.

[0007] It is accordingly an advantage of the invention to provide a bow wrapper that wraps ribbon fed from single or multiple ribbon spools of same or different colored ribbon.

[0008] It is another advantage of the invention to provide a bow wrapper that wraps multiple bows simultaneously. The bows can be the same size or different sizes.

[0009] It is another advantage of the invention to provide a bow wrapper that is useful in making a wide variety of different bow sizes. Incremental wrapping peg holes in the peg arm provide positions for wrapping various sized bows.

[0010] It is another advantage of the invention to provide a bow wrapper that is useful in making a wide variety of different types of bows. A bow can be made with the instant invention using the entire apparatus or by removing the rotating peg arm and using the arm alone for a stationary wrapping station.

### BRIEF DESCRIPTION OF THE DRAWINGS

[0011] FIG. 1 is an unassembled perspective of a bow wrapper provided in accordance with the invention wrapping a single bow with multiple ribbons.

[0012] FIG. 2 is a perspective and plan view of a bow wrapper integrated base provided according to the invention.

[0013] FIG. 3 is a perspective and plan view of a peg arm.

[0014] FIG. 4 is a perspective and plan view of a peg arm mount spacer for height adjustment of ribbon spools.

[0015] FIG. 5 is an unassembled perspective of a bow wrapper provided in accordance with the invention wrapping two bows simultaneously with multiple ribbons.

[0016] FIG. 6 is a plan view of a decorative bow made using the instant invention.

[0017] FIG. 7 is a perspective view of the invention embodiment having a fixed peg arm and tie wire fixture to be used for a manual measuring bow.

### DETAILED DESCRIPTION OF THE INVENTION

[0018] A preferred embodiment of the bow wrapper provided in accordance with the invention will now be described. With reference to FIG. 1, the bow wrapper integrated base 20 serves to mount the components of the bow wrapper and stabilize the apparatus during operation. The integrated base 20 can be either fixed or portable and can be various configurations with any suitable means for stabilization. The integrated base 20 is adapted to carry a plurality of ribbons. Removably coupled to the integrated base 20 is at least one ribbon spool peg 12 that retains spools having different or same color ribbon. The base 20 is integrated with the ribbon spool carriage of the parent patent application thereby forming an integrated base 20.

[0019] The ribbon from each spool, mounted on at least one ribbon spool peg 12, is threaded through a gap between the vertical posts 24 that are removably coupled to the base 20 en route to the rotating peg arm 30.

[0020] The peg arm mount **26** is removably coupled to the integrated base **20** and serves as a central post and rotating axis for removably coupling the rotating peg arm **30** to the base **20**. The peg arm mount **26** also serves as the beginning post to wrap and pin the leading edges of ribbon to prior to starting rotation. The peg arm mount spacer **28** provides clearance between the peg arm **30** and the base **20** during rotation. The mount spacer **28** can also be used on the spool pegs **12** to lift ribbon spools from the base **20**.

[0021] FIG. 3 shows peg arm **30** that is match drilled, or bored, at incremental distances from the center to receive wrapping pegs and facilitate making various bow sizes. Bow sizes in the range of 2 to 16 inches outside diameter can be made with the peg arm **30** shown but extending the length of peg arm **30** can make larger bows. The peg arm borings are only sufficient depth to removably retain and press fit the wrapping peg **34** into the peg arm **30**. Wrapping peg handle **32** borings are slightly oversized to enable the handle to spin inside its respective boring. Wrapping peg **34** borings are made in sizes such that the wrapping peg **34** can be removably coupled to the peg arm **30** in a manner such as press fitting. Perimeter edges of peg arm **30** are rounded or slanted to prevent snagging the ribbon during rotation.

[0022] In accordance with the illustrations, the bow wrapping operation is started by assembling all components of the bow wrapper onto a stable support that will prevent unnecessary movement of the bow wrapper during operation. The integrated base **20** is then loaded with at least one ribbon spool of a preselected color and material. If multiple spools are desired, additional spools of varying or similar color material can be loaded and threaded through the vertical posts **24** before being removably pinned to the peg arm mount **26** as a starting hold. Wrapping peg **34** and wrapping peg handle **32** are then inserted into their respective borings at the desired bow size as marked on peg arm **30**. It is also possible to wrap using only the peg arm mount **26** and the wrapping peg handle **32** when smaller bows are desired. The peg arm **30** is then rotated around the peg arm mount **26** axis a sufficient number of times to create the number of concentric loops desired in the bow. For example, if a 12-inch diameter bow is desired, the wrapping peg handle **32** and the wrapping peg **34** are placed in the peg borings marked "6" which signifies 6 inches from center. The peg arm **30** is then rotated twelve full revolutions for a single ribbon feed and twelve concentric loops of ribbon are formed. Rotation of the peg arm **30** is stopped and the wrapped ribbon is carefully lifted intact from the wrapping pegs. While intact, the concentric loops are folded once along the central axis vacated by the peg arm mount **26**. Holding the ribbon in the folded position, the two ribbon corners formed along the fold axis are clipped at an angle to remove excess ribbon from the tying area and to provide a narrowed ribbon center seam for placement of a tie wire. A tie wire or similar tying material is then wrapped around the narrowed ribbon center seam and twisted onto itself to secure the center seam. Individual loops originating from the center seam are then spread apart and twisted in an organized fashion then positioned relative to each other to make a decorative bow as seen in FIG. 6. The preferred appearance of the decorative bow is formed when wrapping is performed in accordance with the following table:

Bow Diameter (inches)	Wrapping				
	Wrapping Peg Position	Peg Handle Position	Single Ribbon Feed	Dual Ribbon Feed	Triple Ribbon Fee
2	N/A	2	2	1	N/A
4	2	2	4	2	1
6	3	3	6	3	2
8	4	4	8	4	2.5
10	5	5	10	5	3
12	6	6	12	6	4
14	7	7	14	7	4.5
16	8	8	16	8	5

[0023] FIG. 5 shows an embodiment of the instant invention wherein two separate bows are wrapped simultaneously using stacked ribbon spools on the ribbon spool pegs. Each bow is constructed in the same manner as a single bow. Each bow is lifted from the device separately and then tied and formed as individual bows.

[0024] The bows being wrapped in FIG. 5 are the same diameter but different diameter bows can be wrapped by elevating the rotating peg arm **30** on the peg arm mount **26** such that one bow is wrapped on the upper side the rotating peg arm **30** and a second bow is wrapped on the under side of the rotating peg arm **30**. Additional wrapping pegs (not shown) must be removably coupled to the under side of the elevated rotating peg arm **30** and these wrapping pegs can be positioned different from those on the upper side of the rotating peg arm **30** thereby enabling different size bows to be wrapped simultaneously.

[0025] Another embodiment of the invention, shown in FIG. 7, uses the rotating peg arm **30** in a stationary mode as a stand-alone arm for manual wrapping. This embodiment is used in the same manner as taught in U.S. Pat. No. 6,000, 586, which is herein incorporated by reference. In this embodiment, the tie wire fixture **42** is removably coupled to the stationary peg arm **30** using the hole vacated by the peg arm mount **26**. When wrapping bows in this embodiment, the wrapping peg **34** and the wrapping peg handle **32** are removed and the incremental measurements on the peg arm **30** are used to manually loop and overlay the ribbon flat onto the peg arm **30** at a preselected length while gathering the center of the bow between the tie wire fixture posts **46** for tying. A tie wire **44** is positioned into slots of the tie wire fixture posts **46** prior to wrapping such that when wrapping is complete, the ribbon laying between tie wire fixture posts **46** can be easily gathered and secured with tie wire **44**.

[0026] According to a preferred embodiment of the invention, all components of the bow wrapper are made of wood. However, other materials may be used. For example, all of the components may be formed of plastic, polypropylene, hard rubber, metal or any other material that has a degree of natural elasticity.

[0027] It should further be understood that no particular ribbon-securing mechanism is essential to the invention. For example, the wrapping pegs may be arranged to be hollow cylinders, open at least at one end, and the ribbon-securing mechanism may include a clip shaped like a bobby-pin or a

paper clip which may be slidingly engaged with the wall of the hollow peg, to secure the ribbon loop at the outer surface of the peg wall.

[0028] The wrapping pegs shown herein are substantially cylindrical, but pegs having a non-circular cross-section, such as square or rectangular may be used. Of course, the peg arm holes should have a shape that is matched to the cross-section of the pegs.

[0029] The removably coupled wrapping pegs shown herein function as members around which the ribbon is wound during a bow-making operation. However, instead of removably coupled pegs, the present invention may be constructed with uprights which are fixedly mounted in the peg arm and which have ribbon-holding means such as the clips described herein. For example, wooden pegs may be permanently mounted in holes in the peg arm by means of glue or the like. Alternatively, the peg arm and upright members may be integrally formed as a single body of molded plastic.

[0030] It is expected that bow-makers would achieve a higher rate of production and higher quality bows using the instant invention. The bow wrapping device maintains adequate tension on the ribbons during production and provides for multiple ribbon feeds. Multiple bows can be wrapped simultaneously by stacking ribbon spools on the ribbon spool pegs.

[0031] Various changes to the foregoing device may be introduced without departing from the invention. The particularly preferred apparatus described herein is thus intended in an illustrative and not limiting sense. The true spirit and scope of the invention are set forth in the following claims.

What is claimed is:

1. A bow wrapping device, comprising;
  - a base adapted to carry a plurality of ribbon spools,
  - vertical posts removably coupled to said base and adapted to retain ribbon fed from said ribbon spools,
  - a peg arm mount removably coupled to said base,
  - a peg arm removably coupled to said peg arm mount,
  - at least one wrapping peg removably coupled to said peg arm,
  - at least one wrapping peg handle removably coupled to said peg arm,
  - wherein said peg arm is adapted to rotate relative to said base and wrap a plurality of ribbons received from said guide retainer in a concentric looped pattern around said wrapping peg and said wrapping peg handle.
2. The bow wrapping device of claim 1 wherein said base is fixed or portable.
3. The bow wrapping device of claim 1 wherein the outside diameter of bows made with said device is in the range of approximately 2 to 16 inches.
4. The bow wrapping device of claim 1 wherein the perimeter edges of said peg arm are rounded or slanted.
5. The bow wrapping device of claim 1 wherein said spool pegs, vertical posts, peg arm mount, wrapping pegs, and wrapping peg handle are elongated for simultaneously wrapping multiple bows.

6. The bow wrapping device of claim 1 constructed from material selected from the group consisting of wood, plastic, polypropylene, hard rubber, and metal.

7. A bow wrapping device, comprising;

a base adapted to carry a plurality of ribbon spools,  
vertical posts removably coupled to said base and adapted to retain ribbon fed from said ribbon spools,

a tie wire fixture removably coupled to said base,

a peg arm removably coupled to said tie wire fixture,

wherein said peg arm is in a fixed position to manually loop and overlay a plurality of ribbons received from said guide retainer in a flat stacking pattern.

8. The bow wrapping device of claim 7 wherein said base is fixed or portable.

9. The bow wrapping device of claim 7 wherein the outside diameter of bows made with said device is in the range of approximately 2 to 22 inches.

10. The bow wrapping device of claim 7 constructed from material selected from the group consisting of wood, plastic, polypropylene, hard rubber, and metal.

11. A method of making a bow comprising the steps of;

loading multiple ribbon spools onto a base,

threading ribbons from said ribbon spools through a guide retainer,

pinning said ribbons to a peg arm mount,

press fitting a wrapping peg and wrapping peg handle into said peg arm at a preselected position for a preselected bow size,

rotating said peg arm around the peg arm mount axis sufficient revolutions to form the number of concentric loops necessary for said preselected bow size,

lifting the intact concentric loops from said wrapping peg and wrapping peg handle,

folding said intact concentric loops along a fold axis vacated by said peg arm mount,

clipping excess ribbon along the two ribbon corners at the fold axis thereby forming a narrowed ribbon center seam,

tying the concentric loops together at said narrowed ribbon center seam,

spreading apart and twisting said concentric loops in an organized fashion,

positioning said loops relative to each other to form a decorative bow.

12. The method of claim 11 wherein the outside diameter of the bow is in the range of approximately 2 to 16 inches.

13. The method of claim 11 wherein said ribbon spools are stacked to wrap at least two concentric loops simultaneously.