

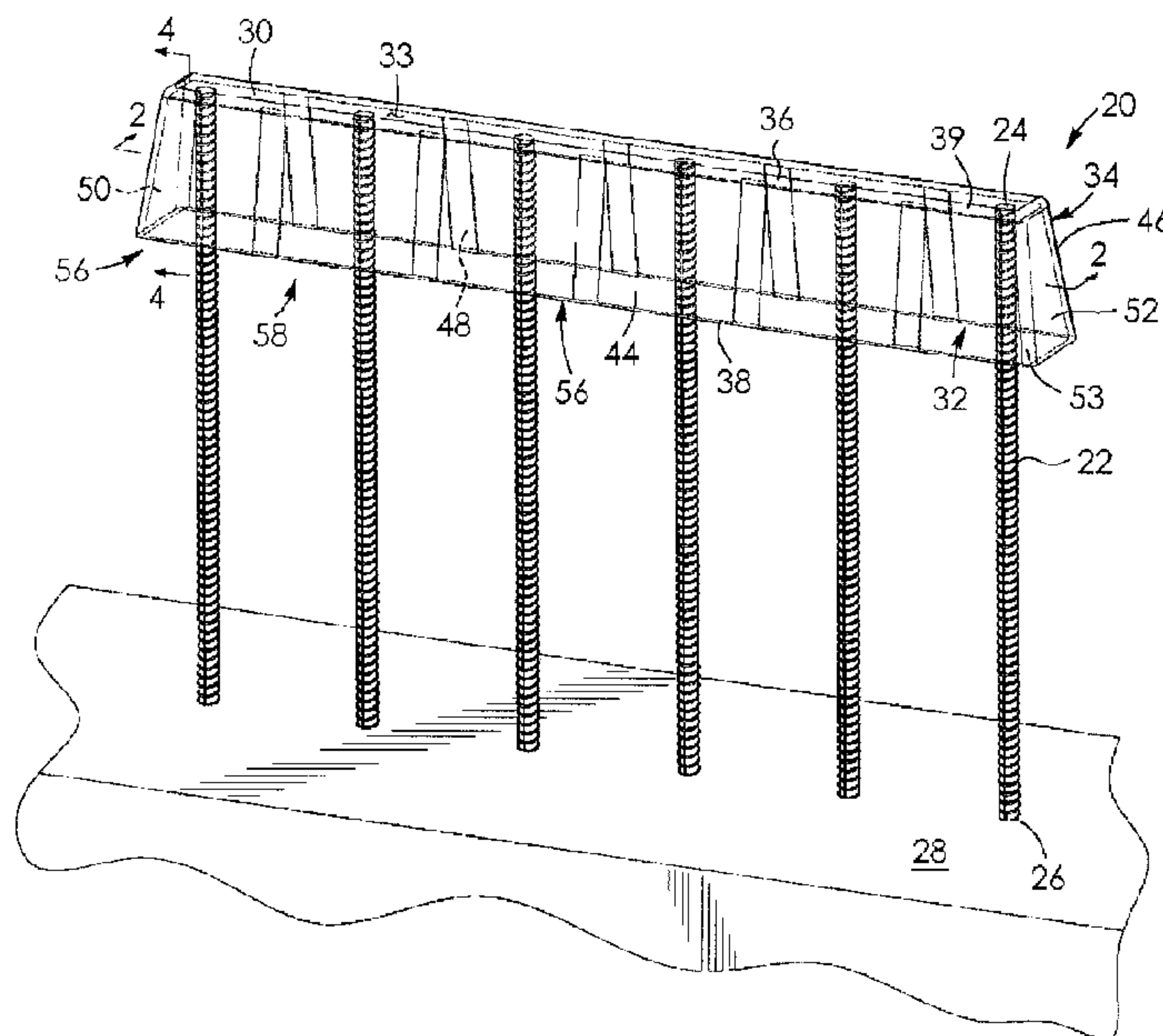

(86) Date de dépôt PCT/PCT Filing Date: 2014/11/03  
 (87) Date publication PCT/PCT Publication Date: 2015/05/07  
 (45) Date de délivrance/Issue Date: 2018/03/13  
 (85) Entrée phase nationale/National Entry: 2017/01/10  
 (86) N° demande PCT/PCT Application No.: CA 2014/051054  
 (87) N° publication PCT/PCT Publication No.: 2015/061913  
 (30) Priorité/Priority: 2013/11/04 (US14/071,389)

(51) Cl.Int./Int.Cl. *E04C 5/16* (2006.01),  
*E04G 21/32* (2006.01)  
 (72) Inventeurs/Inventors:  
HEWLETT, PHIL, CA;  
MACLEAN, JIM, CA  
 (73) Propriétaire/Owner:  
0971065 B.C. LTD., CA  
 (74) Agent: CAMERON IP

(54) Titre : APPAREIL ANTI-EMPALEMENT DESTINE A S'ETENDRE AU-DESSUS ET AUTOUR DES EXTREMITES EXPOSEES D'UNE PLURALITE DE BARRES DE RENFORCEMENT ESPACEES  
 (54) Title: IMPALEMENT PREVENTION APPARATUS FOR EXTENDING OVERTOP OF AND AROUND THE EXPOSED ENDS OF A PLURALITY OF SPACED-APART REINFORCING BARS



(57) **Abrégé/Abstract:**

There is provided an impalement prevention apparatus for use with a plurality of spaced- part bars. The apparatus includes an elongate top portion shaped to extend overtop of exposed ends of the bars. The apparatus includes a pair of elongate spaced-apart side portions connecting to the top portion and extending downwards therefrom. The apparatus includes a pair of spaced-apart end portions each connecting to and extending between the side portions. The top portion, the side portions and the end portions form an enclosure extendable around the exposed ends of the bars.

(12) INTERNATIONAL APPLICATION PUBLISHED UNDER THE PATENT COOPERATION TREATY (PCT)

(19) World Intellectual Property  
Organization  
International Bureau(43) International Publication Date  
7 May 2015 (07.05.2015)(10) International Publication Number  
**WO 2015/061913 A1**

## (51) International Patent Classification:

*E04C 5/16* (2006.01) *E04G 21/32* (2006.01)

## (21) International Application Number:

PCT/CA2014/051054

## (22) International Filing Date:

3 November 2014 (03.11.2014)

## (25) Filing Language:

English

## (26) Publication Language:

English

## (30) Priority Data:

14/071,389 4 November 2013 (04.11.2013) US

(71) Applicant: **0971065 B.C. LTD.** [CA/CA]; 8013 Modesto Drive, Delta, British Columbia V4C 4A9 (CA).(72) Inventors: **HEWLETT, Phil**; 8013 Modesto Drive, Delta, British Columbia V4C 4A9 (CA). **MACLEAN, Jim**; 8013 Modesto Drive, Delta, British Columbia V4C 4A9 (CA).(74) Agent: **CAMERON IP**; 1401-1166 Alberni Street, Vancouver, British Columbia V6E 3Z3 (CA).

## (81) Designated States (unless otherwise indicated, for every kind of national protection available): AE, AG, AL, AM, AO, AT, AU, AZ, BA, BB, BG, BH, BN, BR, BW, BY, BZ, CA, CH, CL, CN, CO, CR, CU, CZ, DE, DK, DM,

DO, DZ, EC, EE, EG, ES, FI, GB, GD, GE, GH, GM, GT, HN, HR, HU, ID, IL, IN, IR, IS, JP, KE, KG, KN, KP, KR, KZ, LA, LC, LK, LR, LS, LU, LY, MA, MD, ME, MG, MK, MN, MW, MX, MY, MZ, NA, NG, NI, NO, NZ, OM, PA, PE, PG, PH, PL, PT, QA, RO, RS, RU, RW, SA, SC, SD, SE, SG, SK, SL, SM, ST, SV, SY, TH, TJ, TM, TN, TR, TT, TZ, UA, UG, US, UZ, VC, VN, ZA, ZM, ZW.

## (84) Designated States (unless otherwise indicated, for every kind of regional protection available): ARIPO (BW, GH, GM, KE, LR, LS, MW, MZ, NA, RW, SD, SL, ST, SZ, TZ, UG, ZM, ZW), Eurasian (AM, AZ, BY, KG, KZ, RU, TJ, TM), European (AL, AT, BE, BG, CH, CY, CZ, DE, DK, EE, ES, FI, FR, GB, GR, HR, HU, IE, IS, IT, LT, LU, LV, MC, MK, MT, NL, NO, PL, PT, RO, RS, SE, SI, SK, SM, TR), OAPI (BF, BJ, CF, CG, CI, CM, GA, GN, GQ, GW, KM, ML, MR, NE, SN, TD, TG).

## Declarations under Rule 4.17:

- as to the identity of the inventor (Rule 4.17(i))
- as to applicant's entitlement to apply for and be granted a patent (Rule 4.17(ii))
- as to the applicant's entitlement to claim the priority of the earlier application (Rule 4.17(iii))

[Continued on next page]

## (54) Title: IMPALEMENT PREVENTION APPARATUS FOR EXTENDING OVERTOP OF AND AROUND THE EXPOSED ENDS OF A PLURALITY OF SPACED-APART REINFORCING BARS

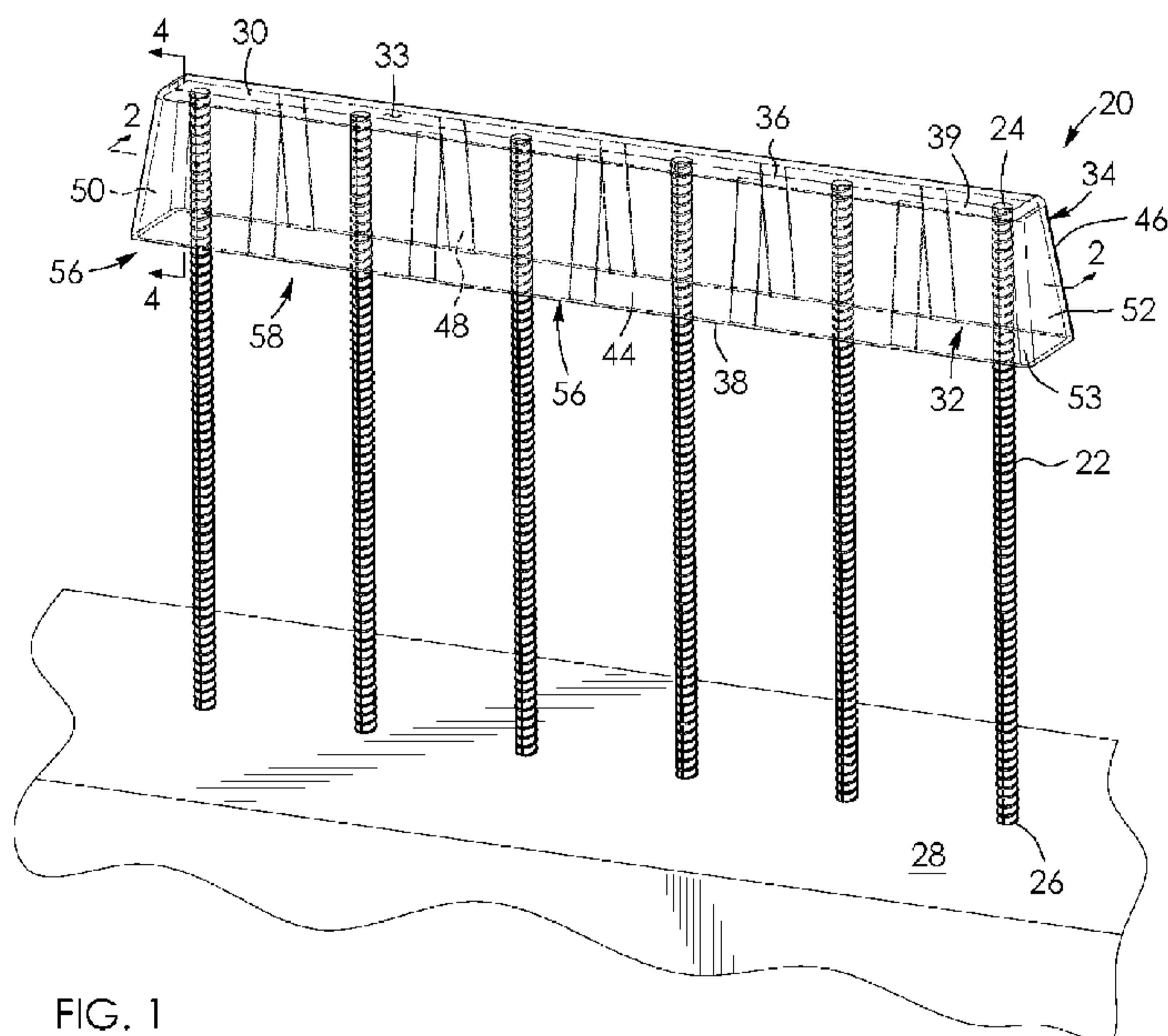

FIG. 1

(57) Abstract: There is provided an impalement prevention apparatus for use with a plurality of spaced-apart bars. The apparatus includes an elongate top portion shaped to extend overtop of exposed ends of the bars. The apparatus includes a pair of elongate spaced-apart side portions connecting to the top portion and extending downwards therefrom. The apparatus includes a pair of spaced-apart end portions each connecting to and extending between the side portions. The top portion, the side portions and the end portions form an enclosure extendable around the exposed ends of the bars.

**WO 2015/061913 A1** 

---

**Published:**

— *with international search report (Art. 21(3))*

— *before the expiration of the time limit for amending the claims and to be republished in the event of receipt of amendments (Rule 48.2(h))*

**IMPALEMENT PREVENTION APPARATUS  
FOR EXTENDING OVERTOP OF AND AROUND THE EXPOSED ENDS OF A  
5 PLURALITY OF SPACED-APART REINFORCING BARS**

Field of the Invention

[0001] There is provided an impalement prevention apparatus. In particular, there is provided an impalement prevention apparatus for extending overtop of and around the exposed ends of a plurality of spaced-apart bars.  
10

Description of the Related Art

[0002] United States Patent No. 5,950,680 to Randall discloses an impalement protector for use in shielding protruding concrete reinforcing bars, typically found on construction sites. The impalement protector is used to prevent personal injuries caused by persons falling or otherwise coming into contact with the tips of the reinforcing bars. The impalement protector consists of an elongated U-shaped channel that is formed such that the free ends thereof are drawn together such that the impalement protector slides over the reinforcing bars, creating a friction fit therewith and securing itself thereto.  
15

[0003] The above-described prior art may suffer from a number of disadvantages. The majority of people who fall at constructions sites may fall within a distance of ten vertical feet, and thus at an angle relative to the vertical axis. People who fall are thus more likely than not to fall at an angle. When said people fall onto the above-described device at an angle, the device may have a tendency to slide and expose the ends of the bars, thereby increasing the risk of impalement.  
20  
25

[0004] The above-described device may be relatively bulky for storage purposes and may be cumbersome to extend overtop of the bars.

[0005] There is accordingly a need for an improved impalement prevention device.

### BRIEF SUMMARY OF INVENTION

[0006] There is provided an impalement prevention apparatus disclosed herein that overcomes the above disadvantages.

5 [0007] There is accordingly provided an impalement prevention apparatus for use with a plurality of spaced-part bars. The apparatus includes an elongate top portion shaped to extend overtop of exposed ends of the bars. The apparatus includes a pair of elongate spaced-apart side portions connecting to the top portion and extending downwards therefrom. The apparatus includes a pair of spaced-apart end portions each  
10 connecting to and extending between the side portions. The top portion, the side portions and the end portions form an enclosure extendable around the exposed ends of the bars.

[0008] There is also provided an impalement prevention apparatus for use with a plurality of spaced-part bars. The apparatus includes a means for forming an enclosure extendable around the exposed ends of the bars.

15

### BRIEF DESCRIPTION OF DRAWINGS

[0009] The invention will be more readily understood from the following description of preferred embodiments thereof given, by way of example only, with reference to the accompanying drawings, in which:

20 Figure 1 is a top, side perspective view of an impalement prevention apparatus according to one aspect, shown extending around and overtop of the exposed ends of a plurality of spaced-apart bars;

Figure 2 is a sectional view taken along lines 2 – 2 of the apparatus of Figure 1;

Figure 3 is a bottom plan view of the apparatus of Figure 1;

Figure 4 is a sectional view taken along lines 4 – 4 of the apparatus of Figure 1;

5

Figure 5 is a sectional view similar to Figure 4 of a plurality of impalement prevention apparatuses shown stacked together, each of the apparatuses being of the type shown in Figure 1;

10 Figure 6 is a side elevation view of an impalement prevention apparatus according to a second aspect, shown extending around and overtop of the exposed ends of a plurality of spaced-apart bars;

Figure 7 is a sectional view similar to Figure 5 of a plurality of impalement prevention apparatuses shown in sectional view and shown stacked together, each of the apparatuses being of the type shown in Figure 6;

15

Figure 8 is a top, side perspective view of an impalement prevention apparatus according to a third aspect, shown extending around and overtop of the exposed ends of a plurality of spaced-apart bars;

20

Figure 9 is a sectional view similar to Figure 5 of a plurality of impalement prevention apparatuses shown in section and shown stacked together, each of the apparatuses being of the type shown in Figure 8;

25

Figure 10 is a top, side perspective view of an impalement prevention apparatus according to a fourth aspect;

Figure 11 is an enlarged top plan view of part of the top portion of the apparatus of Figure 10;

30

Figure 12 is a bottom, side perspective view of the apparatus of Figure 10, the apparatus being partially broken away;

5 Figure 13 is an enlarged bottom plan view of part of the top portion of the apparatus of Figure 10;

Figure 14 is a cross-sectional view of the apparatus of Figure 10 taken along lines 14 – 14 of the apparatus of Figure 10;

10 Figure 15 is a side-sectional view of the apparatus of Figure 10 taken along lines 15 – 15 of the apparatus of Figure 10;

Figure 16 is a cross-sectional view similar to Figure 14 of an impalement prevention apparatus according to a fifth aspect;

15

Figure 17 is a side-sectional view similar to Figure 15 of the apparatus of Figure 16; and

Figure 18 is a cross-sectional view similar to Figure 16 of an impalement prevention apparatus according to a sixth aspect.

20

#### DESCRIPTION OF THE PREFERRED EMBODIMENTS

[0010] Referring to the drawings and first to Figure 1, there is shown an impalement prevention apparatus 20 for use with a plurality of spaced-part reinforcing bars 22 for concrete construction. Each bar has an exposed end 24 and a proximal end 26 which is spaced-apart from the exposed end. The proximal ends of the reinforcing bars are connected to a foundation, in this example a concrete foundation 28. The exposed ends 24 of the bars 22 are spaced-apart from the foundation.

[0011] The apparatus 20 is made of recycled plastic in this example, though this is not strictly required. The apparatus is made of polyethylene accordingly to one preferred aspect, though the apparatus can be made of other materials in other embodiments.

[0012] The apparatus 20 is in the form of a hollow housing and includes an elongate top portion 30 shaped to extend overtop of the exposed ends 24 of the reinforcing bars 22. The top portion is rectangular in shape in this example and has an inner surface 31 and an outer surface 33 spaced-apart from its inner surface. The apparatus 20 includes a pair of elongate spaced-apart side portions 32 and 34. The side portions are isosceles trapezoids in shape in this example. Each of the side portions of the apparatus has a proximal end and a distal end spaced-apart from the proximal end, as shown by proximal end 36 and distal end 38 for side portion 32. The proximal ends of the side portions 32 and 34 connect to the top portion 30 of the apparatus 20 and extend downwards therefrom towards the proximal ends 26 of the reinforcing bars 22. The side portions of the apparatus connect to the top portion of the apparatus via rounded corners in this example, as shown by rounded corner 39 extending along and between side portion 32 and top portion 30 in Figure 4.

[0013] As best seen in Figure 4, each of the side portions 32 and 34 of the apparatus 20 connects to and extends outwards from the top portion 30 thereof at an obtuse angle  $\alpha$  relative to the top portion in this example. Angles  $\alpha$  are equal to each other in absolute value in this example and are equal to 100 degrees in this example. However, this is not strictly required and the angles may be other values in other embodiments.

[0014] The side portions 32 and 34 of the apparatus 20 have inner surfaces 40 and 42, respectively, which face each other. The side portions of the apparatus have outer surfaces 44 and 46, respectively, which are spaced-apart from the inner surfaces.

[0015] The apparatus 20 includes a plurality of stacking spacers, in this example, elongate strips 48. The strips are rectangular prisms in shape in this example. The strips 48 are connected to and spaced-apart along respective ones of the inner surfaces 40 and

42 of the side portions 32 and 34 of the apparatus. Each strip extends from a respective one of the proximal ends of the side portions to a respective one of the distal ends of the side portions, as shown in Figure 4 by strip 48 extending between ends 36 and 38 of side portion 32 of the apparatus 20. As seen in Figure 1, the strips 48 are positioned to be  
5 interposable between respective ones of the reinforcing bars. The strips 48 provide spacing between respective side portions of a plurality of apparatuses 20 when the apparatuses are stacked together, as seen in Figure 5. Thus, when the apparatuses are wet, the strips inhibit the apparatuses so stacked from sticking together.

[0016] Referring back to Figure 1, apparatus 20 includes a pair of spaced-apart end  
10 portions 50 and 52 each connecting to and extending between the side portions 32 and 34 thereof. The end portions are isosceles trapezoids in shape in this example, as best seen in Figure 4 for end portion 50. The end portions of the apparatus 20 connect to the side portions of the apparatus via rounded corners, as shown by rounded corner 53 extending along and between end portion 52 and side portion 32 in Figure 1.

15 [0017] Referring to Figure 2, each of the end portions 50 and 52 of the apparatus 20 connects to and extends outwards from the top portion 30 of the apparatus at an obtuse angle  $\beta$  relative to the top portion in this example. Angles  $\beta$  are equal to each other in absolute value in this example. Angle  $\beta$  is equal to 100 degrees in this example, though  
20 this is not strictly required and may be a different value in other embodiments. The end portions of the apparatus 20 connect to the top portion of the apparatus via rounded corners, as shown by rounded corner 54 extending along and between end portion 50 and top portion 30 in Figure 2.

[0018] As seen in Figure 1, the apparatus 20 includes an open end 56 spaced-apart  
25 from the top portion 30. The open end is rectangular in shape in this example and is larger than the top portion in this example. The apparatus 20 is tapered from the open end 56 towards the top portion thereof. The top portion 30, the side portions 32 and 34 and the end portions 50 and 52 of the apparatus form an enclosure 58 which is extendable around the exposed ends 24 of the reinforcing bars 22. The end portions of the apparatus

20 are shaped to abut adjacent ones of the reinforcing bars when a person falls onto the apparatus at an angle. This may thereby ensure that the apparatus remains extended overtop of and around the exposed ends of the reinforcing bars. The apparatus 20 so shaped, with its rounded corners and outwardly protruding end portions 50 and 52 and side portions 32 and 34, may function to absorb this falling impact in a manner that protects and minimizes injury to the falling person.

[0019] As seen in Figure 5, the enclosure 58 is further shaped to receive the side portions and the top portion of a further apparatus when stacking respective ones of the apparatuses 20 together. This may allow the apparatuses to be packed together in an efficient and cost-effective manner for storing and transporting purposes.

[0020] Figures 6 and 7 show an impalement prevention apparatus 20.1 according to a second aspect. Like parts have like numbers and functions as the impalement prevention apparatus 20 shown in Figures 1 to 5 with the addition of “.1”. Apparatus 20.1 is substantially the same as apparatus 20 shown in Figures 1 to 5 with the exception that the spacers are in the form of pairs of spaced-apart, partially-spherical, convexly curved protrusions in this example, as seen by protrusions 60 and 62. The protrusions connect to and extend outwards from the outer surfaces of the side portions, as seen by protrusions 60 and 62 connecting to and extending outwards from the outer surface 44.1 of side portion 32.1 of apparatus 20.1.

[0021] Figures 8 and 9 show an impalement prevention apparatus 20.2 according to a third aspect. Like parts have like numbers and functions as the impalement prevention apparatus 20 shown in Figures 1 to 5 with the addition of “.2”. Apparatus 20.2 is substantially the same as apparatus 20 shown in Figures 1 to 5 with the following exceptions. Top portion 30.2 of the apparatus includes a plurality of space-apart elongate ribs, in this example three ribs 64, 66 and 68 as best seen in Figure 9. The ribs may function to strengthen the top portion of the apparatus 20.2 in a manner that minimizes materials and weight. According to one preferred aspect, the apparatus 20.2 is injection

molded. By providing ribs 64, 66 and 68, top portion 30.2 of the apparatus may be made thinner, thereby facilitating the injection molding process.

[0022] The top portion of the apparatus 20.2 includes a central elongate groove 70 on the inner surface 31.2 thereof which is shaped to receive respective ones of the exposed  
5 ends 24 of the reinforcing bars 22. The groove aligns adjacent to and parallel with central rib 66 in this example. The ribs 64, 66, and 68 are made, in this example, by forming the top portion in a waved manner, with the groove 70 being also formed thereby.

[0023] Figures 10 to 15 show an impalement prevention apparatus 20.3 according to a fourth aspect. Like parts have like numbers and functions as the impalement prevention  
10 apparatus 20.2 shown in Figures 6 and 7 with decimal extension “.3” replacing decimal extension “.2”. Apparatus 20.3 is substantially the same as apparatus 20.2 shown in Figures 6 and 7 with the following exceptions.

[0024] Top portion 30.3 of the apparatus includes a pair of spaced-apart longitudinal  
15 ridges 72 and 74, best seen with reference to Figures 10, 12 and 15, positioned adjacent to respective ones of the side portions 32.3 and 34.3 of the apparatus 20.3. The ridges are flat-topped in this example, though this is not strictly required. Top portion 30.3 of apparatus 20.3 includes an elongate trough 76, best seen in Figures 12 and 15, positioned between the ridges 72 and 74. The trough has a central depression 77 extending downwards from the top portion 30.3 of the apparatus. As seen in Figure 10, ridges 72  
20 and 74 and trough 76 connect to and extend between end portions 50.3 and 52.3 of the apparatus 20.3. Referring to Figure 12, the trough extends downwards into enclosure 58.3 and is positioned between the side portions 32.3 and 34.3 of the apparatus.

[0025] As best seen in Figures 12, 13 and 15, the apparatus 20.3 includes a plurality  
25 of longitudinally spaced-apart webs that connect to and extend between the trough and respective ones of the side portions of the apparatus. This is shown in Figure 15 by web 78 extending between side portion 32.3 and trough 76, and web 82 extending between side portion 34.3 and trough 76. The webs thus connect to and extend between the side

portions 32.3 and 34.3 of the apparatus 20.3. The webs 78 and 82 also connect to and extend downwards from the top portion 30.3 of the apparatus to the bottom 80 of the trough 76 in this example. Portions 79 of the apparatus 20.3 peripheral to and adjacent to each of the webs comprise a generally inverted u-shape in this example as best seen in Figure 15. As best seen in Figures 12 and 13, the apparatus 20.3 also includes a plurality of spaced-apart recesses 84 positioned between adjacent webs. The recesses are generally in the shape of triangular prisms in this example.

[0026] Referring now to Figures 10, 11 and 15, the apparatus 20.3 includes a plurality of longitudinally spaced-apart, lateral ribs 86 positioned within the trough 76 and which connect to and extend between the ridges 72 and 74. The ribs are generally u-shaped in shape in this example as best seen in Figure 15. As seen in Figure 14, in this example, ribs 86 are longitudinally spaced-apart and interposed between webs 82. Referring back to Figure 10, the apparatus 20.3 includes a plurality of spaced-apart recesses 88 positioned between respective ones of its ribs. The recesses are generally in the shape of triangular prisms in this example with square outer ends.

[0027] Side portions 32.3 and 34.3, top portion 30.3 and end portions 50.3 and 52.3 of the apparatus 20.3 are formed by sheet members 90 of substantially the same thickness  $t$ , as best seen in Figures 14 and 15. The apparatus 20.3 so shaped, with its ridges and trough, enables the apparatus to be molded in an efficient manner that inhibits warping, while also providing an effectively thicker and stronger top portion 30.3. Webs 78 and 82 and ribs 86 may further enhance the weight-bearing strength of top portion 30.3. Also, the webs and ribs, together with recesses 84 and 88 and sheet members 90 of the same thickness, may promote effective forming of the apparatus and subsequent cooling during the manufacture of the apparatus.

[0028] As seen in Figure 15, apparatus 20.3 in this example is shaped to snugly receive the exposed ends 24 of the reinforcing bars 22 between the side portions 32.3 and 34.3 thereof. In this case, the ends of the reinforcing bars are fitted between the side

portions of the apparatus at a location 92 which is adjacent to where the side portions of the apparatus connect with the top portion 30.3 of the apparatus.

**[0029]** Figures 16 and 17 show an impalement prevention apparatus 20.4 according to a fifth aspect. Like parts have like numbers and functions as the impalement prevention apparatus 20 shown in Figures 1 to 5 with the addition of decimal extension “.4”. Apparatus 20.4 is substantially the same as apparatus 20 shown in Figures 1 to 5 with the following exceptions.

**[0030]** Apparatus 20.4 is primarily made of plastic, in this example polyethylene, though this is not strictly required and other materials may be used. The apparatus in this embodiment further includes a strengthening plate, in this example a metal plate 94. The plate is made of steel in this example. The plate 94 connects to and extends along the top portion 30.4 of the apparatus 20.4. The plate is embedded within the top portion of the apparatus in this example. Plate 94 includes a pair of spaced-apart curved, longitudinally-extending peripheral edge portions 96 and 98 in this example which abut with and are embedded within side portions 96 and 98 of the apparatus 20.4, respectively, adjacent to corners 39.4 of the apparatus.

**[0031]** As seen in Figure 16, ends 24 of the reinforcing bars 22 are snugly received between side portions 32.4 and 34.4 of the apparatus 20.4 at a location 100 adjacent to where the side portions of the apparatus connect with the top portion 30.4 of the apparatus.

**[0032]** Figure 18 shows an impalement prevention apparatus 20.5 according to a sixth aspect. Like parts have like numbers and functions as the impalement prevention apparatus 20.4 shown in Figures 16 and 17 with decimal extension “.5” replacing decimal extension “.4” and being added for numerals not previously having a decimal extension. Apparatus 20.5 is substantially the same as apparatus 20.4 shown in Figures 16 and 17 with the following exceptions.

**[0033]** The apparatus has an interior 102 and further includes a pair of spaced-apart protrusions 104 and 106 positioned within the interior of the apparatus. The protrusions are longitudinally extending in this example, extending between the end portions of apparatus, though this is not strictly required. Protrusion 104 extends outwards from inner surface 40.5 of side portion 32.5 of the apparatus 20.5 and protrusion 106 extends outwards from inner surface 42.5 of side portion 34.5 of the apparatus. The protrusions are positioned adjacent to and spaced-apart from the top portion 30.5 of the apparatus 20.5. The protrusions 104 and 106 are partially-spherical and have convexly curved outer surfaces 107 and 109 in this example. Plate 94.5 abuts inner surface 31.5 of top portion 30.5 of the apparatus 20.5. The plate is retained in place between the top portion of the apparatus and the protrusions 104 and 106. In one example, plate 94.5 is installed by being pushed past protrusions 104 and 106 and towards inner surface 31.5 of top portion 30.5 of the apparatus when the apparatus has recently come out of the mold and is thus still malleable, with the plate thus being pressed or snapped into place. Edge portions 96.5 and 98.5 of the plate abut protrusions 104 and 106, respectively, when the plate is so positioned in place.

**[0034]** The top portion, side portions and end portions of the various embodiments of the apparatus described herein may be referred to as a means for forming an enclosure extendable around the exposed ends of the bars.

20 **[0035]** It will be appreciated that many variations are possible within the scope of the invention described herein. It will be understood by someone skilled in the art that many of the details provided above are by way of example only and are not intended to limit the scope of the invention which is to be determined with reference to at least the following claim

WHAT IS CLAIMED IS:

1. An impalement prevention apparatus for use with a plurality of spaced-part reinforcing bars having exposed ends, the apparatus comprising:

an elongate top portion shaped to extend over the exposed ends of the bars;

an open end spaced-apart from the top portion of the apparatus, the open end of the apparatus being larger than the top portion of the apparatus.

a pair of elongate, spaced-apart side portions connecting to the top portion and extending downwards therefrom, the side portions extending outwards from the top portion at obtuse angles relative to the top portion; and

a pair of spaced-apart end portions connecting to and extending between the side portions, the end portions further connecting to and extending outwards from the top portion at obtuse angles relative to the top portion, an enclosure being formed by the top portion, the side portions and the end portions so connected together, the enclosure being extendable over the exposed ends of the bars.

2. The apparatus as claimed in claim 1, wherein the end portions are isosceles trapezoids in shape and wherein the side portions are isosceles trapezoids in shape.

3. The apparatus as claimed in claim 1, wherein the top portion includes a plurality of space-apart elongate ribs.
4. The apparatus as claimed in claim 1 further including a plurality of stacking spacers connected to and spaced along the side portions thereof, the spacers providing spacing between side portions of the apparatus and side portions of a further said apparatus when the apparatuses are stacked together.
5. The apparatus as claimed in claim 1 further including a plurality of spaced-apart webs connected to and extending between the side portions of the apparatus, the webs being longitudinally spaced-apart and connecting to and extending downwards from the top portion of the apparatus.
6. The apparatus as claimed in claim 1, the apparatus being shaped to snugly receive the exposed ends of the bars between the side portions of the apparatus at a location adjacent to where the side portions of the apparatus connect with the top portion of the apparatus.
7. The apparatus as claimed in claim 1 wherein the top portion has an elongate groove shaped to receive respective ones of the exposed ends of the bars.
8. The apparatus as claimed in claim 1 wherein the apparatus is tapered from the open end towards the top portion thereof.

9. The apparatus as claimed in claim 1 wherein the top portion includes a pair of spaced-apart longitudinal ridges which are adjacent to respective ones of the side portions of the apparatus, wherein the top portion includes an elongate trough positioned between the ridges, the trough extending downwards and being positioned between the side portions of the apparatus and wherein the apparatus further includes a plurality of longitudinally spaced-apart lateral ribs positioned within the trough, the lateral ribs connecting to and extending between the ridges.
10. The apparatus as claimed in claim 1, further including a strengthening plate connected to and extending along the top portion of the apparatus.
11. The apparatus as claimed in claim 10, wherein the strengthening plate is made of metal, wherein the rest of the apparatus is made of plastic, wherein the top portion of the apparatus has an inner surface, and wherein the plate abuts the inner surface of the top portion of the apparatus.
12. The apparatus as claimed in claim 10, wherein the apparatus has an interior and further includes a pair of spaced-apart protrusions positioned within the interior of the apparatus, the protrusions extending outwards from respective ones of the side portions of the apparatus, and wherein the strengthening plate is interposed between and retained in place by the protrusions and the top portion of the apparatus.

13. The apparatus as claimed in claim 12 wherein the protrusions are partially-spherical and have convexly curved outer surfaces.
14. The apparatus as claimed in claim 10 wherein the plate is u-shaped in cross-section.
15. In combination, a plurality of bars and the apparatus as claimed in any one of claims 1 to 14.



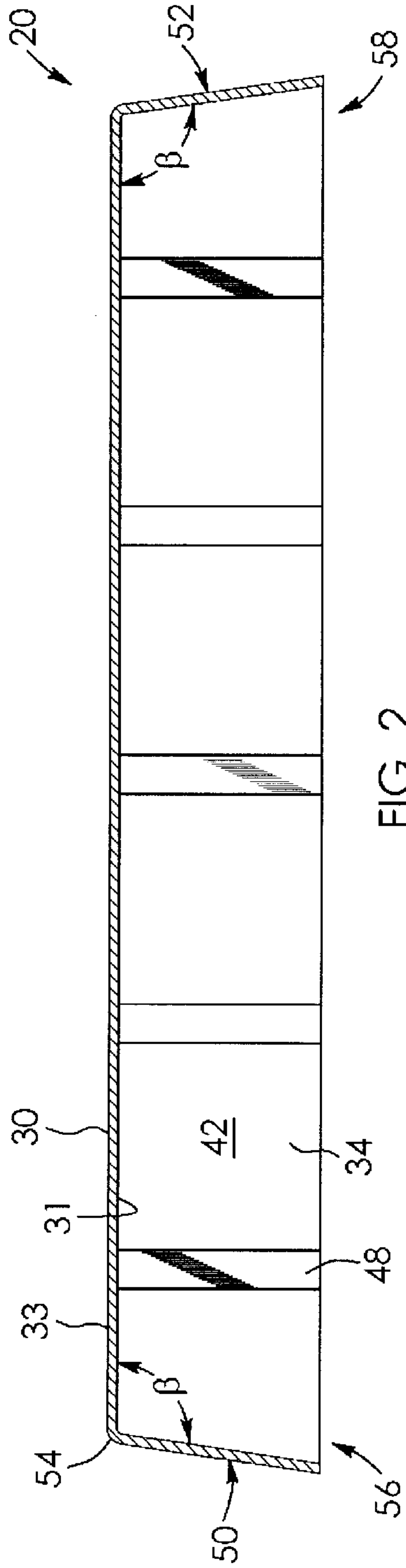

FIG. 2

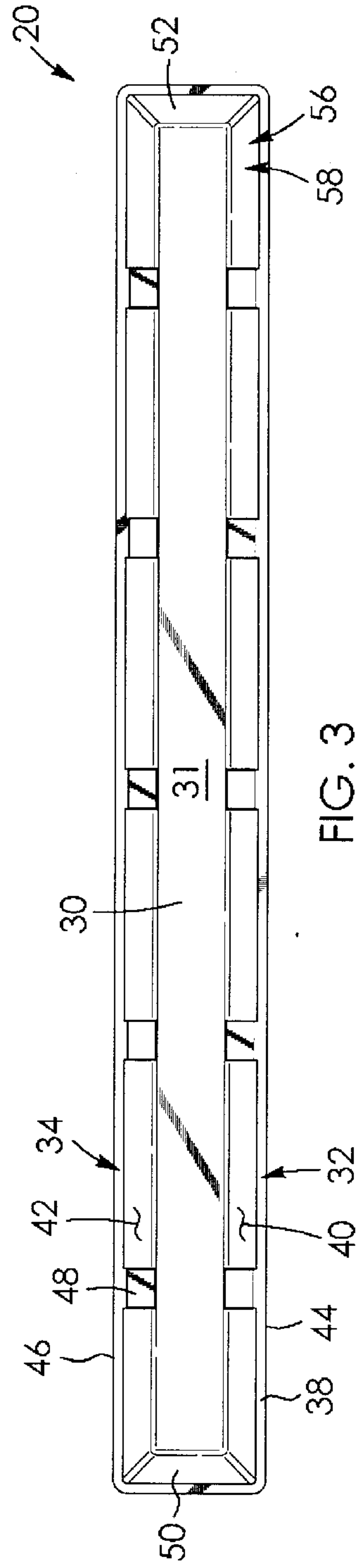

FIG. 3

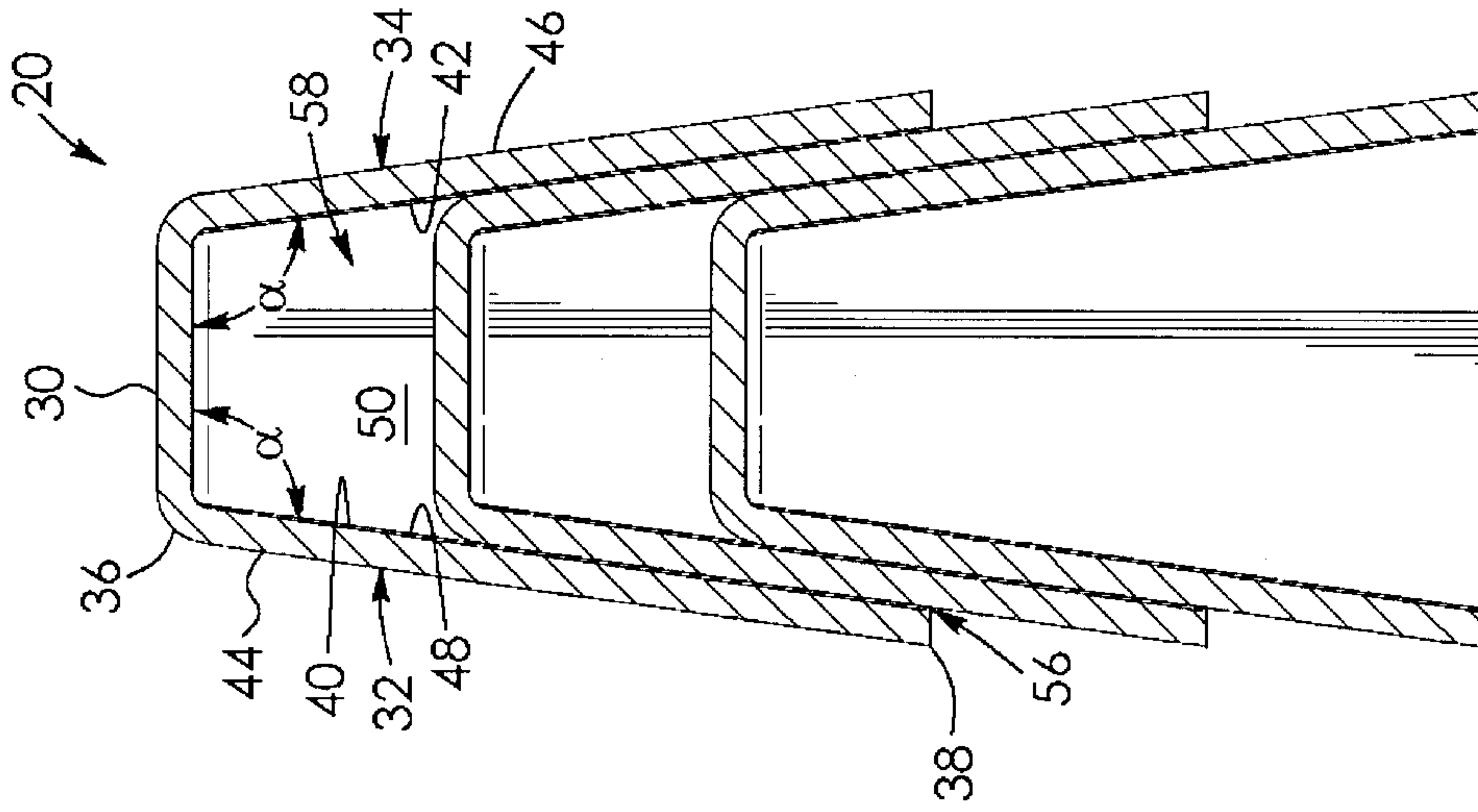

FIG. 5

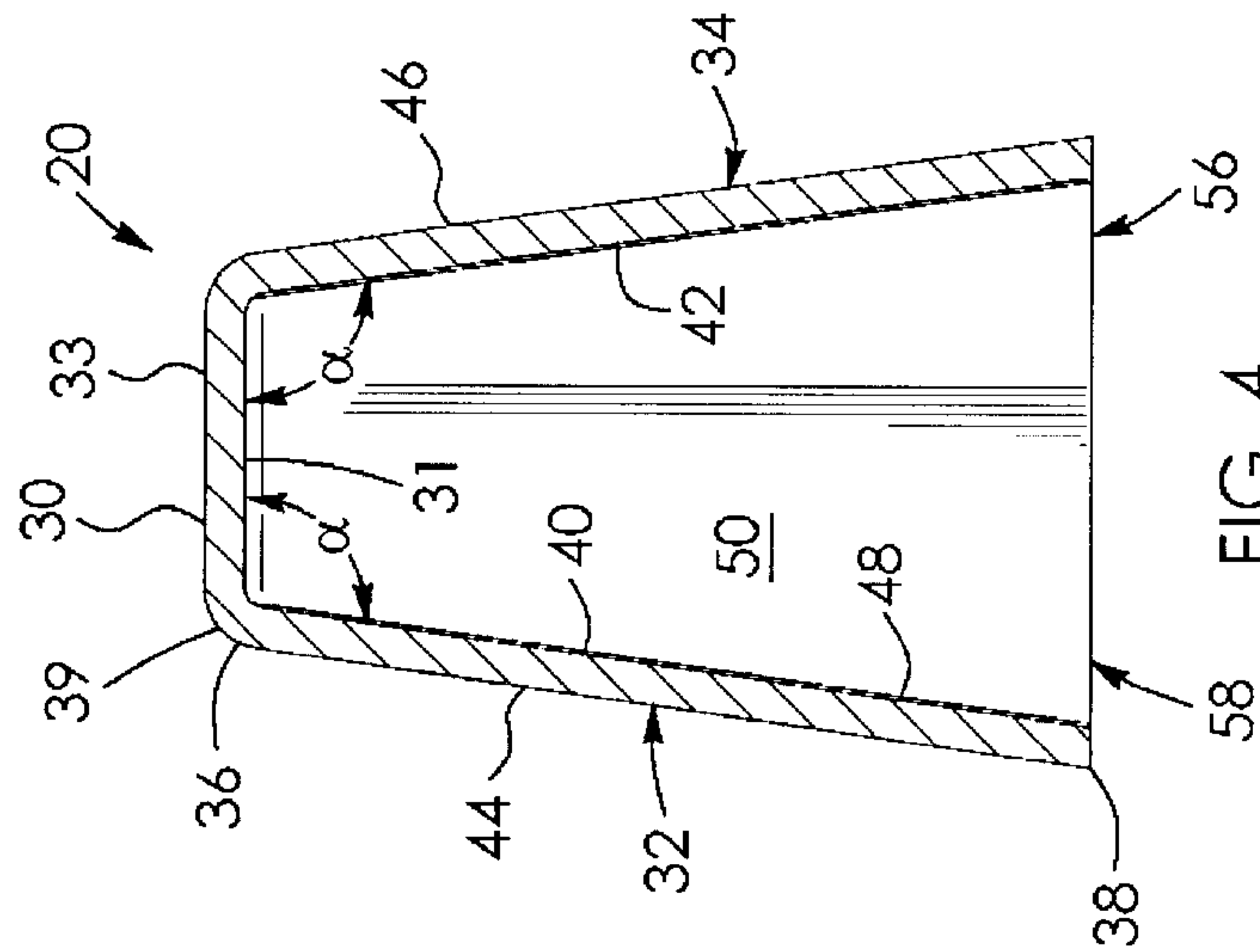

FIG. 4

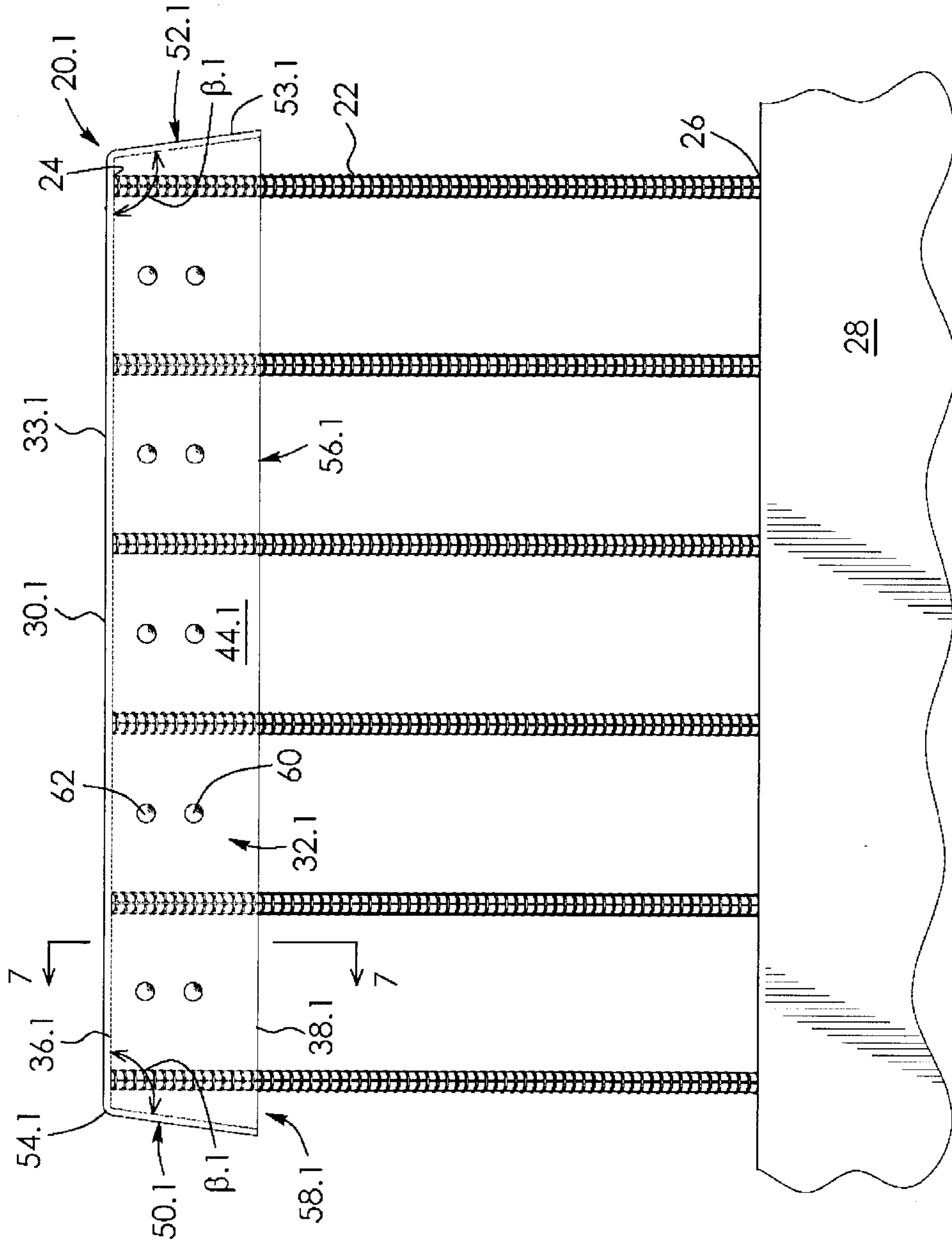

FIG. 6

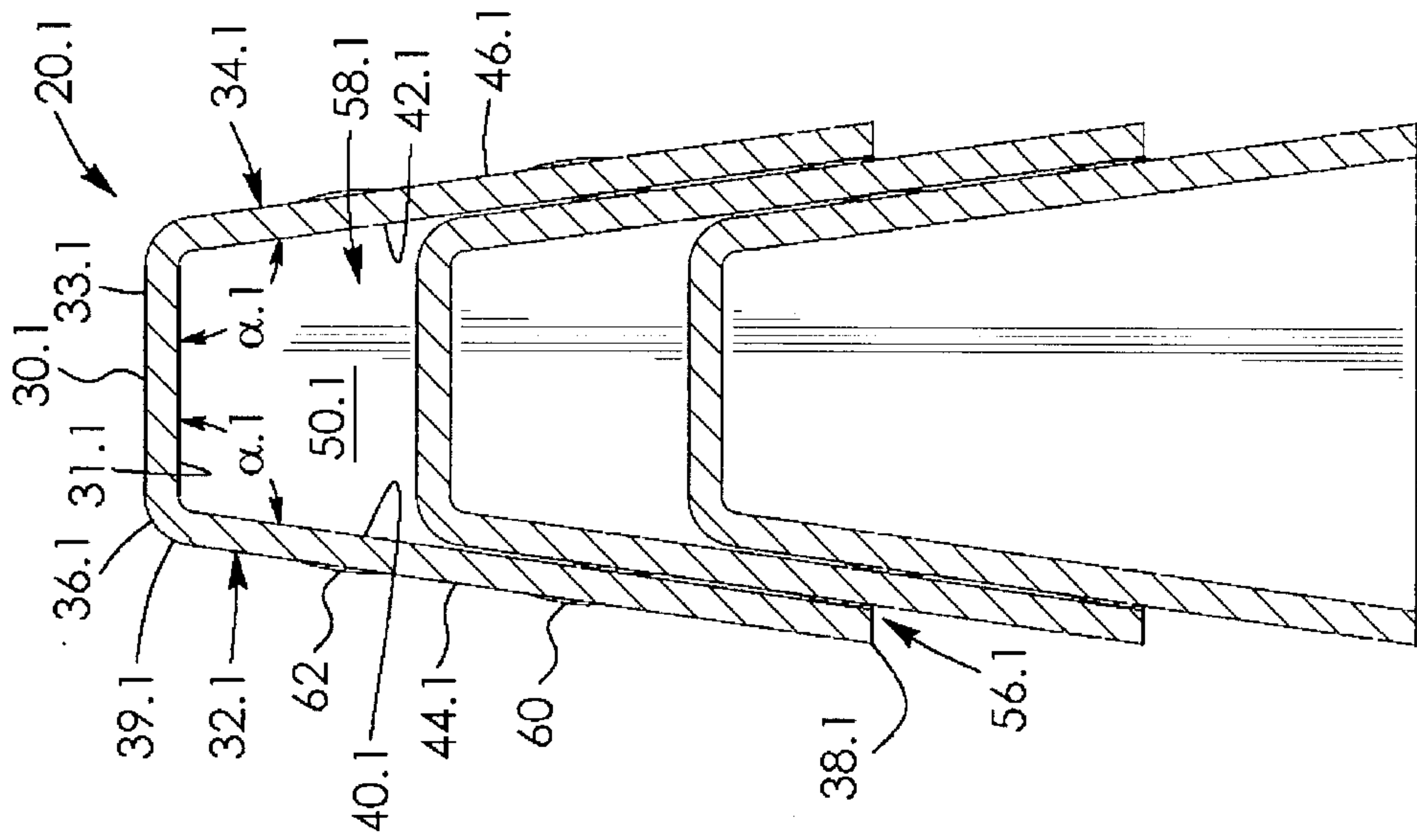

FIG. 7

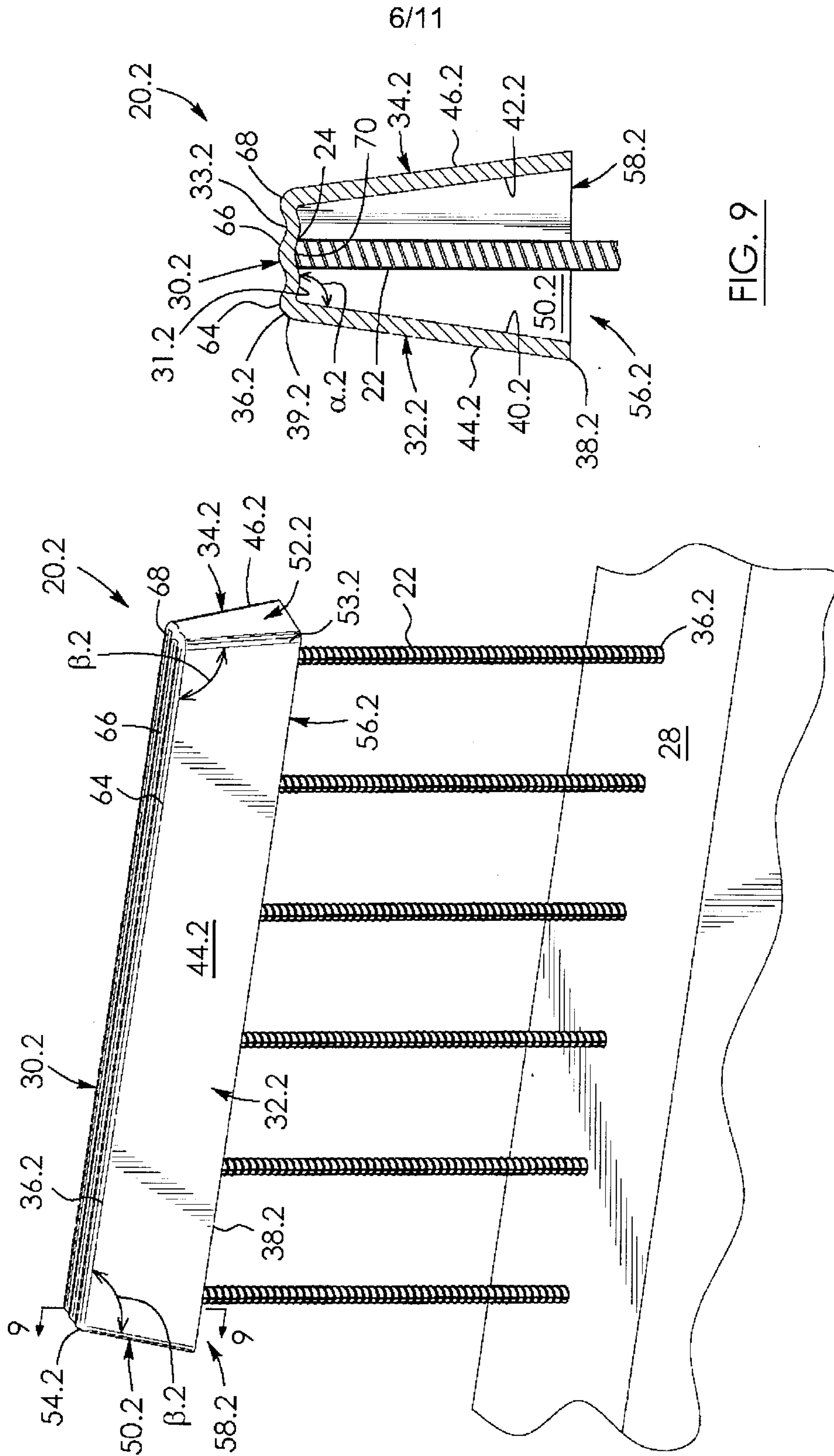
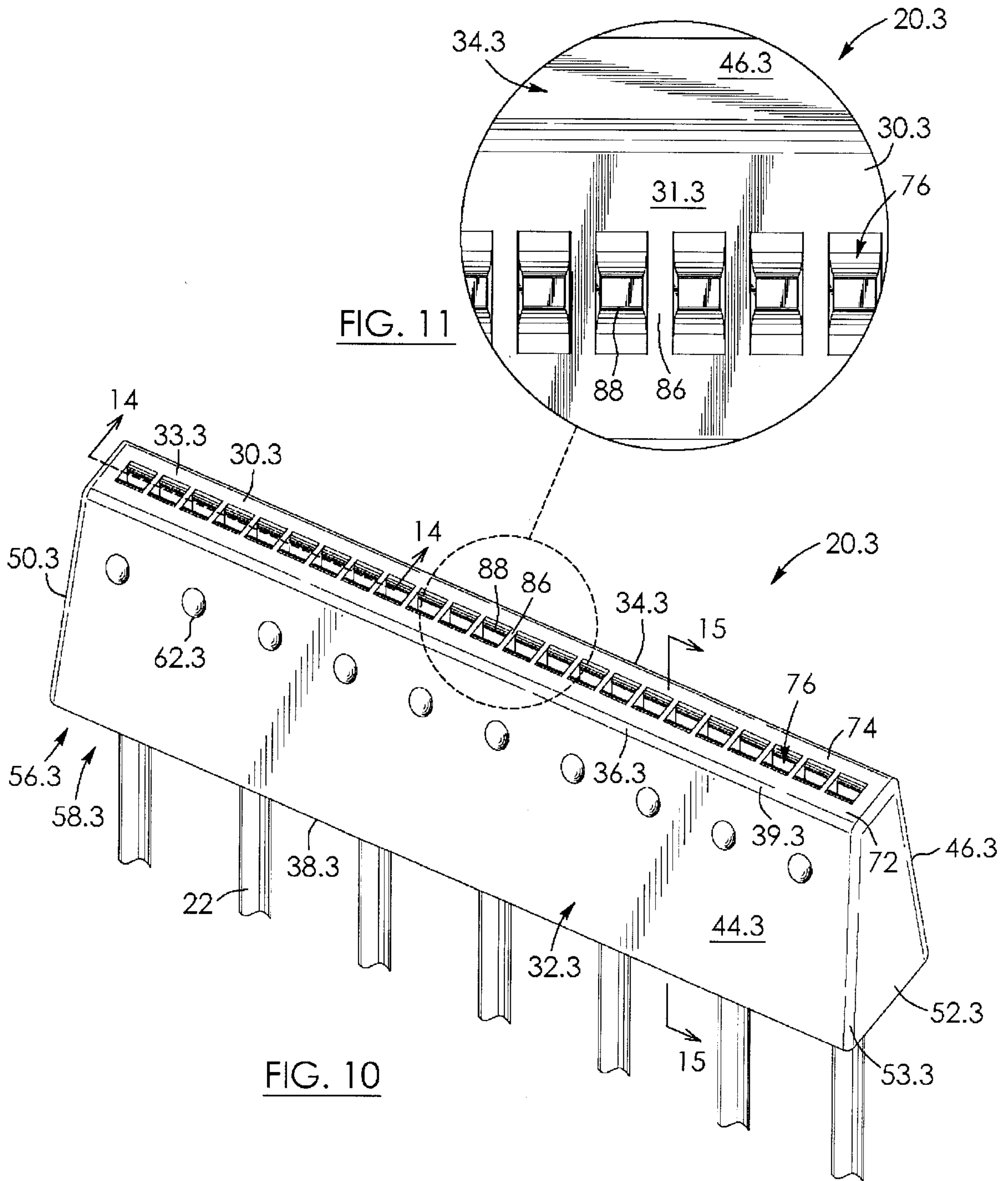

FIG. 9

FIG. 8

7/11



8/11

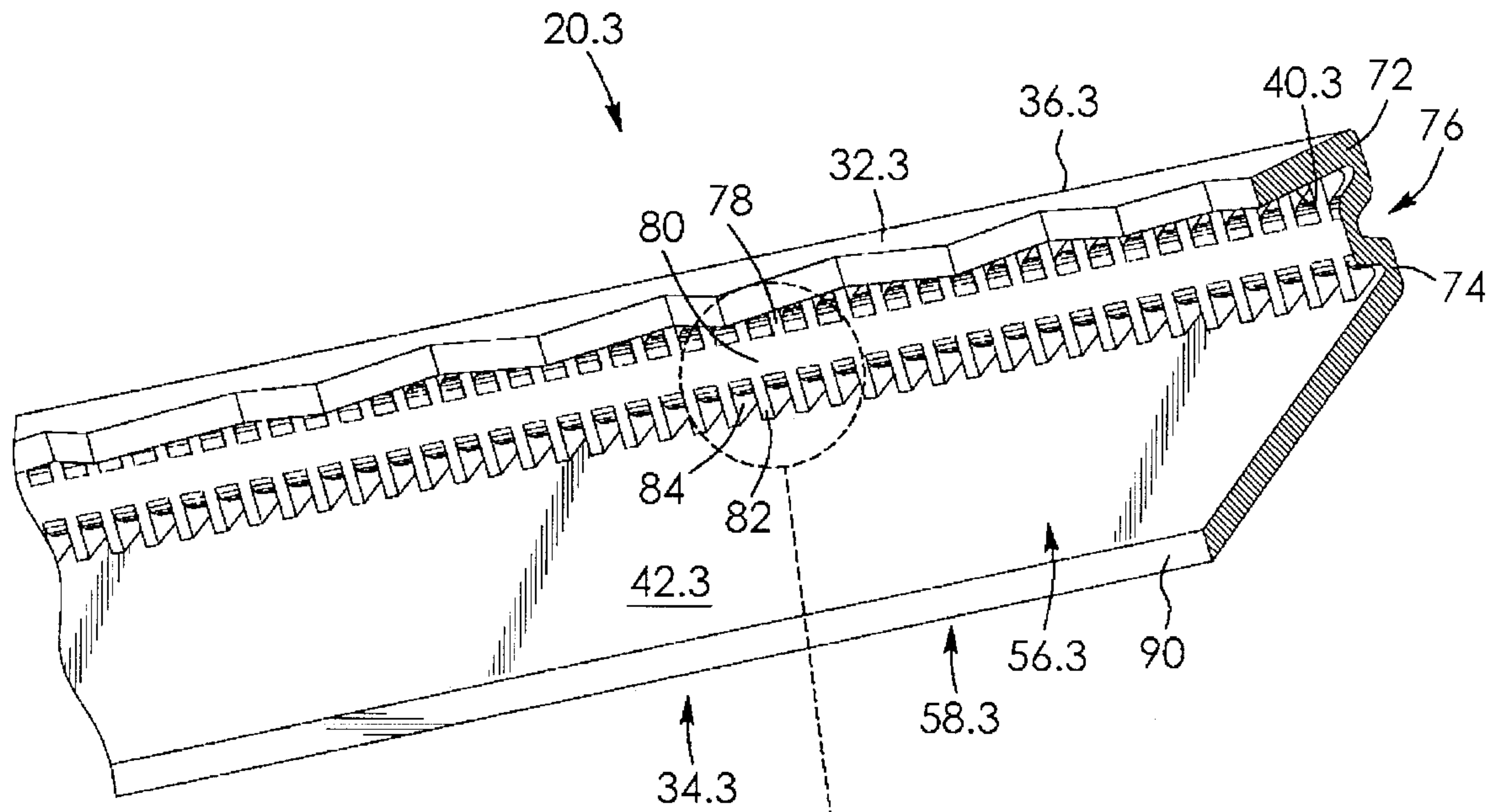

FIG. 12

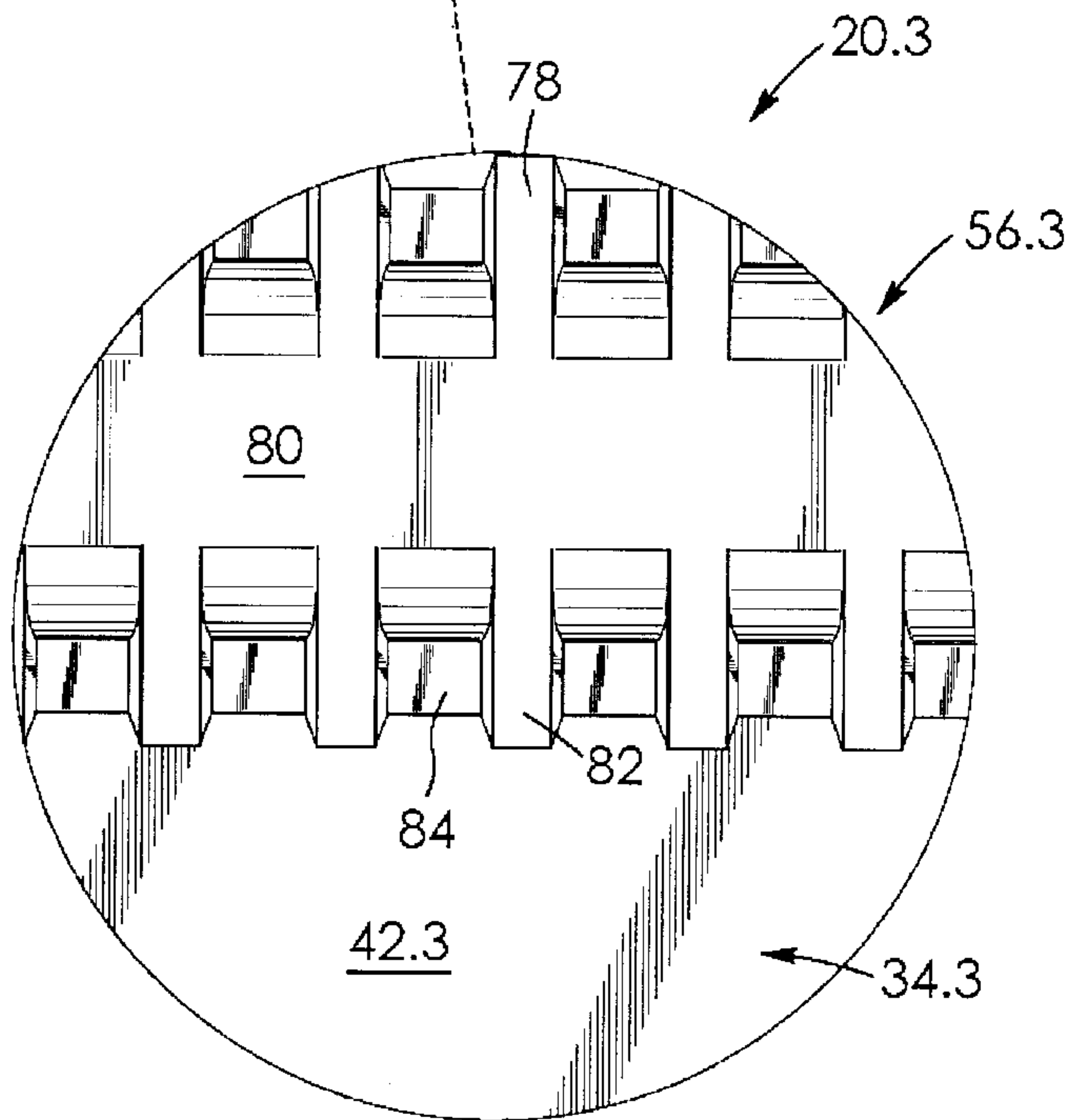

FIG. 13

9/11

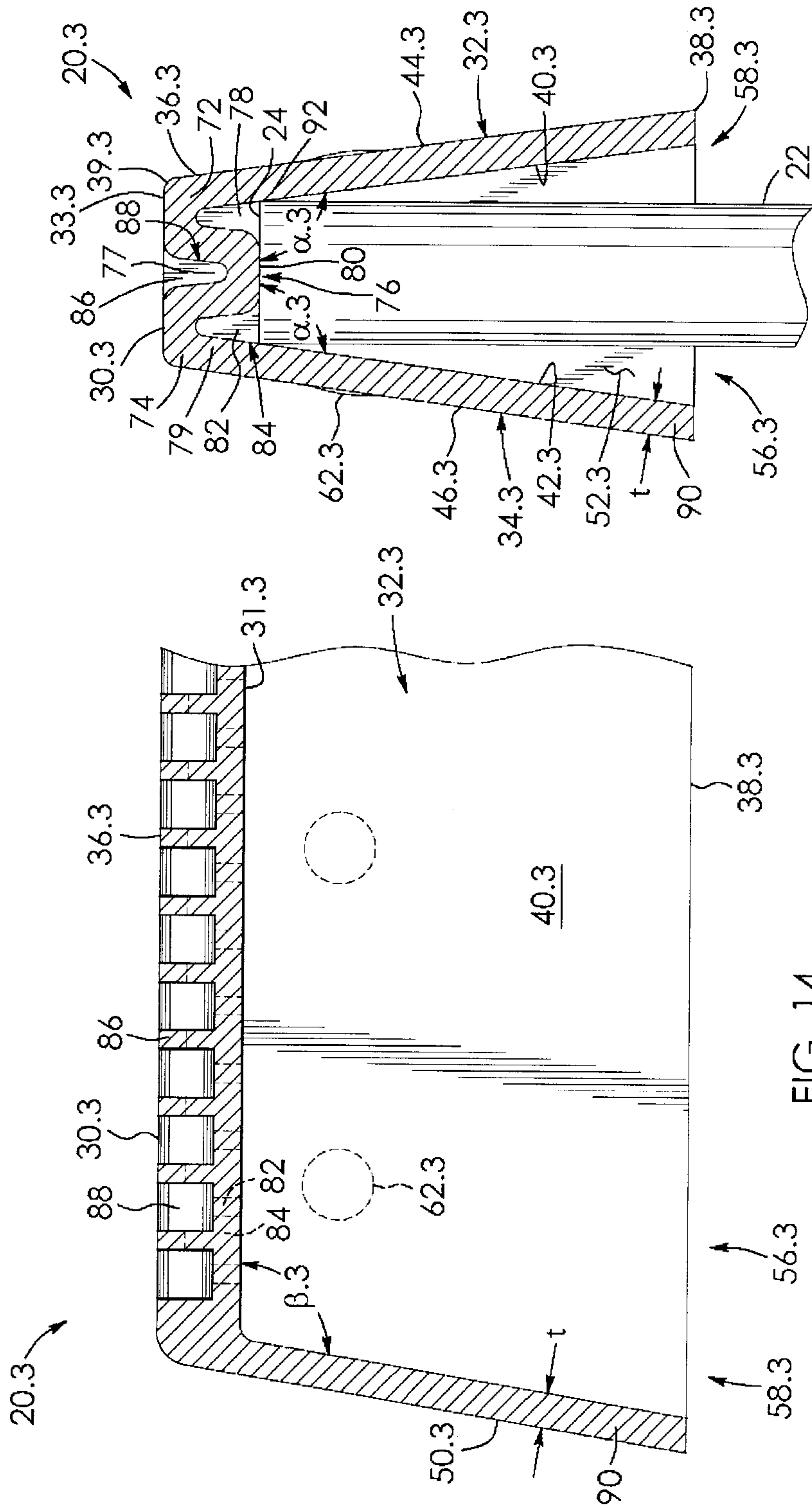

FIG. 14

FIG. 15



11/11

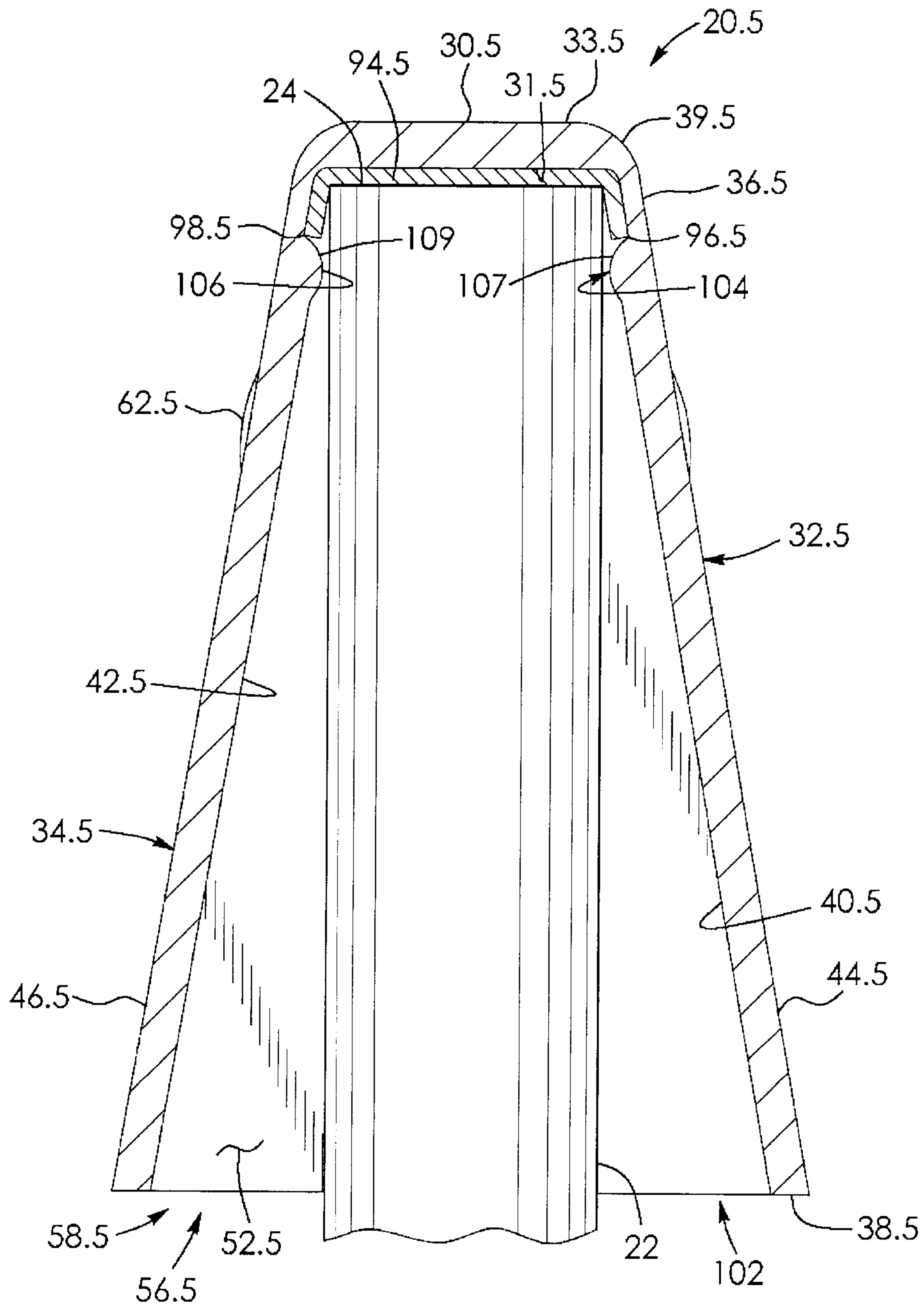

FIG. 18

