

May 30, 1950

G. W. CADJEW

2,509,558

ADVERTISING SIDEWALK BLOCK

Filed March 8, 1948

2 Sheets-Sheet 1

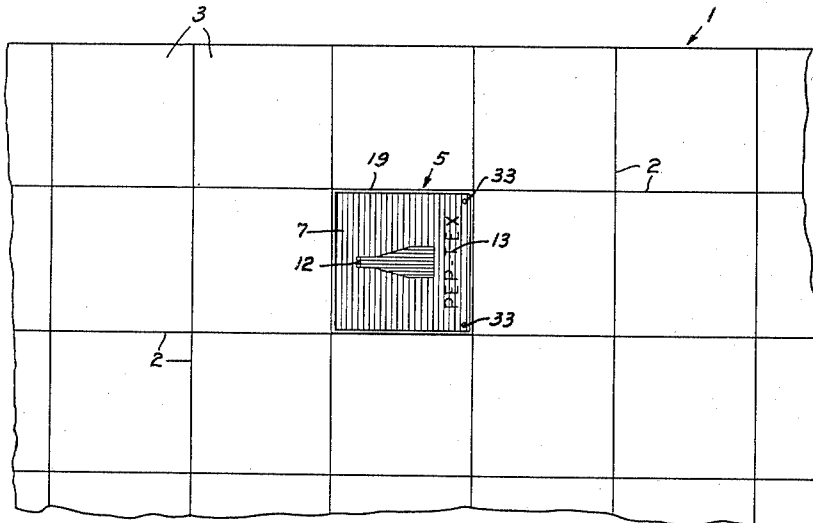

Fig. 1.

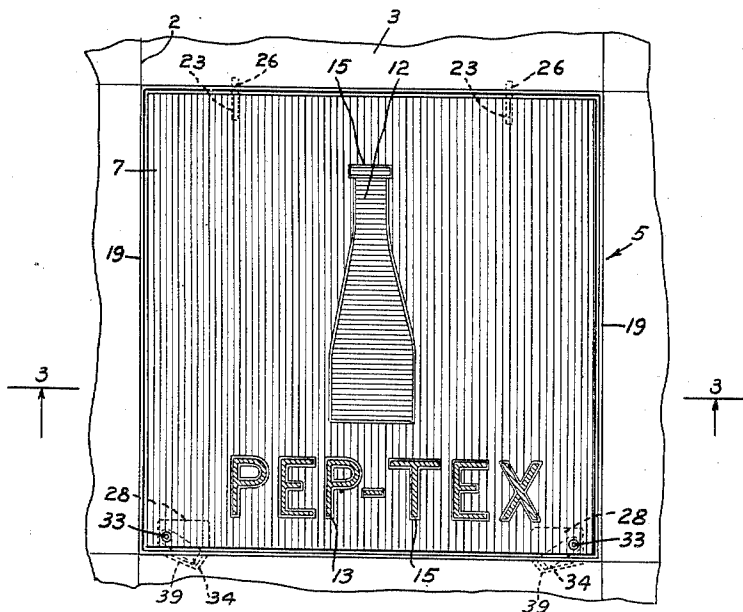

Fig. 2.

INVENTOR.
GARNER W. CADJEW
BY *Alexander Kisboff*
HIS ATTORNEY

May 30, 1950

G. W. CADJEW

2,509,558

ADVERTISING SIDEWALK BLOCK

Filed March 8, 1948

2 Sheets-Sheet 2

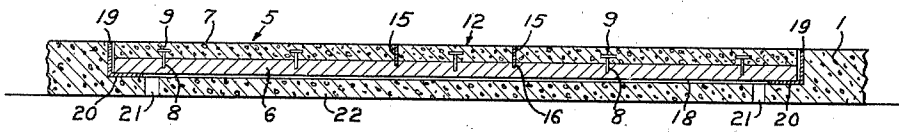

Fig. 3.

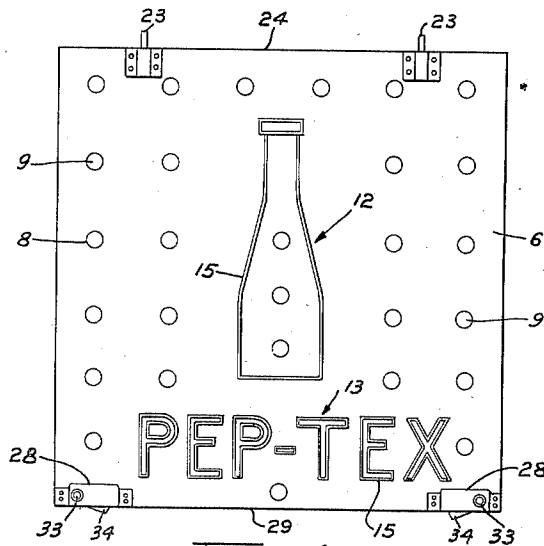

Fig. 4.

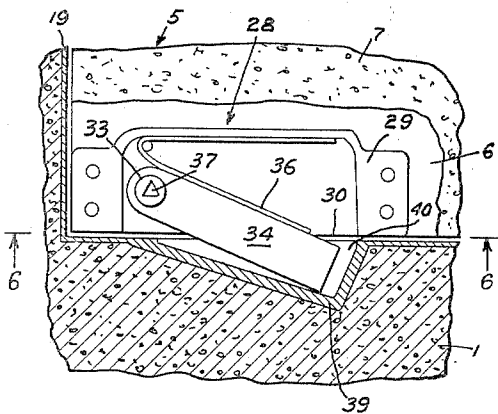

Fig. 5.

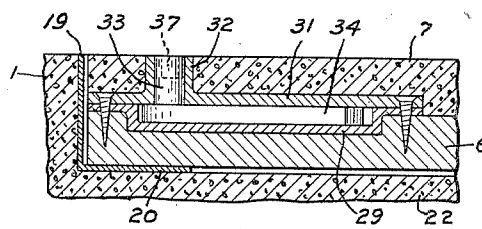

Fig. 6.

INVENTOR.
GARNER W. CADJEW
BY *Alexander Risboff*
HIS ATTORNEY

UNITED STATES PATENT OFFICE

2,509,558

ADVERTISING SIDEWALK BLOCK

Garner W. Cadjew, San Francisco, Calif., assignor
of one-half to Milton C. Cadeaux, San Francisco, Calif.

Application March 8, 1948, Serial No. 13,554

2 Claims. (Cl. 40—125)

1

This invention relates to a sidewalk advertising block.

The object of this invention is to provide a removable concrete block having advertising matter on the face thereof, which block is removably retained in a sidewalk by a locking means.

The other object of this invention is to provide a sidewalk advertising block of a standard size which may be removed from its place and replaced by another block containing the same or different advertising matter.

Another object of this invention is to provide a block of the type described which is light in construction so as to be easily handled, and yet strong and durable enough to withstand the weight of the people walking thereon.

Other objects and advantages will appear as the specification proceeds and the particular features of the invention will be specifically pointed out in the appended claims.

My invention is illustrated in the accompanying drawing in which:

Fig. 1 is a plan view of a portion of a sidewalk, showing an advertising block constructed in accordance with the teachings of this invention.

Fig. 2 is an enlarged view of said advertising block.

Fig. 3 is an enlarged cross-section of said advertising block taken along the line 3—3 of the Fig. 2.

Fig. 4 is a plan view of the base of said block before the concrete is poured thereon.

Fig. 5 is a plan view of the locking means, with the cover removed, and

Fig. 6 is a vertical cross-section of said locking means taken along the lines 6—6 of the Fig. 5, some parts being shown in elevation.

The sidewalk 1 is made of concrete divided by the lines 2 into squares 3, each side of which is equal three feet.

An advertising block 5 takes the place of one of the squares 3 and is of the same size as said squares 3 and has its top even with the latter. The block 5 comprises a base 6 and a layer 7 of concrete on the top thereof. The base 6 is preferably made of three layer water-proof plywood about three-quarters of an inch thick. A plurality of cement coated nails 8, having large heads 9, are driven into said base 6 so that said nail heads are spaced from the top surface of the base about one quarter of an inch. The nails 8 are so placed as to be substantially evenly distributed over said base and are spaced about six inches each from the other. Said nails serve as

2

an anchorage for the concrete layer 7 resting on said base 6.

The block 5 contains an advertising which may be in any form and shape and is shown in the drawings as comprising a bottle 12 and words Pep-⁵Tex indicated at 13. To attract the attention of passers-by, the block 5, the bottle 12 and the words 13 are made of concrete of various bright colors, such as shown in the drawings: the block of 5 of pink concrete, the bottle 12 of blue concrete and the words 13 of green concrete.

The pink concrete of the block proper is separated from the blue concrete of the bottle 12 and from the green concrete of the words 13 by the cooper bands 15 which define the configuration of said bottle and words. The bands 15 are about one inch wide and are retained in their places by grooves 16 made in the base 6, into ¹⁰ which groove the band 15 is forced about one quarter of an inch of its width.

The block 5 is retained in a depression 18 in the sidewalk 1. The depression 18 is defined by a frame 19 made of angle irons securely held ¹⁵ in the concrete of the sidewalk 1. The block 5 is loosely fitted in said frame 19 to facilitate the insertion and extraction of the same into and out of the depression 18. When inserted into the depression 18, the block 5 rests on the horizontal sides 20 of said angle irons, and the bottom of said block 5 is slightly spaced from the bottom of the depression 18, in which space water and dirt accumulate before the same is drained out through a plurality of openings 21 in the concrete base 22, or is manually, or otherwise, ²⁰ cleaned out from time to time.

The block 5 is locked in the depression 18 in the following manner. The base 6 carries two pins 23 attached to the top thereof on the side ²⁵ 24 in spaced relation. The pins protrude beyond the side of said base, and are adapted to be inserted into the holes 26 in the frame 19 which holes extend into the concrete of the sidewalk 1 for some distance. Locks 28 are provided on the top of the base 6 on the side 29 thereof which is opposite to the side 24. Each lock 28 consists of a casing 29 substantially rectangular in shape, one side 30 of which is opened. The casing 29 is covered by a cover plate 31 which is formed with a bearing 32 into which a vertical shaft 33 projects. The shaft 33 is integral with a locking bar 34, located inside of said casing 29. The bar 34 is under constant pressure of a leaf spring 36 which urges said bar outwardly into the position shown in Fig. 5. The bar 34 may be swung

3

inwardly by a key, not shown in the drawing, which is inserted into a key recess 37 in the top of the shaft 33 and rotated in counterclockwise direction, looking at the Fig. 5.

The bars 34 are swung inwardly when the block 5 is inserted into the depression 18 and thereupon the springs 36 force the bars 34 outwardly into keepers 39 welded or otherwise attached to the frame 19. The keeper 39 comprises a small casing opened on one side 40 thereof which is located opposite the open side 30 of the casing 29.

The block 5 is made in the following way: the base 6 of dimensions slightly less than the depression 18, preferably of waterproof plywood is selected and the locking means are attached thereto. The design of the advertising matter and the desired words and figures are drawn thereon. Then the groove 16 is cut along the lines of said design, words and figures, and the copper bands 15 are forced into said grooves 16. Thereupon, the nails 8 are driven into the base 6 as above stated, and colored concrete is poured to fill the space between said bands so as to form the design, words and figures. As soon as the concrete sets in, the balance of the base is covered with concrete in a special form to keep the edge of the concrete even with the edge of the base, and the upper surface of the concrete is smoothed up.

I claim:

1. An advertising sidewalk block adapted to be

4

removably retained in a depression in a sidewalk, comprising a wooden base, a layer of concrete on said base, a plurality of nails partially driven into said base for anchoring said layer of concrete to the base, said layer of concrete containing an advertising indicia, thin, metal bands defining the configuration of said advertising indicia and being partially forced into the base to be retained thereby, and means for locking said block to the sidewalk.

2. In an advertising sidewalk block of the character described and comprising a wooden base and a layer of concrete thereon containing advertising indicia; a plurality of thin metal bands one edge of which is forced into said base to be retained thereby and the other edge is even with the upper surface of said layer of concrete, said metal bands defining the advertising indicia.

GARNER W. CADJEW.

REFERENCES CITED

The following references are of record in the file of this patent:

UNITED STATES PATENTS

Number	Name	Date
640,140	Lloyd -----	Dec. 26, 1889
1,272,177	Almquist et al. -----	July 9, 1918
1,690,842	Sanna -----	Nov. 6, 1928
1,733,161	Lindley -----	Oct. 29, 1929