

(No Model.)

R. E. LINHAM, Dec'd.
H. LINHAM, Executrix.
MOLDING CUTTER.

No. 452,311.

Patented May 12, 1891.

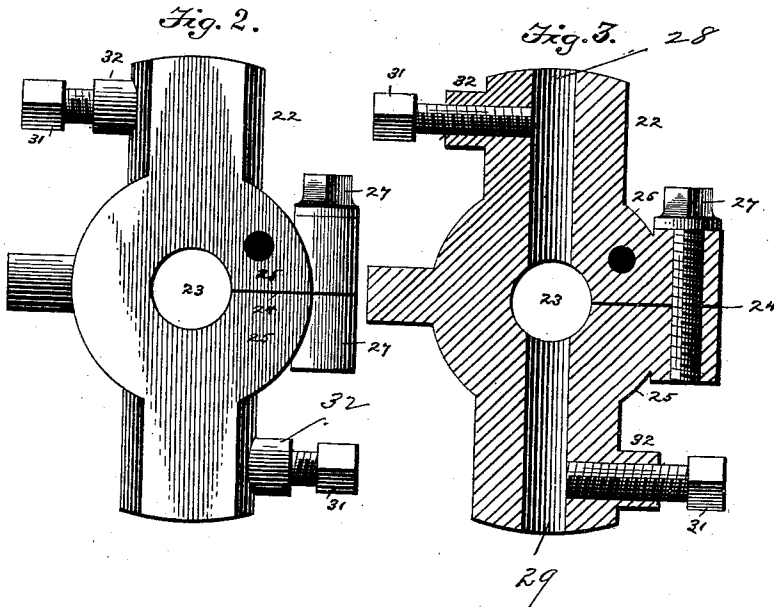
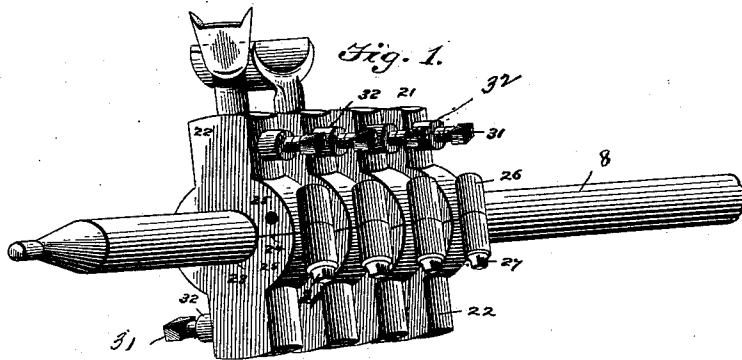

Witnesses:

B. H. Ashbee
John Moore

Robert E. Linham,
Inventor.

By Thomas C. Dunbar,
Attorney.

UNITED STATES PATENT OFFICE.

ROBERT E. LINHAM, OF MANSFIELD, OHIO; HERMIE LINHAM, EXECUTRIX OF SAID ROBERT E. LINHAM, DECEASED, ASSIGNOR, BY MESNE ASSIGNMENTS, TO THE LINHAM DADO MACHINE COMPANY, OF SAME PLACE.

MOLDING-CUTTER.

SPECIFICATION forming part of Letters Patent No. 452,311, dated May 12, 1891.

Application filed February 14, 1890. Renewed April 13, 1891. Serial No. 388,628. (No model.)

To all whom it may concern:

Be it known that I, ROBERT E. LINHAM, a citizen of the United States, residing at Mansfield, in the county of Richland and State of Ohio, have invented certain new and useful Improvements in Molding-Cutters; and I do declare the following to be a full, clear, and exact description of the invention, such as will enable others skilled in the art to which it appertains to make and use the same.

My invention relates to improvements in molding-cutters, and it relates more especially to a "cutter-head."

The leading object of my invention is the provision of a cutter-head which will be thoroughly efficient in operation, which will be strong and durable and inexpensive of production.

To attain the desired objects the invention consists of a cutter-head comprising a member or a series of members mounted on a shaft or arbor, each member comprising a central portion split to form jaws, a screw passing through the jaws to clamp the cutter-head in place, arms extending from the central portion, having each a socket to receive the bits, and a screw in each of the arms for securing the bits.

The invention further consists in the novel construction, arrangement, and adaptation of parts, substantially as herein illustrated, described, and specifically claimed. The members are arranged side by side with relation to each other, and they are all carried by a common arbor or shaft which is positively rotated by suitable appliances. The members of the cutter-head are adjustable radially on the shaft, as well as lengthwise thereon, so that the angle of the members to the arbor can be varied and the distance or space between the members can be varied in order to suit the various conditions or requirements of the cutters to form the different configurations on the work.

To enable others to more readily understand my invention, I will now proceed to a detailed description thereof, in connection with the accompanying drawings, in which—

Figure 1 is a detail view of the shaft or arbor and the cutter-head. Fig. 2 is a perspec-

tive view of one of the members of the cutter-head, and Fig. 3 is a central sectional view taken longitudinally through one of the members of the cutter-head.

Like numerals of reference denote corresponding parts in all the several figures of the drawings.

The cutter-head 21 consists of a series or plurality of members 22 or only of a single member, according to the nature of the molding to be cut and the particular form of the cutter employed to form the molding. It is evident that with a simple molding one cutter of proper configuration may be employed, and hence only a single cutter-head or member may be used; but I prefer to employ two, three, or more members, each constructed to carry one or more cutters in order to provide for cutting a greater variety of moldings with a series of cutters. It will be understood, however, that the cutters are not claimed herein, as they constitute the subject-matter of a series of applications for patents filed of even date herewith, and serially numbered, respectively, 340,467, 340,468, 340,469, 340,470, 340,471, 340,472, and 340,473.

The members of the cutter-head are arranged side by side with relation to each other on the arbor or shaft, and they are substantially the same in construction. Each member consists of a flat casting, which has a transverse central opening 23 to enable the same to be readily slipped or placed on the shaft or arbor, and the member is split or cut at one side of the central opening, as at 24. The flat casting or central portion of the member is of cylindrical form, and thus forms a hub for the arms or spokes, which extend diametrically therefrom. This cut 24 extends radially from the central opening in order to form the jaws 25, which are capable of a slight play laterally of each other, and each jaw has a threaded bearing 25, which are arranged in line with each other to receive a binding-screw 27, whereby the jaws may be compressed upon the arbor and the member be thereby firmly clamped or held on the arbor without separate fastening contrivances.

At diametrically-opposite points each member is provided with the sockets 28 29 for

55

60

65

70

75

80

85

90

95

100

the reception of the shanks of two cutters which are to be carried by said member; but it is obvious that a single cutter-socket may be provided on each member. The socket or sockets extend substantially at right angles to the line of the cut or split portion of the member, and each socket is preferably cylindrical in form, and provided with a smooth interior wall, in order to enable the cutter-shank to be turned axially and moved longitudinally in the socket with freedom and ease, and thus enable the cutter to be adjusted with facility to the desired position in the socket. The shank of the cutter is clamped in the socket by a binding-screw 31, that works in a threaded boss 32, formed laterally in the socket, and by means of this screw the cutter can be firmly clamped in the socket or released therefrom in order to permit of its adjustment in said socket or its removal therefrom. The arbor or shaft is preferably uniform in diameter to enable the members of the cutter-head to be readily adjusted thereon or removed from the same.

By providing each member with the clamping-jaws and the adjusting-screw the members of the cutter-head can be independently clamped in a fixed immovable position on the arbor or shaft, and this clamping means also provides for the easy adjustment of said members when two or more are employed with relation to each other and to the arbor. Thus the distance between two adjacent members can be readily varied, and the members can be turned on said arbor so that the cutters are in line with each other longitudinally of the arbor, or said cutters can be caused to assume various radial positions or angles to the shaft, as is obvious. One, two, three, or more of the members can be used to carry the cutters for making the molding, and each member can carry one or two cutters, all of which depends upon the style or nature of the molding it is desired to produce.

The cutters can be secured in two adjacent members of the head or each alternate member, and each member of the cutter-head can be adjusted and clamped on the arbor independently of the other members. By this means and the employment of suitable cutters I am enabled to provide for cutting a large variety and many different styles of moldings with one machine, which is highly desirable.

The operation and advantages of my invention will be readily understood and appre-

ciated by those skilled in the art from the foregoing description, taken in connection with the drawings.

The cylindrical sockets in the arms of the cutter-heads, in order that the members may be made cheaply and with ease and facility, extend through the entire vertical length of the members. This construction of socket permits the bits to be adjusted vertically to different depths, and by reason of their cylindrical form permits the bits or cutters to be adjusted axially, as circumstances may require.

Changes in the form and proportion of parts and details of construction of the mechanism herein shown and described as embodiments of my invention can be made without departing from the spirit or sacrificing the advantages of my invention, and I would therefore have it understood that I reserve the right to make such modifications as fairly fall within the scope of my invention.

Having thus fully described my invention, what I claim as new is--

1. A cutter-head consisting of a central portion or hub split to form two jaws, a screw passing through the jaws for clamping them on the shaft, arms extending from said central portion or hub, having each a socket to receive the bits, and a screw in each of the arms for securing the bits.

2. A cutter-head consisting of the series of members, each consisting of a split hub having a central opening, the arms extending diametrically from said hub, the cylindrical sockets in said arms, extending the entire length thereof, and the screw passing through the split portion of the hub of the members for securing them on the shaft, substantially as described.

3. A cutter-head consisting of a series of members consisting of a flat casting split to form jaws, threaded bosses on said jaws, a screw passing through the bosses to retain the members on the shaft, arms projecting from said casting, cylindrical sockets in said arms, and screws in the said arms for retaining the bits or cutters in the members, substantially as described.

In testimony whereof I affix my signature in the presence of two witnesses.

ROBERT E. LINIAM.

Witnesses:

ABRAHAM SMALL,
J. C. LASER.