

(No Model.)

4 Sheets—Sheet 1.

A. M. SWEDER.

MACHINE FOR MAKING HORSESHOES.

No. 386,904.

Patented July 31, 1888.

Fig. 1.

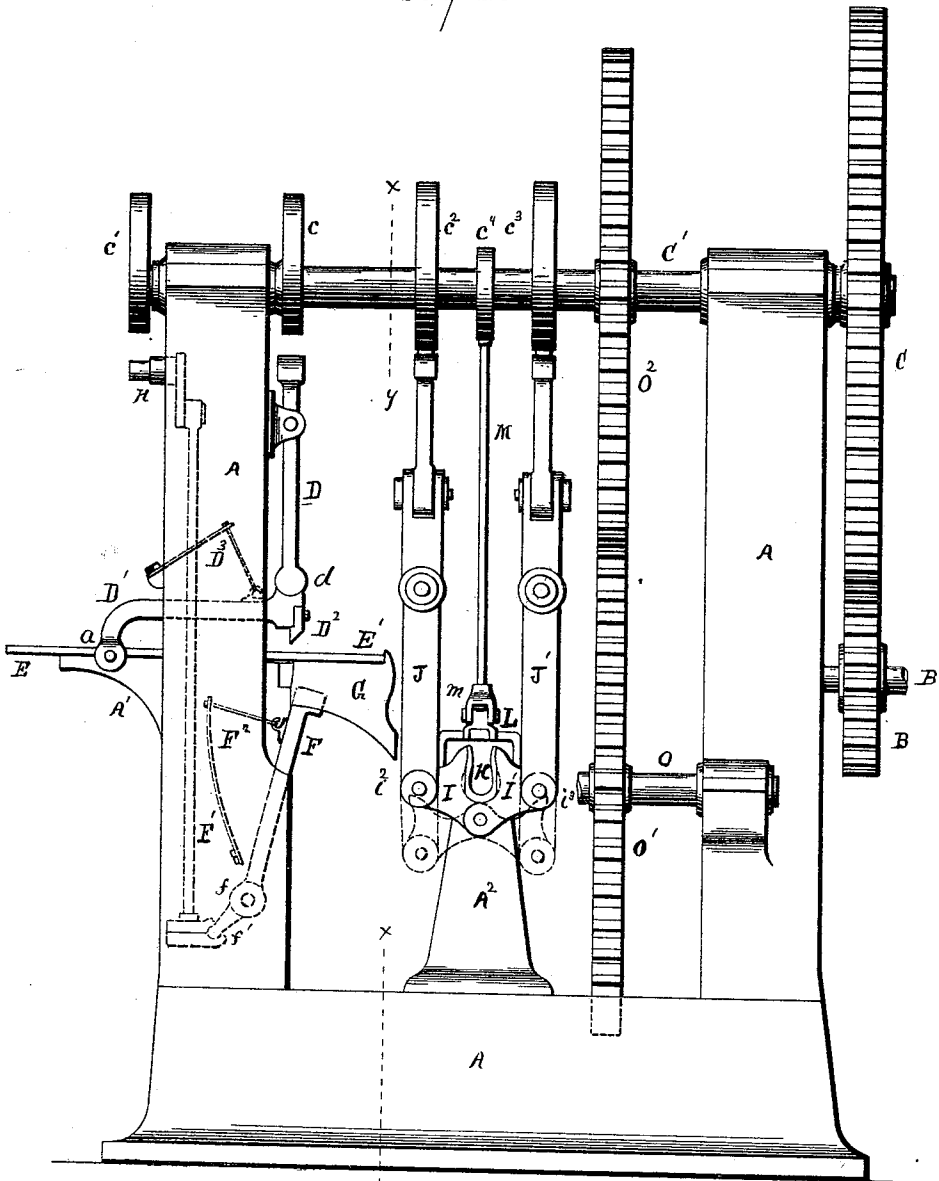

WITNESSES.

*John Lewis.*  
*George H. Briggs.*

INVENTOR,  
*August M. Sweder*  
 By *Newell S. Wright.*

ATTORNEY.

(No Model.)

4 Sheets—Sheet 2.

A. M. SWEDER.

MACHINE FOR MAKING HORSESHOES.

No. 386,904.

Patented July 31, 1888.

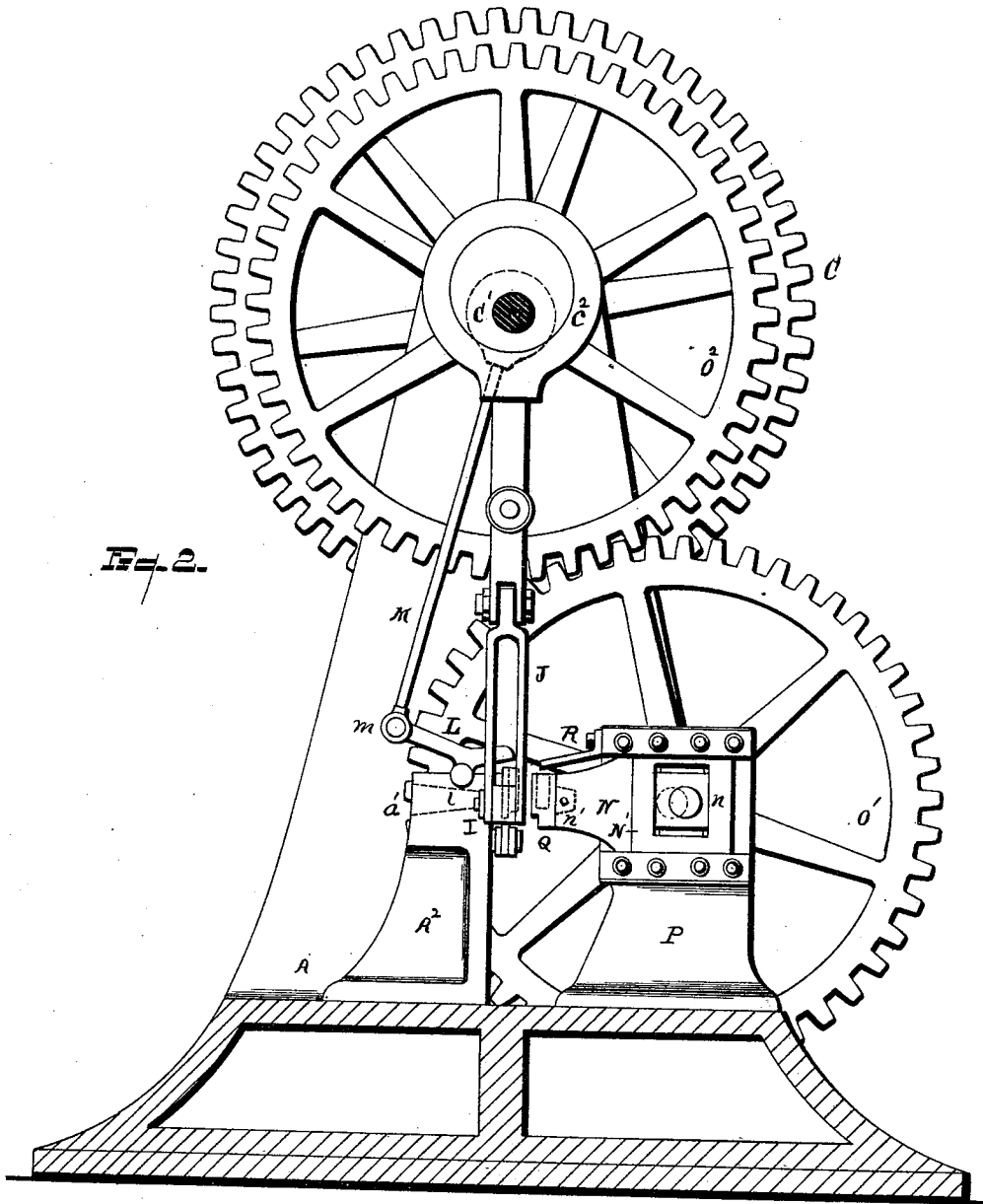

WITNESSES

*John Lewis.*  
*George H. Briggs.*

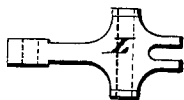

Fig. 12.

INVENTOR.

*August M. Sweder.*  
*By Newell S. Wright.*

ATTORNEY

A. M. SWEDER.

MACHINE FOR MAKING HORSESHOES.

No. 386,904.

Patented July 31, 1888.

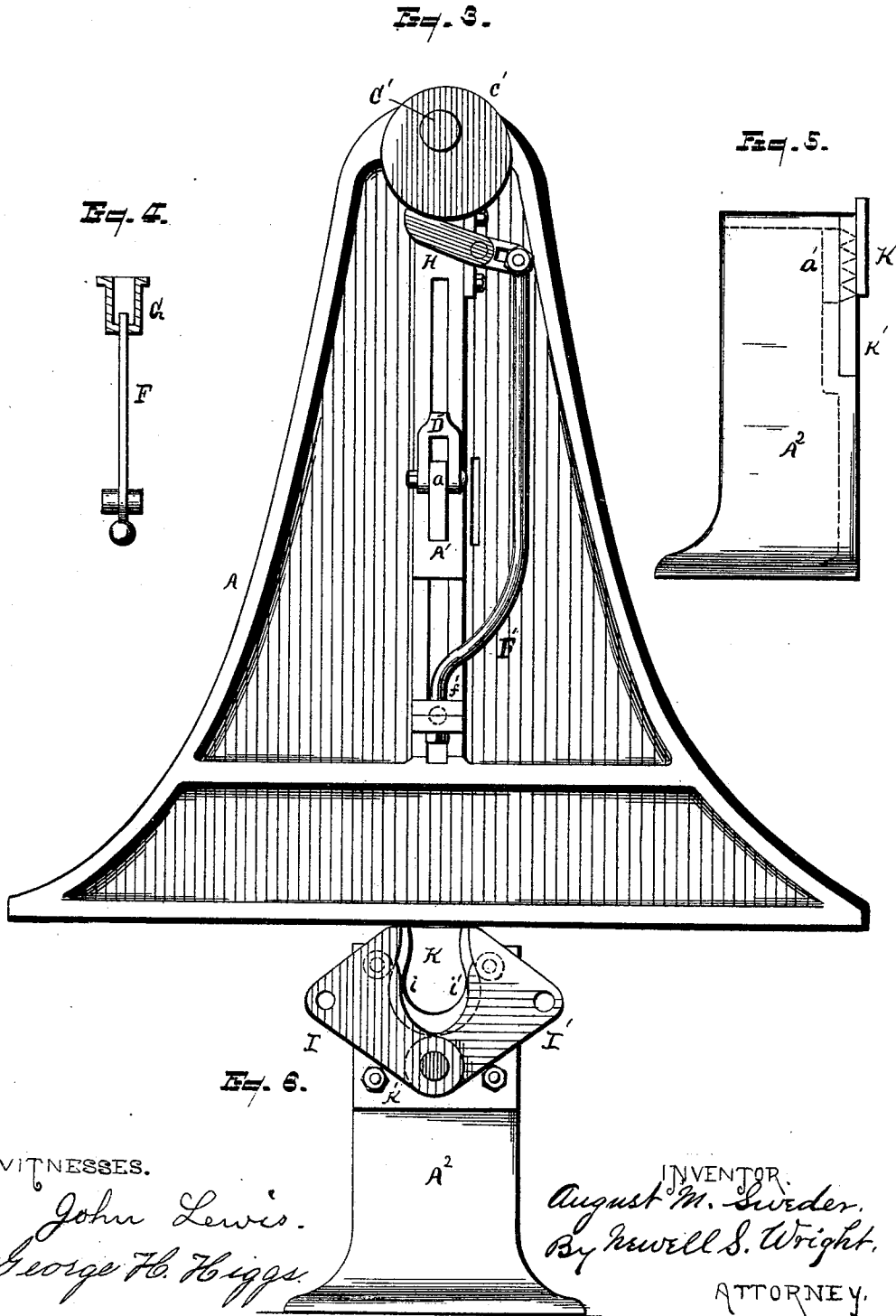

WITNESSES.

*John Lewis.*  
*George H. Biggs*

INVENTOR.

*August M. Sweder.*  
*By Maxwell S. Wright.*

ATTORNEY.

A. M. SWEDER.

MACHINE FOR MAKING HORSESHOES.

No. 386,904.

Patented July 31, 1888.

Fig. 7.

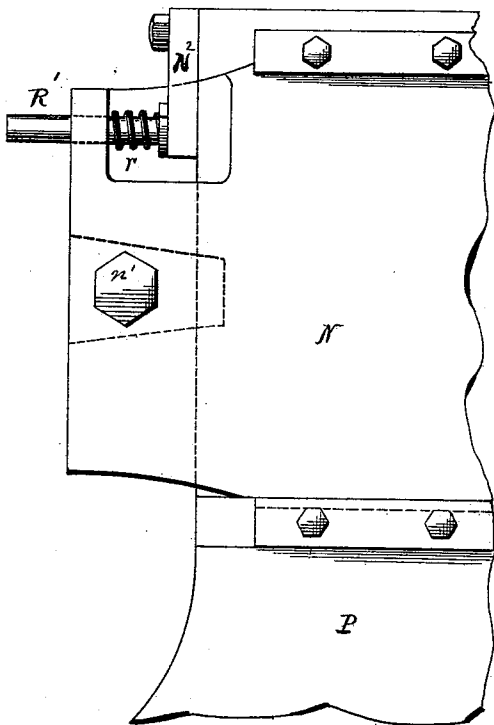

Fig. 8.

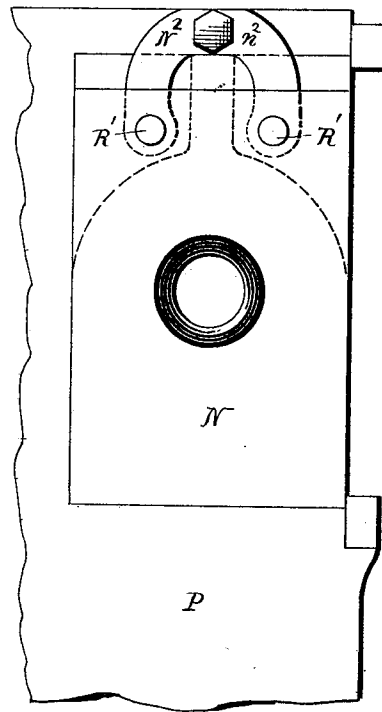

Fig. 9.

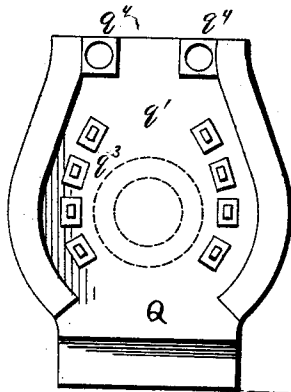
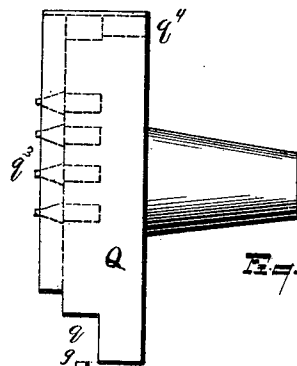
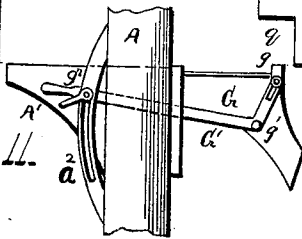

Fig. 10.



WITNESSES.

*John Lewis*  
*George H. Briggs*



INVENTOR.

*August M. Sweder.*  
*By Newell S. Wright.*  
 ATTORNEY.

# UNITED STATES PATENT OFFICE.

AUGUST M. SWEDER, OF MARQUETTE, MICHIGAN, ASSIGNOR OF ONE-HALF  
TO ARTHUR UDDENBERG, OF SAME PLACE.

## MACHINE FOR MAKING HORSESHOES.

SPECIFICATION forming part of Letters Patent No. 386,904, dated July 31, 1888.

Application filed December 31, 1887. Serial No. 259,475. (No model.)

*To all whom it may concern:*

Be it known that I, AUGUST M. SWEDER, a citizen of the United States, residing at Marquette, county of Marquette, State of Michigan, have invented a certain new and useful Improvement in Machines for Manufacturing Horseshoes; and I declare the following to be a full, clear, and exact description of the invention, such as will enable others skilled in the art to which it appertains to make and use the same, reference being had to the accompanying drawings, which form a part of this specification.

My invention pertains to a novel machine for the manufacture of horseshoes; and it consists of the construction, arrangement, and combinations of devices and appliances hereinafter specified, and more particularly pointed out in the claims.

The purpose of the machine embodying my invention is to provide an expeditious device whereby the manufacture of horseshoes may be easily and economically accomplished and their production not only increased in quantity, but also in their uniform quality, so as to be of superior efficiency. This purpose I secure, essentially, first, by providing the machine with devices for cutting from a bar of iron a bar of sufficient length as may be desired for forming the body of the shoe with its heel-calks; second, by providing the machine with presses of suitable form to shape the body of the shoe about an intermediate die or pattern-block; third, by providing mechanism to carry the clipped bar from the knife to said presses; fourth, by providing mechanism to operate said presses to secure the bending of the bar into the form of the shoe; fifth, by providing an auxiliary press to turn the heel-calks; sixth, by providing the machine with an additional press and stamp to perforate the shoe for the reception of the nails, and to prevent the lateral spread of the metal in shaping the body of the shoe; seventh, by providing means for releasing the shoe from the machine when the process of its manufacture is completed; and, eighth, my invention embraces all other general and specific construction and operation of parts illustrated in the accompanying drawings, which

form a part of this specification, and as herein set forth.

In the drawings, Figure 1 is a side elevation of a device embodying my invention. Fig. 2 is a vertical cross-section along the line  $xy$  of Fig. 1. Fig. 3 is a front elevation showing portions of the invention. Fig. 4 is a separate view of the arm F, showing the bridge G in section. Fig. 5 is a separate view of the die in its pedestal in side elevation. Fig. 6 is a front view of the same with the shaping-presses in position thereon. Fig. 7 is a side elevation of a portion of the reciprocatory press; Fig. 8, a front view of the same. Fig. 9 is a front view of the stamp; Fig. 10, a side view thereof; Fig. 11, a separate view of the bridges A' and G, with adjustable mechanism. Fig. 12 is a separate view of the auxiliary press L.

I carry out my invention as follows:

In the drawings, A represents any supporting bed and frame.

B is the driving-gear, mounted upon the driving-shaft B' and meshing with the gear C, mounted upon the driving-arbor C', provided with a series of eccentrics, as hereinafter explained, and also with a gear for driving one of the presses, as further explained in its order. The eccentric  $e$ , located upon said arbor, is arranged to operate upon a reciprocatory bar, D, to depress said bar, the bar having a pivotal engagement,  $d$ , with a cutter-arm, D', which may be pivotally engaged at its opposite end upon a bridge, A', as shown at  $a$ . The cutter-arm is provided with a cutter-blade, D<sup>2</sup>, and any suitable retracting-spring, D<sup>3</sup>. Said arm is made open or bifurcated at its outer end to permit the passage of the metal bar E, supported upon the bridge A'. It is evident, thus, that when the reciprocatory bar D is depressed by the eccentric  $e$  the metal bar will be severed by the cutter-blade upon the arm D', which arm will then be retracted into its normal position.

The severed end E', of suitable length to constitute the body of the shoe with its heel-calks, is carried to the shaping-presses by means of a vibratory arm, F, having its upper end movable in a bridge, G, the construction and arrangement being such that as the head of the

vibratory arm is thrown in the direction of said presses the severed end of the metal bar will be carried thereto.

The vibratory arm may be pivotally engaged, 5 as at  $f$ , upon the supporting-frame, its lower end projected beyond said pivotal engagement, as shown in Fig. 1, to constitute a lever for the vibration of the arm. This lever end of said arm has a jointed engagement, as at  $f'$ , 10 with a connecting-rod,  $F'$ , united at its upper end with the arm  $H$ , operated by the eccentric  $c'$ . As thus constructed, it will be seen that when the eccentric  $c'$  operates the arm  $H$  and its connecting-rod  $F'$  the vibratory arm will 15 be thrown to carry the iron to the presses. Said arm may then be retracted by any suitable spring,  $F^2$ .

$I I'$  are the shaping-presses, having their 20 faces curved into suitable form to shape the bar  $E'$  to constitute the body of the shoe, and flanged, as shown at  $i i'$ , to receive and retain said bar. Said presses are pivotally engaged at one end upon a supporting-pedestal,  $A^2$ , and have a similar engagement at their oppo- 25 site ends, as shown at  $i^2 i'^2$ , with suitable connecting-rods, respectively,  $J J'$ , which rods are operated by eccentrics  $c^2 c^2$ , respectively, on the arbor  $C'$ . Thus the presses may be opened and closed, as shown in the two said 30 positions in Fig. 1 in full and in dotted lines, their position being actuated by the eccentrics  $c^2 c^2$ .

Secured upon the pedestal  $A^2$  is a center die or pattern-head,  $K$ , its periphery being of 35 the desired form of the shoe. This die or head may be made removable and engaged upon the pedestal in any desired manner to form a center bearing, about which the metal is shaped into the proper outline of the shoe 40 as the presses are operated.

To form the heel-calks, I provide an auxiliary press,  $L$ , pivotally engaged upon the said pedestal  $A^2$ , as shown at  $l$ . This press is engaged pivotally intermediate of its extremities, as shown 45 in Fig. 2, so as to have a suitable motion. At one end said press is engaged also with an eccentric,  $c^4$ , upon the arbor  $C'$  by a connecting-rod,  $M$ , having a jointed union with the press, as shown at  $m$ . The opposite end of the press 50 is preferably forked, as shown in Fig. 12, and its forked extremities arranged to bear upon the extremities of the shoe and bend the metal to form the calks at the heel.

$N$  represents a reciprocatory press eccentrically engaged at one end upon a shaft,  $O$ , 55 by means of a sliding head,  $N'$ , operating upon a supporting-bed,  $P$ . The eccentric engagement of said head upon said shaft is shown in Fig. 2 at  $n$ . This shaft is driven by a gear,  $O'$ , 60 meshing with a gear,  $O^2$ , upon the arbor  $C'$ .

$Q$  is a stamp engaged upon the end of the press  $N$ , and held in place in any proper manner, as by a set-screw,  $n'$ . The stamp is flanged upon its face to embrace the outer 55 edges of the metal and prevent the yielding of the metal. The stamp may also be recessed,

as at  $q$ , Fig. 10, for the operation of the shaping-presses.

Within the recess  $q'$  of the stamp are located a series of small punches,  $q^2$ , for the purpose 70 of perforating the shoe to receive the nails, and which is accomplished by the reciprocation of the press  $N$ . These punches may be removable. The pedestal  $A^2$  may be suitably perforated, as at  $a'$ , to permit the ready dis- 75 charge of the chips punched from the shoe.

To release the shoe any desired device may be used—as, for instance, an arm,  $R$ , may be engaged upon the bed  $P$  to throw off the shoe 80 as the press  $N$  is retracted. The shoe naturally adheres to the stamp  $Q$  as the press is drawn backward. I prefer, however, a construction shown in Figs. 7 and 8, where the press  $N$  is shown provided with the bars  $R'$  engaged in the 85 orifices  $q'$  of the stamp and provided with retracting-springs  $r'$ . The inner ends of said bars are made to abut against a stationary yoke,  $N^2$ , engaged upon the pedestal or bed  $P$ , as shown at  $n^2$ . It will be seen that as soon as the press moves rearward the heads of the bolts 90 will crowd the shoe off.

It will be seen that the bed  $P$  and pedestal  $A^2$  are but parts of the general bed or frame  $A$ .

By making the pattern-head  $K$  and stamp 95  $Q$  removable others of desired size may readily take their places for the manufacture of different-sized shoes. For this purpose it is also desirable to make the presses  $I I'$  removable. Accordingly, said presses and the head 100  $K$  may be removably engaged upon the pedestal  $A^2$  directly; but I prefer to engage said devices upon a removable face-plate,  $K'$ , engaged upon said pedestal. Moreover, in the manufacture of various sizes of shoes, it will 105 be necessary to control the length of metal to be cut from the bar  $E$ . This may be done as follows: The bridge  $G$ , as shown in Fig. 11, may be provided with an adjustable stop,  $g$ , operated by a suitable lever,  $G'$ , pivotally engaged or fulcrumed upon said bridge, as at  $g'$ , 110 said lever at its outer end movable along an arc,  $a^2$ , upon the frame, said arc provided with an elongated slot, in which the lever may be set at any desired point by a set-screw,  $g^2$ .

By a proper mechanical arrangement and 115 adjustment of parts the different steps in the process of manufacture of the shoes may be made to take place consecutively in desired relation and order with accuracy and precision. The various features are simple in con- 120 struction and operation, not likely to get out of order, and thereby a considerable number of shoes may be turned out per minute and perfect in their construction.

What I claim as my invention is— 125

1. In a machine for the manufacture of horseshoes, the combination, with a supporting-bed and a pattern-head, of reciprocatory shaping-presses pivoted to a support stationary with respect to the pattern-head, and 130 means for actuating the presses to form the body of the shoe, substantially as set forth.

2. In a machine for the manufacture of horseshoes, the combination, with a supporting-bed, of a pattern-head and reciprocatory shaping-presses pivotally secured to the bed, and means for actuating the presses to bend the metal of the shoe about said head, substantially as described.
3. In a machine for the manufacture of horseshoes, the combination, with a supporting-bed, of a removable pattern-head and reciprocatory shaping-presses pivotally secured to the bed, and means for actuating the presses to bend the metal of the shoe about said head, substantially as described.
4. In a machine for the manufacture of horseshoes, the combination, with a supporting-bed, of reciprocatory shaping-presses pivotally secured to the bed and flanged upon their working-faces, and means for actuating the presses, substantially as and for the purpose described.
5. In a machine for the manufacture of horseshoes, the combination, with a supporting-bed, of shaping-presses to form the body of the shoe, said presses pivotally engaged upon said bed and eccentrically operated, substantially as described.
6. In a machine for the manufacture of horseshoes, the combination, with the supporting-bed and frame provided with a driving-arbor, of shaping-presses to form the body of the shoe, said presses being pivotally secured to the supporting-bed and operated by an eccentric upon said arbor, substantially as set forth.
7. In a machine for the manufacture of horseshoes, the combination, with a supporting-bed, of a reciprocatory press, L, to bend the heel-calks, substantially as set forth.
8. In a machine for the manufacture of horseshoes, the combination, with a supporting-bed, of an eccentrically-operated press to bend the heel-calks, substantially as described.
9. In a machine for the manufacture of horseshoes, the combination, with a supporting bed or frame, of a driving-arbor provided with an eccentric and a press to bend the heel-calks, said press operated by said eccentric and having a pivotal engagement upon said bed, substantially as set forth.
10. In a machine for the manufacture of horseshoes, the combination, with a supporting-bed, of a reciprocatory press, N, constructed to move in a right line toward and away from its work, substantially as and for the purpose set forth.
11. In a machine for the manufacture of horseshoes, the combination, with a supporting-bed, of a reciprocatory press, N, constructed to move in a right line toward and away from its work and provided with a stamp, Q, substantially as and for the purpose set forth.
12. In a machine for the manufacture of horseshoes, the combination, with a supporting-bed, of a reciprocatory press, N, constructed to move in a right line toward and away from its work and provided with a stamp, Q, said stamp provided with a series of punches, substantially as and for the purpose set forth.
13. In a machine for the manufacture of horseshoes, the combination, with a supporting-bed, of a press, N, and a rotatable shaft, O, said press operated from said shaft, substantially as described.
14. In a machine for the manufacture of horseshoes, the combination, with a supporting-bed, of a rotatable shaft, O, and a press, N, provided with a sliding head engaged upon said bed, said head eccentrically operated from said shaft, substantially as described.
15. In a machine for the manufacture of horseshoes, the combination, with a supporting-bed, of a reciprocatory press, N, constructed to move in a right line toward and away from its work, and a releasing device, substantially as described.
16. In a machine for the manufacture of horseshoes, the combination, with a supporting-bed, of reciprocatory shaping-presses and a reciprocatory cutter independent of the shaping-press, substantially as described.
17. In a machine for the manufacture of horseshoes, the combination, with a supporting-bed, of reciprocatory shaping-presses to form the body of the shoe and an auxiliary reciprocatory press to bend the heel-calks, substantially as set forth.
18. In a machine for the manufacture of horseshoes, the combination, with a supporting-bed, of reciprocatory shaping-presses to form the body of the shoe, an auxiliary reciprocatory press to bend the heel-calks, and a reciprocatory press, N, to perforate the shoe, substantially as set forth.
19. In a machine for the manufacture of horseshoes, the combination, with the supporting bed or frame, of shaping-presses pivotally secured at one end to a suitable frame and operated by eccentric connections connected with their opposite ends, substantially as set forth.
20. In a machine for the manufacture of horseshoes, the combination, with a supporting bed or frame, of a cutter-arm pivotally engaged at one end therewith, a driving-arbor provided with an eccentric, said arm operated by said eccentric, and a spring to retract said arm, substantially as described.
21. In a machine for the manufacture of horseshoes, the combination, with a supporting bed or frame, of the vibratory arm F, substantially as and for the purpose set forth.
22. In a machine for the manufacture of horseshoes, the combination, with a supporting bed or frame, of the vibratory arm F, pivotally engaged thereupon, and a driving-arbor eccentrically connected with said arm, substantially as described.
23. In a machine for the manufacture of horseshoes, the combination, with a support-

ing bed or frame, of reciprocatory shaping-presses to form the body of the shoe, a cutter, and means for feeding the metal to said presses, substantially as described.

5 24. In a machine for the manufacture of horseshoes, the combination, with a supporting bed or frame, of a driving-arbor, shaping-presses I I', auxiliary press L, press N, and cutter, said presses and cutter driven from  
10 said arbor, substantially as described.

25. In a machine for the manufacture of

horseshoes, the pattern-head and shaping-presses mounted upon a pedestal, A<sup>2</sup>, and removably connected therewith, substantially  
15 as described.

In testimony whereof I sign this specification in the presence of two witnesses.

AUGUST M. SWEDER.

Witnesses:

S. L. JAHNASON,  
O. T. BORGERSON.