

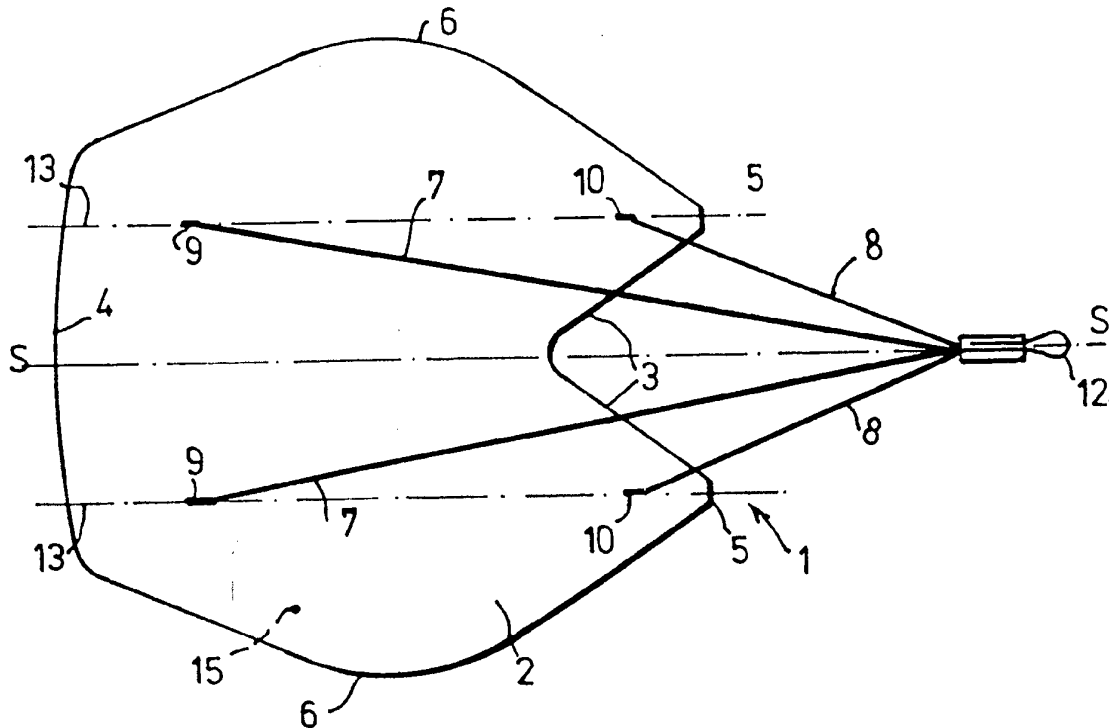

INTERNATIONAL APPLICATION PUBLISHED UNDER THE PATENT COOPERATION TREATY (PCT)

<p>(51) International Patent Classification<sup>5</sup> : <b>B63D 21/40</b></p>	<p><b>A2</b></p>	<p>(11) International Publication Number: <b>WO 94/12386</b> (43) International Publication Date: 9 June 1994 (09.06.94)</p>
<p>(21) International Application Number: PCT/NL93/00257 (22) International Filing Date: 1 December 1993 (01.12.93) (30) Priority Data: 92.02083 1 December 1992 (01.12.92) NL  (71) Applicant (for all designated States except US): VRIJHOF ANKERS BEHEER B.V. [NL/NL]; Meerkoetstraat 83a, NL-2990 AC Krimpen s/s IJssel (NL). (72) Inventor; and (75) Inventor/Applicant (for US only): VAN DEN HAAK, Rob [NL/NL]; Meerkoetstraat 83a, NL-2990 AC Krimpen s/s IJssel (NL). (74) Agent: FERGUSON, A.; Octrooibureau Vriesendorp &amp; Gaade, P.O. Box 266, NL-2501 AW The Hague (NL).</p>		<p>(81) Designated States: AT, AU, BB, BG, BR, BY, CA, CH, CZ, DE, DK, ES, FI, GB, HU, JP, KP, KR, KZ, LK, LU, LV, MG, MN, MW, NL, NO, NZ, PL, PT, RO, RU, SD, SE, SK, UA, US, UZ, VN, European patent (AT, BE, CH, DE, DK, ES, FR, GB, GR, IE, IT, LU, MC, NL, PT, SE), OAPI patent (BF, BJ, CF, CG, CI, CM, GA, GN, ML, MR, NE, SN, TD, TG).  <b>Published</b> <i>In English translation (filed in Dutch). Without international search report and to be republished upon receipt of that report.</i></p>

(54) Title: ANCHOR FLUKE



(57) Abstract

Anchor fluke comprising a bottom side and an upper side and a longitudinal plane of symmetry, the upper side being defined by two convexly bent faces, formed by faces ascending in a convex manner from the sharp front edge in a symmetrical fashion relative to the longitudinal plane of symmetry towards the rear and sideways up to an apex line, by surfaces connecting smoothly thereonto in that location and descending in a symmetrical and convex fashion rearwards and towards the sides.

*FOR THE PURPOSES OF INFORMATION ONLY*

Codes used to identify States party to the PCT on the front pages of pamphlets publishing international applications under the PCT.

AT	Austria	GB	United Kingdom	MR	Mauritania
AU	Australia	GE	Georgia	MW	Malawi
BB	Barbados	GN	Guinea	NE	Niger
BE	Belgium	GR	Greece	NL	Netherlands
BF	Burkina Faso	HU	Hungary	NO	Norway
BG	Bulgaria	IE	Ireland	NZ	New Zealand
BJ	Benin	IT	Italy	PL	Poland
BR	Brazil	JP	Japan	PT	Portugal
BY	Belarus	KE	Kenya	RO	Romania
CA	Canada	KG	Kyrgystan	RU	Russian Federation
CF	Central African Republic	KP	Democratic People's Republic of Korea	SD	Sudan
CG	Congo	KR	Republic of Korea	SE	Sweden
CH	Switzerland	KZ	Kazakhstan	SI	Slovenia
CI	Côte d'Ivoire	LI	Liechtenstein	SK	Slovakia
CM	Cameroon	LV	Latvia	SN	Senegal
CN	China	LK	Sri Lanka	TD	Chad
CS	Czechoslovakia	LU	Luxembourg	TG	Togo
CZ	Czech Republic	LV	Latvia	TJ	Tajikistan
DE	Germany	MC	Monaco	TT	Trinidad and Tobago
DK	Denmark	MD	Republic of Moldova	UA	Ukraine
ES	Spain	MG	Madagascar	US	United States of America
FI	Finland	ML	Mali	UZ	Uzbekistan
FR	France	MN	Mongolia	VN	Viet Nam
GA	Gabon				

Anchor fluke

The invention relates to an anchor fluke having having a penetration or front edge and a rear edge, and a longitudinal plane of symmetry intersecting these edges, comprising means for attachment of connecting means to a penetration- anchor line.

It is an object of the invention to provide an anchor fluke having a stable and favourable penetration behaviour.

10

It is moreover an object of the invention to provide an anchor fluke and anchor having a great holding force relative to the weight.

15 It is furthermore an object of the invention to provide an anchor that is very suitable to be included in vertical anchoring systems.

According to the invention an anchor fluke is provided, having a penetration or front edge and rear edge and a longitudinal plane of symmetry intersecting these edges, comprising means for attachment of connecting means to a penetration-anchor line, the fluke having an upper side which, in a portion connecting to the front edge, extends from that front edge according to a convex path which ascends in longitudinal direction and extends there, in both areas of the front portion situated on either side of the longitudinal plane of symmetry, according to paths that ascend in transverse direction in a direction away from the plane of symmetry.

30

- 2 -

It has been found that an anchor fluke having such a shape can quickly and in a stable manner penetrate to a large depth. Although applicant does not wish to confine himself to that reasoning, he suspects that the stability is aided  
5 by the presence on both sides of the longitudinal plane of symmetry of convex faces ascending rearwards and side-wards, so that the soil which moves along the fluke (seen relatively) can exert a reversely outwardly sideward directed force on the upper surface of the fluke, and can  
10 readily be pulled into the soil in longitudinal direction as a consequence of the convex shape.

It is preferred that the path which ascends in transverse direction is also convex.

15

It is preferred that the front edge of the fluke, on both sides of the longitudinal plane of symmetry, has a front edge which runs in an oblique direction towards the front from that plane, said front edge merging in a foremost  
20 penetration-point into a side edge which extend substantially along the side of the fluke towards the rear edge. The front portion of the upper side of the fluke herein ascends in a convex manner from the front edges, in a direction substantially perpendicular to the front edges.  
25 The sideways and convexly ascending portions herein extend preferably upto a foremost portion of the outer or side edges. Thus it is achieved that a significant part of the front portion of the upper surface of the fluke ascends outwards and sidwards from the longitudinal plane of  
30 symmetry, and that on that front portion of the upper surface of the fluke, the surfaces are only directed in two main directions, with a transverse component having an opposite direction which, as is nonetheless supposed, has a stabilising effect and also gives the fluke a smooth  
35 shape.

The upper surface of the fluke is preferably shaped in

- 3 -

such a way, that the ascending convex front portion of the upper surface of the fluke merges into a convex, descending portion, the rear portion. Thus, the upper surface of the fluke will comprise a portion, which will have hardly  
5 any influence on the penetration during penetration of the anchor fluke, that is to say will not hamper this penetration, but will contribute to the weight, and which can be active in a vertical anchoring system after the anchor fluke has penetrated sufficiently.

10

Vertical anchoring usually takes place with TLP's, by means of tie rods and very expensive piles, for which ever more advanced driving equipment has to be developed as a result of the great water depth. Another possibility is to  
15 shoot the anchors into the ground, after which the anchors position themselves horizontally if one exerts a vertical force on them. The solutions required for this purpose have many environmental drawbacks.

20 As a consequence of the upper surface of the fluke being curved at least in longitudinal cross section, having an apex in the curve which is situated on the upper surface, for instance in the centre of gravity of the surface, the anchor fluke is substantially kept in place when a force  
25 in vertical direction is exerted thereon, due to the earth pressure, which will be directed both towards the front and towards the rear.

The convex arch-shape continued in downward direction on  
30 the upper/rear side of the fluke, diverging from the plane of symmetry, also contributes to the stabilization of the fluke, both during penetration and during use in a vertical anchoring system.

35 The top line connecting the ascending and descending convex areas can intersect the longitudinal plane of symmetry preferably in the area of the fluke. Both top

- 4 -

lines, each to one side, preferably diverge away from each other forwardly. It is preferred that they intersect the outer or side edges. It is moreover preferred that they slope downwards somewhat from the longitudinal plane of symmetry, while extending outwards and forwards. In this way, the areas of the upper surface of the fluke will be situated relatively highest near the longitudinal plane of symmetry, so that in that location the anchor fluke can have a greatest thickness and as a consequence thereof a greatest strength.

A further preferred embodiment is described in claim 12. As a result of these measures, the upper surface of the fluke will slope downwards in the area near the edge between the point of intersection of the top line and the side edge and the point of the greatest width. The lower surface of the upper side of the fluke will then offer a surface area to the soil that is directed forwards and is ascending. Actually, a stabilizer is hereby provided as described in European patent specification no. 049.455 in the name of applicant.

The anchor fluke according to the invention preferably comprises a bottom side, having a convex course in transverse cross section, that is of which the concave side is directed downwards. Thus, the anchor fluke is given a twin plated, forwardly bending shape in longitudinal cross section, which is particularly advantageous for the penetration behaviour.

Preferred embodiments of the bottom side of the fluke are described in the enclosed claims 14, 15, 16 and 17.

It is preferred that the bottom side of the fluke extends in rearward direction beyond the upper side of the fluke in order to thus form a slopingly upwardly and rearwardly directed flat plate stern. This prevents the formation of

- 5 -

too great an underpressure near the upper rear edge of the fluke, which underpressure would otherwise bring about an upwardly tilting moment in forward direction. Moreover, a flat plate stern having such an orientation is advantageous in vertical anchoring systems, because the flat plate stern then presses against a body of soil situated above it and thus contributes to the holding force of the anchor in the vertical anchoring system.

10 In other words, the invention relates to an anchor fluke, comprising a bottom side and an upper side and a longitudinal plane of symmetry, the upper side being defined by two convexly bent surfaces, formed by surfaces ascending in a convex manner from the sharp front edge in a symmetrical fashion relative to the longitudinal plane of symmetry towards the rear and sideways upto an apex line and by surfaces connecting smoothly thereonto in that location and descending rearwards and sideways in a symmetrical and convex fashion. Herein the front edge is preferably V-shaped, while the front edge and the connecting front portions of the outer edges, can together define a W-shape in top view.

It is remarked that from Dutch patent application 76.08728 an anchor is known, which is particularly suitable for anchoring in muddy soil and is provided with a shank structure formed by a number of rods and with a fluke which, seen in vertical longitudinal cross section, has a convex shape at the top and at the bottom. Seen in transverse cross section, however, this fluke runs straight on the upper and on the bottom side. In order to provide the known anchor with sufficient course stability, stabilizer plates have been arranged for that purpose on both sides of the fluke. Although these plates function satisfactorily, they also increase resistance against anchor penetration.

- 6 -

It is further remarked that from US patent specification 4.781.142 an anchor is known, comprising a rigid shank and a fluke, wherein the fluke comprises two fluke halves situated on both sides of the longitudinal plane of symmetry, each tapering, from rear to front, both in transverse and in downward direction to a front point. The fluke halves are herein composed of a number of flat plate members, merging into one another via sharp lines or buckle lines, so that the fluke halves have an angular appearance in transverse cross section. On the rear edge of the fluke the fluke halves end with their rearwardly ascending surfaces in a cross-plate, projecting in side-wards direction from the upper surface and thus forming stabilizer surfaces. These surfaces which are perpendicular to the direction of penetration hamper the penetration of the anchor.

The application moreover relates to an anchor comprising a fluke and a shank, formed by at least one pair of wires, lines or stays, such as cables or chains, attached onto the fluke with their lower ends at locations which are spaced from each other in longitudinal direction of the fluke and being connected to a coupling mechanism with their upper end at locations spaced from each other, said coupling mechanism being itself provided with means for connection to a penetration-anchor line, the coupling mechanism being provided with means, operated by remote control, for displacing or adjusting the upper ends of the shank wires relative to each other.

The advantage of such an anchor is that the non-rigid shank, and with it the penetration-anchor line, can be adjusted under several angles relative to the penetrated fluke. When the anchor, after having served its purpose, is no longer required at a certain location and when it is desirable to use the same anchor at a different location, the angle between shank and fluke may be enlarged and the

- 7 -

penetration-anchor line, which has also been used for the anchoring, can be brought into for instance a more vertical position, in which a tensile force exerted on the anchor line results in the fluke moving in an obliquely upwards direction through the anchoring soil, until the fluke leaves the anchoring base. It will also be possible, after penetration of the fluke in the anchoring base, to swing the shank wires and with this the shank relative to the fluke in such a way, that the fluke is suitable to take part in a vertical anchoring system. For this purpose the fluke need not be adapted, yet some provisions need to be made between the upper ends of the shank wires and the lower end of the penetration-anchor line, that is to say in the coupling mechanism.

The anchor preferably comprises a coupling mechanism, having a movable connecting member, such as one or more oblong, parallel plates, wires or chains, to which the upper ends of both shank wires have been secured and comprising displacement means for swinging the connecting member in a vertical plane.

The operatable means preferably comprise two flexible connecting lines of unequal length, being connected with their lower ends to the connecting member at locations that are spaced from each other, and being connected with their upper ends to a coupling member at locations that are displaceable relative to each other in direction of pull by means of remote control means, said coupling member being itself connected with its upper end to the lower end of the penetration-anchor line.

The coupling member herein preferably comprises two or more female spaces or seats, which open substantially in the direction of pull, away from the fluke, and are spaced in direction of pull and in which a male member, such as a pin or cam, situated on or near the upper end of the

- 8 -

longest connecting line, may come to rest in a removable manner, the operating means being adapted to control the position of the male member.

- 5 The remote control means can comprise an auxiliary line, put around a pin, to be put into the seat by means of for instance a thimble.

An advantageous, compact and simple embodiment of the  
10 coupling mechanism according to the invention is one in which the movable connecting member comprises a first connecting part and a second connecting part, being hingedly connected to each other on one end and being connected to each other on their other end by means of a  
15 connection which can be disconnected by means of remote control means, the first connecting part being provided with the means for connection with the penetration-anchor line and the second connecting part being provided with means, being spaced from each other, for connection with  
20 the upper ends of the shank wires. By disconnecting the two connecting parts on their one end they can, under continued pull on the penetration anchor line, as it were swing open relative to each other into for instance a mutual angle of 180°. During this movement, the location  
25 of the means for connection with the upper ends of the shank wire will be interchanged and thereby the angle of the shank relative to the fluke.

Preferably, the first connecting part and/or the second  
30 connecting part are herein formed by an oblong plate or plates.

Preferably, the disconnectable connection is formed by a tenon and mortise connection, the tenon being connected to  
35 the lower end of an auxiliary line. By simply pulling the auxiliary line, the tenon is removed from the connection and the first and second connecting parts can jump open.

- 9 -

In order to have more possibilities in the choice of the shank angle prior to paying out the anchor, the second connecting part is preferably provided with more than two interspaced means for connection with the upper ends of  
5 the shank wires.

The invention will now be described in more detail on the basis of the embodiments of an anchor fluke according to the invention and the coupling mechanism according to the  
10 invention, both shown in the accompanying figures and both serving merely as examples. The following is shown in:

figure 1: a top view of an exemplary embodiment of an anchor fluke according to the invention, provided with a  
15 shank made up of wires;

figure 2: a top view on an exemplary embodiment of the anchor fluke according to the invention, wherein at a number of locations, the vertical longitudinal cross  
20 sections have been shown, as well as the bending lines for the upper surface and the bottom surface of the anchor fluke;

figure 3: a top view on one half of a further exemplary embodiment of the anchor fluke according to the invention,  
25 wherein some bending lines and some longitudinal cross sections have been represented;

figure 4: shows a number of transverse cross sections  
30 according to the lines indicated in figure 3;

figure 5: a girder and sleeper diagram of an embodiment of an exemplary embodiment of the anchor fluke according to the invention;

35

figure 6A-C: the starting position, the intermediate position and the final position of a coupling mechanism accor-

- 10 -

ding to the invention, with which the angle of a stay shank may be changed relative to an anchor fluke;

figure 7: a schematic representation of the penetration of  
5 a fluke and the adjustment thereof for a vertical-anchoring system for a TLP, wherein use can be made of the coupling mechanism of figures 6A-6C;

figure 8A-8C: some views of the coupling member of the  
10 example of a coupling mechanism according to the invention represented in figures 6A-6C; and

figure 9A en 9B: the folded and the extended position,  
15 respectively, of an alternative embodiment of the coupling mechanism according to the invention.

Figure 1 shows an anchor according to the invention, having a fluke 2, comprising a front edge 3 and a rear edge 4 and side edges 6, which edges form the boundaries  
20 for the upper plate 14. A bottom plate 15 is situated on the bottom side. It is remarked that these plates need not be formed as a whole, but may be composed of several plate members. The fluke 2 is reinforced by means of two longitudinal girders 13 represented by dashed lines, said  
25 longitudinal girders running from the rear edge 4 to the front edge 3, and ending on the front edge in penetration points 5. The retracted front edge 3 of the fluke 2 is V-shaped, the tip of the V being directed towards the rear, so as to provide the penetration points 5.

30

The anchor 1 moreover comprises a shank built up of two pairs of wires 7, 8, attached to the fluke 2 at locations 9 and 10, respectively. On their other end, the wires 7, 8 are joined together at connecting member 11, to which an  
35 attaching eye 12 is also secured to which a penetration-anchor line (not shown) can be attached to let the anchor penetrate into the soil.

- 11 -

The fluke 2 represented in figure 1 is symmetrical relative to the longitudinal plane of symmetry S, said plane extending perpendicular to the plane of the drawing.

5 In figure 2 one of both symmetrical halves of the fluke 2 of figure 1 is depicted, wherein the vertical longitudinal cross sections in the planes A, B, C, D, E and F extending parallel to the longitudinal plane of symmetry S have been schematically represented.

10

Furthermore, figure 2 shows the bending lines or generatrices of the upper plate 14 and the bottom plate 15. The generatrices of the upper plate 14 are indicated with reference numeral 16, the highest generatrice 16' intersecting the side edge of the upper plate 14 at R and intersecting the longitudinal plane of symmetry S at location P. In figure 2, the generatrices 16 extend parallel and are positioned on a cylinder surface, although this is not strictly necessary. It can be seen that at the front the generatrices coincide with the front edge 3, so that the portion of the upper plate 14 situated between the line RP, the side edge 6, the front edge 3 and the longitudinal plane of symmetry S is curved upwards in the direction V, perpendicular to the front edge 3. This front area of the upper plate 14, together with the corresponding area of the other half of the fluke, forms a striking plane for the soil during penetration of the anchor, said meeting plane ascending convexly and diverging in two directions V, V'.

30

In the rear area, bounded by the line R, P, the plane of symmetry S, the rear edge 4 and the side edge 6, the upper plate 14 continues to curve downwards in a convex manner and sideways in the direction V. As a result, not only the stability during penetration is further improved, but the lateral stability of the anchor fluke during use in vertical anchoring systems is enhanced.

35

- 12 -

In figure 2 it can be seen that at the location of the point R the side edge 6, seen from left to right in the drawing, merges from a upwardly curved course into a downwardly curved course. As a consequence, an area on the bottom side of the upper plate 14, bounded by the side edge 6, situated in the direction of penetration behind the point R, may form a surface that is oriented downwards and in the direction of penetration. This will be discussed in more detail below.

10

In figure 2 moreover, the generatrices of the bottom plate 15 have been indicated. Herein, two areas can be distinguished, namely the central area between both longitudinal girders 13 and the area to the sides of and outside the longitudinal girders 13.

In the area between the longitudinal girders, seen (for the half of the fluke represented in figure 2 that is the area on the drawing below the longitudinal girder 13), the bottom plate 15 is bent only in longitudinal direction. The generatrices or bending lines 17 are therefore positioned perpendicular to the plane of symmetry S and to the longitudinal girders 13.

25 In the greater part of the area outside the longitudinal girders 13 the bottom plate 14 is bent convexly both in longitudinal direction and in transverse direction. The bending lines or generatrices 18 herein define an angle with the longitudinal plane of symmetry S which is larger than that of the bending lines 16 of the upper plate 14. In this outer area of the bottom plate 15, a transition takes place in the direction of bending in the rear area, so as to achieve that the portion of the side edge 6, behind the point of the largest width, point 19, is sharp.

30 It can be seen that the upper plate 14 and the bottom plate 15 meet along the front edge 3 and the side edge 6 so as to form a sharp edge, which promotes penetration.

- 13 -

As has already been indicated above, the upper plate 14 extends downwards in rearward direction in the edge area behind point R, and it can be seen that, between the area bordering on the side edge 6, between points R and 19, starting from the sharp side edge 6 and from a convexly bent course of the bottom plate 15, the bottom plate 14 forms a plane directed downwards and towards the front, which plane may serve as a stabilizer.

Figure 3 shows a somewhat altered shape of the anchor fluke according to the invention. Again, one of the symmetrical halves of the fluke 102 is shown. The fluke 102 has a front edge 103, a side edge 106 and upper rear edge 104a and bottom rear edge 104b, the front edge 103 and the side edge 106 meeting at the front in penetration point 105. The upper rear edge 104a is situated forwards from the bottom rear edge 104b, so that a flat plate stern 117, extending slopingly upwards, is formed, which can contribute to the holding force of the fluke in vertical anchoring systems. Moreover, this position of the flat plate stern improves the penetration behaviour. A longitudinal girder 113 extends towards the back from the penetration point 105, parallel to the the longitudinal plane of symmetry S. Depicted are the generatrices or bending lines 116 of the top plate 114. The highest bending line 116' extends between the point of intersection with the longitudinal plane of symmetry S, P', and the point of intersection of that line with the side edge 106, R'. In the area situated in front of the line P' R' in the direction of penetration, the upper surface of the fluke 102 is shaped in a convexly curved manner both inwards and towards the front. At the front edge, the lines 116 coincide with the front edge 103 and they subsequently, going towards the rear, do not extend parallel, but in this example are situated on a conical surface, the centre line of which is located in a plane which is perpendicular to the plane of the drawing and extends from an area to the

- 14 -

right below the plane of the drawing to an area to the left above the plane of the drawing. The point P' is situated higher than the point R'. The upper plate 114 therefore has its greatest height at the location of the point P'.

Figure 3 also shows some vertical longitudinal cross sections, namely along the faces H, I and J. The face H coincides with the plane of symmetry S and the face I comprises the longitudinal girder 113. In the longitudinal cross sections it is special that herein the position is shown, which is taken up by the fluke when it is placed on a flat base. The fluke is then resting with its rear edge 120 of the bottom plate 115 and the penetration point 105, as well as the longitudinal girder 113 on the flat base. This can be seen clearly in cross section I. The longitudinal cross sections clearly show the smooth and sharp appearance of the fluke according to the invention. In cross section H, the great distance can be seen between the upper plate 114 and the bottom plate 115 near the point P'. Moreover, it can also be seen that the rear side is cut off, to define a flat plate stern 117 between the edges 104a and 104b. In cross section I, the course of the side edge 106 has also been shown by way of illustration.

The bottom plate 115 is always formed in a concavely curved manner in longitudinal direction, and in transverse direction substantially in accordance with the bottom plate 15 shown in figure 2. In figure 4, this has been further illustrated by means of transverse cross sections K, L, M and N. These cross section are taken along faces perpendicular to the plane of the drawing of figure 3.

The straight course in transverse cross section of the bottom plate 115 in the area between the plane of symmetry S and the longitudinal girders 113 can be seen clearly. In

- 15 -

the area outside the longitudinal girders 113, the bottom plate 115 is bent concavely in a smooth manner to meet the upper plate 114 in a sharp side edge 106.

- 5 In cross section K, the convexly curved shape, ascending laterally, of the upper plate 114 can be seen clearly.

The point of the convexly curved bottom side is that the anchor now rest on the ground at the front and at the rear and that the tip thereof is as it were thrust into the ground when the anchor is pulled. At the rear, the upper plate of the anchor descends outwardly in a curved manner to form stabilizer faces, and thereby provides dynamic penetration stability.

15 Because the fluke has been given a highly streamlined shape and because no separate stabilizers are present to prevent the penetration, the anchor fluke according to the invention has very good penetration characteristics. Added to that, a fixed shank is also lacking in the anchor equipped with the anchor fluke according to the invention (as shown in figure 1), a relatively light anchor is provided in comparison with the obtained surface of the fluke. Although this anchor is light, it will nevertheless be able to provide a great holding force, especially when used in vertical anchoring systems.

In general, it can be said that such an anchor, as a consequence of an almost identical curve in longitudinal direction of the upper plate and the bottom plate, with almost no further resistance from stabilizers and shanks, will continuously tend to continue in that same curve during penetration, counter to the negative tensile forces of the penetration anchor line. Stability is herein promoted by the front portion of the upper side of the fluke, namely the upwardly and convexly curved surfaces which run away from each other, and the rear portion of the upper

- 16 -

face of the fluke smoothly connecting thereto, where the convexly curved surfaces run downwards and away from each other.

5 In figure 5, the frame of a preferred embodiment of the fluke according to the invention has been represented. The girders 413a, b are herein arranged in a manner somewhat converging in forward direction. On the front, two sleepers Q1a and Q1b are connected to the girders 413a, b.  
10 Behind that, two sleepers Q2a and Q2b are arranged, attached with their inner ends to the front end of the middle girder 413c. The middle girder 413c is situated in the plane of symmetry of the fluke. Further towards the back, sleepers Q3, Q4, Q5, Q6, Q7 and Q8 are arranged suc-  
15 cessively at equal distances from each other, and at the rear side the face of the flat plate stern 417 is shown schematically, attached onto the oblique end edges 418a, 418b and 418c of girders 413a, 413b and 413 c, respec-  
20 tively. It should be understood that the upper side and the bottom side of the fluke are formed by curved or slightly buckled plates, which are attached against the upper edges and the lower edges of the sleepers, respec-  
25 tively, and therefore follow the course thereof in transverse direction. The relatively strong curve of the portion behind the top line pr, behind which the rear portion, bent towards the rear and sideways, of the upper face of the fluke will be situated, can be seen clearly. It can moreover be seen that in areas in the plane of symmetry which are situated more towards the rear, both  
30 halves of the upper surface meet according to a discontinuity. It can also be seen that, in the central area of the bottom side, as a consequence of the shape of the lower edge of the sleepers, the bottom surface of the fluke will extend somewhat downwards from the middle in  
35 lateral direction, so as to improve stability.

Figures 6A-6C show the mechanism according to the appli-

- 17 -

cation by which, in case of a penetrated fluke, the shank angle relative to the fluke can be altered by means of remote control. The anchor as shown here comprises a fluke 200, to which a pair of front shank cables 202 and a pair of rear shank cables 203 have been attached with their lower ends. The upper ends 205 and 206 of the pairs of shank wires 202 and 203, forming the non-rigid shank 201, are rotatably attached to a connecting plate 204. This connecting plate 204 is provided with two eyes, in which two shackles 207 and 208 have been secured. The upper ends 205 and 206 of the shank cables 202 and 203 can be attached to the pins of these shackles by means of thimbles. The lower ends 211 and 213 of parallel connecting cables 209 and 210 are attached to the shackles 207 and 208. The connecting cable 210 is herein longer than the connecting cable 209.

A coupling member 220 is situated above the cables 209 and 210, said coupling member comprising a plate assembly 221 and a movable coupling element 222. The plate assembly 221 comprises two parallel plates 230a, 230b (see also figures 8A-8C) and is provided with seats or notches 232 and 233, situated at a distance of each other in the direction of pull or anchor line main direction. On the bottom side of the plate assembly 221 the thimble 212 is attached to the upper end of the connecting line 209 by means of a pin 225 and shackle 226. The lower end of the penetration-anchor line 230, in the shape of thimble 231, is attached to the upper end of the plate assembly 221 by means of pin 226 and shackle 228.

The displacable coupling member 222 here consists of two parallel plates 222a and 222b, connected to each other by means of an upper pin 224 and a lower pin 223. The distance between these two pins 223 and 224 is such, that the coupling member 222 can shift over the plate assembly 221. On its upper end, the connecting cable 210 is attached

- 18 -

with thimble 214 to the pin 223 and thereby to the coupling member 221.

Figure 8A shows the plate assembly 221 and the coupling member 221 separately in side view. In figure 8B, both parts are shown in perspective, but now in the position, in which the coupling member rests in the seat 232. Figure 8C provides a front view of both parts with shackles, the coupling member resting in the seat 233.

10

In the situation represented in figure 6A, the upper pin 224 of the coupling member 221 rests in the lower seat 231 and, as a consequence of the ratio in length between the connecting cables 209 and 210, only the connecting cable 209 is taut. The tensile force is consequently transferred from anchor line 230, to the plate assembly 221, to connecting cable 209 and from there to the connecting plate 204. In figure 6A, the anchor has a configuration in which it is suitable to be pulled into sandy soils. The situation in figure 6A will thus occur during penetration. For this purpose, reference can also be made to the sketch of figure 7, in which it can be seen how the fluke 200 is pulled into the soil 300 by the penetration-anchor line 230, along the path 301. On the right-hand end of this path 301 the situation shown in figure 6B has been achieved. Then, the auxiliary cable 234 is pulled, of which the lower end 235, in this case a thimble, is attached to the pin 224 of the coupling member 222. By pulling the auxiliary cable 234, for instance from the object to the anchored or from an auxiliary vessel, the pin 224 will be pulled up out of the seat 233 and can then be pulled up along the side edges of the plates 230a, 230b into seat 232. The auxiliary cable 232 is herein advantageously guided by the shackle 228. When the pin 224 is moved upwards, the coupling member 222 will be moved upwards over and around plate assembly 221 and thereby also the pin 223. As a result, the connecting cable 210 will become

- 19 -

taut and exert a tensile force on, seen in the drawing, the left-hand portion of the connecting plate 204, so that the latter will twist clockwise. Herein a tensile force is also exerted in the rear shank cables 203, so that the fluke will also be rotated clockwise, which has been schematically represented on the right-hand side of figure 7.

Finally, the situation represented in figure 6C is achieved, in which the pin 223 has come to rest in the seat 232 and the fluke has attained an ideal position for a vertical anchoring system as in figure 7 for the TLP 302. By means of the cables 230, the TLP 302 is pre-tensioned relative to the water-level 303.

15

If desired, the pin 224 can also be connected to an auxiliary line, extending to the floating object. By means of this auxiliary line, not shown, the coupling member 222 may be lifted on the left-hand side, after the anchor line 230 has been relaxed somewhat, in order to achieve the exit of the pin 223 out the seat 232, the result of that being that the pin 224 is once again brought into the seat 233 by means of the tensile force exerted on the anchor line 230. In this position, pulling the fluke 200 out of the soil is made easier.

In figures 9A and 9B, an alternative embodiment of the coupling mechanism according to the invention has been shown. The coupling mechanism 500 is herein formed by an oblong plate 501 and two parallel plates 502, hingeably connected to each other by means of hinges 505. The plate 501 herein fits between both plates 502. The depiction of figure 9A should be considered as a midsection.

On the upper end the plate 501 is connected to shackle 504 by means of pin 503, a penetration anchor line being attached to said shackle. On that same end, the plates 501

- 20 -

and 502 are also attached to each other, by means of an eye pin 508 projecting through a hole in transverse plate 506, which transverse plate connects both plates 502, and a hole provided in a transverse plate 507 in a plate 501, 5 said eye pin being secured with breaking pin 519. A shackle 509 is attached to the eye of eye pin 508, to which shackle in its turn the thimble-shaped lower end of auxiliary line 510 is attached.

10 Both plates 502 are also connected to each other by means of transverse pins 511, 512 and 513. Thimbles 514 and 515 have been placed around two of these transverse pins, which are therefore confined in lateral direction by both plates 502. Thimble 514 is the upper end of shank wire 517 15 and thimble 515 is the upper end of shank wire 518. It will be understood that these shank wires represent pairs of shank wires and are attached at the front and the rear respectively of the fluke of the anchor (not shown).

20 When now, after sufficient penetration of the anchor, the auxiliary line 510 is pulled, the pin 508 will be pulled out of the holes in the parts 506 and 507, as a result of which the connection present on that end of the plates 501 and 502 will be released. A tensile force exerted in the 25 direction of the arrow in figure 9A by the penetration-anchor line on the shackle 504 will result in the breaking of the breaking pin 510 and in the plates 501 and 502 moving away from each other around hinge 505. Finally, the situation represented in figure 9B is achieved, in which 30 the transverse pin 511 and therewith the thimble 514 are now situated higher than the transverse pin 512 and the thimble 515.

SM

C L A I M S

1. Anchor fluke having a penetration or front edge and a rear edge and a longitudinal plane of symmetry intersecting these edges, comprising means for attachment of connecting means to a penetration anchor line, the fluke  
5 having an upper side which, in a front portion connecting to the front edge, extends from that front edge according to a convex path which ascends in longitudinal direction and extends there, in both areas of the front portion situated on either side of the longitudinal plane of sym-  
10 metry, according to paths that ascend in transverse direction in a direction away from the plane of symmetry.
2. Anchor fluke, wherein said front portion ascends in both transverse directions according to a convex path.  
15
3. Anchor fluke according to claim 1 or 2, wherein, on both sides of the longitudinal plane of symmetry, the front edge of the fluke has a front edge which runs in an oblique direction towards the front from that plane, said  
20 front edge merging in a foremost penetration point into a side edge which extends substantially along the side of the fluke towards the rear edge.
4. Anchor fluke according to claim 3, the front portion of  
25 the upper side of the fluke ascending in a convex manner from the front edges, in a direction substantially perpendicular thereto.
5. Anchor fluke according to claim 4, wherein the front  
30 portion of the upper side extends upto a foremost portion

- 22 -

of the side edges.

6. Anchor fluke according to claims 3, 4 or 5, the front  
portion of the upper side of the fluke ascending in a  
5 convex manner from the front edges in two rearwardly  
diverging directions, in a symmetrical manner relative to  
the longitudinal plane of symmetry.

7. Anchor fluke according to any one of the preceding  
10 claims, the convexly ascending front portion of the upper  
side of the fluke merging into a descending convex rear  
portion of the upper side of the fluke via top lines  
extending from a point of intersection situated in the  
longitudinal plane of symmetry.

15

8. Anchor fluke according to claim 7, the top lines exten-  
ding on both sides of the longitudinal plane of symmetry  
intersecting at a point situated on the fluke when seen in  
a top view.

20

9. Anchor fluke according to claim 7 or 8, both top lines  
extending on both sides of the longitudinal plane of  
symmetry sloping downwards from the plane of symmetry.

25 10. Anchor fluke according to claim 7, 8 or 9, both top  
lines situated on both sides of the longitudinal plane of  
symmetry diverging from each other towards the front.

11. Anchor fluke according to anyone of the claims 7 -  
30 10, both top lines extending on both sides of the longi-  
tudinal plane of symmetry intersecting the outer or side  
edges of the fluke.

12. Anchor fluke according to claim 11, the side edges, as  
35 seen in top view on the fluke, being curved so that the  
fluke, going from the front edge towards the rear edge,  
first becomes wider until a maximum width and then becomes

- 23 -

narrower towards the rear edge, the top lines extending on both sides of the longitudinal plane of symmetry intersecting the outer or side edges at a point situated in front of the maximum width.

5

13. Anchor fluke according to any one of the preceding claims, the fluke furthermore having a bottom side extending substantially correspondingly to the upper side in longitudinal cross section, that is extending concavely.

10

14. Anchor fluke according to claim 13, comprising two longitudinal girders, arranged on both sides of the longitudinal plane of symmetry, wherein in the area between the longitudinal girders, the bottom side of the fluke has a concave course in transverse cross sections.

15

15. Anchor fluke according to claim 13, wherein, in the areas outside the longitudinal girders, at least a front portion of the bottom side of the fluke has a concave course in longitudinal direction and a sideways outward direction.

20

16. Anchor fluke according to claim 14, the generatrices or the bending lines of the area of the bottom side of the fluke situated outside the longitudinal girders being at a sharp angle relative to the longitudinal plane of symmetry, said angle being larger than the corresponding angle of the bending lines of the upper side of the fluke in the portion situated above it.

25  
30

17. Anchor fluke according to claim 13, the bottom side having a concave course in the transverse cross sections.

18. Anchor fluke according to any one of the preceding claims, the bottom side of the fluke extending in rearward direction beyond the upper side of the fluke to form a slopingly upwardly and rearwardly extending flat plate

35

stern.

19. Anchor fluke comprising a bottom side and an upper side and a longitudinal plane of symmetry, the upper side  
5 being defined by two convexly bent surfaces, formed by faces ascending in a convex manner from the sharp front edge in a symmetrical fashion relative to the longitudinal plane of symmetry towards the rear and sideways upto an apex line and by surfaces connecting smoothly thereonto in  
10 that location and descending in a symmetrical and convex fashion rearwards and outwards, towards the sides.

20. Anchor fluke according to claim 19, the front edge being V-shaped.

15

21. Anchor fluke according to claim 20, the front edge and the connecting front portions of the outer edges defining a W-shape in top view.

20 22. Anchor, comprising a fluke and a shank, formed by at least one pair of wires, lines or stays, such as cables or chains, attached onto the fluke with their lower ends at locations which are spaced from each other in longitudinal direction of the fluke and said cables or chains being  
25 connected to a coupling mechanism with their upper end at locations spaced from each other, said coupling mechanism being itself provided with means for connection to a penetration anchor line, the coupling mechanism being provided with means, operable by remote control, for dis-  
30 placing or adjusting the upper ends of the shank wires relative to each other.

23. Anchor according to claim 22, comprising a coupling mechanism, which comprises a movable connecting member,  
35 such as one or more oblong, parallel plates, wires or chains, to which the upper ends of both shank wires have been secured and comprising displacement means for swing-

- 25 -

ing the connecting member in a vertical plane.

24. Anchor according to claim 23, the operable means preferably comprising two flexible connecting lines of  
5 unequal length, being connected with their lower ends to the connecting member at locations that are spaced from each other, and being connected with their upper ends to a coupling member at locations that are displaceable relative to each other in direction of pull by means of remote  
10 control means, said coupling member being itself connected with its upper end to the lower end of the penetration-anchor line.

25. Anchor according to claim 24, the coupling member comprising two or more female spaces or seats, which open  
15 substantially in the direction of pull, away from the fluke, and are spaced in direction of pull and in which a male member, such as a pin or cam, situated on or near the upper end of the longest connecting line, may come to rest  
20 in a removable manner, the control means being adapted to control the position of the male member.

26. Anchor according to claim 25, the control means comprising an auxiliary line, put around a member, such as  
25 the pin, to be put into the seats by means of for instance a thimble.

27. Anchor according to claim 23, the movable connecting member comprising a first connecting part and a second  
30 connecting part, being hingedly connected to each other on one end and on their other end being connected to each other by means of a connection which can be disconnected by means of remote control means, the first connecting part being provided with the means for connection with the  
35 penetration-anchor line and the second connecting part being provided with means, being spaced from each other, for connection with the upper ends of the shank wires.

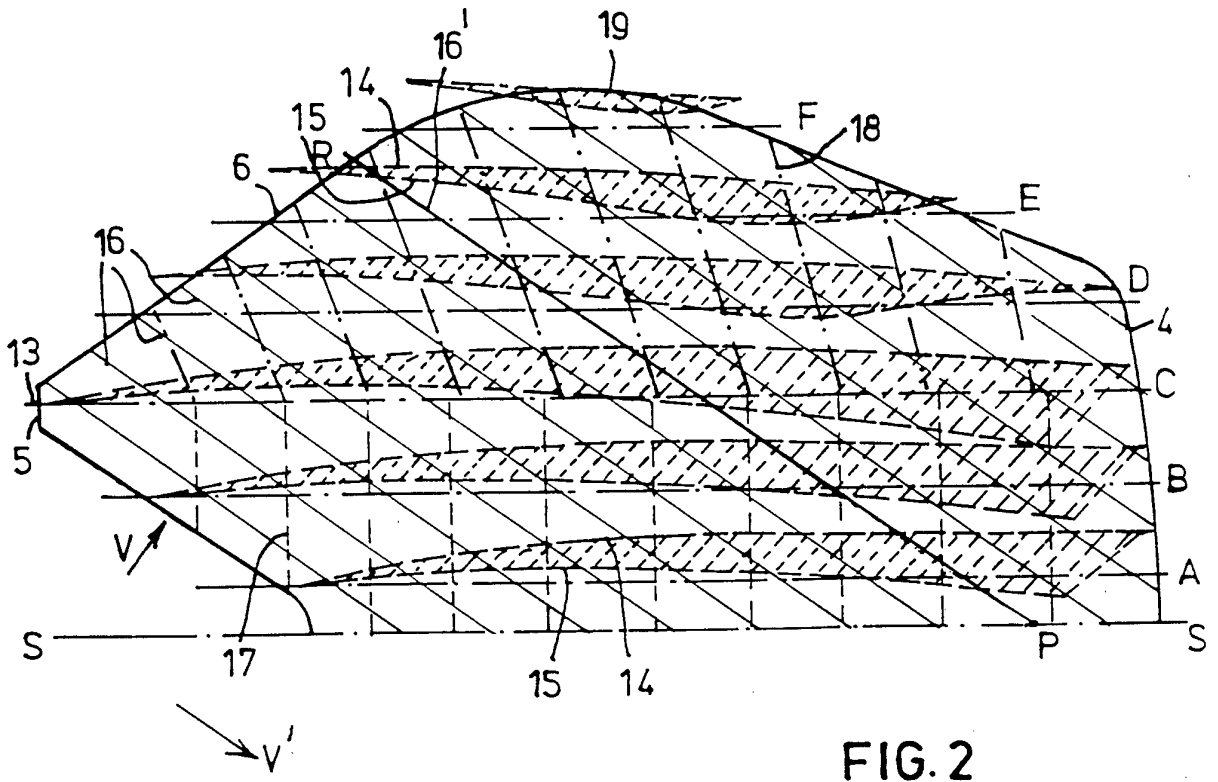
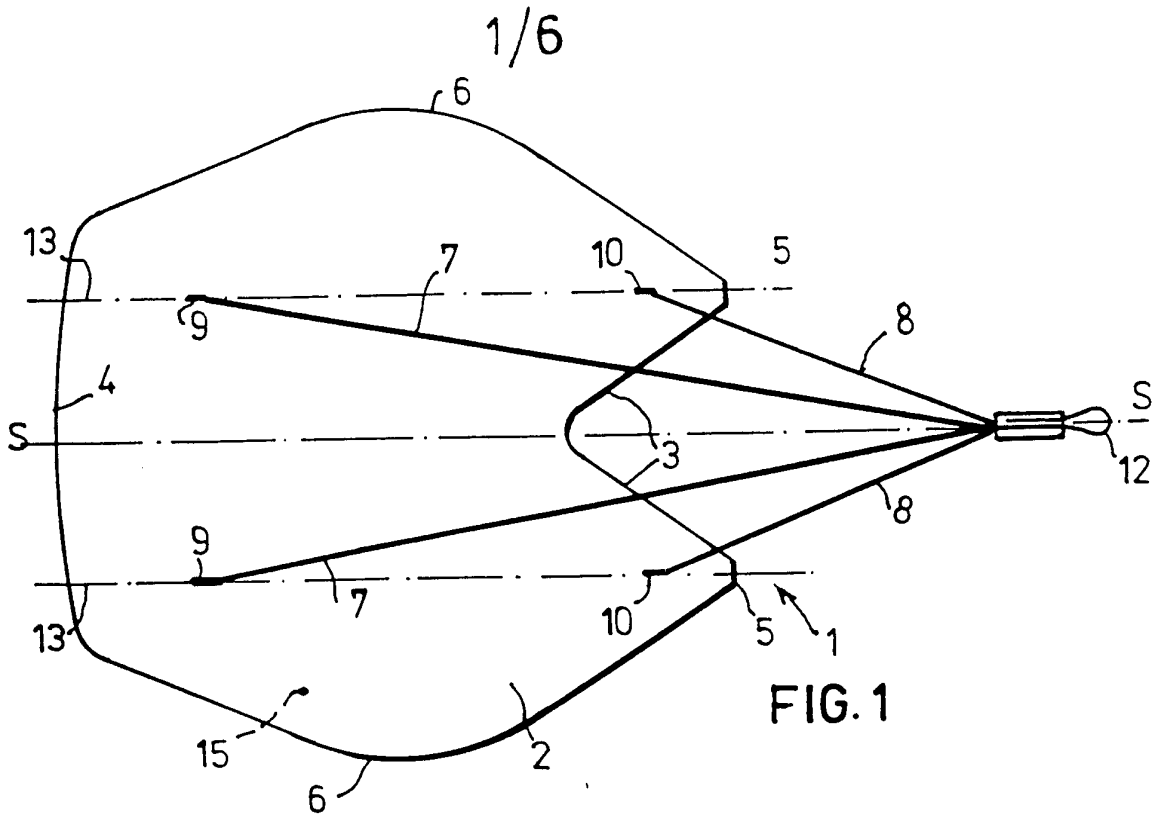

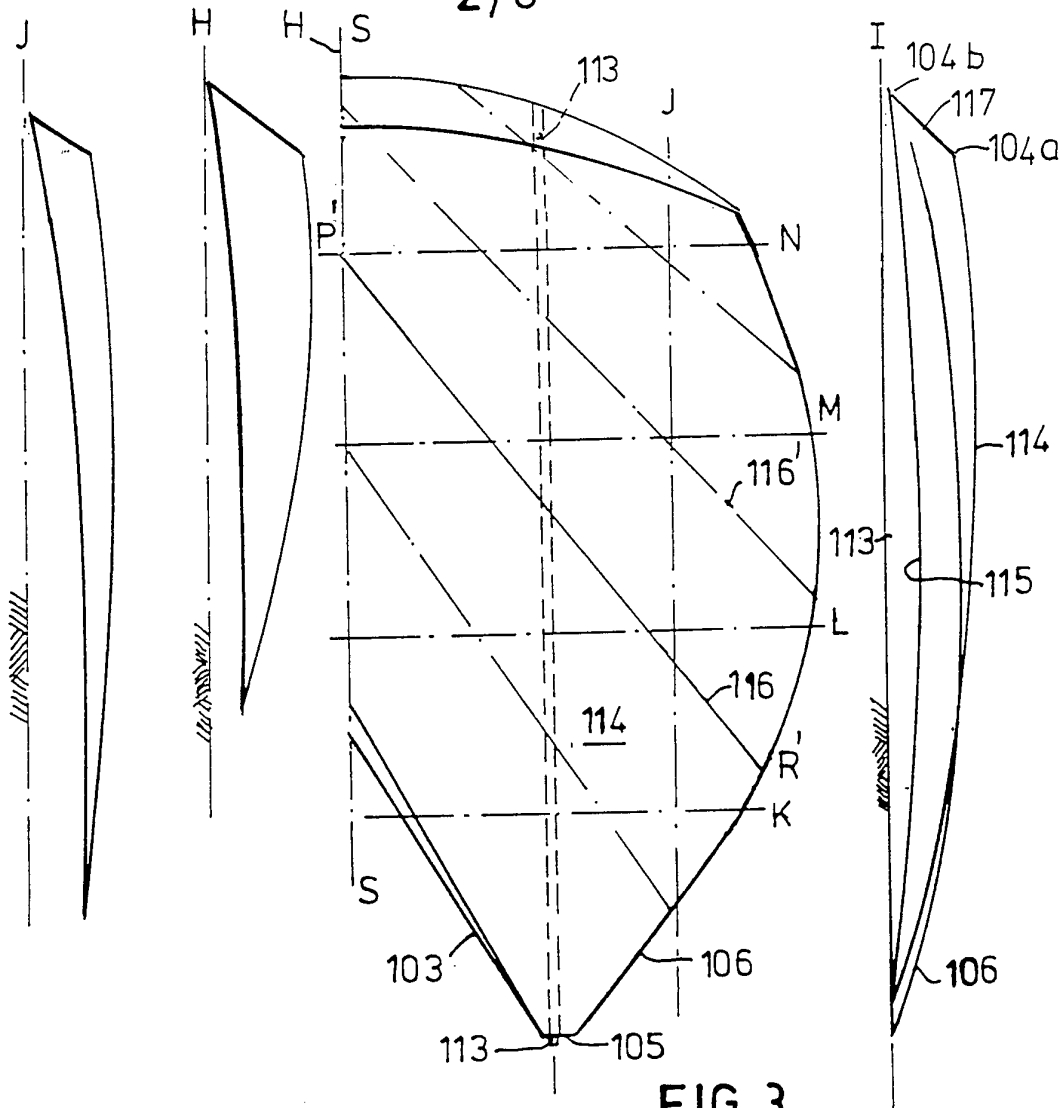

FIG. 3

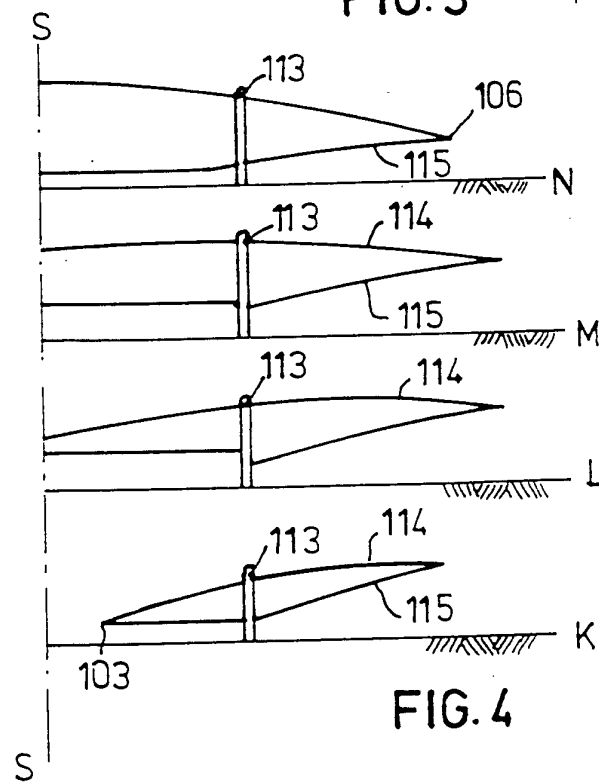

FIG. 4

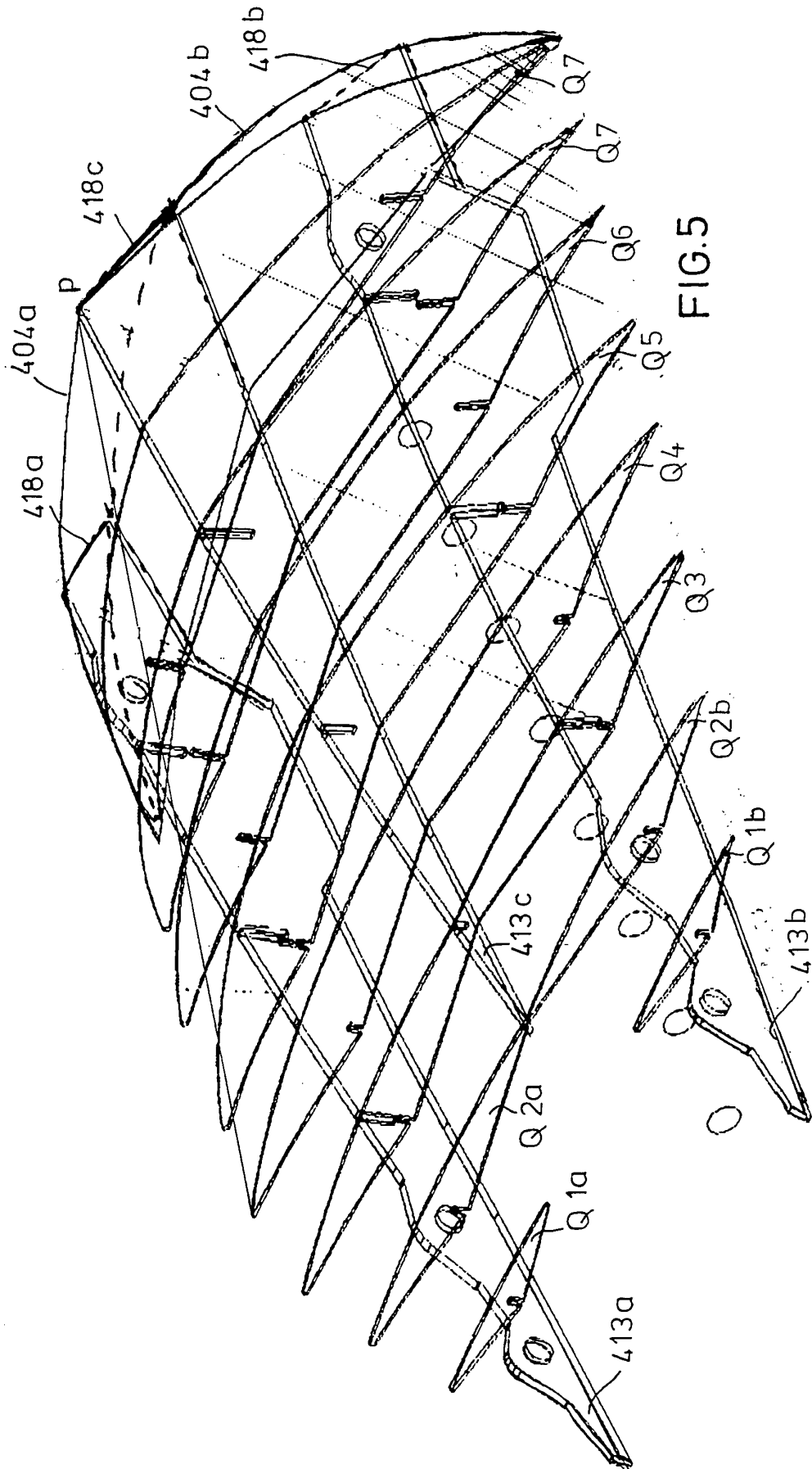
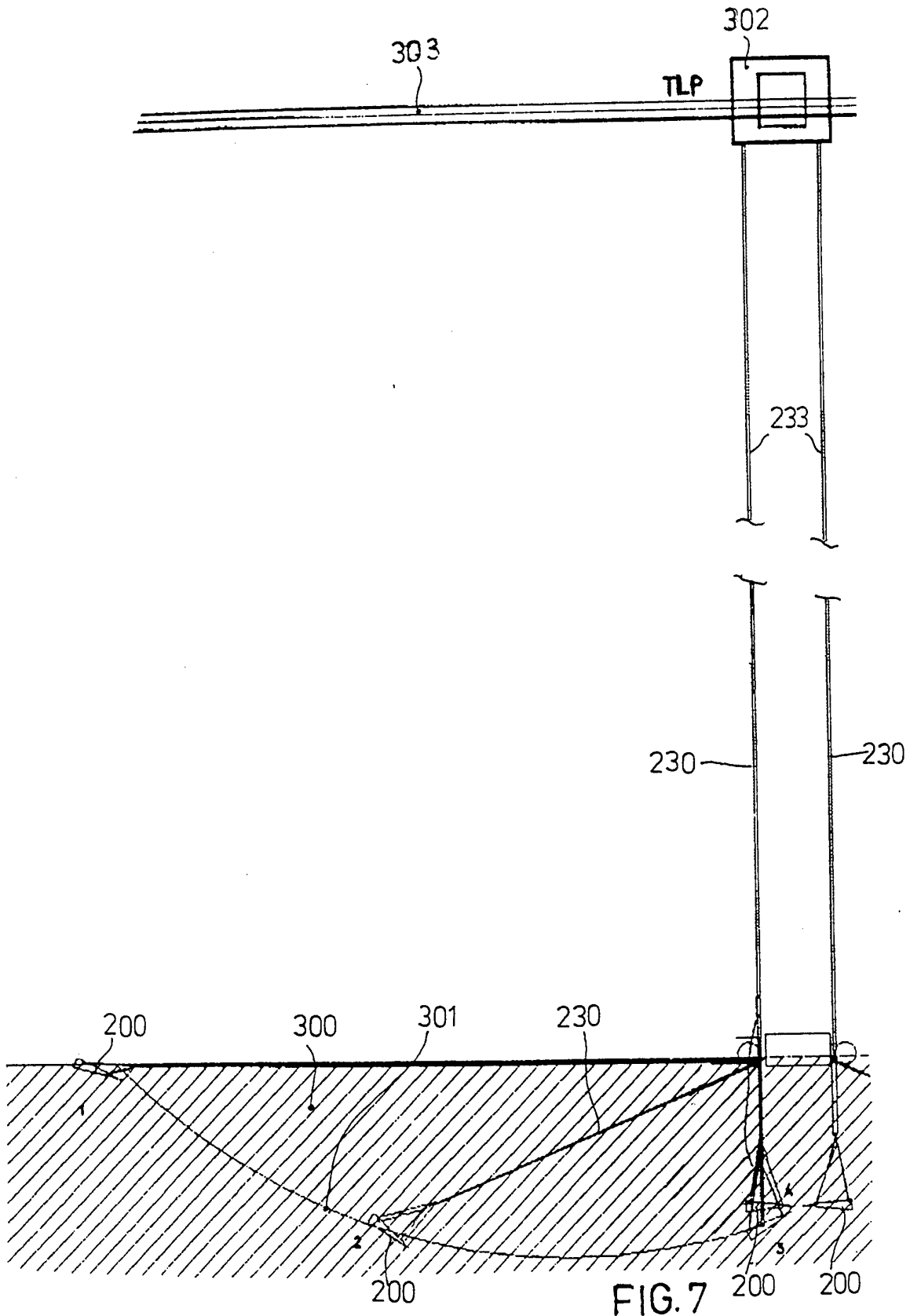

FIG.5



5/6



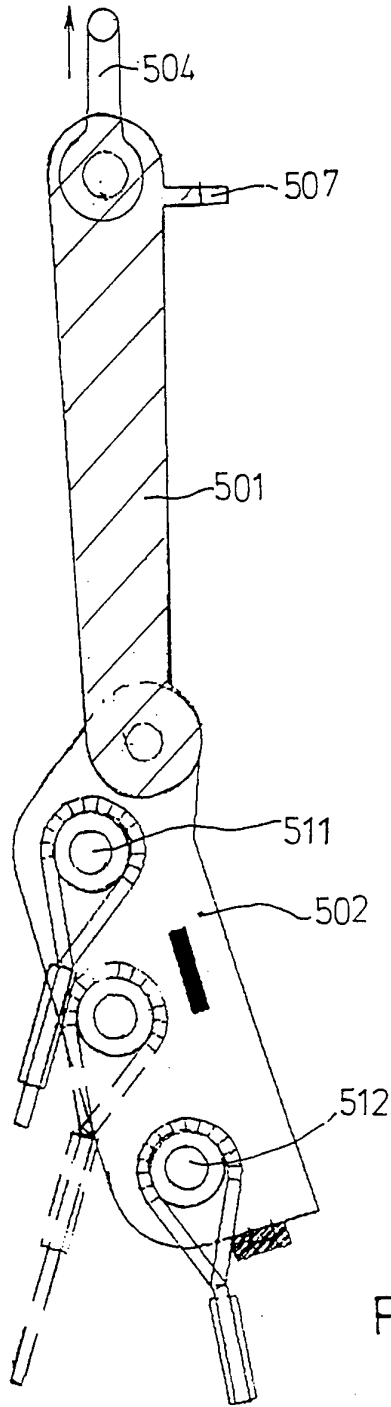

FIG. 9B

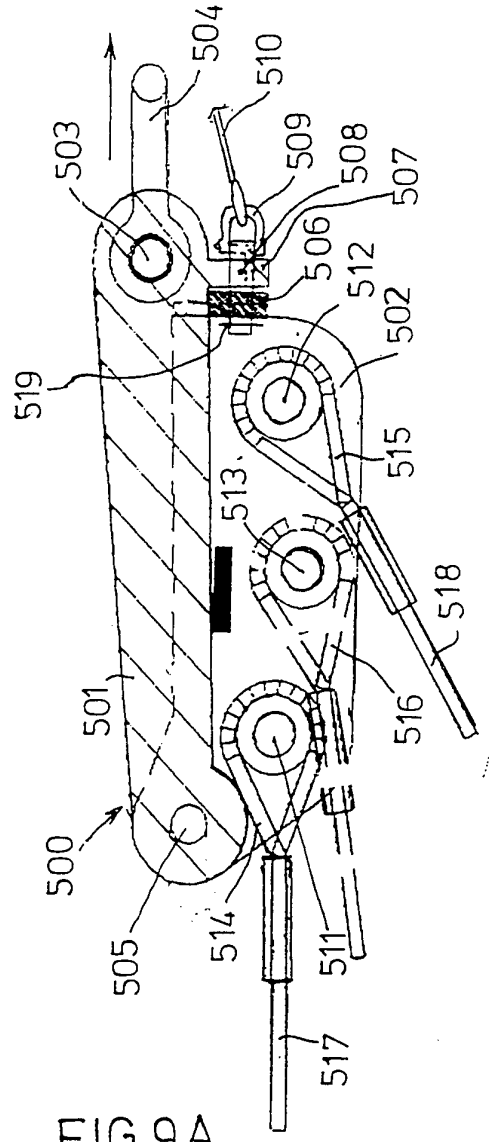

FIG. 9A