



US 20080255616A1

(19) **United States**
(12) **Patent Application Publication**
Atkinson et al.

(10) **Pub. No.: US 2008/0255616 A1**
(43) **Pub. Date: Oct. 16, 2008**

(54) **DEVICES AND METHODS FOR THE TREATMENT OF SPINAL DISORDERS**

No. 10/093,990, filed on Mar. 7, 2002, now Pat. No. 6,835,205, which is a continuation of application No. 09/542,972, filed on Apr. 4, 2000, now Pat. No. 6,402,750.

(75) Inventors: **Robert E. Atkinson**, Stillwater, MN (US); **Peter T. Keith**, St. Paul, MN (US)

Correspondence Address:
OBLON, SPIVAK, MCCLELLAND MAIER & NEUSTADT, P.C.
1940 DUKE STREET
ALEXANDRIA, VA 22314 (US)

Publication Classification

(51) **Int. Cl.**
A61B 17/70 (2006.01)
A61F 2/44 (2006.01)
(52) **U.S. Cl.** **606/246**; 623/17.11; 606/254

(73) Assignee: **ANULEX TECHNOLOGIES, INC.**, MINNETONKA, MN (US)

(57) **ABSTRACT**

(21) Appl. No.: **11/753,649**
(22) Filed: **May 25, 2007**

Devices and methods for treating a damaged intervertebral disc to reduce or eliminate associated back pain. Dynamic bias devices and reinforcement devices are disclosed, which may be used individually or in combination, to eliminate nerve impingement associated with the damaged disc, and/or to reinforce the damaged disc, while permitting relative movement of the vertebrae adjacent the damaged disc.

Related U.S. Application Data

(63) Continuation of application No. 10/967,042, filed on Oct. 15, 2004, which is a continuation of application

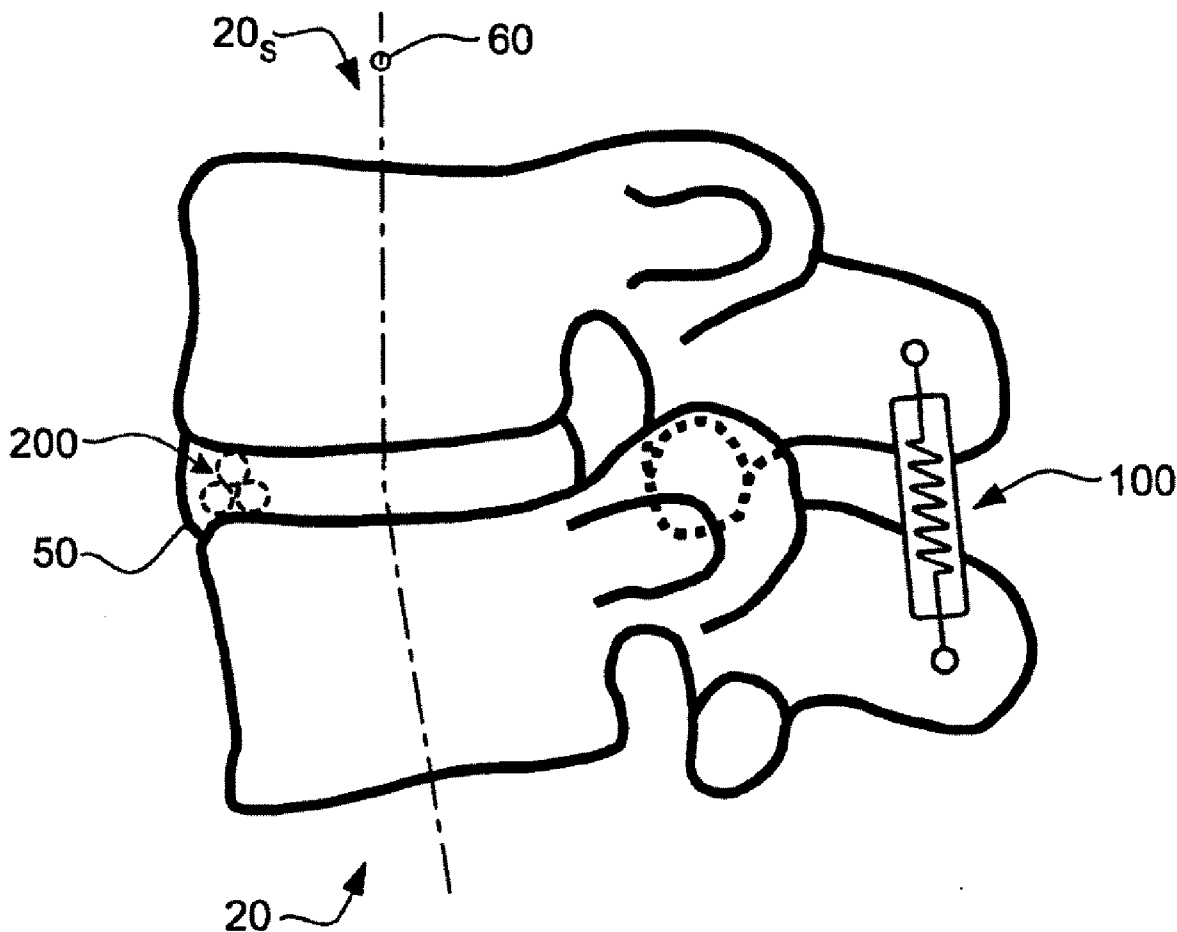

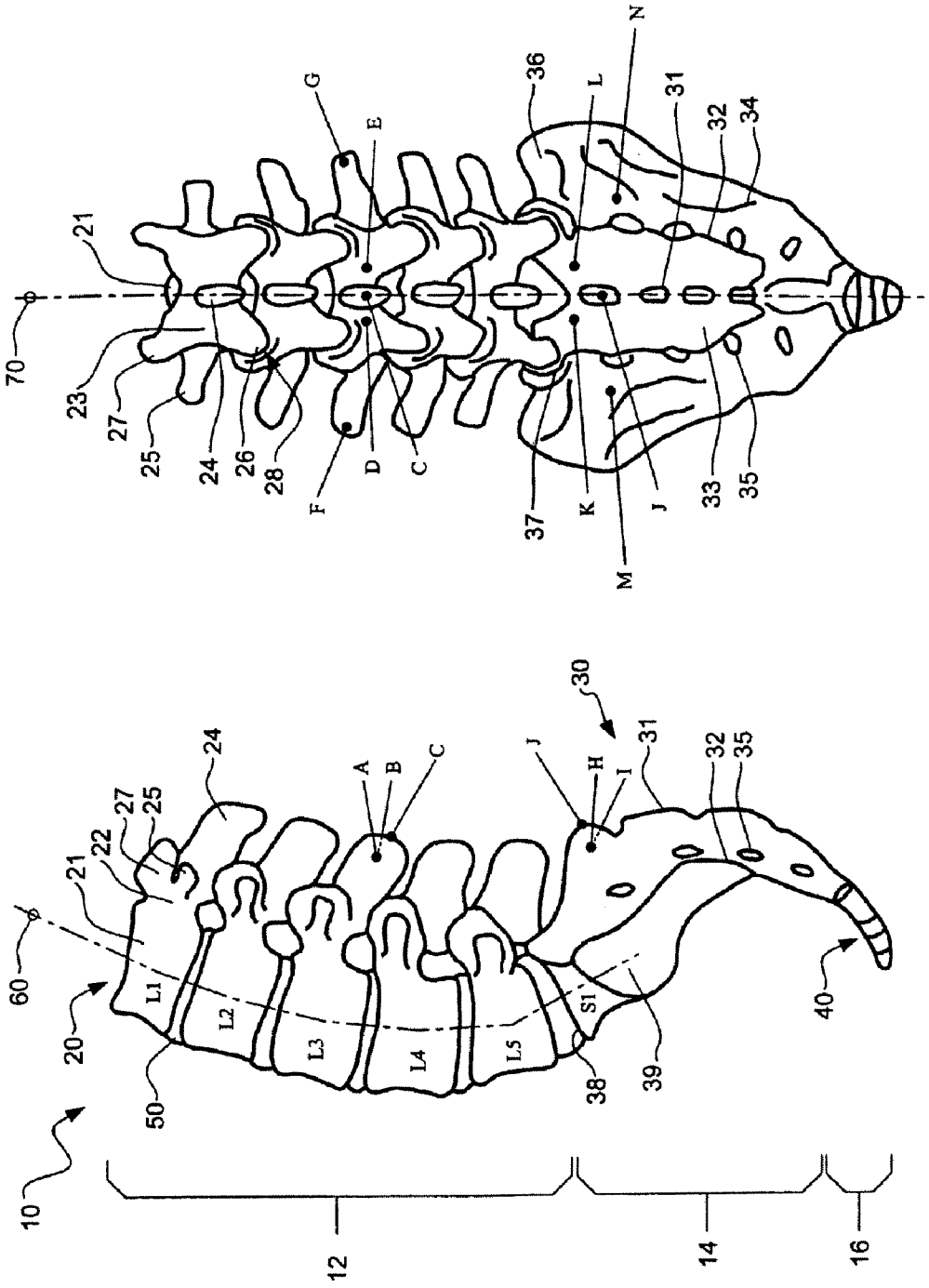
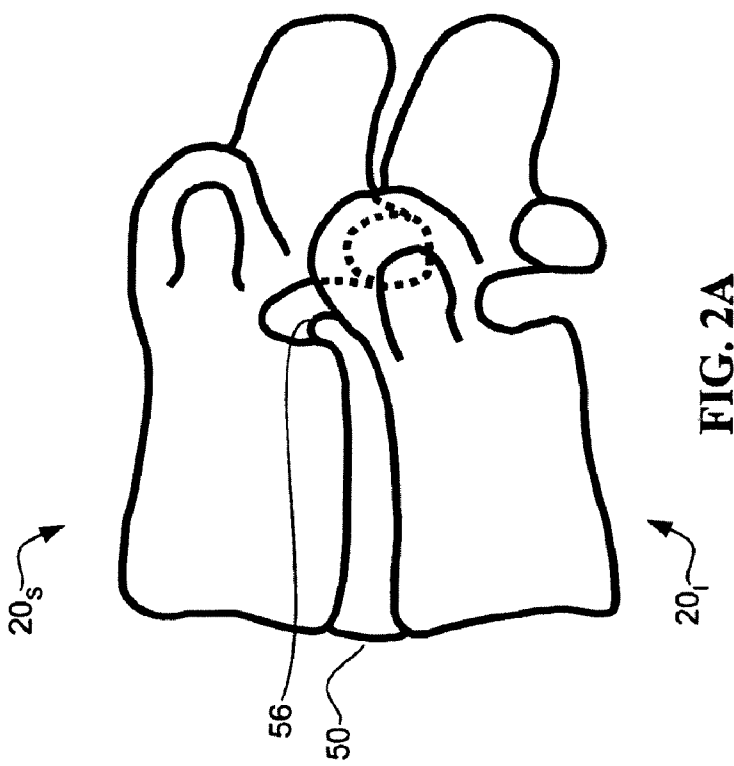
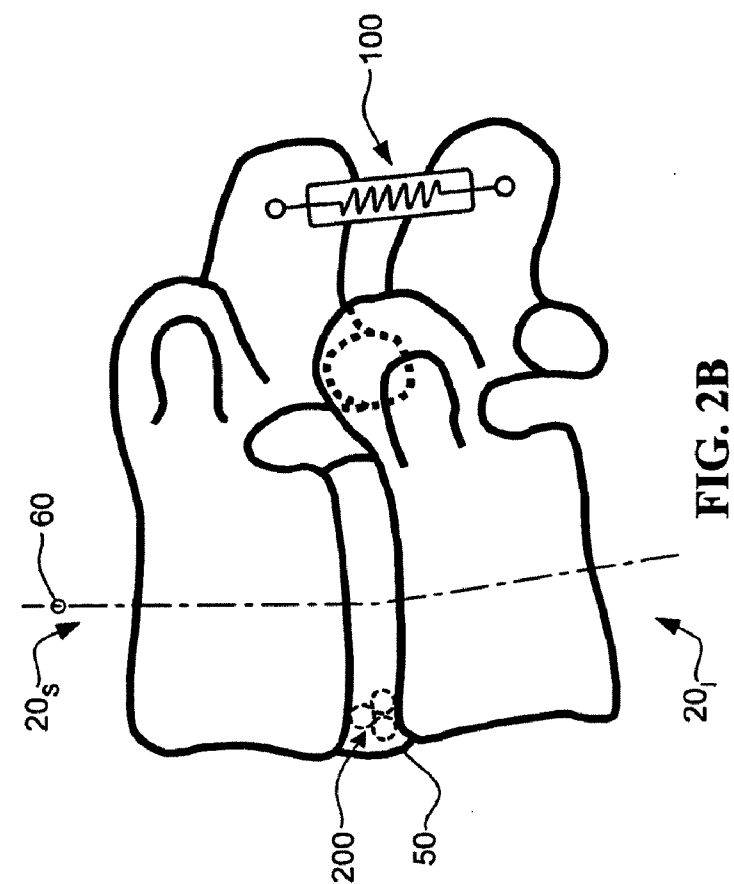

FIG. 1B

FIG. 1A



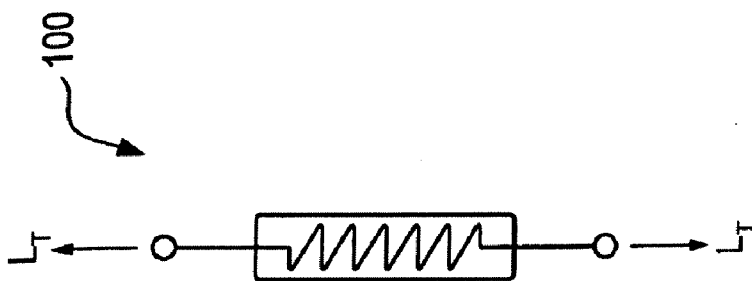

FIG. 3A

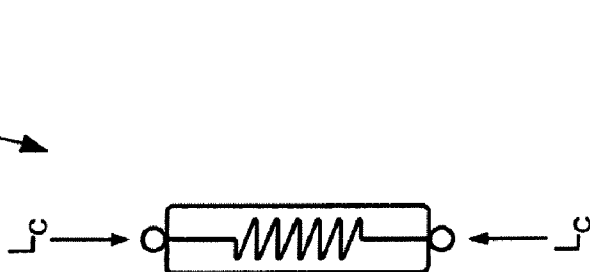

FIG. 3B

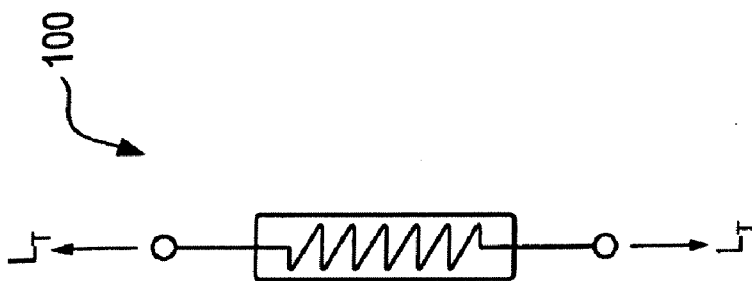

FIG. 3C

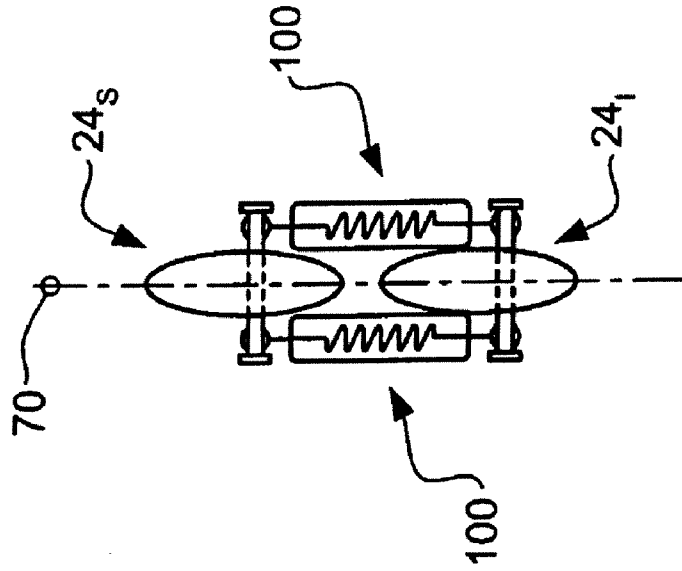

FIG. 4B

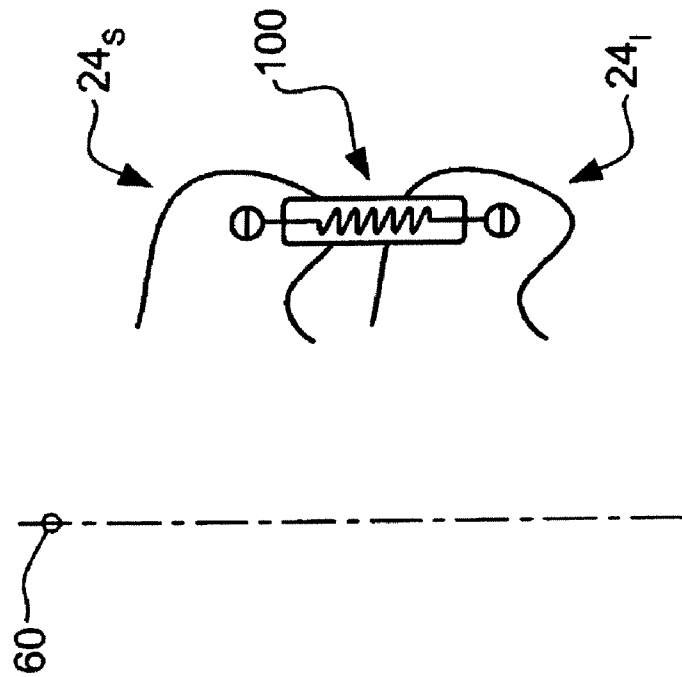

FIG. 4A

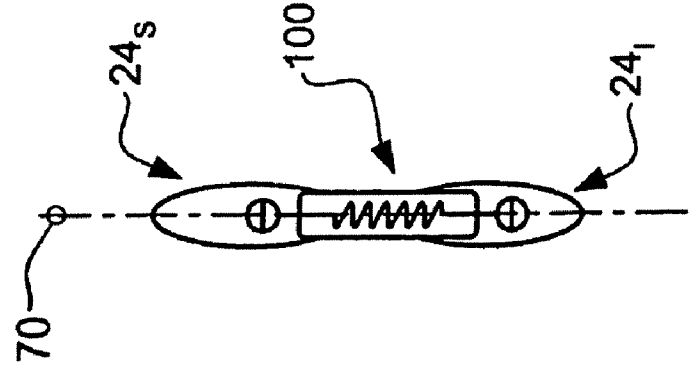

FIG. 5B

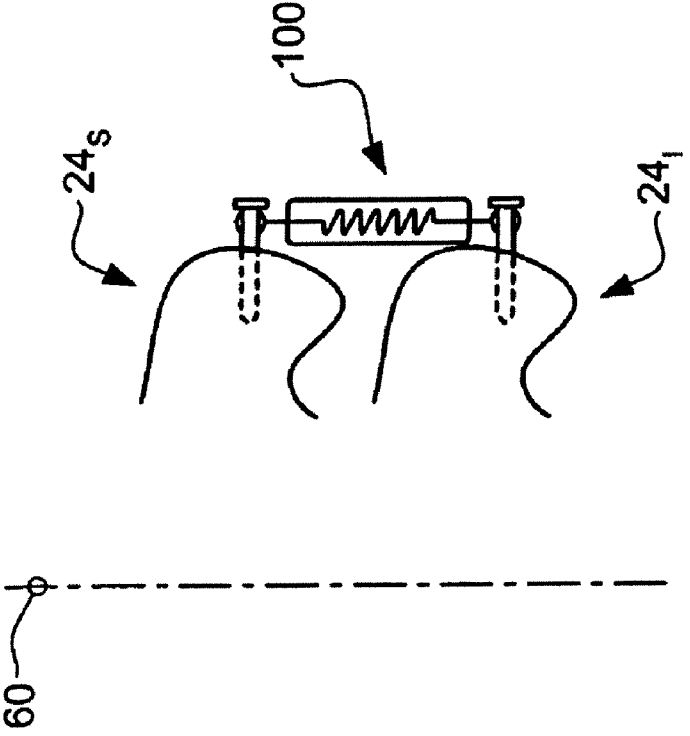

FIG. 5A

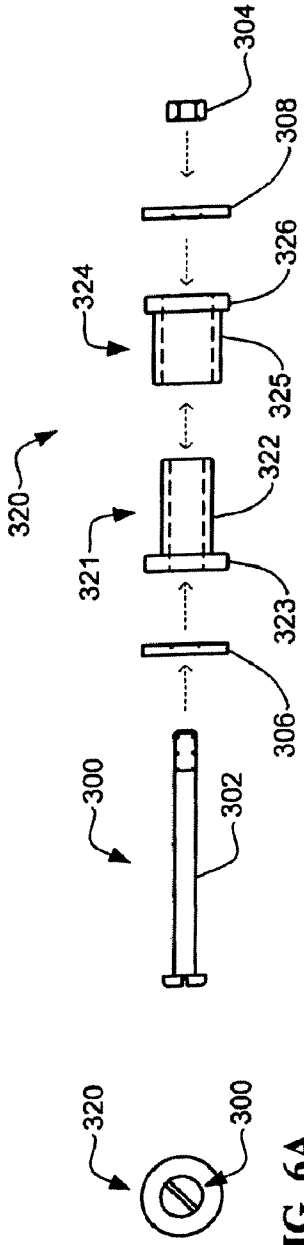

FIG. 6A

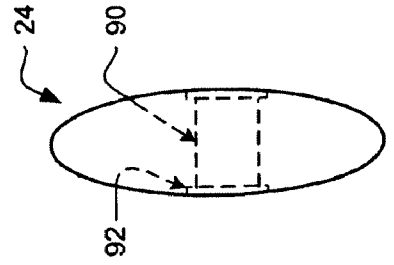

FIG. 6B

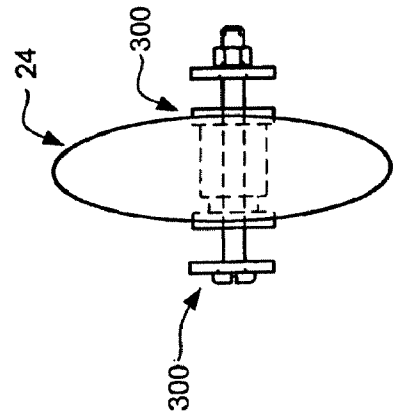

FIG. 6C



FIG. 6D

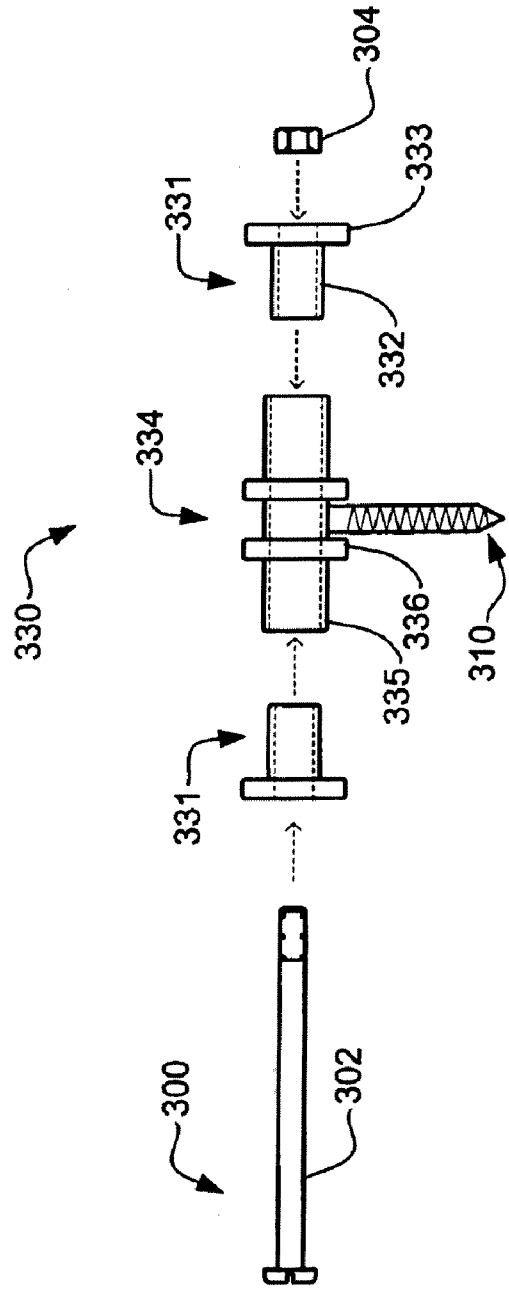

FIG. 7A

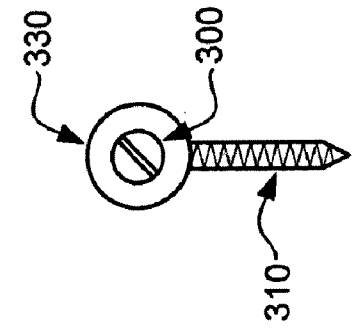

FIG. 7B

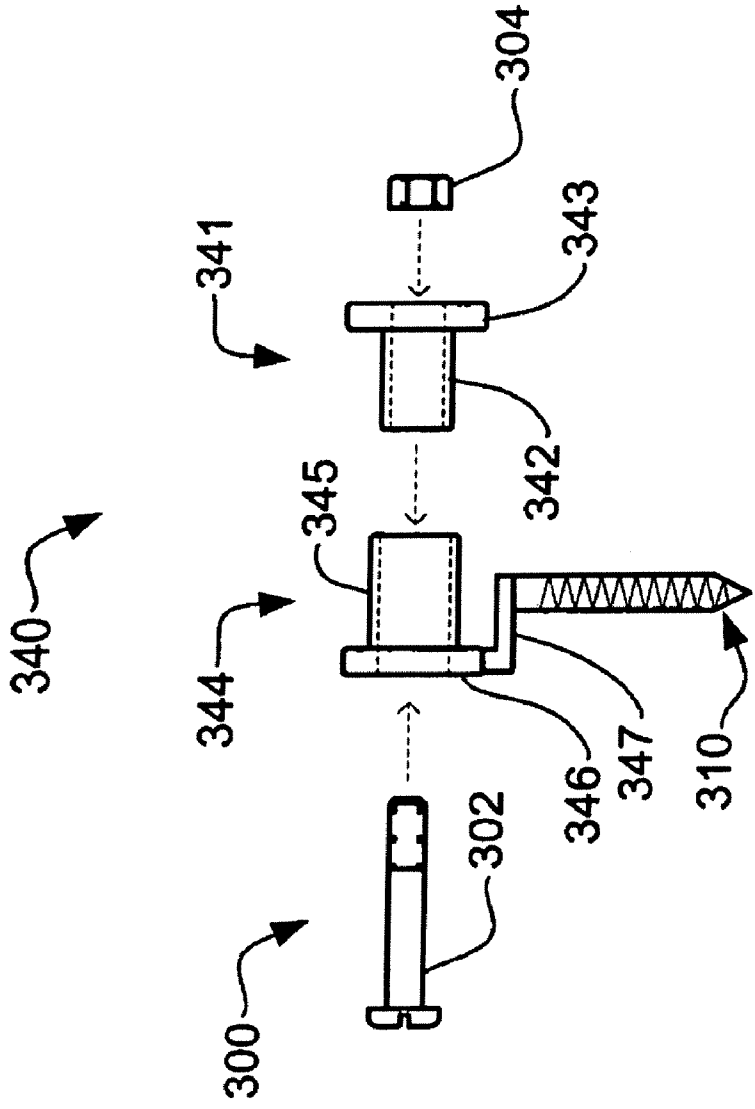

FIG. 8A

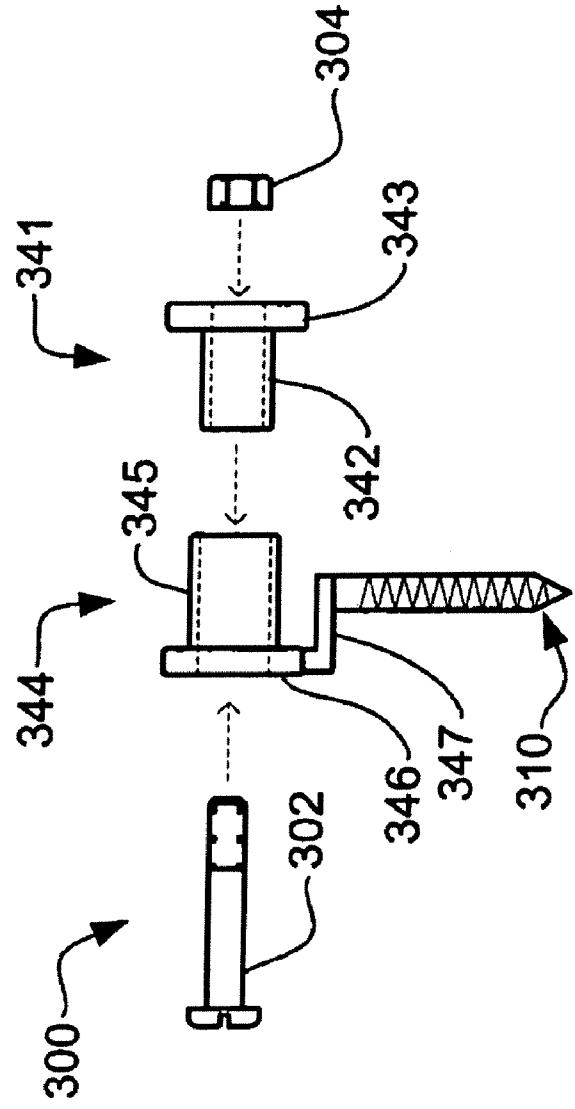

FIG. 8B

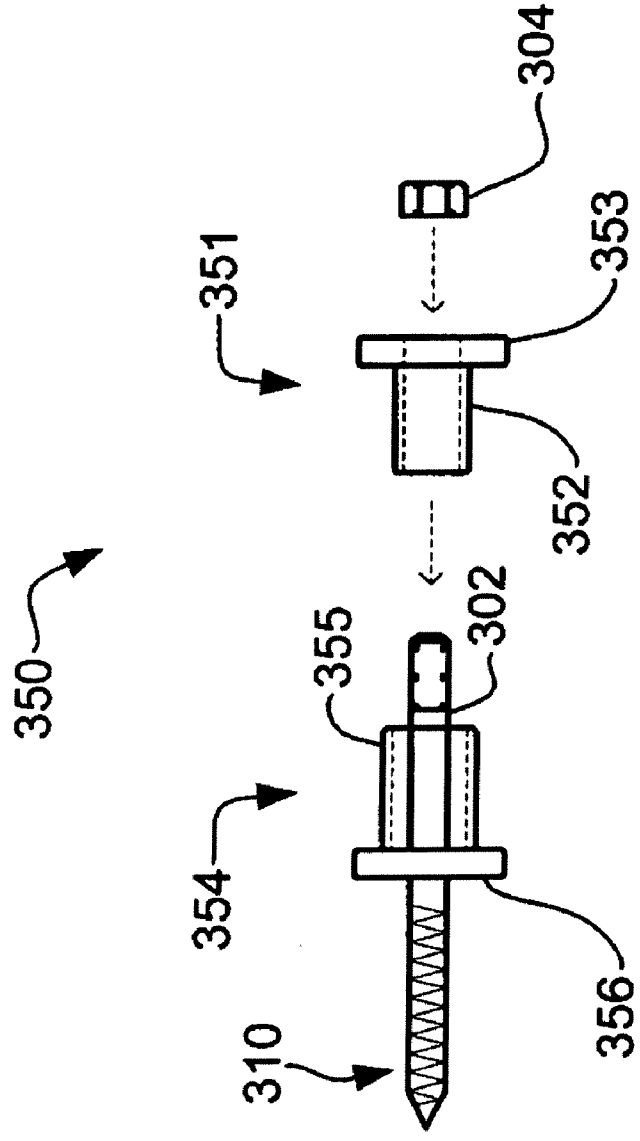

FIG. 9B

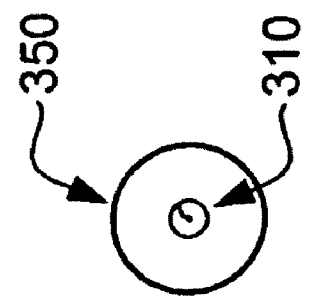

FIG. 9A

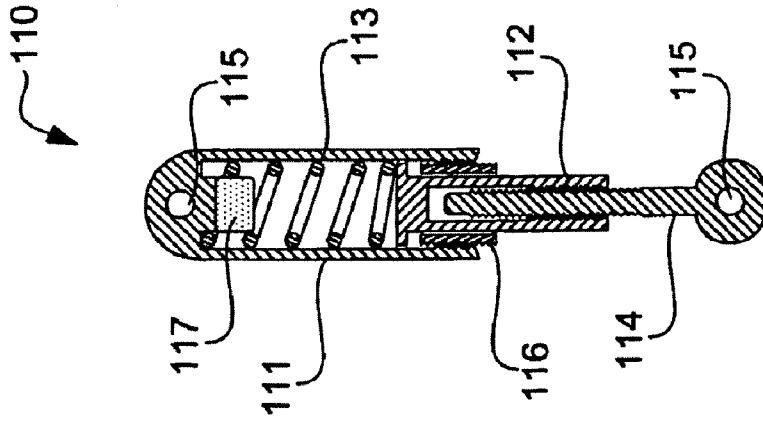

FIG. 10A

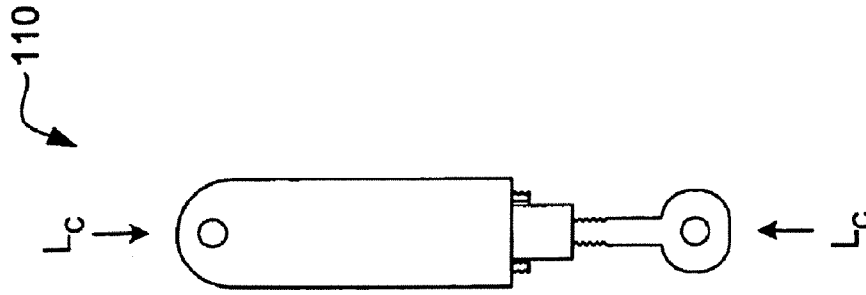

FIG. 10B

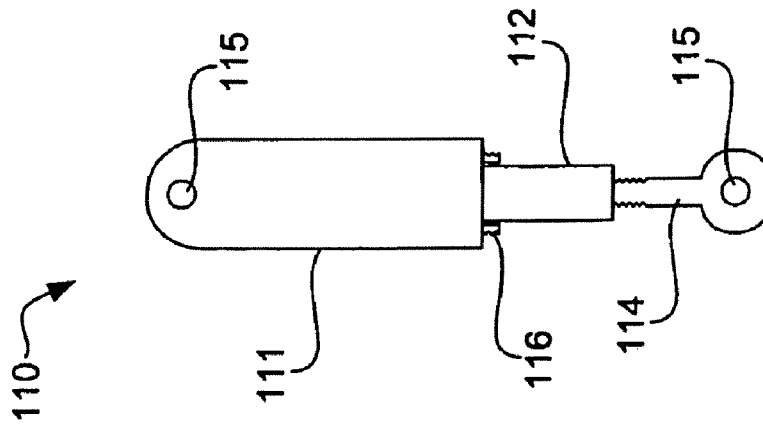

FIG. 10C

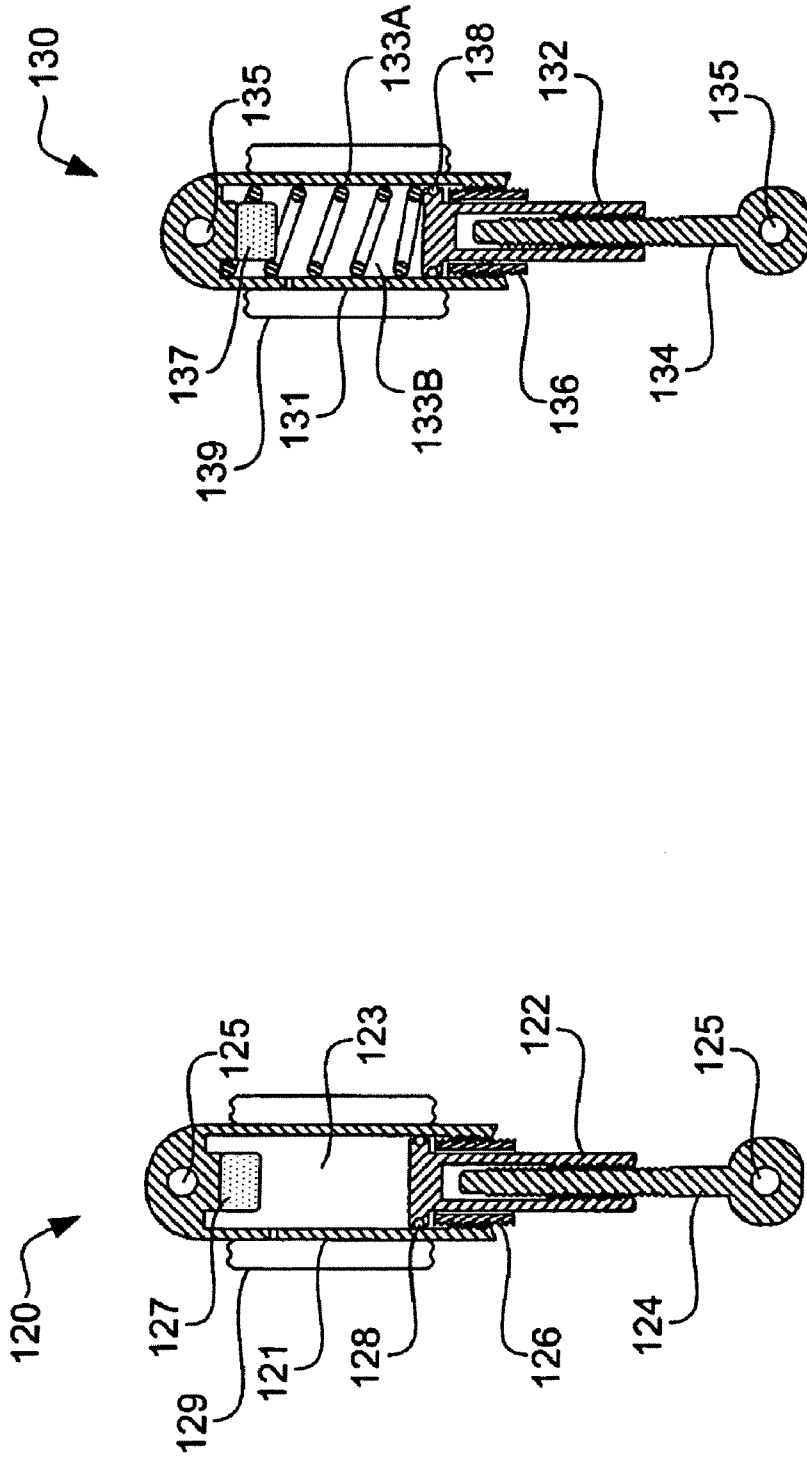

FIG. 11B

FIG. 11A

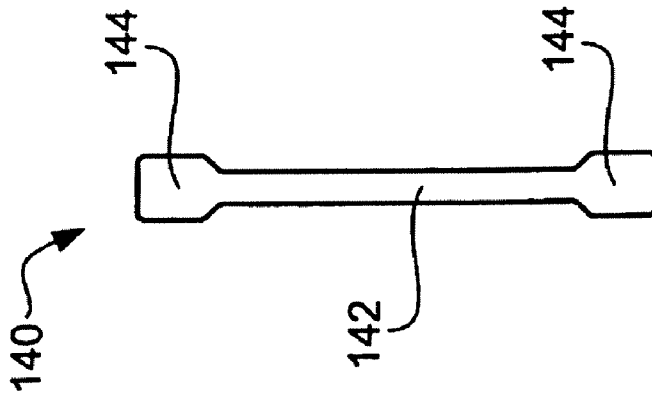

FIG. 12A

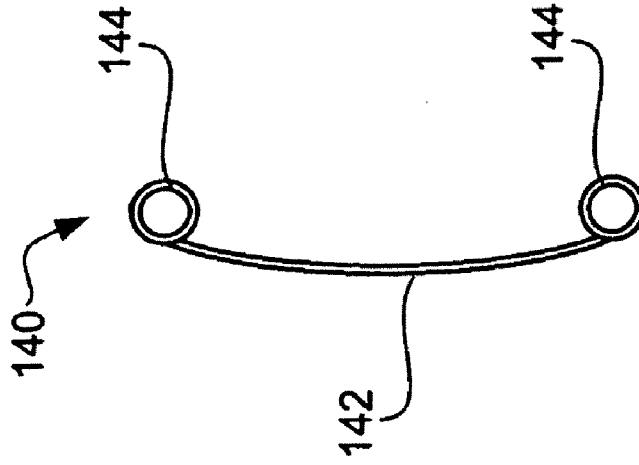

FIG. 12B

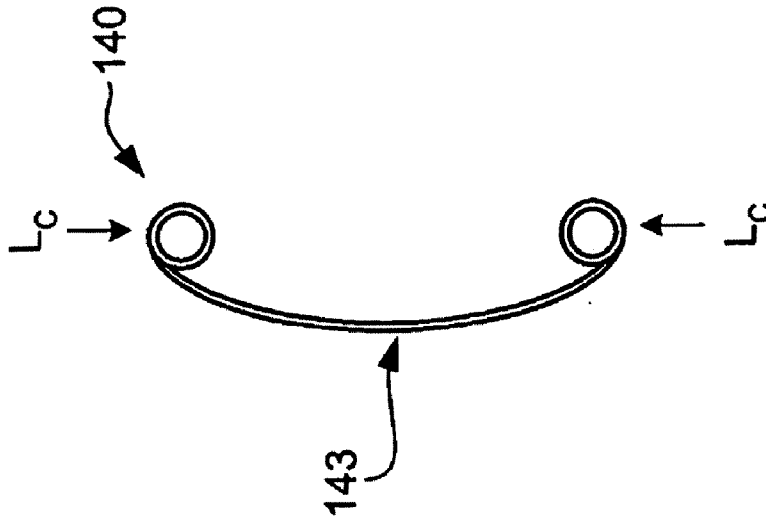

FIG. 12C

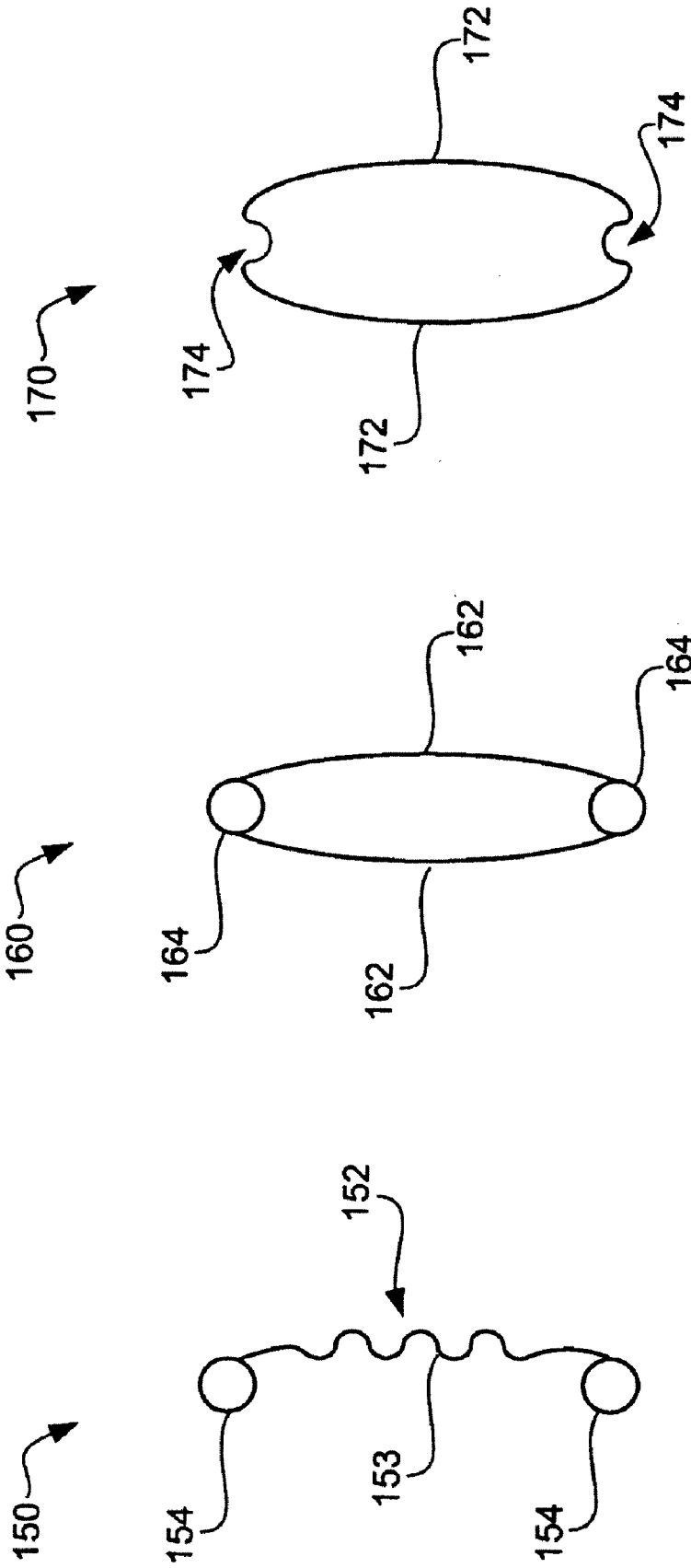

FIG. 13A

FIG. 13B

FIG. 13C

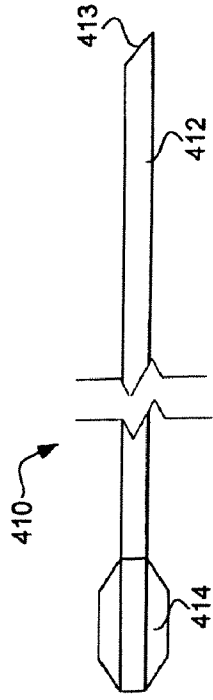

FIG. 14A

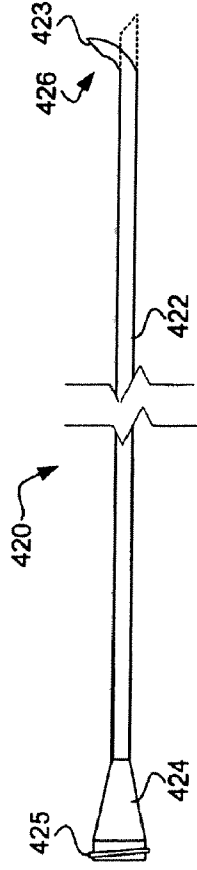

FIG. 14B

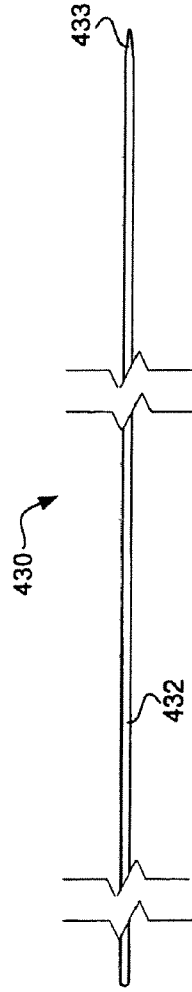

FIG. 14C

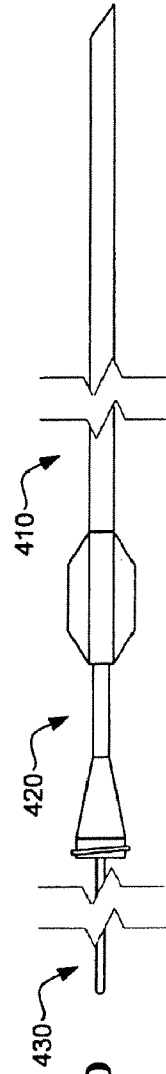

FIG. 14D

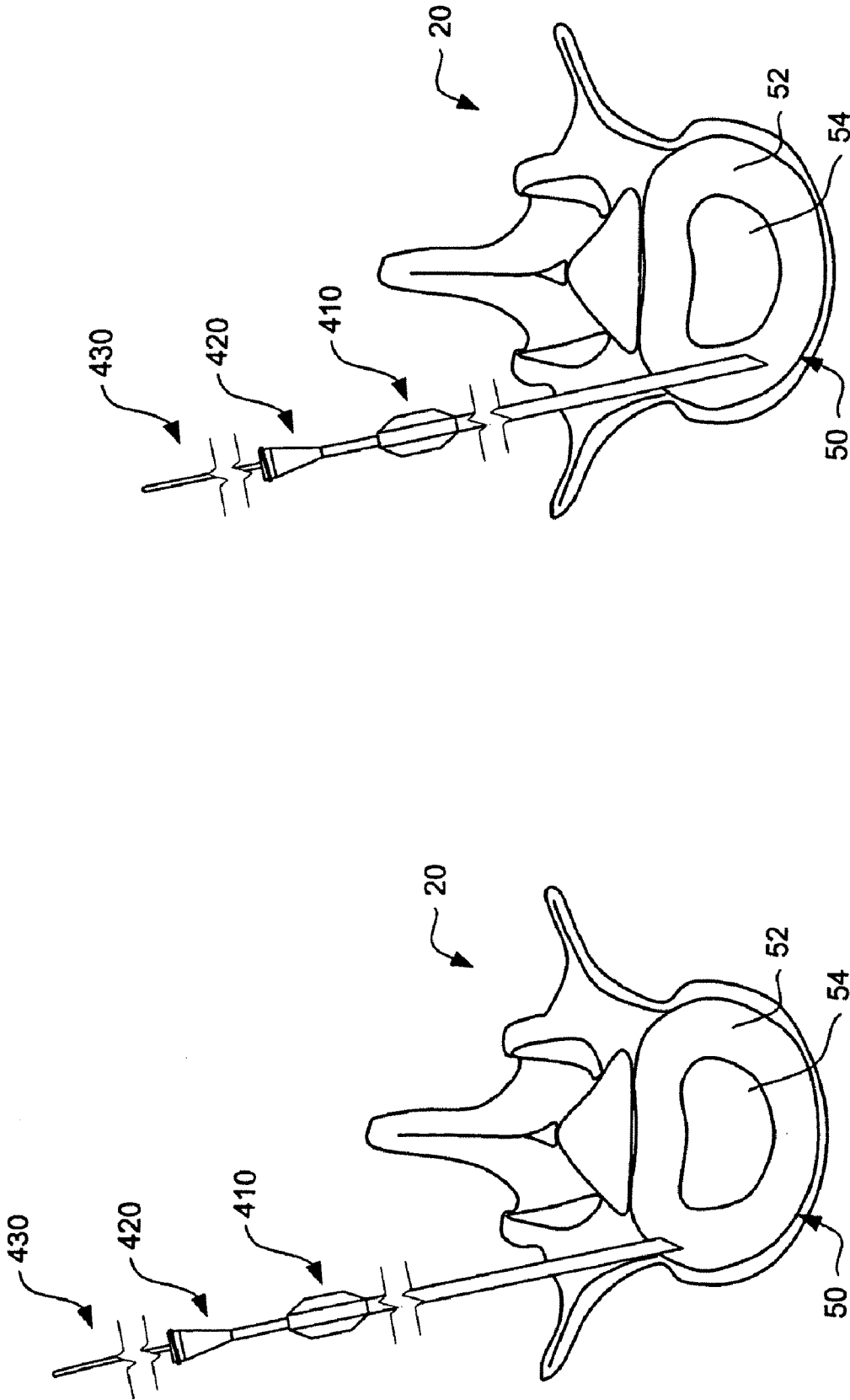

FIG. 15B

FIG. 15A

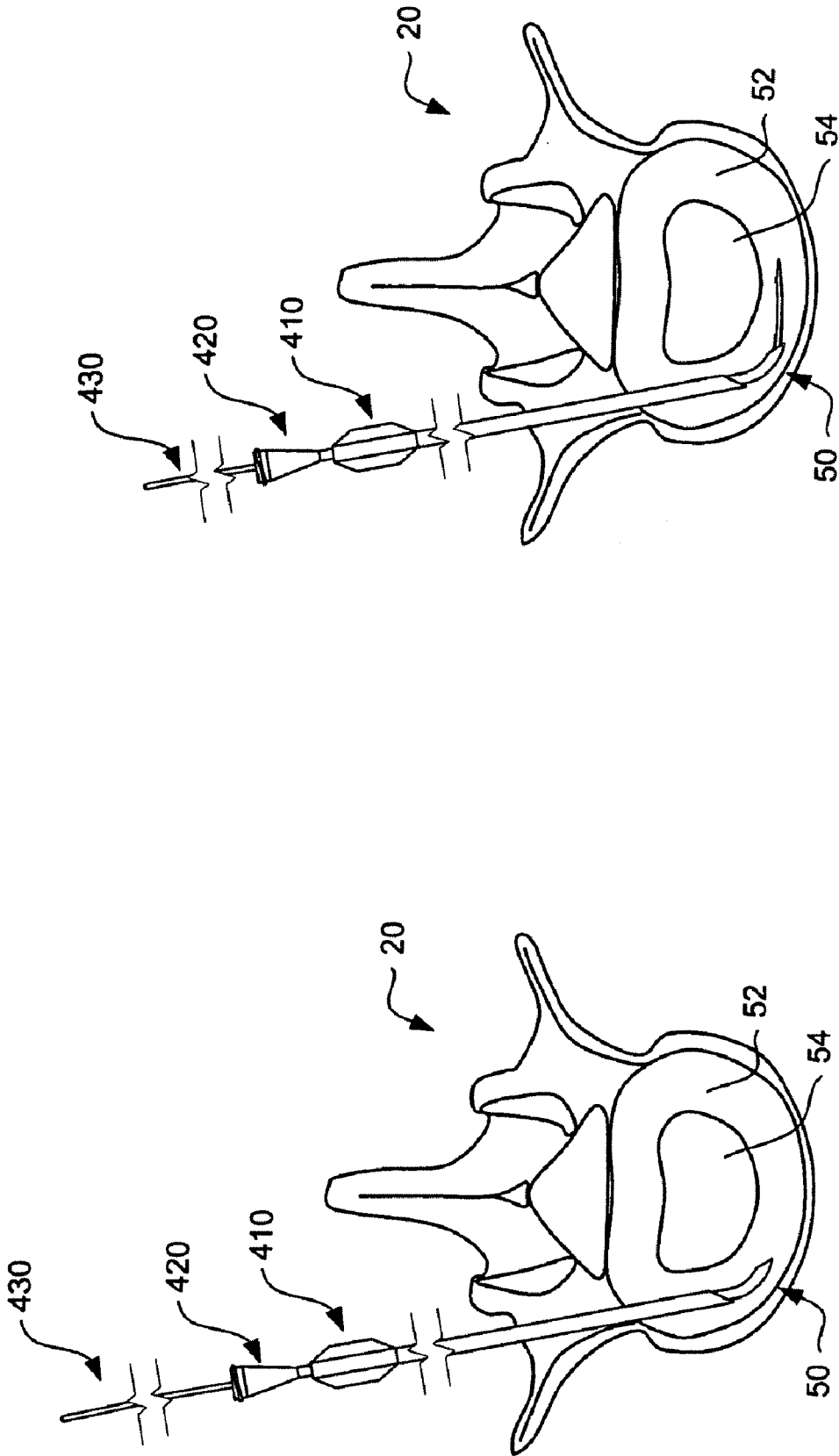

FIG. 15D

FIG. 15C

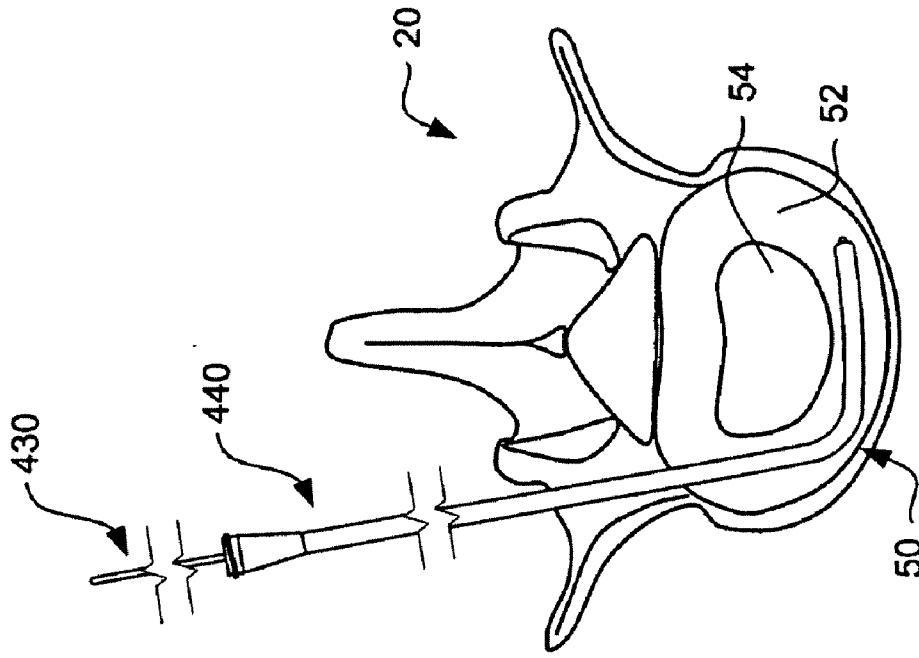

FIG. 15E

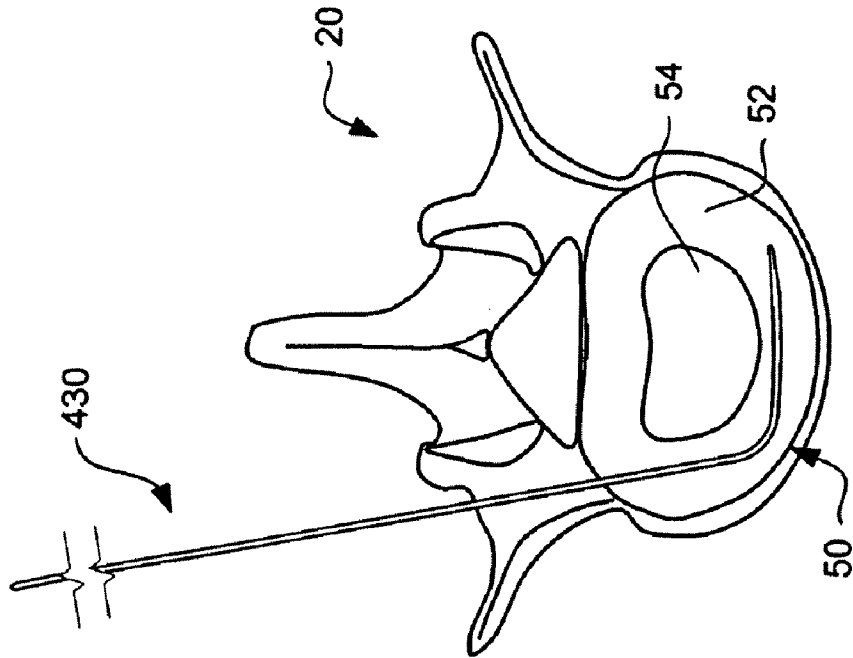

FIG. 15F

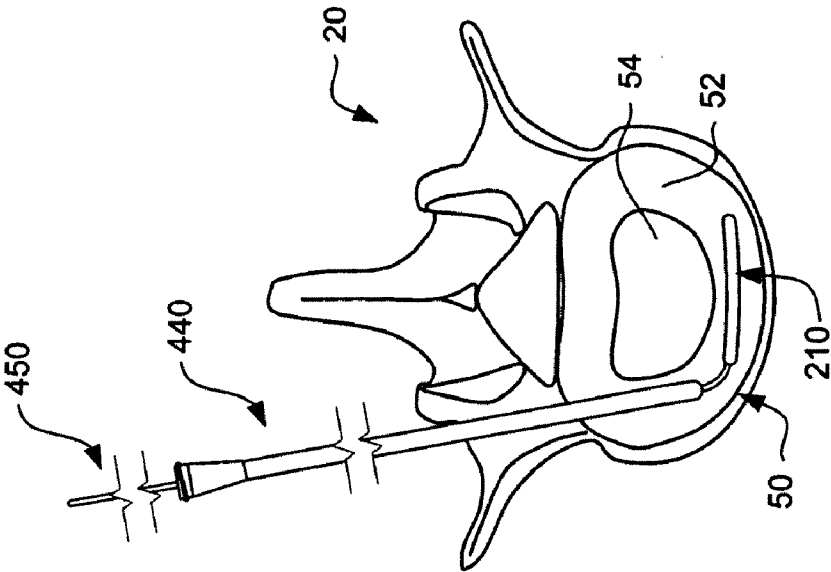

FIG. 15H

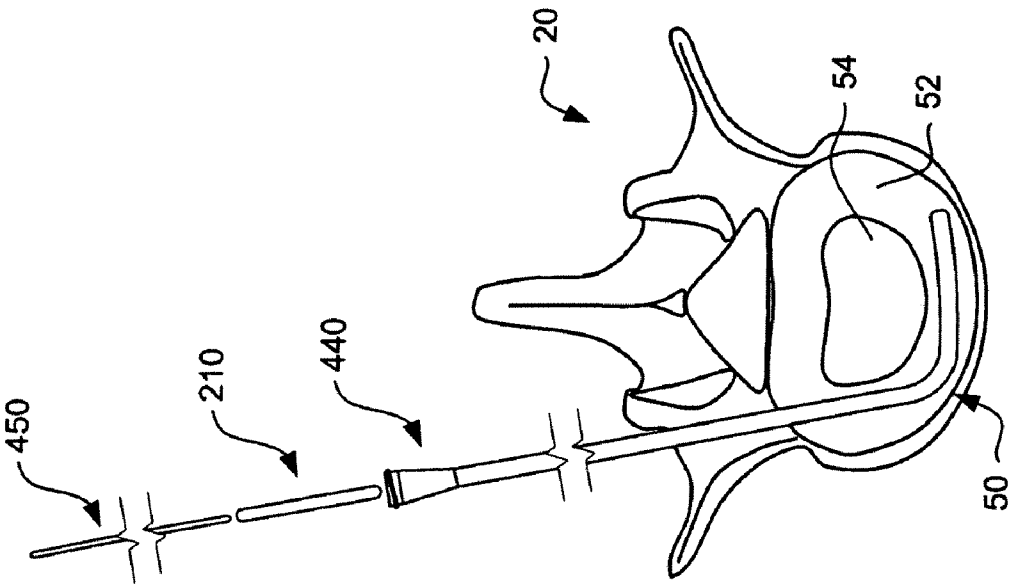

FIG. 15G

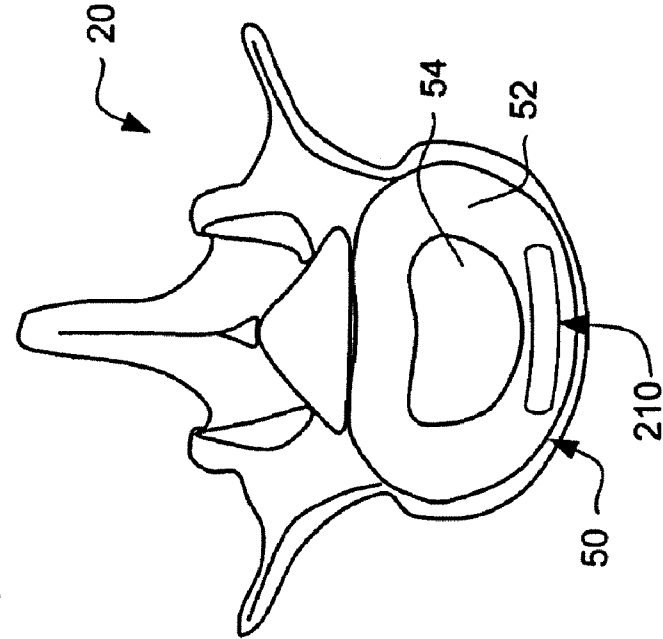

FIG. 15J

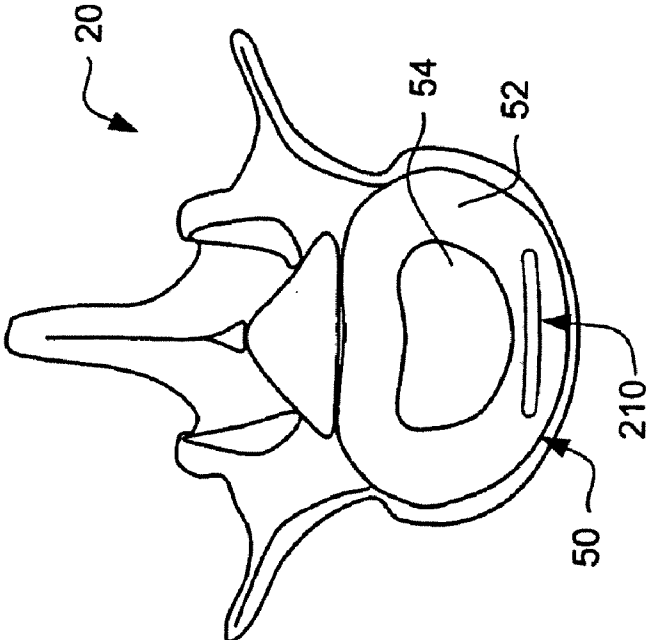

FIG. 15I

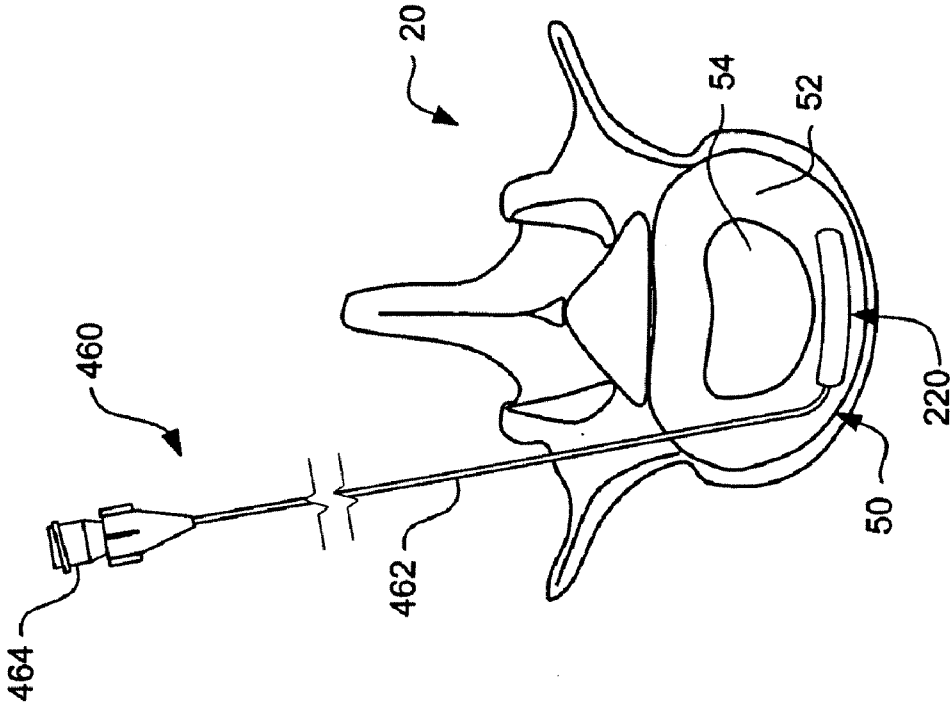

FIG. 15L

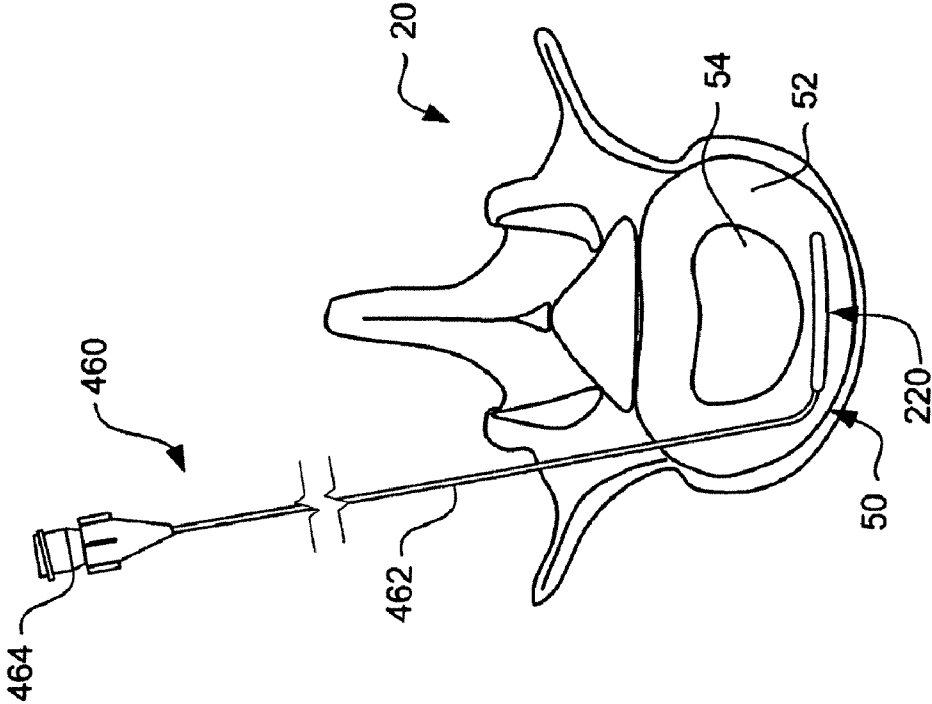

FIG. 15K

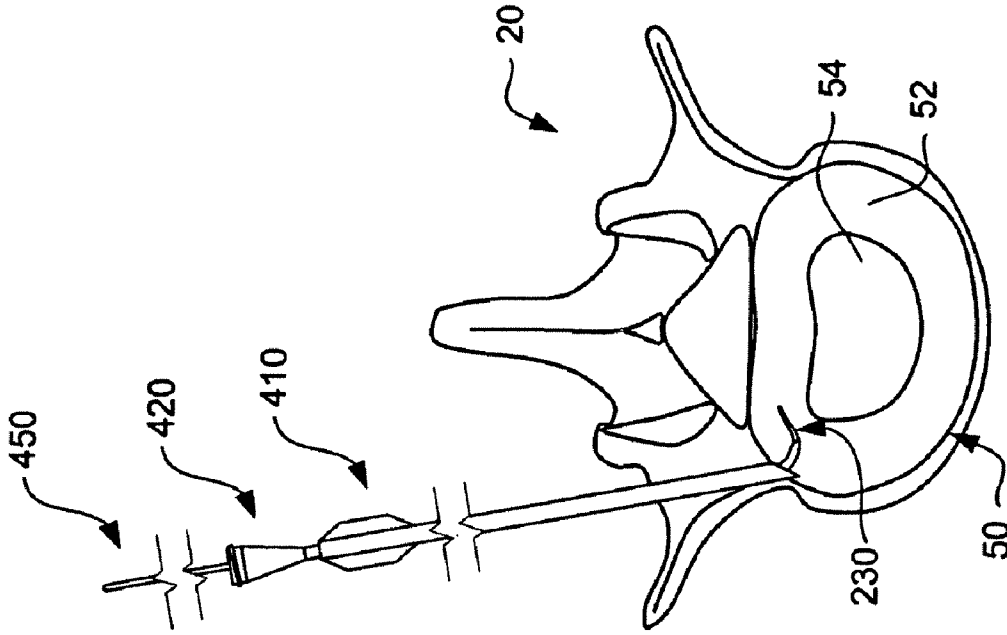

FIG. 15N

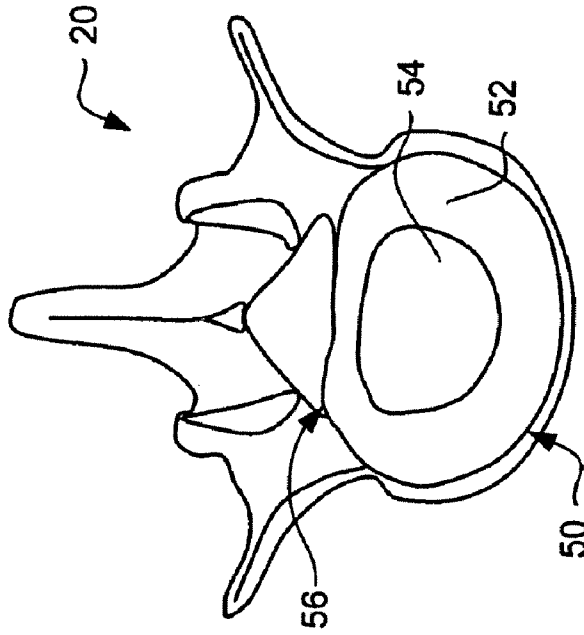

FIG. 15M

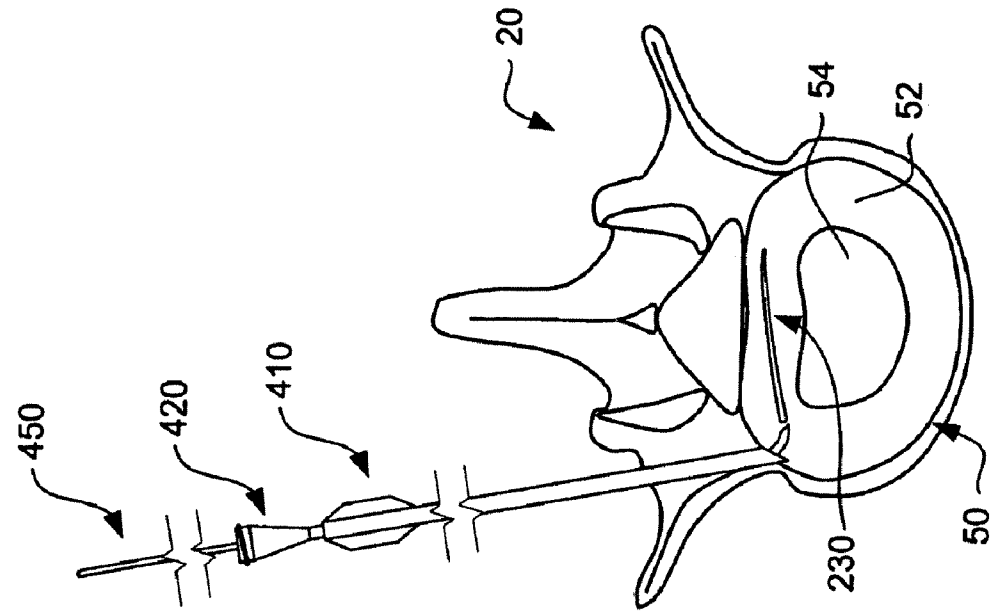

FIG. 150

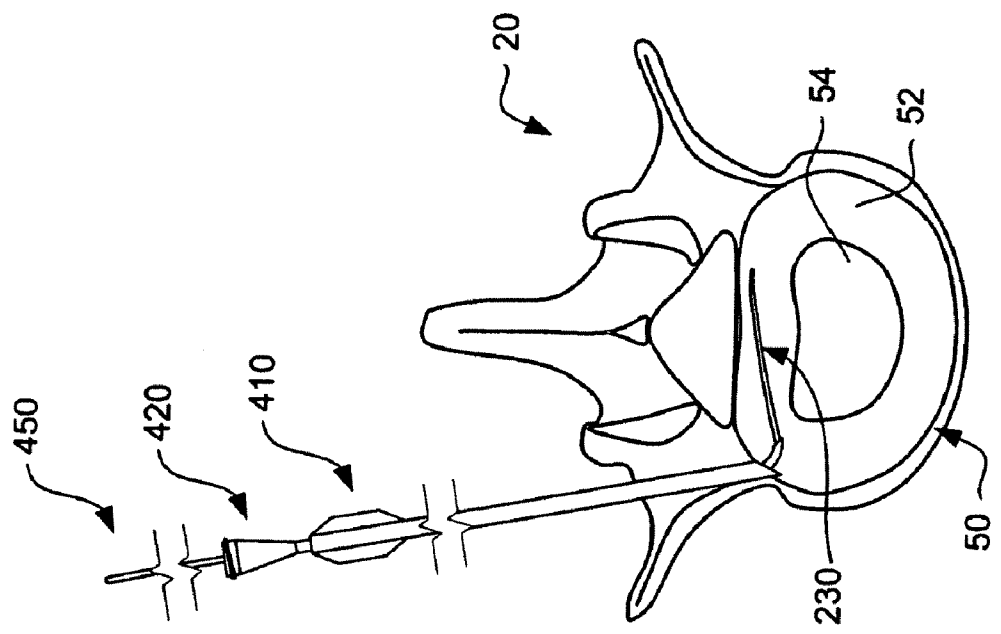

FIG. 15P

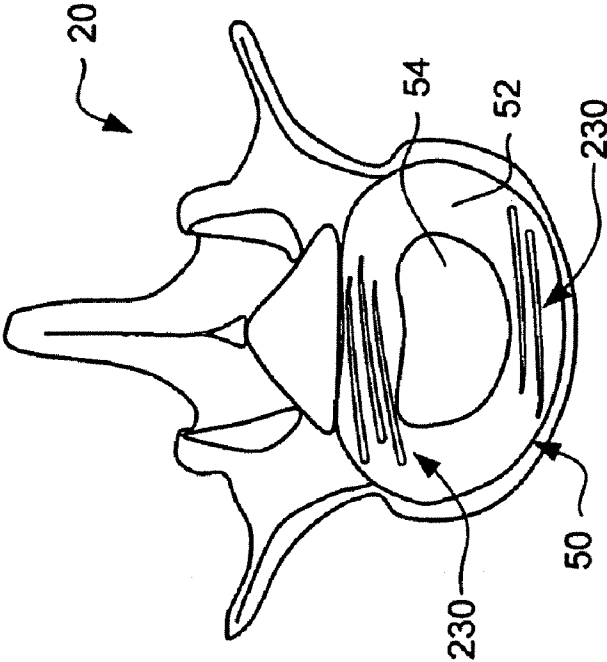

FIG. 15R

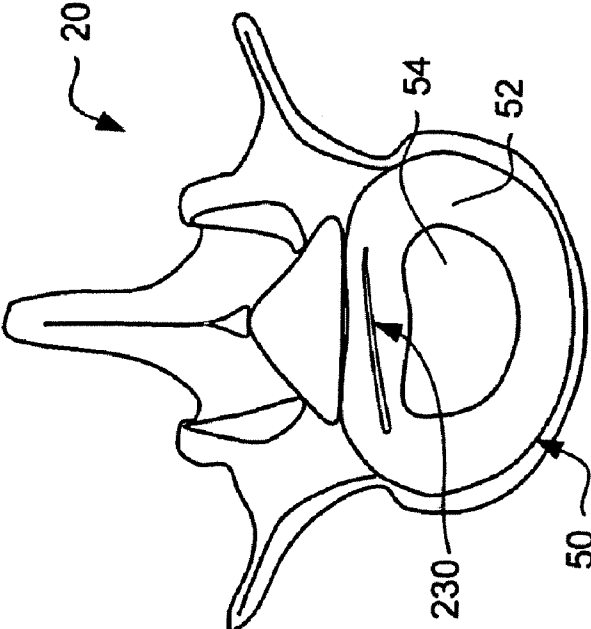

FIG. 15Q

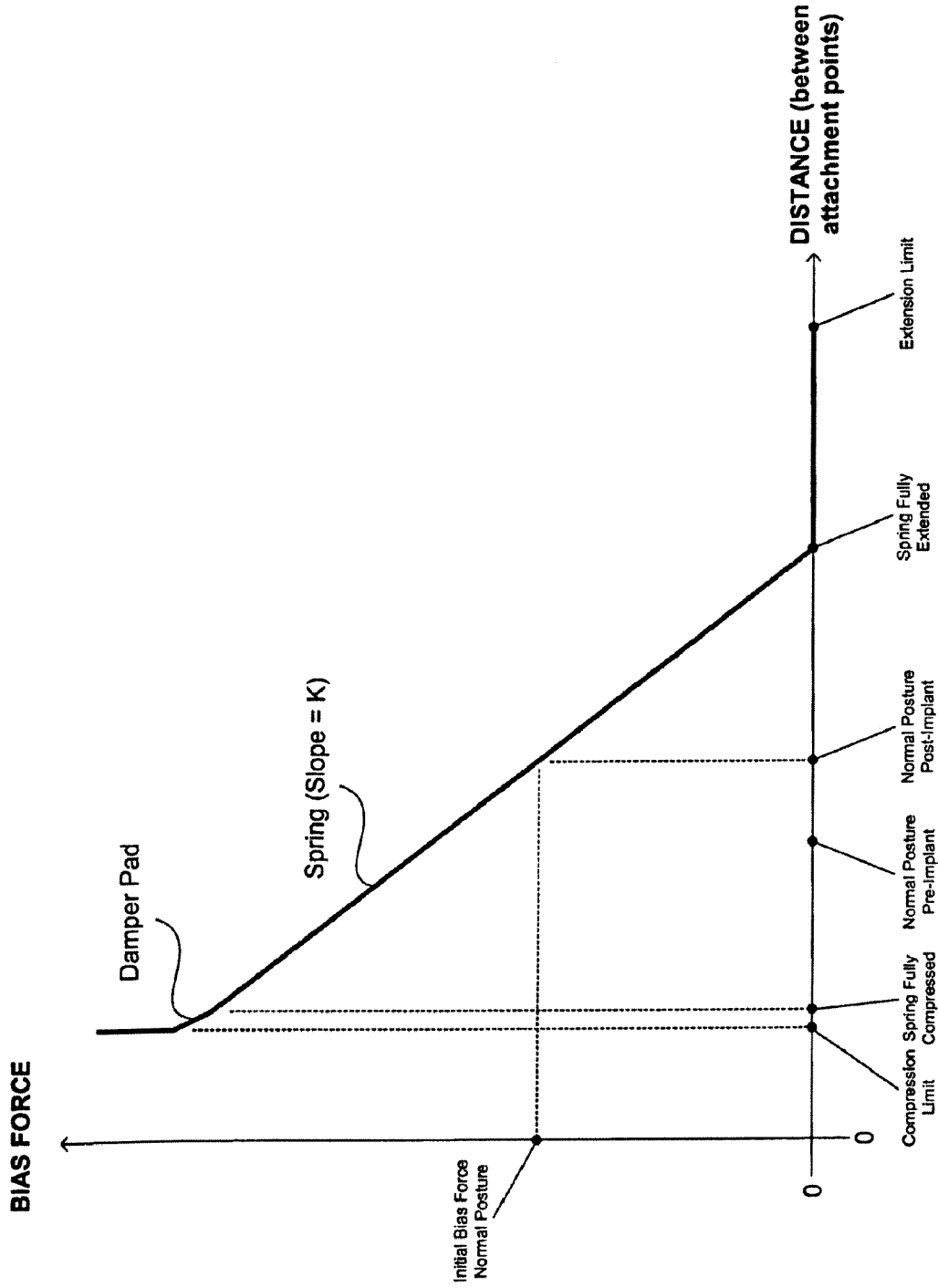

FIG. 16

DEVICES AND METHODS FOR THE TREATMENT OF SPINAL DISORDERS

CROSS REFERENCE TO RELATED APPLICATIONS

[0001] The present application is a continuation of U.S. application Ser. No. 10/967,042, filed Oct. 15, 2004; which is a continuation of U.S. application Ser. No. 10/093,990 filed on Mar. 7, 2002, now U.S. Pat. No. 6,835,205; which is a continuation of U.S. application Ser. No. 09/542,972, filed on Apr. 4, 2000, now U.S. Pat. No. 6,402,750. and claims the benefit of U.S. Provisional Application No. 60/368,108 filed Mar. 26, 2002 entitled DEVICES AND METHODS FOR THE TREATMENT OF SPINAL DISORDERS, the entire disclosure of which is incorporated herein by reference.

FIELD OF THE INVENTION

[0002] The present invention generally relates to spinal implants. Specifically, the present invention relates to implantable devices and methods for the treatment of spinal disorders associated with the intervertebral disc.

BACKGROUND OF THE INVENTION

[0003] Back pain is one of the most common and often debilitating conditions affecting millions of people in all walks of life. Today, it is estimated that over ten million people in the United States alone suffer from persistent back pain. Approximately half of those suffering from persistent back pain are afflicted with chronic disabling pain, which seriously compromises a person's quality of life and is the second most common cause of worker absenteeism. Further, the cost of treating chronic back pain is very high, even though the majority of sufferers do not receive treatment due to health risks, limited treatment options and inadequate therapeutic results. Thus, chronic back pain has a significantly adverse effect on a person's quality of life, on industrial productivity, and on health care expenditures.

[0004] Some forms of back pain are not chronic and may be simply treated by rest, posture adjustments and painkillers. For example, some forms of lower back pain (LBP) are very common and may be caused by unusual exertion or injury. Unusual exertion such as heavy lifting or strenuous exercise may result in back strain such as a pulled muscle, sprained muscle, sprained ligament, muscle spasm, or a combination thereof. An injury caused by falling down or a blow to the back may cause bruising. These forms of back pain are typically non-chronic and may be self-treated and cured in a few days or weeks.

[0005] Other types of non-chronic back pain may be treated by improvements in physical condition, posture and/or work conditions. For example, being pregnant, obese or otherwise significantly overweight may cause LBP. A mattress that does not provide adequate support may cause back pain in the morning. Working in an environment lacking good ergonomic design may also cause back pain. In these instances, the back pain may be cured by eliminating the culprit cause. Whether it is excess body weight, a bad mattress, or a bad office chair, these forms of back pain are readily treated.

[0006] However, some forms of back pain are chronic and are the result of spinal disorders which are not readily treated. Such spinal disorders may cause severe back pain, the origin of which may or may not be certain. A prevalent clinical theory is that pain arises from physical impingement of the

nerve roots or the spinal cord. Such nerve impingement may have of a number of different causes, but generally results from either a disc protrusion or from narrowing of the intervertebral foramina which surround the nerve roots. Another clinical theory is that damage to the disc, either from injury, degradation or otherwise, causes physical impingement of the disc nerves, which are primarily disposed about the periphery of the annulus, but may grow into fissures of a damaged disc.

[0007] Disc protrusions may be caused by a physical injury to the disc or by natural degradation of the disc such as by degenerative disc disease (DDD). Physical injury may cause damage to the annulus fibrosus which allows a portion of the disc, such as the nucleus pulposus, to protrude from the normal disc space. DDD may cause the entire disc to degenerate to such a degree that the annulus fibrosus bulges outward, delaminates or otherwise separates such that a portion of the disc protrudes from the normal disc space. In either case, the disc protrusion may impinge on a spinal nerve root causing severe pain. Impingement on the nerve root may also be caused by conditions unrelated to the disc such as by a spinal tumor or spinal stenosis (abnormal bone growth), but disc protrusions are the most common cause. Depending on the cause and nature of the disc protrusion, the condition may be referred to as a disc stenosis, a disc bulge, a herniated disc, a slipped disc, a prolapsed disc or, if the protrusion separates from the disc, a sequestered disc.

[0008] Nerve root impingement most often occurs in the lumbar region of the spinal column since the lumbar discs bear significant vertical loads relative to discs in other regions of the spine. In addition, disc protrusions in the lumbar region typically occur posteriorly because the annulus fibrosus is thinner on the posterior side than on the anterior side and because normal posture places more compression on the posterior side. Posterior protrusions are particularly problematic since the nerve roots are posteriorly positioned relative to the intervertebral discs. When a posterior disc protrusion presses against a nerve root, the pain is often severe and radiating, and may be aggravated by such subtle movements as coughing, bending over, or remaining in a sitting position for an extended period of time.

[0009] A common treatment for disc protrusion is discectomy, which is a procedure wherein the protruding portion of the disc is surgically removed. However, discectomy procedures have an inherent risk since the portion of the disc to be removed is immediately adjacent the nerve root and any damage to the nerve root is clearly undesirable. Furthermore, discectomy procedures are not always successful long term because scar tissue may form and/or additional disc material may subsequently protrude from the disc space as the disc deteriorates further. The recurrence of a disc protrusion may necessitate a repeat discectomy procedure, along with its inherent clinical risks and less than perfect long term success rate. Thus, a discectomy procedure, at least as a stand-alone procedure, is clearly not an optimal solution.

[0010] Discectomy is also not a viable solution for DDD when no disc protrusion is involved. As mentioned above, DDD causes the entire disc to degenerate, narrowing of the intervertebral space, and shifting of the load to the facet joints. If the facet joints carry a substantial load, the joints may degrade over time and be a different cause of back pain. Furthermore, the narrowed disc space can result in the intervertebral foramina surrounding the nerve roots to directly

impinge on one or more nerve roots. Such nerve impingement is very painful and cannot be corrected by a discectomy procedure.

[0011] As a result, spinal fusion, particularly with the assistance of interbody fusion cages, has become a preferred secondary procedure, and in some instances, a preferred primary procedure. Spinal fusion involves permanently fusing or fixing adjacent vertebrae. Hardware in the form of bars, plates, screws and cages may be utilized in combination with bone graft material to fuse adjacent vertebrae. Spinal fusion may be performed as a stand-alone procedure or may be performed in combination with a discectomy procedure. By placing the adjacent vertebrae in their nominal position and fixing them in place, relative movement therebetween may be significantly reduced and the disc space may be restored to its normal condition. Thus, theoretically, aggravation caused by relative movement between adjacent vertebrae (and thus impingement on the nerve root by a disc protrusion and/or impingement from bone may be reduced if not eliminated.

[0012] However, the success rate of spinal fusion procedures is certainly less than perfect for a number of different reasons, none of which are well understood. In addition, even if spinal fusion procedures are initially successful, they may cause accelerated degeneration of adjacent discs since the adjacent discs must accommodate a greater degree of motion. The degeneration of adjacent discs simply leads to the same problem at a different anatomical location, which is clearly not an optimal solution. Furthermore, spinal fusion procedures are invasive to the disc, risk nerve damage and, depending on the procedural approach, either technically complicated (endoscopic anterior approach), invasive to the bowel (surgical anterior approach), or invasive to the musculature of the back (surgical posterior approach).

[0013] Another procedure that has been less than clinically successful is total disc replacement with a prosthetic disc. This procedure is also very invasive to the disc and, depending on the procedural approach, either invasive to the bowel (surgical anterior approach) or invasive to the musculature of the back (surgical posterior approach). In addition, the procedure may actually complicate matters by creating instability in the spine, and the long term mechanical reliability of prosthetic discs has yet to be demonstrated.

[0014] Many other medical procedures have been proposed to solve the problems associated with disc protrusions. However, many of the proposed procedures have not been clinically proven and some of the allegedly beneficial procedures have controversial clinical data. From the foregoing, it should be apparent that there is a substantial need for improvements in the treatment of spinal disorders, particularly in the treatment of nerve impingement as the result of damage to the disc, whether by injury, degradation, or the like.

SUMMARY OF THE INVENTION

[0015] The present invention addresses this need by providing improved devices and methods for the treatment of spinal disorders. As used herein, the term spinal disorder generally refers to a degradation in spinal condition as the result of injury, aging or the like, as opposed to a spinal deformity resulting from growth defects. The improved devices and methods of the present invention specifically address nerve impingement as the result of damage to the disc, particularly in the lumbar region, but may have other significant applications not specifically mentioned herein. For purposes of illustration only, and without limitation, the

present invention is discussed in detail with reference to the treatment of damaged discs in the lumbar region of the adult human spinal column.

[0016] As will become apparent from the following description, the improved devices and methods of the present invention reduce if not eliminate back pain while maintaining near normal anatomical motion. Specifically, the present invention provides dynamic bias devices and reinforcement devices, which may be used individually or in combination, to eliminate nerve impingement associated with a damaged disc, and/or to reinforce a damaged disc, while permitting relative movement of the vertebrae adjacent the damaged disc. The devices of the present invention are particularly well suited for minimally invasive methods of implantation.

[0017] The dynamic bias devices of the present invention basically apply a bias force to adjacent vertebrae on either side of a damaged disc, while permitting relative movement of the vertebrae. By applying a bias force, disc height may be restored, thereby reducing nerve impingement. Specifically, by restoring disc height, the dynamic bias devices of the present invention: retract disc protrusions into the normal disc space thereby reducing nerve impingement by the protrusions; reduce the load carried by the facet joints thereby eliminating nerve impingement originating at the joint; restore intervertebral spacing thereby eliminating nerve impingement by the intervertebral foramina; and reduce pressure on portions of the annulus thereby alleviating nerve impingement in disc fissures.

[0018] The reinforcement devices of the present invention basically reinforce a damaged disc, restore disc height and/or bear some or all of the load normally carried by a healthy disc, thereby reducing nerve impingement. Some embodiments of the reinforcement members of the present invention have a relatively small profile when implanted, but are very rigid, and thus serve to reinforce the disc, particularly the annulus. By reinforcing the disc, and particularly the annulus, disc protrusions may be reduced or prevented, thereby eliminating nerve impingement by the protrusions. Other embodiments have a relatively large profile when implanted, and thus serve to increase disc height and/or to bear load. By increasing disc height, the advantages discussed previously may be obtained. By bearing some of the load normally carried by a healthy disc, the load may be redistributed as needed, such as when a dynamic bias device is used.

BRIEF DESCRIPTION OF THE DRAWINGS

[0019] FIGS. 1A and 1B illustrate left lateral and posterior views, respectively, of a portion of the adult human vertebral (spinal) column;

[0020] FIG. 2A illustrates a left lateral view of an intervertebral disc disposed between adjacent vertebrae, wherein the disc is partially protruding from the normal disc space and the disc height is reduced;

[0021] FIG. 2B illustrates a left lateral view of an intervertebral disc disposed between adjacent vertebrae as in FIG. 2A, wherein dynamic bias devices and reinforcement devices of the present invention, which are illustrated schematically, restore normal disc height and eliminate the disc protrusion;

[0022] FIGS. 3A-3C schematically illustrate a dynamic bias device **100** in accordance with the present invention;

[0023] FIGS. 4A-4B schematically illustrate left lateral and posterior views, respectively, of dynamic bias devices of the present invention mounted to adjacent vertebrae equidistant from the median plane;

[0024] FIGS. 5A-5B schematically illustrate left lateral and posterior views, respectively, of a dynamic bias device of the present invention mounted to adjacent vertebrae in the median plane;

[0025] FIGS. 6A-6B illustrate end and exploded views, respectively, of a bushing in accordance with a first embodiment of the present invention;

[0026] FIG. 6C illustrates a posterior view of the bushing shown in FIGS. 6A-6B mounted to a spinous process;

[0027] FIG. 6D illustrates a posterior view of the spinous process shown in FIG. 6C, detailing the counter-bore;

[0028] FIGS. 7A-7B illustrate end and exploded views, respectively, of a bushing in accordance with a second embodiment of the present invention;

[0029] FIGS. 8A-8B illustrate end and exploded views, respectively, of a bushing in accordance with a third embodiment of the present invention;

[0030] FIGS. 9A-9B illustrate end and exploded views, respectively, of a bushing in accordance with a fourth embodiment of the present invention;

[0031] FIG. 10A illustrates a side view of a dynamic bias device in accordance with a first embodiment of the present invention;

[0032] FIG. 10B illustrates a side view of the dynamic bias device shown in FIG. 10A subjected to a compression load;

[0033] FIG. 10C illustrates a cross-sectional view of the dynamic bias device shown in FIG. 10A;

[0034] FIG. 11A illustrates a cross-sectional view of a dynamic bias device in accordance with a second embodiment of the present invention;

[0035] FIG. 11B illustrates a cross-sectional view of a dynamic bias device in accordance with a third embodiment of the present invention;

[0036] FIGS. 12A-12B illustrate rear and side views, respectively, of a dynamic bias device in accordance with a fourth embodiment of the present invention;

[0037] FIG. 12C illustrates the dynamic bias device shown in FIGS. 12A-12B subjected to a compression load;

[0038] FIG. 13A illustrates a side view of a dynamic bias device in accordance with a fifth embodiment of the present invention;

[0039] FIG. 13B illustrates a side or rear view of a dynamic bias device in accordance with a sixth embodiment of the present invention;

[0040] FIG. 13C illustrates a rear view of a dynamic bias device in accordance with a seventh embodiment of the present invention;

[0041] FIGS. 14A-14D illustrate tools of the present invention for implanting the reinforcement members;

[0042] FIGS. 15A-15J illustrate steps for implanting a self-expanding reinforcement member;

[0043] FIGS. 15K-15L illustrate steps for implanting an inflatable reinforcement member;

[0044] FIGS. 15M-15R illustrate steps for implanting reinforcement bars; AND

[0045] FIG. 16 illustrates a bias force v. displacement curve for the dynamic bias device.

DETAILED DESCRIPTION

[0046] The following detailed description should be read with reference to the drawings in which similar elements in different drawings are numbered the same. The drawings, which are not necessarily to scale, depict illustrative embodiments and are not intended to limit the scope of the invention.

[0047] With reference to FIGS. 1A and 1B, the lower portion of an adult human vertebral column 10 is illustrated in left lateral and posterior views, respectively. The upper portion of the vertebral column 10 includes the thoracic region and the cervical region, which are not shown for purposes of simplified illustration only. The lower portion of the vertebral column 10 includes the lumbar region 12, the sacrum 14 and the coccyx 16. The sacrum 14 and the coccyx 16 are sometimes collectively referred to as the pelvic curvature.

[0048] The vertebral column 10 includes an axis of curvature 60 which generally forms a double-S shape when viewed laterally. The vertebral column 10 also includes a median plane 70 which is a sagittal plane bisecting the vertebral column 10 into symmetrical left lateral and right lateral portions. In posterior views, the median plane 70 appears as a line.

[0049] The lumbar region 12 of the vertebral column 10 includes five (5) vertebrae 20 (labeled L1, L2, L3, L4 and L5) separated by intervertebral discs 50. The sacrum 14, which includes five (5) fused vertebrae 30 (superior vertebra 30 labeled S1), is separated by a single disc 50 from the coccyx 16, which includes four (4) fused vertebrae 40. Although not labeled, the intervertebral discs 50 may be referenced by their respective adjacent vertebrae. For example, the disc 50 between the L4 and L5 lumbar vertebrae 20 may be referred to as the L4L5 disc. Similarly, the disc 50 between the L5 lumbar vertebra 20 and the S1 sacral vertebra 30 may be referred to as the L5S1 disc.

[0050] Although each vertebra 20/30/40 is a unique and irregular bone structure, the vertebrae 20 of the lumbar region 12 (in addition to the thoracic and cervical regions) have common structures. Each vertebra 20 of the lumbar region 12 generally includes a body portion 21 and a vertebral arch portion 22/23 which encloses the vertebral foramen (not visible) in which the spinal cord is disposed. The vertebral arch 22/23 includes two pedicles 22 and two laminae 23. A spinous process 24 extends posteriorly from the juncture of the two laminae 23, and two transverse processes 25 extend laterally from each lamina 23. Four articular processes 26/27 extend inferiorly 26 and superiorly 27 from the laminae 23. The inferior articular process 26 rests in the superior articular process 27 of the adjacent vertebra to form a facet joint 28.

[0051] The five (5) vertebrae 30 of the sacrum 14 are fused together to form a single rigid structure. The sacrum 14 includes a median sacral crest 31 which roughly corresponds to the spinous processes of the vertebrae 30, and two intermediate sacral crests 32 which roughly correspond to the articular processes of the vertebrae 30. The sacral laminae 33 are disposed between the median 31 and intermediate 32 sacral crests. Two lateral sacral crests 34 are disposed on either side of the sacral foraminae 35. The sacrum 14 also includes a pair of sacral wings 36 which define auricular surfaces 39. The superior (S1) sacral vertebra 30 includes two superior articular processes 37 which engage the inferior articular processes 26 of the L5 lumbar vertebra 20 to form a facet joint, and the base 38 of the superior sacral vertebra S1 is joined to the L5S1 disc 50.

[0052] Each intervertebral disc 50 includes an annulus fibrosus 52 surrounding a nucleus pulposus 54, which are more clearly visible in FIG. 15A. The posterior annulus 52 is generally thinner than the anterior annulus 52, which may account for the higher incidence of posterior disc protrusions. As used herein, a disc protrusion generically refers to any portion of the disc that protrudes from the normal disc space.

Common clinical conditions that may be characterized as a disc protrusion include a disc stenosis, a disc bulge, a herniated or sequestered disc, a slipped disc, and a prolapsed disc. Generally, a disc protrusion results in a decrease in disc height proportional to the volume of the protrusion. A degenerative disc may sometimes only involve the loss of disc height, and may or may not involve any significant protrusion. However, both degenerative discs and a disc protrusions usually involve some loss in disc height.

[0053] A common theory is that each intervertebral disc **50** forms one support point and the facet joints form two support points of what may be characterized as a three point support structure between adjacent vertebrae. However, in the lumbar region **12**, the facet joints **28** are substantially vertical, leaving the disc **50** to carry the vast majority of the load. As between the annulus fibrosus **52** and the nucleus pulposus **54** of the disc **50**, it is commonly believed that the nucleus **54** bears the majority of the load. This belief is based on the theory that the disc **50** behaves much like a balloon or tire, wherein the annulus **22** merely serves to contain the pressurized nucleus **54**, and the nucleus **54** bears all the load.

[0054] However, this theory is questionable since the annulus fibrosus **52** comprises 60% of the total disc **50** cross-section, and the nucleus pulposus **54** only comprises 40% of the total disc **50** cross-section. In addition, the annulus fibrosus **52** is made of 40-60% organized collagen in the form of a laminated structure, whereas the nucleus pulposus **54** is made of 18-30% collagen in the form of a relatively homogenous gel. It seems a more plausible theory is that the annulus fibrosus **52** is the primary load bearing portion of the disc **50**.

[0055] With reference to FIG. 2A, a left lateral view of an intervertebral disc **50** disposed between adjacent vertebrae **20_s** (superior) and **20_r** (inferior) is illustrated, wherein the disc **50** is partially protruding **56** from the normal disc space and the disc height is reduced. Although the disc **50** is shown to include a protrusion **56**, the reduction in disc height may or may not be accompanied with a protrusion **56** as discussed previously. For example, if the disc **50** is degenerated, the disc height may be reduced with or without a corresponding protrusion **56**.

[0056] It should be understood that the vertebrae shown in FIGS. 2A and 2B generically refer to any two adjacent vertebrae or any series of adjacent vertebrae, and that lumbar vertebrae **20_s** and **20_r** are specifically shown for purposes of illustration only. This generic method of illustrating vertebrae also applies to the remainder of the Figures.

[0057] With reference to FIG. 2B, a left lateral view of the intervertebral disc **50** disposed between adjacent vertebrae **20_s** and **20_r** is illustrated as in FIG. 2A. However, in this Figure, devices **100** and **200** of the present invention, which are illustrated schematically, eliminate the disc protrusion **56** and restore normal disc height. Specifically, one or more dynamic bias devices **100** and one or more reinforcement members **200** are utilized, either in combination or individually.

[0058] The dynamic bias device **100** restores disc height and, by conservation of disc volume, retracts the protrusion into the normal disc space thereby reducing nerve impingement by the protrusion. Restoring disc height also reduces the load carried by the facet joints thereby eliminating nerve impingement originating at the joint, restores intervertebral spacing thereby eliminating nerve impingement by the inter-

vertebral foramina, and reduces pressure on portions of the annulus thereby alleviating nerve impingement in disc fissures.

[0059] The dynamic bias device **100** basically applies a bias force to the adjacent vertebrae **20_s** and **20_r** to which it is connected, but allows relative movement of the vertebrae **20_s** and **20_r**. The dynamic bias device **100** is conceptually similar to a spring attached to the adjacent vertebrae **20_s** and **20_r**. The dynamic bias device **100** applies a bias force (usually repulsive) between the vertebrae **20_s** and **20_r** when the disc height is normal or less than normal. The bias force is preferably set such that the disc height is normal with normal posture and loading, and increases with posterior flexure and/or added vertical load. The details of the design and use of the dynamic bias device **100** will be discussed in greater detail hereinafter, particularly with reference to FIGS. 3A-3C, 4A-4B, 5A-5B, 10A-10C, 11A-11B, 12A-12C, and 13A-13C.

[0060] Because most protrusions **56** are posterior, the dynamic bias device **100** is preferably mounted posterior to the axis of curvature **60**. Locating the dynamic bias device **100** posterior to the axis of curvature **60** shifts the load carried by the disc **50** from the posterior portion of the disc to the anterior portion of the disc **50**. Locating the dynamic bias device **100** posterior to the axis of curvature **60** also reduces the load carried by the facet joints. Preferably, the dynamic bias device **100** applies a substantially vertical bias force, with the direction independent of displacement.

[0061] Because more load will be shifted to the anterior portion of the disc **50** with a posterior mounted dynamic bias device **100**, reinforcement members **200** may be placed in the anterior annulus **52**, to effectively bolster the anterior portion of the disc. The reinforcement members **200** may be used to reinforce the disc, restore disc height and/or bear the load normally carried by annulus. The reinforcement members **200** are relatively rigid and thus serve to reinforce the disc **50** where inserted. In addition, the reinforcement members **200** may have a relatively large profile when implanted and thus increase disc height. The reinforcement members **200** are particularly beneficial if the disc **50** is degenerated, or if the disc **50** will likely become degenerated with the change in load distribution. The details of the design and use of the reinforcement members **200** will be discussed in greater detail hereinafter, particularly with reference to FIGS. 14A-14D and 15A-15R.

[0062] As mentioned previously, one or more dynamic bias devices **100** and one or more reinforcement members **200** may be utilized, either alone or in combination. Specifically: one or more dynamic bias devices **100** may be used alone; one or more spacer devices **200** may be used alone; and one or more dynamic bias devices **100** and one or more reinforcement members **200** may be used in combination. If a combination of devices **100/200** is used, it is believed that the use of one or more posterior dynamic bias devices **100** in combination with one or more anterior reinforcement members **200** is most effective in treating posterior protrusions **56**, facet joint degradation, and nerve impingement by intervertebral foraminae, which are believed to be the most common culprits of chronic LBP.

[0063] As an alternative to the arrangement shown in FIG. 2B, two or more dynamic bias devices **100** may be attached to the vertebrae on opposite sides of vertebrae **20_s** and **20_r**. Specifically, one or more dynamic bias devices **100** is connected to vertebra **20_s** and the vertebra immediately superior to vertebra **20_s**, and one or more dynamic bias devices **100** is

connected to vertebra 20_7 and the vertebra immediately inferior to vertebra 20_1 . With this arrangement, the dynamic bias devices 100 are primarily applying a traction force to effectively pull vertebrae 20_S and 20_7 apart, thereby eliminating the disc protrusion 56 and restoring normal disc height.

[0064] With reference to FIGS. 3A-3C, the dynamic bias device 100 is schematically illustrated under conditions of no-load, compression load (L_C), and traction load (L_T), respectively. The dynamic bias device 100 includes a pair of attachment members 102 , a bias member 104 , and a housing 106 . Attachment members 102 facilitate attachment of the dynamic bias device 100 to vertebrae 20_S and 20_7 , as shown in FIG. 2B. Bias member 104 functions to apply a bias force between the attachment members 102 . Housing 106 functions to separate the moving portions of dynamic bias device 100 from the surrounding muscle, ligaments and other tissue when the dynamic bias device 100 is implanted.

[0065] Attachment members 102 may comprise a wide variety of mechanical connection designs, and may incorporate into their design, or be used in combination with, other machine elements not specifically mentioned herein. For purposes of illustration only, the each attachment member 102 is shown as loop which may be connected to the vertebrae by fasteners and bushings, specific examples of which are described in detail with reference to FIGS. 6A-6D, 7A-7B, 8A-8B and 9A-9B. These specific examples are provided by way of example, not limitation. Those skilled in the art will recognize that the attachment members 102 may comprise or include screws, rivets, spikes, keys, pins, cotters, splines, couplings, bushings, washers, and the like, without departing from the scope or spirit of the present invention.

[0066] The primary function of the attachment members 102 is to fixedly secure the ends of the bias member 104 to the vertebrae 20_S and 20_7 . Preferably, the attachment members 102 are secured to the vertebrae 20_S and 20_7 such that translational movement is minimized or eliminated, and such that rotational movement is permitted between each attachment member 102 and each vertebrae 20_S and 20_7 . Providing attachment members 102 with these functional attributes permits the dynamic bias device 100 to effectively transmit a bias force to each vertebrae 20_S and 20_7 , allow relative movement therebetween, and minimize stress on the vertebrae 20_S and 20_7 at the attachment points.

[0067] Bias member 104 functions to apply a bias force, either attraction or repulsion, between the attachment members 102 . The bias force generally increases or decreases with displacement of the ends of the bias member 104 , as with a conventional spring. In addition, the bias force may increase or decrease with the time derivative of displacement (i.e., velocity) of the ends of the bias member 104 , as with a conventional damper or shock absorber. As shown in FIG. 3B, the bias member 104 compresses in response to a compression load (L_C), thereby increasing or decreasing the bias force. Similarly, as shown in FIG. 3C, the bias member 104 extends in response to a traction load (L_T), thereby increasing or decreasing the bias force.

[0068] If the dynamic bias devices 100 are attached to vertebrae 20_S and 20_7 (compression embodiment), as shown in FIG. 2B, the bias force of the bias member 104 increases in response to a compression load (L_C), and decreases in response to a traction load (L_T). In addition, the bias member 104 normally operates in compression. Preferably, the bias force of the bias member 104 is adjusted such that the disc is restored to a more normal height when the dynamic bias

device 100 is implanted. Because the disc height is usually initially less than normal, the dynamic bias device 100 is attached to the vertebrae with the bias member 104 preloaded in compression or with the vertebrae 20_C and 20_7 in traction or otherwise spread apart. In this manner, for a given posture, the disc height will be larger following implantation of the dynamic bias device 100 than prior to implantation.

[0069] If the dynamic bias devices 100 are attached to the vertebrae on opposite sides of vertebrae 20_S and V (traction embodiment), as discussed as an alternative to the arrangement shown in FIG. 2B, the bias force of the bias member 104 decreases in response to a compression load (L_C), and increases in response to a traction load (L_T). With this latter arrangement, the bias member 104 normally operates in tension. Because the bias member 104 normally operates in tension with this arrangement, the bias member 104 may simply comprise a member that is rigid or semi-rigid in tension, such as a cable. Also with this arrangement, the bias force of the bias member 104 is adjusted such that the disc is restored to a more normal height when the dynamic bias device 100 is implanted. Further with this arrangement, because the disc height is usually initially less than normal, the dynamic bias device 100 is attached to the vertebrae with the bias member 104 preloaded in tension or with the vertebrae 20_S and 20_7 in traction or otherwise spread apart.

[0070] With either arrangement, the dynamic bias device 100 preferably operates with substantially linear displacement substantially parallel to the axis of curvature 60 . However, the amount of displacement will be evenly shared between the dynamic bias devices 100 in the traction embodiment, whereas the compression embodiment requires the full displacement to be assumed by each dynamic bias device 100 . The following ranges of displacement are given with reference to the compression embodiment. When mounted near the posterior portion of adjacent spinous processes, the dynamic bias device 100 may have a total (i.e., maximum) displacement preferably in the range of 1.0 to 3.0 cm to accommodate full posterior to anterior flexure in the L5-S1 region, 0.5 to 1.5 cm to accommodate full posterior to anterior flexure in the L4-L5 region, and 0.25 to 1.0 cm to accommodate full posterior to anterior flexure in the L1-L4 region.

[0071] Within these ranges of displacement, it is preferable that bias member 104 operate within its elastic limit, as dictated by the chosen material and geometry of the bias member 104 . In addition, because the bias member preferably should be able to withstand 1.0 to 10 million fatigue cycles, it is preferable that bias member 104 operate within its fatigue limit, as dictated by the chosen material and geometry, for the full range of displacement.

[0072] As mentioned previously, the bias force may generally increase or decrease with displacement of the ends of the bias member 104 , as with a conventional spring. In this situation, the bias force (F_B) is generally governed by Hooke's Law where $F_B = K\Delta X$, wherein F_B is linearly proportional to the displacement (ΔX) as dictated by the spring constant (K) of the bias member 104 . Also as mentioned previously, the bias force may increase or decrease with the time derivative of displacement (i.e., velocity) of the ends of the bias member 104 , as with a conventional damper or shock absorber. In this situation, the bias force (F_B) is generally linearly proportional to the derivative of displacement ($\Delta X/\Delta T$) as dictated by the damper constant (P) of the bias member 104 . Preferably, the bias force F_B of the bias member 104 is adjusted such that the disc is restored to a more normal height when the dynamic

bias device **100** is implanted. The bias force F_B may be adjusted by selecting the spring constant (K) and/or damper constant (P) of the bias member **104** and by pre-loading (compressing) the bias member **104** an initial displacement ΔX_r .

[0073] The necessary bias force F_B may be roughly calculated as a function of body weight (BW), the distance of the mounted dynamic bias device **100** from the axis of curvature **60**, and the mechanical properties of the surrounding tissues (muscle tissue, connective tissue, joints). The normal net load carried by the lumbar region **12** is roughly 30% BW when laying down, 140% BW when standing, 185% BW when sitting, 215% BW when bending forward, and 250% BW when slouching.

[0074] With reference to FIG. 16, a bias force versus attachment point displacement curve for the dynamic bias device **100** is shown. The bias force is intended to be sufficiently high to spread the attachment points (e.g., processes of adjacent vertebrae) and restore normal disc height in all postures. For example, in normal standing posture, the bias force is sufficiently high to spread the attachment points as shown in FIG. 16, such that more normal disc size and shape is obtained. As the spine is placed in flexion and extension, the amount of force carried by the dynamic bias device **100** will change as a function of the spring properties, including the spring constant (K) and the compression length of the spring.

[0075] In a preferred embodiment, the bias force is sufficient to shift the pre-implant (normal posture) distance to the post-implant (normal posture) distance. To prevent excessive compression of the disc, particularly the posterior disc, it is also preferred that the bias force increase significantly as the attachment points come closer, as by extension, lifting and/or poor posture. This is facilitated by the natural increase in bias force of the spring as the distance decreases, and is aided by the damper pad and the compression limit (bottomed out) of the spring. In addition, because the dynamic bias device is intended to limit excessive compression of the posterior disc, and not necessarily intended to limit flexion of the spine, it is also preferable that the bias force approach zero (spring fully extended) at a distance which is less than the extension limit of the dynamic bias device.

[0076] Thus, by way of example, not limitation, the bias force may be in the range of 1% to 30% BW when laying down. With other postures after implantation, the bias force may be estimated by subtracting the contribution of body weight from the load carried by lumbar region **12**, which is approximately 50% BW (head=5% BW; arms=9% BW; trunk=36% BW). As such, the bias force may be in the range of 10% to 90% BW when standing.

[0077] With reference to FIGS. 4A-4B and 5A-5B, left lateral and posterior views of dynamic bias devices **100** are schematically illustrated as being mounted to adjacent spinous processes **24_S** and **24_r** of adjacent vertebrae **20_S** and **20_r**. When two or more dynamic bias devices **100** are utilized per pair of vertebrae as shown in FIGS. 4A and 4B, the dynamic bias devices **100** are preferably mounted substantially equidistant from the median plane **70**, or otherwise symmetric about the median plane **70**, in order to avoid causing lateral bias or curvature of the spine **10**. Note that the dynamic bias devices **100** may be mounted substantially vertical as shown or at an angle to the median plane **70** and satisfy these criteria. When only one dynamic bias device **100** is utilized per pair of vertebrae as shown in FIGS. 5A and 5B,

the dynamic bias device **100** is preferably mounted in or near the median plane **70** for the same reason.

[0078] Although it is preferable to have the dynamic bias device(s) **100** near the median plane **70**, substantially equidistant from the median plane **70**, or otherwise symmetric about the median plane **70**, it is possible to have multiple dynamic bias devices **100** mounted asymmetrically while maintaining balanced bias forces about the median plane **70**. The objective is to avoid causing lateral bias or curvature of the spine **10**, which is a function of balancing bias forces and moments about the median plane **70**.

[0079] The bias forces are vectors which have a magnitude governed by the properties of the bias member **104**, and a direction dictated by the mounting position of the dynamic bias device **100**. Each dynamic bias device **100** has two bias force vectors, one for each attachment member **102** at each attachment point. Each bias force vector has a moment arm equal to the distance from the attachment point to the median plane **70**. For each attachment point, the product of the moment arm and the vertical component of the bias force vector is the moment or torque applied to the spine **10**, and the horizontal component of the bias force vector is the shear applied to the spine **10**. Thus, in order to minimize curvature of the spine **10**, all of the moments are balanced about the median plane **70**. In order to minimize lateral bias on the spine **10**, all of the horizontal components of the bias force vectors are balanced about the median plane **70**. The easiest way to accomplish this result, of course, is to mount the dynamic bias devices **100** symmetrically about the median plane **70**. However, those skilled in the art will recognize that asymmetric mounting arrangements that substantially meet these criteria are also possible.

[0080] Further, because most protrusions **56** are posterior, the dynamic bias device(s) **100** is/are preferably mounted posterior to the axis of curvature **60**. This is advantageous because loss of disc height is most common in the posterior disc **50**, the largest amount of mechanical advantage about the anterior disc is obtained posterior to the axis of curvature **60**, and the posterior portions of the vertebrae are easiest to access less invasively. However, the dynamic bias device(s) **100** may be mounted at any position relative to the axis of curvature **60** depending on the location of the protrusion **56**, as long as the dynamic bias device(s) **100** is/are near the median plane **70**, substantially equidistant from the median plane **70**, or otherwise symmetric about the median plane **70** as discussed above.

[0081] Given these criteria, there are many suitable mounting locations or attachment points for the dynamic bias device **100**. Some of the possible attachment points are labeled A-N in FIGS. 1A and 1B. Attachment points A-G refer to the lumbar vertebrae **20** (L1-L5), and attachment points H-N refer to the sacral vertebrae **30** (particularly S1). The attachment points A-G of the lumbar region **12** are equally applicable to the thoracic and cervical regions of the spine **10**, which are not illustrated for purposes of simplicity only.

[0082] In the lumbar region **12**, attachment points A and B refer to the left lateral and right lateral surfaces of the spinous process **24**; attachment point C refers to the posterior surface of the spinous process **24**; attachment points D and E refer to the posterior surfaces of the left and right laminae **23**; and attachment points F and G refer to the distal ends of the left and right transverse processes **25**.

[0083] In the sacrum **14**, attachment points H and I refer to the left lateral and right lateral surfaces of the superior median

sacral crest **31**; attachment points K and L refer to the posterior surfaces of the sacral laminae **33** between the median sacral crest **31** and the intermediate sacral crests **32**; and attachment points M and N refer to posterior surface between the intermediate sacral crests **32** and the lateral sacral crests **34**.

[0084] A wide variety of sets of attachment points are possible, a non-exhaustive list of which is set forth herein. For single dynamic bias device **100** mounting, the nomenclature is $(X_1 Y_1)$ where X_1 is the attachment point on vertebra X, and Y_1 is the attachment point on vertebra Y. For double dynamic bias device **100** mounting, the nomenclature is $(X_1 Y_1, X_2 Y_2)$ where X_1 is the attachment point of the first dynamic bias device **100** on vertebra X, Y_1 is the attachment point of the first dynamic bias device **100** on vertebra Y, X_2 is the attachment point of the second dynamic bias device **100** on vertebra X, and Y_2 is the attachment point of the second dynamic bias device **100** on vertebra Y. Vertebrae X and Y refer to any two different vertebrae, which are usually, but not necessarily, adjacent. In addition, vertebrae X and Y may be superior and inferior, respectively, or vice-versa.

[0085] To illustrate the attachment point nomenclature, reference may be made to FIGS. **4B** and **5B**. In FIG. **4B**, a first dynamic bias device **100** is attached to the left lateral surface of the two spinous processes, and a second dynamic bias device **100** is attached to the right lateral surface of the two spinous processes. Thus, the set of attachment points for the arrangement of FIG. **4B** is (AA, BB). In FIG. **5B**, only one dynamic bias device **100** is attached to the posterior surface of the two spinous processes. Thus, the set of attachment points for the arrangement of FIG. **5B** is (CC).

[0086] By way of example, not limitation, the following sets of attachment points may be used to satisfy the above-referenced criteria with regard to balancing moments and forces about the median plane **70**. For single dynamic bias device **100** mounting: (CC); and (CJ) are preferred. For double dynamic bias device **100** mounting: (AA, BB); (DD, EE); (FF, GG); (AH, BI); (DK, EL); (FK, GL); (DM, EN); and (FM, GN) are preferred. Also for double dynamic bias device **100** mounting: (AD, BE); (AF, BG); (AK, BL); (AM, BN); (DH, EI); (DF, EG); (FH, GI); (CA, CB); (CH, CI); (CD, CE); (CF, CG); (CK, CL); (CM, CN); (JA, JB); (JH, JI); (JD, JE); and (JF, JG) are possible. For more than double mounting, any combination of these sets may be used. Generally, the more posterior the attachment points, the less invasive the procedure will be. Attachment points A, B, C, H and I are preferred for this reason. In addition, to avoid interfering with the motion of the vertebrae, the dynamic bias device **140** is preferably disposed laterally or posteriorly of the spinous processes **24**, as opposed to under and between the spinous processes **24**.

[0087] The dynamic bias device **100** may be attached to these points by conventional surgical techniques, except as described herein. The posterior musculature and connective tissues may be dissected to expose the desired attachment points. If desired, any disc protrusions **56** may be removed, in whole or in part, using a conventional discectomy procedure. Also if desired, any other abnormal spinal growths or protrusions may be removed. However, for many disc protrusions **56**, it is anticipated that conventional traction or separation techniques may be employed to temporarily retract the protrusion **56** into the normal disc space until the dynamic bias devices are implanted.

[0088] In order to establish separation of the vertebrae, the spine may be placed in traction or conventional intervertebral separation tools may be used. Alternatively, the dynamic bias device **100** may be preloaded such that when the device is released after attachment, the bias force establishes the desired amount of separation.

[0089] Pilot holes are drilled as needed, such as for the use of bushings **330**, **340** and/or **350** (described with reference to FIGS. **7A-7B**, **8A-8B** and **9A-9B** hereinafter). If attachment points A, B, H and I are to be used, such as with the use of bushing **320** (described with reference to FIGS. **6A-6D** hereinafter), a hole **90** and counter-bore **92** may be drilled into the spinous process **24**. The device(s) **100** are then attached to the desired attachment points in accordance with the hardware being used, and the site is subsequently surgically closed.

[0090] With reference to FIGS. **6A-6D**, **7A-7B**, **8A-8B** and **9A-9B**, various embodiments of bushings **320**, **330**, **340**, and **350**, respectively, are illustrated. As mentioned previously, the attachment members **102** may comprise a wide variety of mechanical connection designs, and may incorporate into their design, or be used in combination with, other machine elements such as bushings **320**, **330**, **340**, and **350**. Bushings **320**, **330**, **340**, and **350** are adapted to mount one or two dynamic bias devices **100**. As illustrated, bushings **320**, **330**, **340**, and **350** are adapted to receive attachment members **102** in the form of loops or the like, but may be modified to receive other structures. A primary function of bushings **320**, **330**, **340**, and **350** is to isolate movement of the attachment members **102** from the vertebrae to which they are attached. Thus, the bushing to bone (vertebrae) interface is static, while the bushing to attachment member interface is dynamic. This reduces if not eliminates the abrasive degradation of the vertebrae due to the attachment of the dynamic bias device **100**. The orientation of the vertebral surface at the attachment points will determine the best bushing scheme.

[0091] With reference to FIGS. **6A-6B**, end and exploded views, respectively, of a bushing **320** are illustrated. Bushing **320** is particularly suitable for attachment to the spinous process **24** as shown in FIG. **6C**, or attachment points A, B, H and I as illustrated in FIG. **1A**. Bushing **320** may be attached to the spinous process **24** utilizing a conventional fastener **300**, which includes bolt **302**, nut **304** and washers **306** and **308**. Preferably, the fastener **300** is a lock fastener such that it will not have a tendency to unscrew with relative motion of the attachment members **102**. However, the nut **304** is not tightened so much as to inhibit rotational movement of the attachment members **102**. Fastener **300** may alternatively comprise a key and pin (e.g., cotter pin). When fully assembled, the attachment members **102** are disposed around the shaft of the bolt **302** on either side of the bushing **320** and between the washers **306** and **308**.

[0092] Bushing **320** includes a male fitting **321** which fits into a female fitting **324**. The male fitting **321** includes a shank portion **322** and a head portion **323**. Similarly, the female fitting **324** includes a shank portion **325** and a head portion **326**. The female fitting **324** has an inside diameter sized to accommodate the shank **322** of the male fitting **321**, and the male fitting **321** has an inside diameter sized to accommodate the bolt **302** of the fastener **300**. The outside surface of the shank **322** of the male fitting **321** and the inside surface of the shank **325** of the female fitting **324** may include mating threads.

[0093] The size of the head **323/326** to bone interface is preferably maximized to minimize stress concentration and

to distribute torsional loads over a large surface area. The size of the female shank 25 and the corresponding size of the hole 90 drilled through the spinous process 24 are chosen to minimize stress concentration and minimize the loss of bone integrity. A counter-bore 92 may be used to flatten and thereby maximize the contact surface area of the head 323/326 to bone interface, as illustrated in FIG. 6D.

[0094] The materials of the fastener 300 and bushing 320 may comprise any suitable implantable material capable of withstanding high fatigue. For example, all components could be comprised of 300 or 400 series stainless steel, titanium alloy 6-4, or MP35N alloy. Preferably, all components would be made of the same or similar material to reduce galvanic corrosion. The surfaces of the fastener 300 and bushing 320 that engage the attachment members 102 of the dynamic bias device 100 are preferably smooth to reduce friction and wear. The surfaces of the bushing 320 that engage the vertebrae may have a roughened surface (e.g., knurled) to reduce the likelihood of relative movement therebetween. In addition, the surfaces of the bushing 320 that engage the vertebrae may have a porous sintered surface to facilitate solid bone growth, thereby further securing the bushing 320. Coatings and surface treatments may be utilized to reduce or increase friction where desired, and biological response where tissue interface is likely.

[0095] With reference to FIGS. 7A-7B, end and exploded views, respectively, of a bushing 330 are illustrated. Except as described herein, bushing 330 is substantially the same in design, function and use as bushing 320. Bushing 330 is adapted to mount one or (preferably) two dynamic bias devices 100. Bushing 330 is particularly suitable for attachment points C and J as illustrated in FIG. 1B. Bushing 330 may be attached to the vertebrae 20/30 utilizing a conventional bone screw 310, which may be modified in diameter, length and thread type for the particular attachment site and condition.

[0096] Bushing 330 includes two male fittings 331 which fit into a female fitting 334. The male fittings 331 each include a shank portion 332 and a head portion 333. Similarly, the female fitting 334 includes two shank portions 335 and two head portions 336. The female fitting 334 has an inside diameter sized to accommodate the shanks 332 of the male fittings 331, and the male fittings 331 have an inside diameter sized to accommodate the bolt 302 of the fastener 300. The outside surfaces of the shanks 332 of the male fittings 331 and the inside surfaces of the shanks 335 of the female fitting 334 may include mating threads. When fully assembled, the attachment members 102 are disposed around the shanks 335 on either side of heads 336 of the female fitting 334 and between the heads 333 of the male fittings 331.

[0097] With reference to FIGS. 8A-8B, end and exploded views, respectively, of a bushing 340 are illustrated. Except as described herein, bushing 340 is substantially the same in design, function and use as bushing 330. Bushing 340 is adapted to mount one dynamic bias device 100. Bushing 340 is particularly suitable for attachment points C, D, E, F, G, J, K, L, M and N, but may also be used for attachment points A, B, H and I as illustrated in FIGS. 1A and 1B. Bushing 340 may be attached to the vertebrae 20/30 utilizing a conventional bone screw 310, which may be modified in diameter, length and thread type for the particular attachment site and condition.

[0098] Bushing 340 includes a male fitting 341 which fits into a female fitting 344. The male fitting 341 includes a shank

portion 342 and a head portion 343. Similarly, the female fitting 344 includes a shank portion 345 and a head portion 346. The female fitting 344 also includes a flange 347 connecting the bone screw 310 to the bushing 340. The female fitting 344 has an inside diameter sized to accommodate the shank 342 of the male fitting 341, and the male fitting 341 has an inside diameter sized to accommodate the bolt 302 of the fastener 300. The outside surface of the shank 342 of the male fitting 341 and the inside surface of the shank 345 of the female fitting 344 may include mating threads. When fully assembled, the attachment member 102 is disposed around the shank 345 on the female fitting 344 and between the heads 343/346 of the fittings 341/344. When mounted, the axis of the shank 345 of bushing 340 is oriented parallel to the mounting surface.

[0099] With reference to FIGS. 9A-9B, end and exploded views, respectively, of a bushing 350 are illustrated. Except as described herein, bushing 350 is substantially the same in design, function and use as bushing 340. Bushing 350 is adapted to mount one dynamic bias device 100. Bushing 350 is particularly suitable for attachment points C, D, E, F, G, J, K, L, M and N, but may also be used for attachment points A, B, H and I as illustrated in FIGS. 1A and 1B. Bushing 350 may be attached to the vertebrae 20/30 utilizing a conventional bone screw 310, which may be modified in diameter, length and thread type for the particular attachment site and condition. In this particular embodiment, the fastener 300 is formed integrally with the bone screw 310.

[0100] Bushing 350 includes a male fitting 351 which fits into a female fitting 354. The male fitting 351 includes a shank portion 352 and a head portion 353. Similarly, the female fitting 354 includes a shank portion 355 and a head portion 356. The female fitting 354 has an inside diameter sized to accommodate the shank 352 of the male fitting 351, and the male fitting 351 has an inside diameter sized to accommodate the bolt 302, which is integral with the bone screw 310. The outside surface of the shank 352 of the male fitting 351 and the inside surface of the shank 355 of the female fitting 354 may include mating threads. When fully assembled, the attachment member 102 is disposed around the shank 355 on the female fitting 354 and between the heads 353/356 of the fittings 351/354. When mounted, the axis of the shank 355 of bushing 350 is oriented perpendicular to the mounting surface.

[0101] With reference to FIGS. 10A-10C, side views of a dynamic bias device 110 are illustrated in a no-load condition, in a compression load condition, and in cross-section, respectively. Except as described herein, dynamic bias device 110 is substantially the same in design, function and use as the generic device 100 described previously. Dynamic bias device 110 includes a barrel 111 in which piston 112 is slidably disposed. A bias member in the form of a spring 113 is disposed in the barrel 111. Longitudinal displacement of the barrel 111 relative to the piston 112 causes compression (or extension) of the spring 113. The spring 113 provides a bias force which increases (or decreases) linearly with displacement as discussed previously. A flexible housing (not shown) may be placed about the dynamic bias device 110 to isolate the moving parts 111/112 from the surrounding tissue when implanted.

[0102] An adjustable arm 114 may be connected to the piston 112. The arm 114 and the barrel 111 include holes 115 or other suitable attachment members, which may be used in combination bushings 320, 330, 340 and 350, to attach the

dynamic bias device **110** to the vertebrae. The adjustable arm **114** and the piston **112** may include mating threads such that rotation of the arm **114** causes the arm **114** to effectively lengthen or shorten the piston **112**. This allows the distance between the holes **115** to be varied to accommodate different attachment locations and different anatomies. This also allows the dynamic bias device to be preloaded by extending the effective length of the piston **112** beyond the distance between attachment points.

[0103] A collar **116** is provided to limit the extended length of the dynamic bias device **110**. The collar **116** may include threads that mate with threads inside the barrel **111** such that the collar **116** is adjustable, and thus the extended length is adjustable. The collar **116** may also include an elastomeric bumper pad to dampen impact between the piston **112** and the collar when the device **110** is fully extended. Similarly, an elastomeric bumper pad **117** may be provided in the barrel **111** to dampen impact between the piston **112** and the barrel **111** when the device **110** is fully collapsed.

[0104] With reference to FIG. 11A, a cross-sectional view of a dynamic bias device **120** is illustrated. Except as described herein, dynamic bias device **120** is substantially the same in design, function and use as dynamic bias device **110** discussed with reference to FIGS. 10A-10C. Dynamic bias device **120** includes a barrel **121** in which piston **122** is slidably disposed. A bias member **123** in the form of a compressed or evacuated fluid (liquid or gas or a combination of both) is disposed in the barrel **121** and sealed relative to the piston **122** by piston ring **128**. The barrel **121** and piston **122** may define a closed volume or an exhaust reservoir **129** may be used as shown. The bias fluid **123** is in fluid communication with the exhaust reservoir **129** by way of an exhaust port through the wall of the barrel **121**. The exhaust reservoir **129** may comprise an expandable annular bag as shown, or other suitable structure. If a closed volume is used, longitudinal displacement of the barrel **121** relative to the piston **122** simply causes a change in pressure of the fluid **123**. If an exhaust reservoir **129** is used as shown, longitudinal displacement of the barrel **121** relative to the piston **122** causes a change in pressure of the fluid **123** and flow of fluid **123** into the exhaust reservoir **129** via the exhaust port. The pressure of the fluid **123** and the size of the exhaust hole dictates the bias force which increases (or decreases) with the time derivative of displacement as discussed previously.

[0105] A flexible housing (not shown) may be placed about the dynamic bias device **130** to isolate the moving parts **121/122** from the surrounding tissue when implanted. The housing may be used to define the exhaust reservoir **129**. An adjustable arm **124** may be connected to the piston **122**. The arm **124** and the barrel **121** include holes **125** or other suitable attachment members to attach the dynamic bias device **120** to the vertebrae. The adjustable arm **124** and the piston **122** may include mating threads to effectively lengthen or shorten the piston **122**. An adjustable collar **126** may be provided including mating threads such that the collar **126** is adjustable, and thus the extended length of the dynamic bias device **120** is adjustable. The collar **126** may include an elastomeric bumper pad (not shown) and an elastomeric bumper pad **127** may be provided in the barrel **121** to dampen impact between the piston **122** and the barrel **121**.

[0106] With reference to FIG. 11B, a cross-sectional view of a dynamic bias device **130** is illustrated. Except as described herein, dynamic bias device **130** is substantially the same in design, function and use as the combination of

dynamic bias device **110** discussed with reference to FIGS. 10A-10C and dynamic bias device **120** described with reference to FIG. 11A.

[0107] Dynamic bias device **130** includes a barrel **131** in which piston **132** is slidably disposed. A bias member in the form of a spring **133A** is disposed in the barrel **131**. Longitudinal displacement of the barrel **131** relative to the piston **132** causes compression (or extension) of the spring **133**. The spring **133** provides a bias force which increases (or decreases) linearly with displacement as discussed previously. In addition, a bias member **133B** in the form of a compressed or evacuated fluid (liquid or gas) is disposed in the barrel **131** and sealed relative to the piston **132** by piston ring **138**.

[0108] The barrel **131** and piston **132** may define a closed volume or an exhaust reservoir **129** may be used as shown. The bias fluid **133** is in fluid communication with the exhaust reservoir **139** by way of an exhaust port through the wall of the barrel **131**. The exhaust reservoir **139** may comprise an expandable annular bag as shown, or other suitable structure. If a closed volume is used, longitudinal displacement of the barrel **131** relative to the piston **132** simply causes a change in pressure of the fluid **133**. If an exhaust reservoir **139** is used as shown, longitudinal displacement of the barrel **131** relative to the piston **132** causes a change in pressure of the fluid **133** and flow of fluid **133** into the exhaust reservoir **139** via the exhaust port. The pressure of the fluid **133** and the size of the exhaust hole dictates the bias force which increases (or decreases) with the time derivative of displacement as discussed previously. Thus, the bias members **133A/133B** effectively act as a combined spring and damper.

[0109] A flexible housing (not shown) may be placed about the dynamic bias device **130** to isolate the moving parts **131/132** from the surrounding tissue when implanted. The housing may be used to define the exhaust reservoir **139**. An adjustable arm **134** may be connected to the piston **132**. The arm **134** and the barrel **131** include holes **135** or other suitable attachment members to attach the dynamic bias device **130** to the vertebrae. The adjustable arm **134** and the piston **132** may include mating threads to effectively lengthen or shorten the piston **132**. An adjustable collar **136** may be provided including mating threads such that the collar **136** is adjustable, and thus the extended length of the dynamic bias device **130** is adjustable. The collar **136** may include an elastomeric bumper pad (not shown) and an elastomeric bumper pad **137** may be provided in the barrel **131** to dampen impact between the piston **132** and the barrel **131**.

[0110] With reference to FIGS. 12A-12B, rear and side views of dynamic bias device **140** are illustrated in no-load condition. FIG. 12C illustrates the dynamic bias device **140** subjected to a compression load. Except as described herein, dynamic bias device **140** is substantially the same in design, function and use as the generic device **100** described previously. Although movement of the dynamic bias device **140** in compression and extension is substantially linear and parallel to the axis of curvature **60**, as with dynamic bias device **100**, some lateral or posterior-anterior motion is present, but preferably minimized. Dynamic bias device **140** includes bias member **142** and loops **144** or other suitable attachment members, which may be used in combination bushings **320**, **330**, **340** and **350**, to attach the dynamic bias device **140** to the vertebrae. The bias member **142** may be a semi-circular or semi-elliptical leaf spring, which may be a single plate as shown or a series of laminated plates. Relative longitudinal

displacement of the attachment members **144** causes compression (or extension) of the leaf spring **142**. The leaf spring **142** provides a bias force which increases (or decreases) with displacement as discussed previously.

[0111] The radius or axis of curvature of the leaf spring **142** is preferably maximized such that displacement of the attachment members **144** is substantially linear, but should not be so high as to result in buckling or inversion in compression. By way of example, not limitation, the radius or axis of curvature may range from half the distance between the attachment points to approximately 10 cm. Of course, half the distance between attachment points will vary depending on the location of each attachment point, but will likely be in the range of 1.0 to 3.0 cm for attachment points between adjacent processes.

[0112] The displacement of the apex **143** is preferably of the leaf spring **142** minimized to minimize disturbance of and interference from surrounding tissue (bone, muscle, connective tissue, nerves, etc.). The apex **143** may face anteriorly, but preferably faces posteriorly or laterally to reduce interference with tissue close to the spinal column. The dynamic bias device **140**, and particularly the leaf spring **142**, is preferably disposed laterally or posteriorly of the spinous processes **24** to avoid interference with movement of the vertebrae.

[0113] With reference to FIGS. **13A-13C**, various alternative dynamic bias devices **150**, **160** and **170** are illustrated in side and posterior views. Except as described herein, dynamic bias devices **150**, **160** and **170** are substantially the same in design, function and use as the dynamic bias device **140** discussed with reference to FIGS. **12A-12C**.

[0114] Dynamic bias device **150** as seen in FIG. **13A** includes bias member **152** in the form of an articulated leaf spring, and attachment members **154**. Articulated leaf spring **152** reduces the horizontal range of movement by utilizing a plurality of articulations **153** having a smaller radius or axis of curvature. The reduced horizontal range of movement of the bias member **152** reduces the amount of disturbance and interference from surrounding tissue (bone, muscle, connective tissue, nerves, etc.).

[0115] Dynamic bias device **160** as seen in FIG. **13B** includes a plurality of bias members **162** in the form of leaf springs (shown) or articulated leaf springs (not shown), and attachment members **164**. Utilizing a plurality of leaf springs **162** increases stability of the dynamic bias device **160** and allows for greater net bias forces to be delivered to the attachment members **164** and the vertebrae attached thereto.

[0116] Dynamic bias device **170** as seen in FIG. **13C** includes a plurality of bias members **172** in the form of leaf springs (shown) or articulated leaf springs (not shown). The dynamic bias device **170** also includes attachment members **174** in the form of inverted semi-circular loops. The inverted semi-circular loops **174** permit the device **170** to be attached to the inferior and superior sides spinous processes of adjacent vertebrae, such that the attachment members **174** are disposed between adjacent spinous processes but the bias members **172** are disposed laterally of the spinous processes to avoid interference with movement of the vertebrae.

[0117] Dynamic bias devices **110**, **120**, **130**, **140**, **150**, **160** and **170** may be used (i.e., implanted) substantially as described with reference to generic dynamic bias device **100**. As mentioned previously, one or more reinforcement members **200** may be used in combination with one or more dynamic bias devices **100**. The reinforcement members **200** may be used to reinforce the disc, restore disc height and/or

bear some or all of the load normally carried by the annulus. The reinforcement members **200** are relatively rigid and thus serve to reinforce the disc **50**, and particularly the annulus **52**, where inserted. In addition, the reinforcement members **200** may have a relatively large profile when implanted and thus increase disc height.

[0118] The reinforcing members **200** may be used singularly or in groups, depending on the increase in disc **50** height desired and/or the amount of reinforcement of the annulus **52** desired. For example, the reinforcing members **200** may be stacked as illustrated in FIG. **2B** or inserted side-by-side as illustrated in FIG. **15R**. In addition, the reinforcing members **200** may be located in virtually any portion of the annulus **52**. Preferably, the reinforcing members **200** are substantially symmetrically disposed about the median plane **70** to avoid causing curvature of the spine **10**. Although the reinforcing members **200** may be inserted, in part or in whole, into the nucleus **54**, it is preferable to insert them into the annulus **52** for purposes of stability and load carrying. Specifically, to provide stability, it is desirable to symmetrically locate the reinforcing members **200** as far as reasonably possible from the median plane **70**, or to span as great a distance as possible across the median plane **70**. In addition, because the annulus **52** of the disc **50** is believed to carry the majority of the load, particularly in the lumbar region **12**, the reinforcing members **200** are preferably placed in the annulus **52** to assume the load normally carried thereby, and reinforce the load bearing capacity of the annulus **52**, without hindering the normal mobility function of the disc **50**.

[0119] The reinforcing members **200** may comprise expandable members such as self-expanding members **210** or inflatable members **220**. Alternatively, the reinforcing members **200** may comprise unexpandable members such as reinforcement bars **230**. When implanting each type of reinforcement member **210/220/230**, it is preferable to maintain the integrity of the annulus **52**. Accordingly, space in the annulus **52** for the reinforcing members **200** is preferably established by dilation or the like, although some amount of tissue removal may be used.

[0120] The expandable reinforcement members **210/220** are useful because they may be delivered in a low profile, unexpanded condition making it easier to traverse the very tough and fibrous collagen tissue of the annulus **52**. For similar reasons, the reinforcement bars **230** are useful because they may have a small diameter and a sharpened tip. Although it is possible to insert the expandable reinforcing members **210/220** into the annulus **52** in their final expanded state, it is desirable to deliver the expandable reinforcing members **210/220** into the annulus **52** in an unexpanded state and subsequently expand them in order to minimize invasiveness and resistance to insertion.

[0121] The self-expanding reinforcing member **210** may comprise a solid or semi-solid member that self-expands (e.g., by hydration) after insertion into the annulus. Examples of suitable materials for such solid or semi-solid members include solid fibrous collagen or other suitable hard hydrophilic biocompatible material. If the selected material is degradable, the material may induce the formation of fibrous scar tissue which is favorable. If non-degradable material is selected, the material must be rigid and bio-inert. The self-expanding reinforcing member **210** preferably has an initial diameter that is minimized, but may be in the range of 25% to 75% of the final expanded diameter, which may be in the range of 0.3 to 0.75 cm, or 10% to 75% of the nominal disc

height. The length of the self-expanding member **210** may be in the range of 1.0 to 6.0 cm, and preferably in the range of 2.0 to 4.0 cm.

[0122] The inflatable reinforcing member **220** may comprise an expandable hollow membrane capable of inflation after insertion into the annulus. An example of a suitable inflatable structure is detachable balloon membrane filled with a curable material. The membrane may consist of a biocompatible and bio-inert polymer material, such as polyurethane, silicone, or polycarbonate-polyurethane (e.g., Corethane). The curable filler material may consist of a curable silicone or polyurethane. The filler material may be curable by chemical reaction (e.g., moisture), photo-activation (e.g., UV light) or the like. The cure time is preferably sufficiently long to enable activation just prior to insertion (i.e., outside the body) and permit sufficient time for navigation and positioning of the member **220** in the disc. However, activation may also take place inside the body after implantation. The inflatable reinforcing member **220** preferably has an initial deflated diameter that is minimized, but may be in the range of 25% to 75% of the final inflated diameter, which may be in the range of 0.3 to 0.75 cm, or 10% to 75% of the nominal disc height. The length of the inflatable member **220** may be in the range of 1.0 to 6.0 cm, and preferably in the range of 2.0 to 4.0 cm.

[0123] The reinforcement bars **230** may comprise a rigid, solid or hollow bar having a sharpened tip. The reinforcement bars **230** may comprise stainless steel mandrels, for example, having a diameter in the range of 0.005 to 0.100 inches, preferably in the range of 0.010 to 0.050 inches, and most preferably in the range of 0.020 to 0.040 inches, and a length in the range of 1.0 to 6.0 cm, and preferably in the range of 2.0 to 4.0 cm. The reinforcement bars **230** may be straight for linear insertion, or curved to gently wrap with the curvature of the annulus during insertion. In addition, the outer surface of the reinforcement bars **230** may have circular ridges or the like that permit easy insertion into the annulus **52** but resist withdrawal and motion in the annulus following implantation. Other suitable materials for reinforcement bars **230** include titanium alloy 6-4, MP35N alloy, or super-elastic nickel-titanium alloy.

[0124] Referring now to FIGS. 14A-14D, various tools **410**, **420** and **430** are shown individually and assembled. The tools **410**, **420** and **430** may be used to implant the reinforcement devices **210/220/230** discussed above. The tools include a rigid, sharpened, hollow needle **410**, a semi-rigid, sharpened, hollow curved needle **420**, and a sharpened stylet **430**. As seen in FIG. 14D, the sharpened stylet **430** fits into the semi-rigid needle **420** which fits into the rigid needle **410**.

[0125] With specific reference to FIG. 14A, the rigid hollow needle **410** includes a hollow shaft **412** and a grip or handle **414**. The shaft **412** includes a sharpened tip **413** to facilitate insertion into and pass through the surrounding tissue. The shaft **412** is preferably made of a rigid metal such as a stainless steel hypodermic tube. The grip **414** may comprise a polymer and may be formed by insert injection molding with the shaft **412** inserted into the mold.

[0126] With specific reference to FIG. 14B, the semi-rigid curved needle **420** includes a hollow shaft **422** a hub **424**. The shaft **422**, which includes a sharpened tip **423**, is longer than the rigid needle **410** and has an outside diameter sufficiently small to fit into the rigid needle **410**. The shaft **422** is preferably made of a semi-rigid polymer or composite. The shaft **422** includes a curved distal portion **426** that may be straight-

ened (shown in phantom) upon insertion of the semi-rigid needle **420** into the lumen of the rigid needle **410**. The hub **424** may include a fitting **425** to facilitate connection to a fluid source or a pressure source (e.g., a syringe).

[0127] With specific reference to FIG. 14C, the sharpened stylet **430** includes a flexible shaft **432** and a sharpened distal end **433**. The shaft **432** is longer than both the rigid needle **410** and the semi-rigid needle **420**, and may have a length on the order of 10 to 60 cm. The shaft **432** also has an outside diameter sufficiently small to fit into the semi-rigid needle **420**. The shaft **422** preferably has a flexible but pushable construction incorporating a rigid metal such as stainless steel, or super-elastic nickel-titanium alloy. The sharpened stylet **430** is preferably highly elastic, to resist permanent set upon insertion into the curved portion **426** of the semi-rigid needle **420**.

[0128] With general reference to FIGS. 15A-15J, the steps for implanting a self-expanding reinforcement member **210** are illustrated. It should be understood that the procedure for implanting a single member **210** in the anterior annulus **52** is shown for purposes of illustration, not limitation. All of the variables with regard to quantity, location, orientation, etc. discussed previously may be implemented by varying the generic procedure described hereinafter.

[0129] Initially, the sharpened stylet **430**, semi-rigid needle **420** and rigid needle **410** are assembled as shown in FIG. 14D. As shown in FIG. 15A, the distal portion of the assembly **410/420/430** is inserted into the disc **50** as in a conventional discogram procedure. The assembly **410/420/430** is advanced until the distal tip **413** of the rigid needle is proximate the anterior curvature of the annulus **52**, near the anterior side of the nucleus **54**, as seen in FIG. 15B. The semi-rigid needle **420** (alone or with stylet **430**) is advanced relative to the rigid needle **410** until the curved portion **426** of the semi-rigid needle exits the distal tip **413** of the rigid needle **410** and the desired amount of curvature is established, as seen in FIG. 15C. The curved portion **426** may be advanced until the tip **423** is substantially parallel to the tangent of the anterior annulus **52** curvature. The sharpened stylet **430** is advanced relative to the semi-rigid needle **420** to the desired position within the anterior annulus **52**, as shown in FIG. 15D. The semi-rigid needle **420** and the rigid needle **410** are completely withdrawn from the stylet **430**, leaving the stylet in position as shown in FIG. 15E.

[0130] A flexible dilator **440** is advanced over the stylet **430** to dilate the annulus **52**, as seen in FIG. 15F. The flexible dilator **440** is similar to semi-rigid needle **420** except that the dilator includes a blunt distal tip and is relatively more flexible, and has larger inner and outer diameters. Note that one or more dilators **440** may be advanced co-axially about the stylet **430** until the annulus is sufficiently dilated to accept the self-expandable member **210**. The stylet **430** is then withdrawn from the flexible dilator **440** and the self-expandable member **210** is introduced into the lumen of the flexible dilator **440** using a push bar **450**, as shown in FIG. 15G. Alternatively, the dilator **440** may be removed in favor of a flexible hollow catheter with a large inner diameter to facilitate delivery of member **210**. The push bar **450** is similar to stylet **430** except that the distal tip of the push bar **450** is blunt. Alternatively, the push bar **450** may simply comprise the stylet **430** turned around, thus using the proximal blunt end of the stylet **430** as the push bar **450**. The push bar **450** is advanced until the member **210** is in the desired position, as seen in FIG. 15H. To facilitate positioning the member **210**,

radiographic visualization may be used to visualize the distal end of the push bar 450, which is formed of radiopaque material and may include radiopaque markers. In addition, the member may be loaded with a radiopaque material to facilitate radiographic visualization thereof.

[0131] After the member 210 is in the desired position, the flexible dilator 440 is retracted from the push bar 450 while maintaining position of the member 210 with the push bar. The push bar 450 is then removed leaving the member 210 in place. If necessary, the procedure may be repeated for additional member implants 210. The member 210 is then allowed to expand over time, perhaps augmented by placing the spine 10 in traction. Alternatively, the spine 10 may be placed in traction prior to beginning the procedure as discussed with reference to the procedure for implanting dynamic bias device 100.

[0132] With reference to FIGS. 15K-15L, the steps for implanting an inflatable reinforcement member 220 are illustrated. In this procedure, the steps outlined with reference to FIGS. 15A-15F are followed. Specifically, the same steps are followed up to and including the step of advancing the flexible dilator 440 over the stylet 430 to dilate the annulus 52, and thereafter removing the stylet 430 from the flexible dilator 440. Using a catheter 460, the inflatable member 220 is introduced into the dilator 440 and advanced until the member 220 is in the desired position, as shown in FIG. 15K. The inflatable member 220 is connected to the distal end of the catheter 460, which includes a flexible but pushable shaft 462 and an inflation port 464. The flexible dilator 440 is retracted from the catheter 460 while maintaining position of the member 220.

[0133] With the member 220 in the desired position, which may be confirmed using radiographic visualization as described above, the proximal inflation port 464 is connected to a syringe (not shown) or other suitable inflation apparatus for injection of the curable filler material. The filler material is then activated and the desired volume is injected into the catheter 460 via the inflation port 464, as seen in FIG. 15L. The filler material is allowed to cure and the catheter 460 is gently torqued to break the catheter 460 from the solid member 220. This break-away step may be facilitated by an area of weakness at the juncture between the distal end of the catheter 460 and the proximal end of the member 220. The catheter 460 is then removed leaving the member 220 in place. If necessary, the procedure may be repeated for additional member implants 220.

[0134] With reference to FIGS. 15M-15R, the steps for implanting a reinforcement bar 230 are illustrated. As seen in FIG. 15M, the disc 50 includes a protrusion or bulge 56, which is preferably, but not necessarily, reduced or eliminated before insertion of the reinforcement bar 230. This may be done by separating the adjacent vertebrae 20. In order to establish separation of the vertebrae 20, the spine 10 may be placed in traction or conventional intervertebral separation tools may be used. After the bulge 56 is reduced or eliminated, similar steps are followed as outlined with reference to FIGS. 15A-15C.

[0135] Delivery of a single reinforcement bar 230 into the posterior annulus 52 is illustrated. Specifically, the distal portion of the assembly 410/420/450 is inserted into the disc 50 in a conventional discogram procedure. The assembly 410/420/450 is advanced until the distal tip 413 of the rigid needle 410 just penetrates the posterior side of the annulus 52, as seen in FIG. 15N. The semi-rigid needle 420 (alone or with bar 230) is advanced relative to the rigid needle 410 until the

curved portion 426 of the semi-rigid needle 420 exits the distal tip 413 of the rigid needle 410 and the desired amount of curvature is established, as shown in FIG. 15N. The curved portion 426 may be advanced until the tip 423 is substantially parallel to the posterior annulus 52.

[0136] Using the push bar 450, the reinforcement bar 230 with its sharpened tip is pushed into the annulus 52 as seen in FIG. 15O. The reinforcement bar 230 is advanced into the annulus 52 with the push bar 450 until the bar 230 is in the desired position, as seen in FIG. 15P, which may be confirmed using radiographic visualization as described above. The push bar 450 is then retracted, leaving the reinforcement bar 230 in place, as shown in FIG. 15P. The semi-rigid needle 420 and the rigid needle 410 are then removed, as shown in FIG. 15Q, or, if necessary, the procedure may be repeated for additional reinforcement bar implants 230, as shown in FIG. 15R. Presence of the reinforcement bars 230 serves to keep the disc 50, and particularly the bulge 56, in a more normal condition, and to protect against continued bulging, thus easing nerve impingement.

[0137] From the foregoing, those skilled in the art will appreciate that the present invention provides dynamic bias devices 100, 110, 120, 130, 140, 150, 160, and 170, in addition to reinforcement devices 210, 220, and 230, which may be used individually or in combination, to eliminate nerve impingement associated with a damaged disc 50, and/or to reinforce a damaged disc, while permitting relative movement of the vertebrae 20.sub.S and 20.sub.I adjacent the damaged disc. The present invention also provides minimally invasive methods of implanting such devices as described above.

[0138] Those skilled in the art will recognize that the present invention may be manifested in a variety of forms other than the specific embodiments described and contemplated herein. Accordingly, departures in form and detail may be made without departing from the scope and spirit of the present invention as described in the appended claims.

1. A surgical implant for treating spinal disorders, said implant comprising:

- a first attachment member adapted to be attached to a posterior vertebral protrusion of a superior vertebrae;
- a second attachment member adapted to be attached to a posterior vertebral protrusion of an inferior vertebrae;
- and

- a dynamic bias device attached to the first and second attachment members, wherein said first and second attachment members are positioned, and the dynamic bias device is adapted, so that the surgical implant applies a distracting force between the superior and inferior vertebrae sufficient for selectively maintaining the first and second vertebrae at a predetermined distance.

2. The surgical implant of claim 1 wherein the dynamic bias device is further adapted to be compressed in response to a second force that exceeds the distracting force.

3. The surgical implant of claim 1 wherein the dynamic bias device includes an elastomeric material residing between the coupling of said first and second attachment members.

4. The surgical implant of claim 1 wherein the dynamic bias device includes a flexible housing.

5. The implant of claim 1, wherein said posterior vertebral protrusion is one of the group consisting of pedicles, articular processes, spinous processes, and transverse processes.

6. A system for treating spinal disorders, said system comprising at least two surgical implants, further comprising:

- a first surgical implant including first and second attachment members and a dynamic bias device applying a bias force connected therebetween;
 - a second surgical implant including first and second attachment members and a dynamic bias device applying a bias force connected therebetween;
 - the first attachment members being adapted to connect to respective posterior vertebral protrusions of a superior vertebrae; and
 - the second attachment members being adapted to connect to respective posterior vertebral protrusions of an inferior vertebrae.
7. The system of claim 6, wherein said bias force is an attraction bias.
 8. The system of claim 6, wherein said bias force is a repulsion bias.
 9. The system of claim 6, wherein said first attachment member is adapted to connect to a superior spinous process.
 10. The system of claim 6, wherein said second attachment member is adapted to connect to an inferior spinous process.
 11. The system of claim 6, wherein said first attachment member is adapted to connect to a superior transverse process.
 12. The system of claim 6, wherein said second attachment member is adapted to connect to an inferior transverse process.
 13. The system of claim 6 wherein the first attachment members connect to the same posterior vertebral protrusions of a superior vertebrae.
 14. The system of claim 6 wherein the second attachment members connect to different posterior vertebral protrusions of an inferior vertebrae.
 15. The system of claim 6, wherein said posterior vertebral protrusion is selected from the group consisting of pedicles, articular processes, spinous processes, and transverse processes.
 16. A surgical implant for treating spinal disorders, said implant comprising:
 - means for providing one or more dynamic bias devices; and
 - means for adapting a first dynamic bias device for a first attachment to a first posterior vertebral protrusion, and a second attachment to a second posterior vertebral protrusion,
 wherein the one or more dynamic bias devices include an elastomeric material residing between the coupling of said first and second attachment members.
 17. The surgical implant of claim 16 further comprising means for removing at least a portion of spinal tissue.

18. The surgical implant of claim 16, wherein said posterior vertebral protrusions are selected from the group consisting of pedicles, articular processes, spinous processes, and transverse processes.
19. The surgical implant of claim 16 further comprising means for adapting a second dynamic bias device of the one or more dynamic bias devices for a first attachment to a first posterior vertebral protrusion, and a second attachment to a second posterior vertebral protrusion.
20. A method for treating spinal disorders, said method comprising:
 - providing one or more dynamic bias devices; and
 - adapting a first one of the one or more dynamic bias devices for a first attachment to a first posterior vertebral protrusion of a first vertebrae, and a second attachment to a second posterior vertebral protrusion of a second vertebrae.
21. The method of claim 20 further comprising adapting a second one of the one or more dynamic bias devices for a first attachment to a first posterior vertebral protrusion, and a second attachment to a second posterior vertebral protrusion.
22. The method of claim 20, wherein said posterior vertebral protrusion is one or more of the group consisting of pedicles, articular processes, spinous processes, and transverse processes.
23. The method of claim 20 wherein said one or more dynamic bias devices is adjusted by selecting the spring constant (K) and/or damper constant (P) of the bias member that results in a normal disc height.
24. The method of claim 20 further comprising selecting a distracting force between the first and second vertebrae sufficient for maintaining the first and second vertebrae at a predetermined distance.
25. The method of claim 24, wherein said one or more dynamic bias devices is compressed in response to a second force that exceeds said distracting force.
26. The method of claim 20, wherein said one or more dynamic bias devices include an elastomeric material residing between the coupling of said first and second attachment members.
27. A surgical implant for treating spinal disorders, said implant comprising:
 - a first attachment member adapted to be attached to a posterior vertebral protrusion of a superior vertebrae;
 - a second attachment member adapted to be attached to a posterior vertebral protrusion of an inferior vertebrae; and
 - a dynamic bias device attached to the first and second attachment members,
 wherein said device is adapted to allow motion between the first and second attachment members.

* * * * *