

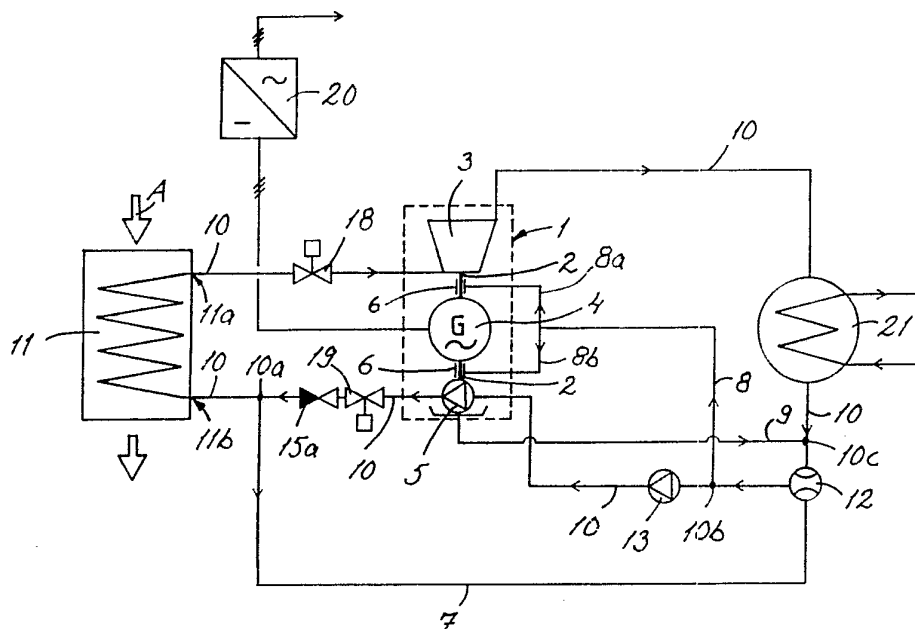

INTERNATIONAL APPLICATION PUBLISHED UNDER THE PATENT COOPERATION TREATY (PCT)

<p>(51) International Patent Classification ⁵ : F01D 25/22</p>	<p>A1</p>	<p>(11) International Publication Number: WO 92/05342 (43) International Publication Date: 2 April 1992 (02.04.92)</p>
<p>(21) International Application Number: PCT/FI91/00295 (22) International Filing Date: 25 September 1991 (25.09.91) (30) Priority data: 904720 26 September 1990 (26.09.90) FI (71) Applicant (for all designated States except US): OY HIGH SPEED TECH. LTD. [FI/FI]; Box 306, SF-33101 Tampere (FI). (72) Inventors; and (75) Inventors/Applicants (for US only) : KYTÖMÄKI, Timo [FI/FI]; Linnunrata 5, SF-53850 Lappeenranta (FI). LINDGREN, Olli [FI/FI]; Mannerheimintie 58 C 59, SF-00260 Helsinki (FI). ALAMÄKI, Jarmo [FI/FI]; Välikatu 27, SF-53200 Lappeenranta (FI). LARJOLA, Jaakko [FI/FI]; PPA 1 Varpanen, SF-52700 Mäntyharju (FI).</p>		<p>(74) Agent: KAHILAINEN, Hannu; Tampereen Patenttitoimisto Oy, Kanslerinkatu 6, SF-33720 Tampere (FI). (81) Designated States: AT (European patent), BE (European patent), CA, CH (European patent), DE (European patent), DK (European patent), ES (European patent), FR (European patent), GB (European patent), GR (European patent), IT (European patent), JP, LU (European patent), NL (European patent), SE (European patent), US. Published <i>With international search report.</i></p>

(54) Title: METHOD FOR SECURING THE LUBRICATION OF BEARINGS IN A HERMETIC HIGH-SPEED MACHINE



(57) Abstract

The object of the invention is a method for arranging the fluid lubrication of bearings (6) of a rotor (2) of a closed or hermetic high-speed machine (1), especially a small-size power plant based on the Organic Rankine Cycle (ORC) process, i.e. an energy converter, comprising a turbine (3), a generator (4), and possibly a main feed pump (5) installed on a joint rotor (2), wherein organic circulating medium of the process is used for lubrication. According to the invention, in a stoppage situation of the primary circulation in the main line (10) of the energy converter, the fluid lubrication of the bearings (6) of the rotor (2) is secured by pressurized circulating medium accumulated in the vaporizer (11), such as a boiler, process furnace, ceramic furnace, or a corresponding heat source, as a result of the closing of the main operational valve.

FOR THE PURPOSES OF INFORMATION ONLY

Codes used to identify States party to the PCT on the front pages of pamphlets publishing international applications under the PCT.

AT	Austria	ES	Spain	MG	Madagascar
AU	Australia	FI	Finland	ML	Mali
BB	Barbados	FR	France	MN	Mongolia
BE	Belgium	GA	Gabon	MR	Mauritania
BF	Burkina Faso	GB	United Kingdom	MW	Malawi
BG	Bulgaria	GN	Guinea	NL	Netherlands
BJ	Benin	GR	Greece	NO	Norway
BR	Brazil	HU	Hungary	PL	Poland
CA	Canada	IT	Italy	RO	Romania
CF	Central African Republic	JP	Japan	SD	Sudan
CG	Congo	KP	Democratic People's Republic of Korea	SE	Sweden
CH	Switzerland	KR	Republic of Korea	SN	Senegal
CI	Côte d'Ivoire	LI	Liechtenstein	SU ⁺	Soviet Union
CM	Cameroon	LK	Sri Lanka	TD	Chad
CS	Czechoslovakia	LU	Luxembourg	TG	Togo
DE*	Germany	MC	Monaco	US	United States of America
DK	Denmark				

⁺ Any designation of "SU" has effect in the Russian Federation. It is not yet known whether any such designation has effect in other States of the former Soviet Union.

Method for securing the lubrication of bearings in a hermetic high-speed machine

The object of the invention is a method in a hermetic
5 small-size power plant, especially in one based on
the Organic Rankine Cycle (ORC) process, comprising a
system consisting of a high-speed machine, vaporiser,
and condenser which are connected by a main line for
effecting the primary circulation, wherein the high-
10 speed machine comprises a turbine, a generator and
possibly a main feed pump mounted on a joint rotor,
and wherein the bearing of the rotor is arranged to
be carried out by fluid lubrication and particularly
in a situation of continuing operation of the process
15 through the condenser along the main line of primary
circulation.

The small-size power plant based on the ORC process
was developed especially for the recovery of waste
20 heat from various heat-producing processes or machines
where, due to the temperature of the waste heat or
due to the circumstances of the environment, waste
heat cannot be used as such or by means of heat
exchangers or corresponding means. By a small-size
25 power plant, waste heat is converted generally by a
turbine to electricity which is easily used for
different purposes.

It can be shown thermodynamically that the Organic
30 Rankine Cycle process is the best applicable method
for this kind of energy converting. The heat of
vaporization of an organic substance is low in relation
to e.g. the heat of evaporation of water, and its
fall of specific enthalpy in the turbine is small and
35 the mass flow rate in relation to the output is high,
wherein it is possible to reach a high turbine ef-
ficiency even in a range of small capacity.

A hermetic or fully closed-circuit process has the advantage that there are no leaks and the process is thus reliable and durable in operation.

5 The utilization of high-speed technology, wherein the turbine is directly coupled with a generator rotating at the same speed and thus producing high-frequency current, has made it possible to further simplify the process in a way that e.g. a separate reduction gear
10 required by conventional processes as well as shaft inlets are not needed.

A hermetic energy converter of this kind, operating on high-speed technology and based on the ORC process,
15 is known from the publication FI-66234, according to which the bearing of the rotor of the high-speed machine is carried out by an organic circulating medium, wherein the circulating medium is in a gaseous state. Thus it is possible to reach a very high
20 efficiency, because the losses of gaseous bearing are very small. However, for reasons of manufacturing techniques, bearings lubricated with fluid circulating medium have been shown to be more cost-saving.

25 The use of the circulating medium in a liquid state in the said bearing system is known e.g. from US-Patent 2,961,550 which relates to the bearings of a power plant by a circulating medium, with special respect to starting up a power plant. According to the publi-
30 cation, the said bearing system is effected by condensing the circulating medium from a gaseous state into a liquid state by a separate condenser, whereafter the fluid circulating medium is directed to the bearings. With particular attention to starting up
35 the power plant, its bearing pipework is equipped with a valve that operates on the basis of the pressure of the circulating medium and opens at an essentially lower pressure than the main valve in the pipework of

the primary circulation, wherein the lubrication of bearings starts before the start of the turbine.

5 In the small-size power plant or energy converter systems in use, a problem has arisen in connection with different stoppage situations due to disturbances, failures and corresponding reasons when the primary circulation to the turbine must be discontinued and the lubrication of the bearings of the rotor in the
10 high-speed machine is discontinued or significantly reduced in the present systems during a stopping situation. Thus the technique used, by which the rotor generally rotates at the synchronous speed of the network (3000 rpm), results in insufficient
15 lubrication which wears down the bearings and essentially reduces their time in use.

The method according to this invention makes it possible to obtain a decisive improvement to the
20 disadvantages presented above and thus to raise the level of technology in the field. To reach this objective, it is characteristic to the method according to this invention that in a stoppage situation of the primary circulation in the main line of the process,
25 the fluid lubrication of the bearings of the rotor is arranged from the vaporizer of the energy converter, such as from a boiler, a process furnace, a ceramic furnace or corresponding, by means of pressurized circulating medium accumulated in the vaporizer.

30 One of the most important advantages of the method according to the invention is the essentially longer uninterrupted duty cycles of the high-speed machine, and thus also of the entire energy converter, as well
35 as the essentially longer time of use of the bearings of the said rotor. Also, the controllability of the entire process of the energy converter in a stoppage situation is essentially improved.

In the other independent claims, advantageous applications of the method according to the invention are presented.

5

The following explanation demonstrates the invention in detail and also refers to the attached drawings wherein

10 Figure 1 presents an operating diagram of a first embodiment of the method according to the invention in a typical ORC process in principle, and

15 Figure 2 presents an alternative operating diagram of a second embodiment of the method according to the invention in a typical ORC process in principle.

20 The method according to the invention is intended for application in processes similar to those presented in Figures 1 and 2, wherein the primary circulation 10 of the small-size power plant or the energy converter is effected in a way that evaporator 11, such as a
25 boiler, process furnace, ceramic furnace or corresponding, evaporates the organic circulating medium, such as different Freons or toluene, which further expands in turbine 3, is condensated in condenser 21, and is returned by pump/pumps 5, 12, 13, 14 to evaporator 11 wherein the flow of circulating medium during
30 the normal drive of the process to the turbine is controlled by adjusting the main operating valve 18 and/or the operating valve 19. The heat energy produced by the evaporator 11 in the circulating medium is
35 converted in the high-speed machine 1 by generator 4 which rotates at the same speed as turbine 3 into high-frequency electricity which is further rectified/inverted in the further processing 20 to be applicable

for later uses. In the normal drive, the hydrodynamic bearings 6 are lubricated by the fluid circulating medium along the pipeline 8 from the pressure side of pump 12 or 14.

5

Because the organic medium, contrary to steam, is usually superheated when expanded, the efficiency of the process can be further improved with respect to the applications presented by installing a separate preheater or recuperator between turbine 3 and vaporizer 21. The number of pumps needed in the process depends on the pressure level of the circulating medium, which is affected by the features of the circulating medium used, the temperature of the heating gas flow A, the height differences of the pipework in the process and other corresponding factors, in which case, with low pressure level, the feed pump 5 connected to rotor 2 of the turbine 3 and generator 4 is not necessarily needed in the high-speed machine 1.

10
15
20

In practice, a permanently magnetized generator, presented in a greater detail in the publication FI-71640, has been useful as generator 4. Furthermore, it is practical to use hydrodynamic rolling-segment type bearings, whose structure and operating principle is presented in more detail in e.g. the publication Glacier: Tilting Pod Journal Bearings, Designers Handbook No. 10, as bearings 6.

25
30
35
In a typical ORC process according to Fig. 1, the method according to the invention is realized in a way that in a stoppage situation of the primary circulation of the main line 10, wherein the main operational valve 18 in the main line 10 is closed, the temperature development in vaporizer 11 continues, wherein the circulating medium accumulated in the vaporator is vaporized. Because of evaporation, the pressure level of the circulating medium rises in

vaporizer 11. The rise in the pressure level results in the discharge of the circulating medium in a liquid state at the inlet side 11b of the vaporizer and its further passage controlled by the barrier organ 15a in the main line 10 from the branch point 10a of the main line to the flow organ 7 which discharges into fluid ejector 12. By the action of fluid ejector 12, the circulating medium passes further, when the pre-feed pump 13 is stopped and the operating valve 19 closed, from the branch point 10b of the main line via the second flow organ 8 to the bearings 6 of rotor 2, and after lubrication at the third flow organ 9 back to the suction side of the fluid ejector 12 of main line 10. The flow organs 7 and 8 operate as flow organs conveying circulating medium to the high-speed machine with the purpose of lubrication, and the third flow organ 9 operates as a flow organ for returning circulating medium as a lubricant from the high-speed machine.

20

Due to the general principles of measurement in the circulation process, the inner volume of vaporizer 11 containing circulating medium is related to the inner volumes of the flow organs 7, 8, 9 and the bearings 6 in a way that after closing of the main operating valve 18, a possible stoppage of operation of vaporizer 11 which is due to an increase in pressure and/or temperature of the circulating medium accumulated in vaporizer 11, and which is effected by an inner safety device in vaporizer 11, such as a guard for boiling dry or corresponding, occurs essentially later than closing of the main operational valve 18, wherein the lubrication of bearings 6 is secured for the time required for stopping rotor 2, in practice for at least 30 seconds after the closing of the main operational valve 18. In the most common systems, the volume of vaporizer 11 is manifold as compared with the stopping stage which normally takes for approx.

30 seconds. Thus the said circuit provides for the fluid lubrication of bearings during the stopping of the rotor in all failure situations.

5 In a typical ORC process according to Fig. 2, the method according to the invention is realized in an alternative way that in a stoppage situation of the primary circulation of the main line 10 (e.g. when pre-feed pump 14 stops), wherein the main operational
10 valve 18 in the main line 10 is closed, the temperature development in vaporizer 11 continues, wherein the circulating medium accumulated in the vaporizer is vaporized. Because of evaporation, the pressure level of the circulating medium rises in vaporizer 11 in a way that the pressure level is highest at the outlet
15 side 11a and lowest at the inlet side 11b. The rise in pressure level results in the discharge of the circulating medium in a liquid state from the inlet side 11b of the vaporizer and its passage by the
20 barrier organ 15a in the main line 10 from the branch point 10a of the main line via the first flow organ 7 to the branch point 10b on the pressure side of the pre-feed valve 14 in the main line 10, wherein the pressure level of the circulating medium is adjusted
25 by an organ 17 in the said flow organ 7, such as a pressure reducing valve or corresponding. From the branch point 10b of the main line, the circulating medium is further conveyed by pressure and directed by barrier organ 15b between the branch point 10b and
30 pre-feed pump 14 through the second flow organ 8 to the bearings 6 of rotor 2, and after lubrication by the third flow organ 9 back to the suction side of pre-feed pump 14 of main line 10. Because of the general principles of the construction of the circulating
35 process, the inner volume of vaporizer 11 containing circulating medium is related to the inner volumes of flow organs 7, 8, 9 and bearings 6 in a way that after the main operational valve 18 is closed, a

possible operational stoppage of either vaporizer 11, due to the increase of pressure and/or temperature of the circulating medium accumulated in vaporizer 11 by an inner safety device in vaporizer 11, such as a guard for boiling dry, or a stoppage of the flow through the first flow organ 7 by an organ 16 in the first flow organ 7, such as a temperature-controlled valve or corresponding, takes place essentially later than the closing of the main operational valve 18, wherein the fluid lubrication of the bearings 6 is secured for the time of stopping of rotor 2, in practice at least 30 seconds after the closing of the main operational valve 18. Thus the said circuit provides for the fluid lubrication of bearings during the stopping of the rotor in all failure situations.

It is obvious that the invention is not limited to the applications presented above, but it can be modified within the basic idea even to a great extent. For instance, the circulating medium accumulated in the vaporizer can be used in a vaporized state, wherein the vapour, e.g. according to US-Patent 2,961,550 mentioned above, is condensated by condenser 21 or by a separate condenser into the liquid state, whereafter the fluid circulating medium is conveyed to the bearings according to the invention. It should also be noted that the drawings presented are primarily operational embodiments in principle, wherein the pipework equipment may in practical applications vary or be more complete as to the valves, pumps, etc.

Claims:

1. Method in a hermetic small-size power plant, especially in one based on Organic Rankine Cycle (ORC) process, comprising a system consisting of a high-speed machine (1), vaporizer (11) and condenser (21) which are connected by a main line (10) for effecting the primary circulation, wherein the high-speed machine (1) comprises a turbine (3), generator (4) and possibly a main feed pump (5) installed on a joint rotor (2), and wherein the bearing (6) of the rotor (2) is arranged to be carried out by fluid lubrication and particularly in a situation of continuing operation of the process through the condenser (21) along the main line (10) of primary circulation, characterized in that in a stoppage situation of the primary circulation in the main line (10), the vaporizer (11) is connected to the high-speed machine (1) by flow organs (7, 8, 9) passing the condenser (21) and at least partly passing the main line (10) of primary circulation, to secure the fluid lubrication of the bearings (6) of the rotor (2).

2. Method according to claim 1, characterized in that
- a branch point (10a) is arranged between the high-speed machine (1) and the inlet side of the vaporizer (11) in the main line;
 - a barrier organ (15a) is arranged in connection with the branch point (10a) of the main line (10), the barrier direction of which is arranged in a way that it prevents the flow of circulating medium to the direction of the high-speed machine (1) in the main line (10);

- the inlet side of the flow organ (7, 8) providing circulating medium to the high-speed machine is connected to the branch point;
 - 5 - the outlet side of the said flow organ (7, 8) is connected to the bearings (6); and
 - the circulating medium is returned from the high-speed machine (1) to the main line (10) by means
10 of a flow organ (9) for returning the circulating medium.
3. Method according to claims 1 and 2, **characterized** in that
- 15 - a branch point (10a) is arranged between the high-speed machine (1) and the inlet side of the vaporizer (11) in the main line;
 - 20 - a barrier organ (15a) is arranged in connection of the branch point (10a) of the main line, the barrier direction of which is arranged in a way that it prevents the flow of circulating medium to the direction of the high-speed machine (1) in the
25 main line (10);
 - the inlet side of the first flow organ (7) is connected to the branch point and the outlet side of the first flow organ (7) is connected to the
30 device (12, 14) for conveying circulating medium to the high-speed machine (1); and
 - the circulating medium is conveyed by the said
35 device (12, 14) for conveying circulating medium to the high-speed machine to the bearings (6) using the second flow organ (8).

4. Method according to one of the claims 1 to 3, **characterized** in that the pressurized circulating medium accumulated in the vaporizer (11) in a liquid state is passed by the first flow organ (7) for the driving power of the fluid ejector (12) operating as a device for conveying circulating medium in a way that it pumps the lubricating fluid needed for the bearings (6) by using the second flow organ (8).
- 10 5. Method according to claim 4, **characterized** in that the inlet side of the second flow organ (8) is arranged between the pre-feed pump (13) located after the fluid ejector (12) in the direction of flowing of the circulating medium in the main line (10), which pump is part of the apparatus in the main line (10), and the said fluid ejector (12), wherein the operation of the pre-feed pump (13) is discontinued and/or the flow of the circulating medium to the pre-feed pump (13) is prevented e.g. by a reflux valve during application of the method.
- 15 20 6. Method according to one of the claims 1 to 3, **characterized** in that the pressurized circulating medium accumulated in the vaporizer (11) in a liquid state is passed by the first flow organ (7) to the pressure side of the pre-feed pump (14) operating as a device for conveying circulating medium to the main line (10).
- 25 30 7. Method according to claim 6, **characterized** in that one or more organs, such as a one-direction valve (15b) or corresponding, are arranged on one hand in the part between the main line (10) and the branch point (10b) of the second flow organ (8), and on the other hand in the part between the main line (10) and the branch point of the outlet side of the third flow organ (9) in the main line (10) against the normal flow direction of the circulating medium.
- 35

8. Method according to one of the claims 1 to 4 or 6, **characterized** in that one or more organs (17) controlling the pressure of the circulating medium, such as a pressure-reducing valve or corresponding, are arranged in the first flow organ (7).

9. Method according to one of the claims 1 to 4 or 6, **characterized** in that one or more organs (16) limiting the temperature of the circulating medium, such as a temperature-controlled valve or corresponding, is arranged in the first flow organ.

10. Method according to claim 7, **characterized** in that the inner volume of the vaporizer (11) containing circulating medium is arranged in relation to the inner volumes of flow organs (7, 8, 9) and the bearings (6) in a way that after the closing of the main operational valve (18), the stoppage of the operation of the vaporizer (11), due to the rise in pressure and/or temperature of the circulating medium accumulated in the vaporizer (11), and the stoppage of flow through the first flow organ (7) takes place essentially later than the closing of the operational valve (18), to secure lubrication of the bearings (6).

FIG 1

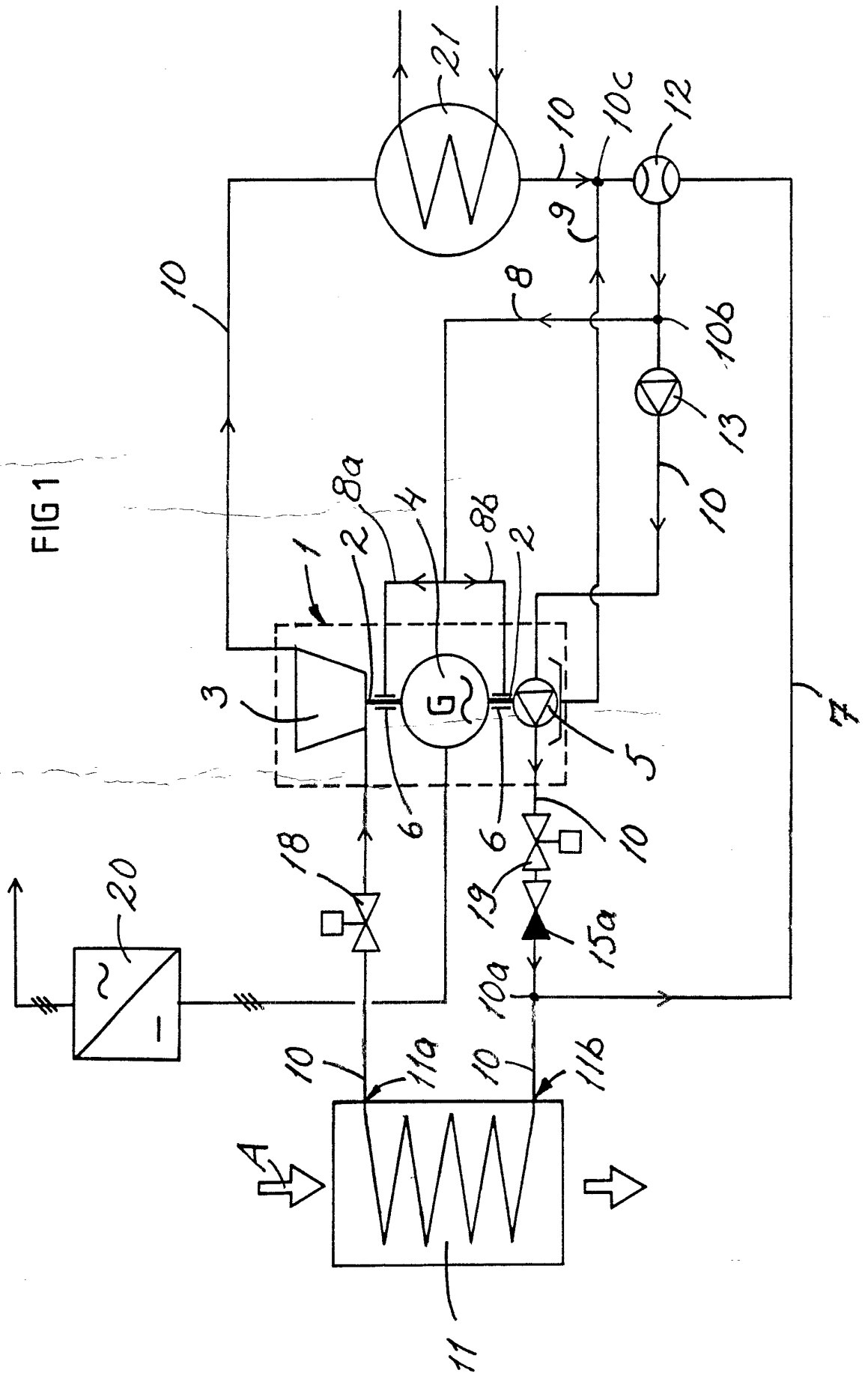
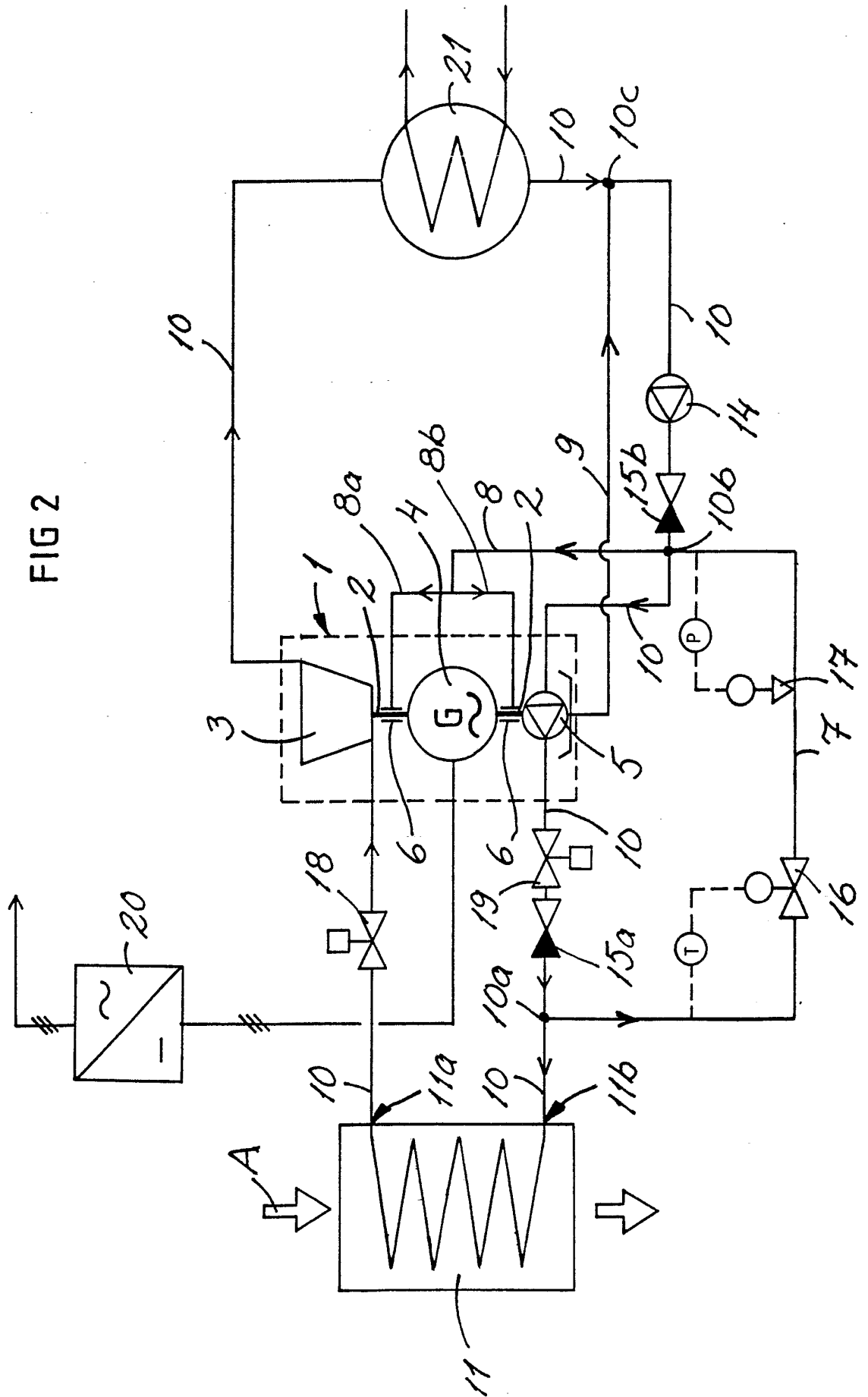





FIG 2



INTERNATIONAL SEARCH REPORT

International Application No PCT/FI 91/00295

I. CLASSIFICATION OF SUBJECT MATTER (if several classification symbols apply, indicate all) ⁶ According to International Patent Classification (IPC) or to both National Classification and IPC IPC5: F 01 D 25/22														
II. FIELDS SEARCHED <div style="text-align: center;">Minimum Documentation Searched⁷</div> <table border="1" style="width: 100%; border-collapse: collapse;"> <tr> <td style="width: 25%; padding: 5px;">Classification System</td> <td style="padding: 5px;">Classification Symbols</td> </tr> <tr> <td style="padding: 5px;">IPC5</td> <td style="padding: 5px;">F 01 D</td> </tr> </table> <div style="text-align: center;">Documentation Searched other than Minimum Documentation to the Extent that such Documents are Included in Fields Searched⁸</div>			Classification System	Classification Symbols	IPC5	F 01 D								
Classification System	Classification Symbols													
IPC5	F 01 D													
III. DOCUMENTS CONSIDERED TO BE RELEVANT⁹ <table border="1" style="width: 100%; border-collapse: collapse;"> <thead> <tr> <th style="width: 10%; padding: 5px;">Category *</th> <th style="width: 60%; padding: 5px;">Citation of Document,¹¹ with indication, where appropriate, of the relevant passages¹²</th> <th style="width: 30%; padding: 5px;">Relevant to Claim No.¹³</th> </tr> </thead> <tbody> <tr> <td style="padding: 5px;">A</td> <td style="padding: 5px;">US, A, 4363216 (BRONICKI) 14 December 1982, see the whole document ---</td> <td></td> </tr> <tr> <td style="padding: 5px;">A</td> <td style="padding: 5px;">US, A, 4044561 (HOHN) 30 August 1977, see the whole document ---</td> <td></td> </tr> <tr> <td style="padding: 5px;">A</td> <td style="padding: 5px;">US, A, 3935710 (DICKINSON) 3 February 1976, see the whole document --- -----</td> <td></td> </tr> </tbody> </table>			Category *	Citation of Document, ¹¹ with indication, where appropriate, of the relevant passages ¹²	Relevant to Claim No. ¹³	A	US, A, 4363216 (BRONICKI) 14 December 1982, see the whole document ---		A	US, A, 4044561 (HOHN) 30 August 1977, see the whole document ---		A	US, A, 3935710 (DICKINSON) 3 February 1976, see the whole document --- -----	
Category *	Citation of Document, ¹¹ with indication, where appropriate, of the relevant passages ¹²	Relevant to Claim No. ¹³												
A	US, A, 4363216 (BRONICKI) 14 December 1982, see the whole document ---													
A	US, A, 4044561 (HOHN) 30 August 1977, see the whole document ---													
A	US, A, 3935710 (DICKINSON) 3 February 1976, see the whole document --- -----													
<table style="width: 100%; border: none;"> <tr> <td style="width: 50%; vertical-align: top; border: none;"> <p>* Special categories of cited documents:¹⁰</p> <p>"A" document defining the general state of the art which is not considered to be of particular relevance</p> <p>"E" earlier document but published on or after the international filing date</p> <p>"L" document which may throw doubts on priority claim(s) or which is cited to establish the publication date of another citation or other special reason (as specified)</p> <p>"O" document referring to an oral disclosure, use, exhibition or other means</p> <p>"P" document published prior to the international filing date but later than the priority date claimed</p> </td> <td style="width: 50%; vertical-align: top; border: none;"> <p>"T" later document published after the international filing date or priority date and not in conflict with the application but cited to understand the principle or theory underlying the invention</p> <p>"X" document of particular relevance, the claimed invention cannot be considered novel or cannot be considered to involve an inventive step</p> <p>"Y" document of particular relevance, the claimed invention cannot be considered to involve an inventive step when the document is combined with one or more other such documents, such combination being obvious to a person skilled in the art.</p> <p>"&" document member of the same patent family</p> </td> </tr> </table>			<p>* Special categories of cited documents:¹⁰</p> <p>"A" document defining the general state of the art which is not considered to be of particular relevance</p> <p>"E" earlier document but published on or after the international filing date</p> <p>"L" document which may throw doubts on priority claim(s) or which is cited to establish the publication date of another citation or other special reason (as specified)</p> <p>"O" document referring to an oral disclosure, use, exhibition or other means</p> <p>"P" document published prior to the international filing date but later than the priority date claimed</p>	<p>"T" later document published after the international filing date or priority date and not in conflict with the application but cited to understand the principle or theory underlying the invention</p> <p>"X" document of particular relevance, the claimed invention cannot be considered novel or cannot be considered to involve an inventive step</p> <p>"Y" document of particular relevance, the claimed invention cannot be considered to involve an inventive step when the document is combined with one or more other such documents, such combination being obvious to a person skilled in the art.</p> <p>"&" document member of the same patent family</p>										
<p>* Special categories of cited documents:¹⁰</p> <p>"A" document defining the general state of the art which is not considered to be of particular relevance</p> <p>"E" earlier document but published on or after the international filing date</p> <p>"L" document which may throw doubts on priority claim(s) or which is cited to establish the publication date of another citation or other special reason (as specified)</p> <p>"O" document referring to an oral disclosure, use, exhibition or other means</p> <p>"P" document published prior to the international filing date but later than the priority date claimed</p>	<p>"T" later document published after the international filing date or priority date and not in conflict with the application but cited to understand the principle or theory underlying the invention</p> <p>"X" document of particular relevance, the claimed invention cannot be considered novel or cannot be considered to involve an inventive step</p> <p>"Y" document of particular relevance, the claimed invention cannot be considered to involve an inventive step when the document is combined with one or more other such documents, such combination being obvious to a person skilled in the art.</p> <p>"&" document member of the same patent family</p>													
IV. CERTIFICATION <table border="1" style="width: 100%; border-collapse: collapse;"> <tr> <td style="width: 50%; padding: 5px;">Date of the Actual Completion of the International Search</td> <td style="width: 50%; padding: 5px;">Date of Mailing of this International Search Report</td> </tr> <tr> <td style="padding: 5px;">4th December 1991</td> <td style="padding: 5px;">1991 -12- 18</td> </tr> <tr> <td style="padding: 5px;">International Searching Authority</td> <td style="padding: 5px;">Signature of Authorized Officer</td> </tr> <tr> <td style="padding: 5px; text-align: center;">SWEDISH PATENT OFFICE</td> <td style="padding: 5px; text-align: center;">  P-O Warnbo </td> </tr> </table>			Date of the Actual Completion of the International Search	Date of Mailing of this International Search Report	4th December 1991	1991 -12- 18	International Searching Authority	Signature of Authorized Officer	SWEDISH PATENT OFFICE	 P-O Warnbo				
Date of the Actual Completion of the International Search	Date of Mailing of this International Search Report													
4th December 1991	1991 -12- 18													
International Searching Authority	Signature of Authorized Officer													
SWEDISH PATENT OFFICE	 P-O Warnbo													

**ANNEX TO THE INTERNATIONAL SEARCH REPORT
ON INTERNATIONAL PATENT APPLICATION NO.PCT/FI 91/00295**

This annex lists the patent family members relating to the patent documents cited in the above-mentioned international search report. The members are as contained in the Swedish Patent Office EDP file on 31/10/91. The Swedish Patent Office is in no way liable for these particulars which are merely given for the purpose of information.

Patent document cited in search report	Publication date	Patent family member(s)	Publication date
US-A- 4363216	82-12-14	AU-D- 7638481	82-04-29
		EP-A-B- 0050959	82-05-05
		JP-C- 1567782	90-07-10
		JP-A- 57105509	82-07-01
US-A- 4044561	77-08-30	CH-A- 574564	76-04-15
		DE-A- 2443204	76-03-04
US-A- 3935710	76-02-03	JP-C- 973276	79-09-28
		JP-A- 51034303	76-03-24
		JP-B- 54004442	79-03-07