

(No Model.)

M. N. HUTCHINSON.
PASSENGER OR OTHER ELEVATOR.

No. 299,548.

Patented June 3, 1884.

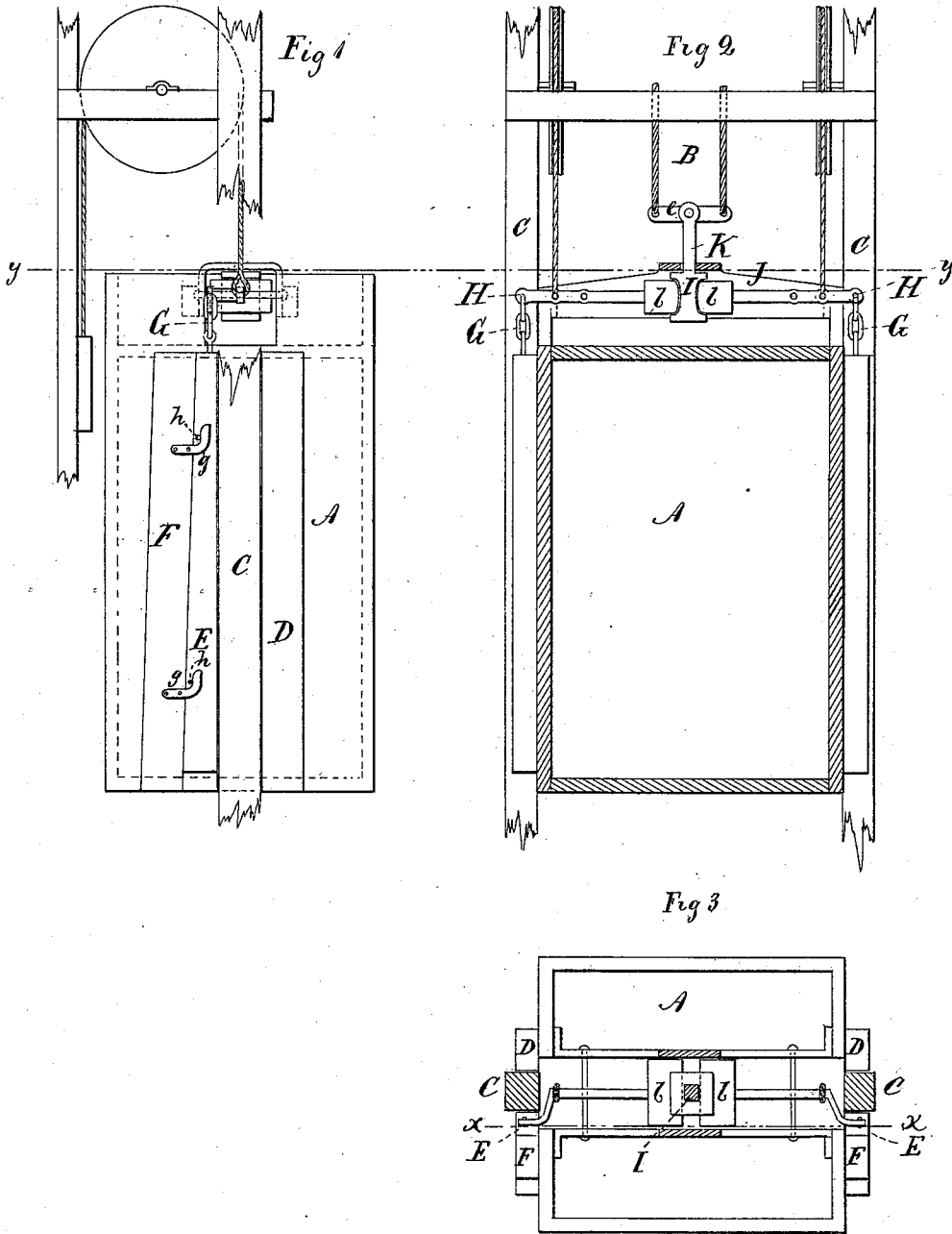

WITNESSES:

Rudolf M. ...
John H. Fisher

INVENTOR

Merrill N. Hutchinson
BY *James M. Whitney*
ATTORNEY

UNITED STATES PATENT OFFICE.

MERRILL N. HUTCHINSON, OF NEW YORK, N. Y.

PASSENGER OR OTHER ELEVATOR.

SPECIFICATION forming part of Letters Patent No. 299,548, dated June 3, 1884.

Application filed December 27, 1883. (No model.)

To all whom it may concern:

Be it known that I, MERRILL N. HUTCHINSON, of the city, county, and State of New York, have invented an Improvement in Passenger and other Elevators, of which the following is a specification.

This invention relates to that class of devices employed to stop or retard the downward movement of a passenger or other elevator in the event of the breaking of the draft or hoisting rope or ropes; and its object is to provide a safety apparatus of the class mentioned which is extremely simple and strong in construction, capable of being instantaneously set in operation in the event of casualty of the character just indicated, and very effective in stopping the downward movement of the car in such event; and this, too, without inordinate jar or concussion.

The invention comprises a novel combination of parts, peculiarly arranged in effective relation with each other, whereby the objects specified are effectually secured.

Figure 1 is a side view of an apparatus made according to my invention. Fig. 2 is a vertical transverse sectional view of the same, taken in the line *x x* of Fig. 3; and Fig. 3 is a horizontal sectional view taken in the line *y y* of Figs. 1 and 2.

A is the usual car or cage of the elevator, provided in any suitable manner with the usual draft or hoisting rope or ropes, which are represented in the drawings by the reference-letter B.

Placed at opposite sides of the car or cage A, and close to the same, are vertical posts C. These posts should be firmly secured in position, and, although preferably placed at the central portion of the opposite sides of the car or cage, as shown in Figs. 1 and 2, may, when desired, be arranged at or near the opposite corner of the same.

Upon each side of the car or cage, either framed in one therewith to make part of the structure itself, or bolted or otherwise secured thereto, is a vertical shoulder, D, which is arranged close to the nearest flat side of the adjacent post C, either lightly in contact therewith, or so near to said post that a very slight lateral movement of the car or cage will bring said shoulder in contact with said surface of

said post. This shoulder is preferably flat and continuous on its side next the post; but it may, when preferred, comprise any form or contour or surfaces, or any arrangement of bearing-surfaces in vertical line with each other, to bear against the post in the same relation thereto as when the bearing-surface of said shoulder is straight and continuous, as aforesaid.

Upon each side of the car, at the side of the post opposite that occupied by the shoulder D, is a guide, F, somewhat inclined from the vertical, as shown in Fig. 1. These guides may be formed of bars firmly bolted or otherwise secured to the car or cage, or they may be framed in one with the structure of said car or cage.

Placed between each guide F and the adjacent post C is a wedge, E, the inner side of which is designed to act upon the adjacent surface of said post when the wedge is pushed upward with reference to the car or cage, in which case the inclined portion of the guide F causes the wedge to move inward in contact with the post, and, slightly swaying the car or cage, causes the opposing shoulders D to come in contact with the side adjacent thereto of said post, the post being thereby gripped between the wedge and the shoulder with a constantly-tightening hold. Each wedge E is connected, by a link, rod, or chain, G, or other equivalent device, with the outer end of a lever, H, which is pivoted, as shown at *a*, to the top of the car or cage. The inner ends of these levers may be provided, as represented in the drawings, with heads *b*, which fit into sockets in the sides of a suspension-block, I. The inner arms of said levers are preferably connected with a counter-weight by means of a rope or chain passing over a suitable pulley, and which, in the event of the parting of the draft or hoisting rope, serves to at once lift said outer arms of said levers; or, in lieu of these, said arms of said levers may be fitted with springs arranged to press them downward. When preferred, the inner levers may be suitably loaded to depress their inner ends for the same purpose. From the block extends upward (through an opening in the bar J, fixed to the top of the car) a shank, K, to which, by a cross-bar, *e*, are attached the draft

or hoisting ropes. The block I bearing against the under side of the bar J enables the draft or hoisting ropes to actuate the car; but in the event of the breaking of the latter, the inner arms of the levers, being thrown downward with reference to the car or cage, lift the wedges with reference to the said car or cage, and cause the posts to be gripped between the wedges and the shoulders with a force and tenacity proportioned to the weight of the car or cage, inasmuch as the frictional contact of the wedges with the posts tends of itself to lift the wedges with reference to the car or cage. Instead of the springs and levers to throw upward the wedges when the strain of the draft or hoisting rope is released, any other equivalent appliances may be employed to actuate the wedges in an upward direction for the purposes aforesaid.

In order that the wedges may not bend against the posts when the car or cage is suspended from the draft-ropes, inclined lugs or

ears *g'* are attached to the outer sides of the guides F and project over the outer surfaces of the wedges. Stud or pins *h* project from the latter behind said lugs or ears, so that when the wedges descend, the pins being moved outwardly by the inclined rear surfaces of the lugs, the wedges are thrown back out of contact with the posts.

What I claim as my invention is—

The combination, with the posts and car or cage A, of the shoulders D, fixed on said car or cage, and arranged to grip in immediate contact with said posts, the inclined guides F upon the car or cage, and the wedges placed between said guides and posts, the whole arranged substantially as and for the purpose herein set forth.

MERRILL N. HUTCHINSON.

Witnesses:

JOHN H. FISHER,
RUDOLF H. NIGELLMAN.