

H. K. Jones,
Gage Lathe.

N^o 48,409.

Patented June 27, 1865.

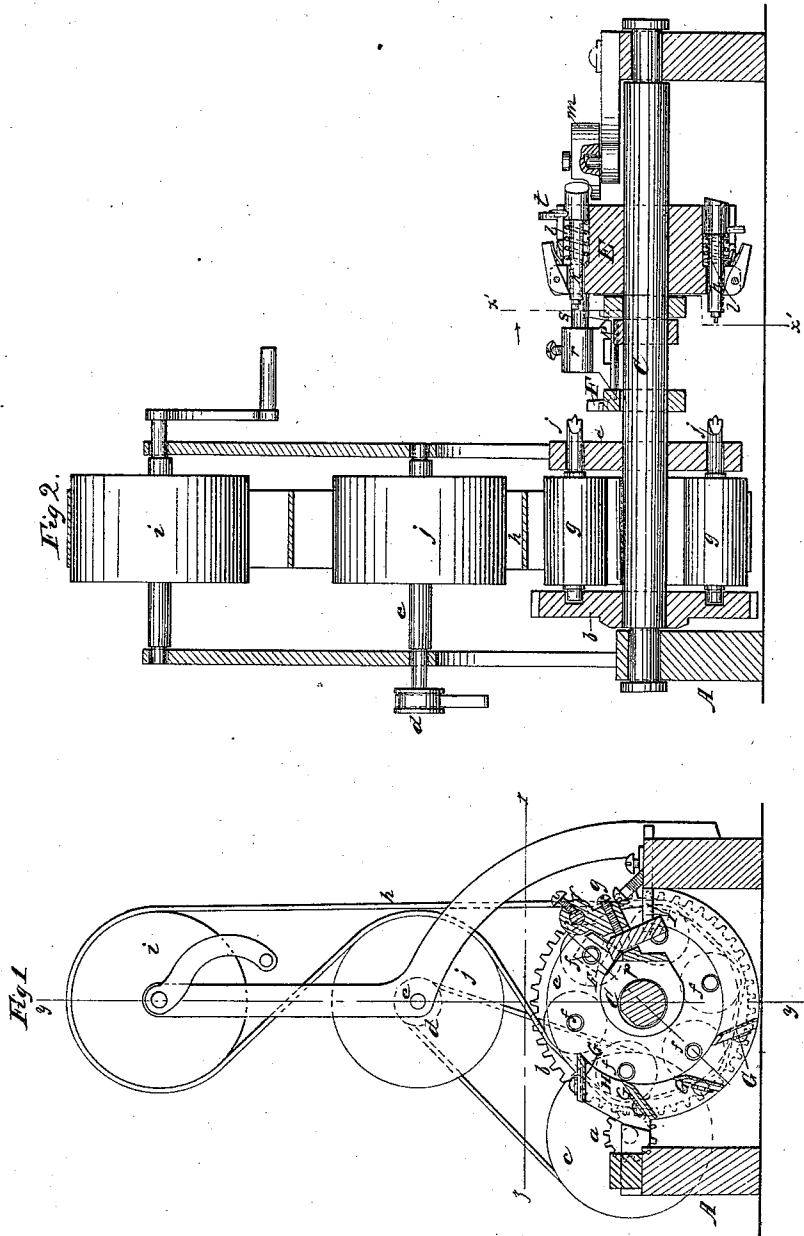

Witnesses:
C. D. Smith
A. C. Alameda

Inventor:
H. K. Jones
By J. H. Moore
Attorney

H. K. Jones, Gage Lathe.

N^o 48,409.

Patented June 27, 1865.

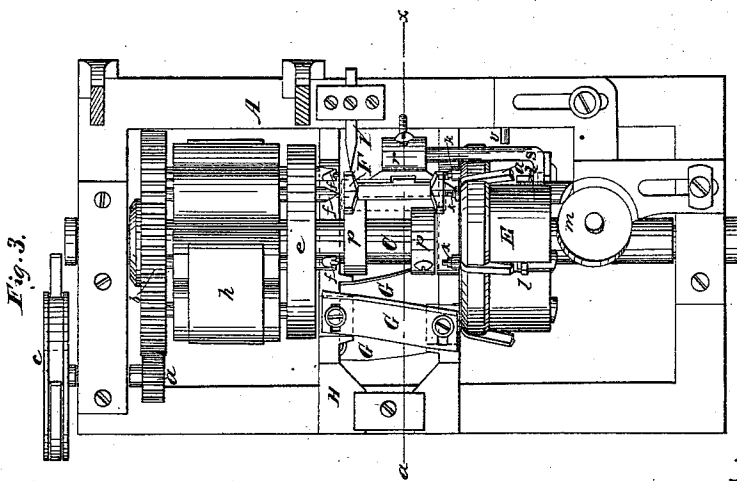
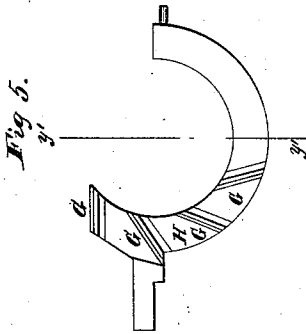
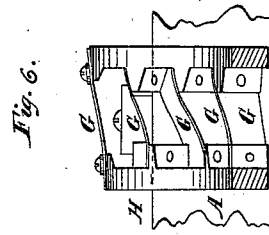
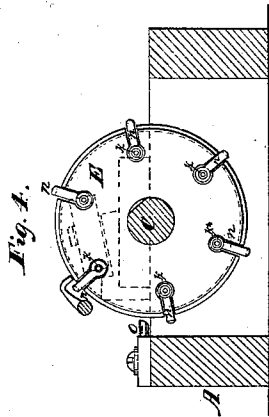

Witnesses:
W. D. Brown
Geo. Tusch.

Inventor:
H. K. Jones
per Wm. D. B.
Attorney

UNITED STATES PATENT OFFICE.

H. K. JONES, OF KENSINGTON, CONNECTICUT.

IMPROVEMENT IN LATHES FOR TURNING TOOL-HANDLES.

Specification forming part of Letters Patent No. 48,409, dated June 27, 1865.

To all whom it may concern:

Be it known that I, H. K. JONES, of Kensington, in the county of Hartford and State of Connecticut, have invented a new and Improved Machine for Turning Tool - Handles; and I do hereby declare that the following is a full, clear, and exact description thereof, which will enable others skilled in the art to make and use the same, reference being had to the accompanying drawings, forming part of this specification, in which—

Figure 1 is a transverse vertical section of this invention, the line $x x$, Fig. 2, indicating the plane of section. Fig. 2 is a longitudinal vertical section of the same, the plane of section being indicated by the line $y y$, Fig. 1. Fig. 3 is a horizontal section of the same, taken in the plane indicated by the line $z z$, Fig. 1. Fig. 4 is a transverse vertical section, the line $x' x'$, Fig. 2, indicating the plane of section. Fig. 5 is a detached elevation of the cutter-frame. Fig. 6 is a transverse vertical section of the same, the line $y' y'$, Fig. 5, indicating the plane of section.

Similar letters of reference indicate like parts.

This invention relates to a machine in which the blocks are placed in a V-shaped trough, from which they are taken up automatically, one after the other, by two sets of centers. One set of centers form the shafts of drums or pulleys, to which a revolving motion is imparted by a belt or by a friction-wheel, or by both combined, and the other set of centers is arranged in a revolving head, and to each center a longitudinal sliding motion is imparted at the proper intervals by a cam in a forward direction, and backward by a spring in such a manner that the spurs on the revolving centers are driven into the blocks and the latter compelled to revolve with said centers and afterward released. The trough containing the blocks is adjustable, so that its position can be regulated to suit the thickness of the blocks, and it follows the revolving heads which carry the centers for a short distance until the block is firmly held between said centers in the desired position. The cutters are all stationary, the shaping-cutters being secured in a segmental frame and the cutting-off tool in a recess cut for that purpose in the frame. The shaping-cutters are removable, so that they can be

easily taken off and replaced by others, or that they can be sharpened and readjusted without difficulty, and the frame containing a full set of cutters can also be removed.

A represents a frame, which is made of wood or any other suitable material. The end pieces of this frame form the bearings for the main shaft C, to which a slow and powerful rotary motion is imparted by gear-wheels $a b$ and pulleys $c d$, one of which is secured to the end of the driving-shaft e , as clearly shown in Figs. 1 and 2. The cog-wheel b is firmly keyed to the shaft C, and at a certain distance from said cog-wheel is the disk e , mounted on the main shaft. The cog-wheel and disk form the bearings for a series of spindles f , to which the pulleys g are firmly secured, and these spindles are placed at equal distances from the main shaft. Their inner ends extend through the disk e , and are provided with spurs (with or without a center spur) to catch hold of the blocks and cause them to revolve with the spindles, to which rotary motion is imparted either by a belt, h , extending from a drum, i , on the line-shaft, over a drum, j , on the driving-shaft of the machine, and around the pulleys g on the spindles f , which might be oiled, if desirable, or by a friction-wheel filling the space inclosed by the drums or pulleys, and bearing equally upon all.

The sliding centers k are fitted into a head, E, which is firmly held by a set-screw at such a distance from the disk e that the blocks from which the tool-handles to be turned can be readily placed between the centers.

It is obvious that the centers k must be in line with the spindles f , and they are adjusted to the action of springs l , (see Fig. 2,) and have a tendency to throw the same back in the direction of the arrows marked on said centers in Fig. 2.

A cam, m , which bears on the rear ends of the centers k as the same revolve with the drum E, presses the same forward against the action of the springs and spring-dogs n , catching in the ratchet-teeth cut in the surface of the centers to retain the same in the desired position. When the handle between two of the centers is finished the tail of the spring-dog comes in contact with a stationary pin, o , Fig. 3, and thereby the sliding center is released and allowed to follow the action of the spring l , and

the finished handle drops down, making room for a fresh block.

The blocks to be turned are placed, one after another, into a V-shaped trough, F, which is supported by arms *p* radiating from and swinging on the main shaft C. Said trough is adjusted in the desired position by a set-screw, *q*, and the arms turn up and combine to form a head, *r*, in which is secured a hook, *s*, which extends over the drum E, as clearly shown in Fig. 3. Pins *t*, which project through slots in the circumference of the drum, catch under said hook as the drum revolves and carry the trough F along, so that the block which has been placed on said trough is kept in the proper position between the centers, to which the same is to be secured. When the sliding center *k* strikes the cam or roller *m* and begins to move forward, driving the block into the spur-center, the pin *t* disengages the hook *s* and the trough drops back to its original position, ready to receive a new block. After the block has been thus secured between the centers, it is carried along by the revolving motion of the main shaft C, and at the same time an independent rotary motion is imparted to the block by the action of the belt *h* on the pulleys *g*, so that when brought in contact with the cutters G it will gradually be brought in the desired shape. Said cutters are stationary, and secured to a segmental frame, H, which is fastened to the frame A between the disk *e* and drum E. A series of cutters are used, and these cutters are so shaped that the first cutter will take off the corners of the block, the second will begin to turn the same round, and so on, little by little, until the final shape is given to the wood by the last cutter. Each cutter is adjustable toward and from the work, so that a larger or smaller cut can be taken, and the full set of cutters can also be taken out and replaced by others of different form and shape

to correspond to various articles to be turned. After the handle or other article has been turned to the proper shape it is brought in contact with the cutting-off tool I, which is also stationary and secured to the frame A, as shown in Figs. 1 and 3.

This tool cuts off the end of the wood near the spur-center, and the finished handle, being released by the retreating action of the sliding center *k*, drops down into a suitable box or receptacle.

A very large number of tool-handles or other similar articles can thus be turned and finished in a superior manner in a short time with little labor or attention.

I claim as new and desire to secure by Letters Patent—

1. The spindles *f*, provided with spurs, and arranged in a revolving head, *b e*, and operating, in combination with the longitudinally-sliding centers *k*, in the revolving drum E, substantially as and for the purpose set forth.
2. Giving to the spur-centers a sun-and-planet motion by means substantially such as herein described, for the purpose set forth.
3. Giving to the centers *k* an automatic reciprocating motion by means of a spring and cam, or other equivalent means, substantially as and for the purpose specified.
4. The pins *t* and hook *s*, applied, in combination with the trough F and centers *k*, substantially in the manner and for the purpose described.
5. The use of stationary cutters G I, in combination with centers *f k*, arranged in revolving heads, substantially as and for the purpose set forth.

H. K. JONES.

Witnesses:

E. B. HOTCHKISS,
JNO. W. CLARK.